

No. 189

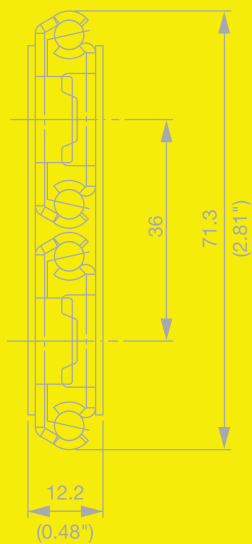
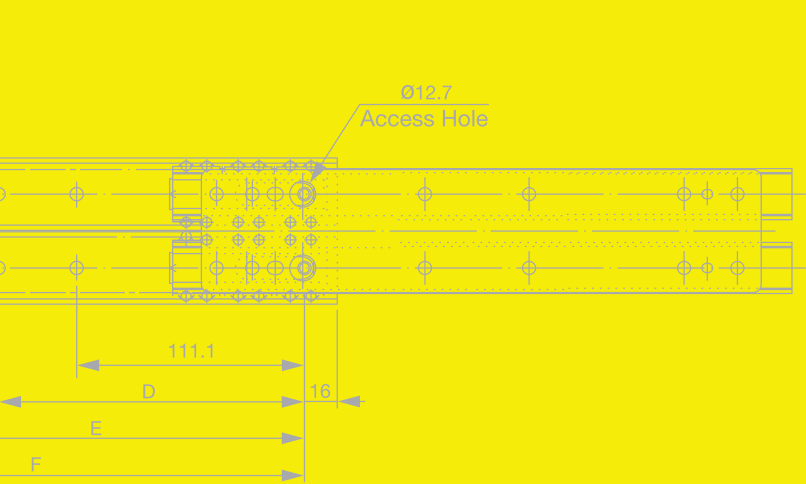
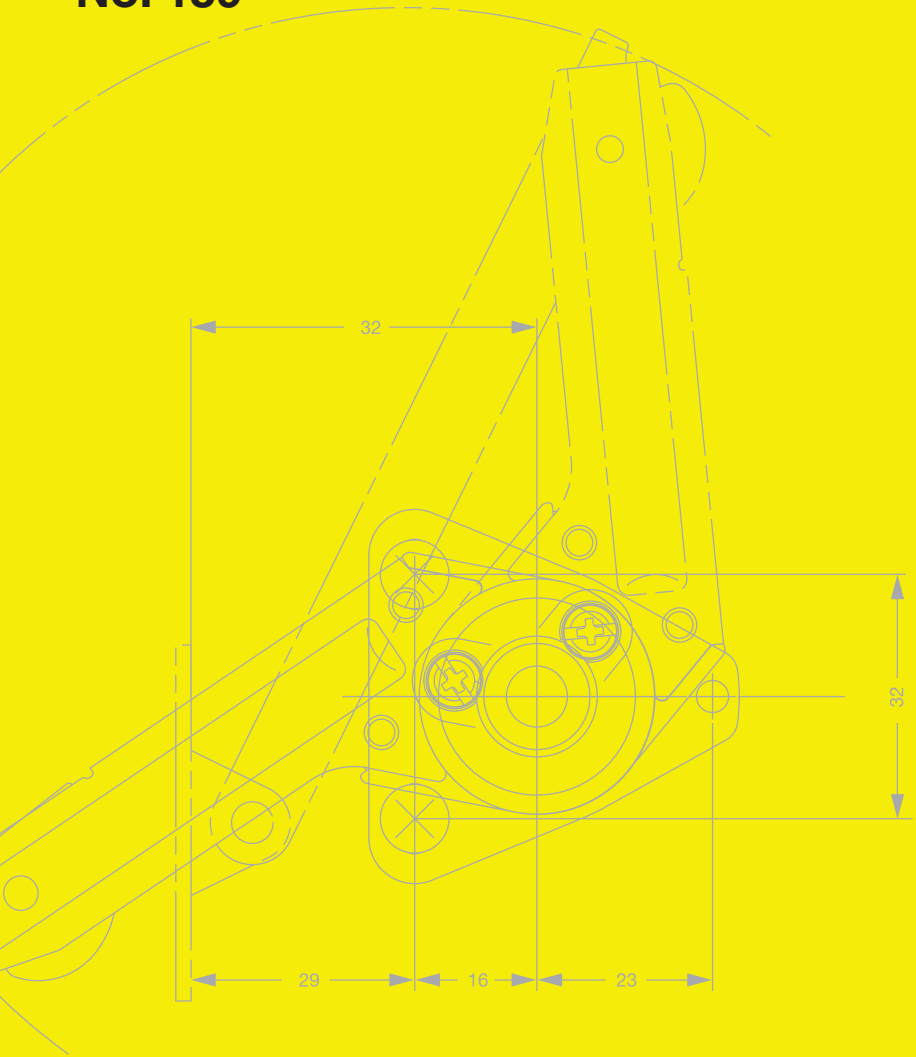

# SUGATSUNE

Industrial Component Hardware

Sugatsune - A hardware manufacturer with worldwide reputation for high quality products that combines ingenious design with meticulous attention to detail.

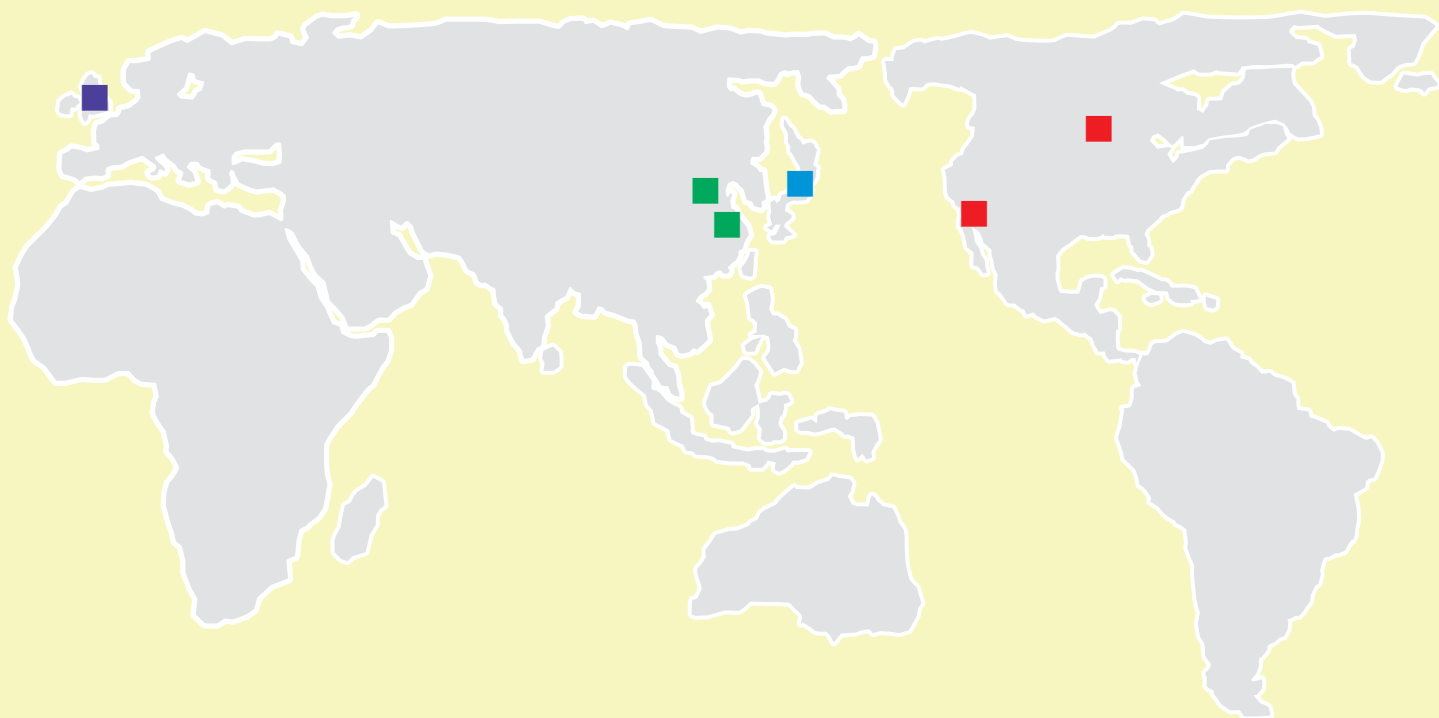

■ UK Office



■ TOKYO Showroom

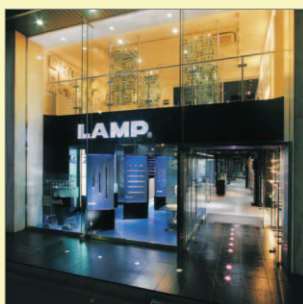

■ Global Headquarters



■ Chicago Office



■ Beijing Office



■ Shanghai Office



■ Los Angeles Office



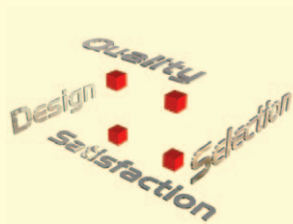

**LAMP**  
by SUGATSUNE

**Motion**  
DesignTec



**Lapcon**

## SOLUTIONS FROM AN INDUSTRY LEADER

SUGATSUNE continues to be a leading source for unique, high-quality hardware products. Architects, builders, designers and OEM's continue to depend on our SUGATSUNE quality and craftsmanship. You'll see and feel the **Lapcon** difference in every product, from catches and latches to our patented dampening mechanisms.

Manufacturing the finest quality hardware is our mission. With design offices in Japan and distributorships in the U.S.A. , U.K., China, and around the world, we offer prompt delivery to meet your deadlines and schedules.

## THE SUGATSUNE DIFFERENCE

### **Precision Quality** - Guaranteed

Our products are designed to meet your exacting standards. SUGATSUNE quality craftsmanship ensures years of trouble-free operation.

### **Vast Selection** - Guaranteed

Choose from more than 20,000 items, all manufactured by SUGATSUNE or produced exclusively for us. Each product is created to meet your every need in the global marketplace with extensive local distribution and large inventory.

### **Customer Satisfaction** - Guaranteed

You can rely on the SUGATSUNE combination of product and availability to insure complete satisfaction. Experience our superior customer service from the moment you place your order to the time an order ships.

### **Advanced Design** - Guaranteed

SUGATSUNE is constantly innovating advanced new hardware solutions. Our design and engineering staff stay abreast of the latest trends to bring you exemplary products.

ISO 9001



ISO 9001:2000  
JSAQ384



JAB  
QS Accreditation  
R001

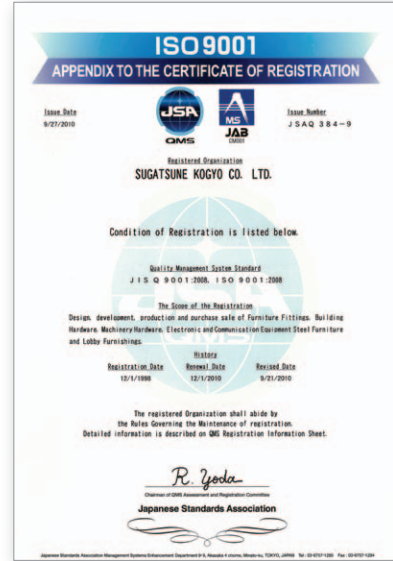

\* Registered for Global Headquarter Sugatsune Kogyo Co.,Ltd.

ISO 14001



ISO 14001:1996  
JSAE597



JAB  
EMS Accreditation  
RE005

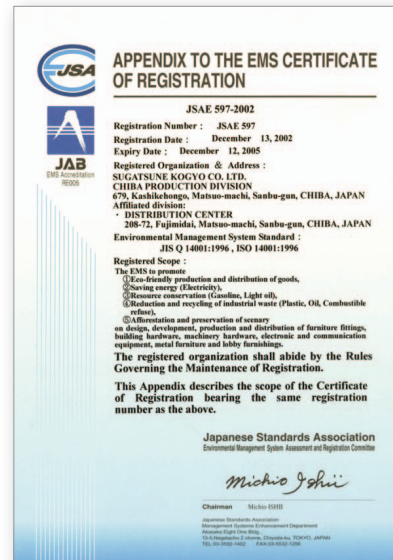

\* Registered for Global Headquarter Sugatsune Kogyo Co.,Ltd.

NSF



NSF International  
**RECOGNIZES SUGATSUNE AMERICA, INC.  
CARSON, CA**

AS COMPLYING WITH NSF C2.  
PRODUCTS APPEARING IN THE NSF OFFICIAL LISTING ARE  
AUTHORIZED TO BEAR THE NSF MARK.

SUGATSUNE's NSF Certified Products are designed to meet Food Equipment Industry Standard.  
SUGATSUNE's NSF Certified part numbers are subject to change without notice.  
When placing an order please specify NSF products.

RoHS



SUGATSUNE has started changing products to comply with the European RoHS directive. Hexavalent Chromium is changed to either chromium free or trivalent chromium. Most of the stainless steel products do not contain Hexavalent Chromium. Please contact sales for RoHS compliant product information.

SEMI



SUGATSUNE's SEMI compliant products are designed to meet SEMI S8, a safety guideline for ergonomics engineering of semiconductor manufacturing equipment.

This catalog is specifically designed to provide to you complete technical information & drawings.

**Header Pages**    **Description**    **Material**    **Features of items**    **Header**

**Categories**

**SPRING LOADED BARREL BOLT**    **BS-SL**

**SPRING LOADED BAR LATCH**    **BL**

**GATE LATCH**    **SSG**

**BAR LATCH**    **BLT**

**Please use Item Code and Item Name when ordering**    **Installation**    **Drawings**

## Features

**Lapcon**  
Patented products as Lapcon

**NUT**  
Stainless Nut

**NO SCREW**  
No Screw

**STAINLESS 304**  
304 Stainless Steel

**RoHS**  
ROHS certified products

**NUT**  
Steel Nut

**NEODYMIUM**  
Strong Magnet

**STAINLESS 316**  
316 Stainless Steel

**NSF**  
NSF certified products

**SCREW**  
Stainless Screw with Size

**STAINLESS 430**  
430 Stainless Steel

**ALUMINUM**

**SEMI**  
Products Compliant with Semi Guideline (SEMI S8)

**SCREW**  
Steel Screw with Size

**STAINLESS 303**  
303 Stainless Steel

**TITANIUM**

**TEST METHOD**

**LOAD CAPACITY**  
0-00 kgf

- All items, unless specified, are made to exact metric dimension.
- Changes in dimensions, finishes, packing, etc., and suspension of production may occur without notice.
- Our liability is limited to the replacement of the merchandise.

## Aluminum Frame Support System

ALUMINUM FRAME SUPPORT SYSTEM

Page 17-25

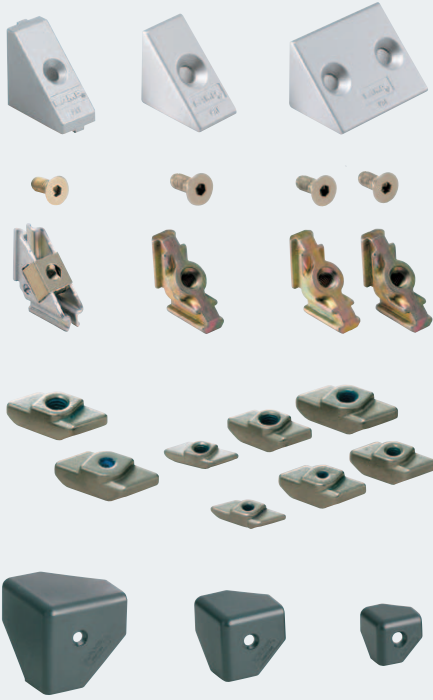

## Titanium Hardware

TITANIUM HARDWARE

Page 27-30



## Magnetic Catches

ULTRA THIN & STRONG MAGNETIC CATCHES  
HIGH TEMPERATURE MAGNETIC CATCHES  
SNAP-IN MAGNETIC CATCHES  
RUBBER MAGNETIC CATCHES

Page 31-54



## Hooks & Brackets

SWING HOOKS  
RECESSED HOOKS  
FOLDING BRACKETS  
SHELF ORGANIZERS

Page 213-249

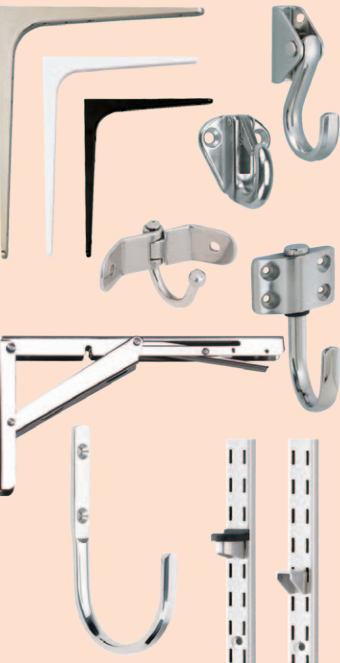

## Torque Dampers

DISK DAMPER  
TORQUE DAMPER

Page 251-259

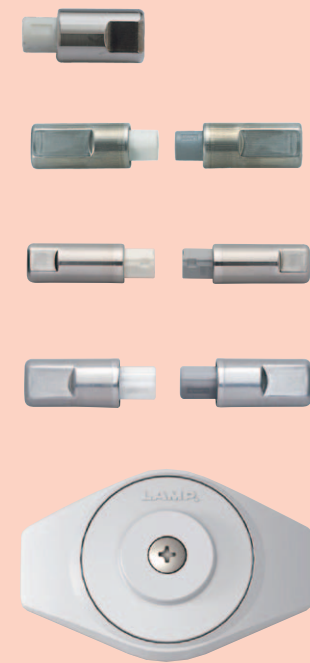

## Hinges

BUTT HINGES  
LIFT-OFF HINGES  
PIANO HINGES  
LIFT ASSIST & SOFT-CLOSE HINGES  
CONCEALED HINGES

Page 261-333

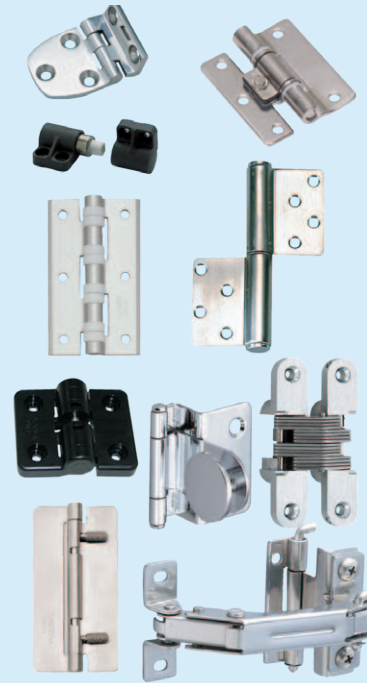

## Handles, Pulls & Knobs

RECESSED PULLS  
TRUNK HANDLES  
HATCH PULLS  
SPECIALITY HANDLES

Page 335-387



## Catches & Latches

ROTARY/ROLLER CATCHES  
LEVER LATCHES  
SLIDE / BARREL BOLTS  
PUSH LOCK FASTENERS

Page 55-104



## Lid Supports

SOFT CLOSE / LIFT ASSIST STAYS  
SPRING LOADED LIFT ASSIST STAYS  
TORQUE LID STAYS

Page 105-155



## Drawer Slides

FULL EXTENSION SLIDES  
3/4 EXTENSION SLIDES  
LINEAR SLIDES  
SOFT CLOSING/PUSH OPEN SLIDES  
ALUMINUM

Page 157-212



## Casters

LOW PROFILE HEAVY DUTY CASTERS  
SHOCK ABSORBING CASTERS  
BALL CASTERS  
BASE

Page 389-423



## Leveling Glides

LEVELING GLIDES

Page 425-437



## Locks

CAM LOCKS  
PUSH LOCKS  
CABINET LOCKS

Page 439-450



## Miscellaneous

CABLE GROMMET  
VENTILATORS  
LED LIGHTS  
BELT REEL PARTITION

Page 451-466



# Transportation



FT  
P. 347



BSS  
P. 73



ESR-10  
P. 162



CBL-RA7R  
P. 198



HG-YJ-50  
P. 298

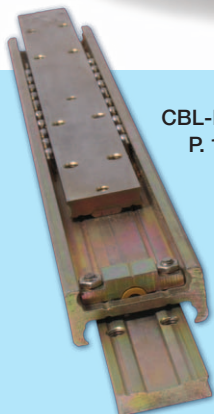

CBL-E1902  
P. 197



DS  
P. 355



LJ-61  
P. 96





MP  
P. 340



900  
P. 442



PN-51  
P. 89



NF-60  
P. 233



SFTH  
P. 321



JF  
P. 217



SCC-60  
P. 83

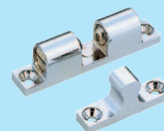

BCTS  
P. 62



MG  
P. 344

# Appliances



ESR-3813  
P. 165



AR-3  
P. 188

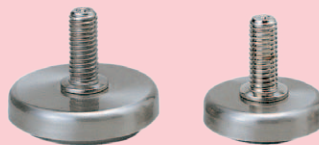

MKRS  
P. 434



HG-PV-60AC  
P. 295



Special stainless 27mm slides in 3/4 and full extension can withstand oven self-clean cycles. (P. 170 and 177)

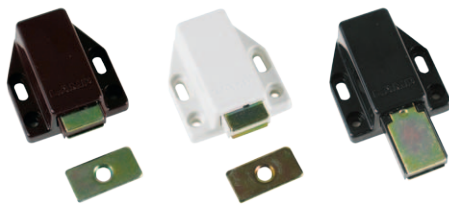

ML-80  
P. 52

GH-34/8/S  
P. 303





ESN-195  
P. 65

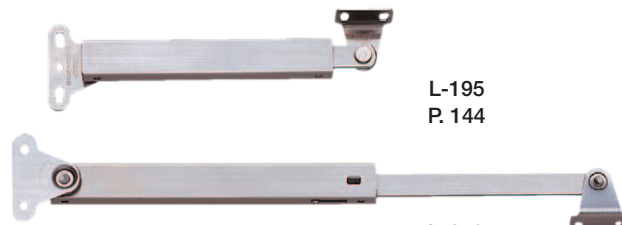

L-195  
P. 144

L-270  
P. 144



ESR-4513  
P. 164



MC-JM-45  
P. 34

MC-JM-50  
P. 34

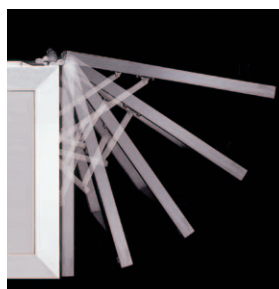

NSD-35  
P. 123



# Medical



PR4PK  
P. 65

GH-34/0/S  
P. 303



GX-W50GN  
P. 412



MX-125P  
P. 396



HG-CSH-63  
P. 299

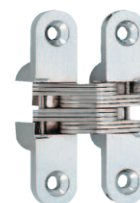

R-60  
P. 316

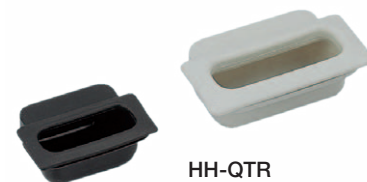

HH-QTR  
P. 370



MC-YN-001P  
P. 35

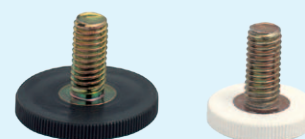

TG  
P. 436



MC-37F  
P. 66



HG-IT  
P. 321



HG-SH-C  
P. 297

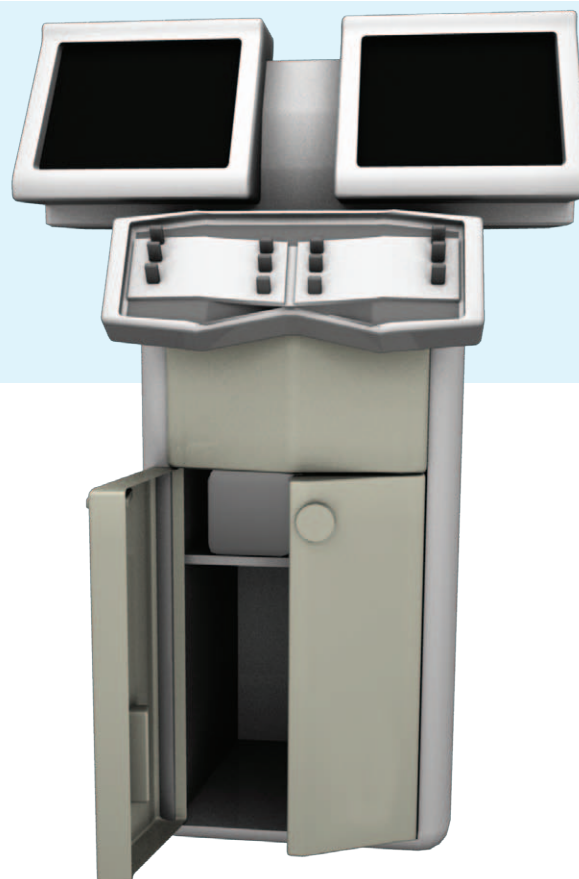

UJ  
P. 230



AR-2  
P. 189

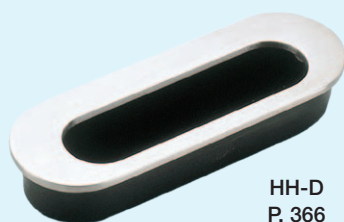

HH-D  
P. 366

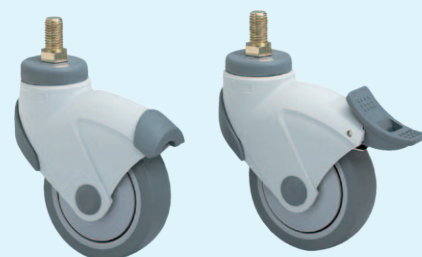

EX-100N  
P. 397

# Special Hinge Application

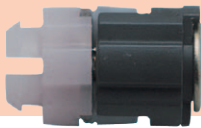

MPH-22G  
P. 327



UDH  
P. 255



UDH  
P. 255



UDH-16  
P. 257



# Semiconductor

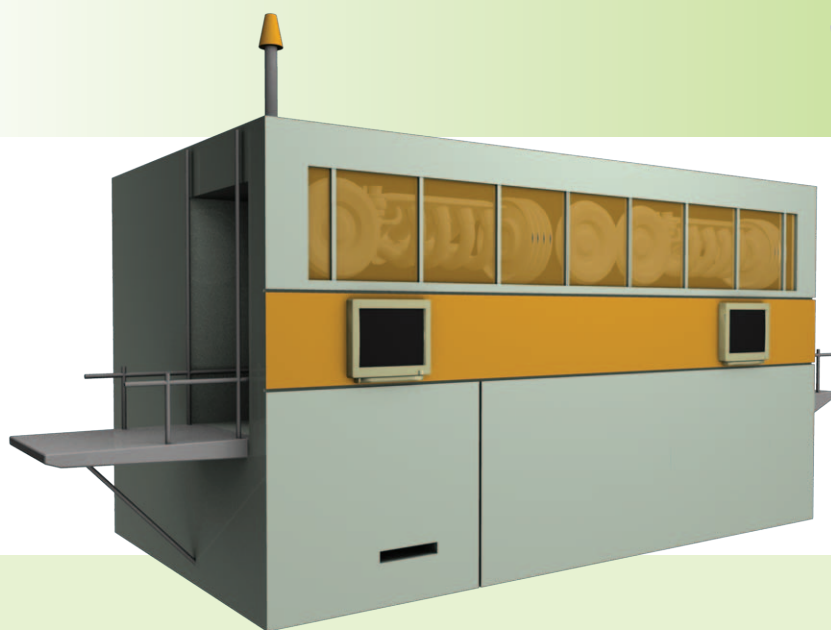

MC-JM-45  
P. 34



MC-JM-50  
P. 34



HH-KL160  
P. 366



HH-KP150  
P. 366



SNS35D  
P. 169



HG-CV-100  
P. 281

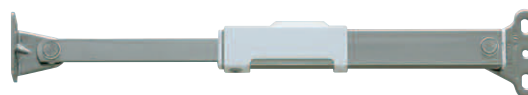

LB-CV215A  
P. 147

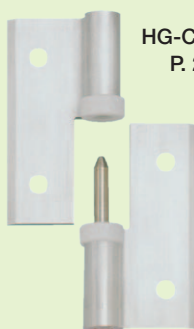

HG-CV-65N  
P. 281



# Other Industries



STF-82L  
P. 78

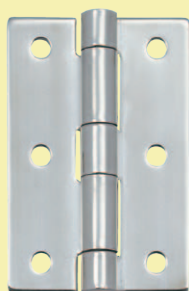

LSA  
P. 267



MRS30, MR-50C  
P. 192



XL-GH03-48-0  
P. 301



1100GL  
P. 448



MKRL  
P. 432



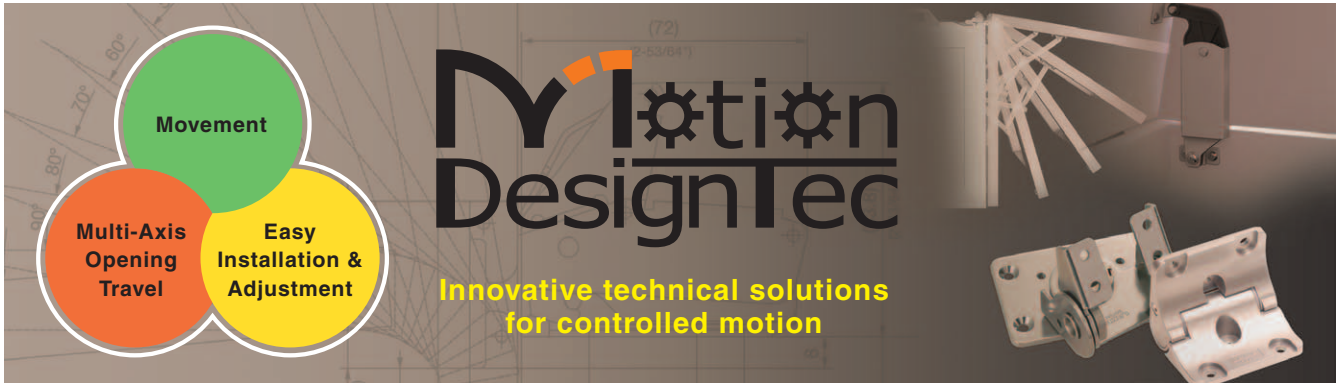

## Multi Axis & Opening Travel

Safety   Compact   Design

The concealed hinges uses multiple pivot points that allow for a wider swing and a greater degree of opening. When the door is closed the hinge is completely concealed, allowing for a clean look.

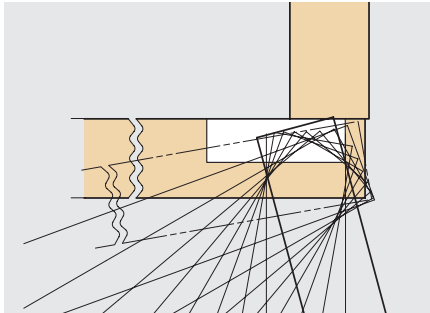

### 100 Series

Overlay doors opens without interfering with side cabinet doors. 3 way adjustability.

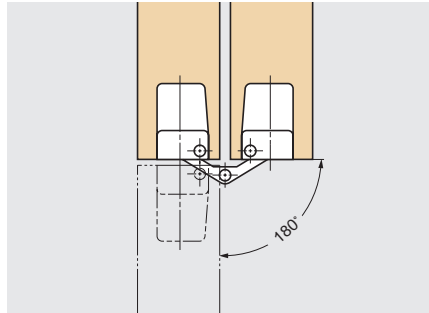

### R & HES3D series

Inset application with 180 degree opening.

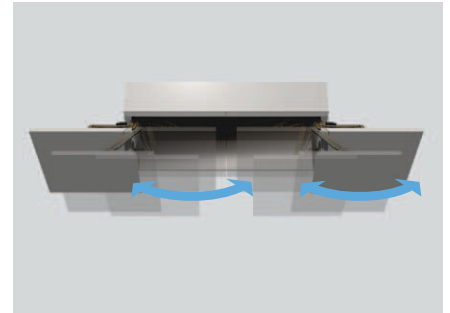

### LIN-X series

Allows doors to swing out in a small radius laterally, ideal for tight front applications.

## Easy Installation & Adjustment

Safety   Compact

Save time and labor costs with easy installation and adjustability of the HES3D hinges.

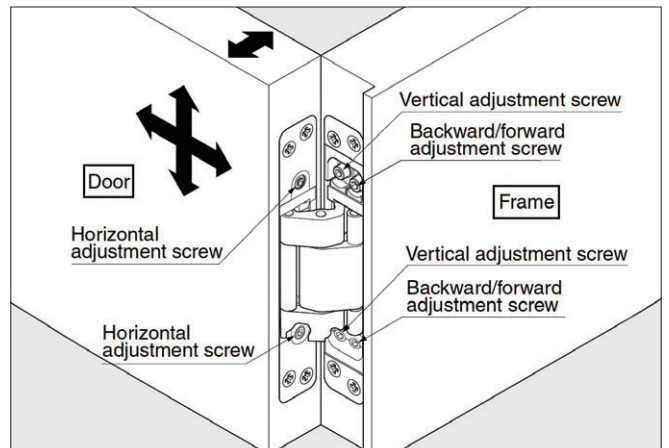
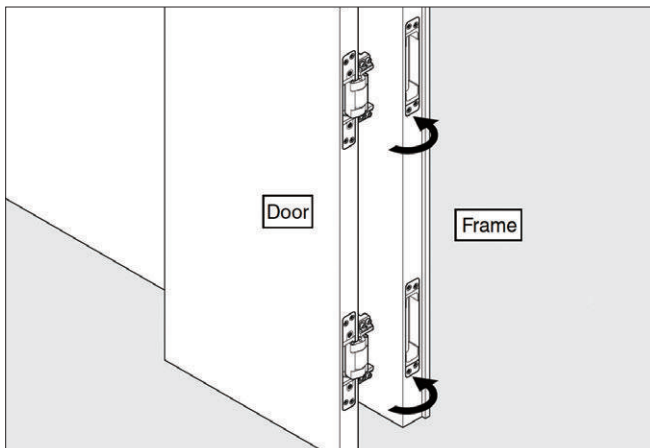

# Movement

Movement

Multi-Axis Opening Travel

Easy Installation & Adjustment

## Free Stop Motion

Safety Compact

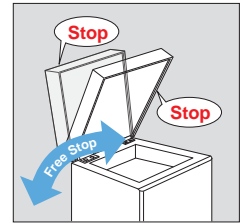
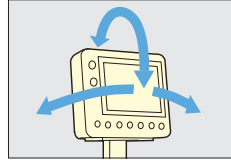

### HG-T70S30

- Dual Axis: free stop at any angle in tilt & swivel.
- Provides torque stability in both directions.
- Suitable for monitor screens.

### HG-TS

- Hinge with friction torque holds lid/door in desired position.
- Stainless steel material ideal for harsh environments.
- Best durability on continuous open/close cycle.
- Free stop between 0 - 180 degree.

Without using a stay, door can be held at any position. It can also be used to position monitors, lighting equipment, etc.

## Soft Close Motion

Safety Compact

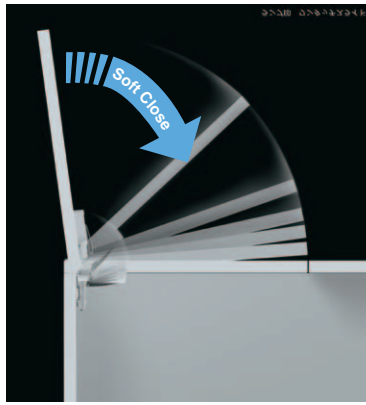
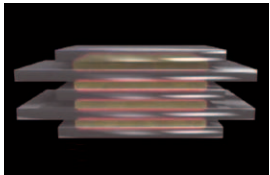
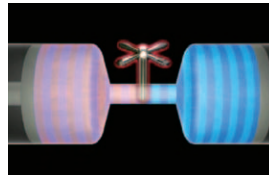

### Orifice Damper

Resistance is created when fluid passes from a larger diameter cylinder to a smaller cylinder.

### Rotary Damper

Resistance created by a damper using rotating discs filled with viscous fluid.

Opening and closing speed can be adjusted, creating a soft and quiet movement.

## Click Motion

Safety Compact



### HG-YJ50

Hold doors at 4 different positions. (90 degree increment) without secondary support.

### Click Hinge

Micro hinge for small devices such as a flip phone. The hinges catch function enables the phone to hold open at 160 degree which will produce a click sound.

A system embedded in a hinge to hold opening position at a preset angle. A click sound at preset angle to notify user of detent.

## Lift Assist Motion

Safety Soft Compact

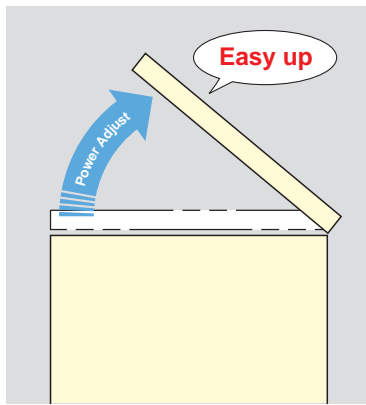

### S-AT Spring Stay

Built-in spring will provide a strong lift assist and will hold lids in place.

### HG-JH210 Lift Assist Hinge

Spring loaded hinge with a strong lift assist. Has a built-in damper that provides soft closing.

Assists in the opening of flaps and lids. Doors will feel lighter, while providing free stop and soft close.



\*M4 threaded hole  
(one side only)

## ALUMINUM FRAME SUPPORT SYSTEM

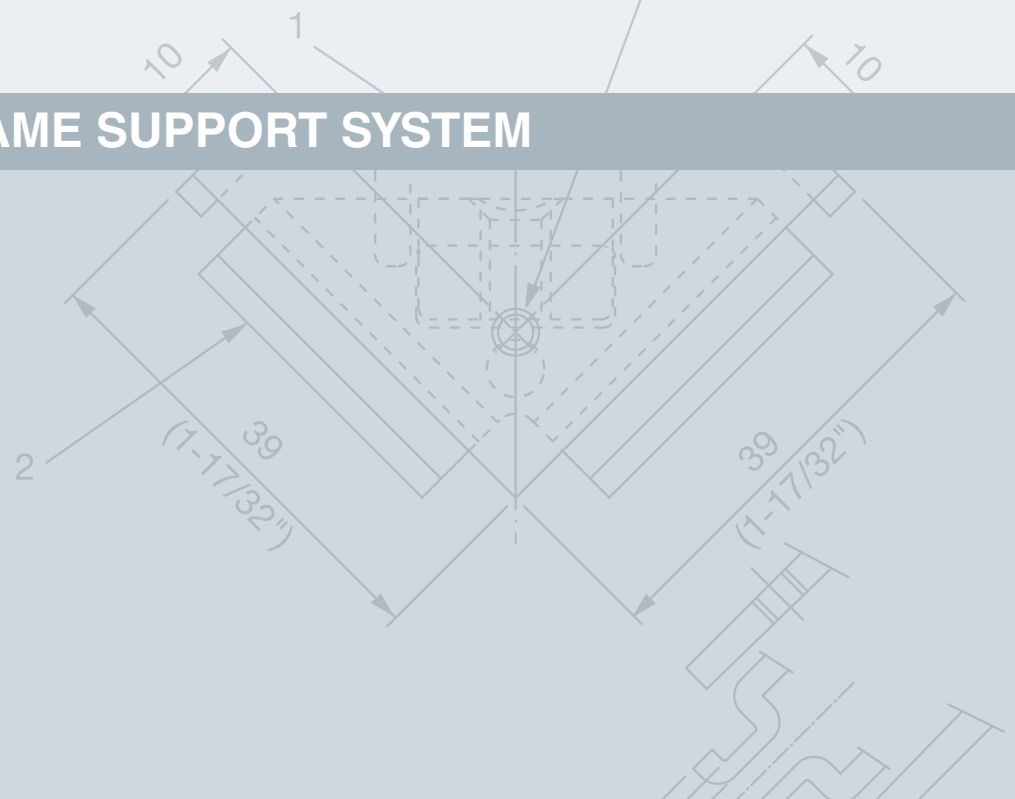

Easy assembling & installation with PJ Connector & AS Nut.

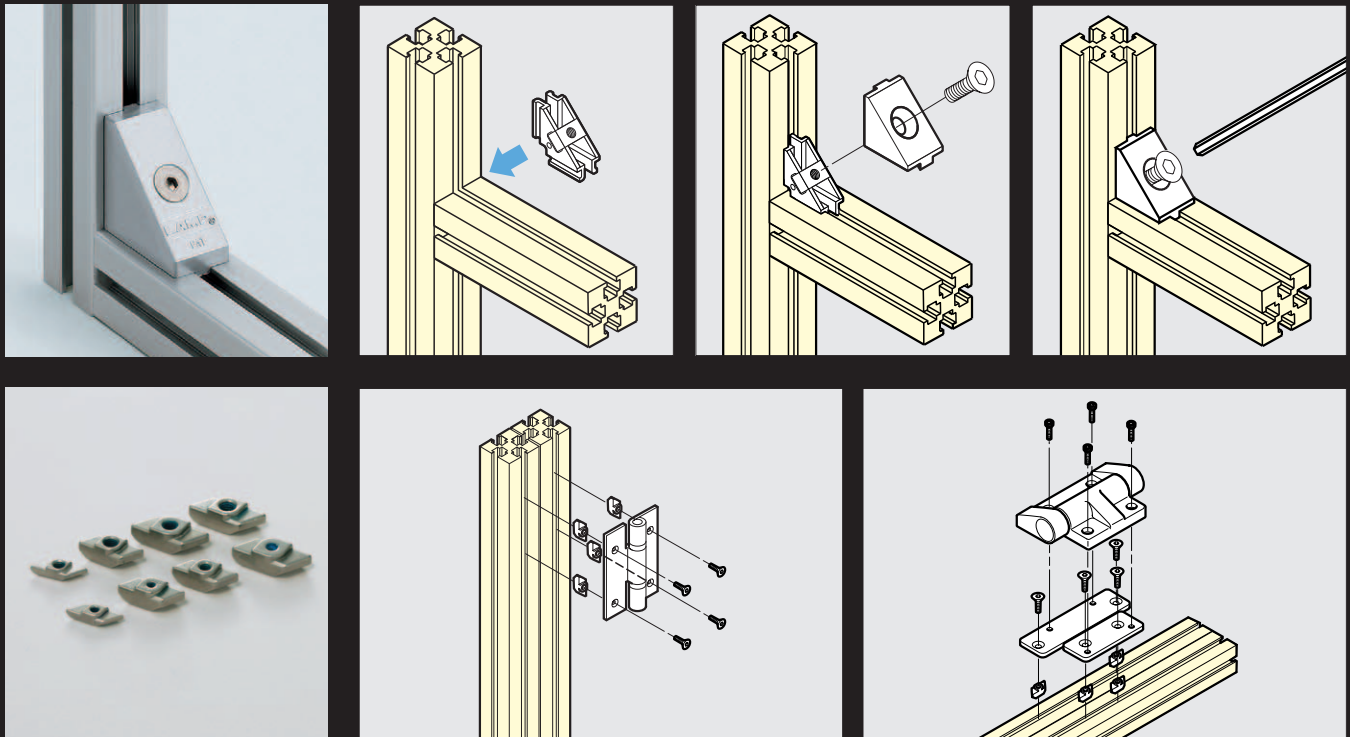

Supports different types of aluminum profiles

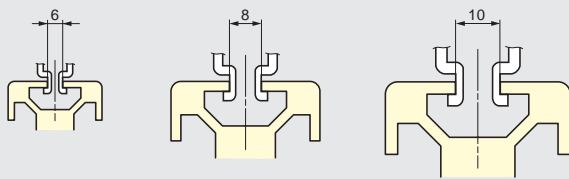
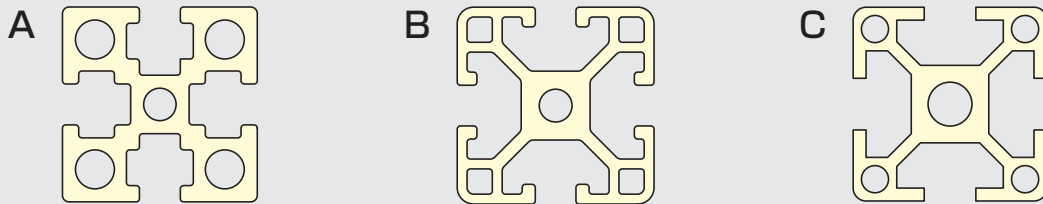

Groove : 6mm

Groove : 8mm

Groove : 10mm

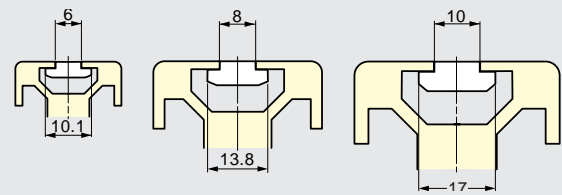

Groove : 6mm

Groove : 8mm

Groove : 10mm



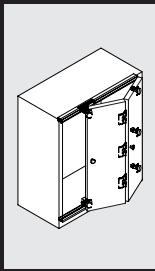
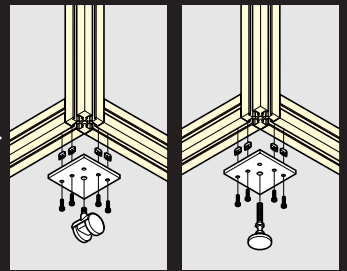
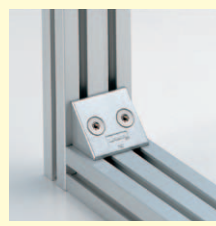
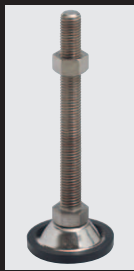
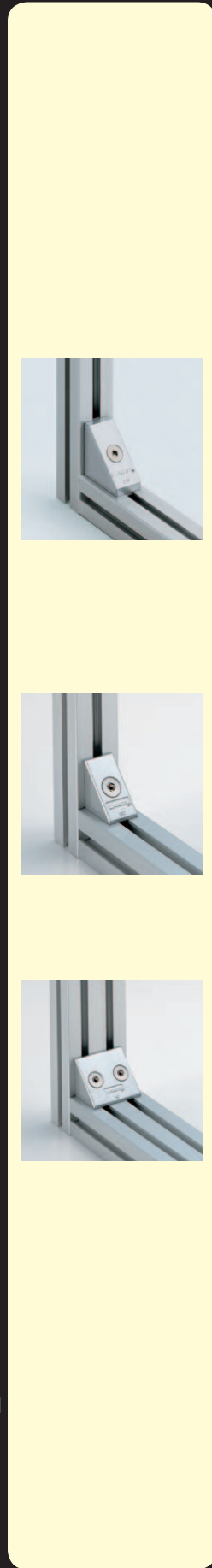
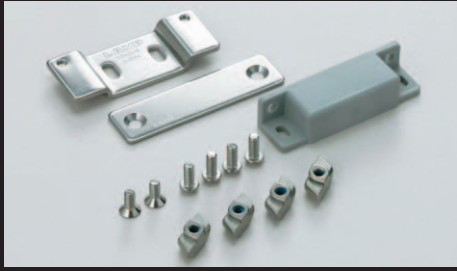

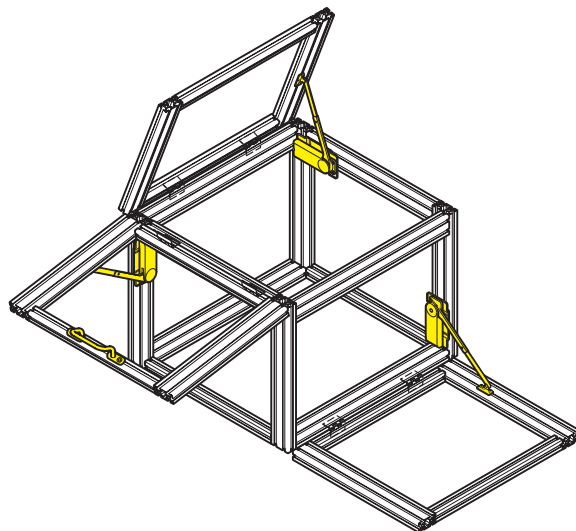
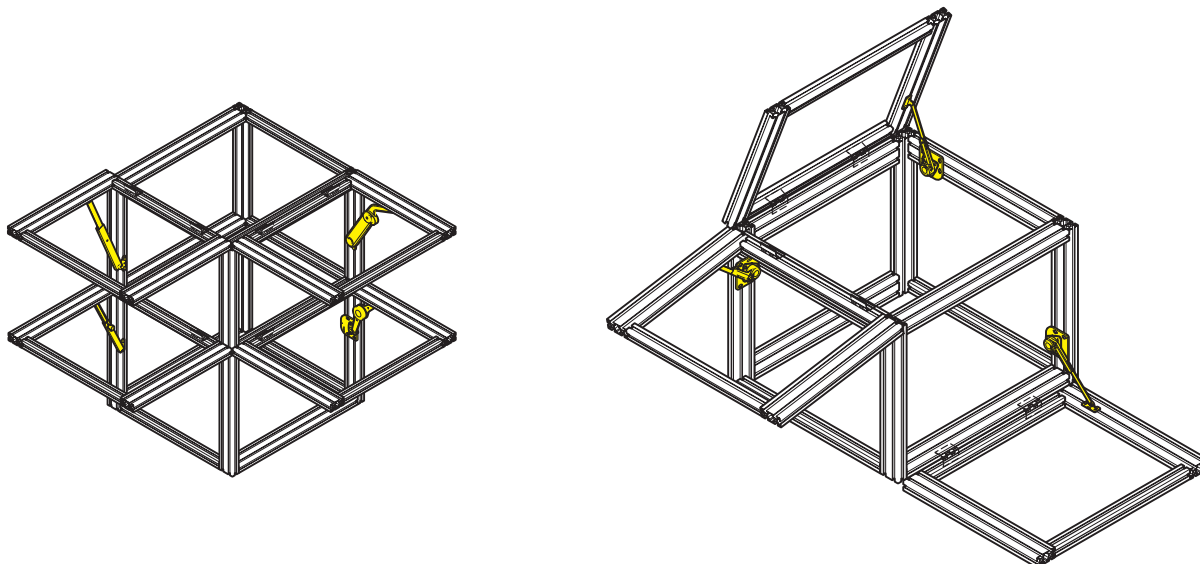
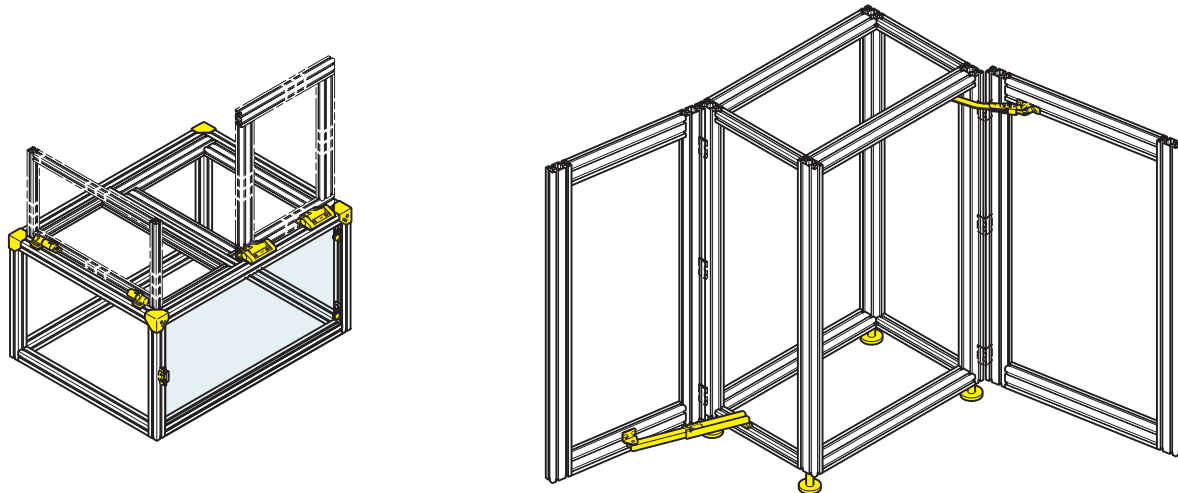

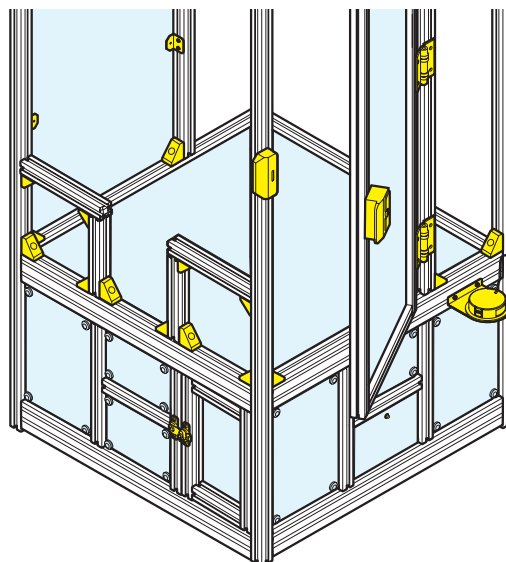
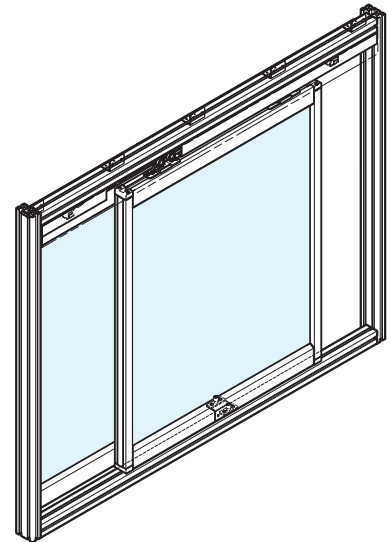
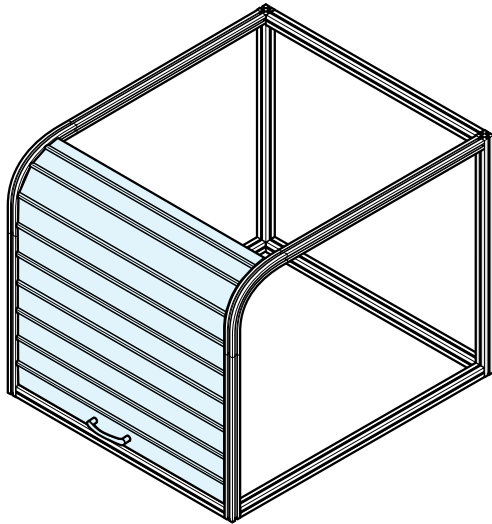
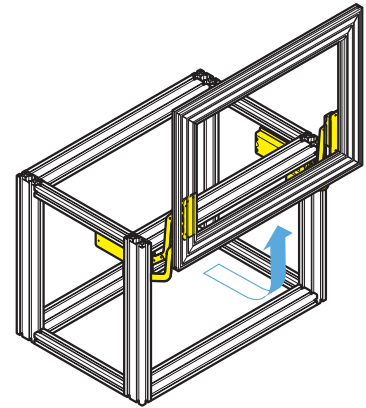
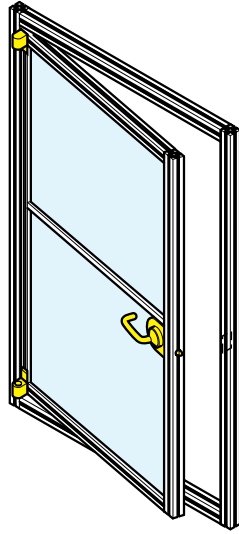

DROP-IN TYPE CORNER CONNECTOR



PJ-60A, 80A, 100HA

Electric conductive type



- Unique drop-in design saves frame assembly time.
- Automatic self-aligning, just tighten screw to connect frames.
- Ideal for assemblies where slide-in method is not practical.
- M4 threaded hole provided on AT type for panel installation.
- PJ-60A is designed for 6mm single slot frames.
- PJ-80A is designed for 8mm single slot frames.

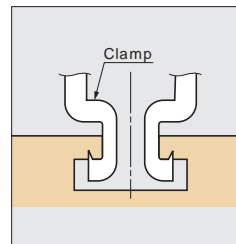
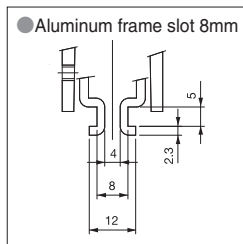
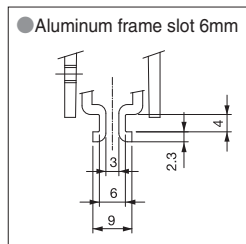
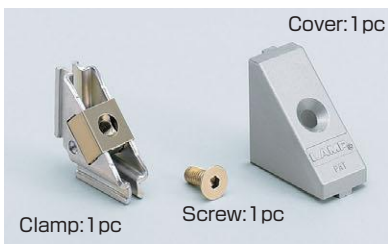

Installation

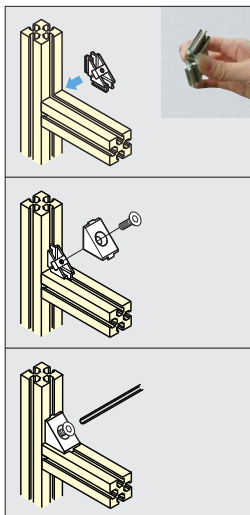

Simply insert PJ fastener into the slot.

Tighten flat head screw with allen key.

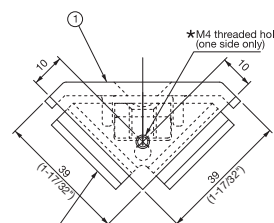
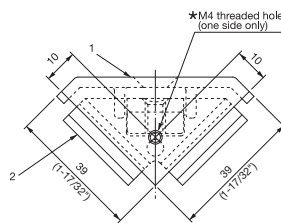
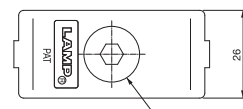
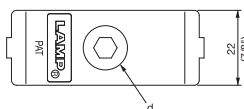

PJ-60AT (For 6mm slot frame)

PJ-80AT (For 8mm slot frame)

No.	Part Name	Material	Finish
①	Cover	Aluminum Alloy	Silver
②	Clamp	Steel	Yellow Zinc Chromate

Electric conductive type

Item Code	Item Name	M	Aluminum frame slot	A	B	C	D	E	F	d	Recommended fastening torque		Fracture load	
120-012-423	PJ-60AE	Without	6mm	55	22	10	1~3	39	B/2	M6×16	6N·m	61.2kgf·cm	284N	29kgf
120-012-424	PJ-60ATE	M4	6mm	55	22	10	1~3	39	B/2	M6×16	6N·m	61.2kgf·cm	284N	29kgf
120-012-425	PJ-80AE	Without	8mm	55	26	10	1.5~4.5	39	B/2	M8×16	13N·m	133kgf·cm	392N	40kgf
120-012-426	PJ-80ATE	M4	8mm	55	26	10	1.5~4.5	39	B/2	M8×16	13N·m	133kgf·cm	392N	40kgf

Standard type

Item Code	Item Name	M	Aluminum frame slot	A	B	C	D	E	F	d	Recommended fastening torque		Breaking load	
120-041-251	PJ-60A	Without	6mm	55	22	10	1~3	39	B/2	M6×16	6N·m	61.2kgf·cm	284N	29kgf
120-041-250	PJ-60AT	M4	6mm	55	22	10	1~3	39	B/2	M6×16	6N·m	61.2kgf·cm	284N	29kgf
120-041-253	PJ-80A	Without	8mm	55	26	10	1.5~4.5	39	B/2	M8×16	13N·m	133kgf·cm	392N	40kgf
120-041-252	PJ-80AT	M4	8mm	55	26	10	1.5~4.5	39	B/2	M8×16	13N·m	133kgf·cm	392N	40kgf
120-040-557	PJ-80HA	M5	8mm	57	25	12	1.5~4.7	40	15	M6×18	6N·m	61.2kgf·cm	392N	40kgf
120-040-558	PJ-100HA	M5	10mm	71	32.5	12	4.5~7	50	15	M8×25	13N·m	133kgf·cm	833N	85kgf



# SLIDE-IN TYPE CORNER CONNECTOR



## PJ-60, 80, 100



- Unique drop-in design saves frame assembly time.
- Automatic self-aligning, just tighten screw to connect frames.
- Ideal for assemblies where slide-in method is not practical.
- M4 threaded hole provided on AT type for panel installation.
- PJ-60A is designed for 6mm single slot frames.
- PJ-80A is designed for 8mm single slot frames.

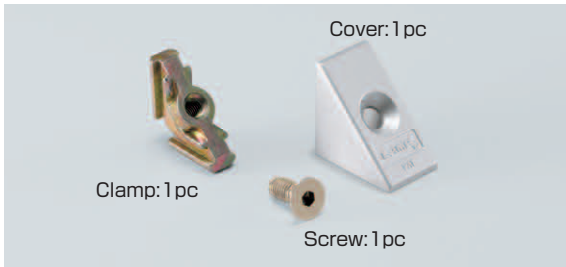

No.	Part Name	Material	Finish
①	Cover	Aluminum Alloy	Silver
②	Clamp	Steel	Yellow Zinc Chromate

### Installation

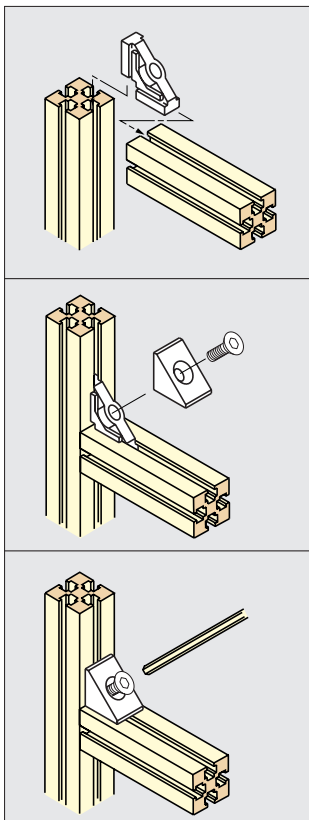

Simply insert PJ fastener into the slot.

Tighten flat head screw with allen key.

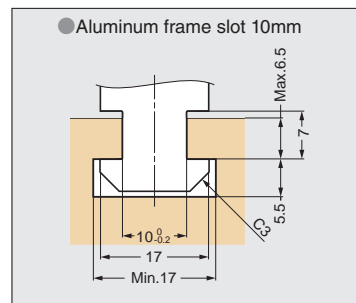
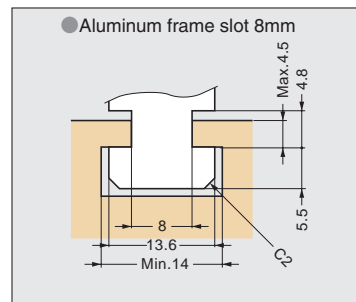
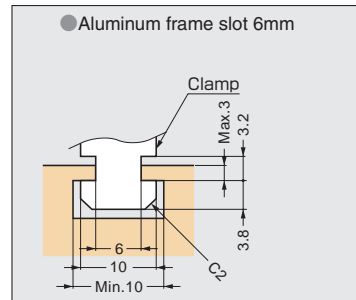

Item Code	Item Name	d <sub>1</sub>	Aluminum frame slot	A	B	C	D	d <sub>2</sub>	Recommended fastening torque
120-040-456	PJ-60	Without	6mm	41	20	29	1~3	M6×15	6N · m 61.2kgf · cm
120-040-554	PJ-60T	M4	6mm	41	20	29	1~3	M6×15	6N · m 61.2kgf · cm
120-040-490	PJ-80	Without	8mm	55	25	39	1.5~4.5	M8×20	13N · m 133kgf · cm
120-040-555	PJ-80T	M4	8mm	55	25	39	1.5~4.5	M8×20	13N · m 133kgf · cm
120-040-551	PJ-100	Without	10mm	70	30	49	3.5~6.5	M10×25	26N · m 265kgf · cm
120-040-550	PJ-100T	M4	10mm	70	30	49	3.5~6.5	M10×25	26N · m 265kgf · cm

# SLIDE-IN TYPE CORNER CONNECTOR



## PJ-60W, 80W

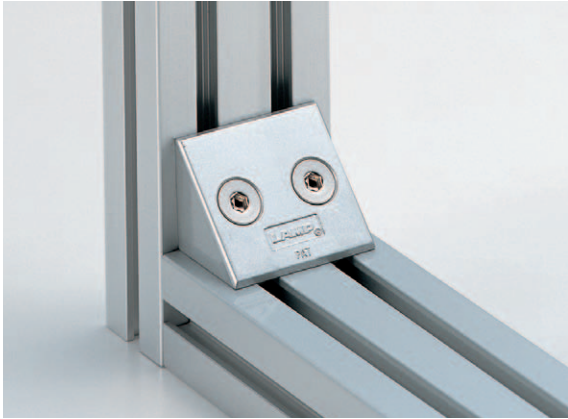

- Tighten only one screw (two for PJ-60W) to connect frames. Integral clamps eliminate need to align separate nuts and bolts.
- Simplified slide-in design saves frame assembly time.
- PJ-60W is designed for 30mm pitch, 6mm double slotted frames.
- PJ-100 is designed for 10mm single slot frames.
- M4 threaded hole provided on PJ-100T for panel installation.

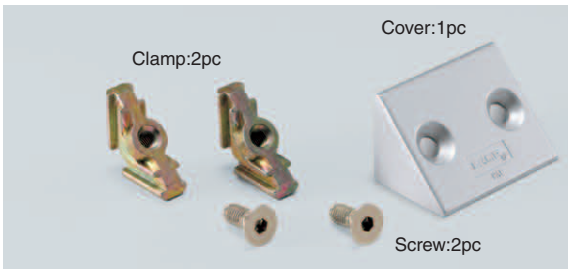

No.	Part Name	Material	Finish
①	Cover	Aluminum Alloy	Silver
②	Clamp	Zinc Alloy	Yellow Zinc Chromate

### Installation

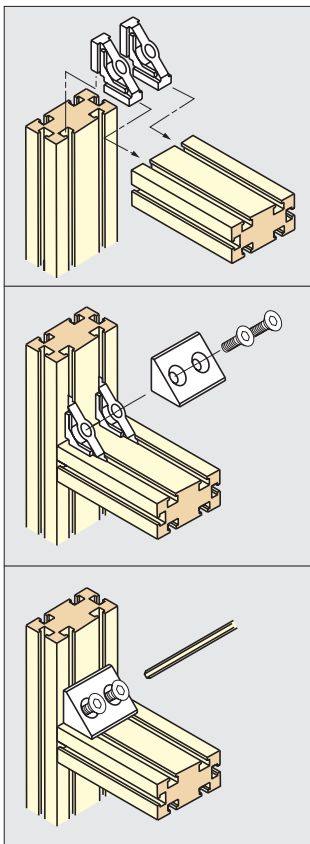

Simply insert PJ fastener into the slot.

Tighten flat head screw with allen key.

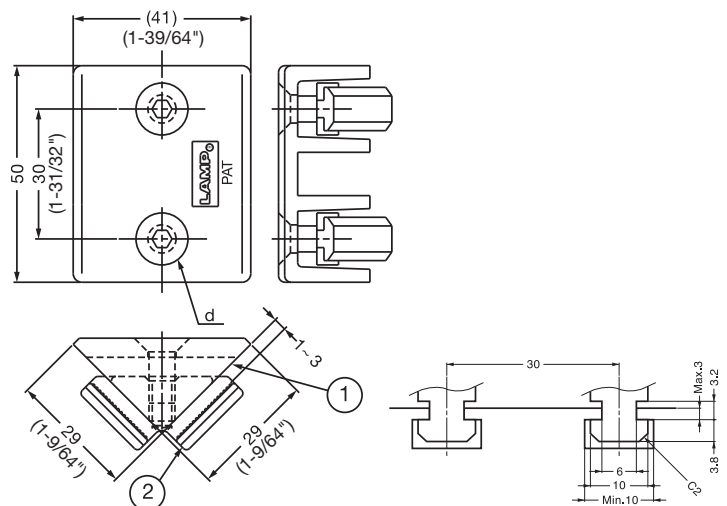
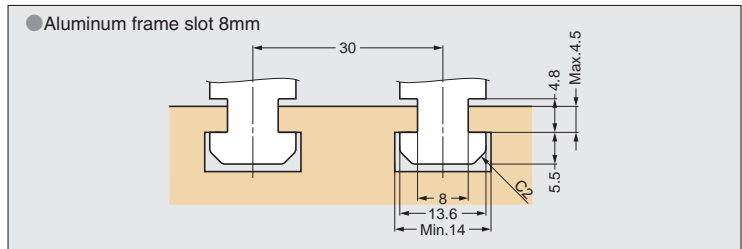
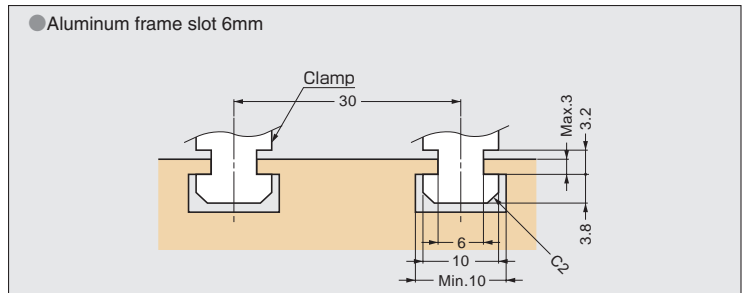

PJ-60W (For 6mm double slotted frame)

Item Code	Item Name	d <sub>1</sub>	Aluminum frame slot	A	B	C	D	d <sub>2</sub>	Recommended fastening torque
120-040-488	PJ-60W30	Without	6mm	41	50	29	1~3	M6×15	6N · m 61.2kgf · cm
120-040-556	PJ-60W30T	M4	6mm	41	50	29	1~3	M6×15	6N · m 61.2kgf · cm
120-040-552	PJ-80W30	Without	8mm	55	55	39	1.5~4.5	M8×20	13N · m 133kgf · cm
120-040-553	PJ-80W30T	M4	8mm	55	55	39	1.5~4.5	M8×20	13N · m 133kgf · cm

**FIXING NUTS FOR ALUMINUM PROFILE**



**AS-6M, 8M, 10M**

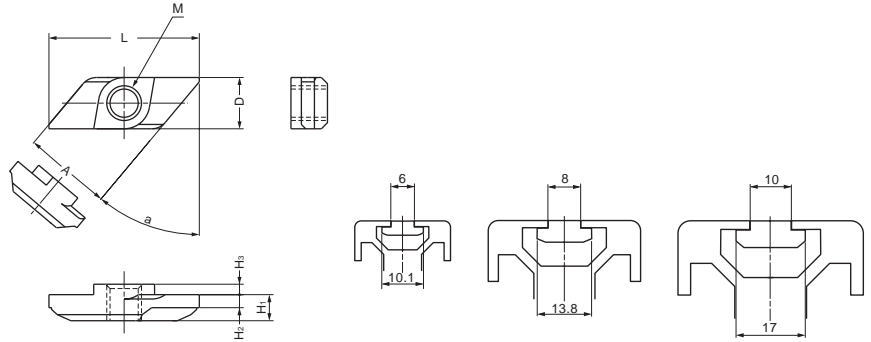
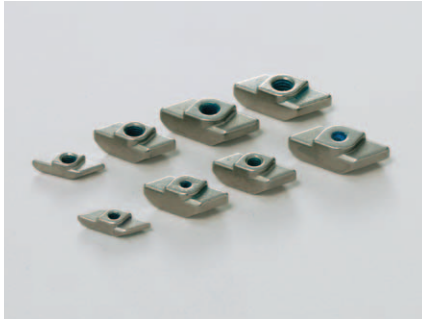

**Installation**

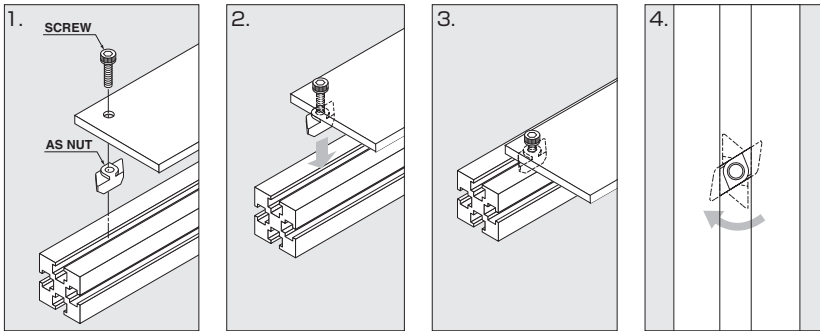

Item Code	Item Name	Spec.	M	L	D	A	H <sub>1</sub>	H <sub>2</sub>	H <sub>3</sub>	a	Material	Finish	Recommended fastening torque		Weight
120-040-676	AS-6M3	6mm	M3	17.3	5.9	10.1	3	1.5	1.2	40°	Stainless Steel (SUS316)	Polished	0.63N·m~1.14N·m	6.4kgf·cm~11.6kgf·cm	1.9g
120-040-684	AS-6M4	6mm	M4	17.3	5.9	10.1	3	1.5	1.2	40°	Stainless Steel (SUS316)	Polished	1.5N·m~2.7N·m	15.3kgf·cm~27.5kgf·cm	1.3g
120-040-677	AS-8M3	8mm	M3	20	7.9	13.8	6	3	1.5	32°	Stainless Steel (SUS316)	Polished	0.63N·m~1.14N·m	6.4kgf·cm~11.6kgf·cm	4.3g
120-040-685	AS-8M4	8mm	M4	20	7.9	13.8	6	3	1.5	32°	Stainless Steel (SUS316)	Polished	1.5N·m~2.7N·m	15.3kgf·cm~27.5kgf·cm	4.1g
120-040-686	AS-8M5	8mm	M5	20	7.9	13.8	6	3	1.5	32°	Stainless Steel (SUS316)	Polished	3N·m~5.4N·m	30.6kgf·cm~55.1kgf·cm	3.9g
120-040-678	AS-10M4	10mm	M4	24	9.9	17	6	3	1.8	32°	Stainless Steel (SUS316)	Polished	1.5N·m~2.7N·m	15.3kgf·cm~27.5kgf·cm	7g
120-040-687	AS-10M5	10mm	M5	24	9.9	17	6	3	1.8	32°	Stainless Steel (SUS316)	Polished	3N·m~5.4N·m	30.6kgf·cm~55.1kgf·cm	7g
120-040-679	AS-10M6	10mm	M6	24	9.9	17	6	3	1.8	32°	Stainless Steel (SUS316)	Polished	5.2N·m~9.2N·m	53kgf·cm~93.8kgf·cm	6g

**CORNER CAP PAT.P**



**AS-C**

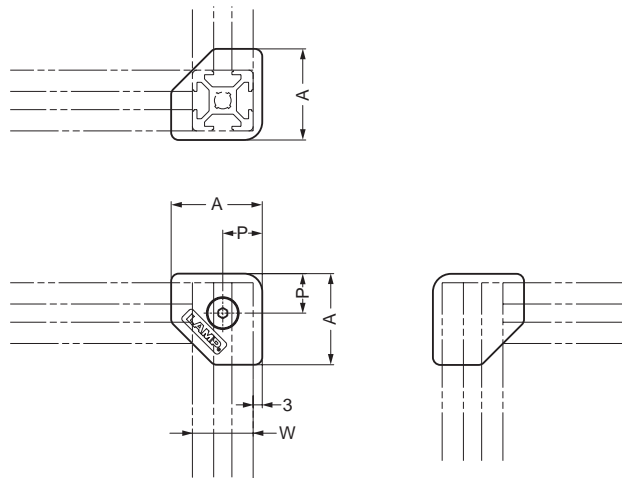
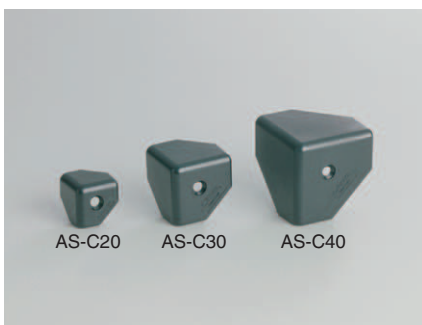

**Installation**

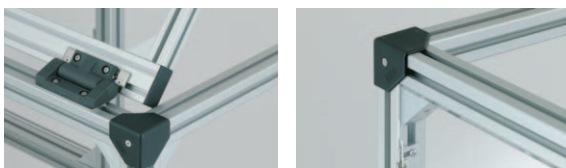

Item Code	Item Name	Frame Slot	A	P	W	Material	Color	Weight	1box	1carton
210-040-680	AS-C20	20×20mm Aluminum Frame Slot 6mm	30	13	20	Polyamide	Black	6g	200pcs	1600pcs
210-040-681	AS-C30	30×30mm Aluminum Frame Slot 8mm	43	18	30	Polyamide	Black	14g	50pcs	400pcs
210-040-682	AS-C40	40×40mm Aluminum Frame Slot 8mm, 40×40mm Aluminum Frame Slot 10mm	58	23	40	Polyamide	Black	29g	25pcs	200pcs



## TITANIUM HARDWARE



### Features:

- Density: ½ of Stainless Steel
- Nonpoisonous biocompatibility
- Non-magnetic metal
- Greater resistance than Stainless Steel to:
  - Chloride solutions (e.g. sea water)
  - Corrosive gas and liquid (e.g. dilute sulfuric hydrochloric acid)
  - Oxidizing acid (e.g. chromic and nitric)
  - Alkaline media (e.g. sodium hydroxide)
  - Stress corrosion cracking



## TITANIUM HARDWARE

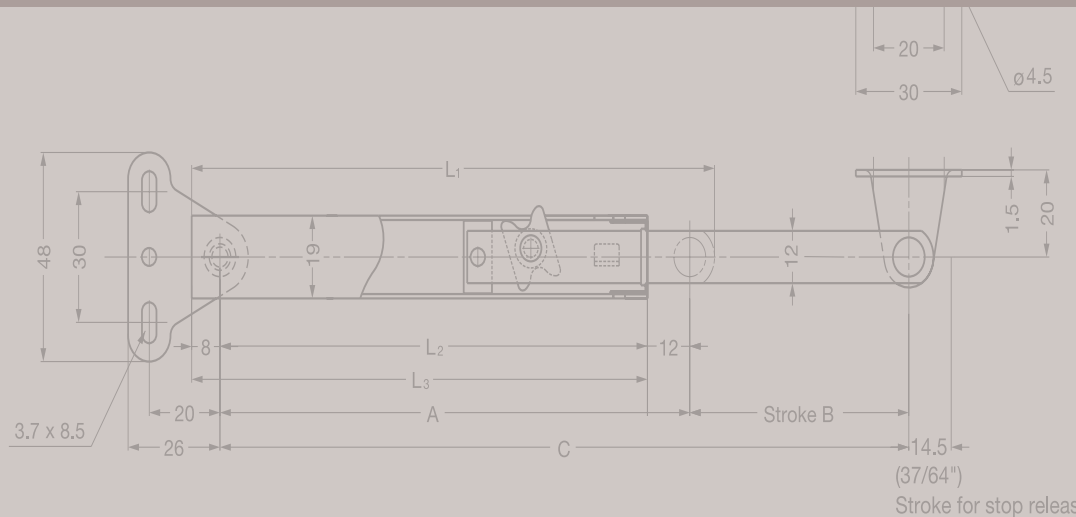

### WIRE PULL



### H42-CT-2, 4, 15

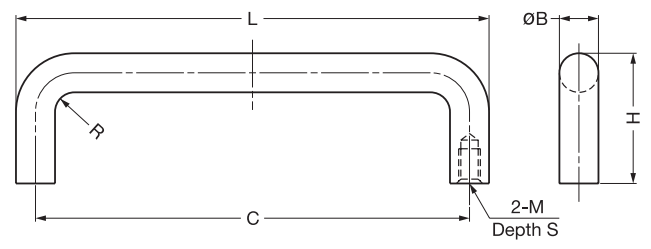

Material	Finish
Titanium	Polished

Item Code	Item Name	L	H	ØB	C	S	M	R	Weight (g)	Box (pcs)	Carton (pcs)
100-010-352	H42-CT-2	109	30	9	100	8	M5×0.8	4.5	37	20	80
100-010-351	H42-CT-4	130	40	10	120	8	M6×1	5	59	20	80
100-010-549	H42-CT-15	162	50	12	150	10	M8×1.25	6	105	20	80

### WIRE PULL



### H42-BT-2, 4, 15

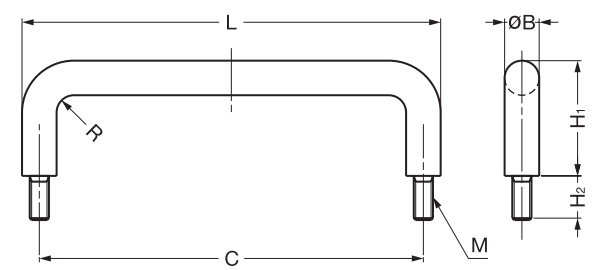

Material	Finish
Titanium	Polished

Item Code	Item Name	L	H <sub>1</sub>	H <sub>2</sub>	B	C	R	M	Weight (g)	Box (pcs)	Carton (pcs)
100-010-350	H42-BT-2	109	30	11	9	100	4.5	M5×0.8	40	20	80
100-010-349	H42-BT-4	130	40	11	10	120	5	M6×1	63	20	80
100-010-348	H42-BT-15	162	50	20	12	150	6	M8×1.25	122	20	80

**HANDLE**



**2LC-80Ti, 120Ti, 150Ti**

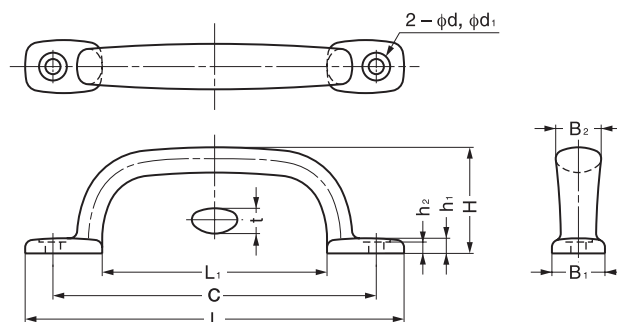

Material	Finish
Titanium	Polished

Item Code	Item Name	L	L <sub>1</sub>	C	B <sub>1</sub>	B <sub>2</sub>	H	h <sub>1</sub>	h <sub>2</sub>	t	d	d <sub>1</sub>	Weight (g)	Box (pcs)	Carton (pcs)
100-010-355	2LC-80 Ti	80	32	64	16	14	35	5.5	4	8	5	9.5	37	30	180
100-010-354	2LC-120 Ti	120	64	96	18	16	36	5.5	4.5	9	5	9.5	62	20	120
100-010-353	2LC-150 Ti	150	89	128	21	18	42	6	4.5	10	6	11	96	15	90

**RECESSED PULL**



**HH-AS2 Ti**

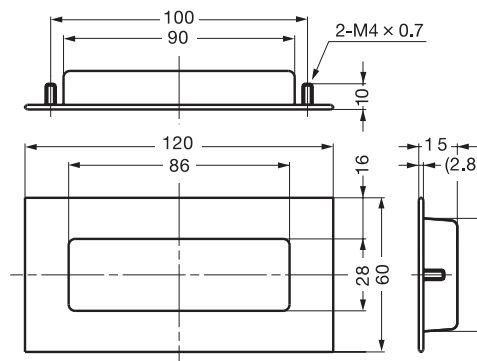
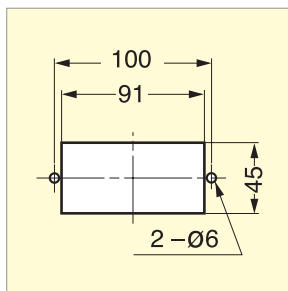

Item Code	Item Name	Weight (g)	Box (pcs)	Carton (pcs)
100-010-582	HH-AS2 Ti	30	12	240

Material	Finish
Titanium	Shotblast



# LID STAY

# L-195A Ti, 270A Ti

- Titanium stay to hold lid open.
- Lift up lid to release.
- Non-handed
- Only one stay per lid required.

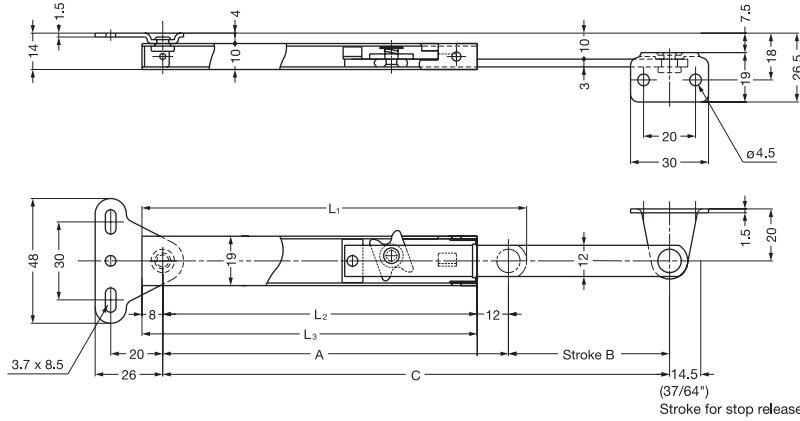

## With Concealed Hinge

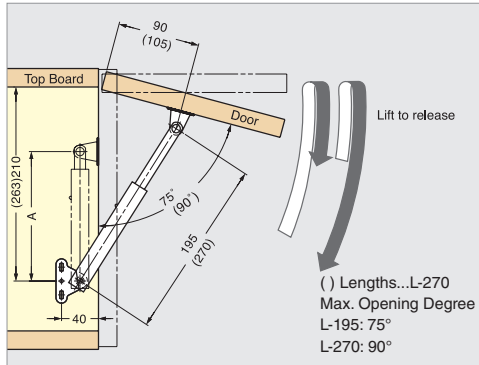

## With Piano / Butt Hinge

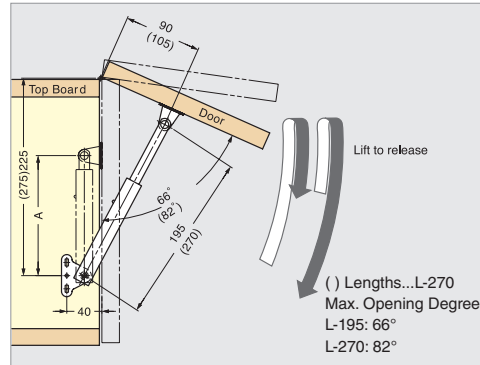

Material	Finish
Titanium	Satin

Item Code	Item Name	L <sub>1</sub>	L <sub>2</sub>	L <sub>3</sub>	A	B	C	Door Height	Weight (g)	Box (pcs)	Carton (pcs)
100-100-118	L-195A Ti	148(5-53/64")	121	129	133(5-15/64")	62	195(7-43/64")	250-350(9-27/32-13-25/32")	70	10	100
100-100-119	L-270A Ti	185(7-9/32")	158	166	170(6-11/16")	100	270(10-5/8")	320-500(12-19/32-19-11/16")	84	10	100

# HOOK



# FC-50 Ti, 65 Ti

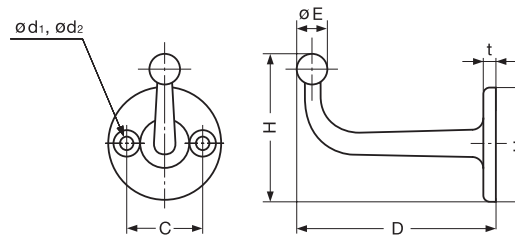

Material	Finish
Titanium	Shotblast

Item Code	Item Name	D	H	H <sub>1</sub>	t	C	d <sub>1</sub>	d <sub>2</sub>	E	Weight (g)	Box (pcs)	Carton (pcs)
100-020-121	FC-50 Ti	47(1-27/32")	37(1-29/64")	28	3	18.5	3.3	6.5	6.5	17	40	240
100-020-120	FC-65 Ti	65(2-9/16")	44(1-47/64")	35	4	22.5	4.2	8	8	34	30	180



**MAGNETIC CATCHES**  
(SEALED, THIN, SNAP-IN, etc.)

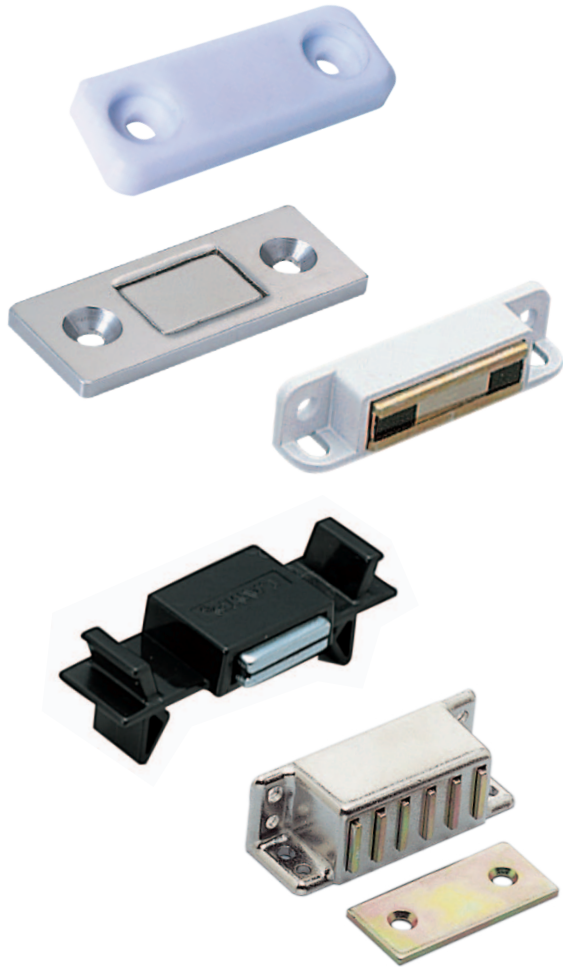

**TOUCH LATCHES**  
(MAGNETIC, NON-MAGNETIC)

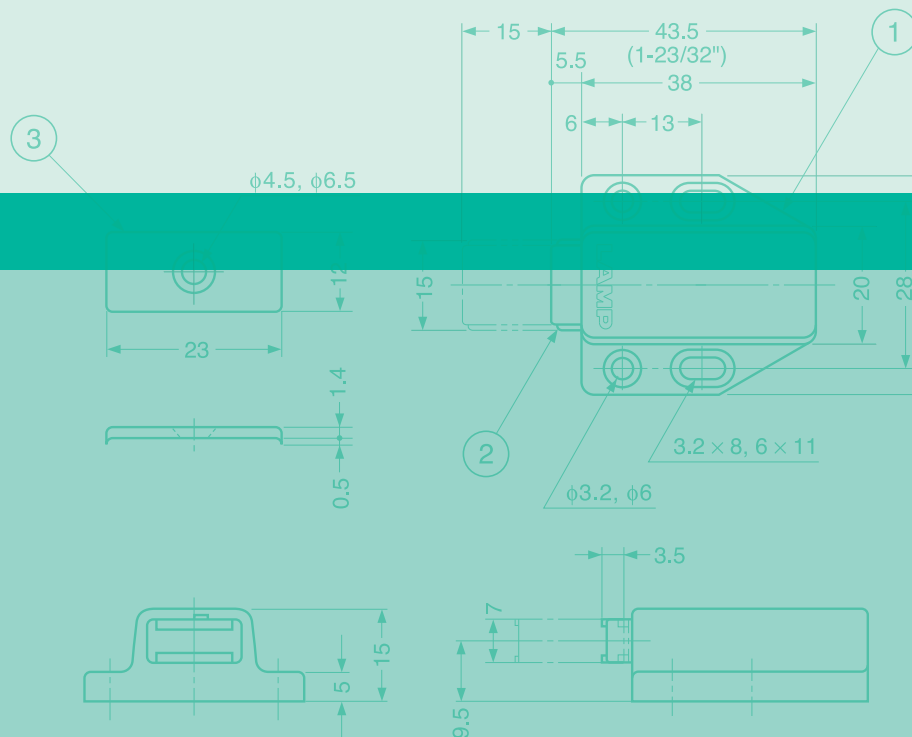

**MAGNETIC CATCHES**

SEALED MAGNETIC CATCHES

Picture	Item Name	Magnetic Force (kgf)	Page
	MC-JM45	3	34
	MC-JM50	3	34
	MC-JM63G	1.5 - 5	34

THIN MAGNETIC CATCHES

Picture	Item Name	Magnetic Force (kgf)	Page
	MC-111, 112, 113	1 - 5	42
	MC0750	2.5	42
	MC-YN003	1.7	42

ULTRA THIN & STRONG MAGNETIC CATCHES

Picture	Item Name	Magnetic Force (kgf)	Page
	MC-YN001	2.7	35
	MC-YN015S	2.3	35
	MC-158, MC-159	1.5 - 4	35

SNAP-IN MAGNETIC CATCHES

Picture	Item Name	Magnetic Force (kgf)	Page
	MC-YSW	1.2 - 3	39
	CM-2B	0.4	39
	MC-SS30	3	39
	MC-FS-17W	6	40
	MC-FP5S	4.5	40
	MC-FS, MC-FP	1.3 - 4.5	40
	MC-FS	1.5 - 7	41
	MC-IS4F	2.5	41
	MC-IS	1 - 2.5	41
	NB01	1.1	41

HIGH TEMPERATURE MAGNETIC CATCHES

Picture	Item Name	Magnetic Force (kgf)	Page
	MC0083HP	7.1 - 14.3	36
	MC-YN005HP	2 - 5.1	36

STRONG MAGNETIC CATCHES

Picture	Item Name	Magnetic Force (kgf)	Page
	MC-0083D	10	37
	MC-0083	7	37
	MC-YN005	3	37
	MCH	3 - 15	38
	MC-110NF	8	38
	SB11A-AA-1	7	44
	SB11B-AA-1	4	44
	MC12, MC12S	5 - 9	44

RUBBER MAGNETIC CATCHES

Picture	Item Name	Magnetic Force (gf/cm <sup>2</sup> )	Page
	NMS	390 - 550	50
	KMS	60 - 95	50

**GENERAL MAGNETIC CATCH**

Picture	Item Name	Magnetic Force (kgf)	Page
	MC0099	1.1 - 5.2	38
	MC-S78	0.8	43
	MC-S88	1.5	43
	MC-SM10	2	43
	MC50	3	45
	MC17,MC17S	3 - 3.7	45
	MC16,MC16S	0.5 - 1.2	45
	MC-SP	4.8 - 5.6	46
	MC-K	2.4 - 2.8	46
	MC-E	2 - 2.4	46
	MC0097	1.5 - 3.5	47
	MC200	3.5 - 5.5	47
	MC009	2.5 - 5	47
	MC-YS	1.2 - 3	48
	MC-84	3	48
	FM46S	2	48
	MC-EA	2	48
	MC-FM20S	1	49
	MC-FM20W	1	49
	TC-42	3.5	49
	MC-0051	5.5	49
	MC800	2	50
	MC-H	2.4 - 2.8	50

**COUNTERPLATE**

Picture	Item Name	Page
	W SERIES	51
	AS-68	51
	MC-JM49	51
	SP0207	51
	MC-YN001U	51
	YS-P05	51

**MAGNETIC TOUCH LATCHES**

Picture	Item Name	Magnetic Force (kgf)	Page
	ML-120	2.4	52
	ML-80	1.6	52
	ML-30S	1.2	53
	ML-30W	1.2	53
	MC-125	3	53

**SWITCH BUILT-IN MAGNETIC CATCHES**

Picture	Item Name	Magnetic Force (kgf)	Page
	SMC-101B, 103A/B	1 - 3	54
	MC-JM74SW-30	3.0	54

## SEALED MAGNETIC CATCH



## MC-JM45



Part Name	Material	Color
Body	Polypropylene	White/Black
Magnet	Neodymium	—

### ■ Strike (Option)

Item Code	Item Name	Page
140-050-122	MC-JMP45WT	—
140-029-241	MC-JMP45BL	—
140-050-149	MC-JM49	P.51
140-050-138	AS-68	P.51

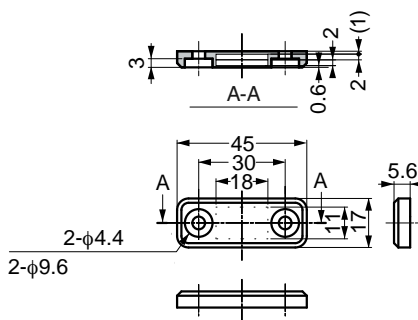

- Hermetically sealed, ideal for high corrosion environments.
- No metal-to-metal contact, ideal for cleanroom applications.
- Strong magnetic force.
- Optional Counter Plate:
  - Stainless Steel - MC-JM49, AS-68
  - Plastic Sealed - MC-JMP45
- Plastic sealed counter plate MC-JMP-45 is made of the same material and has similar dimensions as MC-JM45. Back is colored blue for distinction.

### ■ Body

Item Code	Item Name	Magnetic Force	Weight	Box	Carton
140-050-154	MC-JM45WT	29.4N	3kgf	8.5g	100pcs / 1,000pcs
140-029-240	MC-JM45BL	29.4N	3kgf	8.5g	100pcs / 1,000pcs

## SEALED MAGNETIC CATCH



## MC-JM50



Part Name	Material	Color
Body	Polyacetal	White/Black
Magnet	Neodymium	—

### ■ Strike (Option)

Item Code	Item Name
140-050-149	MC-JM49

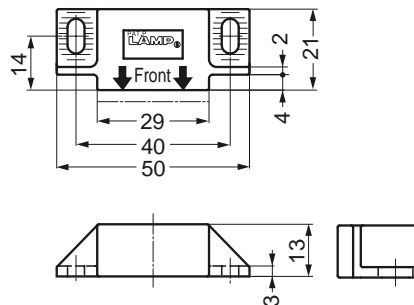

- Hermetically sealed, ideal for high corrosion environments.
- No metal-to-metal contact, ideal for cleanroom applications.
- Strong magnetic force.
- Optional Counter Plate:
  - Stainless Steel - MC-JM49, AS-68
  - Plastic Sealed - MC-JMP45

### ■ Body

Item Code	Item Name	Color	Magnetic Force	Weight	Box	Carton
140-050-156	MC-JM50WT	White	29.4N	3kgf	21g	24pcs / 480pcs
140-050-155	MC-JM50BL	Black	29.4N	3kgf	21g	24pcs / 480pcs

## SEALED MAGNETIC CATCH



## MC-JM63G



Part Name	Material	Color
Body	Polyacetal	Grey
Magnet	Neodymium	—

### ■ Strike (Option)

Item Code	Item Name	Page
140-050-122	MC-JMP45	—
140-050-149	MC-JM49	P.51
140-050-138	AS-68	P.51

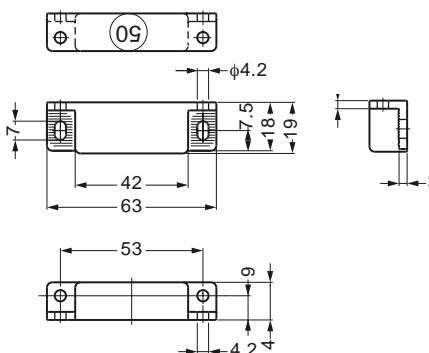

- Hermetically sealed, ideal for high corrosion environments.
- No metal-to-metal contact, ideal for cleanroom applications.
- Strong magnetic force.
- Optional Counter Plate:
  - Stainless Steel - MC-JM49, AS-68
  - Plastic Sealed - MC-JMP45

### ■ Body

Item Code	Item Name	Magnetic Force	Weight	Box	Carton
140-050-153	MC-JM63G-15	14.7N	1.5kgf	24g	50pcs / 500pcs
140-050-152	MC-JM63G-30	29.4N	3kgf	28g	50pcs / 500pcs
140-050-151	MC-JM63G-50	49N	5kgf	40g	50pcs / 250pcs

## ULTRA THIN MAGNETIC CATCH



## MC-YN001



MC-YN001



MC-YN001P

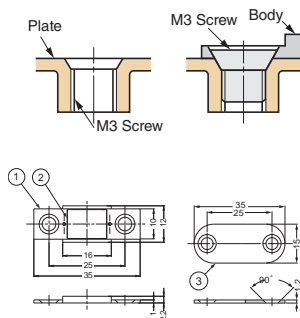

- Unique ultra thin magnetic catch design ideal for tight spaces.
- Counter plate included.
- Strong magnetic force.

Note: 1) Max. temperature: 80°C (176°F)  
 2) To avoid breakage, counter plate should not hit magnet.  
 3) Screw heads should not protrude above the base plate.

### Body

No.	Part Name	Material	Finish
①	Body	Steel	Nickel
②	Magnet	Neodymium	Nickel
③	Strike	Steel	Nickel

Item Code	Item Name	Spec.	Magnetic Force	Weight	Box	Carton
140-050-257	MC-YN001	Magnetic catch only	26.5N 2.7kgf	4g	100pcs	1,000pcs
140-050-000	MC-YN001P	Magnetic catch with strike plate & screws	26.5N 2.7kgf	7.5g	100pcs	1,000pcs

## ULTRA THIN STAINLESS STEEL MAGNETIC CATCH



## MC-YN015S



MC-YN015S



MC-YN015SP

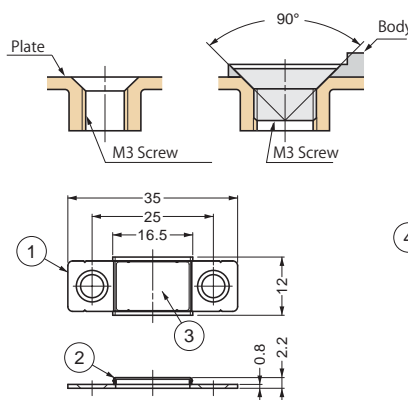

- Unique ultra thin magnetic catch design ideal for tight spaces.
- See MC-YN001 & MC-YN001P for details.
- Stainless steel for corrosion resistance.

No.	Part Name	Material	Finish
①	Body	Stainless Steel (Equivalent)	Polished
②	Cover	Stainless Steel (SUS304)	Plain
③	Magnet	Neodymium	Epoxy coating
④	Strike	Stainless Steel (Equivalent)	Polished

Item Code	Item Name	Spec.	Magnetic Force	Weight	Box	Carton
140-020-672	MC-YN015S	Magnetic catch only	22.5N 2.3kgf	3.6g	100pcs	2,000pcs
140-020-673	MC-YN015SP	Magnetic catch with strike plate & screws	22.5N 2.3kgf	7.3g	100pcs	2,000pcs

## ULTRA THIN & STRONG MAGNETIC CATCH



## MC-158, MC-159



No.	Part Name	Material	Finish
①	Body	Steel	Nickel
②	Magnet	Neodymium	Nickel

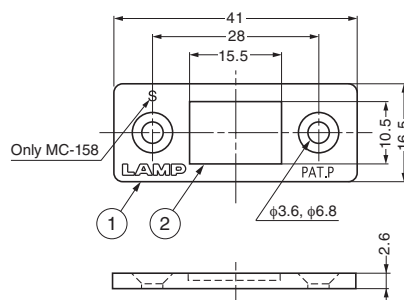

- Unique ultra thin magnetic catch design with extra strong magnetic force.

Note: 1) Max. temperature: 80°C  
 2) To avoid breakage, counterplate should not hit magnet.  
 3) Screw heads should not protrude above the base plate.

### Strike (Option)

Item Code	Item Name	Page
140-059-555	MC-YN001U	P.51

### Body

Item Code	Item Name	Magnetic Force	Weight	Box	Carton
140-050-014	MC-158	14.7N 1.5kgf	12g	200pcs	1,000pcs
140-058-061	MC-159	39N 4kgf	12g	200pcs	1,000pcs



# HIGH TEMPERATURE MAGNETIC CATCH



# MC0083HP

- Suitable for high temperature environments up to 250°C .
- Strong magnetic force.
- Optional counter plates:  
- AS-68

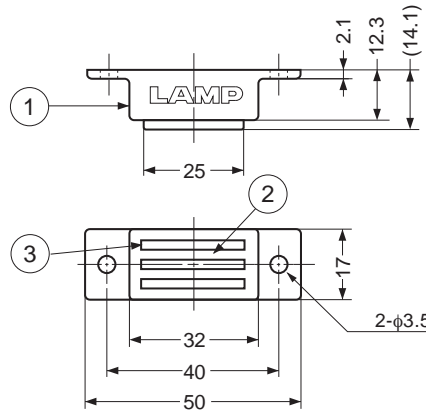

### ■Strike (Option)

Item Code	Item Name
140-050-138	AS-68

No.	Part Name	Material	Finish
①	Cover	Stainless Steel (SUS304)	Mirror
②	Magnet	Samarium Cobalt	Plain
③	Yoke	Stainless Steel (SUS430)	Mirror

### ■Body

Item Code	Item Name	Magnetic Force		Weight	Box	Carton
140-012-729	MC0083HP-70	70N	7.1kgf	40g	40pcs	400pcs
140-012-613	MC0083HP-140	140N	14.3kgf	40g	40pcs	400pcs

# HIGH TEMPERATURE MAGNETIC CATCH



# MC-YN005HP

- Suitable for high temperature environments up to 250°C .
- Optional counter plates:  
- MC-JM49

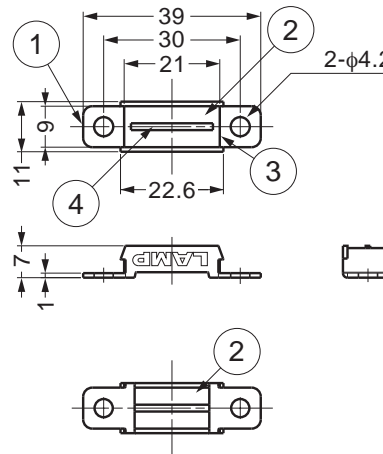

### ■Strike (Option)

Item Code	Item Name
140-050-149	MC-JM49

No.	Part Name	Material	Finish
①	Yoke	Stainless Steel (SUS430)	Mirror
②	Magnet	Samarium Cobalt	Plain
③	Cover	Stainless Steel (SUS304)	Plain
④	Yoke	Stainless Steel (SUS430)	Polished

### ■Body

Item Code	Item Name	Magnetic Force		Weight	Box	Carton
140-012-617	MC-YN005HP-20	20N	2kgf	11g	200pcs	1,000pcs
140-012-625	MC-YN005HP-50	50N	5.1kgf	11g	200pcs	1,000pcs

# HEAVY DUTY MAGNETIC CATCH



## MC-0083D

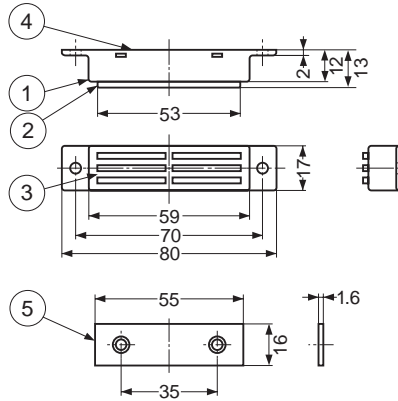

• Strong magnetic force.

No.	Part Name	Material	Finish
①	Body	Brass	Nickel
②	Yoke	Steel (SPCC)	Nickel
③	Magnet	Ferrite	—
④	Back Plate	Aluminum Alloy	Anodized
⑤	Strike	Steel (SPCC)	Nickel

Item Code	Item Name	Magnetic Force	Weight	Box	Carton
140-058-067	MC-0083D	98N 10kgf	63g	20pcs	200pcs

# HEAVY DUTY MAGNETIC CATCH



## MC-0083

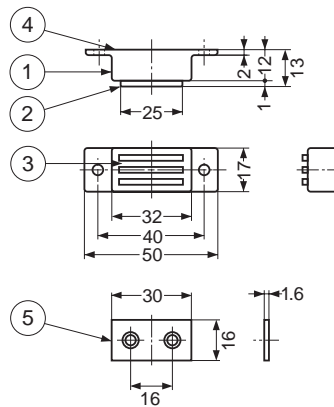

• Strong magnetic force.

No.	Part Name	Material	Finish
①	Body	Brass	Nickel
②	Yoke	Steel (SPCC)	Nickel
③	Magnet	Ferrite	—
④	Back Plate	Aluminum Alloy	Anodized
⑤	Strike	Steel (SPCC)	Nickel

Item Code	Item Name	Magnetic Force	Weight	Box	Carton
140-058-068	MC-0083	68.6N 7.0kgf	32g	40pcs	400pcs

# STAINLESS STEEL MAGNETIC CATCH



## MC-YN005

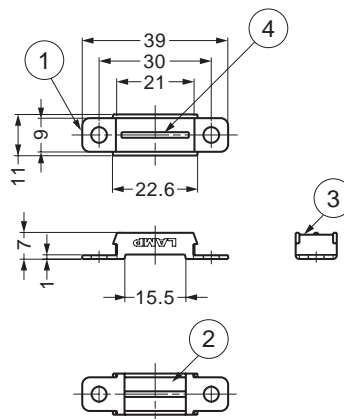

• Thin magnetic catch ideal for tight spaces.

No.	Part Name	Material	Finish
①	Yoke	Stainless Steel (SUS430)	Plain
②	Magnet	Ferrite	Plain
③	Cover	Stainless Steel (SUS304)	Plain
④	Yoke	Stainless Steel (SUS430)	Plain

Item Code	Item Name	Magnetic Force	Weight	Box	Carton
140-059-558	MC-YN005	29.4N 3kgf	9g	200pcs	1,000pcs



# HEAVY DUTY MAGNETIC CATCH



MCH

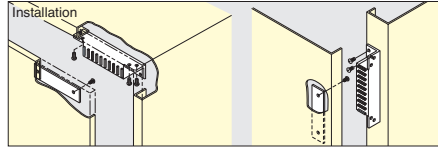
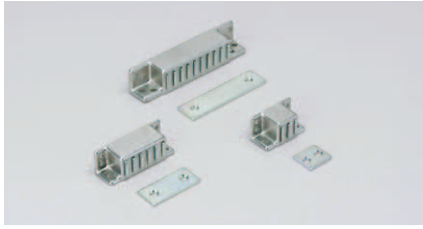

- Special design provides screw mounting options in 2 different planes.
- Strong and heavy duty magnetic catch.

No.	Part Name	Material	Finish/Color
①	Body	Zinc Alloy	Nickel
②	Magnet	Ferrite	—
③	Yoke	Steel	Zinc Chromate
④	Strike	Steel	Zinc Chromate

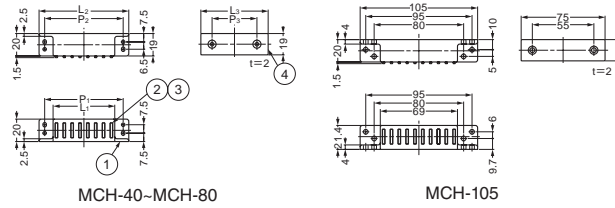

Item Code	Item Name	L <sub>1</sub>	L <sub>2</sub>	L <sub>3</sub>	P <sub>1</sub>	P <sub>2</sub>	P <sub>3</sub>	A	Magnetic Force	Weight	Box	Carton		
140-050-145	MCH-40	20	40	22	30	30	12	3	29N	3kgf	56g	60pcs	300pcs	
140-050-144	MCH-50	27	50	29	40	40	18	4	68N	7kgf	74g	50pcs	250pcs	
140-050-143	MCH-61	41	61	43	50	50	27	6	107N	11kgf	110g	40pcs	200pcs	
140-050-142	MCH-80	55	80	60	70	70	40	8	137N	14kgf	140g	30pcs	150pcs	
140-050-141	MCH-105	See drawing on the right								147N	15kgf	206g	24pcs	120pcs

# STRONG MAGNETIC CATCH



MC-110NF

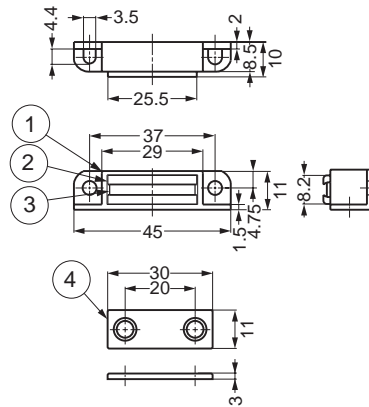
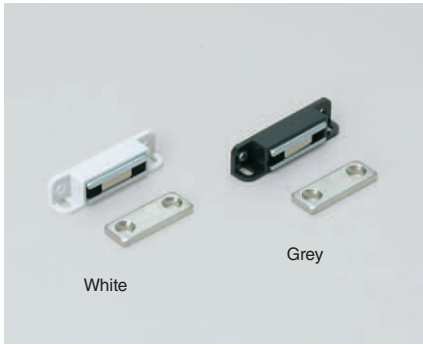

- Special design provides screw mounting options in 2 different planes.
- Strong magnetic force in a small casing.

No.	Part Name	Material	Finish/Color
①	Body	Polycarbonate	White/Grey
②	Yoke	Steel	Yellow Zinc Chromate
③	Magnet	Neodymium	—
④	Strike	Steel	Yellow Zinc Chromate

Item Code	Item Name	Color	Magnetic Force	Weight	Box	Carton	
140-050-335	MC-110NF-WT	White	78.4N	8kgf	10g	100pcs	800pcs
140-050-336	MC-110NF-GR	Grey	78.4N	8kgf	10g	100pcs	800pcs

# MAGNETIC CATCH



MC0099

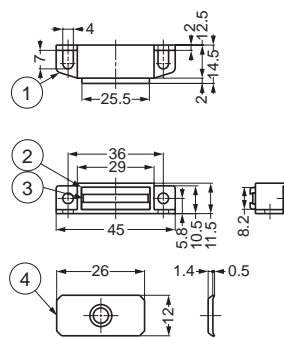

- Special design provides screw mounting options in 2 different planes.
- Three different magnetic forces available.

No.	Part Name	Material	Finish/Color
①	Body	ABS	White, Black, Grey
②	Yoke	Steel	Clear Zinc Chromate
③	Magnet	Ferrite	—
④	Strike	Steel	Clear Zinc Chromate

Item Code	Item Name	Color	Magnetic Force	Weight	Box	Carton	
140-050-501	MC0099BP	Black	10.8N	1.1kgf	16.3g	100pcs	1,000pcs
140-050-503	MC0099SBP	Black	37.2N	3.8kgf	16.3g	100pcs	1,000pcs
140-050-502	MC0099WP	White	10.8N	1.1kgf	16.3g	100pcs	1,000pcs
140-050-504	MC0099SWP	White	37.2N	3.8kgf	16.3g	100pcs	1,000pcs
140-050-505	MC0099GP	Grey	51.0N	5.2kgf	16.3g	100pcs	1,000pcs



# MAGNETIC CATCH (SNAP-IN TYPE)

# MC-YSW

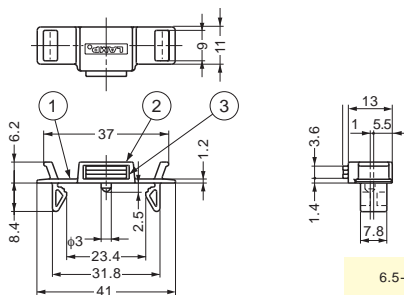
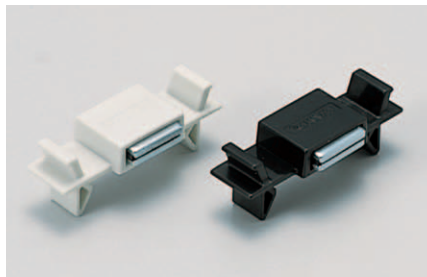

- Snap-in magnetic catch for sheet metal applications.
- Small size allows for tight spaces.
- Flex-tab allows for easy removal.

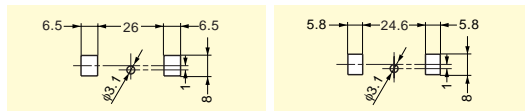

No.	Part Name	Material		Finish/Color	
		MC-YSW01	MC-YSW02	MC-YSW01	MC-YSW02
①	Body	Polyacetal		White, Black	
②	Yoke	Steel		Clear Zinc Chromate	Yellow Zinc Chromate
③	Magnet	Ferrite	Neodymium	—	Nickel

Item Code	Item Name	Color	Magnet	Magnetic Force	Weight	Box	Carton
140-050-001	MC-YSW01W	White	Ferrite	12N	1.2kgf	5g	100pcs, 1,000pcs
140-050-028	MC-YSW01B	Black	Ferrite	12N	1.2kgf	5g	100pcs, 1,000pcs
140-050-002	MC-YSW02W	White	Neodymium	29.4N	3kgf	5.5g	100pcs, 1,000pcs
140-050-029	MC-YSW02B	Black	Neodymium	29.4N	3kgf	5.5g	100pcs, 1,000pcs

# MINI MAGNETIC CATCH (SNAP-IN TYPE)



# CM-2B

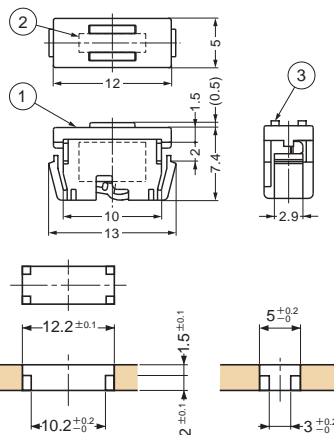

- Snap-in installation.
- Small size for light weight applications.

No.	Part Name	Material	Finish/Color
①	Body	Polyamide	Black
②	Magnet	Ferrite	—
③	Yoke	Steel	Black Zinc

Item Code	Item Name	Magnetic Force	Weight	Box
140-011-122	CM-2B	3.9N	0.4kgf	1g, 200pcs

# MAGNETIC CATCH (SNAP-IN TYPE)



# MC-SS30

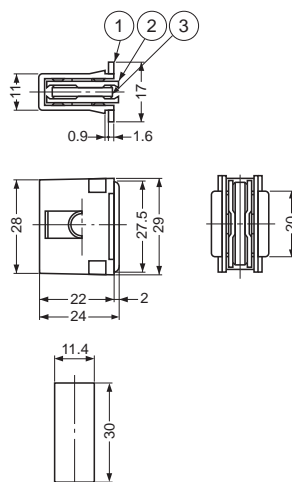
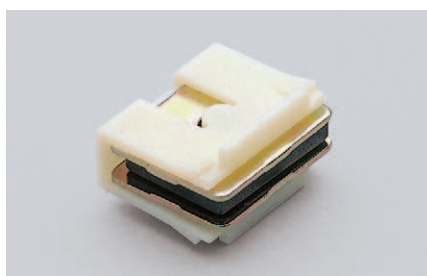

- Snap-in magnetic catch for sheet metal applications.
- Panel Thickness: 0.8mm

No.	Part Name	Material	Finish/Color
①	Body	ABS	Ivory
②	Yoke	Steel	Zinc Chromate
③	Magnet	Ferrite	—

Item Code	Item Name	Magnetic Force	Weight	Box	Carton
140-050-036	MC-SS30	29.4N	3kgf	22g, 60pcs	600pcs

# MAGNETIC CATCH (SNAP-IN TYPE)



## MC-FS17W

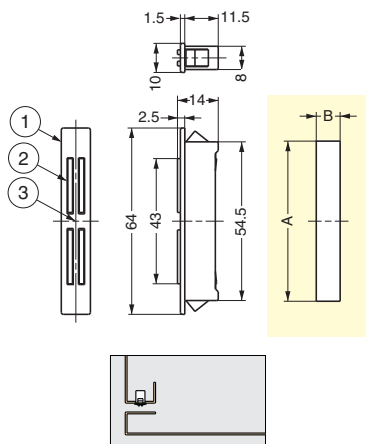

• Snap-in magnetic catch for sheet metal applications.

### ■Cut Out Dimensions

Door thickness	A	B
0.8	55	8.2
1	55	8.2
1.2	55.5	8.2
1.6	56	8.2
2	56.5	8.2

No.	Part Name	Material	Finish/Color
①	Body	ABS	White
②	Yoke	Steel	Zinc Chromate
③	Magnet	Ferrite	—

Item Code	Item Name	Magnetic Force	Weight	Box	Carton
140-050-334	MC-FS17W	58.8N	6kgf	18g	50pcs / 1,000pcs

# MAGNETIC CATCH



## MC-FP5S

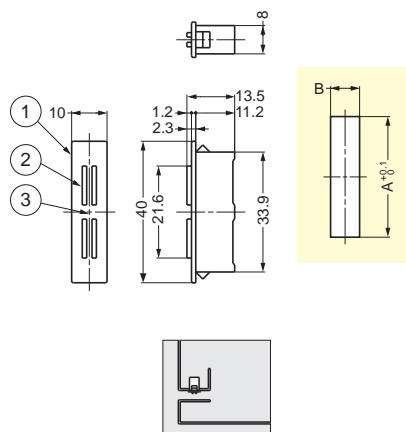
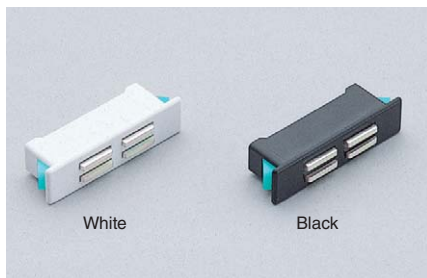

• Small design with a strong magnetic force.

### ■Cut Out Dimensions

Door Thickness	A	B
0.8	34.1	8.2
1.0	34.1	8.2
1.2	34.5	8.2
1.4	34.5	8.2
1.6	35	8.2
1.8	35.5	8.2
2.0	36.5	8.2

No.	Part Name	Material	Finish/Color
①	Body	ABS Plastic	White/Black
②	Yoke	Steel	Yellow Zinc Chromate
③	Magnet	Neodymium	—

Item Code	Item Name	Color	Magnetic Force	Weight	Box	Carton
140-050-268	MC-FP5SWT	White	44.1N	4.5kgf	9g	200pcs / 2,000pcs
140-050-269	MC-FP5SBL	Black	44.1N	4.5kgf	9g	200pcs / 2,000pcs

# MAGNETIC CATCH



## MC-FS, MC-FP

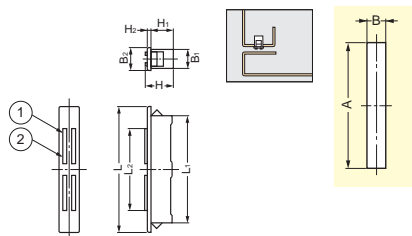
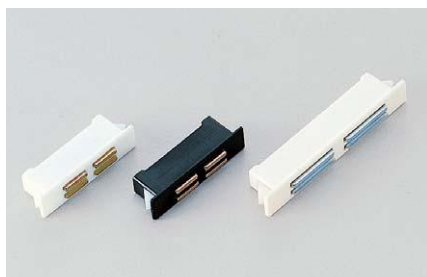

• Snap-in magnetic catch for sheet metal applications.

### ■Cut Out Dimensions

Door Thickness	MC-FS3		MC-FP5		MC-FS10	
	A	B	A	B	A	B
0.5	22.5	8.3	—	—	—	—
0.8	—	—	34.1	8.2	55	8.2
1.0	—	—	34.1	8.2	55	8.2
1.2	—	—	34.5	8.2	55.5	8.2
1.6	—	—	35	8.2	56	8.2
2	—	—	36.5	8.2	56.5	8.2

### ■Body

Item Code	Item Name	L	L <sub>1</sub>	L <sub>2</sub>	B <sub>2</sub>	B <sub>1</sub>	H	H <sub>1</sub>	H <sub>2</sub>	Magnetic Force	Weight	Color	Box	Carton
140-050-005	MC-FS3W	24.2	22.4	15	24.2	8.2	12.3	10.9	0.9	12.7N	1.3kgf	5g	White	60pcs / 2,160pcs
140-050-086	MC-FP5W	40	33.9	21.6	40	8	13.5	11.2	1.2	21.6N	2.2kgf	9g	White	200pcs / 2,000pcs
140-050-293	MC-FS10W	64	54.5	43	64	8	14	11.5	1.5	44.1N	4.5kgf	20g	White	50pcs / 1,000pcs
140-050-006	MC-FS3B	24.2	22.4	15	24.2	8.2	12.3	10.9	0.9	12.7N	1.3kgf	5g	Black	60pcs / 2,160pcs
140-050-087	MC-FP5B	40	33.9	21.6	40	8	13.5	11.2	1.2	21.6N	2.2kgf	9g	Black	200pcs / 2,000pcs
140-050-294	MC-FS10B	64	54.5	43	64	8	14	11.5	1.5	44.1N	4.5kgf	20g	Black	50pcs / 1,000pcs

No.	Part Name	Material	Finish/Color
①	Body	ABS Plastic	White/Black
②	Yoke	Steel	Yellow Zinc Chromate/ Clear Zinc Chromate

### ■Option(Strike)

Item Code	Item Name
140-059-555	MC-YN001U

# THIN MAGNETIC CATCH (SNAP-IN TYPE)



## MC-FS

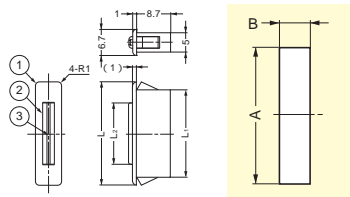

- Snap-in magnetic catch for sheet metal applications.
- Small size for tight spaces.

### Cut Out Dimensions

Item Name	Door Thickness	A	B
MC-FS-2	0.8	22.65 <sup>+0.15</sup> <sub>0</sub>	5 <sup>+0.2</sup> <sub>0</sub>
	1.0	22.8 <sup>+0.1</sup> <sub>0</sub>	5 <sup>+0.2</sup> <sub>0</sub>
	1.2	22.9 <sup>+0.1</sup> <sub>0</sub>	5 <sup>+0.2</sup> <sub>0</sub>
MC-FS-4	1.0	39.9 <sup>+0.2</sup> <sub>0</sub>	5 <sup>+0.2</sup> <sub>0</sub>
	1.2	40.5 <sup>+0.2</sup> <sub>0</sub>	5 <sup>+0.2</sup> <sub>0</sub>

No.	Part Name	Material	Finish/Color
①	Body	ABS	White
②	Yoke	Steel	Clear Zinc Chromate
③	Magnet	Ferrite, Neodymium	—

Item Code	Item Name	Material	L	L <sub>1</sub>	L <sub>2</sub>	Magnetic Force	Weight	Box	Carton	
140-013-016	MC-FS-2W	Ferrite	26.5	22.4	16	15N	1.5kgf	3.5g	400pcs	4,000pcs
140-013-017	MC-FS-2SW	Neodymium	26.5	22.4	16	34N	3.5kgf	3.5g	400pcs	4,000pcs
140-013-015	MC-FS-4W	Ferrite	45	39.6	30.3	25N	2.5kgf	5.8g	200pcs	2,000pcs
140-013-014	MC-FS-4SW	Neodymium	45	39.6	30.3	69N	7kgf	5.8g	200pcs	2,000pcs

# MAGNETIC CATCH



## MC-IS4F

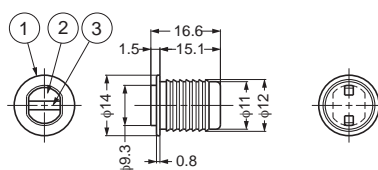

- Movable magnet yoke allows better contact with counterplate & ensures full magnetic force.

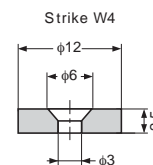
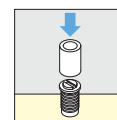

No.	Part Name	Material	Finish/Color
①	Body	Polyamide	White/Black
②	Yoke	Steel	Clear Zinc Chromate
③	Magnet	Ferrite	—

Item Code	Item Name	Color	Magnetic Force	Weight	Box	Carton	
140-050-519	MC-IS4FWTP	White	24.5N	2.5kgf	7.7g	100pcs	1,000pcs
140-050-520	MC-IS4FBLP	Black	24.5N	2.5kgf	7.7g	100pcs	1,000pcs

# MAGNETIC CATCH

## MC-IS

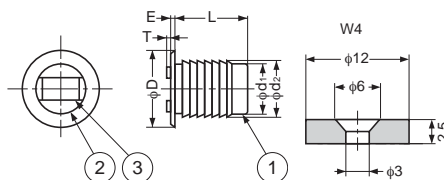
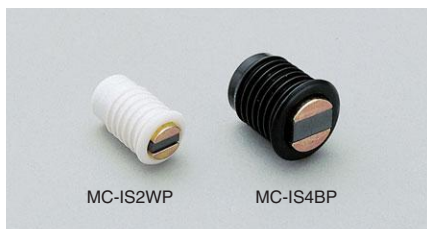

No.	Part Name	Material	Finish/Color
①	Body	Polyamide(S2) Polypropylene(S4)	White/Black
②	Yoke	Steel	Yellow Zinc Chromate
③	Magnet	Ferrite	—

Item Code	Item Name	D	L	E	T	d <sub>1</sub>	d <sub>2</sub>	Magnetic Force	Weight	Color	Box	Carton	
140-050-515	MC-IS2WP	10	13.8	1	0.7	8	8.6	9.8N	1.0kgf	4.7g	White	200pcs	5,000pcs
140-050-516	MC-IS4WP	14	14	0.7	1.2	11	12	24.5N	2.5kgf	7.7g	White	100pcs	3,000pcs
140-050-517	MC-IS2BP	10	13.8	1	0.7	8	8.6	9.8N	1.0kgf	4.7g	Black	200pcs	5,000pcs
140-050-518	MC-IS4BP	14	14	0.7	1.2	11	12	24.5N	2.5kgf	7.7g	Black	100pcs	3,000pcs

# MAGNETIC CATCH (OPTIONAL SNAP-IN HOLDER)



## NB01

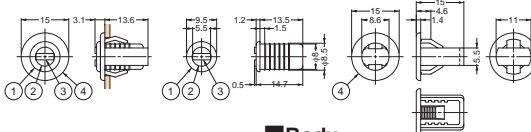
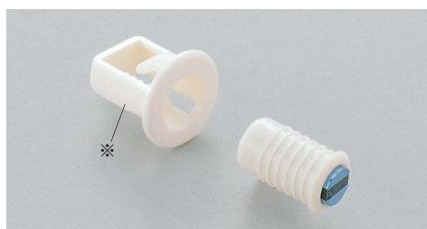

※NB01H (holder) is an option.

No.	Part Name	Material	Finish/Color
①	Body	Polyamide	White
②	Yoke	Steel	Clear Zinc Chromate
③	Magnet	Ferrite	—
④	Holder	Polyamide	White

Sheet metal thickness	Cut Out Dimensions
0.8~1.4	φ 11.5
1.5~3	φ 12

### Body

Item Code	Item Name	Magnetic Force	Weight	Box	Carton	
140-050-322	NB01	10.78N	1.1kgf	2g	500pcs	5,000pcs

### Holder (Option)

Item Code	Item Name	Weight
140-050-205	NB01H	0.5g

## MAGNETIC CATCH



## MC-111, 112, 113

• Low profile design is ideal for tight spaces.

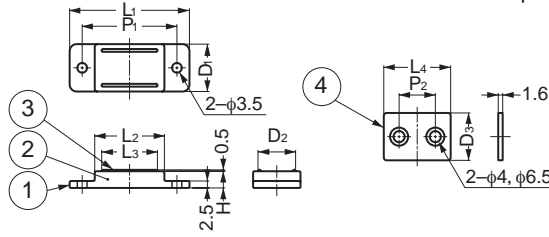

No.	Part Name	Material	Finish/Color
①	Body	ABS	Black, Ivory
②	Magnet	Ferrite	—
③	Yoke	Steel	Clear Zinc Chromate
④	Strike	Steel	Nickel

Item Code	Item Name	Color	Magnetic Force	L <sub>1</sub>	L <sub>2</sub>	L <sub>3</sub>	L <sub>4</sub>	D <sub>1</sub>	D <sub>2</sub>	D <sub>3</sub>	P <sub>1</sub>	P <sub>2</sub>	H	Weight	Box	Carton
140-059-463	MC-111B	Black	49N 5kgf	64	46	42	45	24.5	21	24	55	30	7	48g	50pcs	500pcs
140-059-465	MC-112B	Black	29.4N 3kgf	53	35	31	34	23.5	20	23	44	20	6.2	32g	50pcs	500pcs
140-059-467	MC-113B	Black	9.8N 1kgf	43	25	20	24	17	13.5	17	34	13	6	14g	100pcs	1,000pcs
140-059-464	MC-111I	Ivory	49N 5kgf	64	46	42	45	24.5	21	24	55	30	7	48g	50pcs	500pcs
140-059-466	MC-112I	Ivory	29.4N 3kgf	53	35	31	34	23.5	20	23	44	20	6.2	32g	50pcs	500pcs
140-059-468	MC-113I	Ivory	9.8N 1kgf	43	25	20	24	17	13.5	17	34	13	6	14g	100pcs	1,000pcs

## MAGNETIC CATCH



## MC0750

• Magnet is covered for better shock protection.

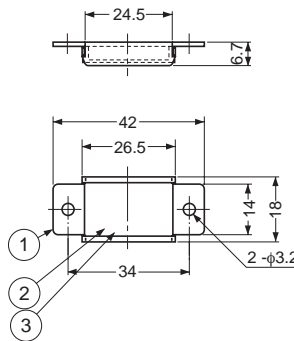

No.	Part Name	Material	Finish
①	Yoke	Steel	Nickel
②	Magnet	Ferrite	—
③	Cover	Stainless Steel	Polished

Item Code	Item Name	Magnetic Force	Weight	Box	Carton
140-057-000	MC0750	24.5N 2.5kgf	19g	150pcs	750pcs

## THIN MAGNETIC CATCH



## MC-YN003

• Thin magnetic catch ideal for tight spaces.

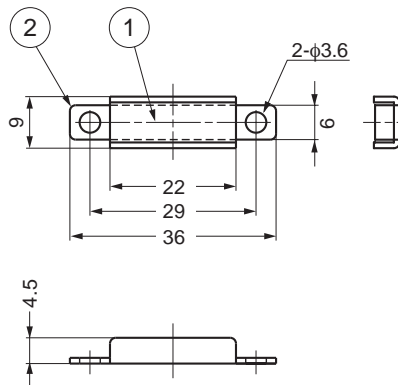
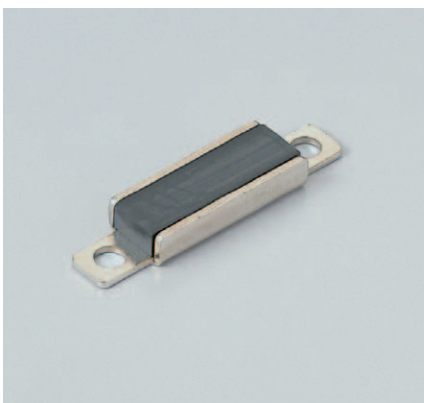

No.	Part Name	Material	Finish
①	Body	Steel	Nickel
②	Magnet	Ferrite	—

Item Code	Item Name	Magnetic Force	Weight	Box	Carton
140-059-540	MC-YN003	16.6N 1.7kgf	5g	500pcs	2,500pcs

# MAGNETIC CATCH



## MC-S78

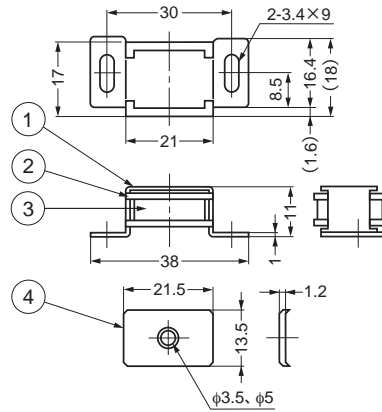

No.	Parts Name	Material	Finish
①	Body	Aluminum Alloy	Brown
②	Yoke	Steel	Clear Zinc Chromate
③	Magnet	Feritte	-
④	Strike	Steel	Clear Zinc Chromate

Item Code	Item Name	Magnetic Force	Weight	Screw	Box	Carton
140-050-030	MC-S78	7.8N	0.8kgf	17g	3	36pcs 720pcs

# MAGNETIC CATCH



## MC-S88

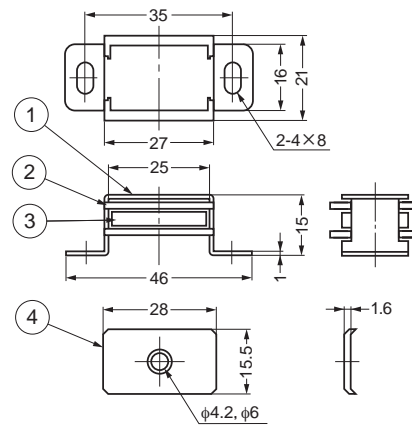

No.	Part Name	Material	Finish
①	Body	Aluminum Alloy	Plain
②	Yoke	Steel	Clear Zinc Chromate
③	Magnet	Ferrite	-
④	Strike	Steel	Clear Zinc Chromate

Item Code	Item Name	Magnetic Force	Weight	Screw	Box	Carton
140-050-032	MC-S88	14.7N	1.5kgf	28.5g	3	24pcs 720pcs

# MAGNETIC CATCH



## MC-SM10

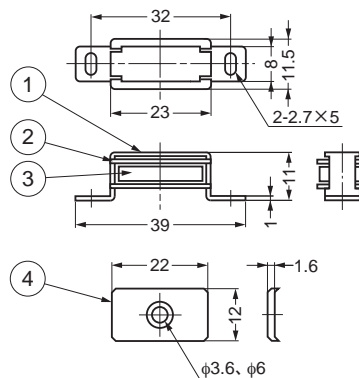

No.	Parts Name	Material	Finish
①	Body	Aluminum Alloy	Anodized
②	Yoke	Steel	Clear Zinc Chromate
③	Magnet	Feritte	-
④	Strike	Steel	Clear Zinc Chromate

Item Code	Item Name	Magnetic Force	Weight	Screw	Box	Carton
140-050-202	MC-SM10	20N	2kgf	12g	3	100pcs 1,000pcs

# MAGNETIC CATCH



## SB11A-AA-1



Different colors available on request.

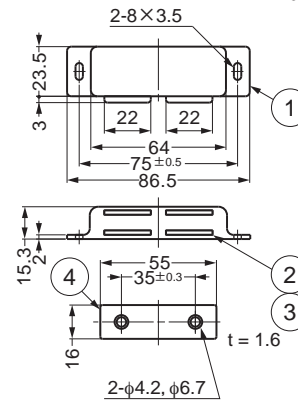

• Inside spring reduces the noise when the door closed.

No.	Part Name	Material	Finish
①	Body	Aluminum Alloy	Gold
②	Magnet	Ferrite	—
③	Yoke	Steel	Nickel
④	Strike	Steel	Nickel

Item Code	Item Name	Magnetic Force	Weight	Box	Carton
140-050-160	SB11A-AA-1	68.6N 7kgf	72.0g	25pcs	250pcs

# MAGNETIC CATCH

## SB11B-AA-1

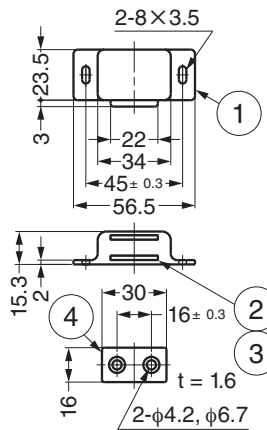

• Inside spring reduces the noise when the door closed.

No.	Part Name	Material	Finish
①	Body	Aluminum Alloy	Gold
②	Magnet	Ferrite	—
③	Yoke	Steel	Nickel
④	Strike	Steel	Nickel

Item Code	Item Name	Magnetic Force	Weight	Box	Carton
140-050-161	SB11B-AA-1	39.2N 4kgf	36.7g	30pcs	300pcs

# MAGNETIC CATCH



## MC12, MC12S

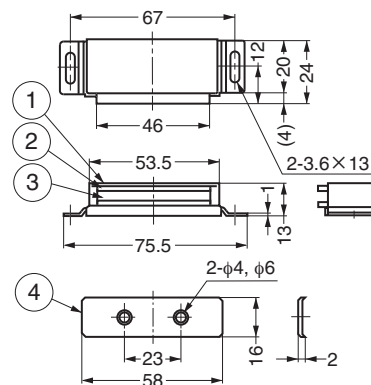

No.	Part Name	Material	Finish
①	Body	Aluminum Alloy	Gold
			Matte Brown
②	Yoke	Steel	Clear Zinc Chromate
③	Magnet	Ferrite	—
④	Strike	Steel	MC12:Clear Zinc Chromate
			MC12S:Chrome

Item Code	Item Name	Color	Magnetic Force	Weight	Box	Carton
140-050-093	MC12	Gold	49N 5kgf	72.9g	20pcs	200pcs
140-050-094	MC12S	Matte Brown	88.2N 9kgf	72.9g	20pcs	200pcs

# MAGNETIC CATCH

# MC50

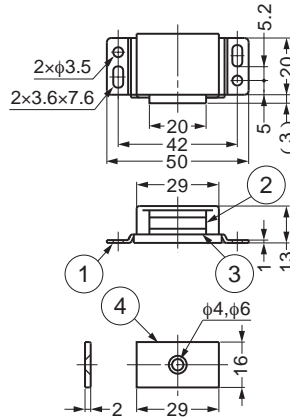
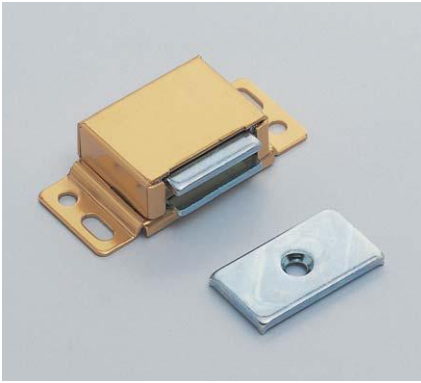

No.	Part Name	Material	Finish
①	Body	Aluminum Alloy	Gold
②	Magnet	Ferrite	-
③	Yoke	Steel	Clear Zinc Chromate
④	Strike	Steel	Clear Zinc Chromate

Item Code	Item Name	Magnetic Force	Weight	Box
140-099-636	MC50	29.4N	3kgf	36g 20pcs

# MAGNETIC CATCH



# MC17, MC17S

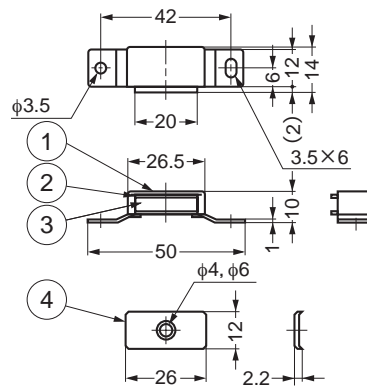

No.	Part Name	Material	Finish
①	Body	Aluminum Alloy	Gold Matte Brown
②	Yoke	Steel	Clear Zinc Chromate
③	Magnet	Ferrite	-
④	Strike	Steel	MC17: Clear Zinc Chromate MC17S: Chrome

Item Code	Item Name	Color	Magnetic Force	Weight	Box	Carton
140-050-097	MC17	Gold	29.4N	3kgf	15.3g	200pcs 1,600pcs
140-050-019	MC17S	Matte Brown	36.26N	3.7kgf	15.3g	200pcs 1,600pcs

# MAGNETIC CATCH



# MC16, MC16S

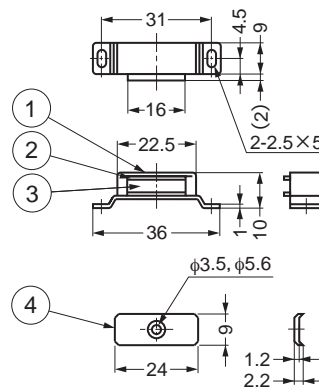
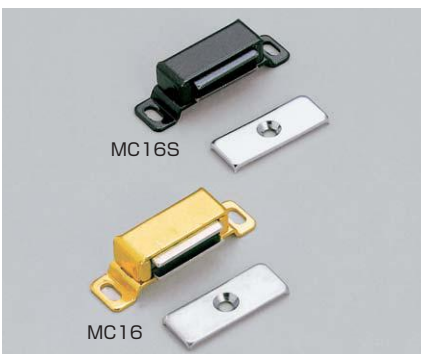

No.	Part Name	Material	Finish
①	Body	Aluminum Alloy	Gold Matte Brown
②	Yoke	Steel	MC16: Clear Zinc Chromate MC16S: GB
③	Magnet	Ferrite	-
④	Strike	Steel	MC16: Clear Zinc Chromate MC16S: Chrome

Item Code	Item Name	Finish	Magnetic Force	Weight	Box	Carton
140-050-095	MC16	Gold	4.8N	0.5kgf	7.5g	200pcs 2,000pcs
140-050-096	MC16S	Matte Brown	11.8N	1.2kgf	7.5g	200pcs 2,000pcs



# MAGNETIC CATCH



## MC-SP

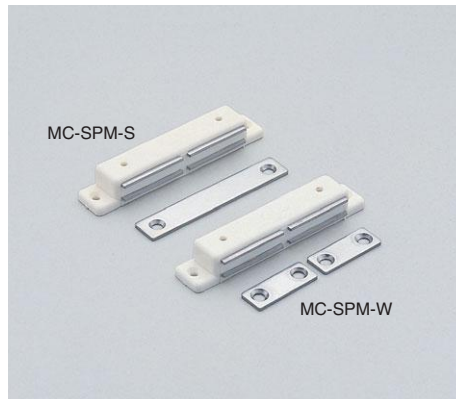

• Double plate option available for dual doors meeting in the center.

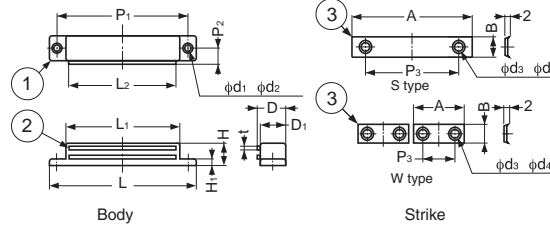

No.	Part Name	Material	Color
①	Body	PBT	White
②	Yoke	Stainless Steel (SUS430)	-
③	Strike	Stainless Steel (SUS430)	-

Item Code	Item Name	L	L <sub>1</sub>	L <sub>2</sub>	D	D <sub>1</sub>	H	H <sub>1</sub>	P <sub>1</sub>	P <sub>2</sub>	d <sub>1</sub>	d <sub>2</sub>	t	A	B	P <sub>3</sub>	d <sub>3</sub>	d <sub>4</sub>	Magnetic Force	Weight	Screw	Box	Carton	
140-050-070	MC-SPM-S	86	68.4	63	17	15	13	4	77	9.5	3	6	1.5	70	12	57	4.5	6.8	47.0N	4.8kgf	57g	4	12pcs	360pcs
140-050-071	MC-SPM-W	86	68.4	63	17	15	13	4	77	9.5	3	6	1.5	30	11	20	4.5	6.8	47.0N	4.8kgf	53.5g	6	12pcs	360pcs
140-050-072	MC-SPL-S	106	85.6	80	20.5	18	16	4	94	11.5	3	6	2	79	14	65	4.5	6.8	54.9N	5.6kgf	100g	4	6pcs	180pcs
140-050-073	MC-SPL-W	106	85.6	80	20.5	18	16	4	94	11.5	3	6	2	38	14	25	4.5	6.8	54.9N	5.6kgf	100g	6	6pcs	180pcs

# MAGNETIC CATCH



## MC-K



• Double plate option available for dual doors meeting in the center.

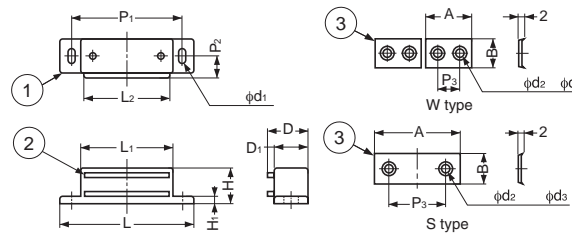

No.	Part Name	Material	Finish
①	Body	PBT	White
②	Yoke	Steel	Clear Zinc Chromate
③	Strike	Steel	Chrome

Item Code	Item Name	L	L <sub>1</sub>	L <sub>2</sub>	D	D <sub>1</sub>	H	H <sub>1</sub>	P <sub>1</sub>	P <sub>2</sub>	d <sub>1</sub>	A	B	P <sub>3</sub>	d <sub>2</sub>	d <sub>3</sub>	Magnetic Force	Weight	Screw	Box	Carton	
140-050-290	MC-KM-S	50.5	33	30	17	15	12	3	42	10	3.2x6.2	30	11.5	20	4.2	6.7	23.5N	2.4kgf	26g	4	12pcs	720pcs
140-050-291	MC-KL-S	60	42	38	18	15	16	3.2	50	10.5	3.2x6	38	14	25	4.3	6.4	27.4N	2.8kgf	45g	4	12pcs	360pcs
140-050-292	MC-KL-W	60	42	38	18	15	16	3.2	50	10.5	3.2x6	20	13	10	4.3	6.4	27.4N	2.8kgf	45g	6	12pcs	360pcs

# MAGNETIC CATCH



## MC-E

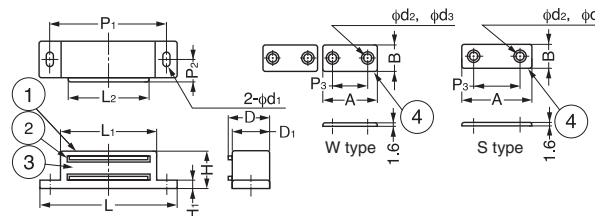

No.	Part Name	Material	Finish/Color
①	Body	Polyethylene	White
②	Yoke	Steel	Yellow Zinc Chromate
③	Magnet	Ferrite	-
④	Strike	Steel	Yellow Zinc Chromate

Item Code	Item Name	L	L <sub>1</sub>	L <sub>2</sub>	D	D <sub>1</sub>	H	H <sub>1</sub>	P <sub>1</sub>	P <sub>2</sub>	d <sub>1</sub>	A	B	P <sub>3</sub>	d <sub>2</sub>	d <sub>3</sub>	Magnetic Force	Weight	Screw	Box	Carton	
140-050-058	MC-EM-S	49.5	33	28	16	15	14	4	41.5	9	3.5x6	30	11	20	4.8	6.5	19.6N	2kgf	26g	4	24pcs	720pcs
140-050-059	MC-EL-S	60	41	35	18	16	16	3.5	50	9.5	3.5x6	38	14	25	4.3	6.4	23.5N	2.4kgf	38g	4	24pcs	360pcs
140-050-060	MC-EL-W	60	41	35	18	16	16	3.5	50	9.5	3.5x6	20	13	10	4.4	6.4	23.5N	2.4kgf	38g	6	24pcs	360pcs



# MAGNETIC CATCH



## MC0097

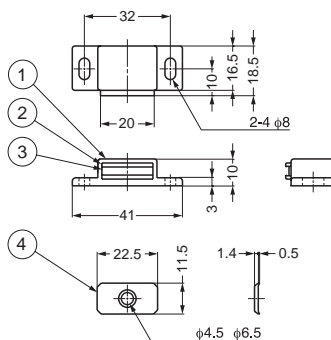

Item Code	Item Name	Color	Magnetic Force	Weight	Box	Carton
140-050-331	MC0097W	White	14.7N	1.5kgf	12g	100pcs 1,000pcs
140-050-329	MC0097W-1	White	34.3N	3.5kgf	12g	100pcs 1,000pcs
140-050-332	MC0097B	Black	14.7N	1.5kgf	12g	100pcs 1,000pcs
140-050-330	MC0097B-1	Black	34.3N	3.5kgf	12g	100pcs 1,000pcs

No.	Part Name	Material	Finish/Color
①	Body	Polyethylene	Black, White
②	Yoke	Steel	Clear Zinc Chromate
③	Magnet	Ferrite	-
④	Strike	Steel	Clear Zinc Chromate

# MAGNETIC CATCH

## MC200

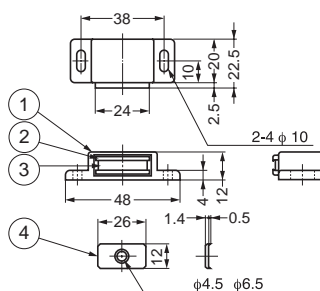
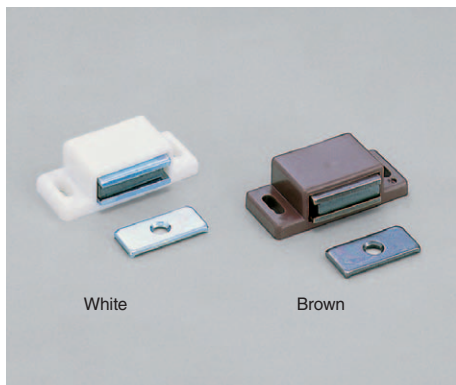

Item Code	Item Name	Color	Magnetic Force	Weight	Box	Carton
140-058-030	MC200W	White	34.3N	3.5kgf	20g	100pcs 1,000pcs
140-058-032	MC200W-1	White	53.9N	5.5kgf	20g	100pcs 1,000pcs
140-058-031	MC200BR	Brown	34.3N	3.5kgf	20g	100pcs 1,000pcs
140-058-033	MC200BR-1	Brown	53.9N	5.5kgf	20g	100pcs 1,000pcs

No.	Part Name	Material	Finish/Color
①	Body	Polyethylene	White, Brown
②	Yoke	Steel	Bronze/Clear Zinc Chromate
③	Magnet	Ferrite	-
④	Strike	Steel	Bronze/Clear Zinc Chromate

# MAGNETIC CATCH

## MC009

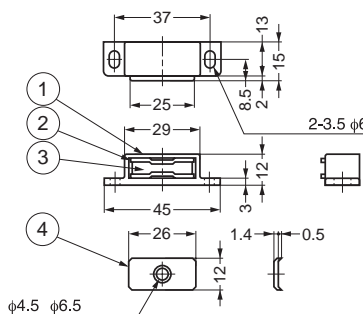
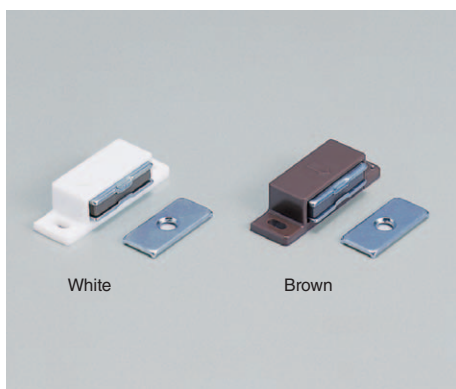

Item Code	Item Name	Color	Magnetic Force	Weight	Box	Carton
140-040-008	MC009W	White	24.5N	2.5kgf	17g	100pcs 1,000pcs
140-058-010	MC009BR	Brown	24.5N	2.5kgf	17g	100pcs 1,000pcs
140-040-009	MC009SW	White	49N	5kgf	17g	100pcs 1,000pcs
140-058-012	MC009SBR	Brown	49N	5kgf	17g	100pcs 1,000pcs

No.	Part Name	Material	Finish/Color
①	Body	Polyethylene	White, Brown
②	Yoke	Steel	Clear Zinc Chromate
③	Magnet	Ferrite	-
④	Strike	Steel	Clear Zinc Chromate

## MINI MAGNETIC CATCH



## MC-YS

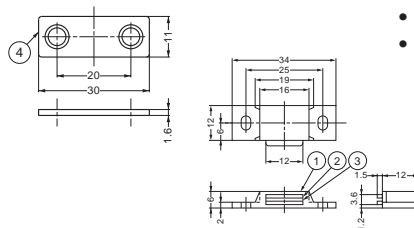

- Mini magnetic catch is ideal for tight spaces.
- Strong or light magnetic force available.

No.	Part Name	Material		Finish
		MC-YS001/001P	MC-YS002/002P	
①	Body	PBT		White
②	Yoke	Steel		Zinc chromate
③	Magnet	Neodymium	Ferrite	Nickel
④	Strike	Steel		Zinc chromate

Item Code	Item Name	Specification	Magnetic Force	Weight	Box	Carton
140-050-298	MC-YS001	Magnet only	29.4N	3kgf	6g	50pcs 500pcs
140-050-296	MC-YS001P	Magnet, strike & screw	29.4N	3kgf	12g	50pcs 500pcs
140-050-297	MC-YS002	Magnet only	12N	1.2kgf	5g	50pcs 250pcs
140-050-295	MC-YS002P	Magnet, strike & screw	12N	1.2kgf	14g	50pcs 250pcs

## MAGNETIC CATCH



## MC-84



- Adjustable magnet position (5.5mm)

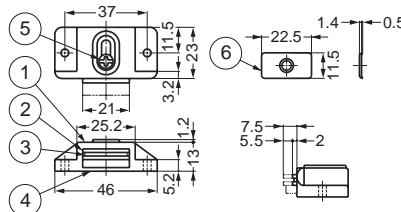

No.	Part Name	Material	Finish/Color	
			BR	BG
①	Body	ABS	Brown	Beige
②	Yoke	Steel	Bronze	Nickel
③	Magnet	Ferrite	-	-
④	Back Plate	ABS	Brown	White
⑤	Screw	Steel	Bronze	Nickel
⑥	Strike	Steel	Bronze	Nickel

Item Code	Item Name	Color	Magnetic Force	Weight	Box	Carton
140-058-046	MC-84BR	Brown	29.4N	3kgf	18g	100pcs 1,000pcs
140-058-047	MC-84BG	Beige	29.4N	3kgf	18g	100pcs 1,000pcs

## MAGNETIC CATCH

## FM46S

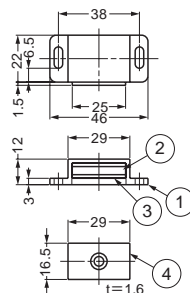

- Limited stock available:  
please contact your local dealer for projects.

No.	Part Name	Material	Finish/Color
①	Body	Polypropylene	White
②	Magnet	Ferrite	-
③	Yoke	Steel	Clear Zinc Chromate
④	Strike	Steel	Clear Zinc Chromate

Item Code	Item Name	Magnetic Force	Weight	Box
140-059-462	FM46S	19.6N	2kgf	31g 100pcs

## MAGNETIC CATCH



## MC-EA

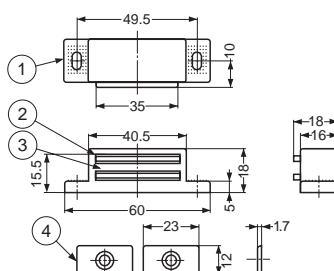

No.	Part Name	Material	Finish/Color
①	Body	Polyethylene	Brown
②	Yoke	Steel	Yellow Zinc Chromate
③	Magnet	Ferrite	-
④	Strike	Steel	Bronze

Item Code	Item Name	Magnetic Force	Weight	Screw	Box	Carton
140-050-061	MC-EA	19.6N	2kgf	40g	4 24pcs	360pcs

# MAGNETIC CATCH



# MC-FM20S

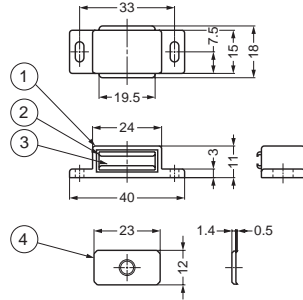
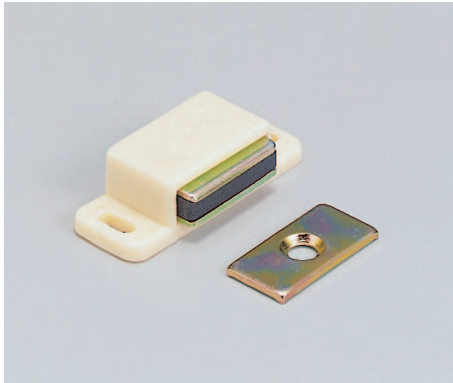

No.	Part Name	Material	Finish/Color
①	Body	Polyethylene	Ivory
②	Yoke	Steel	Zinc Chromate
③	Magnet	Ferrite	-
④	Strike	Steel	Zinc Chromate

Item Code	Item Name	Magnetic Force	Weight	Screw	Box	Carton
140-050-048	MC-FM20S	9.8N	1kgf	15g	3	36pcs / 720pcs

# MAGNETIC CATCH



# MC-FM20W

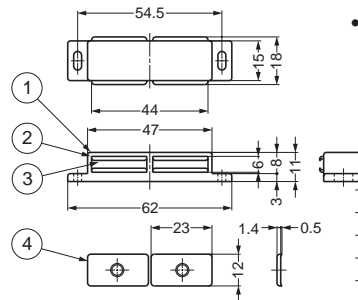

• Double catch for dual doors that meet in the center.

No.	Part Name	Material	Finish/Color
①	Body	Polyethylene	Ivory
②	Yoke	Steel	Zinc Chromate
③	Magnet	Ferrite	-
④	Strike	Steel	Zinc Chromate

Item Code	Item Name	Magnetic Force	Weight	Screw	Box	Carton
140-050-049	MC-FM20W	9.8N	1kgf	30g	4	24pcs / 480pcs

# MAGNETIC CATCH



# TC-42

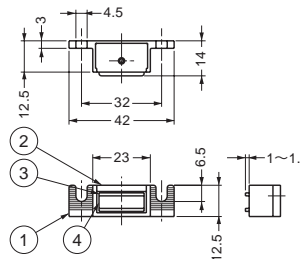
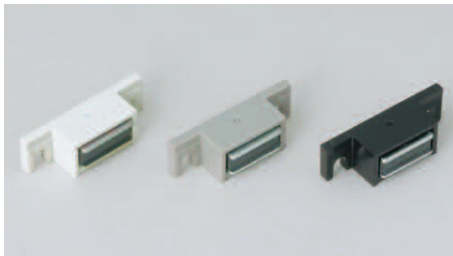

No.	Part Name	Material	Finish/Color
①	Body	ABS	White, Black, Grey
②	Cover	ABS	White, Black, Grey
③	Yoke	Steel	Yellow Zinc Chromate
④	Magnet	Ferrite	-

Item Code	Item Name	Color	Magnetic Force	Weight	Box	Carton
140-050-350	TC-42W	White	34.3N	3.5kgf	10g	80pcs / 1,600pcs
140-400-003	TC-42B	Black	34.3N	3.5kgf	10g	80pcs / 1,600pcs
140-050-333	TC-42G	Grey	34.3N	3.5kgf	10g	80pcs / 1,600pcs

# MAGNETIC CATCH

# MC-0051

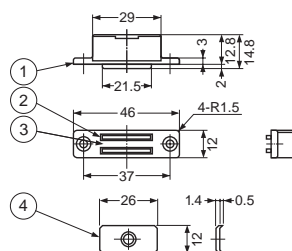
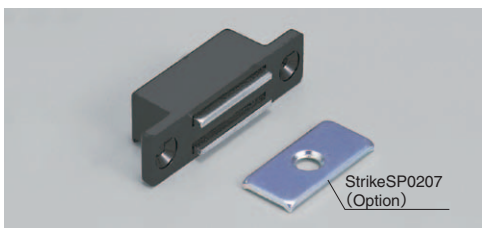

No.	Part Name	Material	Finish / Color
①	Body	ABS	Black
②	Yoke	Steel	Clear Zinc Chromate
③	Magnet	Ferrite	-
④	Strike	Steel	Clear Zinc Chromate

■Body

Item Code	Item Name	Magnetic Force	Weight	Box	Carton
140-053-503	MC-0051	53.9N	5.5kgf	17g	50pcs / 500pcs

■Option (Strike)

Item Code	Item Name
140-050-323	SP0207

# MAGNETIC CATCH

# MC800

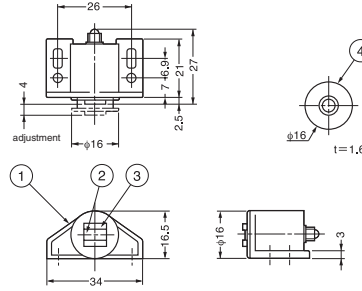

• 4mm Depth adjustment.

No.	Part Name	Material	Finish/Color
①	Body	Polypropylene	Brown
②	Magnet	Ferrite	-
③	Yoke	Steel	Bronze
④	Strike	Steel	Bronze

Item Code	Item Name	Magnetic Force	Weight	Box	Carton
140-058-048	MC800	19.6N	2kgf	8g	100pcs

# STRONG MAGNETIC CATCH



# MC-H

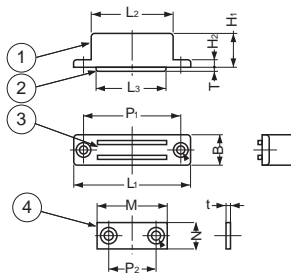

• Inside spring reduces the noise when the door closed.

No.	Part Name	Material	Finish
①	Body	Polyamide	Brown
②	Yoke	Steel	Yellow Zinc Chromate
③	Magnet	Ferrite	-
④	Strike	Steel	Chrome

Item Code	Item Name	L1	L2	L3	B	H1	H2	T	P1	d1	d2	M	N	t	P2	d3	d4	Magnetic Force	Weight	Screw	Box	Carton	
140-050-052	MC-HM	50	35	30	13	14.5	3.2	2	41.7	3.2	6	30	11.5	2	20.2	4.4	7	23.5N	2.4kgf	27g	4	12pcs	360pcs
140-051-111	MC-HL	60	42	38	15.5	17	4.3	2.5	50.8	3.2	6	38	14	2	25.2	4.4	7	27.4N	2.8kgf	47g	4	12pcs	180pcs

# HIGH POWER RUBBER MAGNETIC CATCH



# NMS

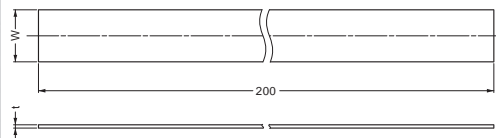
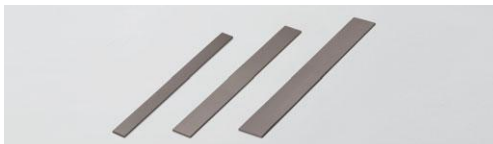

• Easy to cut length.  
• Easy to apply with glue.

Item Code	Item Name	Material	W	t	Magnetic Force	Magnetic Force	Weight	Box
140-021-209	NMS-1-200	Nitrile rubber (NBR) / Neodymium	12.7	0.8	3.8N/cm <sup>2</sup>	0.39kgf/cm <sup>2</sup>	10g	500pcs
140-021-210	NMS-2-200		19.1	0.8	3.8N/cm <sup>2</sup>	0.39kgf/cm <sup>2</sup>	16g	500pcs
140-021-211	NMS-3-200		25.4	0.8	3.8N/cm <sup>2</sup>	0.39kgf/cm <sup>2</sup>	21g	500pcs
140-021-212	NMS-4-200		12.7	1.5	5.4N/cm <sup>2</sup>	0.55kgf/cm <sup>2</sup>	19g	500pcs
140-021-213	NMS-5-200		19.1	1.5	5.4N/cm <sup>2</sup>	0.55kgf/cm <sup>2</sup>	30g	250pcs
140-021-214	NMS-6-200		25.4	1.5	5.4N/cm <sup>2</sup>	0.55kgf/cm <sup>2</sup>	39g	250pcs

# MAGNETIC CATCH (RUBBER ROLL TYPE)



# KMS

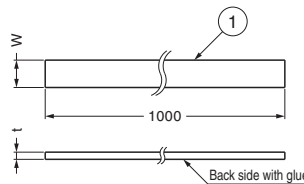
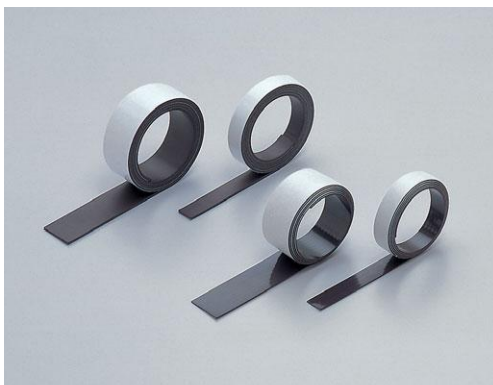

• Easy to cut length.  
• Easy to apply with glue.

Item Code	Item Name	Material	W	t	Magnetic Force	Weight	Box
140-059-474	KMS-1-1000	CPE / Ferrite	13	0.8	0.59N/cm <sup>2</sup>	60gf/cm <sup>2</sup>	42g
140-059-475	KMS-2-1000		19.1	0.8	0.59N/cm <sup>2</sup>	60gf/cm <sup>2</sup>	62g
140-059-476	KMS-3-1000		25.4	0.8	0.59N/cm <sup>2</sup>	60gf/cm <sup>2</sup>	83g
140-059-453	KMS-4-1000		12.7	1.5	0.93N/cm <sup>2</sup>	95gf/cm <sup>2</sup>	73g
140-059-492	KMS-5-1000		19.1	1.5	0.93N/cm <sup>2</sup>	95gf/cm <sup>2</sup>	110g
140-059-493	KMS-6-1000		25.4	1.5	0.93N/cm <sup>2</sup>	95gf/cm <sup>2</sup>	146g

## COUNTERPLATE



## W SERIES

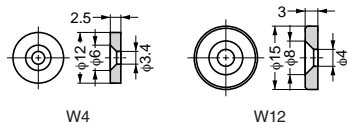

Item Code	Item Name	T	D	d1	d2	Material	Finish	Weight	Box	Carton
140-050-051	W4	2.5	12	6	3	Steel	Zinc Chromate	1.7g	1,000pcs	10,000pcs
140-050-113	W12	3	15	8	4	Steel	Nickel	3.3g	600pcs	3,000pcs

## STAINLESS STEEL COUNTERPLATE



## AS-68

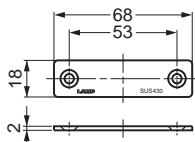

- Special plate for MC-JM magnetic catches.
- 430 stainless steel provides corrosion resistance.

Item Code	Item Name	Material	Finish	Weight
140-050-138	AS-68	Stainless Steel (SUS430)	Polished	17g

## STAINLESS STEEL COUNTERPLATE



## MC-JM49

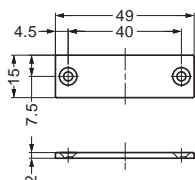

- Special plate for MC-JM magnetic catches.
- Similar to 304 stainless steel, ideal for applications where rust is an issue.
- High corrosion resistant.

Item Code	Item Name	Material	Finish	Weight	Box	Carton
140-050-149	MC-JM49	Stainless Steel	Polished	10g	100pcs	1,000pcs

## COUNTER PLATE



## SP0207

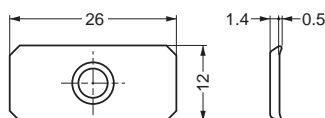

- Special plate for TC42, MC-FP5S

Item Code	Item Name	Material	Finish	Weight	Box
140-050-323	SP0207	Steel	Clear Zinc Chromate	3.1g	5,000pcs

## COUNTER PLATE



## MC-YN001U

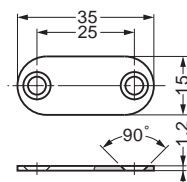

- Special plate for MC-001, MC-158, MC-159, MC-FS, MC-FP, MC-FB10

Item Code	Item Name	Material	Finish	Weight	Box
140-059-555	MC-YN001U	Steel	Nickel	4g	5,000pcs

## SPACER



## YS-P05

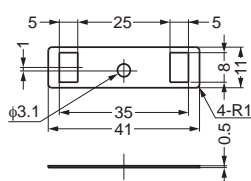

- Special plate for MC-YSW

Item Code	Item Name	Material	Color	Weight	Box
140-050-003	YS-P05	Polypropylene	Natural	0.16g	1,000pcs

# MAGNETIC TOUCH LATCH (LONG STROKE)



ML-120



- Long stroke for medium size doors.
- Push to latch / unlatch.
- Eliminates need for handles or knobs.
- Note: For overlay door, allow a 3.5mm gap between door and cabinet frame for pushing room.

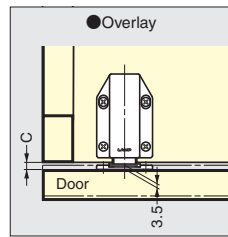
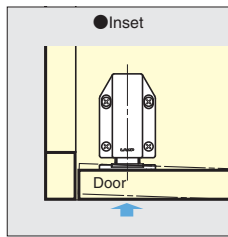
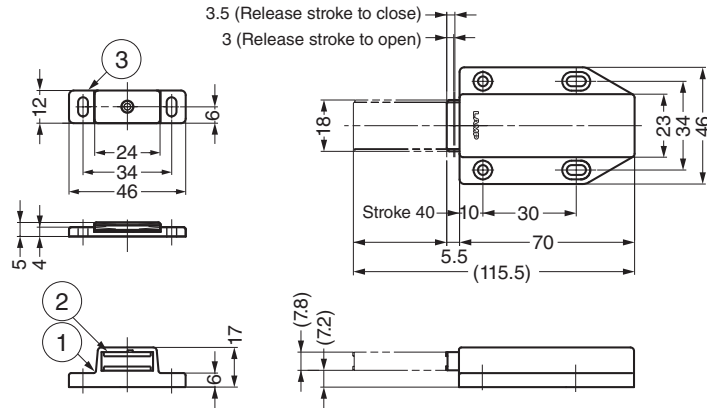

No.	Part Name	Material	Finish/Color
①	Body	ABS	Brown, White
②	Yoke	Steel	Zinc Chromate
③	Strike	Steel	Brown, White / Zinc Chromate

Item Code	Item Name	Color	Magnetic Force		Weight	Box	Carton
140-050-338	ML-120BR	Brown	23.5N	2.4kgf	53g	20pcs	240pcs
140-050-337	ML-120W	White	23.5N	2.4kgf	53g	20pcs	240pcs

# MAGNETIC TOUCH LATCH



ML-80



- Push to latch / unlatch.
- Eliminates need for handles or knobs.
- Note: For overlay door, allow a 3.5mm gap between door and cabinet frame for pushing room.

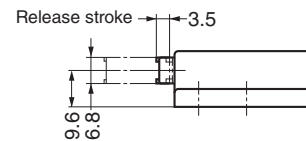
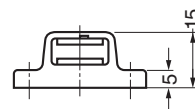
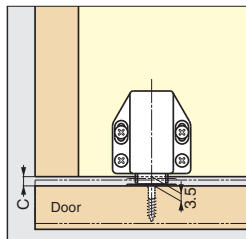
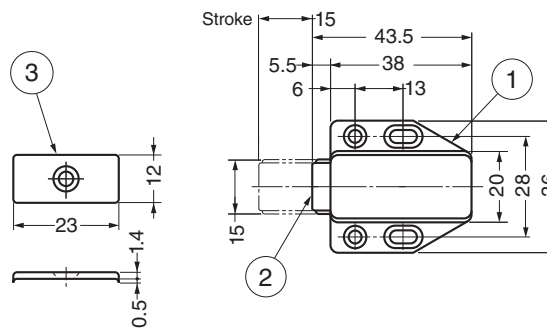

No.	Part Name	Material	Finish
①	Body	ABS	Brown, White
②	Yoke	Steel	Zinc Chromate
③	Strike	Steel	Zinc Chromate

Item Code	Item Name	Color	Magnetic Force		Weight	Box	Carton
140-050-270	ML-80BR	Brown	15.7N	1.6kgf	22g	20pcs	400pcs
140-050-271	ML-80W	White	15.7N	1.6kgf	22g	20pcs	400pcs

# MAGNETIC TOUCH LATCH



## ML-30S

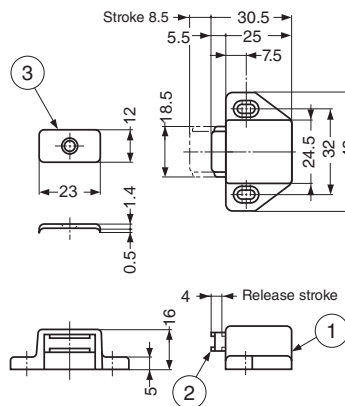

- Push to latch / unlatch.
- Eliminates need for handles or knobs.
- Note: For overlay door, allow a 4mm gap between door and cabinet frame for pushing room.

No.	Part Name	Material	Finish / Color
①	Body	ABS	Brown, White
②	Latch	Steel	Nickel
③	Strike	Steel	Nickel

Item Code	Item Name	Color	Screw	Magnetic Force	Weight	Box	Carton
140-050-054	ML-30SW	White	3	11.8N 1.2kgf	22.5g	50pcs	750pcs
140-050-055	ML-30SBR	Brown	3	11.8N 1.2kgf	22.5g	50pcs	750pcs

# MAGNETIC TOUCH LATCH



## ML-30W

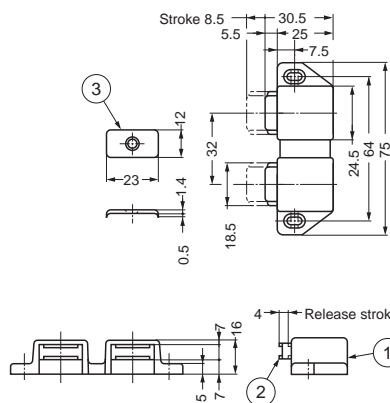

- Push to latch / unlatch.
- Eliminates need for handles or knobs.
- Double catch for dual doors that meet in the center.
- Note: For overlay door, allow a 4mm gap between door and cabinet frame for pushing room.

No.	Part Name	Material	Finish / Color
①	Body	ABS	Brown, White
②	Latch	Steel	Nickel
③	Strike	Steel	Nickel

Item Code	Item Name	Color	Screw	Magnetic Force	Weight	Box	Carton
140-050-056	ML-30WW	White	4	11.8N 1.2kgf	42g	30pcs	450pcs
140-050-057	ML-30WBR	Brown	4	11.8N 1.2kgf	42g	30pcs	450pcs

# MAGNETIC TOUCH LATCH

## MC-125

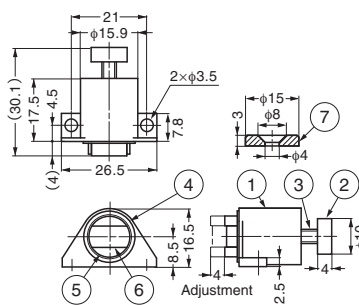

- Position adjustable : 4mm back and forward.

No.	Material	Finish / Color
①	ABS	White, Black
②	Brass	Nickel Plating
③	ABS	White, Black
④	Brass	Nickel Plating
⑤	Steel	Bright Chromate
⑥	Ferrite	-
⑦	Steel	Nickel Plating

Item Code	Item Name	Color	Magnetic Force	Weight	Box	Carton
140-021-954	MC-125WTP	White	24.5 2.5kgf	14.5g	20pcs	1,000pcs
140-021-955	MC-125BLP	Black	24.5 2.5kgf	14.5g	20pcs	1,000pcs

# MAGNETIC CATCH (W/SWITCH)



SMC

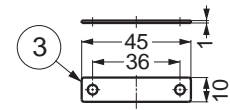
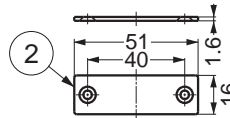
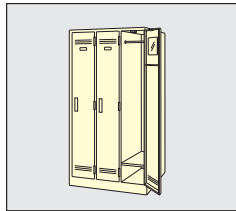
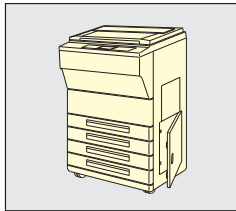
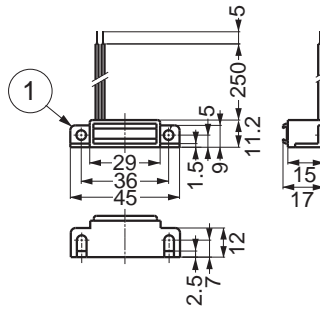
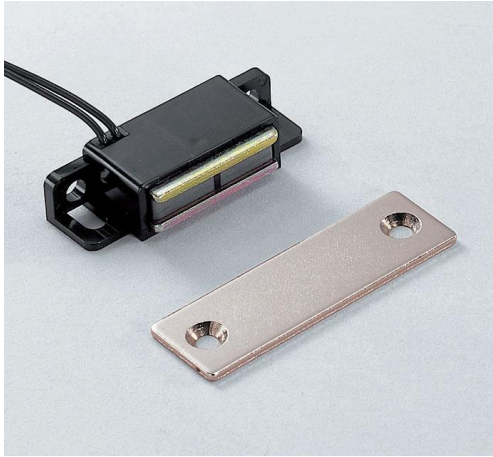

- Reed switch built-into magnetic catch allows longterm, trouble free service.
- Designed to detect when a door is closed or open.
- Use provided counter plate when stationary part is non-magnetic material. (aluminum, wood, glass etc.)
- Type A: Switch opens when counter plate and magnet are separated.
- Type B: Switch closes when counter plate and magnet are separated.
- Special design provides screw mounting options in 2 different planes.

No.	Part Name	Material	Finish/Color
①	Body	Polycarbonate	Black
②	Counterplate	Steel	Nickel
③	Backplate	Steel	Nickel

Max. Wattage	10W
Max. switching voltage	100V DC
Max. Load Rating	0.5A DC
Max. Electric Resistance	0.15Ω *1
Operating Temperature	0 ~60°C
Wire	UL3385 AWG#26 / Black
Tensile Strength(Leadwire)	1 kgf

Item Code	Item Name	Switch type	Magnetic Force		Weight	Box	Carton
140-059-416	SMC-101B	NC	9.8N	1kgf	28g	50pcs	200pcs
140-059-417	SMC-103A	NO	29.4N	3kgf	28g	50pcs	200pcs
140-059-418	SMC-103B	NC	29.4N	3kgf	28g	50pcs	200pcs

# SEALED MAGNETIC CATCH (W/SWITCH)



MC-JM74SW-30

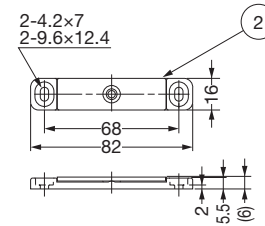
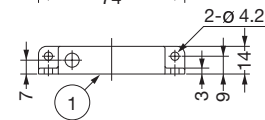
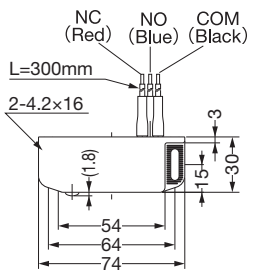
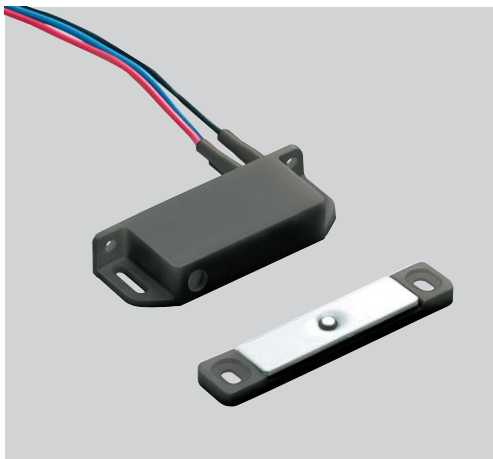

- Reed switch built-into magnetic catch allows longterm, trouble free service.
- Designed to detect when a door is closed or open.
- IP67 Water-proof.
- PSE Standard.
- Special design provides screw mounting options in 2 different planes.

No.	Part Name	Material	Finish
①	Housing	Polycarbonate	Black
②	Counterplate	SUS/Polycetal	Plain/Black
③	Magnet	Ferrite	-

Rated Voltage	AC250V5A
	AC125V5A
	DC30V5A
Insulation Resistance	MIN. 100MΩ (DC500V)
Contact Resistance	MAX. 100MΩ
Contact Rating	DC5V 16mA
Operating Temperature	-40°C~80°C, Max60%RH

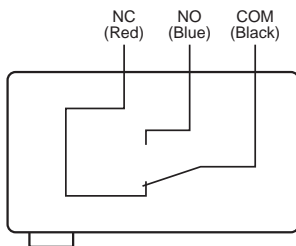

Item Code	Item Name	Magnetic Force		Weight	Box	Carton
140-017-555	MC-JM74SW-30	29.4N	3.0kgf	80g	10pcs	80pcs



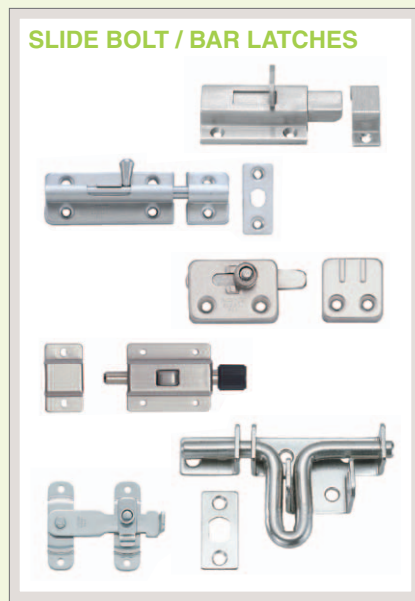

**CATCHES & LATCHES**

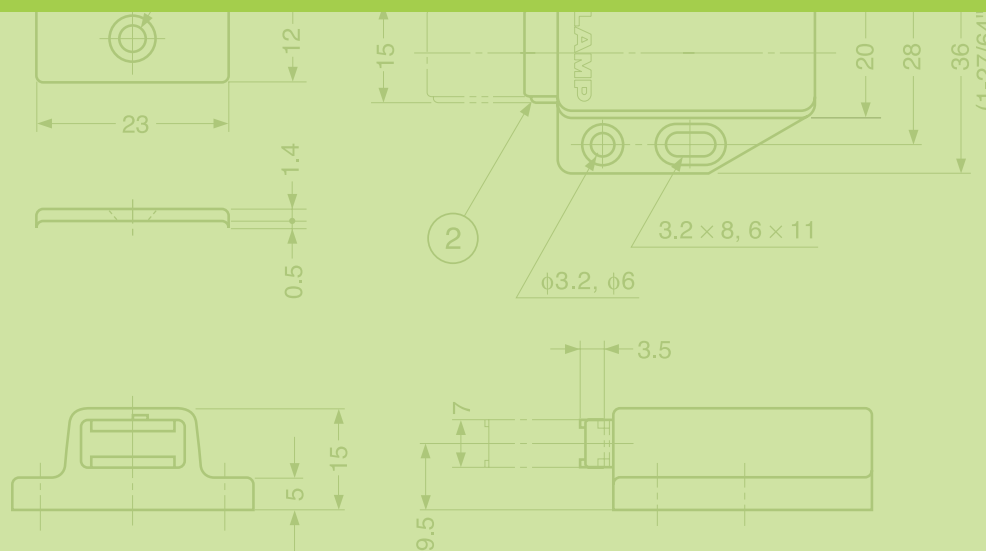

**KNUCKLE CATCHES**

Picture	Item Name	Push in / Pulling Force (kgf)	Page
	1-555-2	29 - 57 / 18 - 44	60
	NAC	3.1 / 2.7	60
	RCU	3.0 / 3.2	60
	JC-24,JC-26	2.2 - 3.1 / 1.7 - 2.7	61
	JCU	2.0 / 2.3	61
	JCU-F (SNAP-IN)	2 / 2	61
	JC-T50	3.3 / 3.8	61

**NON MAGNETIC MINI CATCHES**

Picture	Item Name	Retaining Force (kgf)	Page
	PR-21P	10	64
	PR-20P	-	64
	NS2	1	64
	PR-4PK	1.2	65
	PR-3PK	-	65
	ESN-195	3.5	65

**ROTARY/ROLLER CATCHES**

Picture	Item Name	Push in / Pulling Force (kgf)	Page
	RC6900, RC6901	1.1 - 2.2 / 1.6 - 3.2	60
	STBRC	1.0 / 2.7	63

**NON MAGNETIC CATCHES**

Picture	Item Name	Retaining Force (kgf)	Page
	MC-28	3	66
	MC-37	8	66









**BALL CATCHES**

Picture	Item Name	Push in / Pulling Force (kgf)	Page
	BCTS	2.0 - 5.7 / 1.3 - 3.9	62
	BCT	4.1 - 4.6 / 3.0 - 3.5	62
	BCU	3.6 - 4.1 / 2.4 - 3.9	63
	BCT-60W	3.2 / 2.7	63

**LEVER LATCHES**

Picture	Item Name	Retaining Force (kgf)	Page
	LL-66S	20	67
	LL-66	20	67

SLIDE / BARREL BOLTS		
Picture	Item Name	Page
	FL2	68
	FL4	68
	B-KR	69
	KR-50	69
	PRS-40	69
	KR65	70
	KR75	70
	HR35	70
	BL-40S, BL-60S	71
	BLS	71
	BL-40, BL-60	72
	BS	72
	BSS2/BSS3	73
	BSS	73
	BS-SL	74

BAR LATCHES / HASPS		
Picture	Item Name	Page
	SSG	74
	BLL	75
	BLT	75
	SSL	76
	HP-AK	76
	HP	77
	HP-635, 645, 660	77
	HP-635S, 645S, 660S	77

FASTENERS

Picture	Item Name		Page
	STF-100	<b>STAINLESS 304 STEEL</b>	78
	STF-82L	<b>STAINLESS 304 STEEL</b>	78
	STF-80	<b>STAINLESS 304 STEEL</b>	79
	STF-40	<b>STAINLESS 304 STEEL</b>	79
	CHN		79
	STF-CV150	<b>STAINLESS 316 STEEL</b>	80
	TF40C		80
	STF-C64A, B	<b>STAINLESS 304 STEEL</b>	81
	STH-C64	<b>STAINLESS 304 STEEL</b>	82
	STF-A56AH, AC	<b>STAINLESS 304 STEEL</b>	82
	SCC-60	<b>STAINLESS 304 STEEL</b>	83
	SCC-40	<b>STAINLESS 304 STEEL</b>	83
	SCC-30	<b>STAINLESS 304 STEEL</b>	83
	SCCA-60		84
	SCCA-40		84
	PS34A		84
	PS	<b>STAINLESS 304 STEEL</b>	85
	P3		85
	P3-10N		85

Picture	Item Name		Page
	P100	<b>STAINLESS 304 STEEL</b>	86
	P3-12, P3-11		86
	PS, P	<b>STAINLESS 304 STEEL</b>	86
	PS35	<b>STAINLESS 304 STEEL</b>	86
	P34		87
	P11		87
	P8		87
	P91		87
	THF-100		88
	THF-75		88
	PN-51	<b>STAINLESS 304 STEEL</b>	89
	P-1040/SS	<b>STAINLESS 304 STEEL</b>	89
	P-102H/SS	<b>STAINLESS 304 STEEL</b>	89

PUSH LOCK FASTENERS

Picture	Item Name	Retaining Force (kgf)	Page
	251F, 151F	25	90
	252F, 152F	15	91
	255F, 155F	15	92
	149 SERIES	-	93

**HANDLE LATCHES**

Picture	Item Name	Page
	LH-203	94
	WB-901503, WB-901504	96
	WB-901551, WB-901552	96

**FLUSH SLAM LATCHES**

Picture	Item Name	Page
	LC-65A	94
	LC-48	94
	WB-900418, WB-900408	95
	P10	95
	ATL-64	95
	LJ-61	96
	SX-48	98
	LC-PK32-L	98
	LC-PK32-K	99

**DAMPER CATCHES**

Picture	Item Name	Page
	DC	97

**SLIDING DOOR LATCHES**

Picture	Item Name	Page
	HC-30R	100
	HC-30	100
	HC-30H	101
	HC-70	101
	HC-70H	102
	HC-30L	102
	HC-30HL	103
	HC-65	103
	HHC-85	104
	HC-85SS	104

# ADJUSTABLE KNUCKLE CATCH



1-555-2

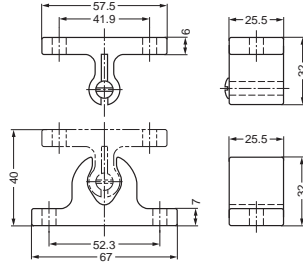

- Grabs and holds doors tightly.
- Strong catch force.
- Catch force is adjustable by turning adjustment screw.

Item Code	Item Name	Material	Color	Push in Force		Pulling Force		Weight
140-050-120	1-555-2I	Polyamide	Ivory	127.4 ~ 254.8N	13 ~ 26kgf	78.4 ~ 196N	8 ~ 20kgf	42g
140-059-516	1-555-2B	Polyamide	Black	127.4 ~ 254.8N	13 ~ 26kgf	78.4 ~ 196N	8 ~ 20kgf	42g

# KNUCKLE CATCH



NAC

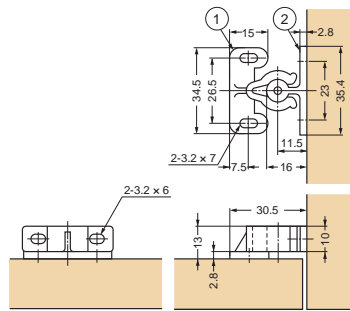

- Grabs and holds doors tightly.

### Installation

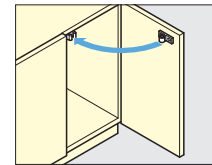

Item Code	Item Name	Push in Force		Pulling Force		Weight	Box	Carton	No.	Material	Color
140-051-013	NAC	55.8N	5.7kgf	69.5N	7.1kgf	4.5g	100pcs	1,000pcs	①	Polyacetal	Natural
									②	Polyamide	Natural

# ROTARY CATCH (MORTISE TYPE)



RCU

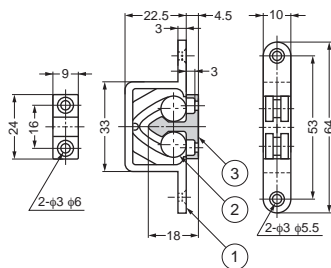

### Installation

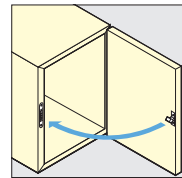

- Mortise catch for overlay doors.

No.	Material	Color
①	Polyacetal	Natural
②	Polyethylene	Natural
③	Polyacetal	Natural

Item Code	Item Name	Push in Force		Pulling Force		Weight	Box	Carton
140-051-014	RCU	29.4N	3.0kgf	31.4N	3.2kgf	8g	100pcs	800pcs

# ROTARY CATCH



RC6900, RC6901

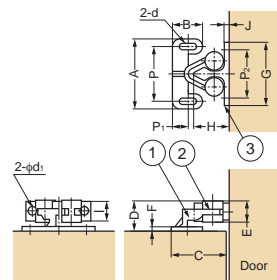

### Installation

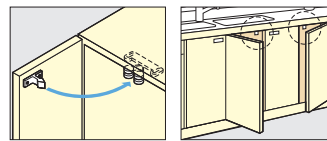

- Grabs and holds doors tightly.

No.	Material	Color
①	Polyacetal	Natural
②	Polyethylene	Natural
③	Polyacetal	Natural

Item Name	Push in Force		Pulling Force	
RC6900	10.8N	1.1kgf	15.7N	1.6kgf
RC6901	21.6N	2.2kgf	31.4N	3.2kgf

Item Code	Item Name	A	B	C	D	E	F	P	P <sub>1</sub>	G	H	I	J	P <sub>2</sub>	d	d <sub>1</sub>	Weight	Box	Carton
140-050-209	RC6900	29	12	21.2	11.3	8	2	21.5	6	26	13.5	7.5	1.7	20	3.1x7	3	3g	100pcs	2,000pcs
140-051-015	RC6901	31.3	14	27.2	12.6	9	2.3	24.4	7.5	32	16.5	9	2	23.6	3.1x7	3.1	4g	100pcs	2,000pcs

# KNUCKLE CATCH



## JC-24, JC-26

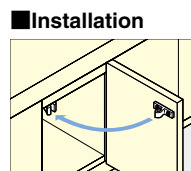
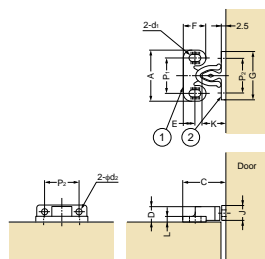

- Grabs and holds doors tightly.

No.	Part Name	Material	Color
①	Catch	Polyacetal	Natural/Black
②	Strike	Polyamide	Natural/Black

Item Code	Item Name	A	P <sub>1</sub>	C	D	E	F	G	P <sub>2</sub>	J	K	L	d <sub>1</sub>	d <sub>2</sub>	Push in Force	Pushing Force	Weight	Box	Carton		
140-050-046	JC-24	24	17	21.5	7.5	7	12	22	15.5	7.5	12.5	2	2.5x5.5	2.5	30.4N	3.1kgf	26.5N	2.7kgf	1.5g	100pcs	2,000pcs
140-916-119	JC-24B	24	17	21.5	7.5	7	12	22	15.5	7.5	12.5	2	2.5x5.5	2.5	30.4N	3.1kgf	26.5N	2.7kgf	1.5g	100pcs	2,000pcs
140-051-018	JC-26	26	18	21.5	7.5	6	12	24.5	17	7.5	12.5	2.5	3.3x6	3.3	21.6N	2.2kgf	16.7N	1.7kgf	2g	100pcs	5,000pcs

# KNUCKLE CATCH (MORTISE TYPE)



## JCU

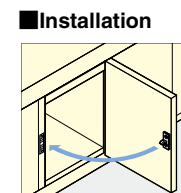
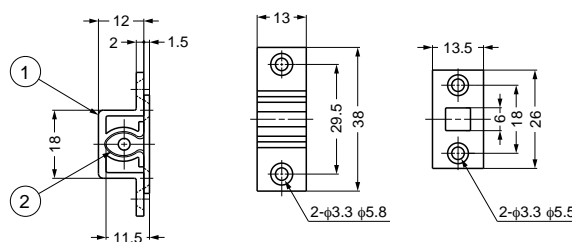

- Mortise catch for overlay doors.

Item Code	Item Name	Push in Force	Pulling Force	Weight	Box	Carton	No.	Part Name	Material	Color		
140-051-020	JCU	19.6N	2.0kgf	22.5N	2.3kgf	3.5g	50pcs	1,000pcs	①	Catch	Polyacetal	Natural
									②	Strike	Polyamide	Natural

# SNAP-IN KNUCKLE CATCH



## JCU-F

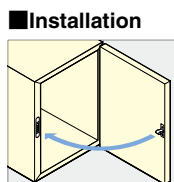
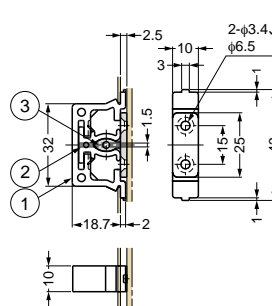

- Grabs and holds doors tightly.
- Snap-in type body for easy installation.
- Designed for sheet metal or plastic panel applications.
- Internal catch body slides 1.5mm for better alignment.

No.	Material	Color
①	Polyacetal	Natural
②	Polyacetal	Natural
③	Polyamide	Natural

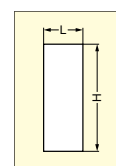

Sheet metal thickness	L	H
0.8mm	10.3mm	32.3mm
1.0mm	10.3mm	32.9mm
1.2mm	10.3mm	33.8mm

Item Code	Item Name	Push in Force	Pulling Force	Weight	Box	Carton		
140-051-112	JCU-F	19.6N	2.0kgf	19.6N	2.0kgf	5.2g	40pcs	800pcs

# KNUCKLE CATCH

## JC-T50

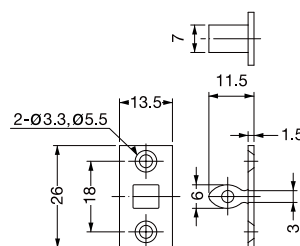
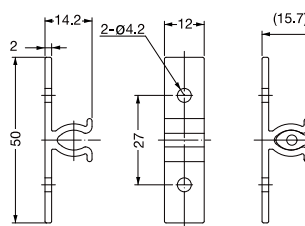

Item Code	Item Name	Push in Force	Pulling Force	Weight	Box	Carton	Part Name	Material	Color
140-019-545	JC-T50	3.3kgf	3.8kgf	9g	50pcs	500pcs	Catch	Polyacetal	White
							Strike	Polyamide	Natural White

# STAINLESS STEEL TENSION CATCH



# BCTS

- 316 stainless steel catch for harsh environments.
- Catch force is not adjustable.

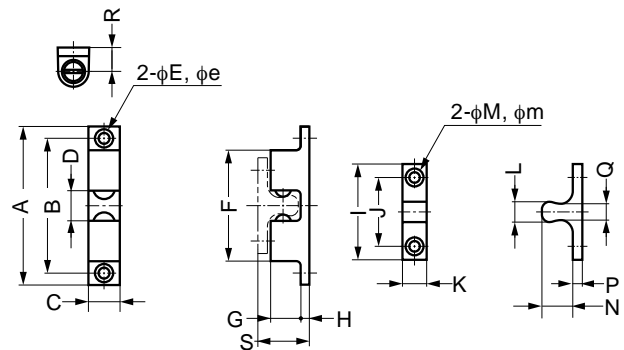

Item Code	Item Name	Push in Force		Pulling Force		Weight	Box	Carton
140-050-242	BCTS-40	20N	2kgf	13N	1.3kgf	18g	50pcs	500pcs
140-050-241	BCTS-50	23N	2.3kgf	18N	1.8kgf	30g	50pcs	500pcs
140-050-240	BCTS-70	56N	5.7kgf	38N	3.9kgf	83g	25pcs	250pcs

Material	Finish
Stainless Steel(SCS14)	Polished

\*SCC14 is similar to SUS316

Item Name	A	B	C	D	E	e	F	G	H	I	J	K	L	M	m	N	P	Q	R	S
BCTS-40	43	35	8	5.9	3.2	6.2	28.4	7.5	2.5	25	16	7.5	4.5	3.2	6.2	8.5	2.5	2.7	6	13.5
BCTS-50	50	40	10	7.5	4.2	8.2	31.5	9.3	2.9	30	20	9	6	4.2	8.2	10.3	2.9	3.8	7.2	16.1
BCTS-70	70	60	13	13	4.2	8.2	51	13	4	42	30	10.5	10	4.2	8.2	15	4	8	10.5	23

# TENSION CATCH



# BCT

- Catch force is not adjustable.

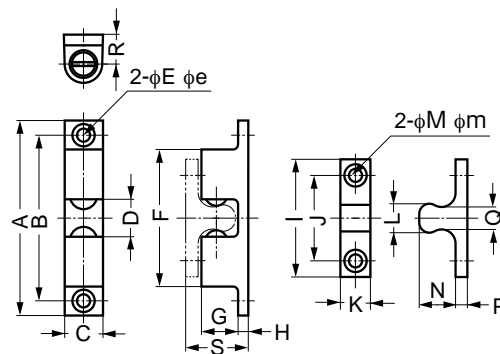
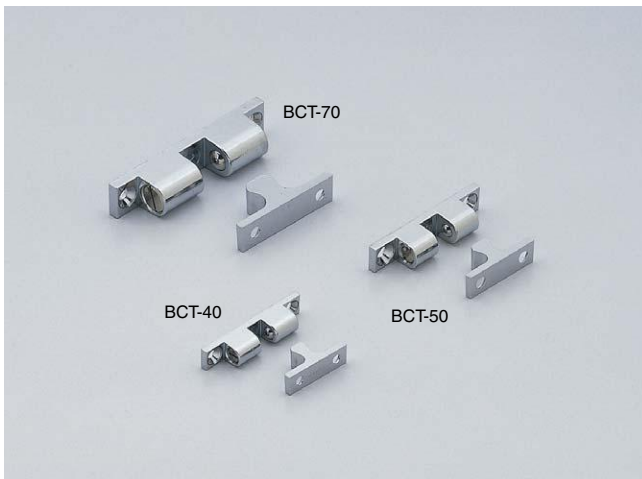

Item Code	Item Name	Push in Force		Pulling Force		Material	Finish	Weight	Box	Carton
140-050-108	BCT-40	43.1N	4.4kgf	29.4N	3.0kgf	Zinc Alloy	Chrome	16g	100pcs	400pcs
140-050-107	BCT-50	40.2N	4.1kgf	32.3N	3.3kgf	Zinc Alloy	Chrome	26g	100pcs	400pcs
140-050-106	BCT-70	45.1N	4.6kgf	34.3N	3.5kgf	Zinc Alloy	Chrome	70g	50pcs	200pcs

Item Name	A	B	C	D	E	e	F	G	H	I	J	K	L	M	m	N	P	Q	R	S
BCT-40	42.5	35	8	6.3	3.2	6.2	26.7	7.5	2.5	25	16	7.5	5.5	3.2	6.2	8.8	2.5	3.7	6.5	14
BCT-50	50	40	10	8.4	4.2	8.2	29.8	9.5	3	30	20	9	7.3	4.2	8.2	9.8	2.5	4.7	7.4	16
BCT-70	70	60	13.5	12	4.2	8.2	49	13	4	42	30	10.5	11	4.2	8.2	14.2	3	8.2	11	21.2



## TENSION CATCH



BCU

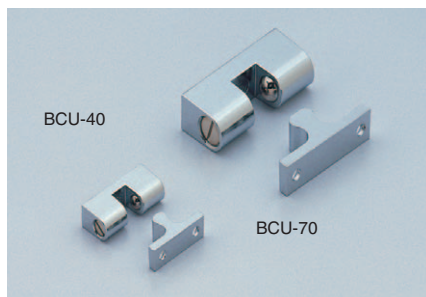

• Catch force is not adjustable.

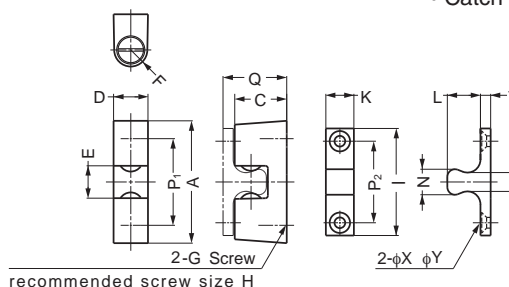

Item Code	Item Name	Push in Force		Pulling Force		Material	Finish	Weight	Box	Carton
140-050-103	BCU-40	35.3N	3.6kgf	23.5N	2.4kgf	Zinc Alloy	Chrome	18g	100pcs	400pcs
140-050-104	BCU-70	40.2N	4.1kgf	38.2N	3.9kgf	Zinc Alloy	Chrome	75g	50pcs	200pcs

Item Name	A	P <sub>1</sub>	C	D	E	F	G	H	I	P <sub>2</sub>	K	L	N	P	T	X	Y	Q
BCU-40	28.5	20	12.5	8.3	6.5	R4	M3	5	24	16	8	9	5	3	3	3.2	6.2	15.7
BCU-70	48	34	20.5	13.5	12.7	R6.5	M5	6	42	32	11	13	10	7.3	4	4.2	8.2	24.9

## TENSION CATCH



BCT-60W



• Double catch for dual doors that meet in the center.

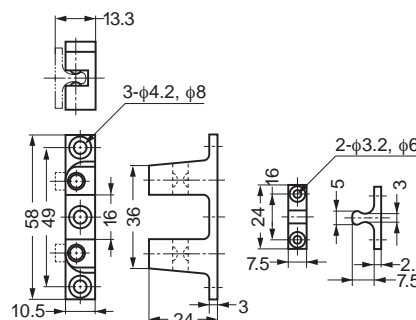

Item Code	Item Name	Push in Force		Pulling Force		Material	Finish	Weight	Box	Carton
140-059-035	BCT-60W	31.4N	3.2kgf	26.5N	2.7kgf	Zinc Alloy	Chrome	39.5g	80pcs	320pcs

## STAINLESS STEEL ROLLER CATCH



STBRC

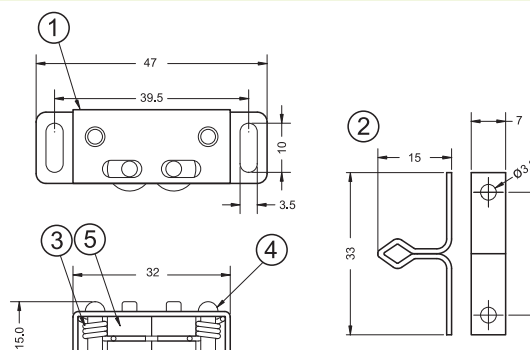
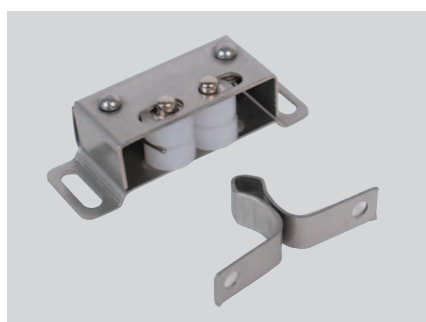

No.	Part Name	Material	Finish
①	Body	304 Stainless Steel	Plain
②	Strike		
③	Spring	430 Stainless Steel	White
④	Rivet		
⑤	Roller	Polyethylene	

Item Code	Item Name	Push in Force		Pulling Force		Weight	Box	Carton
140-098-005	STBRC	1.0kgf		2.7kgf		18g	60pcs	1,200pcs

## NON-MAGNETIC TOUCH LATCH



## PR-21P

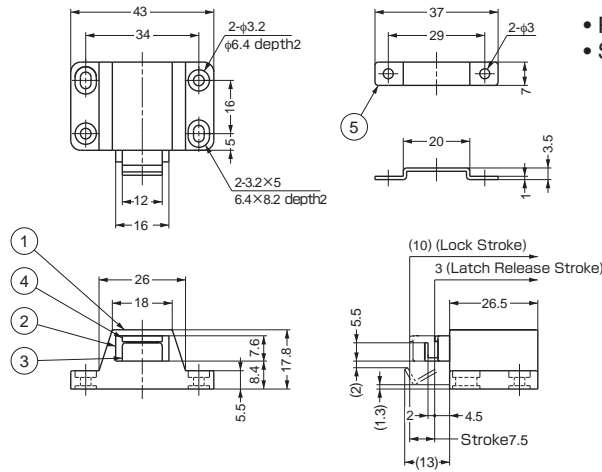
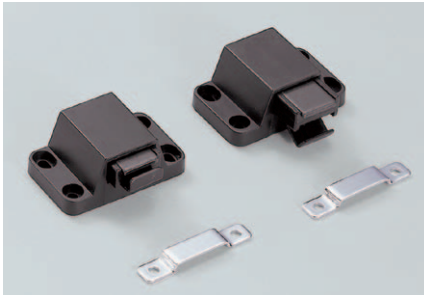

- Push to latch / unlatch.
- Strong retaining force.

No.	Part Name	Material	Finish/Color
①	Body	ABS	Black, Brown
②	Slide	Polyacetal	Black, Brown
③	Arm	Steel	Paint/Brown
④	Yoke	Steel	GB
⑤	Strike	Steel	Chrome

Item Code	Item Name	Color	Weight	Box	Carton
140-050-277	PR-21PK	Black	16.3g	100pcs	800pcs
140-050-272	PR-21PD	Brown	16.3g	100pcs	800pcs

## NON-MAGNETIC TOUCH LATCH



## PR-20P

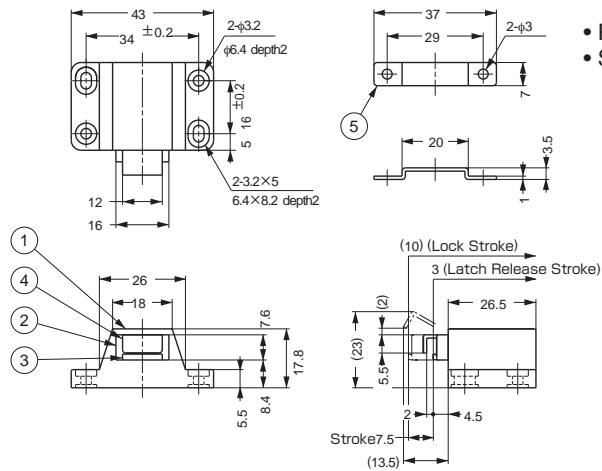

- Push to latch / unlatch.
- Strong retaining force.

No.	Part Name	Material	Finish/Color
①	Body	ABS Plastic	Black, Brown
②	Slide	Polyacetal	Black, Brown
③	Arm	Steel	Paint/Brown
④	Yoke	Steel	Bronze
⑤	Strike	Steel	Chrome

Item Code	Item Name	Color	Weight	Box	Carton
140-050-276	PR-20PK	Black	16.3g	100pcs	800pcs
140-050-274	PR-20PD	Brown	16.3g	100pcs	800pcs

## NON-MAGNETIC MINI TOUCH LATCH



## NS2

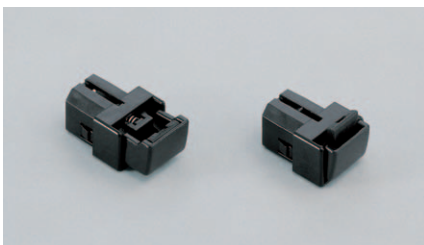

- Push to latch / unlatch.
- Miniature design is ideal for small applications.

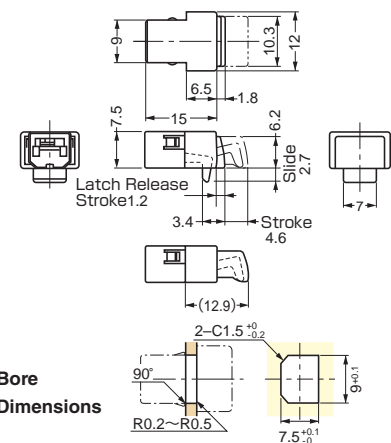
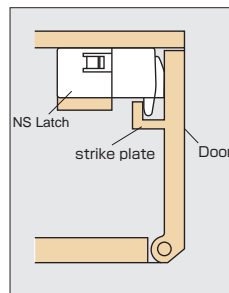
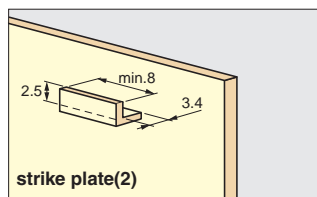
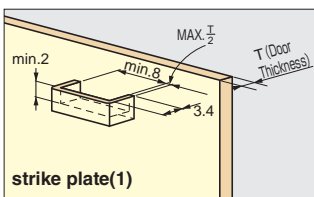

Item Code	Item Name	Material	Door Thickness	Color	Weight	Box
140-059-098	NS2	Polycarbonate	2	Black	1.1g	500pcs

# NON-MAGNETIC MINI TOUCH LATCH



## PR4PK

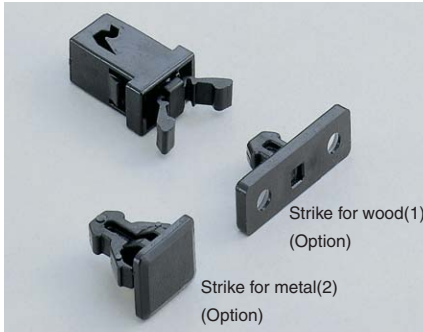

### Strike plates

Item Code	Item Name	Material
140-059-019	PR4PK-1	Polyacetal
140-059-018	PR4PK-2	Polyacetal

### Body

Item Code	Item Name	Retaining Force	Door Thickness	Weight	Box	
140-050-118	PR4PK-B	12N	1.2kgf	2	0.7g	1,000pcs

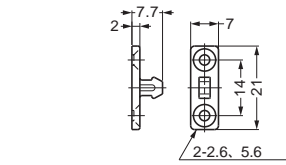

Strike for wood(1)

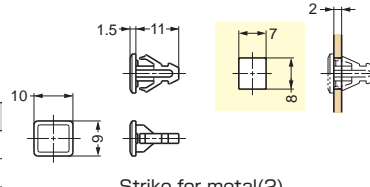

Strike for metal(2)

- Push to latch / unlatch.
- Miniature design is ideal for small applications.
- Strike sold separately.

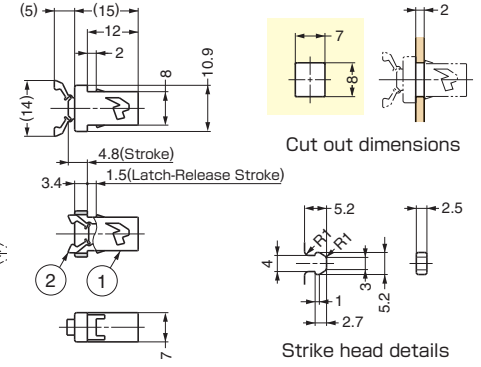

No.	Part Name	Material	Color
①	Body	Polyacetal	Black
②	Arms	Polyamide	Black

# NON-MAGNETIC TOUCH LATCH



## PR3PK



- Push to latch / unlatch.
- Thin design is ideal for tight spaces.

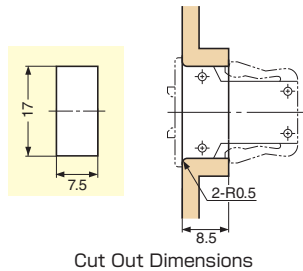

Cut Out Dimensions

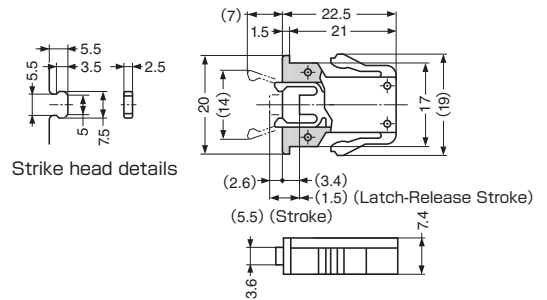

Strike head details

Item Code	Item Name	Material	Color	Weight	Box
140-050-239	PR3PK	ABS	Black	2.5g	400pcs

# NON-MAGNETIC MINI TOUCH LATCH



## ESN-195



### Strike plate

Item Code	Item Name	Material
140-014-075	ESN-195-1	Polyacetal

Item Code	Item Name	Retaining Force	Weight	Box
140-059-195	ESN-195	3.5kgf	2.3g	5,000pcs

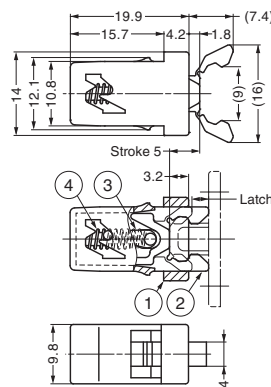

- Push to latch / unlatch.
- Strong retaining force.
- Miniature design is ideal for small applications.
- Strike sold separately.

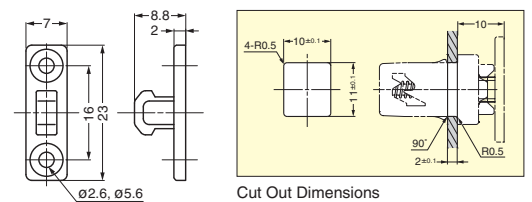

Cut Out Dimensions

No.	Part Name	Material	Finish/Color
①	Body	Polyacetal	Black
②	Catch	Polyamide	
③	Arm	EVOH	
④	Spring	Steel	-

# NON-MAGNETIC TOUCH LATCH



## MC-28



- Push to latch / unlatch.
- Touch latch with floating strike allows for easy alignment.
- Note: For overlay door, allow 3mm gap between door and cabinet frame for push space. Pulling door with excessive force without unlatching the unit may damage the mechanism. Constant loading of over 3kgf or excessive pushing or pulling is not recommended.

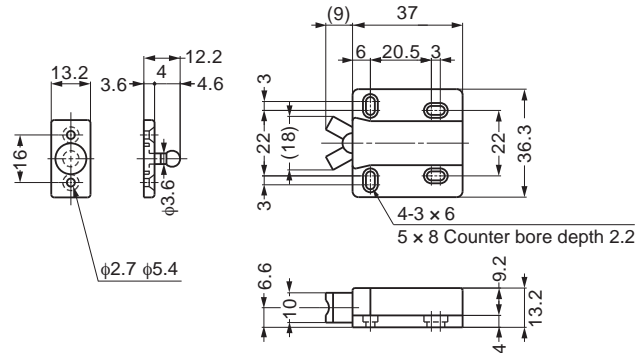

Item Code	Item Name	Material	Color	Retaining Force	Weight	Box	Carton
140-059-203	MC-28	ABS	Black	29N 3kgf	15g	50pcs	500pcs

# NON-MAGNETIC TOUCH LATCH



## MC-37F

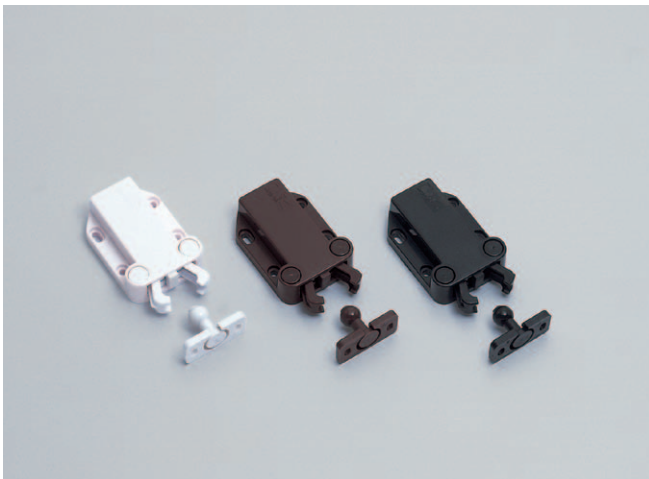

- Push to latch / unlatch.
- Strong Retaining Force.
- Floating strike allows for easy alignment.
- Note : For overlay door, allow 3mm gap between door and cabinet frame for push space. Pulling the door with excessive force without unlatching the unit may damage the mechanism. Constant loading of over 4kgf or excessive pushing or pulling is not recommended.

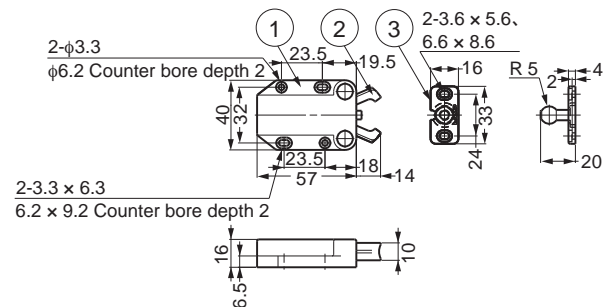
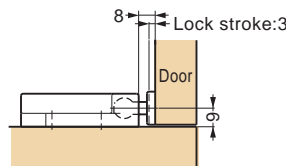

No.	Part Name	Material	Color
①	Body	ABS	Black, Brown, White
②	Arm	Polyacetal	Black, Brown, White
③	Strike	Polyamide	Black, Brown, White

Item Code	Item Name	Color	Retaining Force	Weight	Box	Carton
140-058-064	MC-37F-BK	Black	78N 8kgf	24g	30pcs	300pcs
140-058-066	MC-37F-BR	Brown	78N 8kgf	24g	30pcs	300pcs
140-058-065	MC-37F-WH	White	78N 8kgf	24g	30pcs	300pcs

# STAINLESS STEEL LEVER LATCH



## LL-66S



- Latch designed to be used on a door without knobs or handles.
- 316 Stainless steel construction makes it ideal for harsh and high corrosive environments.

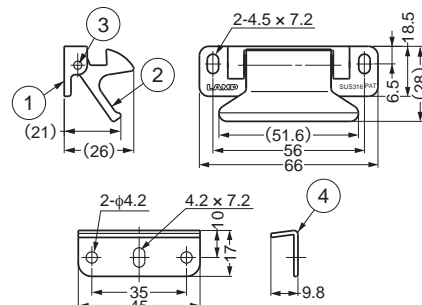

No.	Part Name	Material	Finish
①	Latch Body	Stainless Steel(SCS14)	Mirror
②	Lever	Stainless Steel(SCS14)	Mirror
③	Shaft	Stainless Steel(SUS316)	Plain
④	Strike	Stainless Steel(SUS316)	Mirror

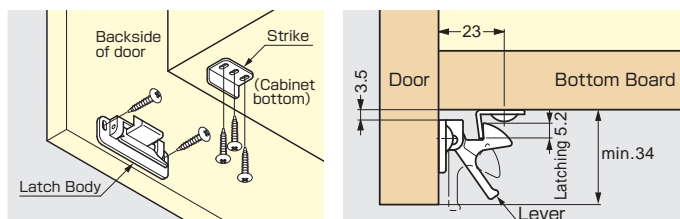

Item Code	Item Name	Material	Retaining Force	Weight	Box	Carton
140-051-030	LL-66S	Stainless Steel (SCS14)	196N 20kgf	85g	20pcs	100pcs

※SCS14 is similar to SUS316

# LEVER LATCH



## LL-66

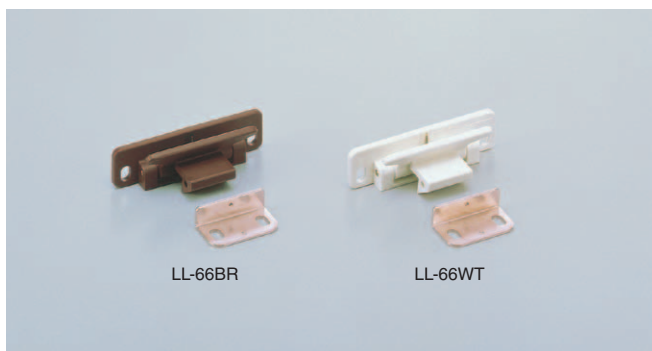

LL-66BR

LL-66WT



LL-66GR  
(Flame resistant)

- Latch designed to be used on a door without knobs or handles.
- LL-66 GR is flame resistance as per UL94V-O.

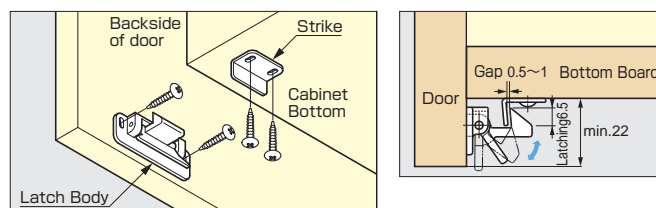
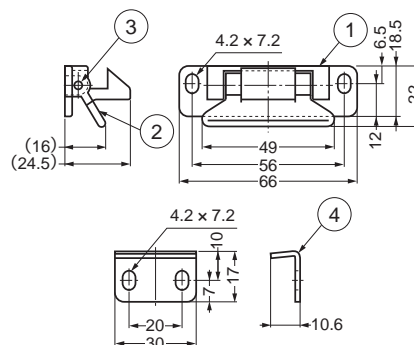

No.	Part Name	Material	Finish/Color
①	Latch Body	Polyamide	White, Brown, Gray
②	Lever	Polyamide	White, Brown, Gray
③	Shaft	Steel	Yellow Zinc Chromate
④	Strike	Steel	Nickel

Item Code	Item Name	Spec.	Color	Retaining Force	Weight	Box	Carton
140-051-028	LL-66BR	—	Brown	196N 20kgf	25g	30pcs	300pcs
140-051-027	LL-66WT	—	White	196N 20kgf	25g	30pcs	300pcs
140-051-029	LL-66GR	Flame resistant	Grey	196N 20kgf	25g	30pcs	300pcs

# SLIDE BOLT



FL2



- Flat and compact design.
- Knob will be latched in open and closed position.
- 2 different counterplates included for different mountings.

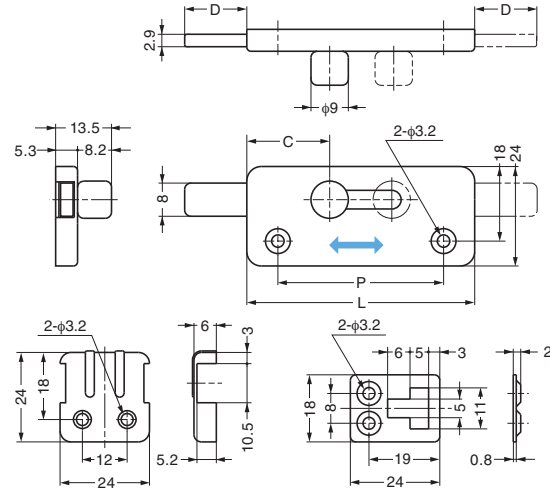

Item Code	Item Name	L	P	C	D	Material	Finish	Weight	Box	Carton
140-180-136	FL2-35	35	21	11.5	12	Stainless Steel(SUS304)	Satin	28g	30pcs	300pcs
140-180-137	FL2-55	55	40	20	15	Stainless Steel(SUS304)	Satin	39g	30pcs	300pcs

# SLIDE BOLT



FL4

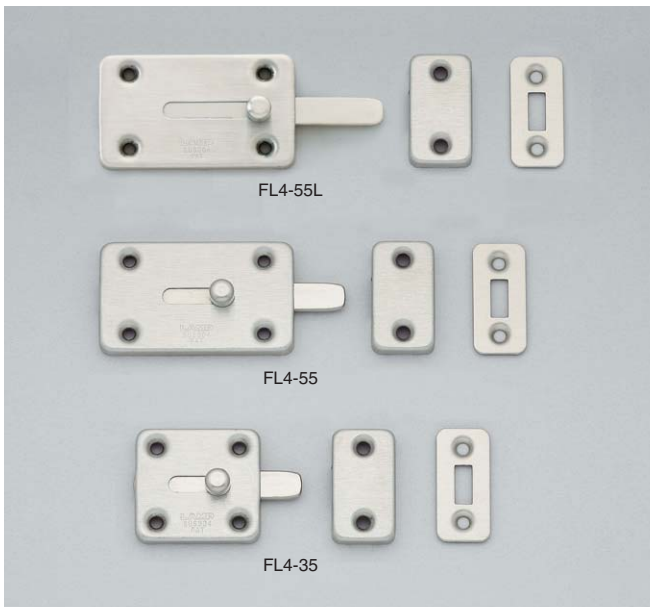

- Flat and compact design.
- Knob will be latched in open and closed position.
- 2 different counterplates included for different mountings.

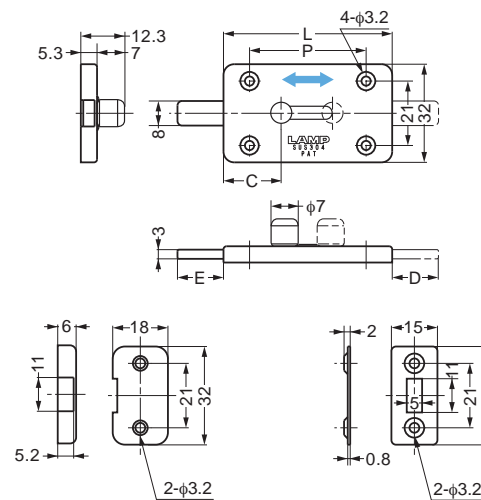

Item Code	Item Name	L	P	C	D	E	Material	Finish	Weight	Box	Carton
140-180-863	FL4-35	35	23	11.5	12	12	Stainless Steel(SUS304)	Satin	32g	30pcs	300pcs
140-180-864	FL4-55	55	38	20	15	15	Stainless Steel(SUS304)	Satin	47g	30pcs	300pcs
140-012-131	FL4-55L	55	38	20	25	15	Stainless Steel(SUS304)	Satin	47g	30pcs	300pcs

# SLIDE BOLT



## B-KR

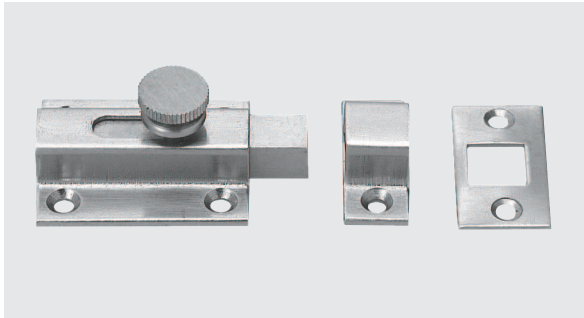

- Knurled knob provides easy grip.
- 2 counterplates included for different mountings.

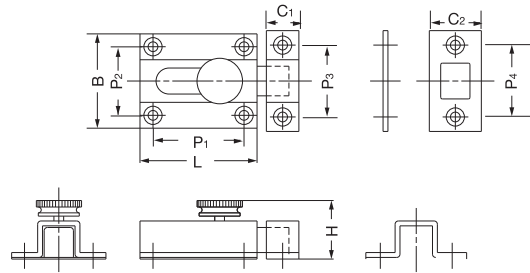

Material	Finish
Brass	Satin Nickel

Item Code	Item Name	L	B	H	C <sub>1</sub>	C <sub>2</sub>	P <sub>1</sub>	P <sub>2</sub>	P <sub>3</sub>	P <sub>4</sub>	Weight	Box	Carton
140-054-048	B-KR-35	36	29	18	11	16	26.5	19	20	21	60g	20pcs	200pcs
140-059-040	B-KR-45	45	30	18.5	12.5	17	33	20	22.5	21.5	80g	10pcs	200pcs

# SLIDE BOLT



## KR-50

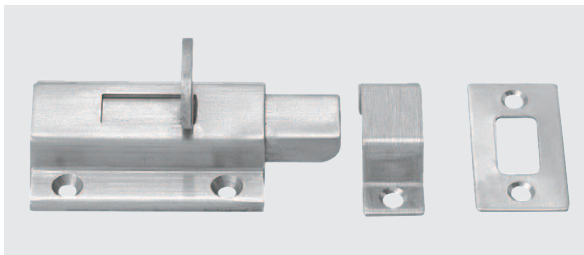

- Tab style knob provides an easy grip.
- 2 counterplates included for different mountings.

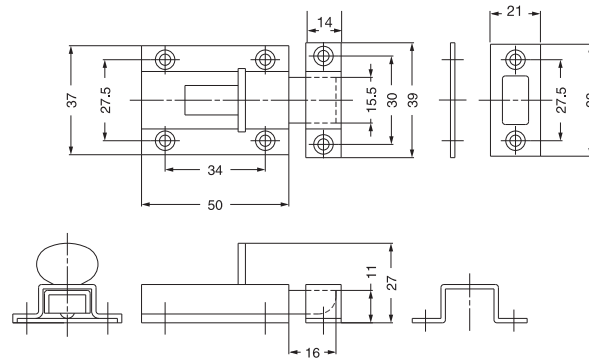

Item Code	Item Name	Weight	Box	Carton	Material	Finish
140-913-942	KR-50	80g	20pcs	200pcs	304 Stainless Steel	Satin

# PUSH BARREL BOLT



## PRS-40



- Simply push black knob to latch and push front button to release.

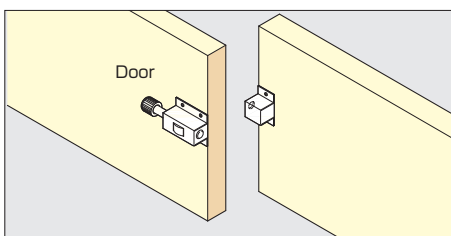
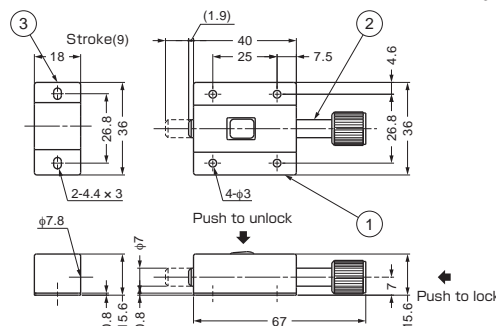

No.	Part Name	Material	Finish
①	Body	Stainless Steel(SUS304)	Satin
②	Bar	Stainless Steel(SUS303)	Satin
③	Strike	Stainless Steel(SUS304)	Satin

Item Code	Item Name	Weight
140-049-402	PRS-40	55g

# SLIDE BOLT



KR65

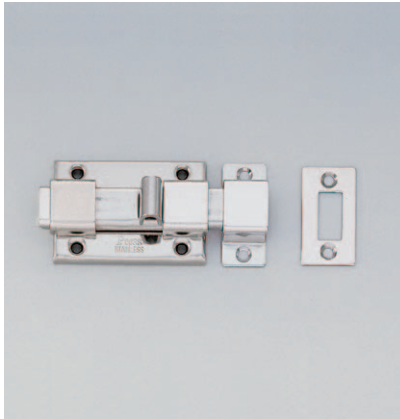

- Rounded tab prevents snagging.
- 2 counterplates included for different mountings.

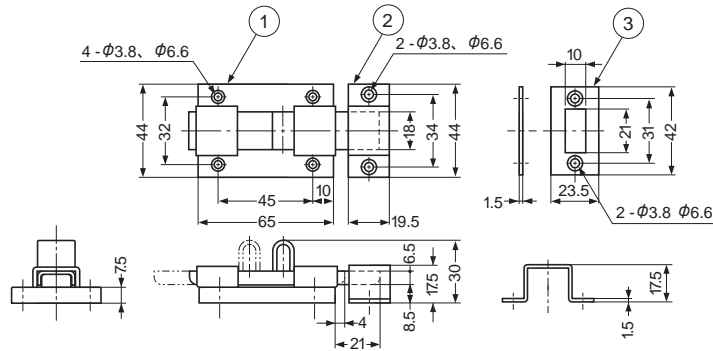

No.	Part Name	Material	Finish
①	Body	Stainless Steel(SUS304)	Polished
②	StrikeA	Stainless Steel(SUS304)	Polished
③	StrikeB	Stainless Steel(SUS304)	Polished

Item Code	Item Name	Weight	Box
140-054-050	KR65	125g	10pcs

# SLIDE BOLT



KR75



- Wing tab provides an easy grip.
- 2 counterplates included for different mountings.

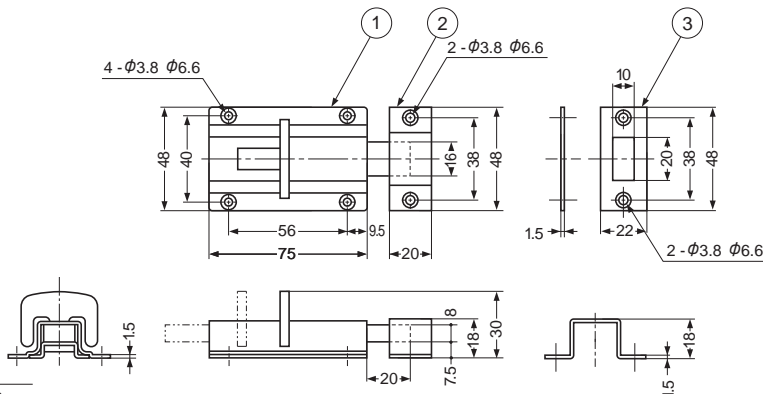

No.	Part Name	Material	Finish
①	Body	Stainless Steel(SUS304)	Satin
②	StrikeA	Stainless Steel(SUS304)	Satin
③	StrikeB	Stainless Steel(SUS304)	Satin

Item Code	Item Name	Weight	Box
140-059-042	KR75	225g	10pcs

# LEVER BOLT



HR35



- Large knob allows for easy operation.
- 2 different counterplates included for different mountings.

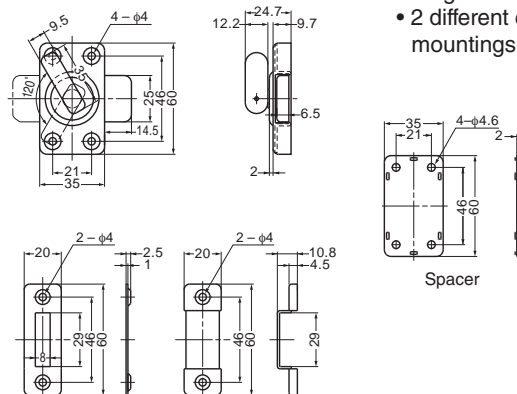

■ Spacer HR35SP-B(Optional)



Item Code	Item Name	Spec.	Material	Finish	Weight	Box	Carton
140-180-135	HR35	Latch	Stainless Steel(SUS304)	Satin	108g	10pcs	100pcs
140-180-002	HR35SP-B	Spacer	Polyamide	Black	5g	250pcs	2,500pcs



# SPRING LOADED BARREL BOLT



# BL-40S, BL-60S

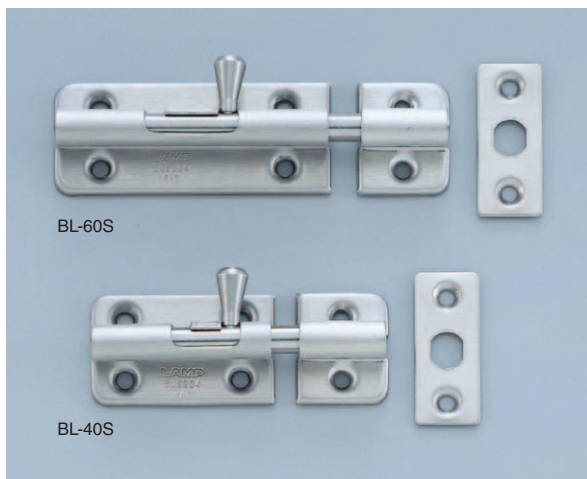

- Knob springs back into sleeve to keep bolt in locked or unlocked position.
- 2 counterplates included for different mountings.

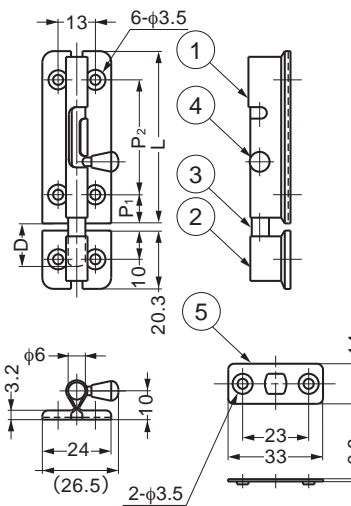

No.	Part Name	Material	Finish
①	Body	Stainless Steel(SUS304)	Satin
②	Strike	Stainless Steel(SUS304)	Satin
③	Bar	Stainless Steel(SUS303)	Plain
④	Knob	Stainless Steel(SUS303)	Plain
⑤	Strike	Stainless Steel(SUS304)	Satin

Item Code	Item Name	L	P <sub>1</sub>	P <sub>2</sub>	D	Weight	Box	Carton
140-050-245	BL-40S	40	7.5	25	11	36g	30pcs	450pcs
140-050-246	BL-60S	60	10	40	15	50g	30pcs	450pcs

# SPRING LOADED BARREL BOLT



# BLS



- Knob springs back into sleeve to keep bolt in locked or unlocked position.
- 2 counterplates included for different mountings.

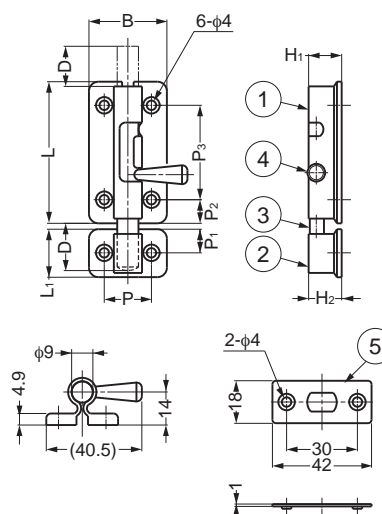

No.	Part Name	Material	Finish
①	Body	Stainless Steel(SUS304)	Satin
②	Strike	Stainless Steel(SUS304)	Satin
③	Bar	Stainless Steel(SUS303)	-
④	Knob	Stainless Steel(SUS303)	-
⑤	Strike	Stainless Steel(SUS304)	Satin

Item Code	Item Name	L	L <sub>1</sub>	H <sub>1</sub>	H <sub>2</sub>	B	P	P <sub>1</sub>	P <sub>2</sub>	P <sub>3</sub>	D	Weight	Box	Carton
140-052-000	BLS-60	60	25.4	20	20.4	33	20	12.7	10	40	17	109g	20pcs	200pcs
140-052-001	BLS-90	90	25.4	20	20.4	33	20	12.7	12.5	65	24	147g	15pcs	150pcs

# BARREL BOLT



## BL-40, BL-60

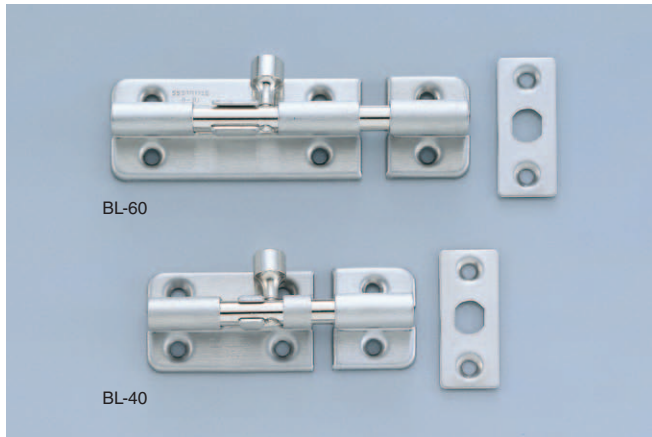

• 2 counterplates included for different mountings.

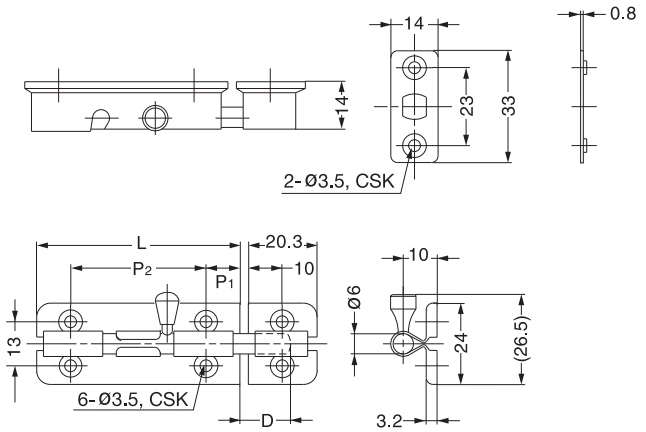

Item Code	Item Name	L	P <sub>1</sub>	P <sub>2</sub>	D	Weight	Box	Carton
140-050-247	BL-40	40	7.5	25	11	36g	30pcs	450pcs
140-051-053	BL-60	60	10	40	15	50g	30pcs	450pcs

Part Name	Material	Finish
Body and Plates	304 Stainless Steel	Satin
Bolt and Knob	Brass	Nickel

# BARREL BOLT



## BS

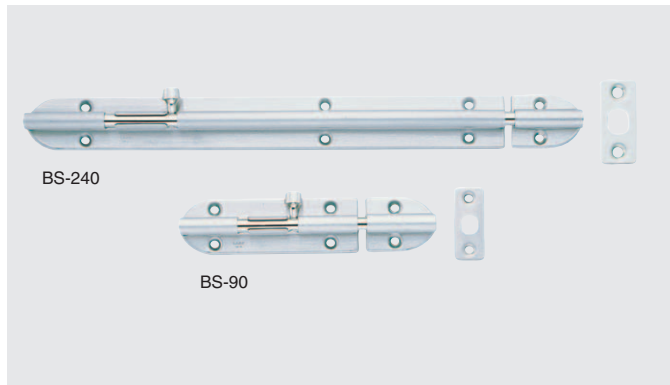

• Knob springs back into sleeve to keep bolt in locked or unlocked position.  
• 2 counterplates included for different mountings.

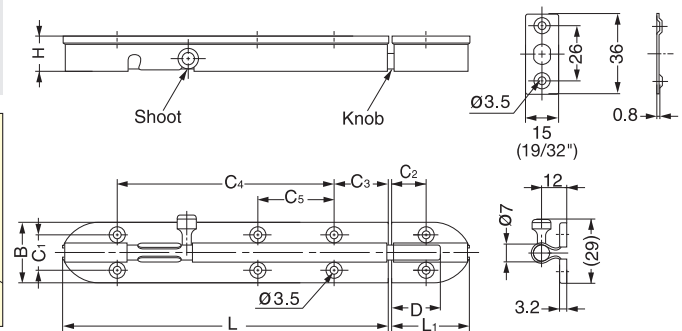
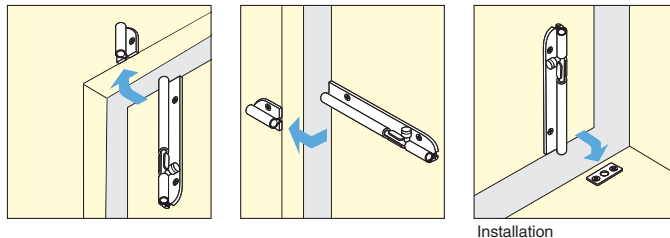

BS-240

Part Name	Material	Finish
Body and Plates	304 Stainless Steel	Satin
Bolt and Knob	Brass	Nickel

Item Code	Item Name	L	L <sub>1</sub>	H	B	C <sub>1</sub>	C <sub>2</sub>	C <sub>3</sub>	C <sub>4</sub>	C <sub>5</sub>	D	Weight	Box	Carton
140-051-050	BS-90	90	36	16.5	27	16	15	14.5	58	-	24	85g	30pcs	300pcs
140-051-051	BS-150	150	36	16.5	27	16	15	25	100	-	24	125g	20pcs	200pcs
140-051-052	BS-240	240	36	16.5	27	16	15	18.5	192	71	30	190g	10pcs	100pcs

# SPRING LOADED BARREL BOLT



## BSS2, BSS3



- Knob springs back into sleeve to keep bolt in locked or unlocked position.
- Extra sleeve for locking offers flexibility in application.
- Designed for applications where a longer throw is needed.
- 2 counterplates included for different mountings.

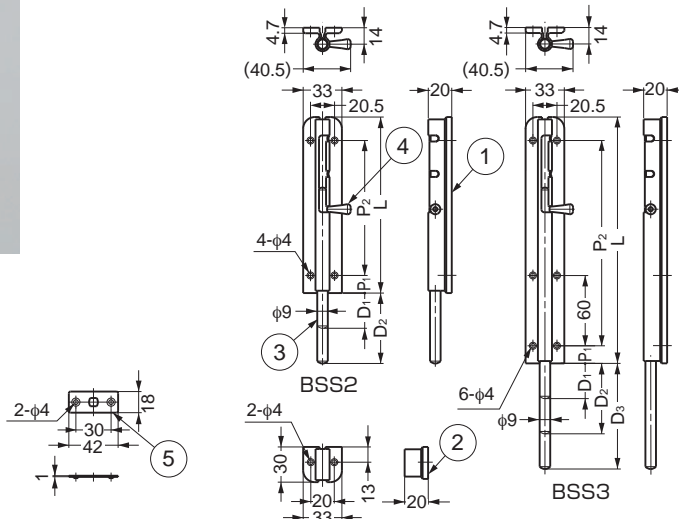

No.	Part Name	Material	Finish
①	Body	Stainless Steel(SUS304)	Satin
②	Strike	Stainless Steel(SUS304)	Satin
③	Bar	Stainless Steel(SUS303)	-
④	Knob	Stainless Steel(SUS303)	-
⑤	Strike	Stainless Steel(SUS304)	Satin

Item Code	Item Name	L	P <sub>1</sub>	P <sub>2</sub>	D <sub>1</sub>	D <sub>2</sub>	D <sub>3</sub>	Weight	Box	Carton
140-050-042	BSS2-90	90	13	60	21	42	—	140g	15pcs	150pcs
140-050-041	BSS2-150	150	15	115	30	60	—	212g	10pcs	100pcs
140-050-043	BSS3-240	240	15	205	30	60	90	320g	6pcs	60pcs

# SPRING LOADED BARREL BOLT



## BSS

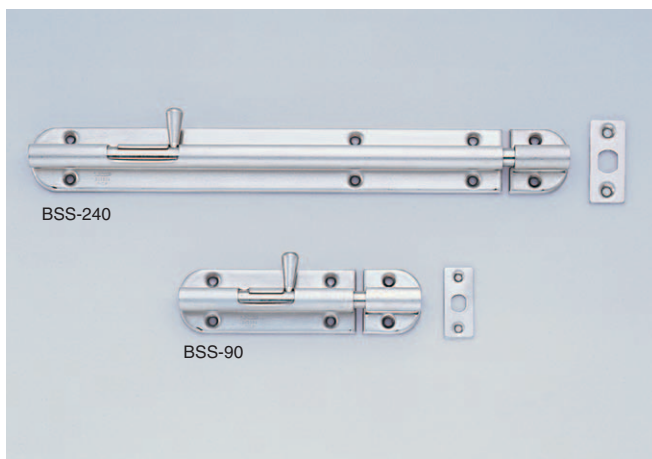

- Knob springs back into sleeve to keep bolt in locked or unlocked position.
- 2 counterplates included for different mountings.

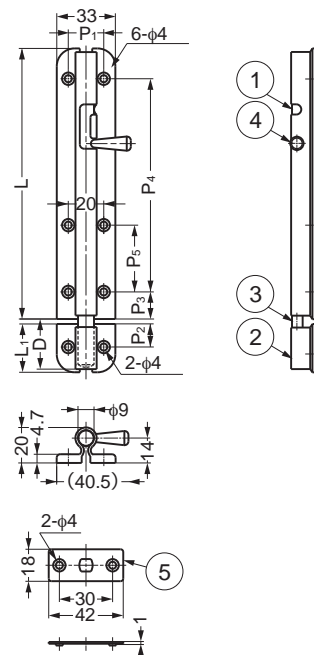

No.	Part Name	Material	Finish
①	Body	Stainless Steel(SUS304)	Satin
②	Strike	Stainless Steel(SUS304)	Satin
③	Bar	Stainless Steel(SUS303)	-
④	Knob	Stainless Steel(SUS303)	-
⑤	Strike	Stainless Steel(SUS304)	Satin

Item Code	Item Name	L	L <sub>1</sub>	P <sub>1</sub>	P <sub>2</sub>	P <sub>3</sub>	P <sub>4</sub>	P <sub>5</sub>	D	Weight	Box	Carton
140-052-002	BSS-90	90	30	20.5	13	13	60	-	24	142g	15pcs	150pcs
140-052-003	BSS-150	150	30	20.5	13	15	115	-	32	215g	10pcs	100pcs
140-052-004	BSS-240	240	30	20.5	13	15	205	60	32	330g	6pcs	60pcs

# SPRING LOADED BARREL BOLT



## BS-SL



- Weather resistance full 304 Stainless Steel construction.
- Temporary holding system for smooth locking and unlocking.
- Knob springs back into sleeve to keep bolt in locked or unlocked position.

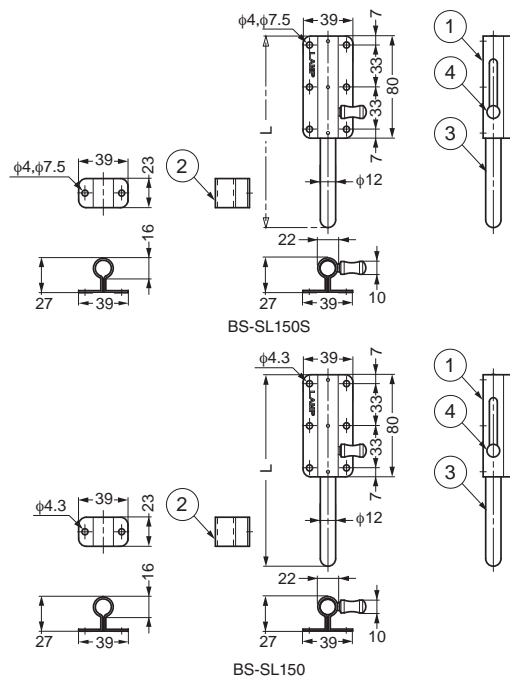

No.	Part Name	Material	Finish
①	Body	Stainless Steel(SUS304)	Satin
②	Strike	Stainless Steel(SUS304)	Satin
③	Bar	Stainless Steel(SUS303)	-
④	Knob	Stainless Steel(SUS303)	-

Item Code	Item Name	L	Box	Carton
140-022-286	BS-SL150S	150	2pcs	40pcs
140-022-287	BS-SL300S	300	2pcs	30pcs
140-022-288	BS-SL450S	450	2pcs	30pcs
140-022-283	BS-SL150	150	2pcs	40pcs
140-022-284	BS-SL300	300	2pcs	30pcs
140-022-285	BS-SL450	450	2pcs	30pcs

# GATE LATCH



## SSG



- Gate latch with holes for pad lock. (Pad lock not included.)
- Lift and drop design keeps handle out of the way when not in use.

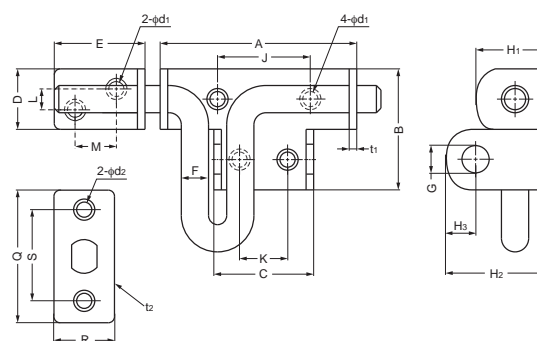

Material	Finish
Stainless Steel(SUS304)	Polished

Item Code	Item Name	A	B	C	D	E	F	G	H <sub>1</sub>	H <sub>2</sub>	H <sub>3</sub>	J	K	L	M	Q	R	S	d <sub>1</sub>	d <sub>2</sub>	t <sub>1</sub>	t <sub>2</sub>	Weight	Box	Carton
140-059-177	SSG-45	45	28	26	14	21	6	7	16	20.5	7.5	22	11	2	8	32	15	22	4.8	4.8	2.0	1.2	65g	20pcs	240pcs
140-059-178	SSG-65	65	40	33	20	29	9	10	21.5	29	10	30	14	4	14	40	18	28	5.9	5.9	2.5	1.5	175g	10pcs	100pcs
140-179-391	SSG-85	85	46	42	26	34	12	10	28	35.5	11	38	21	8	17	48	22	35	6	5.2	3.0	1.5	400g	5pcs	60pcs

# SPRING LOADED BAR LATCH



**BLL**

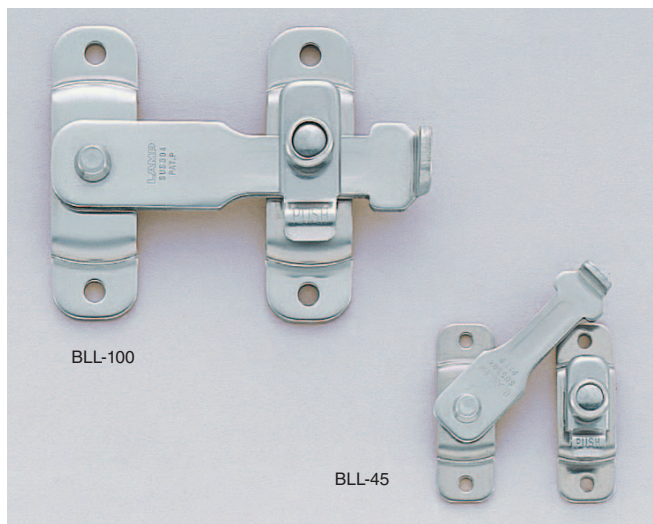

- Latch bolt snaps into the strike to prevent accidental release.
- Push tab on strike to release.

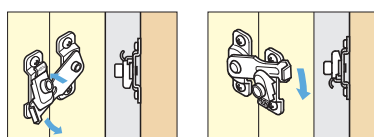
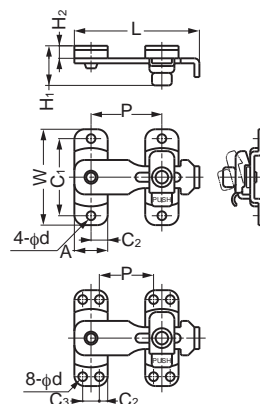

Material	Finish
Stainless Steel(SUS304)	Polished

Item Code	Item Name	L	W	A	C <sub>1</sub>	C <sub>2</sub>	C <sub>3</sub>	H <sub>1</sub>	H <sub>2</sub>	P	d	Weight	Box	Carton
140-059-073	BLL-45	48	40	13	32	6.5	-	17	4.5	23±3	3.2	28g	20pcs	400pcs
140-059-074	BLL-60	63	46	16	37	8	-	20	6	34±4	4.2	50g	20pcs	400pcs
140-059-075	BLL-80	85	65	20	53	10	-	22.5	7	47±7	5	100g	10pcs	200pcs
140-059-076	BLL-100	105	80	25	66	12.5	-	26.5	8	59±7	5.5	182g	10pcs	100pcs
140-059-183	BLL-120	127	100	28.5	80	6.75	15	28	8	56±10	5.2	270g	8pcs	80pcs
140-059-184	BLL-150	155	120	30.5	95	7.25	16	28	8	74±14	5.2	350g	6pcs	60pcs

# BAR LATCH



**BLT**



- Thick material ensures durability.
- Thumb screw on bar keeps latch closed.

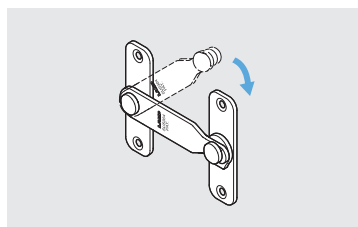
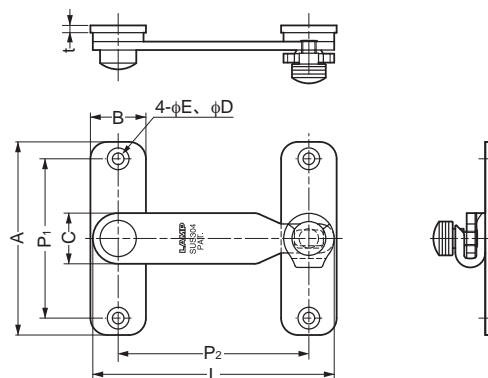

Material	Finish
Stainless Steel(SUS304)	Mirror

Item Code	Item Name	L	P <sub>1</sub>	P <sub>2</sub>	A	B	C	D	E	t	Weight	Box	Carton
140-050-252	BLT-45	45	30	33	40	14	12	3.5	6	2	31g	20pcs	400pcs
140-050-253	BLT-60	60	37	45	48	17	15	3.8	7.5	2	54g	20pcs	400pcs
140-050-254	BLT-80	80	53	62	65	21	18	4.3	8	3	95g	10pcs	200pcs
140-050-255	BLT-100	100	66	79	80	24	21	4.8	9	3	177g	10pcs	100pcs
140-050-256	BLT-120	120	73	98	90	28	24	5.1	10	4	243g	8pcs	80pcs

# BAR LATCH



- Unique slide-in bar keeps latch locked.
- Slide out and lift the bar to release.

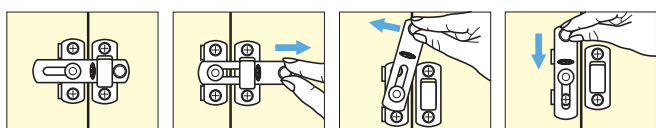
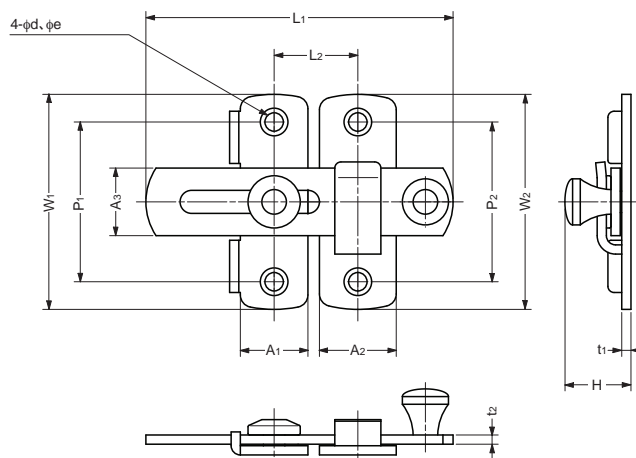

Material	Finish
Stainless Steel(SUS304)	Electro Polished

Item Code	Item Name	L <sub>1</sub>	L <sub>2</sub>	W <sub>1</sub>	W <sub>2</sub>	A <sub>1</sub>	A <sub>2</sub>	A <sub>3</sub>	P <sub>1</sub>	P <sub>2</sub>	H	t <sub>1</sub>	t <sub>2</sub>	d	e	Weight	Box	Carton
140-014-008	SSL-50	50	20±4	35	35	13	15	13	26	26	14.5	2	2	4.2	6.2	32g	10pcs	150pcs
140-014-009	SSL-70	70	28±6	50	50	18	20	18	37	37	19	2	2.5	5.2	8	68g	10pcs	150pcs
140-014-010	SSL-100	100	45±15	70	70	22	25	22	52	52	21.5	3	3	5.8	9	142g	5pcs	80pcs

# LATCH HASP



- Hasp with built-in latch.
  - Snap on the flap to keep latch closed.
  - Slide the latch knob to release.
- Flap is spring loaded in open direction.
- Plastic cap on end softens the opening sound.

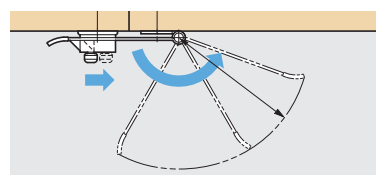
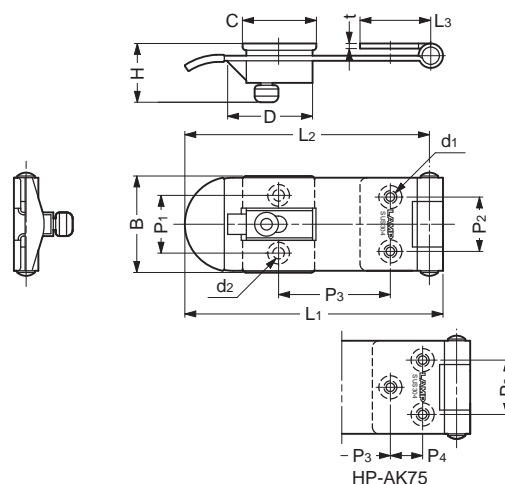

Material	Finish
Stainless Steel(SUS304)	Polished

Item Code	Item Name	L <sub>1</sub>	L <sub>2</sub>	L <sub>3</sub>	B	P <sub>1</sub>	P <sub>2</sub>	P <sub>3</sub>	P <sub>4</sub>	H	C	D	t	d <sub>1</sub>	d <sub>2</sub>	Weight	Box	Carton
140-180-801	HP-AK50	51	48	13	22.2	13.5	12	19	-	16.6	18	20.5	1.2	2-φ3	2-φ3.3	22g	25pcs	250pcs
140-180-802	HP-AK65	66	63	19	24.2	13.5	14	28	-	16.6	18	20.5	1.5	2-φ3.2	2-φ3.3	35g	20pcs	200pcs
140-180-803	HP-AK75	76	72	24.8	27.4	17	16	35	9.5	17.5	21.2	25	1.5	2-φ3.8	2-φ3.4	48g	15pcs	150pcs

# STAINLESS STEEL HASP



**HP**

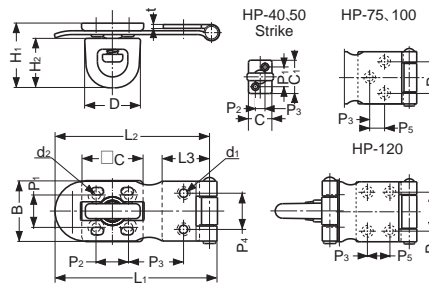

- Rotating padlock eye allows hasp to stay fastened tight without a padlock.
- Ideal for harsh and high corrosion environments.

Material	Finish
Stainless Steel (SUS304)	Polished

Item Code	Item Name	L <sub>1</sub>	L <sub>2</sub>	L <sub>3</sub>	B	P <sub>1</sub>	P <sub>2</sub>	P <sub>3</sub>	P <sub>4</sub>	P <sub>5</sub>	H <sub>1</sub>	H <sub>2</sub>	C	D	t	d <sub>1</sub>	d <sub>2</sub>	Weight	Box	Carton
140-050-224	HP40	40	37	13	22	13	6.4	10.8	12	-	22	17.9	15.3	17.7	1.2	2- $\phi$ 3	2- $\phi$ 3	21.5g	30pcs	300pcs
140-050-225	HP50	50	47	13	22.3	13	9	16	12	-	22	17.9	18.3	17.7	1.2	2- $\phi$ 3	2- $\phi$ 3	24g	25pcs	250pcs
140-050-226	HP65	65	62	19	24	13	13	21.5	14	-	24.5	20.4	24.5	22.5	1.5	2- $\phi$ 3.2	4- $\phi$ 3.2	41.5g	20pcs	200pcs
140-050-227	HP75	75	72	24.8	27	15	15	25.7	16	9.5	27.4	22	27.8	23.2	1.5	3- $\phi$ 3.8	4- $\phi$ 3.8	51.5g	15pcs	150pcs
140-050-228	HP100	100	95	30	35.5	19	19	29	21	10	32.2	27.9	35.5	31	2	3- $\phi$ 4	4- $\phi$ 4.5	118.5g	10pcs	100pcs
140-050-229	HP120	120	115	35.5	40	21	22	38	26	15	34.8	27.9	40.5	31	2.5	4- $\phi$ 5.2	4- $\phi$ 5.2	172g	8pcs	80pcs

# WELD-ON STAINLESS STEEL HASP



**HP-635, 645, 660**



- Ideal for harsh and high corrosion environments.

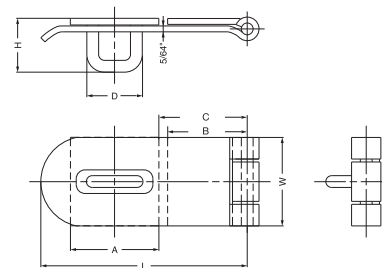

Material	Finish
Stainless Steel(SUS316)	Electro Polished

Item Code	Item Name	L	W	A	B	C	D	H	Weight	Box	Carton
140-039-602	HP-635	88.9	38.1	38.1	33.3	41.3	23.8	20.6	110g	25pcs	200pcs
140-039-601	HP-645	114.3	38.1	38.1	57.2	64.3	23.8	20.6	173g	20pcs	160pcs
140-039-600	HP-660	152.4	50.8	38.1	69.9	100.4	23.8	20.6	290g	10pcs	100pcs

# STAINLESS STEEL HASP



**HP-635S, 645S, 660S**

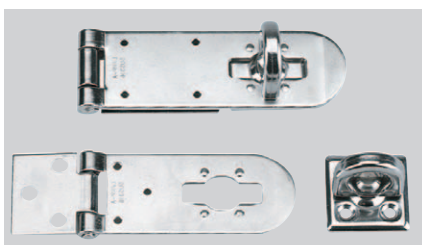

- Rotating padlock eye allows hasp to stay fastened tight without a padlock.
- Ideal for harsh and high corrosion environments.

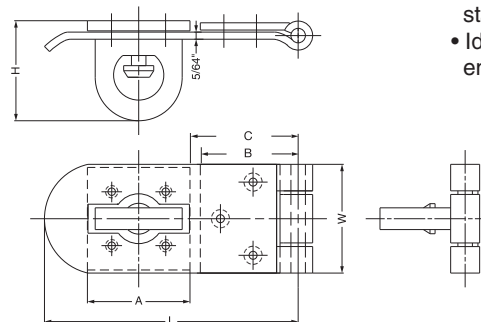

Material	Finish
Stainless Steel(SUS316)	Electro Polished

Item Code	Item Name	L	W	A	B	C	H	Weight	Box	Carton
140-039-603	HP-635S	88.9	38.1	38.1	33.3	40.5	34.9	130g	25pcs	200pcs
140-039-604	HP-645S	114.3	38.1	38.1	57.2	61.9	34.9	184g	20pcs	160pcs
140-039-605	HP-660S	152.4	50.8	38.1	69.9	98.4	34.9	302g	10pcs	100pcs

## DRAW LATCH (W/SAFETY LOCK)



## STF100



- With safety lock to prevent accidental release.
- Push safety button and lift to release.

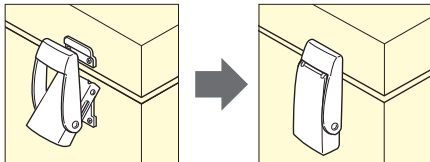
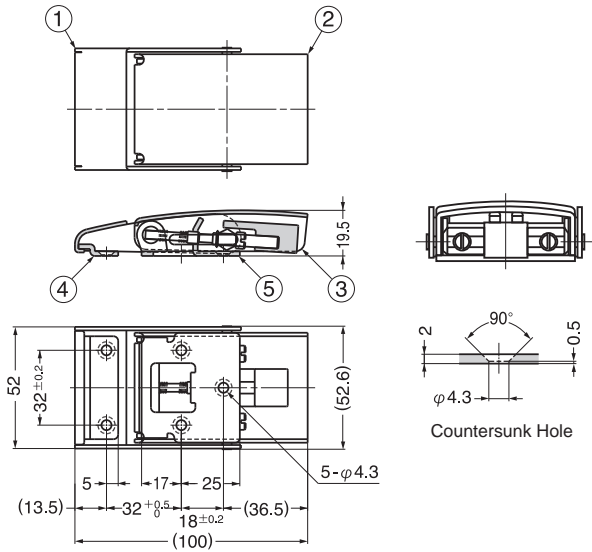

No.	Part Name	Material	Finish/Color
①	Body A	Stainless Steel(SUS304)	Satin
②	Body B	Stainless Steel(SUS304)	Satin
③	Push lever	Rubber	Black
④	Strike	Stainless Steel(SUS304)	Satin
⑤	Mounting Plate	Stainless Steel(SUS304)	Polished

Item Code	Item Name	Load Capacity	Weight	Box	Carton
120-044-024	STF100	784N 80kgf	190g	6pcs	120pcs

## DRAW LATCH (W/SAFETY LOCK)



## STF82L



- With safety lock to prevent accidental release.
- Push safety button and lift to release.

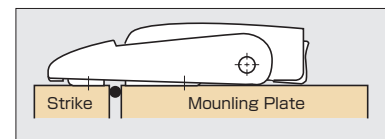
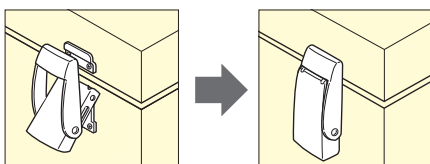
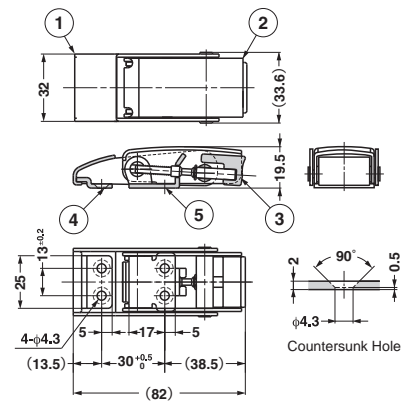

No.	Part Name	Material	Finish/Color
①	Body A	Stainless Steel(SUS304)	Satin
②	Body B	Stainless Steel(SUS304)	Satin
③	Push lever	Rubber	Black
④	Strike	Stainless Steel(SUS304)	Satin
⑤	Mounting Plate	Stainless Steel(SUS304)	Polished

Item Code	Item Name	Load Capacity	Weight	Box	Carton
120-913-101	STF82L	784N 80kgf	111g	12pcs	180pcs



# DRAW LATCH (SPRING LOADED)



# STF80

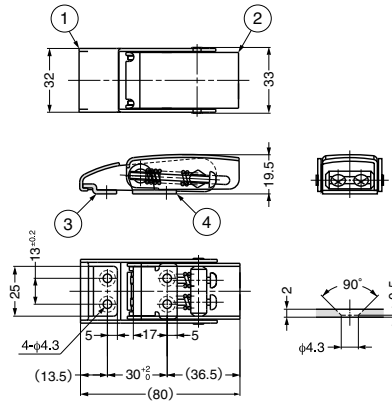

- Spring Loaded latch provides constant holding tension for secure latching.
- Durable against vibration.

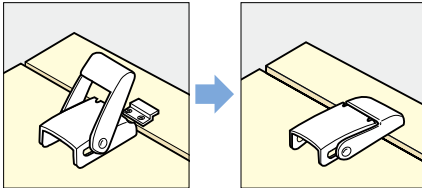

No.	Part Name	Material	Finish
①	Body A	Stainless Steel(SUS304)	Satin
②	Body B	Stainless Steel(SUS304)	Satin
③	Strike	Stainless Steel(SUS304)	Satin
④	Mounting Plate	Stainless Steel(SUS304)	Polished

Item Code	Item Name	Load Capacity	Weight	Box	Carton
120-914-490	STF80	784N	80kgf	110g	12pcs / 180pcs

# DRAW LATCH



# STF40

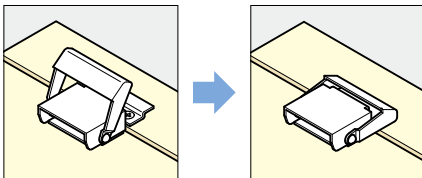
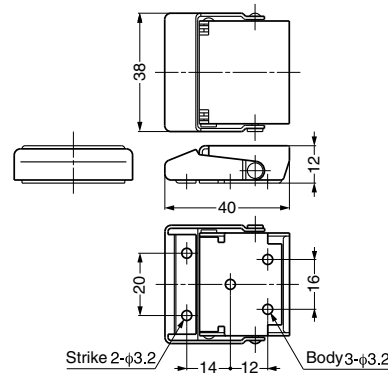

Item Code	Item Name	Material	Finish	Weight	Box	Carton
120-044-025	STF40	Stainless Steel(SUS304)	Polished	30g	30pcs	300pcs

# ADJUSTABLE DRAW LATCH

# CHN

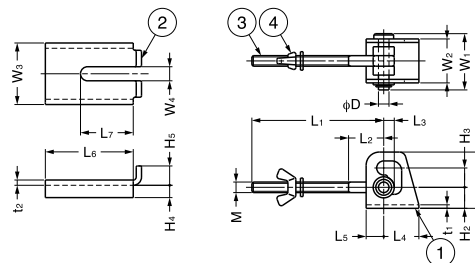

- Exposed threaded rod allows adjustment of latching distance.

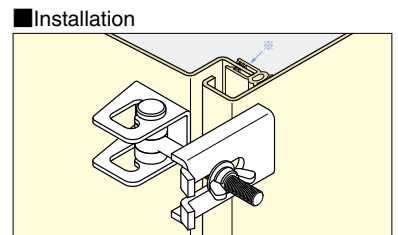

No.	Part Name	Material	Finish
①	Body	Stainless Steel(SUS304)	Bead Blasting
		Steel	Yellow Zinc Chromate
②	Counter plate	Stainless Steel(SUS304)	Bead Blasting
		Steel	Yellow Zinc Chromate
③	Bolt	Stainless Steel(SUS304)	Plain
④	Nut	Stainless Steel(SUS304)	Plain

Item Code	Item Name	Spec.	L <sub>1</sub>	L <sub>2</sub>	L <sub>3</sub>	L <sub>4</sub>	L <sub>5</sub>	L <sub>6</sub>	L <sub>7</sub>	L <sub>8</sub>	L <sub>9</sub>	L <sub>10</sub>	L <sub>11</sub>	L <sub>12</sub>	L <sub>13</sub>	L <sub>14</sub>	L <sub>15</sub>	L <sub>16</sub>	L <sub>17</sub>	L <sub>18</sub>	L <sub>19</sub>	L <sub>20</sub>	L <sub>21</sub>	L <sub>22</sub>	L <sub>23</sub>	L <sub>24</sub>	L <sub>25</sub>	L <sub>26</sub>	L <sub>27</sub>	L <sub>28</sub>	L <sub>29</sub>	L <sub>30</sub>	L <sub>31</sub>	L <sub>32</sub>	L <sub>33</sub>	L <sub>34</sub>	L <sub>35</sub>	L <sub>36</sub>	L <sub>37</sub>	L <sub>38</sub>	L <sub>39</sub>	L <sub>40</sub>	L <sub>41</sub>	L <sub>42</sub>	L <sub>43</sub>	L <sub>44</sub>	L <sub>45</sub>	L <sub>46</sub>	L <sub>47</sub>	L <sub>48</sub>	L <sub>49</sub>	L <sub>50</sub>	L <sub>51</sub>	L <sub>52</sub>	L <sub>53</sub>	L <sub>54</sub>	L <sub>55</sub>	L <sub>56</sub>	L <sub>57</sub>	L <sub>58</sub>	L <sub>59</sub>	L <sub>60</sub>	L <sub>61</sub>	L <sub>62</sub>	L <sub>63</sub>	L <sub>64</sub>	L <sub>65</sub>	L <sub>66</sub>	L <sub>67</sub>	L <sub>68</sub>	L <sub>69</sub>	L <sub>70</sub>	L <sub>71</sub>	L <sub>72</sub>	L <sub>73</sub>	L <sub>74</sub>	L <sub>75</sub>	L <sub>76</sub>	L <sub>77</sub>	L <sub>78</sub>	L <sub>79</sub>	L <sub>80</sub>	L <sub>81</sub>	L <sub>82</sub>	L <sub>83</sub>	L <sub>84</sub>	L <sub>85</sub>	L <sub>86</sub>	L <sub>87</sub>	L <sub>88</sub>	L <sub>89</sub>	L <sub>90</sub>	L <sub>91</sub>	L <sub>92</sub>	L <sub>93</sub>	L <sub>94</sub>	L <sub>95</sub>	L <sub>96</sub>	L <sub>97</sub>	L <sub>98</sub>	L <sub>99</sub>	L <sub>100</sub>	Weight
120-049-349	CHN-75S	Stainless Steel	75	20	6	20	10	50	30	31.5	25	35	8	32	12	11	10	8	2	3	6	M6	125g																																																																																
120-049-348	CHN-80S	Stainless Steel	80	25	8	25	13	60	40	37.5	30	40	10	40	15	14	12	8	2	3	8	M8	225g																																																																																
120-049-347	CHN-90S	Stainless Steel	90	30	10	30	15	75	50	45	35	45	12	50	20	17	14	10	3	4	10	M10	390g																																																																																
120-039-406	CHN-75Y	Steel	75	20	6	20	10	50	30	31.5	25	35	8	32	12	11	10	8	2.3	3.2	6	M6	125g																																																																																
120-039-405	CHN-80Y	Steel	80	25	8	25	13	60	40	37.5	30	40	10	40	15	14	12	8	2.3	4	8	M8	225g																																																																																
120-039-404	CHN-90Y	Steel	90	30	10	30	15	75	50	45	35	45	12	50	20	17	14	10	3	4	10	M10	390g																																																																																

# DRAW LATCH (CLEAN ROOM)

LOAD CAPACITY  
330kgf

STAINLESS  
316  
STEEL

# STF-CV150

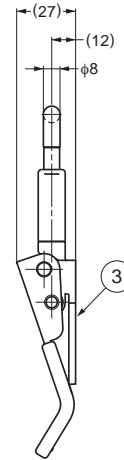
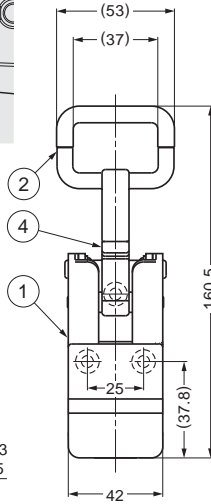
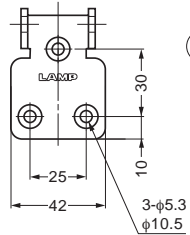

- No metal-to-metal contact.
- Ideal for clean room, semiconductor, and food industry applications.
- When used in combination with the TF40C counter plate (below) will have 300kg load capacity.

### Hook (Option)

Item Code	Item Name	Finish
120-014-142	TF40C-ST	Polished
120-014-143	TF40C-STM	Mirror

### Body

Item Code	Item Name	Material	Finish	Load Capacity	Weight
120-040-481	STF-CV150	Stainless Steel(SUS316)	Mirror	3300N 330kgf	248g
120-014-141	STF-CV150M	Stainless Steel(SUS316)	Mirror	3300N 330kgf	248g

No.	Part Name	Material	Finish
①	Handle	Stainless Steel(SUS316)	Mirror
②	Hook	Stainless Steel(SCS14)	Mirror
③	Base	Stainless Steel(SUS316)	Mirror
④	Hook Screw	Stainless Steel(SCS14)	Mirror

# HEAVY DUTY COUNTERPLATE

# TF40C

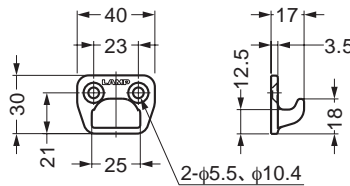

- Heavy duty counterplate for STF-CV150 clean room draw latch.

Item Code	Item Name	Material	Finish	Weight
120-014-142	TF40C-ST	Stainless Steel (SCS14)	Polished	48g
120-014-143	TF40C-STM	Stainless Steel (SCS14)	Mirror	48g

## CLEAN MAGNETIC CATCHES DIGEST



MC-JM45WT



MC-JM63G

## CLEAN HINGES & STAY DIGEST

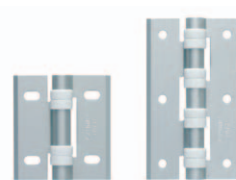

HG-CV

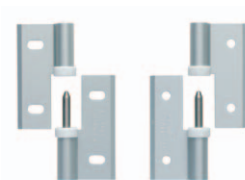

HG-CV-65N



LB-CV215A

# CORNER FASTENER (W/LOCK)



# STF-C64A, B

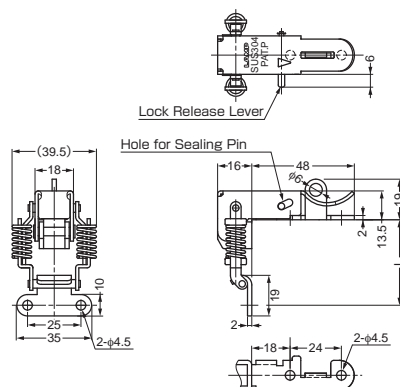
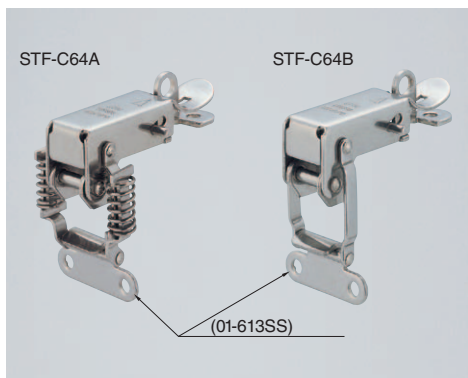

STF-C64A With Spring

- Latch mounts on corner to draw perpendicular surfaces together.
- Designed to allow front operation.
- Padlock and secondary catch options.
- Pull lever and lift latch to open.
- Available with or without spring.

LSize mm ±0.5	Clamping Force N ±14	Clamping Force kgf ±1.5
40	0N ±14	0kgf ±1.5
41	58.6N ±14	6.0kgf ±1.5
42	71.3N ±14	7.3kgf ±1.5
43	83.9N ±14	8.6kgf ±1.5
44	96.5N ±14	9.9kgf ±1.5

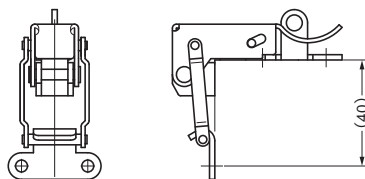

STF-C64B Without Spring

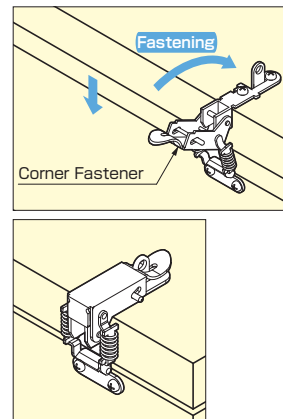

### Body

Item Code	Item Name	Spec.	Material	Finish	Door Thickness	Weight	Box	Carton
120-042-200	STF-C64A	With Spring	Stainless Steel(SUS304)	Mirror	14~ 28	66.5g	15pcs	210pcs
120-042-201	STF-C64B	Without Spring	Stainless Steel(SUS304)	Mirror	14~ 28	60g	15pcs	210pcs

### Installation

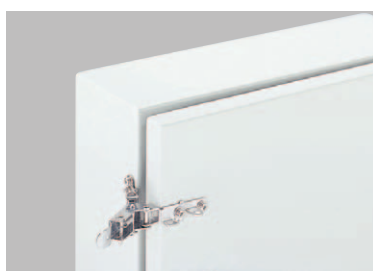
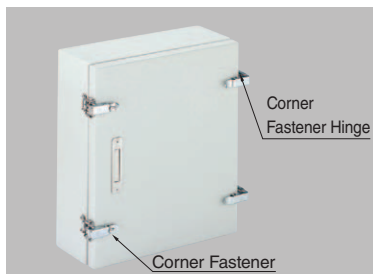

### Sealing Pin (Option)

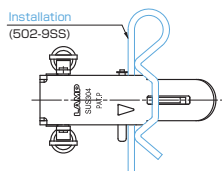

Material	Finish
Stainless Steel(SUS304)	Plain

Item Code	Item Name	A	B	C	φD
120-041-822	502-7SS	38	43	13	1.8

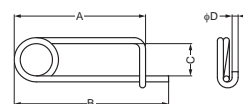

Item Code	Item Name	E	F	G	φH
120-041-823	502-9SS	63	66	18	2.6
120-041-825	613-9SS	55	59	15	2.3

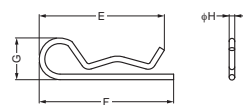

### Strike Hook (Option)

Item Code	Item Name	Material	Finish
120-040-415	01-613SS	Stainless Steel(SUS304)	Polished

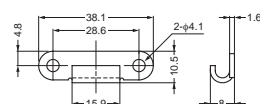

Item Code	Item Name	Material	Finish
120-040-421	02-613SS	Stainless Steel(SUS304)	Polished

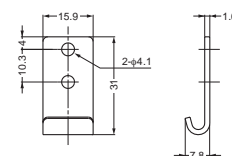

Item Code	Item Name	Material	Finish
120-040-452	07-613SS	Stainless Steel(SUS304)	Polished

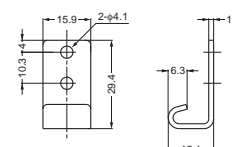

# CORNER FASTENER HINGE (W/LOCK)



## STH-C64



- Compresses cover to achieve better sealing.
  - Works with STF-C64 fastener.
  - To be used with rubber gasket.
  - Designed to allow front operation.
  - Locks when fastened to prevent accidental release.
  - Pull lever and lift latch to open.
- Door size: W300 x H400 /pair  
 Door thickness: t = 24mm ~ 28mm  
 Door weight: Max. 2.8 kg (6.1 lbs) /pair

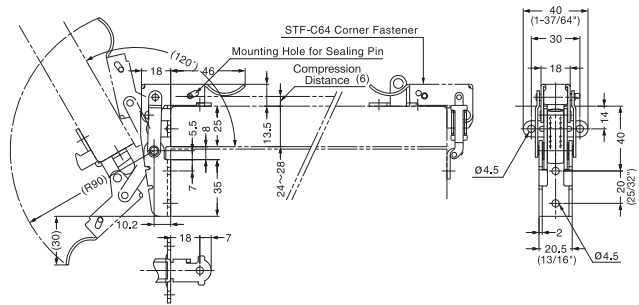
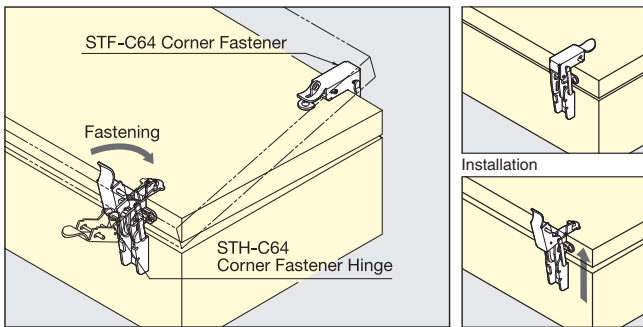
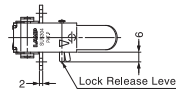

Item Code	Item Name	Weight (g)	Box (pcs)	Carton (pcs)
120-091-430	STH-C64	90	10	140

Material	Finish
304 Stainless Steel	Polished

# CORNER FASTENER



## STF-A56AH, AC

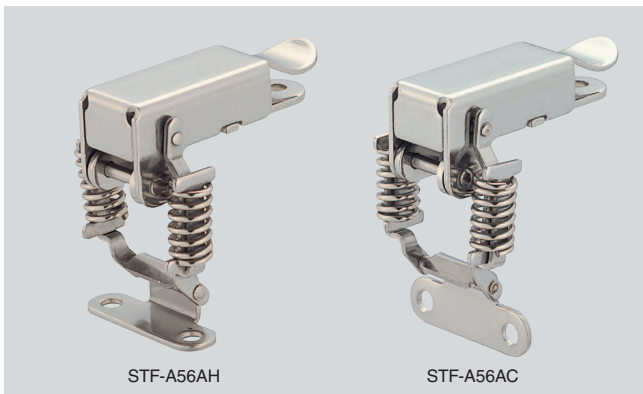

- Latch mounts on corner to draw perpendicular surfaces together.
- Designed to allow front operation.
- Available in two different counter plate styles.
- Provides constant holding tension for secure latching.

STF-A56AH

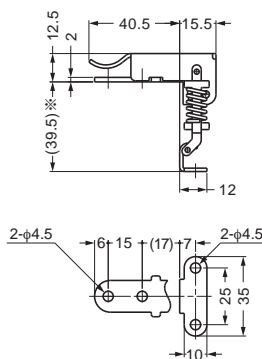

Dimension shown is in case of clamping force"0".

STF-A56AC

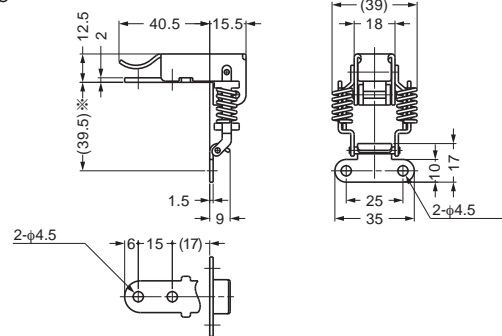

Dimension shown is in case of clamping force"0".

Item Code	Item Name	Material	Finish
120-040-480	STF-A56AH	Stainless Steel(SUS304)	Mirror

Item Code	Item Name	Material	Finish
120-040-479	STF-A56AC	Stainless Steel(SUS304)	Mirror

## COMPRESSION DRAW LATCH



### SCC-60

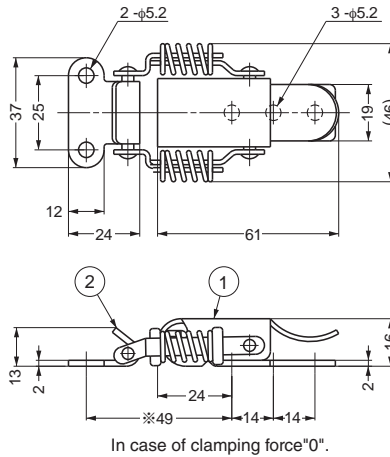

- Spring loaded design compensates for tolerance and vibrations.
- Provides constant hold tension for secure latching.

No.	Part Name	Material	Finish
①	Body	Stainless Steel(SUS304)	Polished
②	Strike	Stainless Steel(SUS304)	Polished

Item Code	Item Name
120-043-981	SCC-60

## COMPRESSION DRAW LATCH



### SCC-40

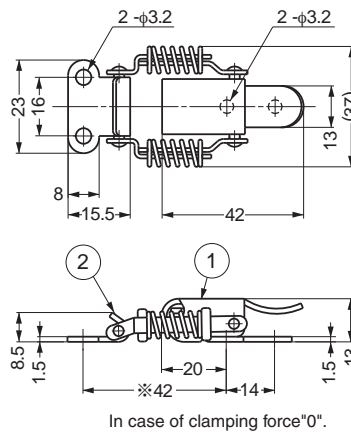

- Spring loaded design compensates for tolerance and vibrations.
- Provides constant hold tension for secure latching.

No.	Part Name	Material	Finish
①	Body	Stainless Steel(SUS304)	Polished
②	Strike	Stainless Steel(SUS304)	Polished

Item Code	Item Name
120-043-980	SCC-40

## COMPRESSION DRAW LATCH



### SCC-30

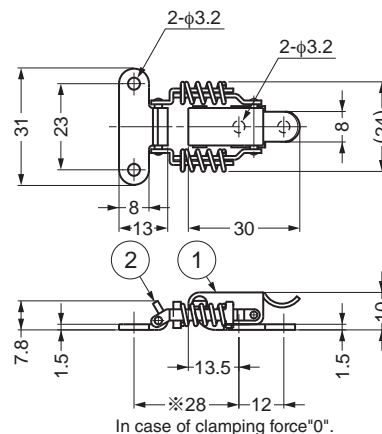

- Spring loaded design compensates for tolerance and vibrations.
- Provides constant hold tension for secure latching.

No.	Part Name	Material	Finish
①	Body	Stainless Steel(SUS304)	Polished
②	Strike	Stainless Steel(SUS304)	Polished

Item Code	Item Name
120-040-693	SCC-30

## COMPRESSION DRAW LATCH



### SCCA-60

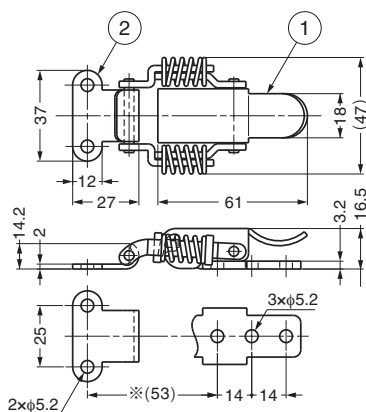

※Dimension shown is in case of clamping force"0".

- Spring loaded design compensates for tolerance and vibrations.
- Provides constant hold tension for secure latching.

No.	Part Name	Material	Finish
①	Body	Steel	Clear Zinc Chromate
②	Counter Plate	Steel	Clear Zinc Chromate

  

Item Code	Item Name	Weight
120-049-303	SCCA-60	102g

## COMPRESSION DRAW LATCH



### SCCA-40

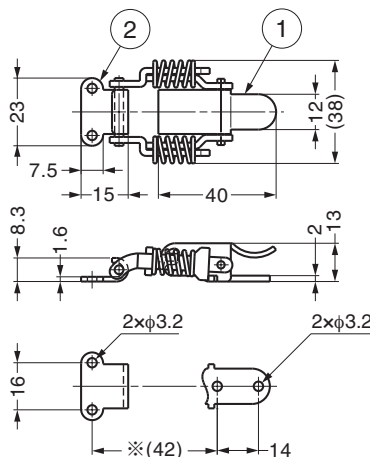

※Dimension shown is in case of clamping force"0".

- Spring loaded design compensates for tolerance and vibrations.
- Provides constant hold tension for secure latching.

No.	Part Name	Material	Finish
①	Body	Steel	Clear Zinc Chromate
②	Counter Plate	Steel	Clear Zinc Chromate

Item Code	Item Name	Weight
120-049-179	SCCA-40	38g

## CORNER FASTENER

### PS34A

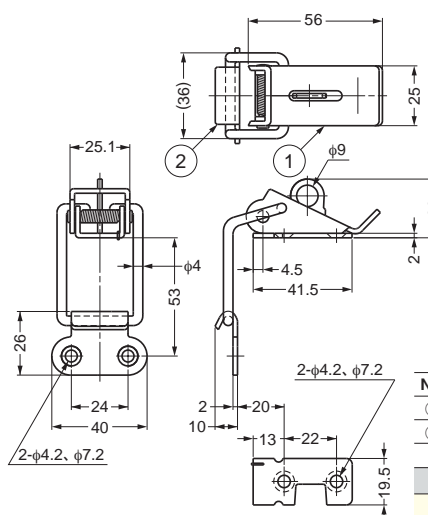

- Latch mounts on corner to draw perpendicular surfaces together.
- Designed to allow front operation.
- Padlock and secondary catch options.

No.	Part Name	Material	Finish
①	Body	Stainless Steel(SUS304)	Polished
②	Counterplate	Stainless Steel(SUS304)	Polished

Item Code	Item Name	※ Tension Force	Weight
120-049-193	PS34A	147N 15kgf	88g

※Dimension shown is in case of clamping force"0".

# DRAW LATCH



PS

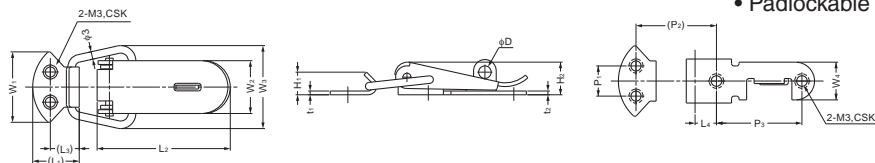

Item Code	Item Name	Type	L <sub>1</sub>	L <sub>2</sub>	L <sub>3</sub>	L <sub>4</sub>	W <sub>1</sub>	W <sub>2</sub>	W <sub>3</sub>	W <sub>4</sub>	H <sub>1</sub>	H <sub>2</sub>	t <sub>1</sub>	t <sub>2</sub>	P <sub>1</sub>	(P <sub>2</sub> )	P <sub>3</sub>	Ø D	Tension Force	
120-040-476	PS31A	With Pad Lock Hole	16	40	10	8	23	16	26	13	9	9.5	1.2	1	10	30	23	5	98N	10kgf
120-040-475	PS30A	With Pad Lock Hole	18	53	11.5	8.5	28	21	32	15	10	13	1.5	1.5	12	33	34	5.5	147N	15kgf
120-049-188	PS31	Without Pad Lock Hole	19	38	11	7	24	16	26	13	8	9.5	1.2	1	10	30	23	-	98N	10kgf
120-049-671	PS30	Without Pad Lock Hole	18	53	11.5	8.5	28	21	32	15	10	13	1.5	1.5	12	33	34	-	147N	15kgf

Material	Finish
Stainless Steel(SUS304)	Polished

Material	Finish
Brass	Chrome

Item Code	Item Name	Type	L <sub>1</sub>	L <sub>2</sub>	L <sub>3</sub>	L <sub>4</sub>	W <sub>1</sub>	W <sub>2</sub>	W <sub>3</sub>	W <sub>4</sub>	H <sub>1</sub>	H <sub>2</sub>	t <sub>1</sub>	t <sub>2</sub>	P <sub>1</sub>	(P <sub>2</sub> )	P <sub>3</sub>	Ø D	Tension Force	
120-049-313	P31A	With Pad Lock Hole	16	40	9.5	8	24	16	27.5	13	9	9	1.2	1	10	29	23	5	78N	8kgf
120-049-311	P30A	With Pad Lock Hole	18.5	53	11.5	9	28	21	33	15	9	13	1.5	1.5	12	32	34	5.2	98N	10kgf
120-049-314	P31	Without Pad Lock Hole	16	40	9.5	8	24	16	27.5	13	9	9	1.2	1	10	29	23	-	78N	8kgf
120-049-312	P30	Without Pad Lock Hole	18.5	53	11.5	9	28	21	33	15	9	13	1.5	1.5	12	32	34	-	98N	10kgf

# DRAW LATCH

P3

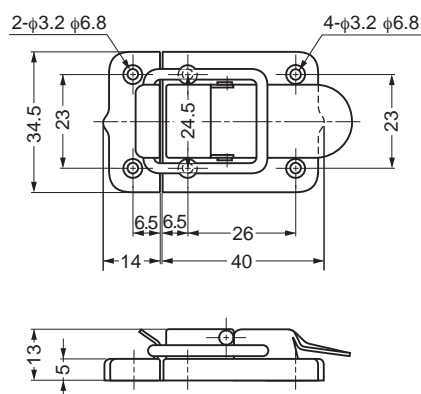

Item Code	Item Name	Material	Finish	Weight	Box
120-049-395	P3	Steel	Nickel	29.3g	100pcs

# DRAW LATCH

P3-10N

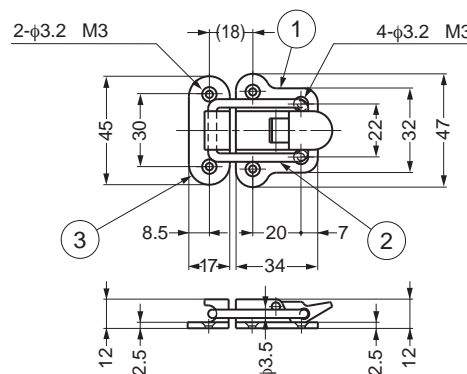

●Dimensions shown in case of clamping force"0".

Item Code	Item Name	※ Tension Force	Weight
120-049-125	P3-10N	147N	15kgf

No.	Part Name	Material	Finish
①	Body	Zinc Alloy	Chrome
②	Hook	Stainless Steel(SUS304)	Plain
③	Counterplate	Zinc Alloy	Chrome

## DRAW LATCH

STAINLESS  
304  
STEEL

P100

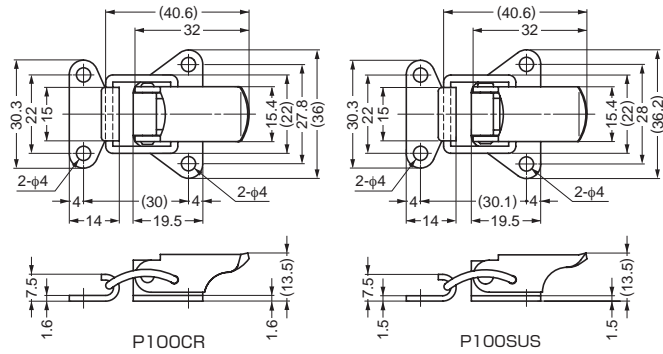

Item Code	Item Name	Material	Finish	Weight	Box
120-041-058	P100CR	Steel	Chrome	24g	100pcs
120-044-003	P100SUS	Stainless Steel(SUS304)	-	22.5g	100pcs

## DRAW LATCH

P3-12, P3-11

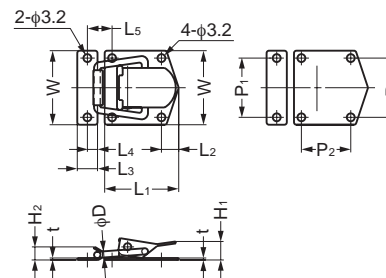

Item Code	Item Name	Material	Finish	L <sub>1</sub>	L <sub>2</sub>	L <sub>3</sub>	L <sub>4</sub>	(L <sub>5</sub> )	W	H <sub>1</sub>	H <sub>2</sub>	t	P <sub>1</sub>	P <sub>2</sub>	φ D	* Tension Force	Weight	
120-049-317	P3-12	Brass	Chrome	30	7	8	4	10	30	9.5	5	0.8	24	20	2.5	49N	5kgf	15g
120-049-316	P3-11	Brass	Chrome	40	10	11	5.5	14	37	12	8	1.2	29	25	3	78N	8kgf	30g

## DRAW LATCH

STAINLESS  
304  
STEEL

PS, P

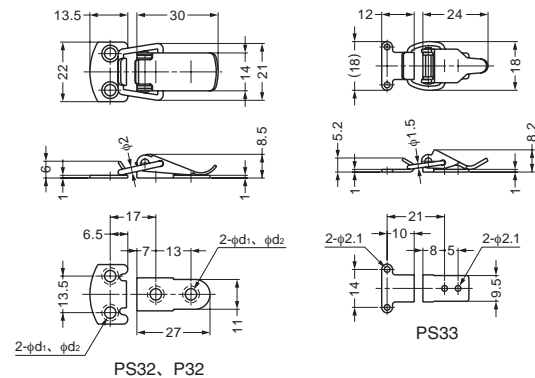

Item Code	Item Name	Material	Finish	Tension Force	Weight			
120-049-672	PS33	Stainless Steel(SUS304)	Polished	49N	5kgf	6g		
Item Code	Item Name	Material	Finish	L <sub>1</sub>	φ d <sub>2</sub>	Tension Force	Weight	
120-059-452	PS32	Stainless Steel(SUS304)	Polished	7.5	5.2	78N	8kgf	11g
120-049-318	P32	Steel	Chrome	7.5	4.2	78N	8kgf	12g

## DRAW LATCH

RoHS  
4

STAINLESS  
304  
STEEL

PS35

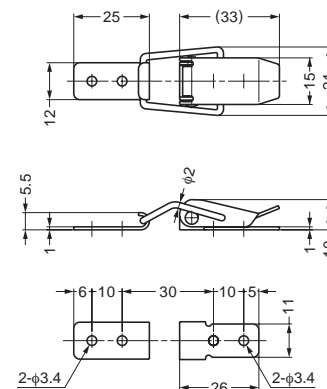

Item Code	Item Name	Material	Finish	Tension Force	Weight	Box	
120-049-345	PS35	Stainless Steel(SUS304)	Polished	19N	2kgf	15g	500pcs



**FASTENER**

**P34**

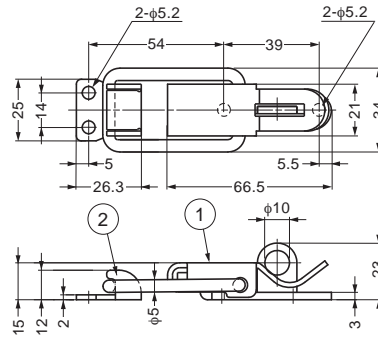

- M5 pan head screw with cross hole.

No.	Part Name	Material	Finish
①	Body	Steel	Yellow Zinc Chromate
②	Counterplate	Steel	Yellow Zinc Chromate

Item Code	Item Name	Weight
120-049-015	P34	89g

**FASTENER**

**P11**

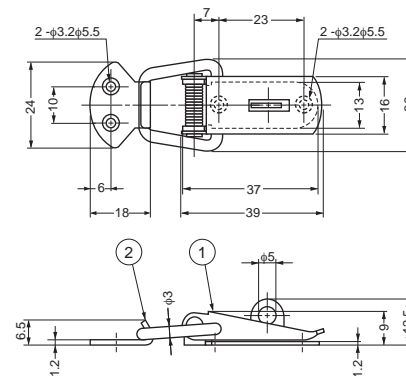

- Lever spring avoid lever to move during opening/fastening.

No.	Part Name	Finish
①	Body	Chrome
②	Counter Plate	Chrome

Item Code	Item Name	Material	Weight	Box
120-044-004	P11	Steel	17.3g	200pcs

**FASTENER**

**P8**

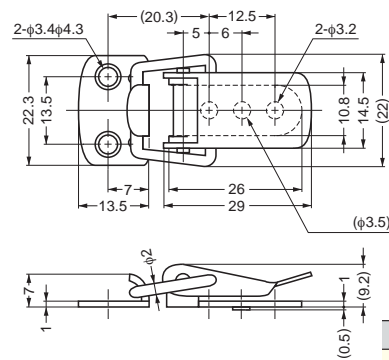

- Lever spring avoid lever to move during opening/fastening.

Item Code	Item Name	Material	Finish	Weight	Box
120-048-025	P8	Steel	Chrome	10.2g	250pcs

**FASTENER**

**P91**

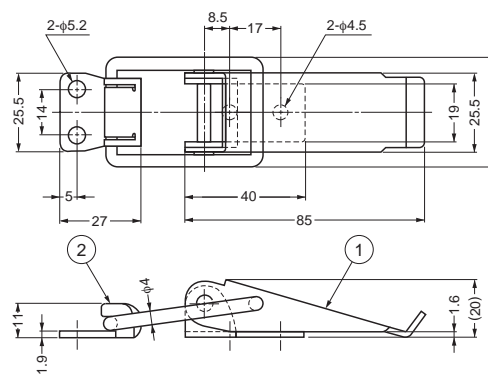

No.	Part Name	Material	Finish
①	Body	Steel	Clear Zinc Chromate
②	Counter Plate	Steel	Clear Zinc Chromate

Item Code	Item Name	Weight	Box
120-040-507	P91	79g	100pcs

# DRAW LATCH (W/HANDLE)

LOAD CAPACITY  
100 kgf

NO SCREW

## THF-100



- With handle and safety lever.
- Push safety lever and lift latch to open.
- Spring loaded to hold handle in retracted position.
- Includes a function to allow use for pad lock or tamper indicator seals. (Pad lock and wire not included)

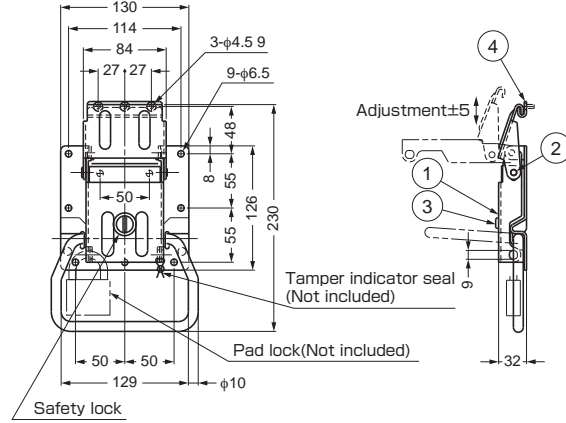

### Adjustment

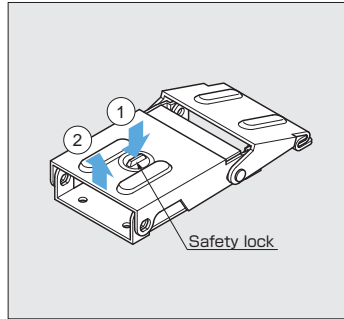
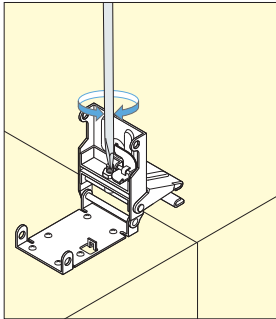

No.	Part Name	Material	Finish
①	Body	Steel	Yellow Zinc Chromate
②	Shaft	Stainless Steel(SUS304)	—
③	Safety Lever	Stainless Steel(SUS304)	—
④	Strike	Steel	Yellow Zinc Chromate

Item Code	Item Name	Load Capacity	Weight	Carton
120-040-506	THF-100	980N 100kgf	1064g	10pcs

# DRAW LATCH

TEST

LOAD CAPACITY  
75 kgf

NO SCREW

## THF-75



- Safety lever prevents accidental release.
- Push the safety lever and lift latch to open.
- Includes a function to allow use for pad lock or tamper indicator seals. (Pad lock and wire not included)

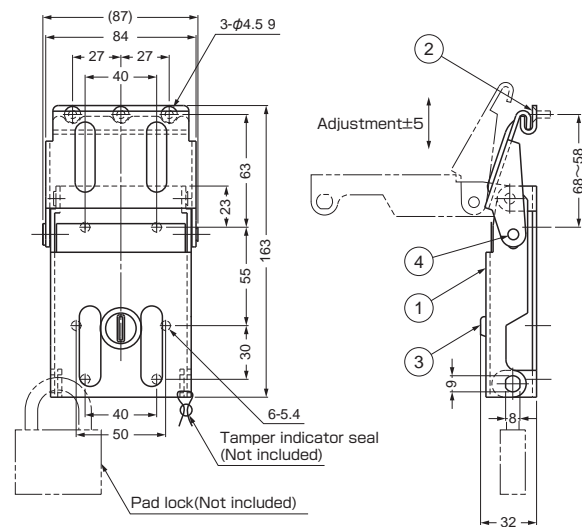

### Adjustment

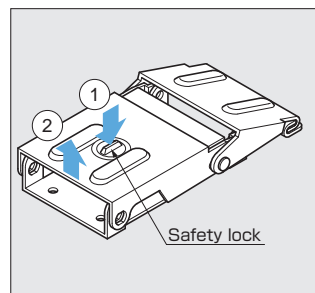
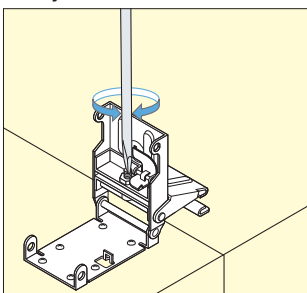

No.	Part Name	Material	Finish
①	Body	Steel	Yellow Zinc Chromate
②	Shaft	Stainless Steel(SUS304)	—
③	Safety Lever	Stainless Steel(SUS304)	—
④	Strike	Steel	Yellow Zinc Chromate

Item Code	Item Name	Load Capacity	Weight	Carton
120-040-505	THF-75	730N 75kgf	657g	20pcs

# MINI DRAW LATCH



## PN-51



- Lift handle and turn 180° open and close latch.
  - Small stainless draw latch with key.
- Note: key changes are not available.

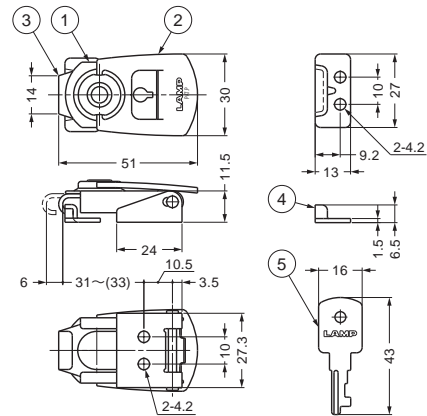

No.	Part Name	Material	Finish
①、②	Body, Lever	Stainless Steel(SUS304)	Plain
③	Hook	Stainless Steel(SUS304)	Plain
④	Counter plate	Stainless Steel(SUS304)	Plain
⑤	Key	Steel	Nickel

Item Code	Item Name	Weight	Box
120-040-489	PN-51	50g	40pcs

# DRAW LATCH



## P-1040/SS

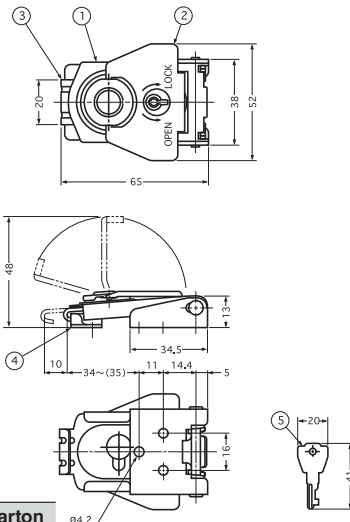

- Lift handle and turn 180° open and close latch.
  - Stainless draw latch with key.
- Note: key changes are not available.

Item Code	Item Name	Weight	Box	Carton
120-049-413	P-1040/SS	105g	60pcs	240pcs

No.	Part Name	Material	Finish
①	Body	304 Stainless Steel	Polished
②	Lever		
③	Hook	430 Stainless Steel	
④	Counterplate	304 Stainless Steel	
⑤	Key	Steel	Nickel

# DRAW LATCH



## P-102H/SS

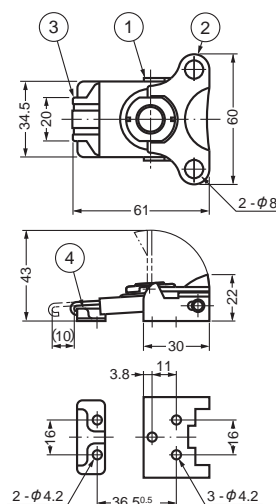

- Lift handle and turn 180° open and close latch.

Item Code	Item Name	Weight	Box	Carton
120-049-234	P-102H/SS	85g	60pcs	600pcs

No.	Part Name	Material	Finish
①	Body	304 Stainless Steel	Polished
②	Lever		
③	Hook	430 Stainless Steel	
④	Counterplate	304 Stainless Steel	

# PUSH LOCK FASTENER (LARGE/FLUSH TYPE)

# 251F, 151F



- 2 piece fastener allows for fast and easy access with complete removal of panel.
  - Attach socket into outer panel / plug into removable panel.
  - Insert plug into socket and push to lock / unlock.
- Flush locked design prevents snagging.
- Fastens plastic or sheet metal panels.

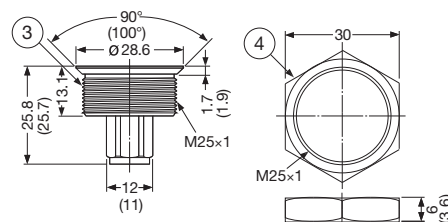
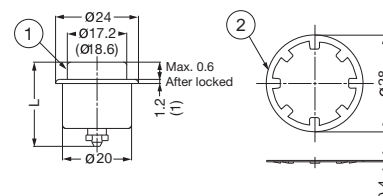
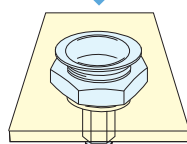
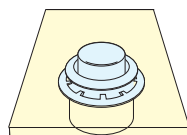

## Preparation (Plug)

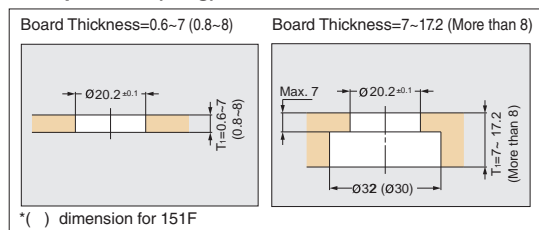

\* ( ) dimension for 151F

## Preparation (Socket)

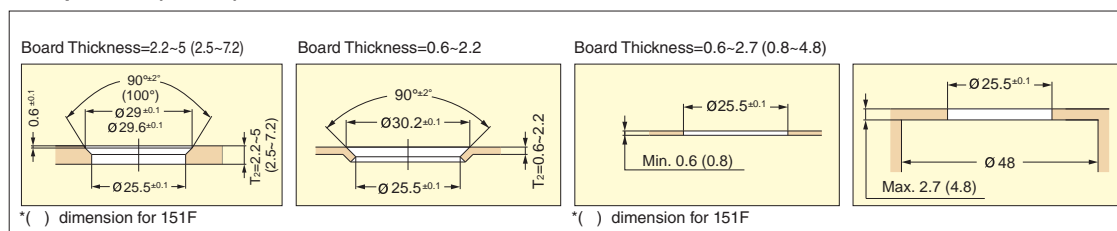

\* ( ) dimension for 151F

## Grip Dimensions

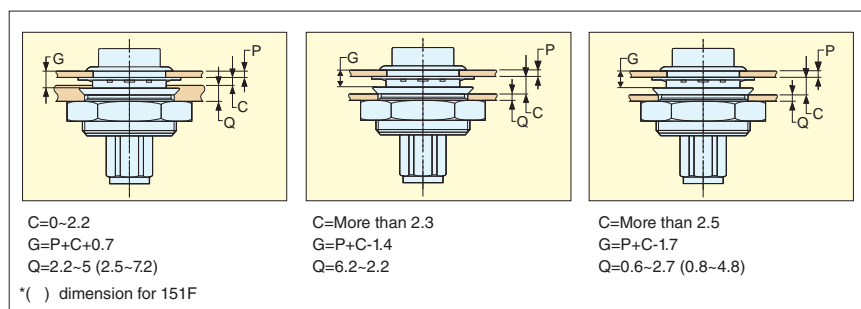

\* ( ) dimension for 151F

## 251F

Item Code	Set Item Name	Grip Dimension G	Plug Dimension L	Retaining Force	Weight
120-040-259	251F-01-3	1.2~ 2	20.5	245N 25kgf	15g
120-040-260	251F-02-3	2~ 2.8	21	245N 25kgf	15g
120-040-261	251F-03-3	2.8~ 3.6	22	245N 25kgf	15g
120-040-262	251F-04-3	3.6~ 4.4	23	245N 25kgf	15g
120-040-263	251F-05-3	4.4~ 5.2	23.5	245N 25kgf	15g
120-040-264	251F-06-3	5.2~ 6	24.5	245N 25kgf	16g

No.	Part Name	Material	Finish
①	Plug	Polyacetal	Black
②	Ring	Steel	Black
③	Socket	Polyacetal	Black
④	Nut	Polyacetal	Black

## 151F

Item Code	Set Item Name	Grip Dimension G	Plug Dimension L	Retaining Force	Weight
120-013-718	151F-01-2	1.2~ 2	20.5	245N 25kgf	15g
120-013-719	151F-02-2	2~ 2.8	21	245N 25kgf	15g
120-013-720	151F-03-2	2.8~ 3.6	22	245N 25kgf	15g
120-013-721	151F-04-2	3.6~ 4.4	23	245N 25kgf	15g
120-013-722	151F-05-2	4.4~ 5.2	23.5	245N 25kgf	15g
120-013-723	151F-06-2	5.2~ 6	24.5	245N 25kgf	16g

No.	Part Name	Material	Finish
①	Plug	Brass	Chrome
②	Ring	Steel	Black
③	Socket	Brass	Nickel
④	Nut	Zinc Alloy	Nickel

# PUSH LOCK FASTENER (MINI/FLUSH TYPE)

# 252F, 152F



- 2 piece fastener allows for fast and easy access with complete removal of panel.
  - Attach socket into outer panel / plug into removable panel.
  - Insert plug into socket and push to lock / unlock.
- Flush locked design prevents snagging.
- Fastens plastic or sheet metal panels.

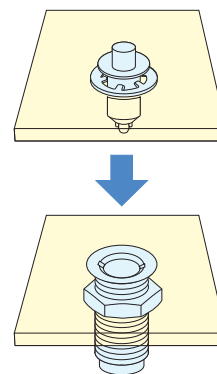

## Preparation (Plug)

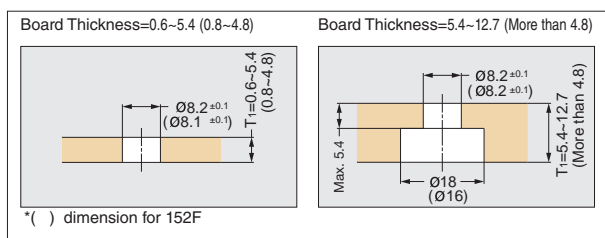

## Preparation (Socket)

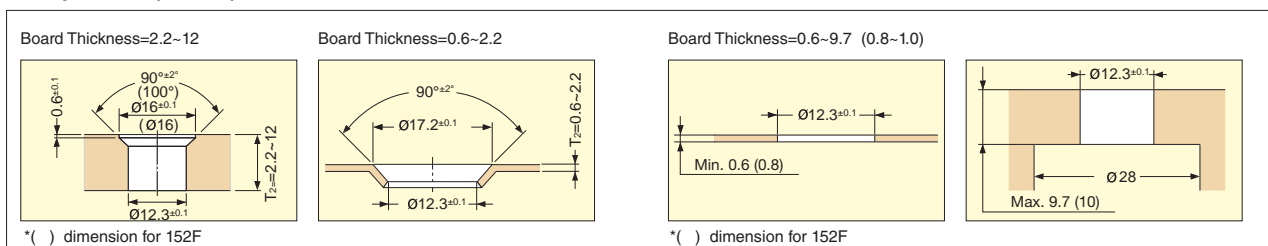

## Grip Dimensions

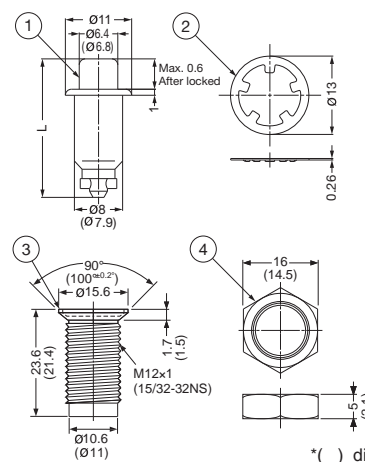
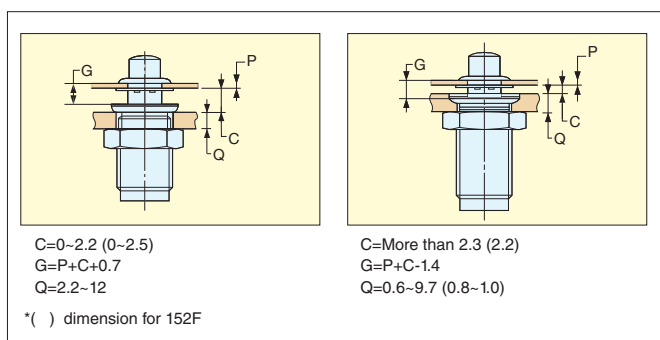

## 252F

Item Code	Set Item Name	Grip DimensionG	Plug DimensionL	Retaining Force	Weight
120-040-279	252F-01-3	1.2~ 2	18.5	147N 15kgf	6g
120-040-280	252F-02-3	2~ 2.8	19.0	147N 15kgf	6g
120-040-281	252F-03-3	2.8~ 3.6	20	147N 15kgf	6g
120-040-282	252F-04-3	3.6~ 4.4	20.5	147N 15kgf	6g
120-040-283	252F-05-3	4.4~ 5.2	21.5	147N 15kgf	6g
120-040-284	252F-06-3	5.2~ 6	22.5	147N 15kgf	6g

No.	Part Name	Material	Finish
①	Plug	Polyacetal	Black
②	Ring	Steel	Black
③	Socket	Polyacetal	Black
④	Nut	Polyacetal	Black

## 152F

Item Code	Set Item Name	Grip DimensionG	Plug DimensionL	Retaining Force	Weight
120-013-709	152F-01-1	1.2~ 2	18.5	147N 15kgf	6g
120-013-710	152F-02-1	2~ 2.8	19	147N 15kgf	6g
120-013-711	152F-03-1	2.8~ 3.6	20	147N 15kgf	6g
120-013-712	152F-04-1	3.6~ 4.4	20.5	147N 15kgf	6g
120-013-713	152F-05-1	4.4~ 5.2	21.5	147N 15kgf	6g
120-013-714	152F-06-1	5.2~ 6	22.5	147N 15kgf	6g

No.	Part Name	Material	Finish
①	Plug	Brass	Chrome
②	Ring	Steel	Passivation
③	Socket	Zinc Alloy	Clear Zinc Chromate
④	Nut	Steel	Chromate

# PUSH LOCK FASTENER (MINI/BUTTON TYPE)

# 255F, 155F



- 2 piece fastener allows for fast and easy access with complete removal of panel.
  - Attach socket into outer panel / plug into removable panel.
  - Insert plug into socket and push to lock / unlock.
- Flush locked design prevents snagging.
- Fastens plastic or sheet metal panels.

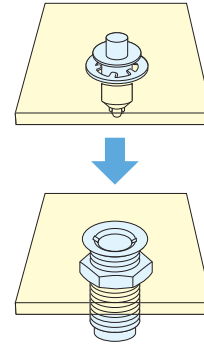

### Preparation (Plug)

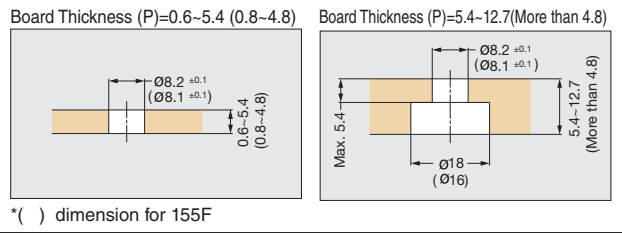

### Preparation (Socket)

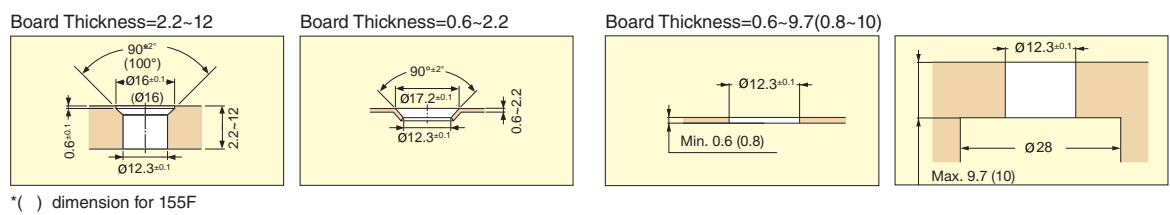

### Grip Dimensions

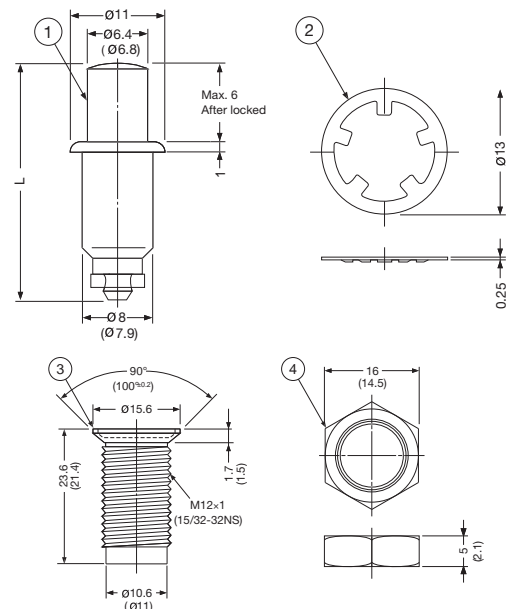
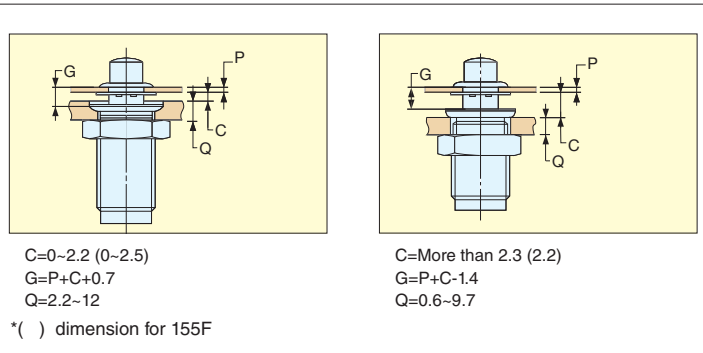

### 255F

Item Code	Set Item Name	Grip Dimension G	Plug Dimension L	Retaining Force	Weight
120-040-299	255F-01-3	1.2~2.8	23.5	147N 15kgf	6g
120-040-300	255F-03-3	2.8~4.4	25	147N 15kgf	6g
120-040-301	255F-05-3	4.4~6	25.5	147N 15kgf	6g

No.	Part Name	Material	Finish/Color
①	Plug	Poryaceta	Black
②	Ring	Steel	Black
③	Socket	Poryaceta	Black
④	Nut	Poryaceta	Black

### 155F

Item Code	Set Item Name	Grip Dimension G	Plug Dimension L	Retaining Force	Weight
120-013-715	155F-01-1	1.2~2.8	21.5	147N 15kgf	6g
120-013-716	155F-03-1	2.8~4.4	23	147N 15kgf	6g
120-013-717	155F-05-1	4.4~6	24.5	147N 15kgf	6g

No.	Part Name	Material	Finish
①	Plug	Zinc Alloy	Chrome
②	Ring	Steel	Passivation
③	Socket	Zinc Alloy	Clear Zinc Chromate
④	Nut	Steel	Clear Zinc Chromate

# PUSH LOCK FASTENER (PUSH-TURN TYPE)

# 149 SERIES

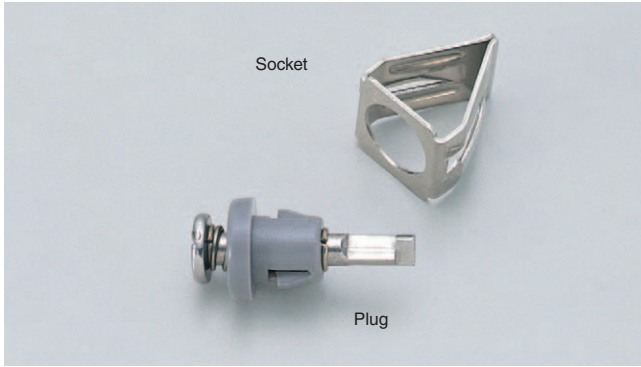

- 2 piece fastener allows for fast and easy access with complete removal of panel.
  - Attach socket into outer panel / plug into removable panel.
  - Insert plug into socket and push to lock / unlock.
- Flush design when locked prevents snagging.
- Fastens plastic or sheet metal panels.

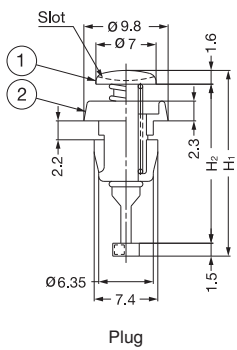

Plug

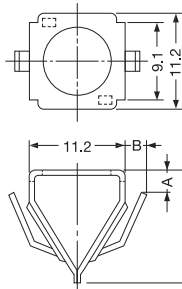

Socket

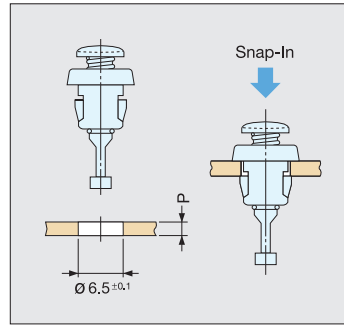

Preparation (Plug)

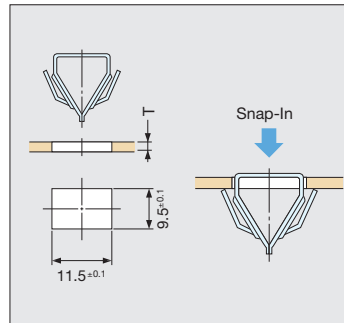

Preparation (Socket)

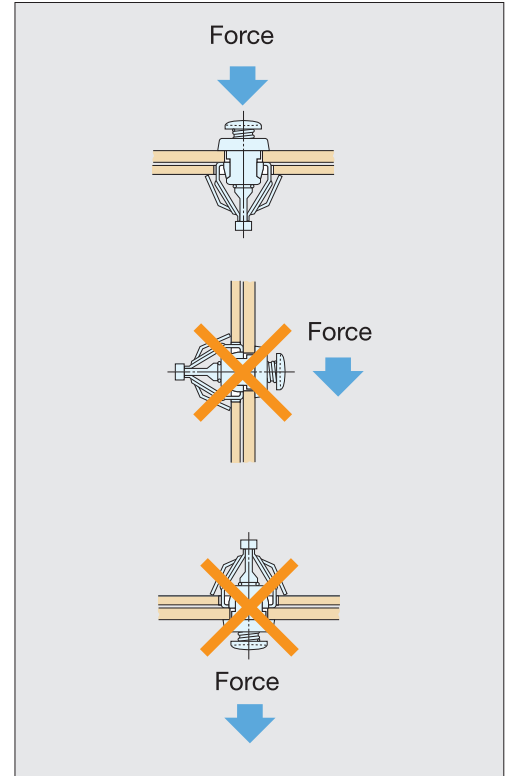

Application Example

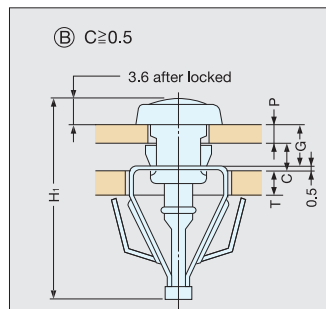
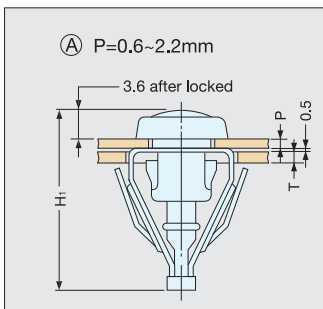

No.	Part Name	Material	Finish/Color
①	Pin	Stainless Steel(SUS430)	Plain
②	Cup	Plastic	Grey

### Plug

Item Code	Item Name	H <sub>1</sub>	H <sub>2</sub>	Weight
120-045-318	149S06-1-1AA	19.2	16.1	2g
120-049-416	149S06-2-1AA	20	16.9	2g
120-045-319	* 149S06-3-1AA	20.8	17.7	2g
120-048-022	149S06-4-1AA	21.6	18.5	2g
120-045-320	149S06-5-1AA	22.4	19.3	2g

\* Made to order

### Socket

Item Code	Item Name	A	B	Board Thickness T	Material	Weight
120-045-322	149R02-2-1AA	2.6	1.7	1.2 ~ 1.8	Stainless Steel(SUS304)	1g
120-045-323	149R02-3-1AA	3.6	7.9	1.8 ~ 2.6	Stainless Steel(SUS304)	1g

Ⓐ

Item Code	Item Name	Board Thickness P	H <sub>1</sub>
120-045-318	149S06-1-1AA	0.6~1.4	19.2
120-049-416	149S06-2-1AA	1.4~2.2	20

Ⓑ

Item Code	Item Name	G = T <sub>1</sub> + C - 0.5	Board Thickness P	C
120-045-318	149S06-1-1AA	0.6~1.4	0.6~1.4	1.3~0.5
120-049-416	149S06-2-1AA	1.4~2.2	0.6~2.2	2.1~0.5
120-045-319	* 149S06-3-1AA	2.2~3	0.6~2.2	2.9~1.3
120-048-022	149S06-4-1AA	3~3.8	0.6~2.2	3.7~2.1
120-045-320	149S06-5-1AA	3.8~4.6	0.6~2.2	4.5~2.9

\* Made to order

# LATCH HANDLE

# LH-203



### Installation

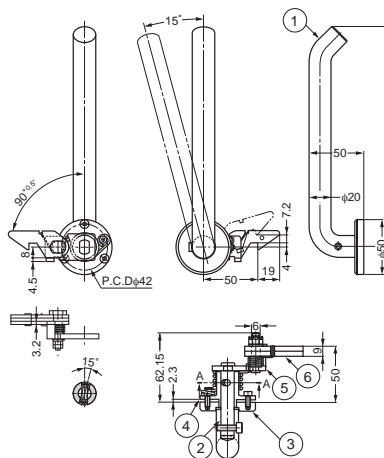
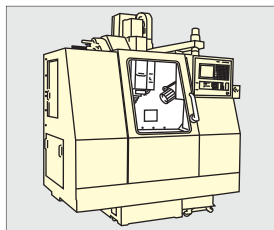

No.	Part Name	Material	Finish
①	Handle	Aluminum Alloy	Black
②	Axis	Steel	Yellow Zinc Chromate
③	Bracket	Brass	Black
④	Mounting Plate	Steel	Yellow Zinc Chromate
⑤	Plate A	Steel	Yellow Zinc Chromate
⑥	Plate B	Steel	Yellow Zinc Chromate

  

Item Code	Item Name	Weight
140-010-223	LH-203	500g

# FLUSH SLAM LATCH



# LC-65A

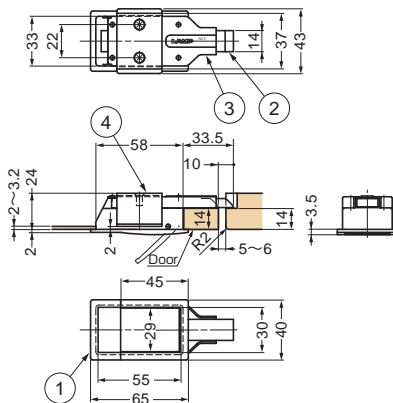

- Door will be latched when closed.
  - Pull paddle handle to open.
  - Non-Handed: Can be installed on left or right side.
  - Designed for panel thickness 2.0~3.2 mm.
  - Easy installation.
- Insert the latch body through cutout section and simply screw-on the back plate.

### Bore Dimensions

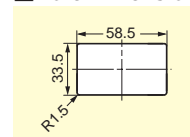

### Installation



### Sheet metal thickness

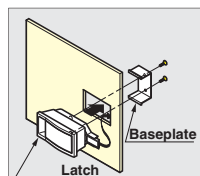

Item Code	Item Name	Door Thickness	Weight	Box	Carton
140-050-206	LC-65A	2 ~ 3.2	108g	10pcs	100pcs

No.	Part Name	Material	Finish
①	Body	Aluminum Alloy	Silver
②	Latch Bolt	Polyacetal	White
③	Cover	Stainless Steel(SUS304)	Polished
④	Base Plate	Stainless Steel(SUS304)	Polished

# FLUSH SLAM LATCH



# LC-48

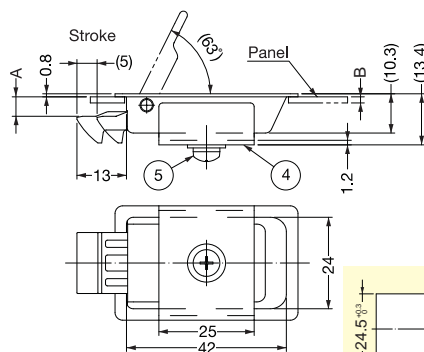

- Door will be latched when closed.
  - Pull paddle handle to open.
  - Non-Handed: Can be installed on left or right side.
  - UL-94 V0 rated flame retardant material.
  - Easy installation.
- Insert the latch body through cutout section and simply screw-on the back plate.

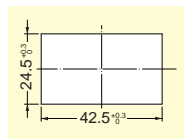
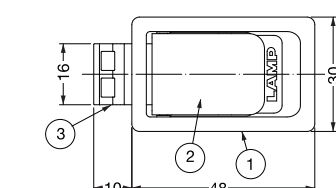

No.	Part Name	Material	Finish
①	Body	304 Stainless Steel	Plain
②	Lever		
③	Latch Bolt	PBT Plastic	White
④	Back Cover	304 Stainless Steel	Plain
⑤	Back Plate		

Item Code	Item Name	A	B	Weight (g)	Box (pcs)	Carton (pcs)
140-021-199	LC-48-3	3.5 (max. panel: 3.2mm)	1.0 ~ 1.6	35	40	400
140-021-200	LC-48-5	5.1 (max. panel: 4.6mm)	1.0 ~ 2.3	35	40	400



# FLUSH SLAM LATCH

# WB-900418, WB-900408

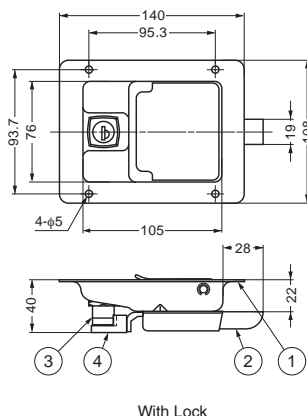

- Door will be latched when closed.
- Pull paddle handle to open.
- Max. 150 key changes available as made to order.
- With waterproof gasket.

### ■ Bore Dimensions

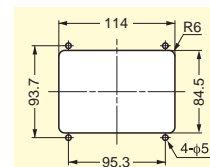

Item Code	Item Name	Spec.	Key type
140-010-030	WB-900418-B	With lock	Key Different
140-010-031	WB-900418-D	With lock	Key Alike
140-010-009	WB-900408	Without lock	-

No.	Part Name	Material	Finish
①	Body	Stainless Steel(SUS304)	Mirror
②	Latch Bolt	Steel	Clear Zinc Chromate
③	Cylinder	Zinc Alloy	Chrome
④	Cam	Steel	Clear Zinc Chromate

# FLUSH SLAM LATCH



# P10

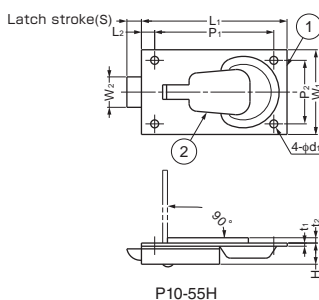
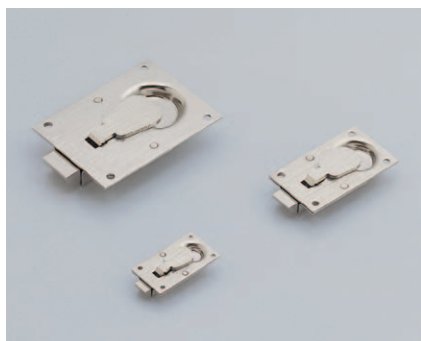

### ■ Bore Dimensions

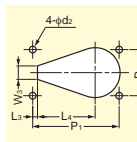

- Flush slam latch ideal for cover panels and small applications.
- Panel is latched when tab is flush, and released by pulling up the tab.
- Tab will stay in both flush and extended position.
- Ideal for multiple latch panels.

No.	Part Name	Material	Finish
①	Body	Brass	Nickel
②	Lever	Brass	Nickel

Item Code	Item Name	L <sub>1</sub>	L <sub>2</sub>	L <sub>3</sub>	L <sub>4</sub>	W <sub>1</sub>	W <sub>2</sub>	W <sub>3</sub>	H	t <sub>1</sub>	t <sub>2</sub>	P <sub>1</sub>	P <sub>2</sub>	d <sub>1</sub>	d <sub>2</sub>	R	S	Weight
140-049-310	P10-26H	26	1.5	4	14	13	5	5	6	0.8	1.5	23	10	1.5	2	5	2.5	6g
140-049-309	P10-30H	30	3	1.5	18	17	5.8	6	6.5	1.2	2	25	13	1.5	2	6	3	11g
140-049-308	P10-38H	38	3	2	22.5	22	7.5	6	7.5	1.2	2	33	17.5	2	2.5	8.5	3.5	18g
140-049-307	P10-45H	45	4	2.5	26.5	26	10	6	8	1.2	2	37	20	2.5	3	9.5	4.5	28g
140-049-306	P10-55H	55	5	2.5	30	32	11.5	7	8	1.2	2	45	24	3	3.5	13	5.5	40g
140-049-305	P10-61H	61	5.5	5	32	45	15	11	11.5	1.2	2	50	38	3	3.5	14	7	66g

# FLUSH SLAM LATCH

# ATL-64

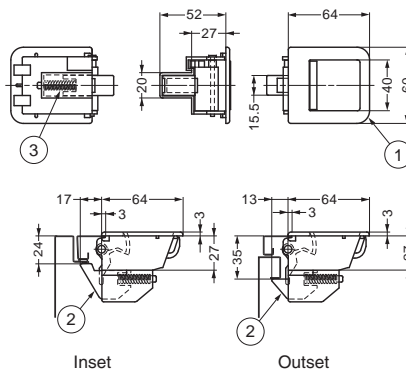
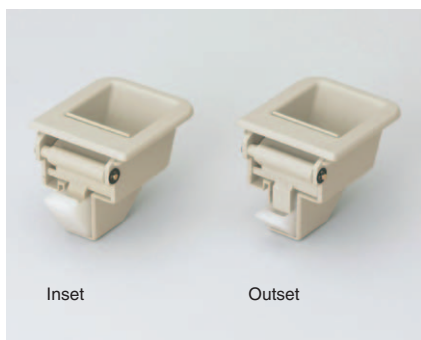

- Door will be latched when closed.
- Pull paddle handle to open.
- Non-Handed: Can be installed on left or right side.
- Available for inset and overlay doors.

### ■ Bore Dimensions

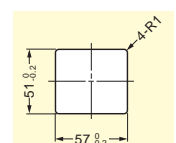

Item Code	Item Name	Spec.	Door Thickness	Weight	Box
140-012-014	ATL-64-IN	For InsetDoor	0.7 ~ 1	44.5g	175pcs
140-012-019	ATL-64-OT	For OutsetDoor	0.7 ~ 1	44.4g	175pcs

No.	Part Name	Material	Finish/Color
①	Body	ABS	Dark Ivory
②	Latch	Nylon	Natural
③	Spring	Stainless Steel(SUS304)	Plain

# FLUSH SLAM LATCH



## LJ-61

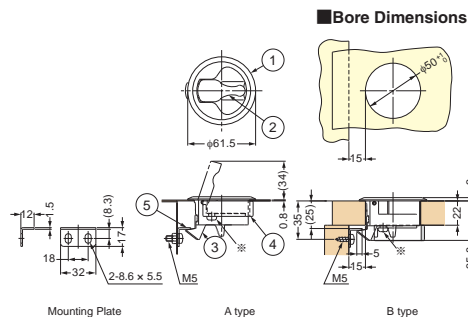

**Screw**

Spec.	Door Thickness	Screw
Type A	0.8~7.5	M5 × 12
Type A	8~12	M5 × 18
Type B	12.5~18.5	M5 × 12
Type B	19~22	M5 × 18

Item Code	Item Name	Color	Retaining Force (pc)	Box	Carton
140-050-031	LJ-61-BL	Black	147N	15kgf	10pcs 120pcs
140-059-200	LJ-61-WT	White	147N	15kgf	10pcs 120pcs

- Door will be latched when closed.
- Pull lever to open.
- Non-Handed: Can be installed on left or right side.
- All components are plastic, 304 or 316 stainless steel to provide high corrosion resistance.
- Easy installation.  
Insert the latch body through single round cutout or bore section and screw on the back plate.  
Back plate is designed to accommodate door thickness 0.8mm ~ 12mm, and also 12.5mm ~ 22mm by flipping over the back plate.

No.	Part Name	Material	Finish/Color
①	Body	Polycarbonate	Black, White
②	Lever	Polycarbonate	Black, White
③	Latch	Polyacetal	Black, White
④	Fixing plate	Polycarbonate	Black, White
⑤	Strike	Stainless Steel (SUS316)	Mirror

# FOLDING HANDLE LATCH

## WB-901503, WB-901504

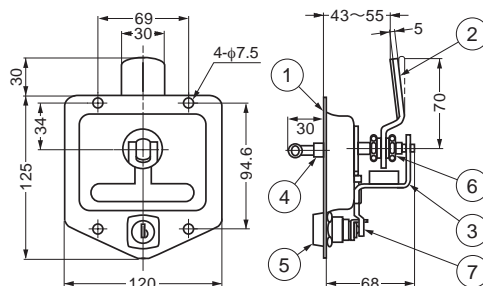

- Door can be sealed up.
- Height adjustable cam (12mm).
- With waterproof gasket.

No.	Part Name	Material	Finish
①	Body	Stainless Steel (SUS304)	Mirror
②	Cam	Steel	Yellow Zinc Chromate
③	Mounting plate	Steel	Yellow Zinc Chromate
④	Handle	Zinc Alloy	Chrome
⑤	Cylinder	Zinc Alloy	Chrome
⑥	Nut	Stainless Steel (SUS304)	Plain
⑦	Cam	Steel	Yellow Zinc Chromate

Item Code	Item Name	Spec.	KeyType
140-010-032	WB-901503-D	Anticlockwise	Key Alike
140-010-033	WB-901504-D	Clockwise	Key Alike

**Bore Dimensions**

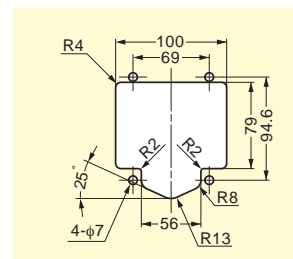

# FOLDING HANDLE LATCH

## WB-901551, WB-901552

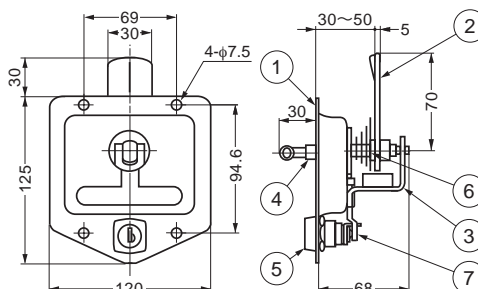

- Door can be sealed up.
- Height adjustable cam (12mm).
- With waterproof gasket.

No.	Part Name	Material	Finish
①	Body	Stainless Steel (SUS304)	Mirror
②	Cam	Steel	Yellow Zinc Chromate
③	Mounting plate	Steel	Yellow Zinc Chromate
④	Handle	Zinc Alloy	Chrome
⑤	Cylinder	Zinc Alloy	Chrome
⑥	Spring	Steel	Plain
⑦	Cam	Steel	Yellow Zinc Chromate

Item Code	Item Name	Spec.	KeyType
140-010-034	WB-901551-D	Anticlockwise	Key Alike
140-010-035	WB-901552-D	Clockwise	Key Alike

**Bore Dimensions**

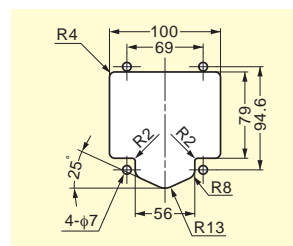

# DAMPER CATCH

DC

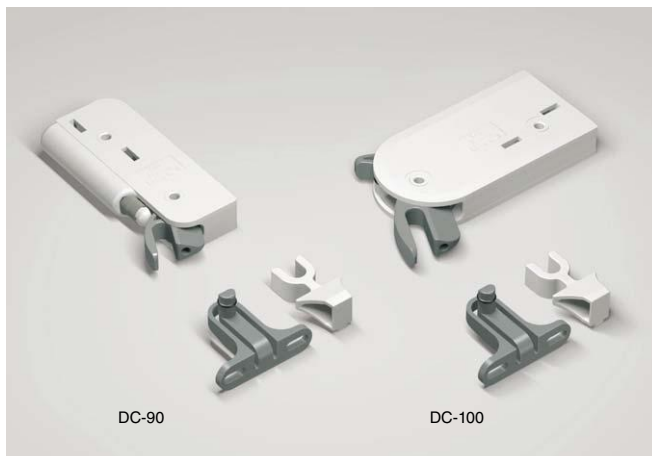

- Keeps cabinet doors from slamming shut.
- Holds the door in closed position.
- Available for wood and glass doors.
- Non Handed.
- Separate models for wood and glass doors.

### Face Plate for Glass Door Application

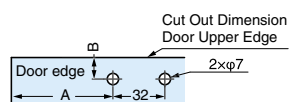
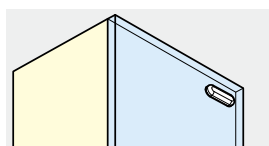
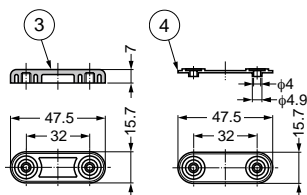

### Installation

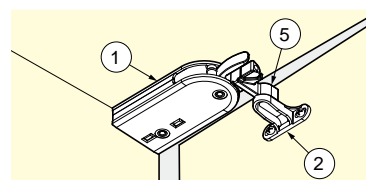
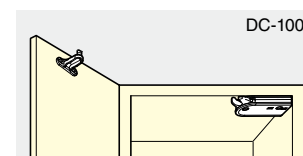
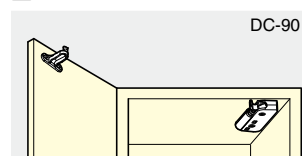

### DC-90

Installation Position	A	B
Inset Door	C - G <sub>1</sub> + 3	24 - G <sub>2</sub>
Outset Door	C + Overlay + 3	Overlay + 24

### DC-100

Installation Position	A	B
Inset Door	88 - G <sub>1</sub>	24 - G <sub>2</sub>
Outset Door	Overlay + 88	Overlay + 24

G<sub>1</sub> is the gap between the door edge and the side board. G<sub>2</sub> is the gap between the edge of the door and the top board.

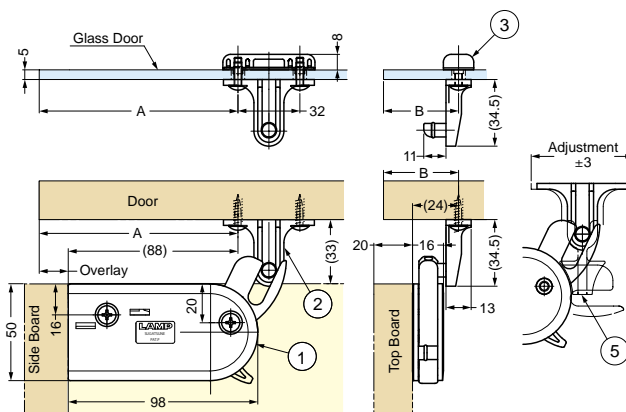
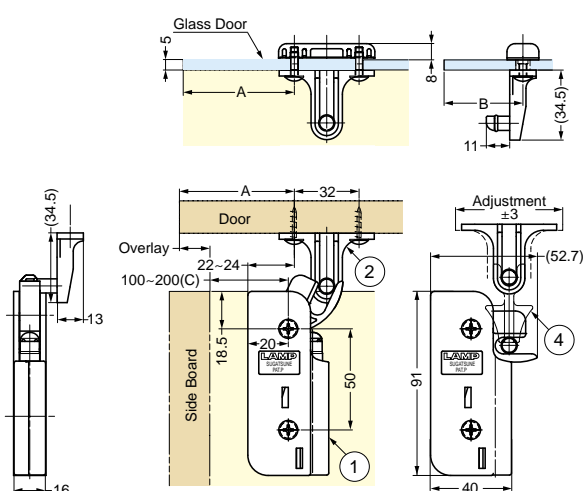

### Face Plate

Item Code	Item Name	Weight	Box
180-100-260	SDS-50G-CR	25 g	50pcs

No.	Part Name	Material	Finish/Color
①	Body	Polyacetal (POM)/PBT	Dark Grey /Light Grey
②	Trigger	Polyacetal (POM)	Dark Grey
③	Face Plate	Zinc Alloy (ZDC)	Chrome
④	Spacer	ABS	Black
⑤	Trigger Installation Jig	PBT	Light Grey

Item Code	Item Name	Spec.	Door Width	Door Height	Door Thickness	Door Weight	Weight	Box	Carton
140-021-697	DC-90	For Wooden Door	450	700	-	4kg	46 g	25	200pcs
140-021-698	DC-90G	For Glass Door	450	700	5	4kg	71 g	25	200pcs
140-021-699	DC-100	For Wooden Door	600	900	-	7kg	66 g	25	200pcs
140-021-700	DC-100G	For Glass Door	600	900	5	7kg	91 g	25	200pcs

# QUICK RELEASE LATCH



# SX-48



- Snap-in installation.
- Automatically latches when the panel is closed.
- Release multiple latches simultaneously with temporary hold-open feature.  
(No need to hold finger on latch when releasing)
- All components are plastic and 304 stainless steel to provide high corrosion resistance.
- UL94V-2 rated flame retardant material.

### Use Multiple Latches

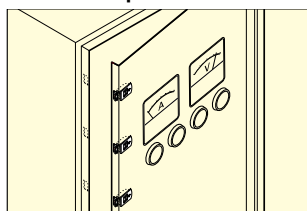

### Snap Into Panel

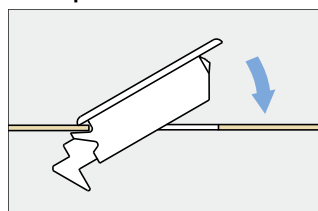

### Cut Out Dimensions

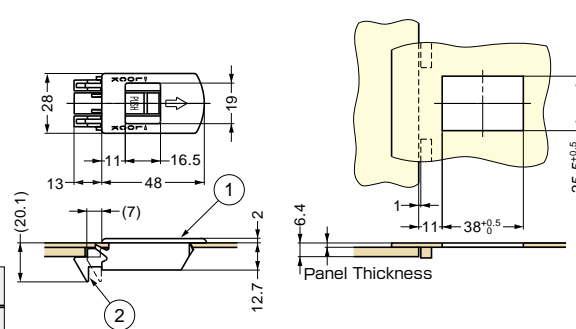

### Operation

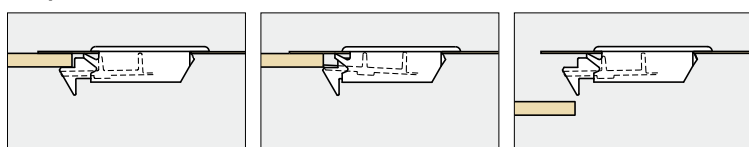

Locks when panel is closed.

**Hold-Open Feature**  
Each latch will hold in an opened position allowing user to release multiple latches at the same time.

Lever & latch is reset when the panel opens.

No.	Part Name	Material	Finish
①	Body	Polyamide (UL94V-0)	Silver
②	Latch	Polyacetal (UL94HB)	Silver
-	Spring	Stainless Steel (SUS304)	-

Item Code	Item Name	Panel Thickness	Color	Retaining Force (pc)	Weight	Box	Carton
140-050-037	SX-48	0.8,1.0,1.2,1.6,2.0,2.3	Black	49N	5kg	11g	40pcs 400pcs

# QUICK RELEASE LATCH WITH LOCKING

# LC-PK32

### Operation

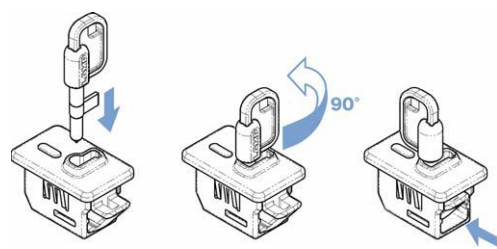

- Keylocking style restricts access.
- Single-hole, snap-in installation.
- UL94-VO rated flame retardant material.
- Non-corrosive materials.
- Key is removable in locked position only.

### Installation

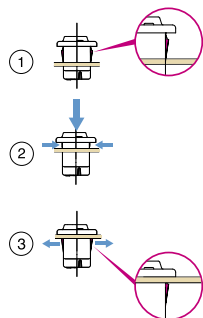

### Latch Body

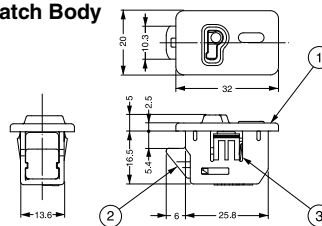

### Key

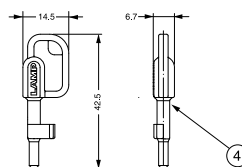

### Cut Out Dimensions

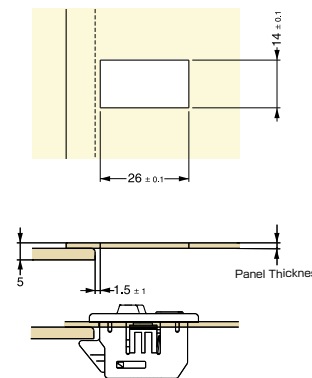

### Latch Body

Item Code	Item Name	Color	Door Thickness	Weight	Box	Carton
140-020-694	LC-PK32-L-BL	Black	1.2,1.5,1.6	6g	72pcs	720pcs
140-020-695	LC-PK32-L-GR	Grey	1.2,1.5,1.6	6g	72pcs	720pcs

### Key (Sold Separately)

Item Code	Item Name	Finish	Weight	Box	Carton
140-020-696	LC-PK32-K	Nickel	7g	200pcs	2000pcs

No.	Part Name	Material
①	Body	Polypropylene
②	Latch	PBT
③	Spring	Stainless Steel (SUS304)
④	Key	Zinc Alloy

# PANEL LATCH With Locking

# LC-PK32

Compact locking panel latch, yet full of innovations.

**NEW!**

**RoHS**



Color variations: Black, Grey



4 Major highlights. Add up to efficiency & security!

**1**

Easy latching & removal of panels

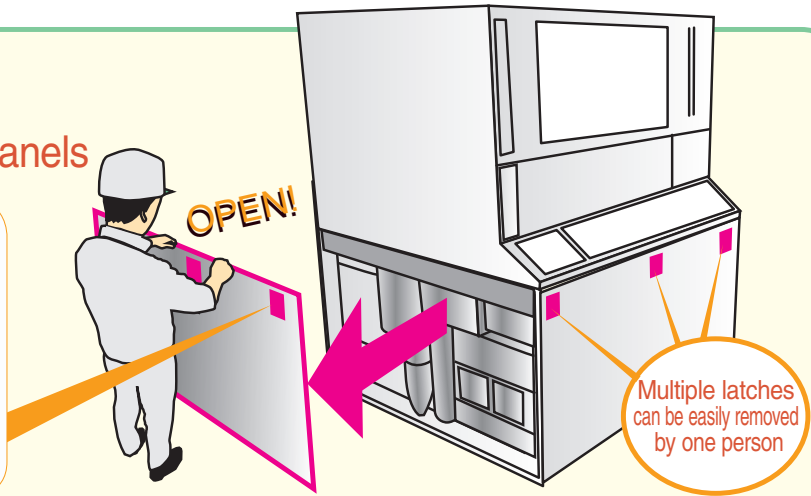
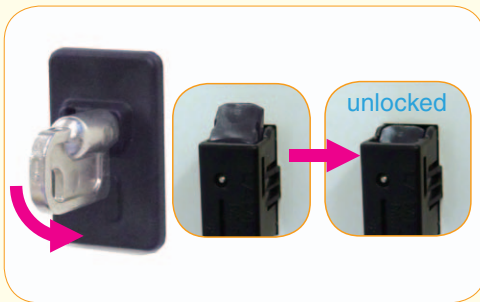

**2**

One touch installation

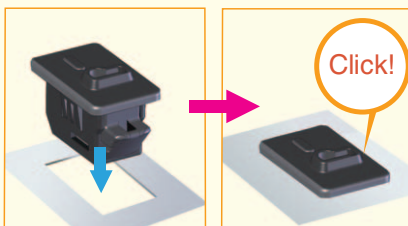

**3**

Comes with locking function



**4**

UL94-V0 rated flame retardant material

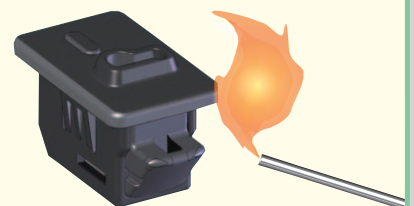

# SLIDING DOOR LATCH

# HC-30R



- Slim design suitable for various applications.
- Non-Handed: Can be installed on left or right side.
- For door thickness 28 ~ 52mm.

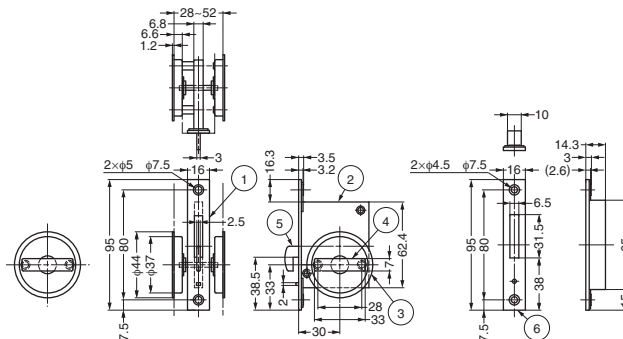

### Installation

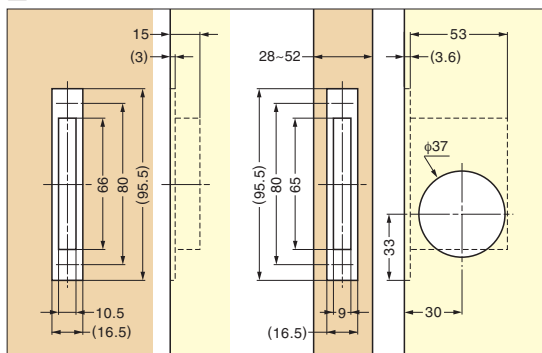

No.	Part Name	Material	Finish
①	Front plate	304 Stainless Steel	Hairline Finish
②	Body	Steel	Galvanized Steel Plate
③	Thumbturn body	304 Stainless Steel	Polished
④	Thumbturn	Zinc Alloy	Chrome Plating
⑤	Cam	304 Stainless Steel	Barrel Polish
⑥	Mounting plate	304 Stainless Steel	Hairline Finish

Item Code	Item Name	Box (pcs)	Carton (pcs)
140-022-282	HC-30R	5	50

# SLIDING DOOR LATCH



# HC-30

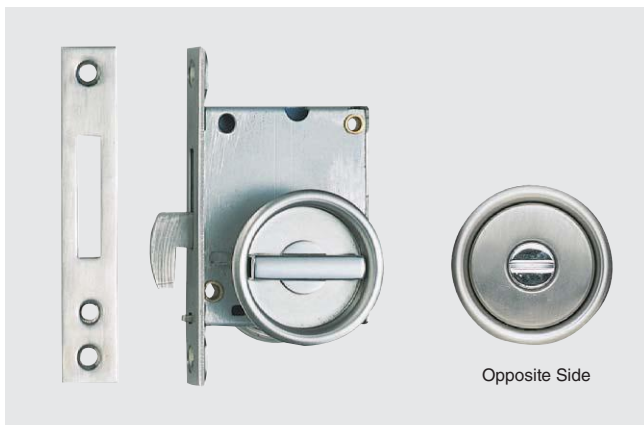

- Slim design suitable for various applications.
- Non-Handed: Can be installed on left or right side.
- For door thickness 28 ~ 40mm.
- For sliding doors only.

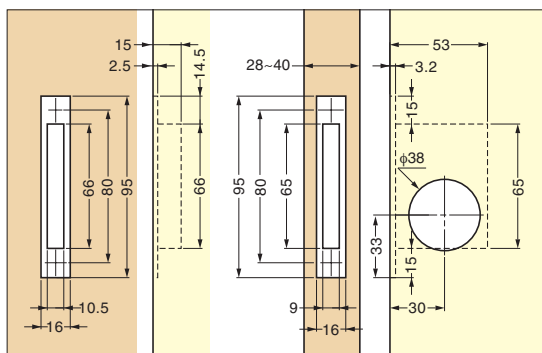
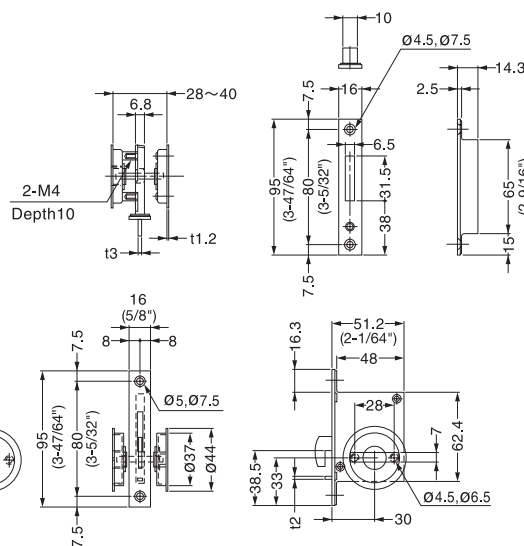

Bore Dimensions

Item Code	Item Name	Box (pcs)	Carton (pcs)	Material	Finish
140-183-251	HC-30	5	50	304 Stainless Steel, Brass, Zinc Alloy	Satin

# SLIDING DOOR LATCH W/INDICATOR



## HC-30H

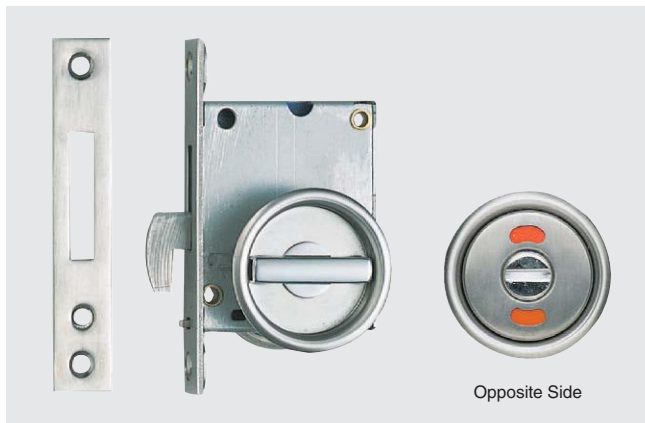

- Door latch with indicator.
- Slim design suitable for various applications.
- Non-Handed: Can be installed on left or right side.
- For door thickness 28 ~ 40mm.
- For sliding doors only.

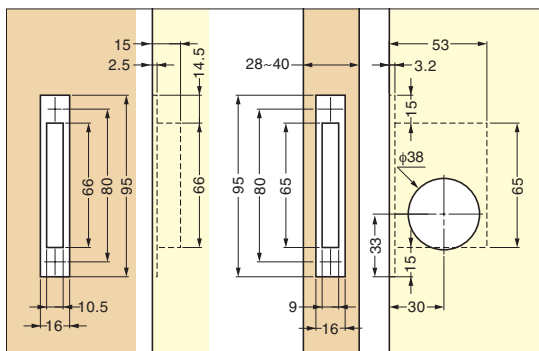
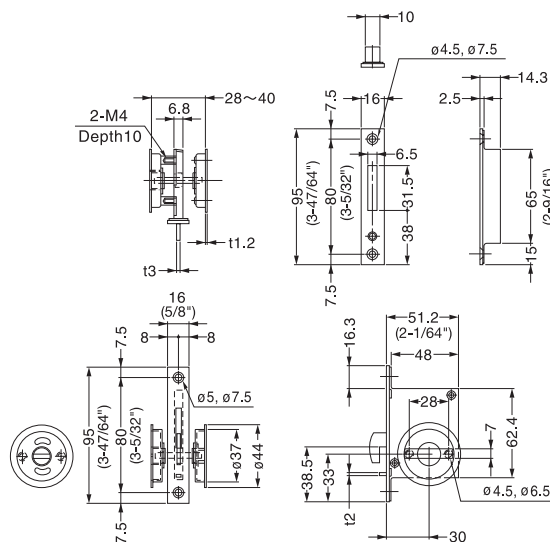

Bore Dimensions

Item Code	Item Name	Box (pcs)	Carton (pcs)	Material	Finish
140-183-250	HC-30H	5	50	304 Stainless Steel, Brass, Zinc Alloy	50

# SLIDING DOOR LATCH



## HC-70



- Sliding Door latch for surface mount installation.
- Slide knob to lock and unlock.
- Large knob for easy operation.
- Non-Handed: Can be installed on left or right side.
- Slim design suitable for various applications.

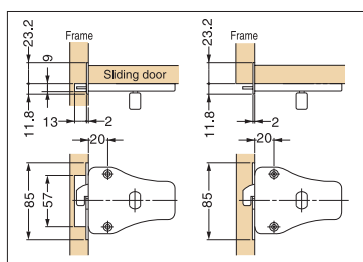
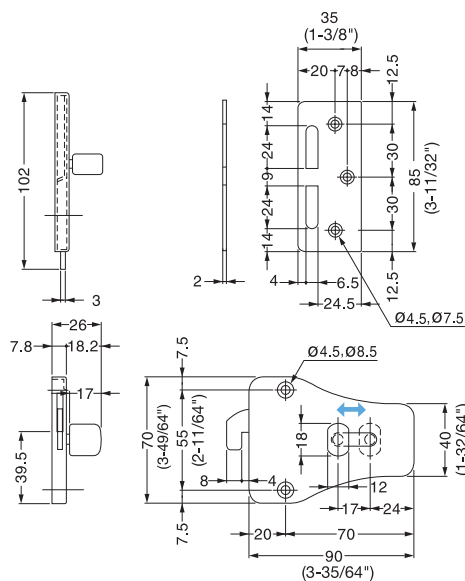

Installation

Item Code	Item Name	Weight (g)	Box (pcs)	Carton (pcs)	Material	Finish
140-183-255	HC-70	197	5	50	304 Stainless Steel, Brass	Satin

# SLIDING DOOR LATCH W/INDICATOR



## HC-70H



- Sliding Door latch with indicator and large knob.
- Slide knob to lock and unlock.
- Slim design suitable for various application.
- Large knob for easy operation.
- Non-Handed: Can be installed on left or right side.
- For door thickness 26 ~ 40mm.

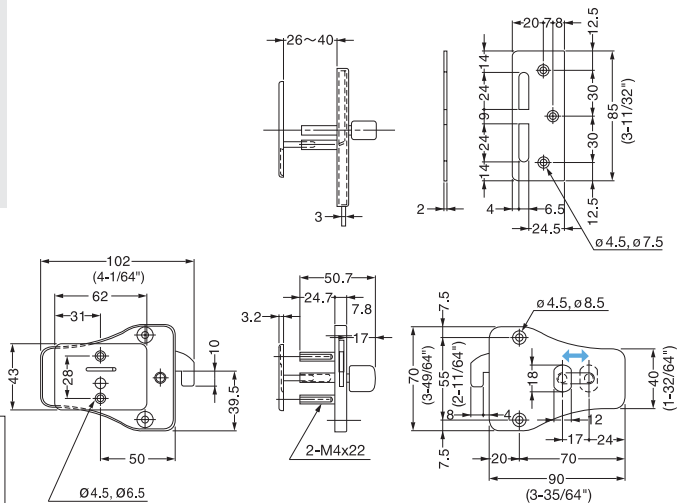
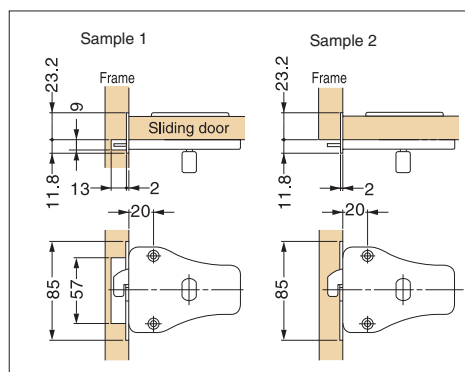

Installation

Bore Dimensions

Item Code	Item Name	Weight (g)	Box (pcs)	Carton (pcs)	Material	Finish
140-183-254	HC-70H	297	5	50	304 Stainless Steel, Brass	Satin

# SLIDING DOOR LATCH



## HC-30L

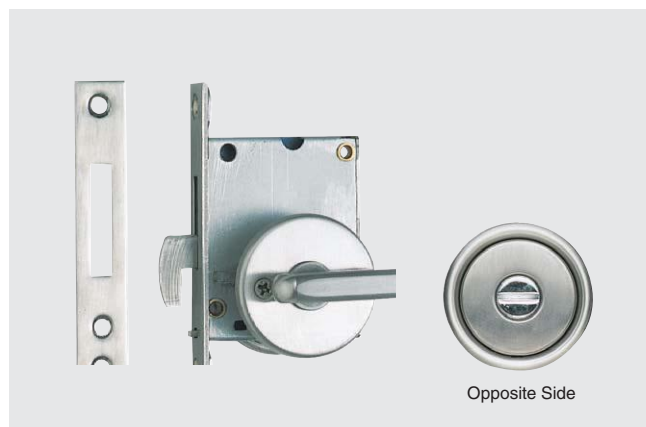

- Sliding Door latch with large lever for easy operation.
- Slim design suitable for various applications.
- Non-Handed: Can be installed on left or right side.
- For door thickness 28 ~ 40mm.

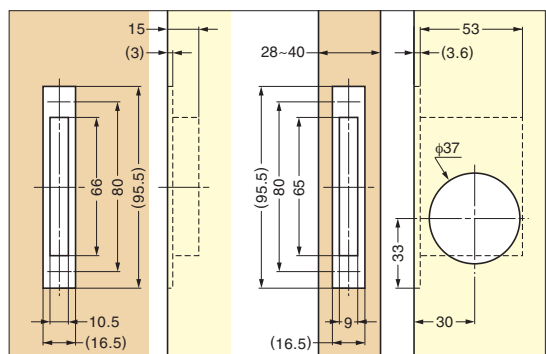

Bore Dimensions

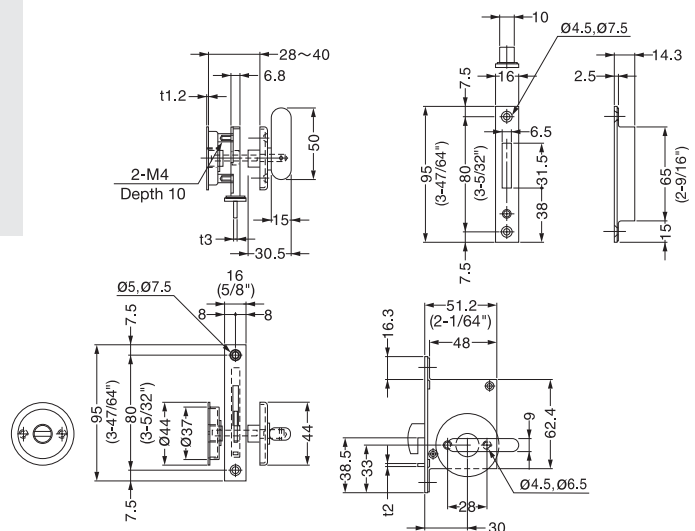

Item Code	Item Name	Box (pcs)	Carton (pcs)	Material	Finish
140-183-253	HC-30L	5	50	304 Stainless Steel, Brass, Zinc Alloy	Satin



# SLIDING DOOR LATCH W/INDICATOR



## HC-30HL



- Sliding Door latch with indicator.
- Large lever for easy operation.
- Slim design suitable for various applications.
- Non-Handed: Can be installed on left or right side.
- For door thickness 28 ~ 40mm.

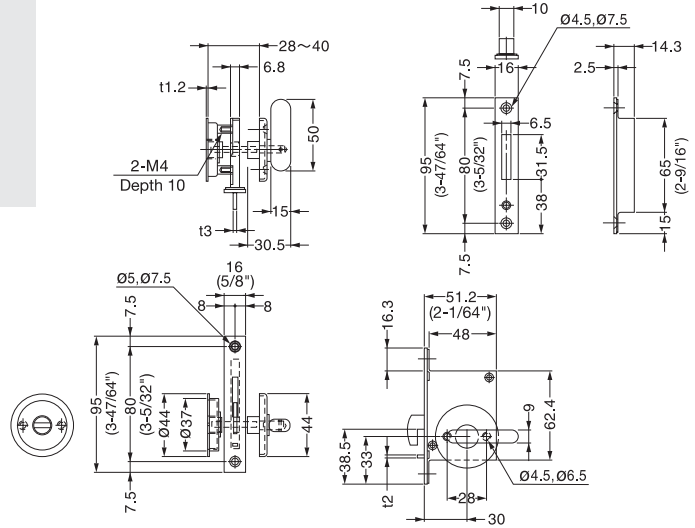
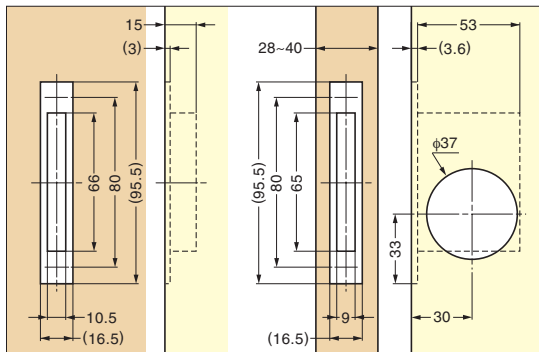

Item Code	Item Name	Box (pcs)	Carton (pcs)	Material	Finish
140-183-252	HC-30HL	5	50	304 Stainless Steel, Brass, Zinc Alloy	Satin

# SLIDING DOOR LATCH



## HC-65



- Surface mount type door latch with noticeable indicator.
- Extra slim and compact design.
- Simply slide up and down the knob to lock / unlock.
- Non-Handed: Can be installed on left or right side.

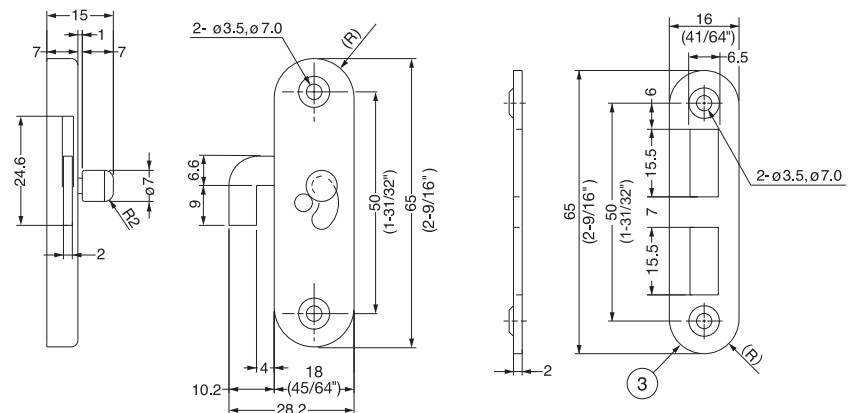
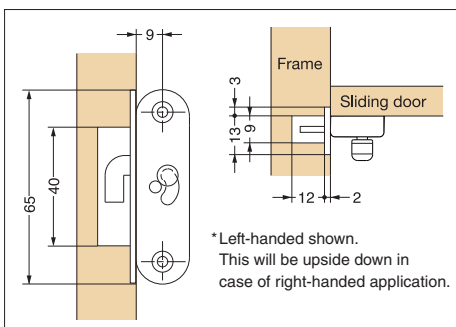

Item Code	Item Name	Weight (g)	Box (pcs)	Carton (pcs)	Material	Finish
140-180-578	HC-65	41	20	200	304 Stainless Steel, Brass	Satin

# SLIDING DOOR LATCH



## HHC-85

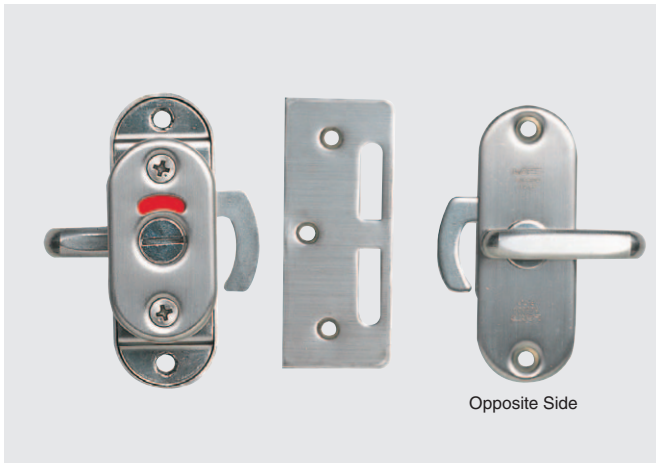

- Sliding Door latch with indicator.
- Slim design suitable for various applications.
- Large lever for easy operation.
- Non-Handed: Can be installed on left or right side.
- For door thickness 26 ~ 38mm.

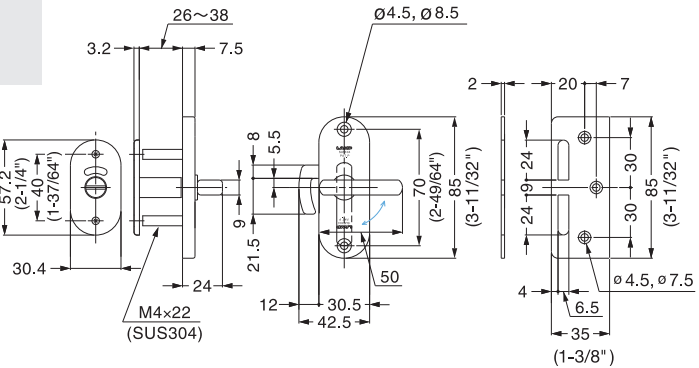
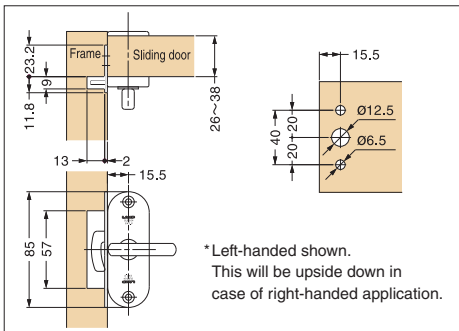

Installation

Item Code	Item Name	Weight (g)	Box (pcs)	Carton (pcs)	Material	Finish
140-180-000	HHC-85	120	6	30	304 Stainless Steel, Brass	Satin

# SLIDING DOOR LATCH



## HC-85SS



- Surface mount type door latch with noticeable indicator.
- Simply slide up and down the knob to lock / unlock.
- Slim design suitable for various applications.
- Non-Handed: Can be installed on left or right side.

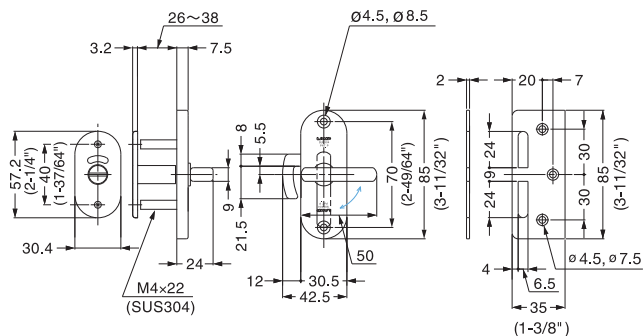
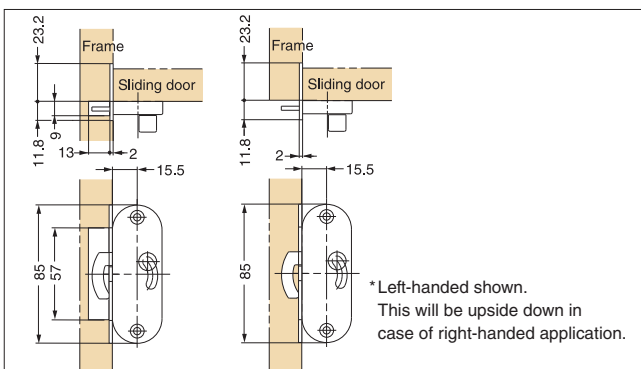

Installation

Item Code	Item Name	Weight (g)	Box (pcs)	Carton (pcs)	Material	Finish
140-170-774	HC-85SS	120	20	100	304 Stainless Steel, Brass	Satin

### SOFT-DOWN / LIFT-UP STAYS



### LID SUPPORTS

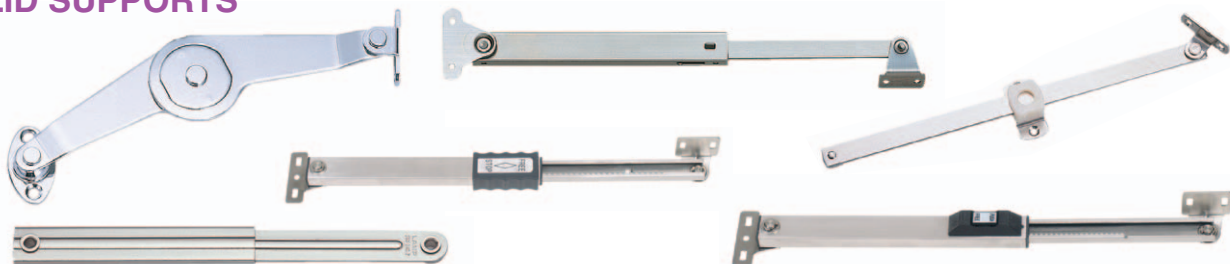

### DOOR HOLDERS

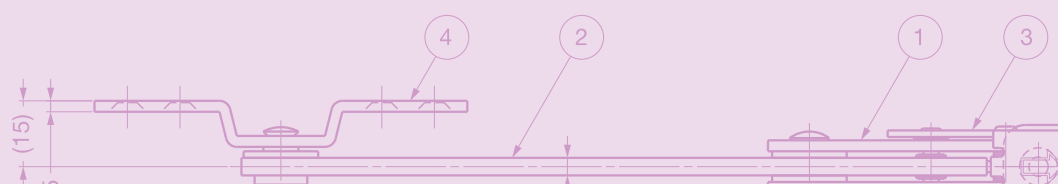
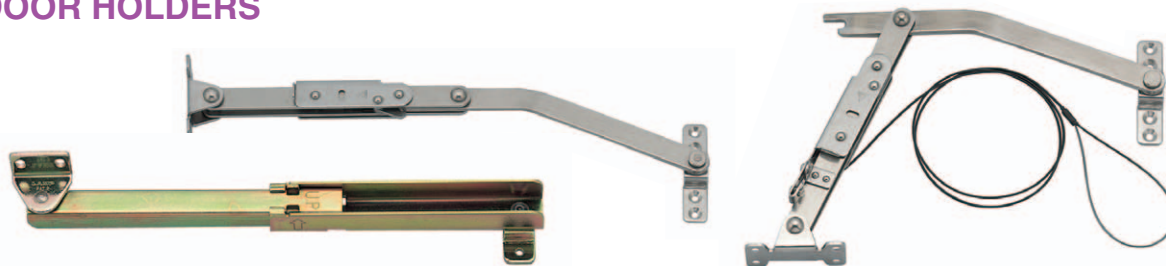

## LID SUPPORTS

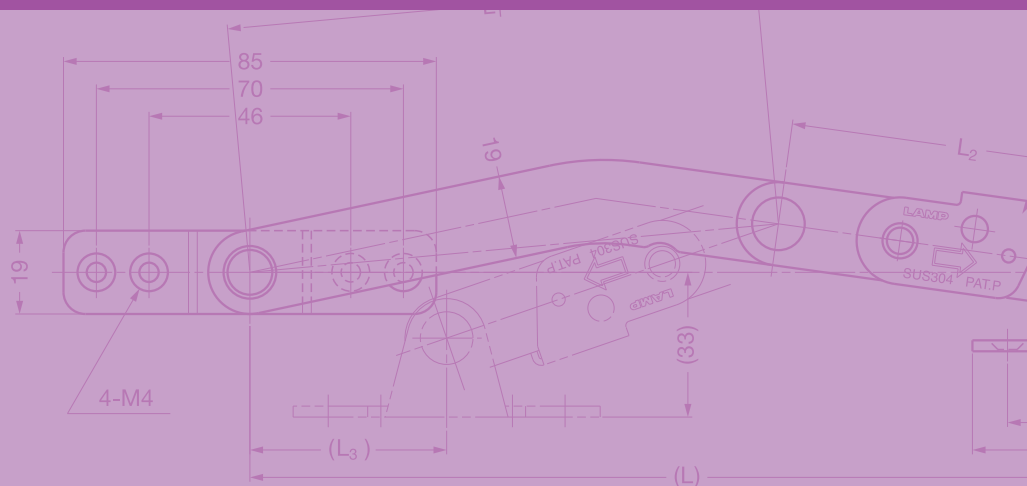

SOFT CLOSE / LIFT ASSIST STAYS

Picture	Item Name	Application	Page
	SLS-ELAN		110
	EZS-ELAN		112

Picture	Item Name	Application	Page
	SLU-ELAN		134
	SLD		135
	HBFN		137

SOFT CLOSING STAYS

Picture	Item Name	Application	Page
	SDS-100-TV/TVZ		115
	SDS-C100		116
	SDS-400-W		117
	SDS-C301N		118
	NSD-10		121
	NSD-20		122
	NSD-35		123
	NSDX-10(R/L)K/TV		124
	HDS-10		127
	HDS-20		128
	HDS-30		129
	HDSN-30		130
	SLUN-N		133

















































SPRING LOADED LIFT ASSIST STAYS

Picture	Item Name	Application	Page
	S-YT	<b>STAINLESS 304 STEEL</b>	138
	S-AT	<b>STAINLESS 430 STEEL</b>	139
	LK	<b>STAINLESS 304 STEEL</b>	140

TORQUE LID STAYS

Picture	Item Name	Application	Page
	S-100T30	<b>STAINLESS 430 STEEL</b>	141
	S-52T15	<b>STAINLESS 430 STEEL</b>	141

LID STAYS

Picture	Item Name	Application	Page	Picture	Item Name	Application	Page		
	L-100S, L-140S	 STAINLESS 304 STEEL		142		HS	 STAINLESS 304 STEEL		150
	L-S-BT	 STAINLESS 304 STEEL		142		SAD-160	 STAINLESS 304 STEEL	DOOR STAY	150
	L-SL140	 STAINLESS 304 STEEL		143		S-91, 92, 93	 STAINLESS 304 STEEL		150
	L-FS140	 STAINLESS 304 STEEL		143		F-300	 STAINLESS 304 STEEL		151
	L-200P	 STAINLESS 304 STEEL		143		F-150, 200, 250	 STAINLESS 304 STEEL		151
	L	 STAINLESS 304 STEEL		144		F-100	 STAINLESS 304 STEEL		151
	LSP	 STAINLESS 304 STEEL		144		S-23		152	
	LB	 STAINLESS 304 STEEL		145		S-21		152	
	LB-215, 290	 STAINLESS 304 STEEL		145		S-20		152	
	LB-S	 STAINLESS 304 STEEL		146		YF	FOOT STAY	153	
	LBTS	 STAINLESS 304 STEEL		146		YF-300W	FOOT STAY	153	
	LB-CV215A	 STAINLESS 304 STEEL		147		YA-2020	 STAINLESS 304 STEEL	DOOR HOLDER	154
	L-FS350A	 STAINLESS 304 STEEL		147		YA-0812, 1216	 STAINLESS 304 STEEL	DOOR HOLDER	155
<b>Discontinued</b> 	L-FSP350A			148					
<b>Discontinued</b> 	L-FSS350A			148					
	U-3005	 STAINLESS 304 STEEL	DOOR STAY	149					
	U-3031	 STAINLESS 304 STEEL		149					



= Soft & Smooth

Lapcon series products provide the smoothest opening and closing system imaginable, equipped with Sugatsune's built-in patented dampening device. As a Lapcon opens and closes, it moves with quiet assurance. Lapcon products also provide safety to your application with its revolutionary damper. Doors and lids will come down slowly and softly which eliminates slamming doors or smashed fingers.

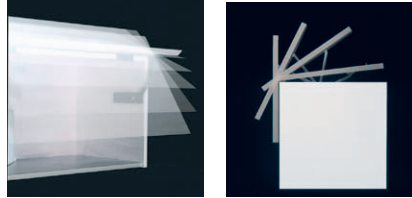

## Lapcon series

Variation		APPLICATION	HINGE	MODEL	OPENING ANGLE
	Downward		<ul style="list-style-type: none"> <li>Butt Hinge</li> <li>Drop Hinge</li> <li>Concealed Hinge</li> </ul>	SDS - 100TV, SDS - C100TV SDS - 100, SDS - C100 NSD - 10 HDS - 10	90°
	Top-Opening		<ul style="list-style-type: none"> <li>Butt Hinge</li> <li>Concealed Hinge</li> </ul>	SDS - C301N NSD - 20 HDS - 20	70° / 105° 70° / 105° 70°
	Upward		<ul style="list-style-type: none"> <li>Butt Hinge</li> <li>Concealed Hinge</li> </ul>	SDS - C301N NSD - 35 NSD - 35 HDS - 30 HDSN - 30 SLS-ELAN	80° / 90° / 100° 80° / 90° / 100° 80° / 90° / 100° 80° 80° / 90° 90°
	Downward Opening		<ul style="list-style-type: none"> <li>Butt Hinge</li> </ul>	EZS - ELAN SDS - 400 - W	70° 70°

### Other Unique Door Opening Solutions

#### BI-FOLDING STAY

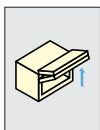

**HBFN**  
• Arm length adjustable

P.137

#### LIFT-UP STAY

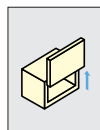

**SLUN-N/SLU-ELAN**  
• Swing out vertically in a small radius

P.132-  
P.134

#### LIFT ASSIST STAY

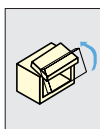

**EZS-ELAN**  
• Large door lift semi up-over  
• No connecting bar, no hinge required

P.112

#### LIFT-DOWN STAY

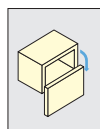

**SLD**  
• Swing out vertically in a small radius

P.135

Door weight ranges

■ SDS

Door Height	SDS-100-TV/SDS-C100-TV		SDS-100-TVZ/SDS-C100-TVZ		SDS-100/SDS-C100/SDS-400		SDS-C301N	
	Door Weight/piece	Door Weight/piece	Door Weight/piece	Door Weight/piece	Door Weight/piece	Door Weight/piece	Door Weight/piece	Door Weight/piece
200	0.50 ~ 1.20 kg	1.00 ~ 2.40 kg	1.65 ~ 3.76 kg	3.30 ~ 7.52 kg	—	—	—	—
250	0.40 ~ 0.96 kg	0.80 ~ 1.92 kg	1.32 ~ 3.01 kg	2.64 ~ 6.02 kg	2.80 ~ 4.00 kg	5.60 ~ 8.00 kg	3.20 ~ 5.60 kg	6.40 ~ 11.20 kg
300	0.34 ~ 0.80 kg	0.67 ~ 1.60 kg	1.10 ~ 2.51 kg	2.20 ~ 5.01 kg	2.34 ~ 3.33 kg	4.67 ~ 6.66 kg	2.67 ~ 4.66 kg	5.34 ~ 9.33 kg
350	0.29 ~ 0.68 kg	0.58 ~ 1.37 kg	0.94 ~ 2.15 kg	1.89 ~ 4.30 kg	2.00 ~ 2.85 kg	4.00 ~ 5.71 kg	2.29 ~ 4.00 kg	4.58 ~ 8.00 kg
400	0.25 ~ 0.60 kg	0.50 ~ 1.20 kg	0.83 ~ 1.88 kg	1.65 ~ 3.76 kg	1.75 ~ 2.50 kg	3.50 ~ 5.00 kg	2.00 ~ 3.50 kg	4.00 ~ 7.00 kg
450	0.23 ~ 0.53 kg	0.45 ~ 1.06 kg	0.73 ~ 1.67 kg	1.47 ~ 3.34 kg	1.56 ~ 2.22 kg	3.12 ~ 4.44 kg	1.78 ~ 3.11 kg	3.56 ~ 6.22 kg
500	—	—	0.66 ~ 1.50 kg	1.32 ~ 3.01 kg	1.40 ~ 2.00 kg	2.80 ~ 4.00 kg	1.60 ~ 2.80 kg	3.20 ~ 5.60 kg

■ NSD

Door Height	NSD-10 (R/L) NSD-20 (R/L) NSD-35 (R/L)		NSDX-10 (R/L) K-TV	
	Door Weight/piece	Door Weight/piece	Door Weight/piece	Door Weight/pair
250	1.60 ~ 5.60 kg	3.20 ~ 11.20 kg	0.80 ~ 1.60 kg	1.60 ~ 3.20 kg
300	1.34 ~ 4.66 kg	2.67 ~ 9.33 kg	0.60 ~ 1.30 kg	1.20 ~ 2.60 kg
350	1.15 ~ 4.00 kg	2.29 ~ 8.00 kg	0.57 ~ 1.10 kg	1.14 ~ 2.20 kg
400	1.00 ~ 3.50 kg	2.00 ~ 7.00 kg	0.50 ~ 1.00 kg	1.00 ~ 2.00 kg
450	0.89 ~ 3.11 kg	1.78 ~ 6.22 kg	0.44 ~ 0.88 kg	0.88 ~ 1.76 kg
500	0.80 ~ 2.80 kg	1.60 ~ 5.60 kg	0.40 ~ 0.80 kg	0.80 ~ 1.60 kg

■ HDS

Door Height	HDS-10K HDS-20K HDS-30K	HDS-10M HDS-20M HDS-30M	HDS-10H HDS-20H HDS-30H
	Door Weight/piece	Door Weight/piece	Door Weight/piece
300	9.34 ~ 13.33 kg	13.34 ~ 16.66 kg	16.67 ~ 20.00 kg
350	8.00 ~ 11.42 kg	11.43 ~ 14.28 kg	14.29 ~ 17.14 kg
400	7.00 ~ 9.99 kg	10.00 ~ 12.49 kg	12.50 ~ 15.00 kg
450	6.23 ~ 8.88 kg	8.89 ~ 11.11 kg	11.12 ~ 13.33 kg
500	5.60 ~ 7.99 kg	8.00 ~ 9.99 kg	10.00 ~ 12.00 kg
550	5.1 ~ 7.27 kg	7.28 ~ 9.09 kg	9.10 ~ 10.90 kg
600	4.67 ~ 6.66 kg	6.67 ~ 8.33 kg	8.34 ~ 10.00 kg

■ HDSN

Door Height	Opening angle 90°				Opening angle 80°			
	HDSN-30K	HDSN-30M	HDSN-30H	HDSN-30S	HDSN-30K	HDSN-30M	HDSN-30H	HDSN-30S
	Door Weight/pair	Door Weight/pair	Door Weight/pair	Door Weight/pair	Door Weight/pair	Door Weight/pair	Door Weight/pair	Door Weight/pair
250	11.20 ~ 15.19 kg	15.20 ~ 18.39 kg	18.40 ~ 21.59 kg	21.60 ~ 24.00 kg	—	—	—	—
300	9.33 ~ 12.66 kg	12.67 ~ 15.32 kg	15.33 ~ 17.99 kg	18.00 ~ 20.00 kg	—	—	—	—
350	8.00 ~ 10.85 kg	10.86 ~ 13.13 kg	13.14 ~ 15.42 kg	15.43 ~ 17.14 kg	8.00 ~ 11.42 kg	11.43 ~ 14.28 kg	14.29 ~ 17.13 kg	17.14 ~ 20.00 kg
400	7.00 ~ 9.49 kg	9.50 ~ 11.49 kg	11.50 ~ 13.49 kg	13.50 ~ 15.00 kg	7.00 ~ 9.99 kg	10.00 ~ 12.49 kg	12.50 ~ 14.99 kg	15.00 ~ 17.50 kg
450	6.22 ~ 8.43 kg	8.44 ~ 10.21 kg	10.22 ~ 11.99 kg	12.00 ~ 13.33 kg	6.22 ~ 8.88 kg	8.89 ~ 11.10 kg	11.11 ~ 13.32 kg	13.33 ~ 15.56 kg
500	5.60 ~ 7.59 kg	7.60 ~ 9.19 kg	9.20 ~ 10.79 kg	10.80 ~ 12.00 kg	5.60 ~ 7.99 kg	8.00 ~ 9.99 kg	10.00 ~ 11.99 kg	12.00 ~ 14.00 kg
550	5.09 ~ 6.90 kg	6.91 ~ 8.35 kg	8.36 ~ 9.81 kg	9.82 ~ 10.91 kg	5.09 ~ 7.26 kg	7.27 ~ 9.08 kg	9.09 ~ 10.90 kg	10.91 ~ 12.73 kg
600	4.67 ~ 6.32 kg	6.33 ~ 7.66 kg	7.67 ~ 8.99 kg	9.00 ~ 10.00 kg	4.67 ~ 6.66 kg	6.67 ~ 8.33 kg	8.33 ~ 9.99 kg	10.00 ~ 11.67 kg

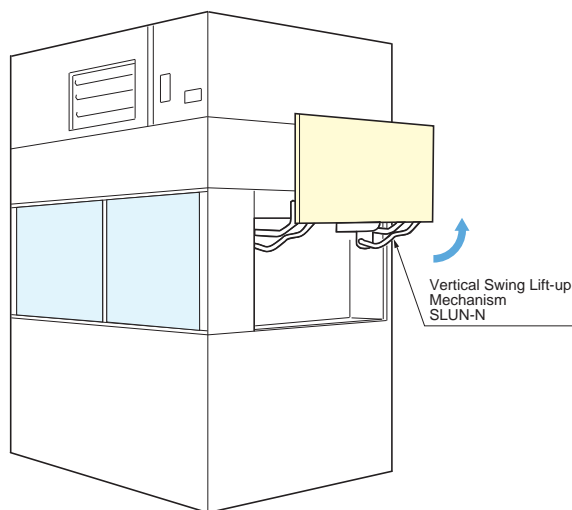
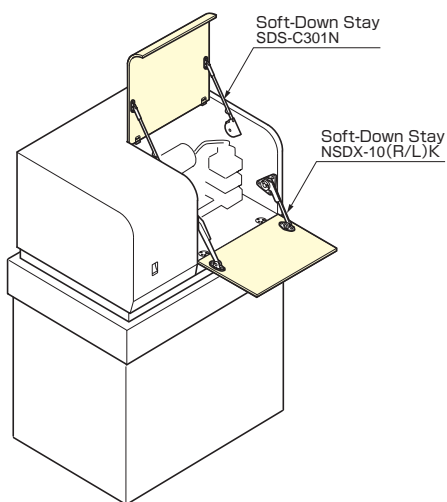

# EASY LIFT-UP STAY



# SLS-ELAN



- For Up Upward-Opening Flap Doors with concealed, piano, butt, or drop hinges.
- Designed to provide effortless opening and hold door in closed and opened position.
- Offers smooth and soft downward movement preventing lids or doors from slamming shut.
- Easy to install by aligning the body to the edge of cabinet.
- Free stop from 30° to 90° .
- Single or pair use allows wide range of door size/ weights.
- 2 Powers available (M,H).
- Successfully passed 40,000 open/close cycle test.

Designed to operate at room temperature 0° ~40° C

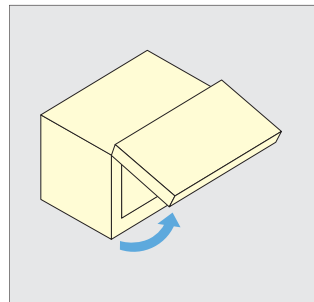
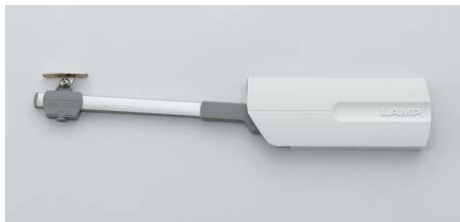

### 3 functions on 1 stay

#### 1. Lift-assist



#### 2. Free stop



#### 3. Soft-close

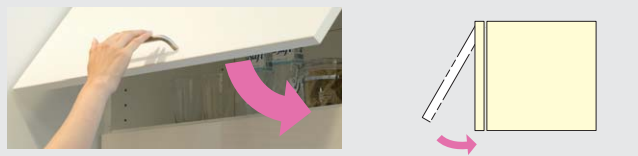

### Door Size Ranges

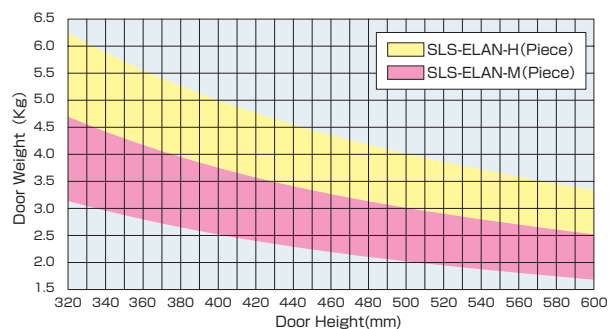

For heavier flap application, please contact your local dealer or Sugatsune office.

### Easy Installation

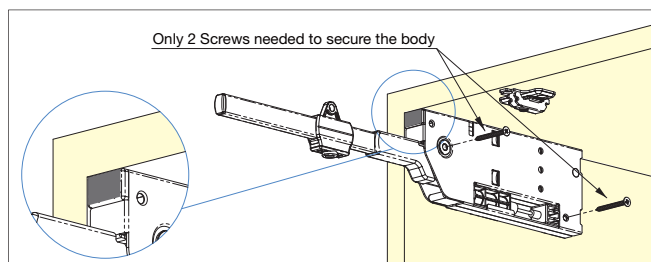

### Adjustment

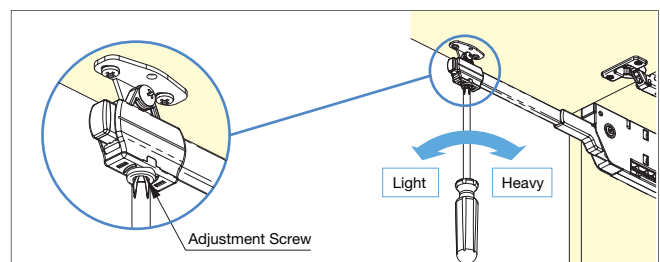



Installation

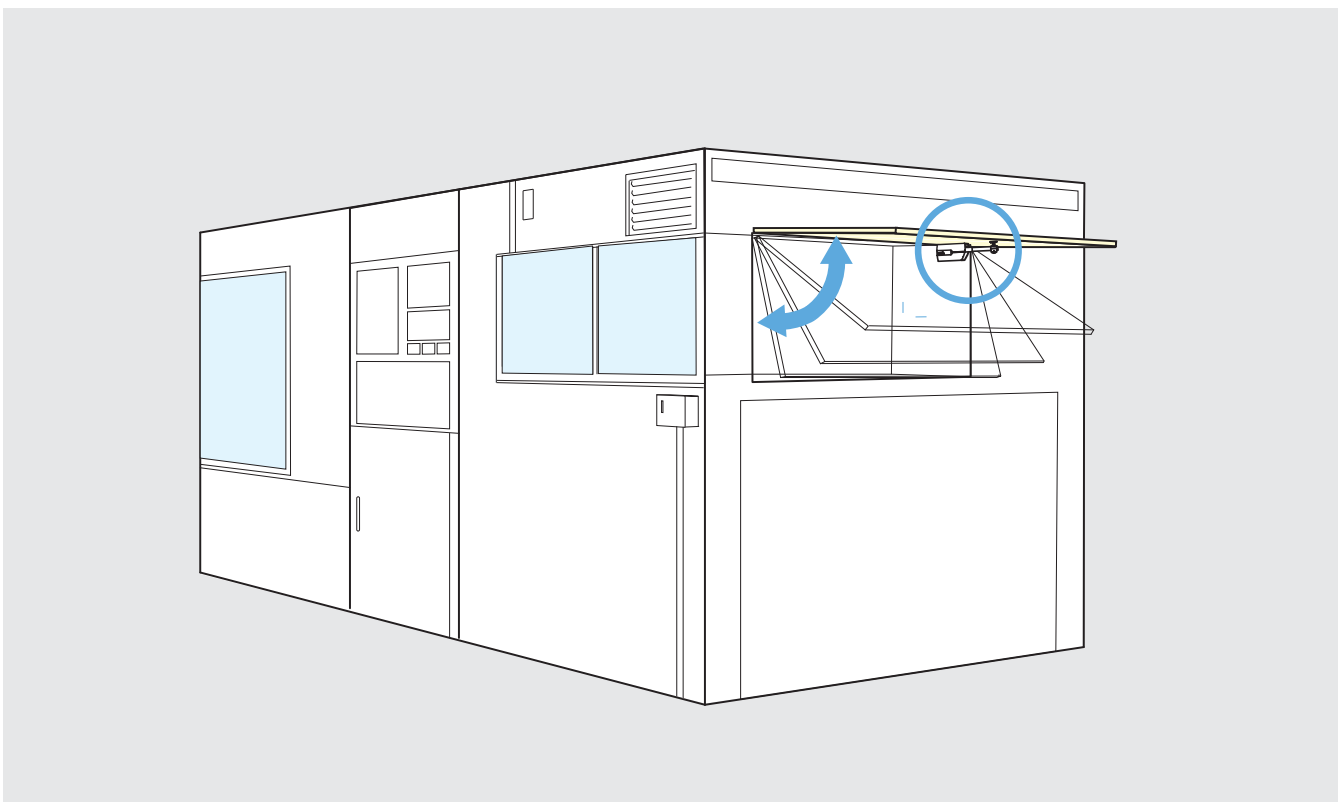
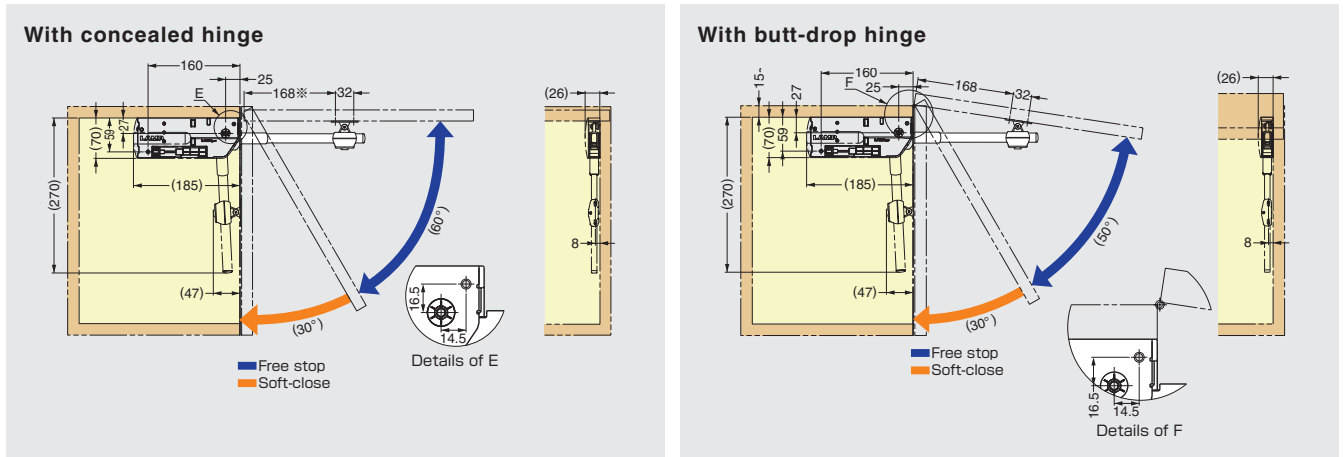

Item Code	Item Name	Spec.	Material	Finish/Color	Weight	Model	Torque per piece N · m	Torque per piece kgf · cm	Carton
180-015-491	SLS-ELAN-MR	Right	Aluminum Alloy/ABS	Anodized/Light Grey	600g	M	4.90 N · m ~ 7.35 N · m	50 kgf · cm ~ 75 kgf · cm	20pcs
180-015-490	SLS-ELAN-ML	Left	Aluminum Alloy/ABS	Anodized/Light Grey	600g	M	4.90 N · m ~ 7.35 N · m	50 kgf · cm ~ 75 kgf · cm	20pcs
180-015-493	SLS-ELAN-HR	Right	Aluminum Alloy/ABS	Anodized/Light Grey	600g	H	7.35 N · m ~ 9.80 N · m	75 kgf · cm ~ 100 kgf · cm	20pcs
180-015-492	SLS-ELAN-HL	Left	Aluminum Alloy/ABS	Anodized/Light Grey	600g	H	7.35 N · m ~ 9.80 N · m	75 kgf · cm ~ 100 kgf · cm	20pcs

# LIFT ASSIST STAY



# EZS-ELAN



- For Up & Over the Cabinet Opening Flap Doors.
- Lift assist function for easy and smooth opening.
- Soft-closing function for silent and safe closing.
- Free stop function from 30°-70° .
- Easy to install by aligning the body to the edge of cabinet.
- No hinges required.
- No connecting bar required.
- Clip-on mounting plate for speedy door installation.
- 3 Powers available (L,M,H).
- Successfully passed 30,000 open/close cycle test.

Designed to operate at room temperature 0°-40°C

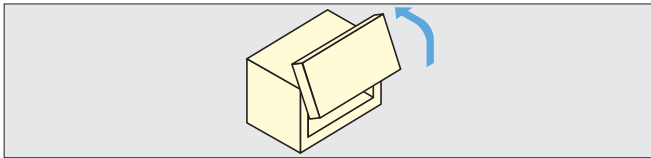
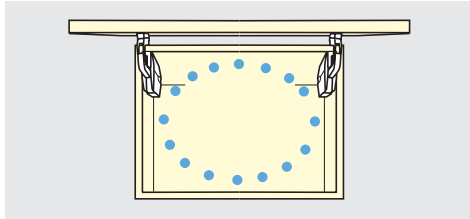

### 3 functions on 1 stay

#### 1. Lift-assist



#### 2. Free stop

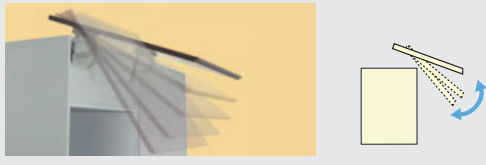

#### 3. Soft close

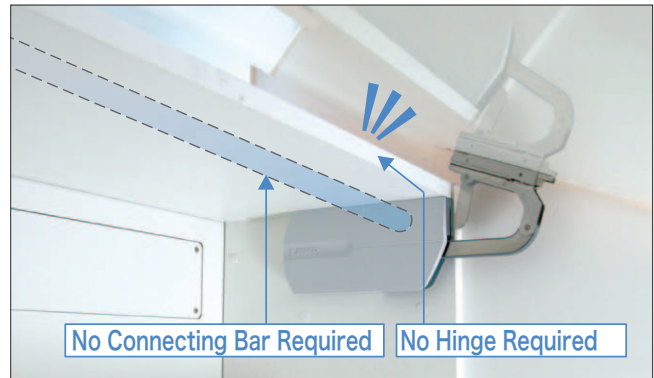
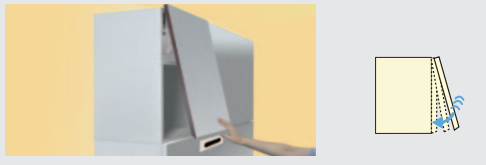

### Easy Install

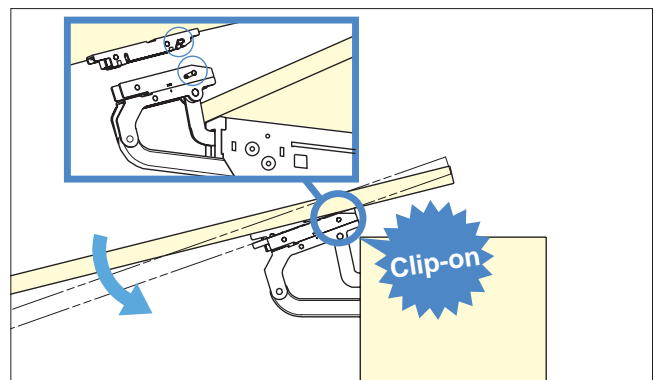
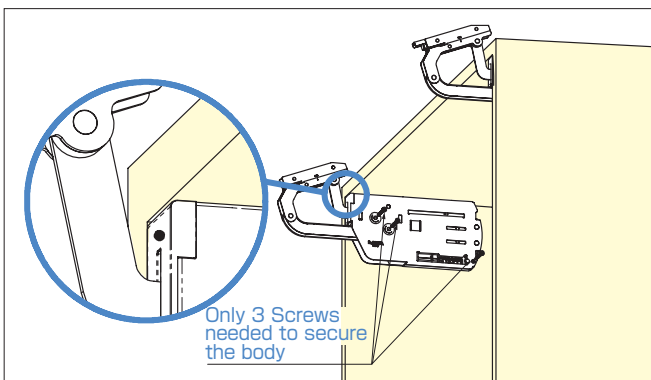

# LIFT ASSIST STAY

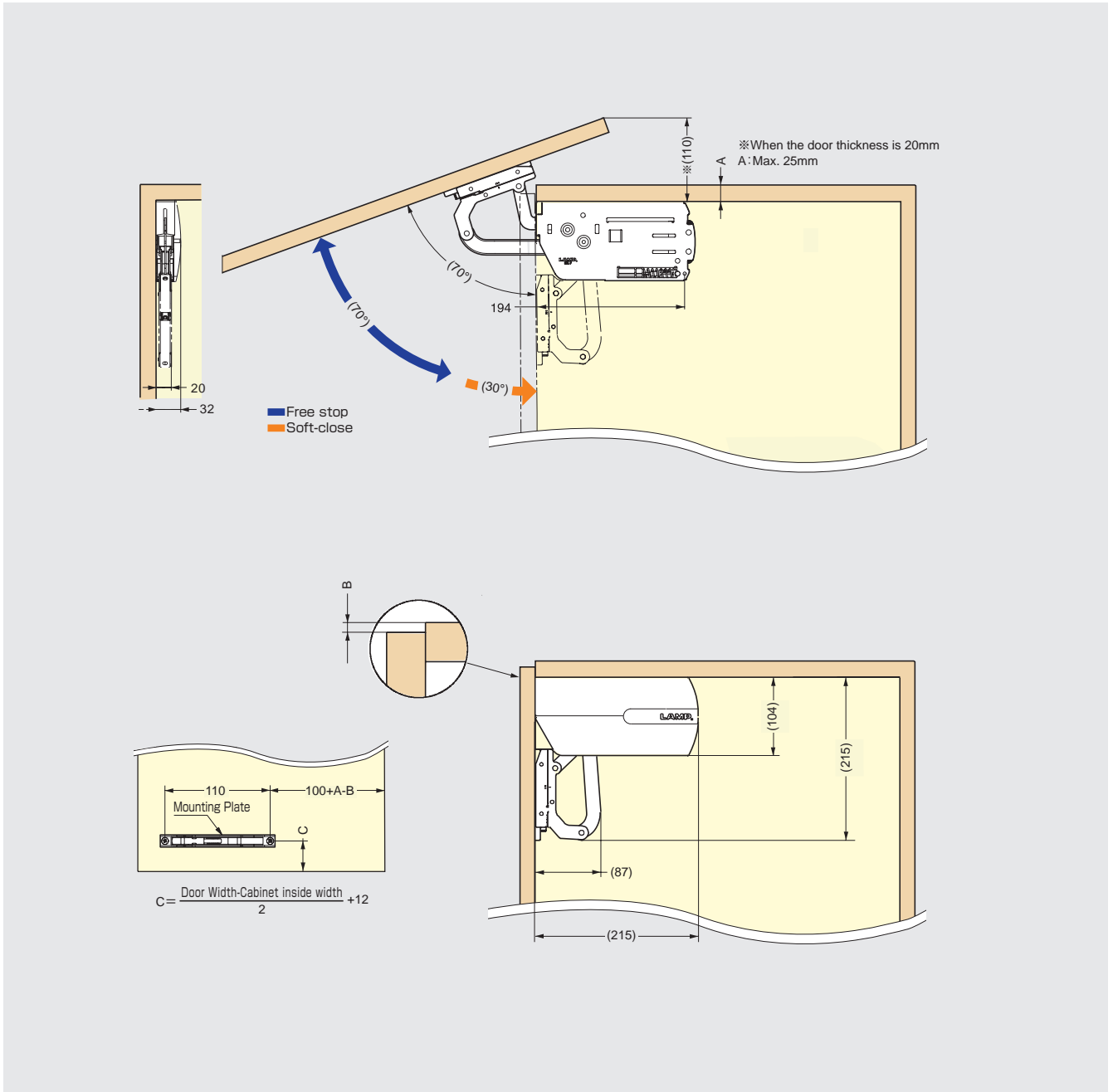

## Door Size Ranges

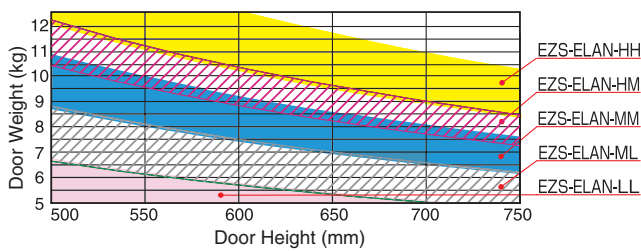

Lifting Power	Model
1900 ~ 2860	EZS-ELAN-L L
2820 ~ 3900	EZS-ELAN-M L
3850 ~ 4950	EZS-ELAN-MM
4700 ~ 5600	EZS-ELAN-HM
5550 ~ 6930	EZS-ELAN-HH

※ Lifting Power = Door Height(mm) × (Door Weight(kg)-1)

Item Code	Item Name	Material	Finish/Color	Weight	Carton
180-018-903	EZS-ELAN-LL	Steel/ABS	Nickel/Light Grey	2245g	5sets
180-018-904	EZS-ELAN-ML	Steel/ABS	Nickel/Light Grey	2262g	5sets
180-018-905	EZS-ELAN-MM	Steel/ABS	Nickel/Light Grey	2350g	5sets
180-018-906	EZS-ELAN-HM	Steel/ABS	Nickel/Light Grey	2431g	5sets
180-018-907	EZS-ELAN-HH	Steel/ABS	Nickel/Light Grey	2475g	5sets

# SDS

## SOFT-DOWN STAY



- One-way rotary damper offers smooth and soft downward movement preventing lids or doors from slamming shut.
- Compact design.
- Easy Installation.
- Successfully passed for 40,000 open/close private cycle tests.

Designed to operate at room temperature 0°~40°C (32°~104°F).

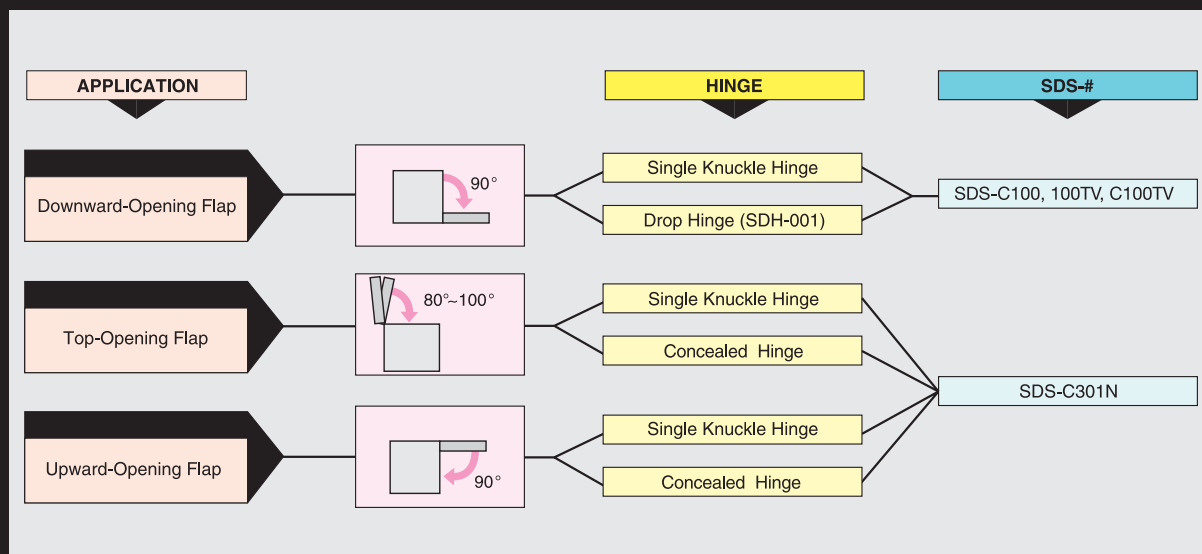

SOFT-DOWN STAY (SHORT-ARM)



SDS-100-TV/TVZ

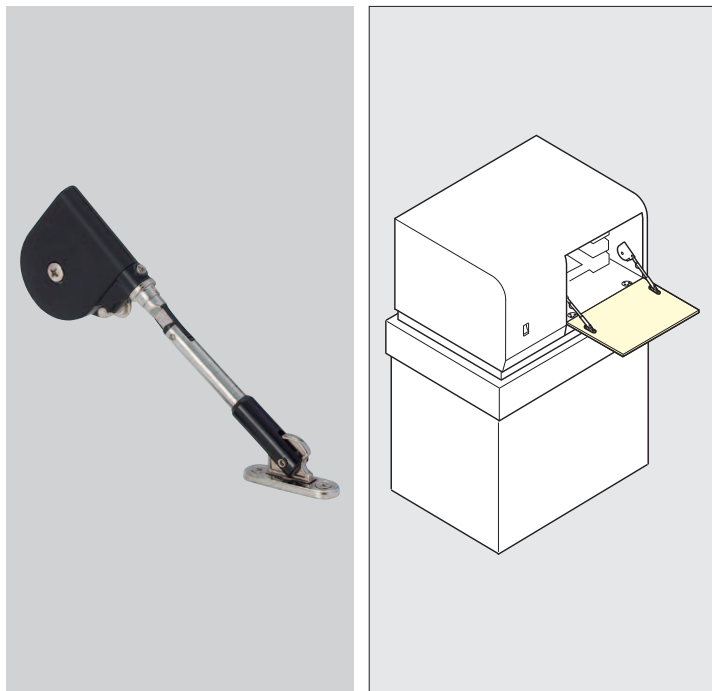

- For DOWNWARD-OPENING FLAP DOOR with concealed, piano, butt or drop hinges.
- Short arm type designed for shorter door height applications.
- SDS-C100TV has a catch to hold the lid in closed position.
- SDS-100TV does not have catch feature. Designed to be used with magnetic catch or touch latch.
- Non-handed: Can be installed on left or right side.
- Torque Calculation:
  - Torque = Door Height x 1/2 x Door Weight.
  - Per Piece : 5~37.6kg·cm.
  - Per Pair : 10~75.2kg·cm.

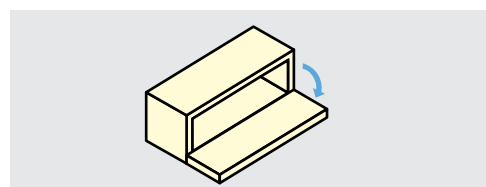

■ Bore Dimensions

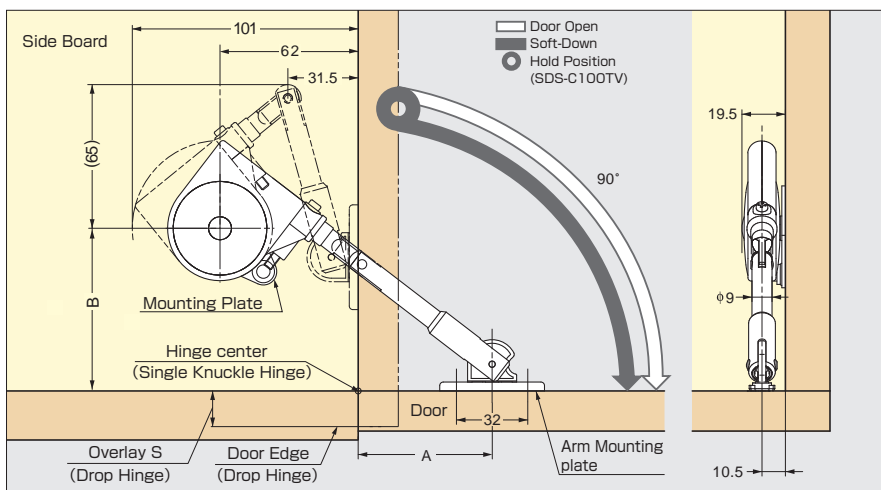

Mounting Plate SDS-A

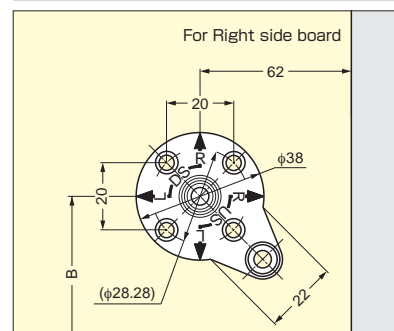

Hinge Type	A	B
Single Knuckle Hinge	60	73
Drop Hinge (SDH-001)	49 + S	62 + S

S: Overlay Coverage in case of drop hinge (14~16mm)

■ Body

Item Code	Item Name	Spec.	Color	Torque Moment		Box	Carton
180-100-258	SDS-100W-TV	Without Catch	White	0.49~1.18N·m	5~12kgf·cm	20pcs	100pcs
180-100-259	SDS-100B-TV	Without Catch	Black	0.49~1.18N·m	5~12kgf·cm	20pcs	100pcs
180-100-006	SDS-C100W-TV	With Catch	White	0.49~1.18N·m	5~12kgf·cm	20pcs	100pcs
180-109-263	SDS-C100B-TV	With Catch	Black	0.49~1.18N·m	5~12kgf·cm	20pcs	100pcs
180-014-181	SDS-100W-TVZ	Without Catch	White	1.62~3.68N·m	16.5~37.6kgf·cm	20pcs	100pcs
180-014-182	SDS-100B-TVZ	Without Catch	Black	1.62~3.68N·m	16.5~37.6kgf·cm	20pcs	100pcs
180-014-183	SDS-C100W-TVZ	With Catch	White	1.62~3.68N·m	16.5~37.6kgf·cm	20pcs	100pcs
180-014-184	SDS-C100B-TVZ	With Catch	Black	1.62~3.68N·m	16.5~37.6kgf·cm	20pcs	100pcs

■ Option SDS · Face Plate · Spacer for Glass

Item Code	Item Name	Material	Finish/Color	Weight	Box	Carton
180-100-260	SDS-50G-CR	Zinc Alloy/ABS	Chrome/Black	25g	50pcs	200pcs
180-928-046	SDS-50G-BL	Zinc Alloy/ABS	Baking Finish/Black	25g	50pcs	200pcs

# SOFT-DOWN STAY



# SDS-C100

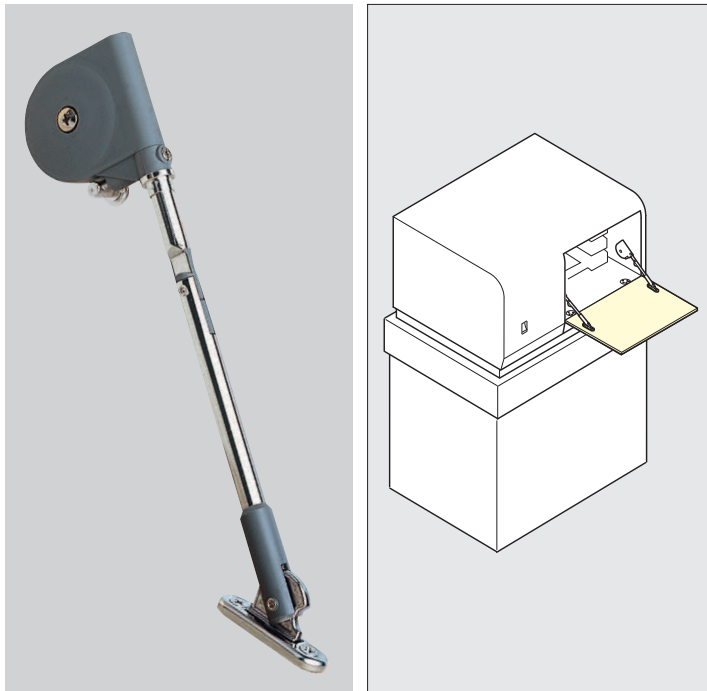

- For DOWNWARD-OPENING FLAP DOOR with concealed, piano, butt or drop hinges.
- SDS-C100 (with catch) is designed to hold door in closed position.
- Non-handed: Can be installed on left or right side.
- Torque Calculation:
  - Torque = Door Height x 1/2 x Door Weight.
  - Per Piece : 35~50 kg-cm.
  - Per Pair : 70~100 kg-cm.
- Short-arm version SDS-100TV (or C100TV) for smaller door height available.

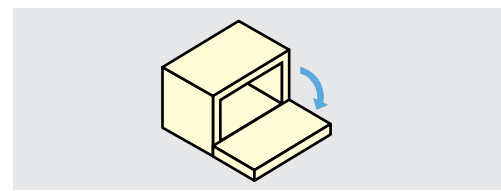
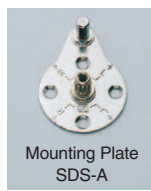
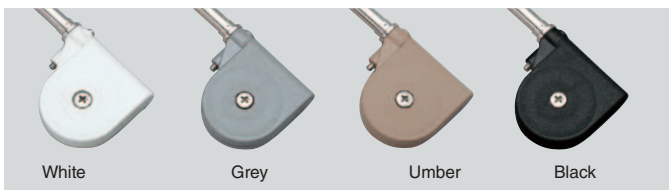

## ■ Bore Dimensions

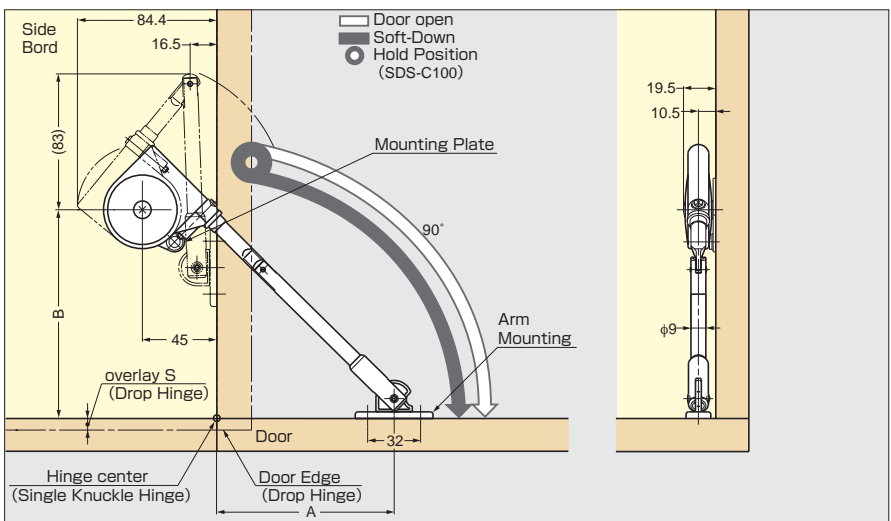

## Mounting Plate SDS-A

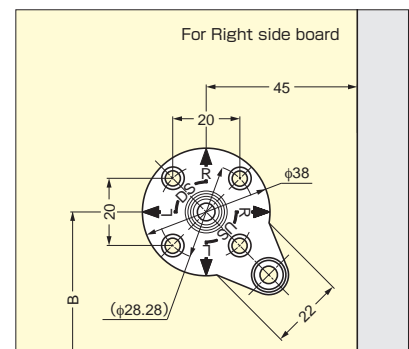

## ■ Body

Item Code	Item Name	Spec.	Material	Finish/Color	Weight	Box	Carton
180-100-261	SDS-100W	Without Catch	ABS/Steel	Nickel/White	167g	20pcs	100pcs
180-100-265	SDS-C100-W	With Catch	ABS/Steel	Nickel/White	167g	20pcs	100pcs
180-100-262	SDS-100G	Without Catch	ABS/Steel	Nickel/Grey	167g	20pcs	100pcs
180-100-266	SDS-C100-G	With Catch	ABS/Steel	Nickel/Grey	167g	20pcs	100pcs
180-100-263	SDS-100U	Without Catch	ABS/Steel	Nickel/Umber	167g	20pcs	100pcs
180-100-267	SDS-C100-U	With Catch	ABS/Steel	Nickel/Umber	167g	20pcs	100pcs
180-100-264	SDS-C100-B	With Catch	ABS/Steel	Nickel/Black	167g	20pcs	100pcs

Hinge Type	Arm Mounting Plate	Mounting Plate
	A	B
Single Knuckle Hinge	100	135
But Hinge (SDH-001)	91+S	126+S

S: Overlay Coverage in case of drop hinge (14~16mm)

## ■ Option SDS · Face Plate · Spacer for Glass

Item Code	Item Name	Material	Finish/Color	Weight	Box	Carton
180-100-260	SDS-50G-CR	Zinc Alloy/ABS	Chrome/Black	25g	50pcs	200pcs
180-928-046	SDS-50G-BL	Zinc Alloy/ABS	Black/Black	25g	50pcs	200pcs

# SOFT-DOWN STAY



# SDS-400-W

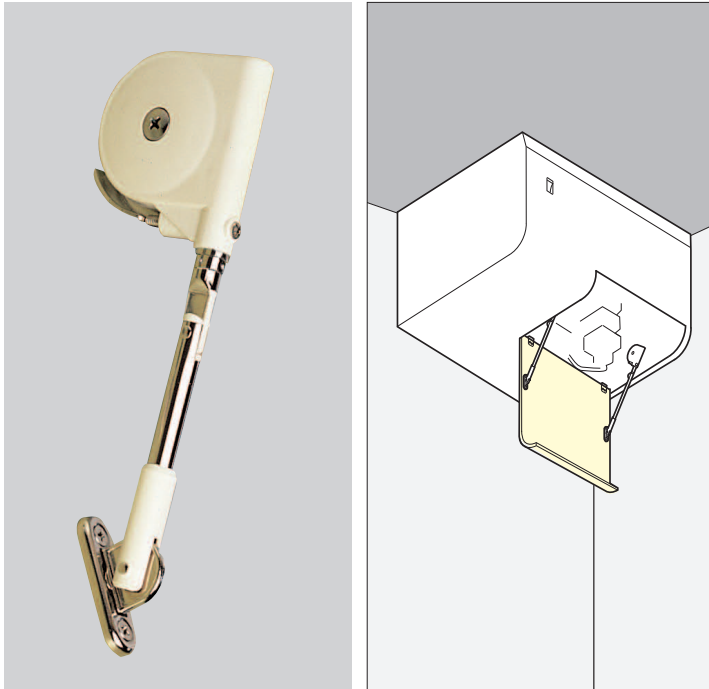

- For DOWNWARD-OPENING FLAP DOOR with concealed, piano, butt or drop hinges. SDS-400 is designed to hold door in closed position.
- Non-handed: Can be installed on left or right side.
- Torque Calculation:
  - Torque = Door Height x 1/2 x Door Weight.
  - Per Piece : 35~50 kg.cm.
  - Per Pair : 70~100 kg.cm.

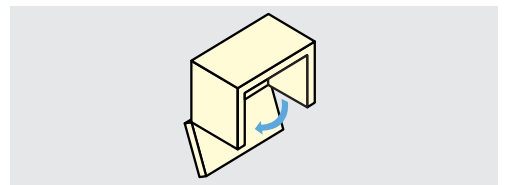

### ■ Bore Dimensions

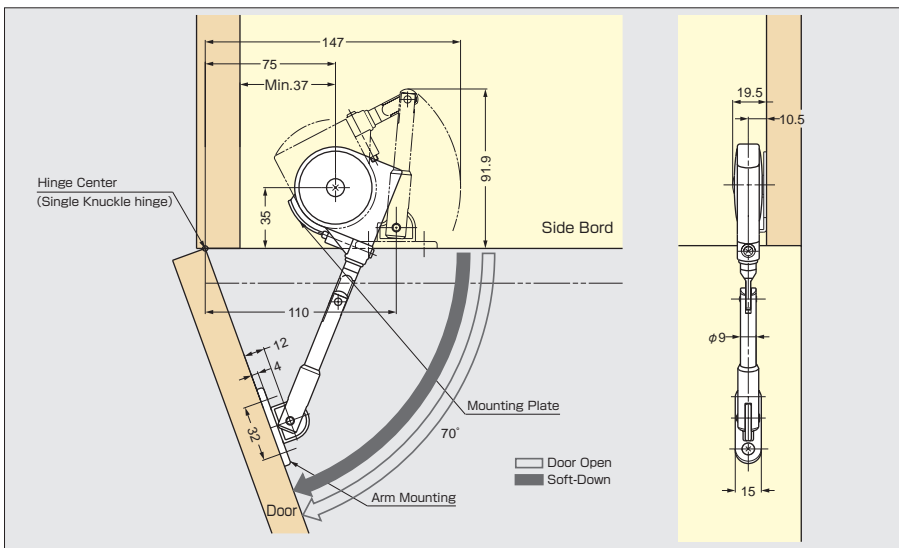

### Mounting Plate SDS-B

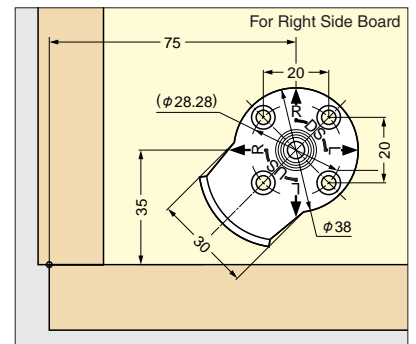

### ■ Body

Item Code	Item Name	Spec.	Material	Finish/Color	Weight	Box	Carton
180-100-286	SDS-400-W	Without Catch	ABS/Steel	Nickel/White	146g	20pcs	100pcs

### ■ Option SDS · Face Plate · Spacer for Glass

Item Code	Item Name	Material	Finish/Color	Weight	Box	Carton
180-100-260	SDS-50G-CR	Zinc Alloy/ABS	Chrome/Black	25g	50pcs	200pcs
180-928-046	SDS-50G-BL	Zinc Alloy/ABS	Black/Black	25g	50pcs	200pcs

# SOFT-DOWN STAY



# SDS-C301N



- For UPWARD-OPENING FLAP DOOR & TOP-OPENING FLAP DOOR with concealed, piano, butt or drop hinges.
- SDS-C301N is designed to hold door in closed and opened position.
- Non-handed: Can be installed on left or right side.
- Torque Calculation:
  - Torque = Door Height x 1/2 x Door Weight.
  - Per Piece : 40~70 kg-cm.
  - Per Pair : 80~140 kg-cm.

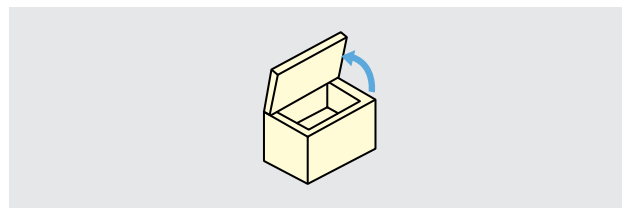
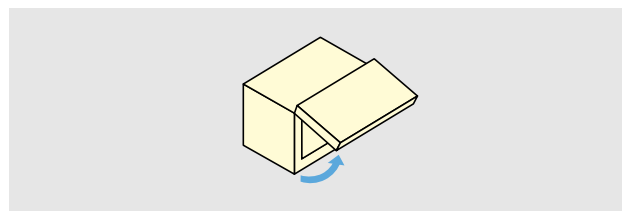
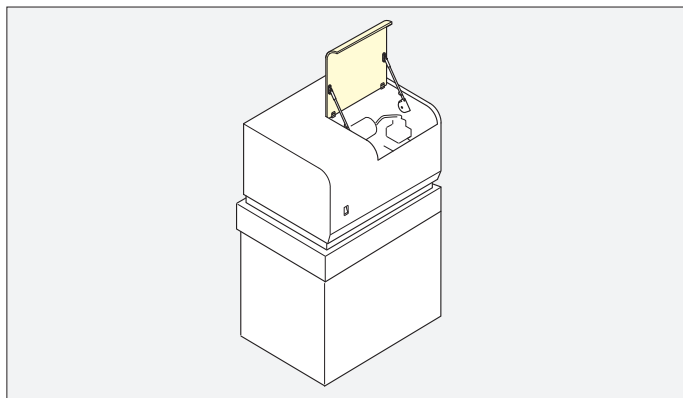
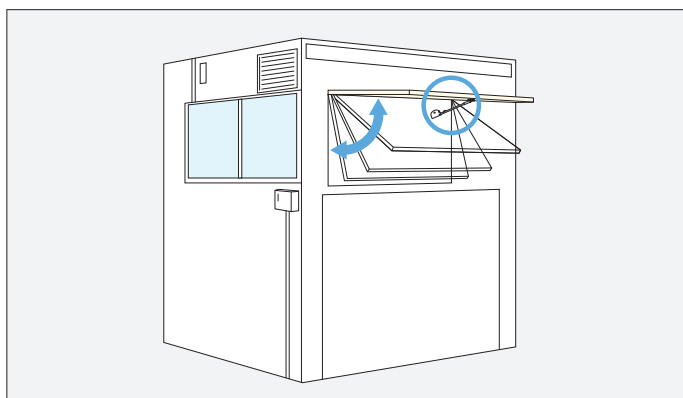

■ Body

Item Code	Item Name	Spec.	Material	Finish/Color	Weight	Box	Carton
180-100-283	SDS-C301N W	With Catch	ABS/Steel	Nickel/White	165g	20pcs	100pcs
180-100-284	SDS-C301N G	With Catch	ABS/Steel	Nickel/Grey	165g	20pcs	100pcs
180-100-285	SDS-C301N BL	With Catch	ABS/Steel	Nickel/Black	165g	20pcs	100pcs

■ Option SDS · Face Plate · Spacer for Glass

Item Code	Item Name	Material	Finish/Color	Weight	Box	Carton
180-100-260	SDS-50G-CR	Zinc Alloy/ABS	Chrome/Black	25g	50pcs	200pcs
180-928-046	SDS-50G-BL	Zinc Alloy/ABS	Black/Black	25g	50pcs	200pcs



■ Bore Dimensions

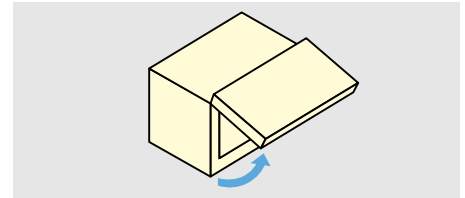
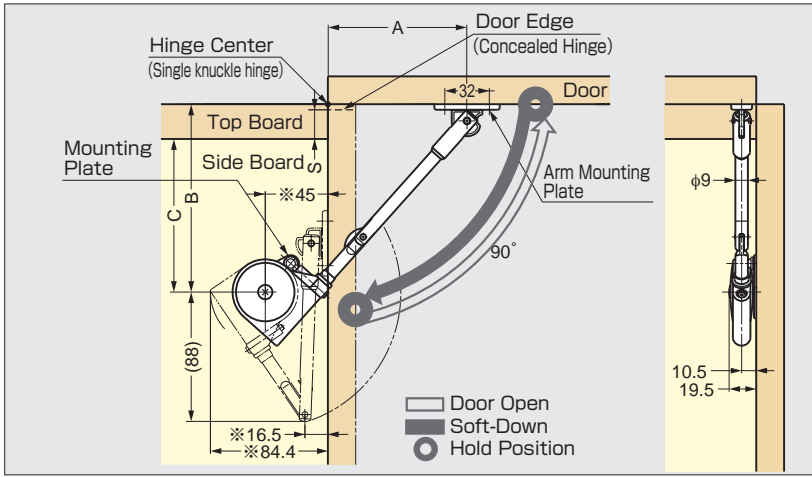

Mounting Plate SDS-A

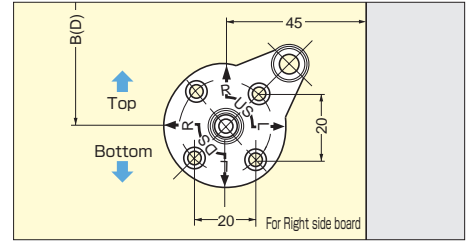

Overlay	Hinge Type	A	B	C
Full Overlay	Single Knuckle Hinge(Butt Hinge)	100	135	-
inset	Single Knuckle Hinge(Butt Hinge)	97	132	-
Full Overlay	Concealed Hinge 230-26/19T	108	-	143-S

■ Bore Dimensions

With Concealed Hinge

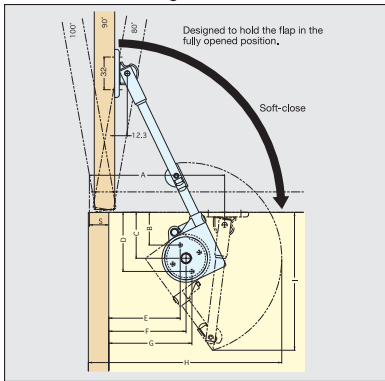

■ Mounting Plate

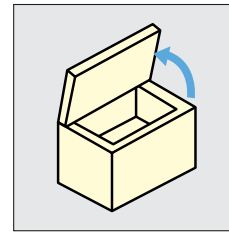
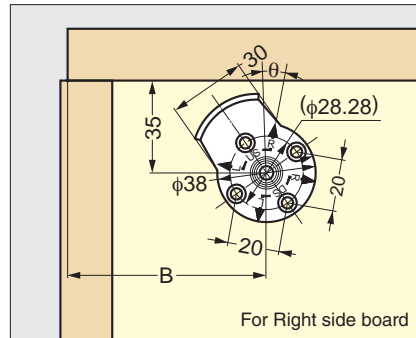

Material	Finish/Color
Steel, Zinc Alloy	Nickel
Plastic	Black, White

With Single Knuckle Hinge

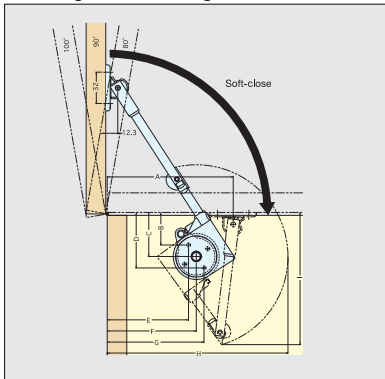

Concealed Hinge

S=Coverage

Opening angle	A	B	C	D	E	F	G	H	I
80°	141	31.9	45	58.1	98.2-S	103.5-S	108.8-S	197.5	134.8
90°	132.5	32.3	45	57.7	88.7-S	95-S	101.3-S	189	134.8
100°	126.5	32.9	45	57.1	81.2-S	88.5-S	95.8-S	182.5	134.8

Single Knuckle Hinge / Overlay Type

Opening angle	A	B	C	D	E	F	G	H	I
80°	138.5	32.6	45	57.4	94.1	101	107.9	195	134.8
90°	128.5	33.2	45	56.8	83.1	91	98.9	185	134.8
100°	121.5	33.9	45	56.1	75.2	84	92.8	178	134.8

Single Knuckle Hinge / Inset Type

Opening angle	A	B	C	D	E	F	G	H	I
80°	129	31.7	45	58.3	86.7	91.5	96.3	185.5	134.8
90°	118.5	32	45	58	75.3	81	86.7	175	134.8
100°	111	32.5	45	57.5	67	73.5	80	167.5	134.8

SDS FACE PLATE

SDS-50G

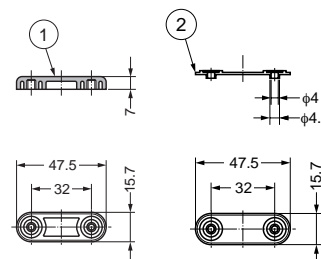

Item Code	Item Name	Material	Weight	Box	Carton
180-100-260	SDS-50G-CR	Zinc Alloy/ABS	25g	50pcs	200pcs
180-928-046	SDS-50G-BL	Zinc Alloy/ABS	25g	50pcs	200pcs

No.	Part Name	Material	Finish	Box
①	Face Plate	Zinc Alloy	Chrome (CR) Black (BL)	1pcs
②	Spacer	ABS	Black	2pcs

# NSD

## ADJUSTABLE SOFT-DOWN STAY

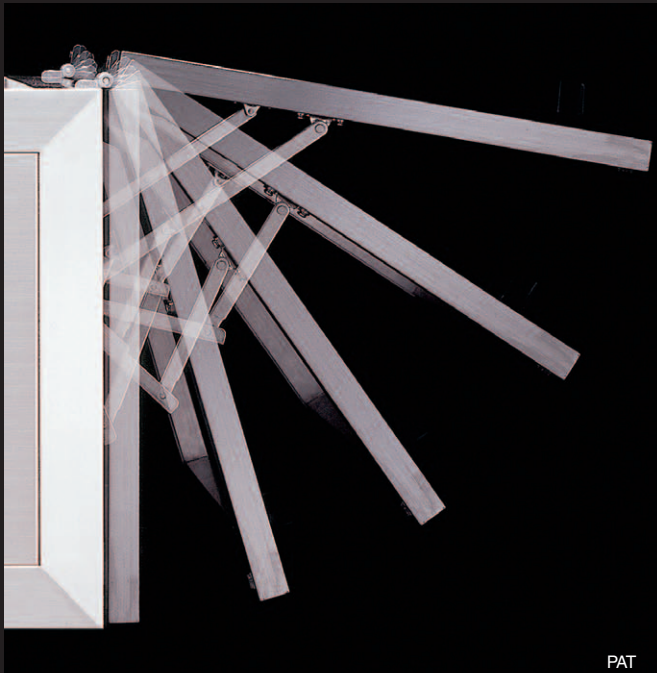

PAT

- Keeps flap/lid from slamming down or flying open.
- Successfully passed for 50,000 open/close private cycle tests.
- Opening/closing speed is adjustable.
- Opening angle is adjustable by changing mounting position.
- Handed.

Designed to operate at room temperature  
0°~40°C (32°~104°F).

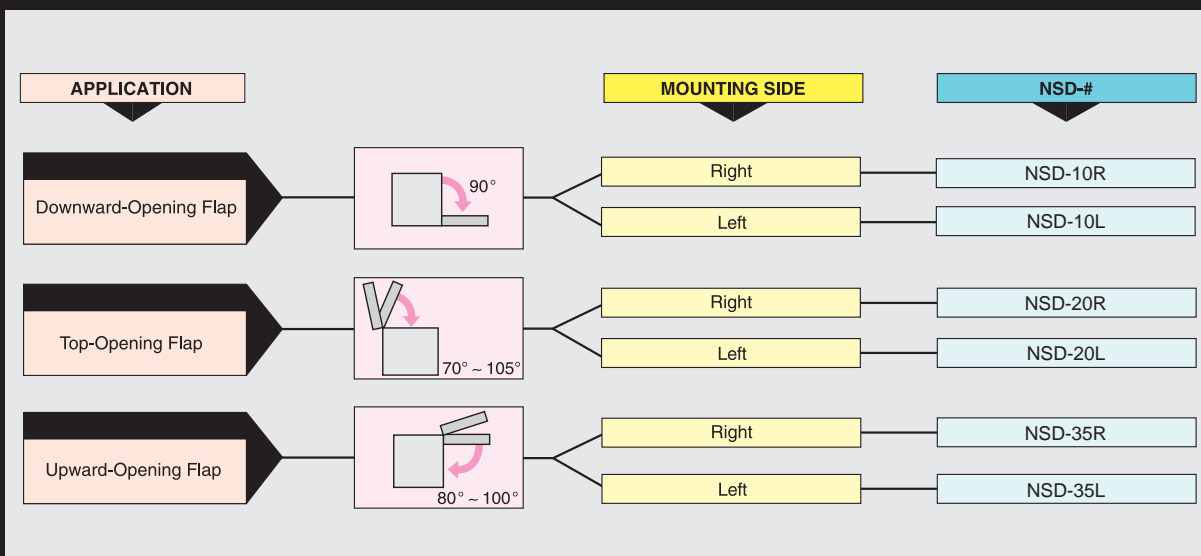
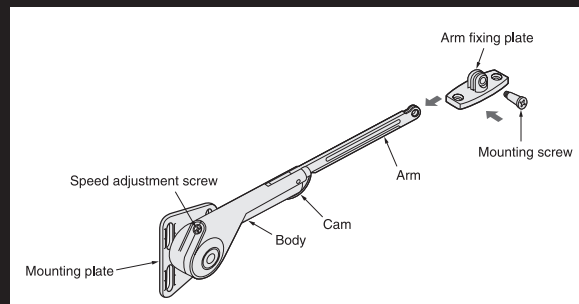

# ADJUSTABLE SOFT-DOWN STAY



## NSD-10



- For DOWNWARD-OPENING FLAP DOOR with piano, butt or drop Hinges.
- NSD-10 is designed to hold door in closed position.
- Torque Calculation :  
Torque = Door Height x 1/2 x Door Weight.  
Per Piece: 20~70 kg·cm.  
Per Pair :40~140 kg·cm.

Material	Finish
Zinc Alloy, Steel	Bright Nickel

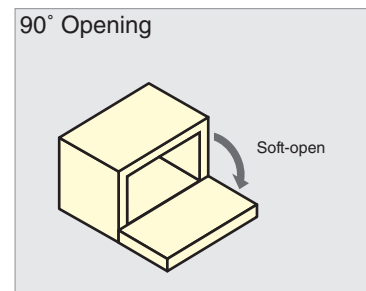
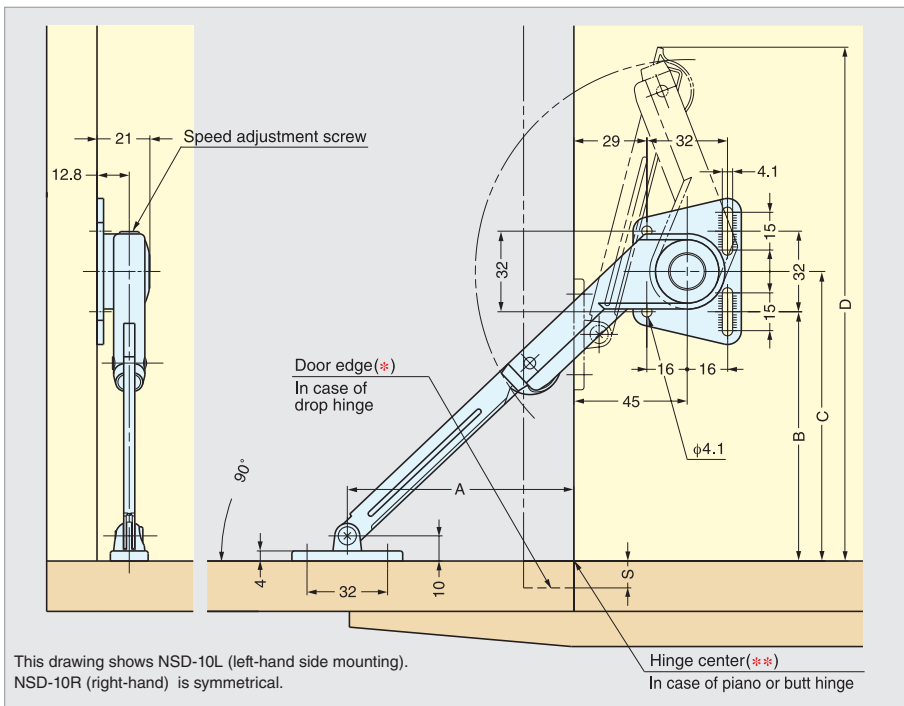
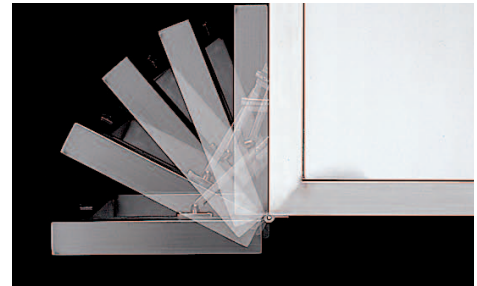

The distance for A, B, C is measured from "door edge (\*)" and "top surface of bottom board" when drop hinges are used, and from "hinge center (\*\*)" and "top surface of bottom board" when piano or butt hinges are used.

Hinge Type	A	B	C	D
Drop Hinge	97	106-S	122-S	211-S
Piano / Butt Hinge	90	99	115	204

Note: "S" dimension is the overlay distance for drop hinge(s).

Item Code	Item Name	Weight	Box	Carton
180-109-376	NSD-10R	210g	20pcs	80pcs
180-109-381	NSD-10L	210g	20pcs	80pcs

# ADJUSTABLE SOFT-DOWN STAY



## NSD-20



- For TOP-OPENING FLAP DOOR with piano, butt or concealed hinges.
- Opening angle adjustable from 70° to 105°
- NSD-20 is designed to hold door in fully opened position.
- Torque Calculation :  
 $\text{Torque} = \text{Door Height} \times 1/2 \times \text{Door Weight}$   
 Per Piece : 20~70 kg-cm.

Material	Finish
Zinc Alloy, Steel	Bright Nickel

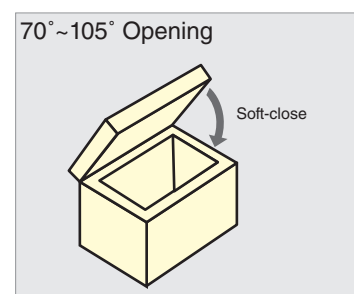
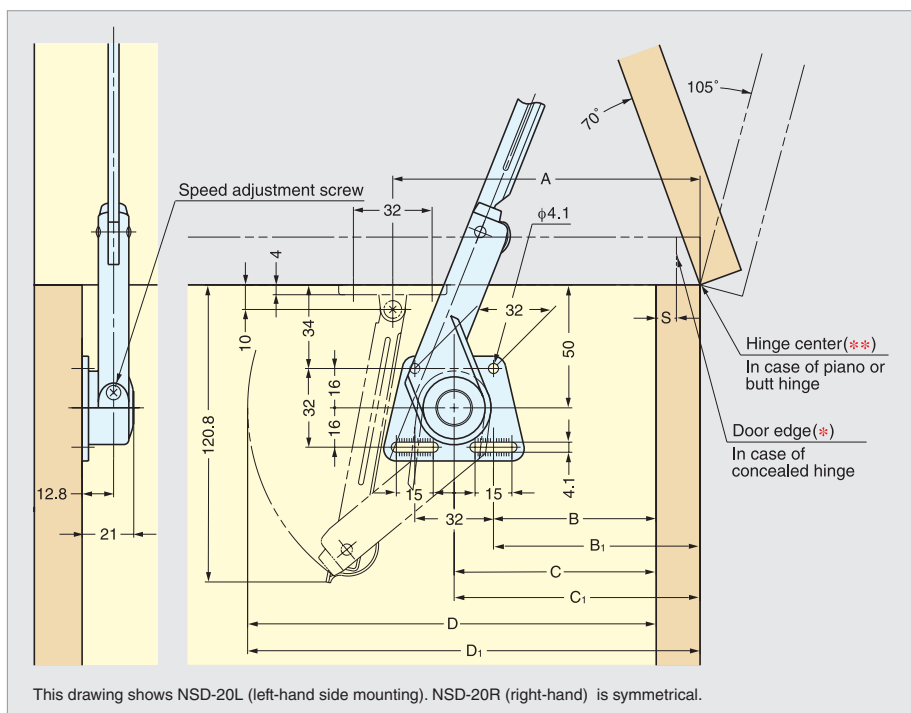
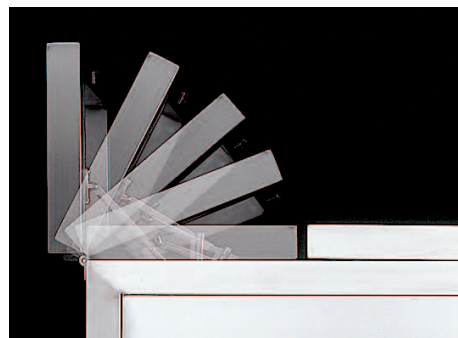

Opening Angle	Hinge Type	A	B	C	D	B <sub>1</sub>	C <sub>1</sub>	D <sub>1</sub>
70°	Concealed Hinge	126	85-S	101-S	185-S	-	-	-
	Piano / Butt Hinge	125	-	-	-	84	100	184
105°	Concealed Hinge	103	62-S	78-S	162-S	-	-	-
	Piano / Butt Hinge	97	-	-	-	56	72	156

Note: "S" dimension is the overlay distance for concealed hinge(s).

Item Code	Item Name	Weight	Box	Carton
180-104-103	NSD-20R	210g	20pcs	80pcs
180-104-102	NSD-20L	210g	20pcs	80pcs

# ADJUSTABLE SOFT-DOWN STAY



## NSD-35

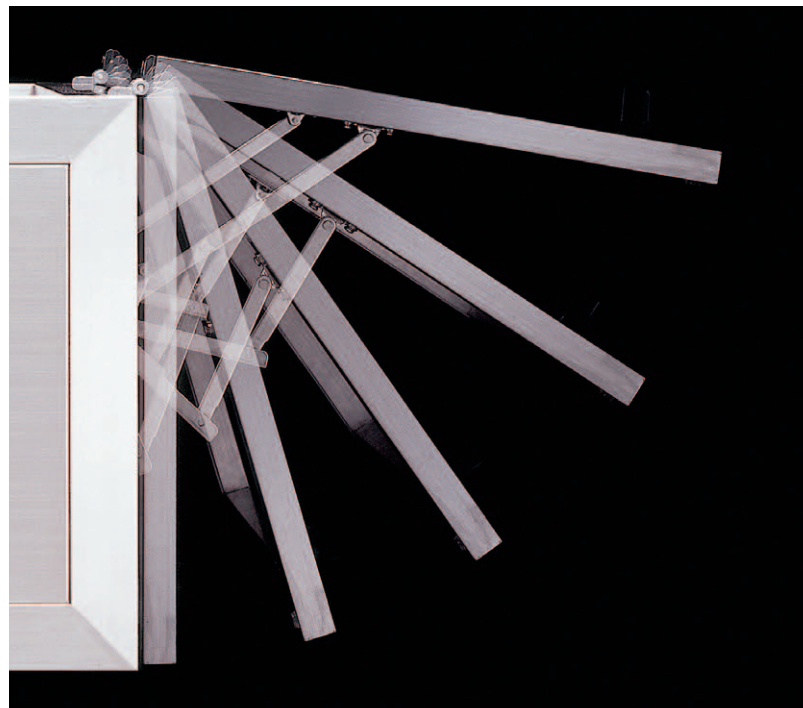

- For UPWARD-OPENING FLAP DOOR with piano, butt or concealed hinges.
- Opening angle adjustable from 80° to 100°.
- NSD-35 is designed to hold door in fully opened position.
- Two stop version (holds door at 65° and 90°) is also available.
- Torque Calculation :  
 Torque = Door Height x 1/2 x Door Weight.  
 Per Piece : 20~70 kg-cm.  
 Per Pair : 40~140 kg-cm.

Material	Finish
Zinc Alloy, Steel	Bright Nickel

### NSDX-AZ Angle Bracket

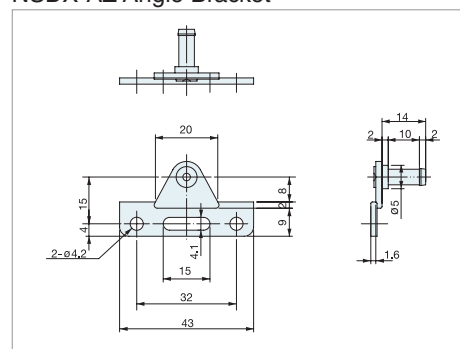

NSDX-AZ (angle bracket) for aluminum frame application available upon request.

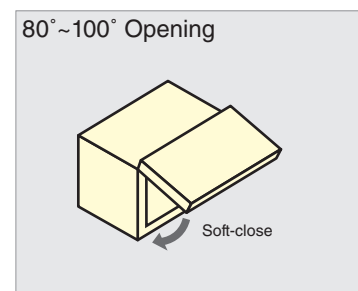
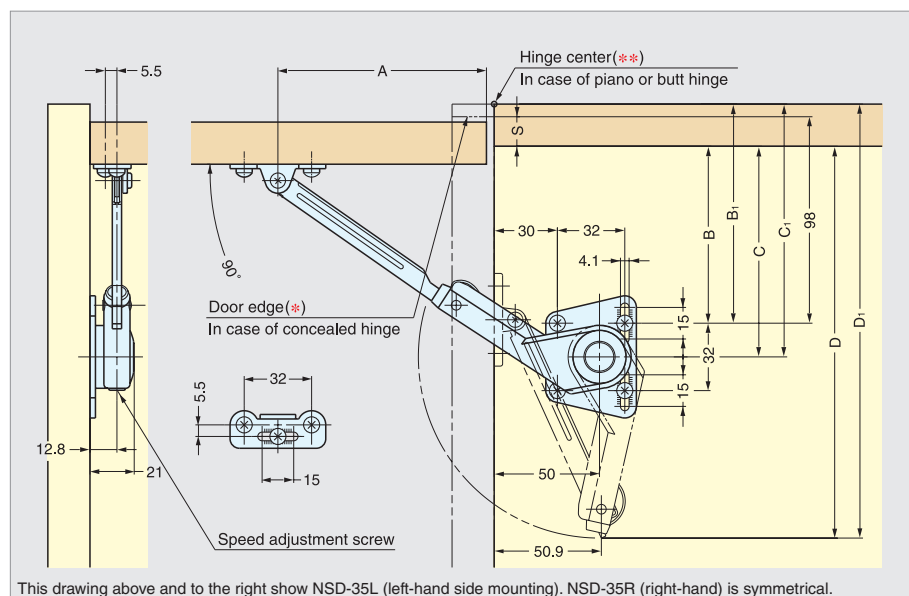

Opening Angle	80°		90°		100°	
	Down		Middle		Up	
Position of Plates	Mounting Plate	Arm Bracket	Mounting Plate	Arm Bracket	Mounting Plate	Arm Bracket
For Hinge Center (Up) ↑ (Down) ↓						

Hinge Type	A	B	C	D	B <sub>1</sub>	C <sub>1</sub>	D <sub>1</sub>	Item Code	Item Name	Weight	Box	Carton
Concealed Hinge	99	98-S	114-S	200-S	-	-	-	108-109-280	NSD-35R	210g	20pcs	80pcs
Piano / Butt Hinge	93	-	-	-	92	108	194	108-109-279	NSD-35L	210g	20pcs	80pcs

ADJUSTABLE SOFT-DOWN STAY (SHORT-ARM)



NSDX-10(R/L)K/TV



- For DOWNWARD-OPENING FLAP DOOR with concealed, piano, butt or drop hinges.
- Short arm type designed for shorter door height applications.
- Handed: Specific left and right hand mounting.
- Torque Calculation:
  - Torque = Door Height × 1/2 × Door Weight.
  - Per Piece: 10 ~ 20kgf-cm.
  - Per Pair: 20 ~ 40kgf-cm.

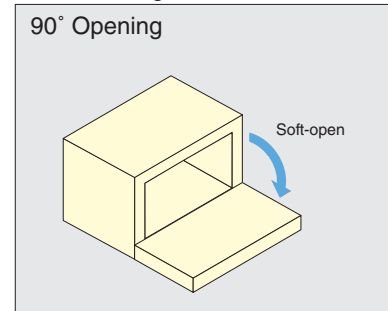

Application

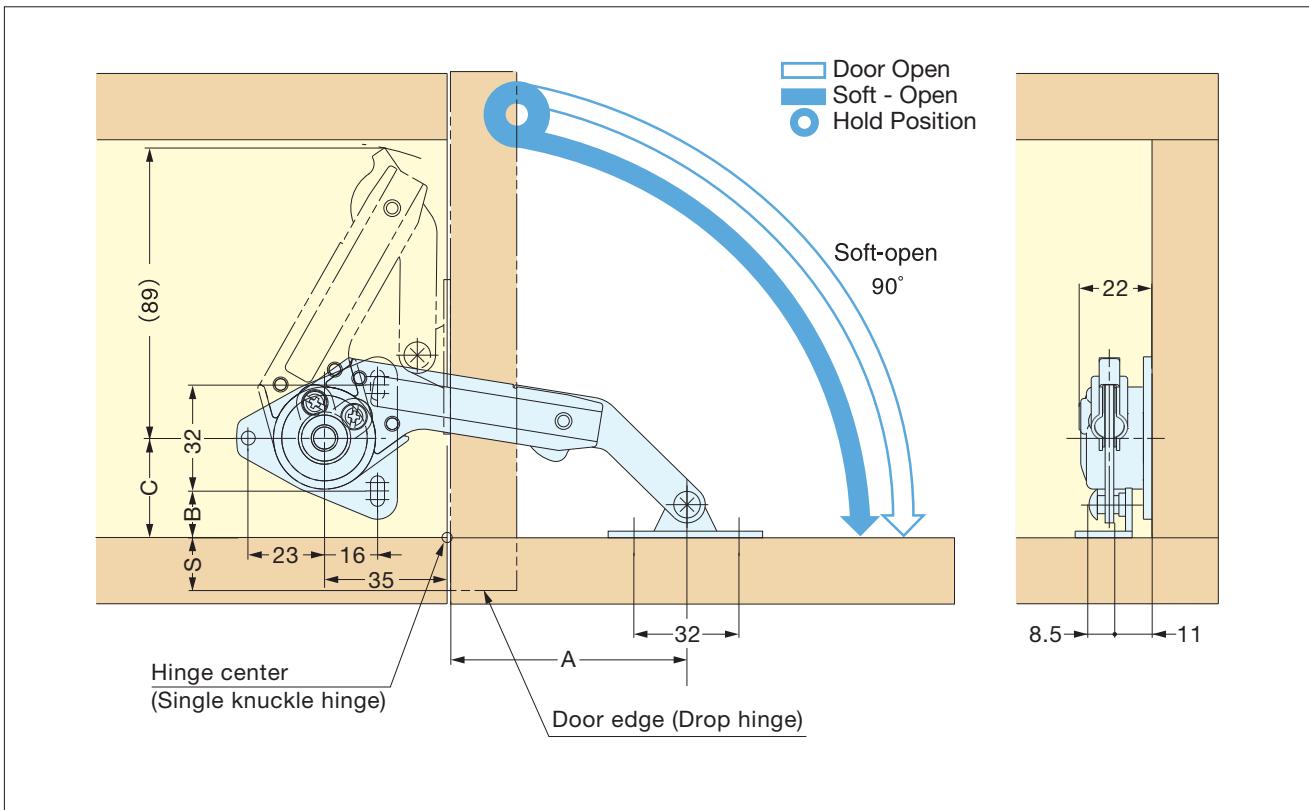

Hinge Type	A	B	C
Single Knuckle Hinge	58+S	14	30
Drop Hinge	71	27	43

Item Code	Item Name	Material	Finish	Weight	Box	Carton
180-016425	NSDX-10RK / TV Right	Zinc Alloy/Steel	Nickel	143g	20pcs	80pcs
180-016424	NSDX-10LK / TV Left					

# SOFT-DOWN STAY SOLUTIONS FOR ALUMINUM FRAME



## Installation

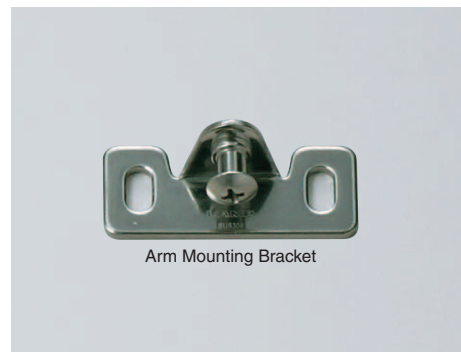
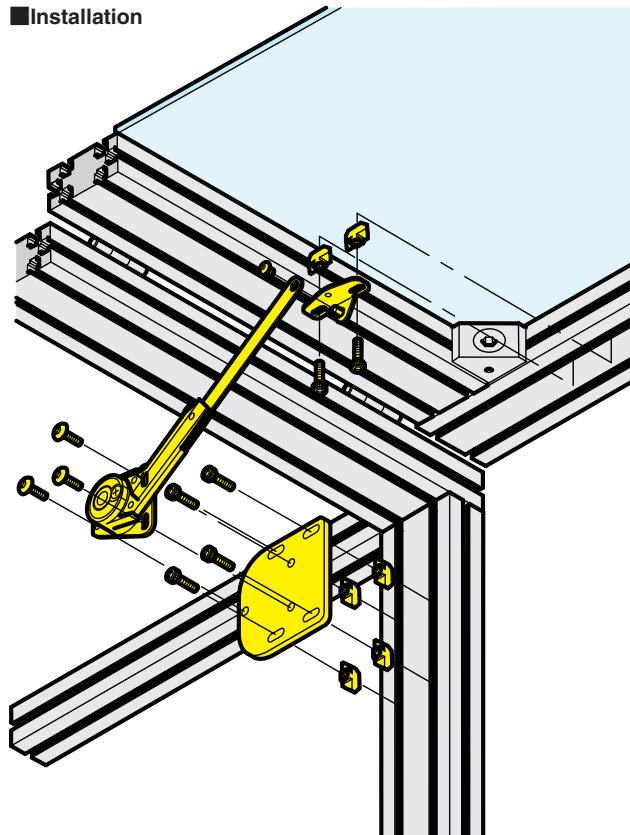

# HDS/HDSN



## HEAVY DUTY SOFT-DOWN STAY

- One-way rotary damper offers smooth and soft downward movement preventing lids or doors from slamming shut.
- Adjustable opening angle.
- Easy installation.
- Successfully passed for 30,000 open / close private cycle tests.

Designed to operate at room temperature  
0°~40°C (32°~104°F).

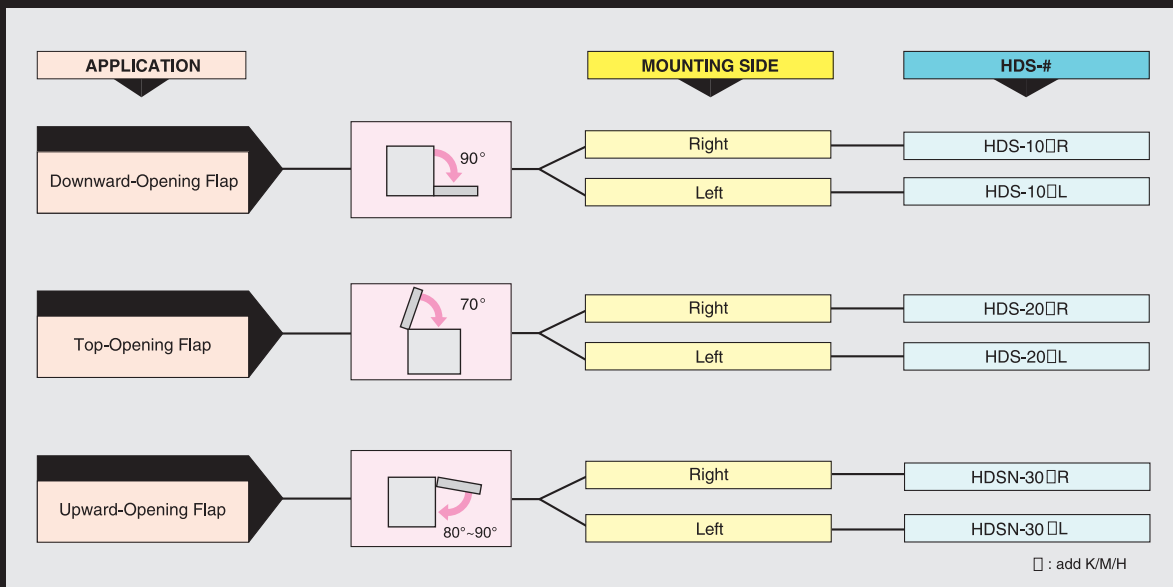

### ■ HDS

Door Height	HDS-10K HDS-20K HDS-30K	HDS-10M HDS-20M HDS-30M	HDS-10H HDS-20H HDS-30H
	Door Weight/piece	Door Weight/piece	Door Weight/piece
300	9.34~ 13.33 kg	13.34~ 16.66 kg	16.67~ 20.00 kg
350	8.00~ 11.42 kg	11.43~ 14.28 kg	14.29~ 17.14 kg
400	7.00~ 9.99 kg	10.00~ 12.49 kg	12.50~ 15.00 kg
450	6.23~ 8.88 kg	8.89~ 11.11 kg	11.12~ 13.33 kg
500	5.60~ 7.99 kg	8.00~ 9.99 kg	10.00~ 12.00 kg
550	5.1 ~ 7.27 kg	7.28~ 9.09 kg	9.10~ 10.90 kg
600	4.67~ 6.66 kg	6.67~ 8.33 kg	8.34~ 10.00 kg

For the right type selection, refer to the graph and the illustration.



# HEAVY DUTY SOFT-DOWN STAY



# HDS-10



- For DOWNWARD-OPENING FLAP DOOR with concealed, piano, butt or drop hinges.
- HDS-10 is designed to hold door in closed and opened position.
- Used in pairs.
- Handed: Specific left and right hand mounting.

### Torque Calculation

Torque Moment/2pcs	Model	piece
13.7~ 19.5 N·m	K	2pcs
19.6~ 24.4 N·m	M	2pcs
24.5~ 29.4 N·m	H	2pcs

$$\frac{\text{Door Height (m)}}{2} \times \text{Door Weight (kg)} \times 9.8 = \text{Torque Moment (N·m)}$$

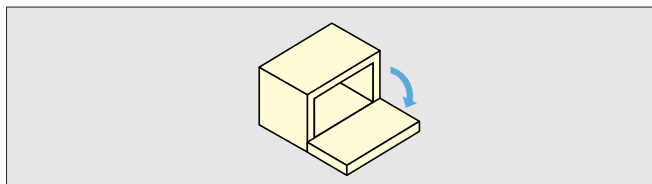

### Installation

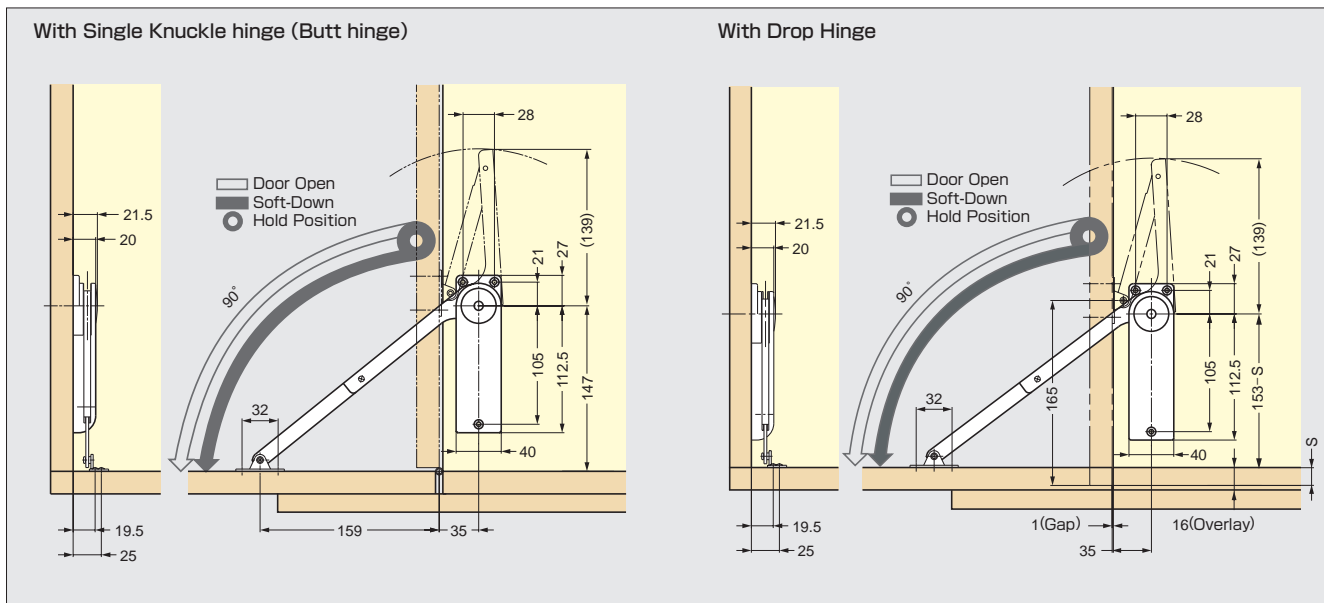

### Body

Item Code	Item Name	Spec.	Material	Finish/Color	Model	Torque Mornment/2pcs		Weight	Box
						Opening Angle80°	Opening Angle80°		
180-104-066	HDS-10KR-BL	Right	ABS/Steel	Nickel/Black	K	13.7~19.5 N·m	140~199kgf·cm	292g	40pcs
180-104-067	HDS-10KL-BL	Left	ABS/Steel	Nickel/Black	K	13.7~19.5 N·m	140~199kgf·cm	292g	40pcs
180-104-072	HDS-10KR-WT	Right	ABS/Steel	Nickel/White	K	13.7~19.5 N·m	140~199kgf·cm	292g	40pcs
180-104-073	HDS-10KL-WT	Left	ABS/Steel	Nickel/White	K	13.7~19.5 N·m	140~199kgf·cm	292g	40pcs
180-104-068	HDS-10MR-BL	Right	ABS/Steel	Nickel/Black	M	19.6~24.4 N·m	200~249kgf·cm	302g	40pcs
180-104-069	HDS-10ML-BL	Left	ABS/Steel	Nickel/Black	M	19.6~24.4 N·m	200~249kgf·cm	302g	40pcs
180-104-074	HDS-10MR-WT	Right	ABS/Steel	Nickel/White	M	19.6~24.4 N·m	200~249kgf·cm	302g	40pcs
180-104-075	HDS-10ML-WT	Left	ABS/Steel	Nickel/White	M	19.6~24.4 N·m	200~249kgf·cm	302g	40pcs
180-104-070	HDS-10HR-BL	Right	ABS/Steel	Nickel/Black	H	24.5~29.3 N·m	250~300kgf·cm	309g	40pcs
180-104-071	HDS-10HL-BL	Left	ABS/Steel	Nickel/Black	H	24.5~29.3 N·m	250~300kgf·cm	309g	40pcs
180-104-076	HDS-10HR-WT	Right	ABS/Steel	Nickel/White	H	24.5~29.3 N·m	250~300kgf·cm	309g	40pcs
180-104-077	HDS-10HL-WT	Left	ABS/Steel	Nickel/White	H	24.5~29.3 N·m	250~300kgf·cm	309g	40pcs

# HEAVY DUTY SOFT-DOWN STAY



# HDS-20



- For TOP-OPENING FLAP DOOR with concealed, piano, butt or concealed hinges.
- Used in pairs.
- HDS-20 is designed to hold door in fully opened position.
- Handed: Specific left and right hand mounting.

### ■ Torque Calculation

Torque Moment/2pcs	Model	piece
13.7~ 19.5 N·m	K	2pcs
19.6~ 24.4 N·m	M	2pcs
24.5~ 29.4 N·m	H	2pcs

$$\frac{\text{Door Height (m)}}{2} \times \text{Door Weight (kg)} \times 9.8 = \text{Torque Moment (N} \cdot \text{m)}$$

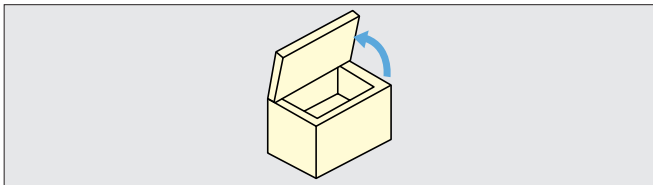

### ■ Installation

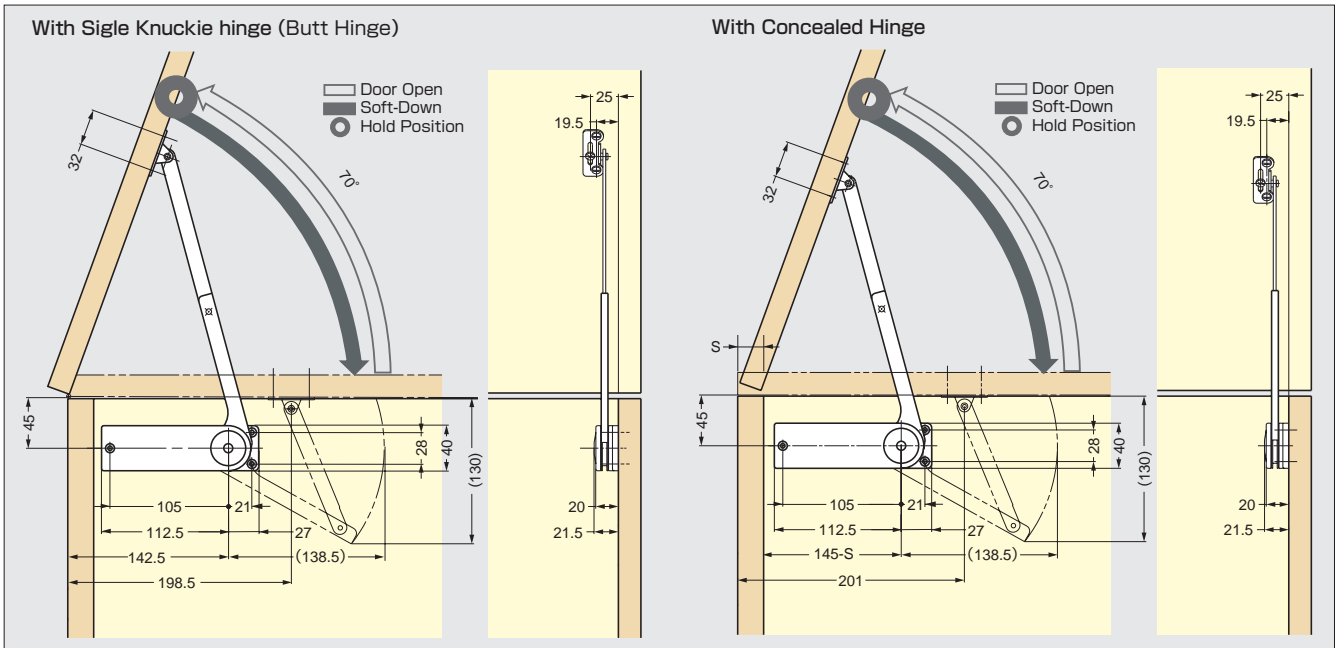

### ■ Body

Item Code	Item Name	Spec.	Material	Finish/Color	Model	Torque Moment/2pcs		Weight	Box
						Opening Angle80°	Opening Angle80°		
180-109-236	HDS-20KR-BL	Right	ABS/Steel	Nickel/Black	K	13.7~19.5 N·m	140~199kgf·cm	282g	40pcs
180-109-237	HDS-20KL-BL	Left	ABS/Steel	Nickel/Black	K	13.7~19.5 N·m	140~199kgf·cm	282g	40pcs
180-109-242	HDS-20KR-WT	Right	ABS/Steel	Nickel/White	K	13.7~19.5 N·m	140~199kgf·cm	282g	40pcs
180-109-243	HDS-20KL-WT	Left	ABS/Steel	Nickel/White	K	13.7~19.5 N·m	140~199kgf·cm	282g	40pcs
180-109-238	HDS-20MR-BL	Right	ABS/Steel	Nickel/Black	M	19.6~24.4 N·m	200~249kgf·cm	289g	40pcs
180-109-239	HDS-20ML-BL	Left	ABS/Steel	Nickel/Black	M	19.6~24.4 N·m	200~249kgf·cm	289g	40pcs
180-109-244	HDS-20MR-WT	Right	ABS/Steel	Nickel/White	M	19.6~24.4 N·m	200~249kgf·cm	289g	40pcs
180-109-245	HDS-20ML-WT	Left	ABS/Steel	Nickel/White	M	19.6~24.4 N·m	200~249kgf·cm	289g	40pcs
180-109-240	HDS-20HR-BL	Right	ABS/Steel	Nickel/Black	H	24.5~29.3 N·m	250~300kgf·cm	297g	40pcs
180-109-241	HDS-20HL-BL	Left	ABS/Steel	Nickel/Black	H	24.5~29.3 N·m	250~300kgf·cm	297g	40pcs
180-109-246	HDS-20HR-WT	Right	ABS/Steel	Nickel/White	H	24.5~29.3 N·m	250~300kgf·cm	297g	40pcs
180-109-247	HDS-20HL-WT	Left	ABS/Steel	Nickel/White	H	24.5~29.3 N·m	250~300kgf·cm	297g	40pcs

# HEAVY DUTY SOFT-DOWN STAY



## HDS-30



- For TOP-OPENING FLAP DOOR with concealed, hinges.
- Used in pairs.
- HDSN-30 is designed to hold door in Closed and opened position.
- Handed: Specific left and right hand mounting.

### Torque Calculation

Torque Moment/2pcs	Model	piece
13.7~ 19.5 N·m	K	2pcs
19.6~ 24.4 N·m	M	2pcs
24.5~ 29.4 N·m	H	2pcs

$$\frac{\text{Door Height (m)}}{2} \times \text{Door Weight (kg)} \times 9.8 = \text{Torque Moment (N} \cdot \text{m)}$$

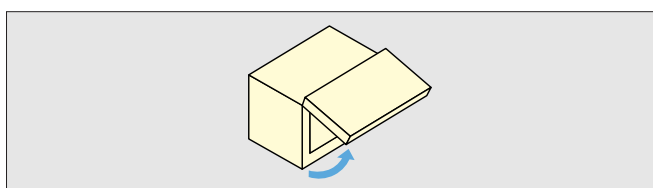

### Installation

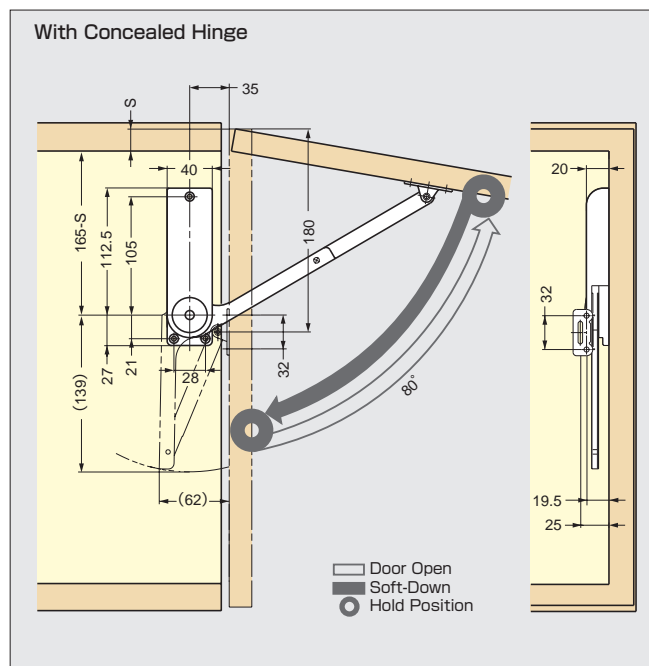
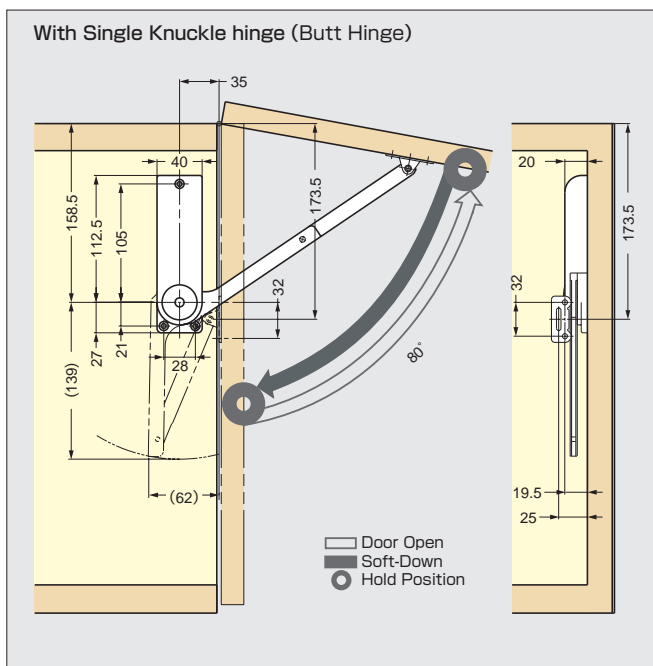

### Body

Item Code	Item Name	Spec.	Material	Finish/Color	Model	Torque Morment/2pcs		Weight	Box
						Opening Angle80°	Opening Angle80°		
180-104-078	HDS-30KR-BL	Right	ABS/Steel	Nickel/Black	K	13.7~19.5 N·m	140~199kgf·cm	275g	40pcs
180-104-079	HDS-30KL-BL	Left	ABS/Steel	Nickel/Black	K	13.7~19.5 N·m	140~199kgf·cm	275g	40pcs
180-109-270	HDS-30KR-WT	Right	ABS/Steel	Nickel/White	K	13.7~19.5 N·m	140~199kgf·cm	275g	40pcs
180-109-271	HDS-30KL-WT	Left	ABS/Steel	Nickel/White	K	13.7~19.5 N·m	140~199kgf·cm	275g	40pcs
180-104-080	HDS-30MR-BL	Right	ABS/Steel	Nickel/Black	M	19.6~24.4 N·m	200~249kgf·cm	293g	40pcs
180-104-081	HDS-30ML-BL	Left	ABS/Steel	Nickel/Black	M	19.6~24.4 N·m	200~249kgf·cm	293g	40pcs
180-109-272	HDS-30MR-WT	Right	ABS/Steel	Nickel/White	M	19.6~24.4 N·m	200~249kgf·cm	293g	40pcs
180-109-273	HDS-30ML-WT	Left	ABS/Steel	Nickel/White	M	19.6~24.4 N·m	200~249kgf·cm	293g	40pcs
180-104-082	HDS-30HR-BL	Right	ABS/Steel	Nickel/Black	H	24.5~29.3 N·m	250~300kgf·cm	298g	40pcs
180-104-083	HDS-30HL-BL	Left	ABS/Steel	Nickel/Black	H	24.5~29.3 N·m	250~300kgf·cm	298g	40pcs
180-109-274	HDS-30HR-WT	Right	ABS/Steel	Nickel/White	H	24.5~29.3 N·m	250~300kgf·cm	298g	40pcs
180-109-275	HDS-30HL-WT	Left	ABS/Steel	Nickel/White	H	24.5~29.3 N·m	250~300kgf·cm	298g	40pcs

# HEAVY DUTY SOFT-DOWN STAY



## HDSN-30



- For UPWARD-OPENING FLAP DOOR with concealed hinges.
- Used in pairs.
- HDSN-30 is designed to hold door in closed and opened position.
- Handed: Specific left and right hand mounting.

### Torque Calculation

Torque Moment (2pcs)		Model	Piece
Opening Angle90°	Opening Angle80°		
13.7~ 17.5 N·m	13.7~ 19.5 N·m	K	2pcs
17.6~ 21.5 N·m	19.6~ 24.4 N·m	M	2pcs
21.6~ 25.4 N·m	24.5~ 29.3 N·m	H	2pcs
25.5~ 29.4 N·m	29.4~ 34.3 N·m	S	2pcs

$$\frac{\text{Door Height (m)}}{2} \times \text{Door Weight (kg)} \times 9.8 = \text{Torque Moment (N} \cdot \text{m)}$$

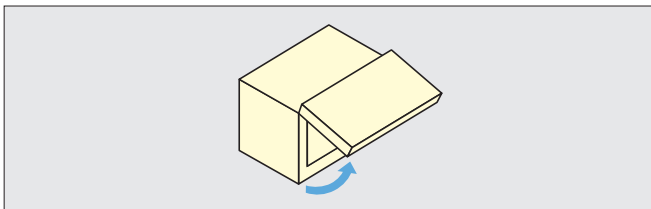

### Installation

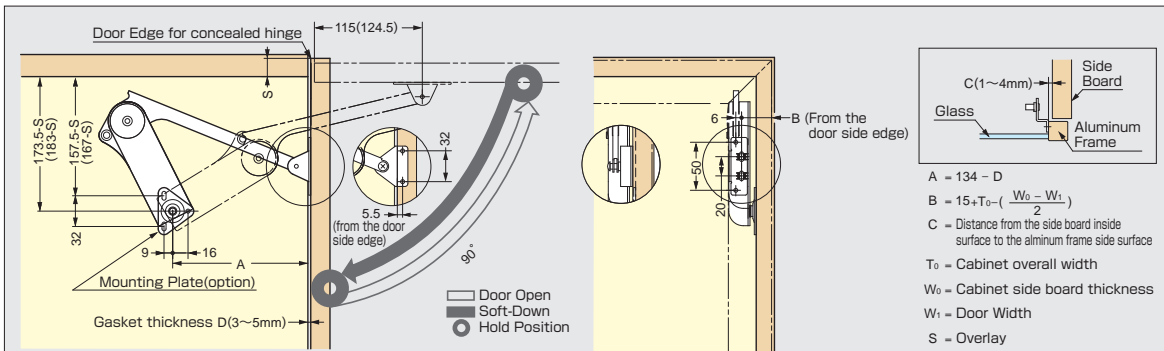

### Body

Item Code	Item Name	Spec.	Material	Finish/Color	Model	Torque Moment/2pcs				Weight	Box
						Opening Angle90°	Opening Angle80°	Opening Angle90°	Opening Angle80°		
180-109-602	HDSN-30KR	Right	ABS/Steel	Nickel/Light Grey	K	13.7~ 17.5 N·m	13.7~ 19.5 N·m	140~ 179kgf·cm	140~ 199kgf·cm	415g	40pcs
180-109-601	HDSN-30KL	Left	ABS/Steel	Nickel/Light Grey	K	13.7~ 17.5 N·m	13.7~ 19.5 N·m	140~ 179kgf·cm	140~ 199kgf·cm	415g	40pcs
180-109-604	HDSN-30MR	Right	ABS/Steel	Nickel/Light Grey	M	17.6~ 21.5 N·m	19.6~ 24.4 N·m	180~ 219kgf·cm	200~ 249kgf·cm	415g	40pcs
180-109-603	HDSN-30ML	Left	ABS/Steel	Nickel/Light Grey	M	17.6~ 21.5 N·m	19.6~ 24.4 N·m	180~ 219kgf·cm	200~ 249kgf·cm	415g	40pcs
180-109-606	HDSN-30HR	Right	ABS/Steel	Nickel/Light Grey	H	21.6~ 25.4 N·m	24.5~ 29.3 N·m	220~ 259kgf·cm	250~ 299kgf·cm	415g	40pcs
180-109-605	HDSN-30HL	Left	ABS/Steel	Nickel/Light Grey	H	21.6~ 25.4 N·m	24.5~ 29.3 N·m	220~ 259kgf·cm	250~ 299kgf·cm	415g	40pcs
180-109-608	HDSN-30SR	Right	ABS/Steel	Nickel/Light Grey	S	25.5~ 34.3 N·m	29.4~ 34.3 N·m	260~ 300kgf·cm	300~ 350kgf·cm	415g	40pcs
180-109-607	HDSN-30SL	Left	ABS/Steel	Nickel/Light Grey	S	25.5~ 34.3 N·m	29.4~ 34.3 N·m	260~ 300kgf·cm	300~ 350kgf·cm	415g	40pcs

### Arm Mounting Plate (Sold separately)

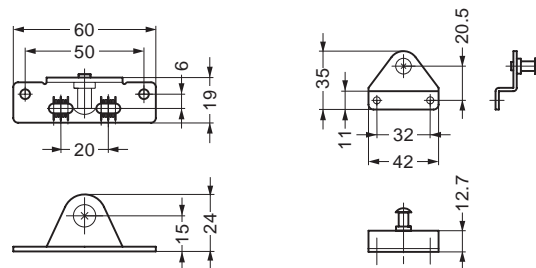

Item Code	Item Name	Spec.	Material	Finish	Weight	Box
180-109-609	HDSN-SZ	45mm width aluminum frame door or wood door	Steel	Nickel	24g	120pcs
180-109-610	HDSN-AZ	20mm width aluminum frame door	Steel	Nickel	25g	120pcs

# Aluminum Profile Applications.

■ HDS-10

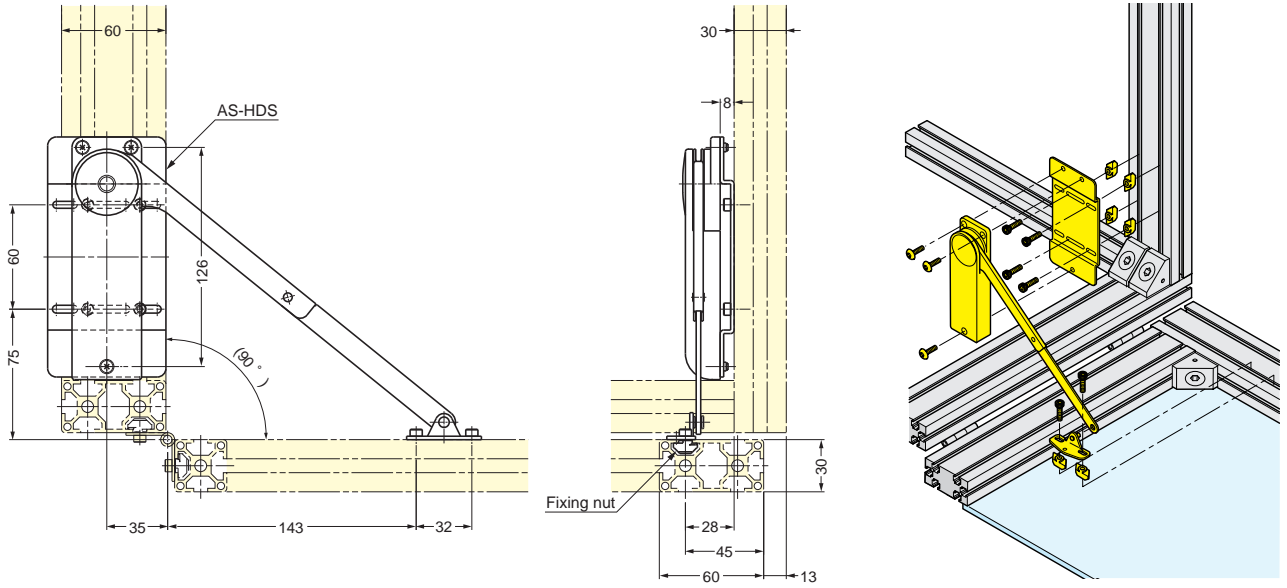

■ HDS-20

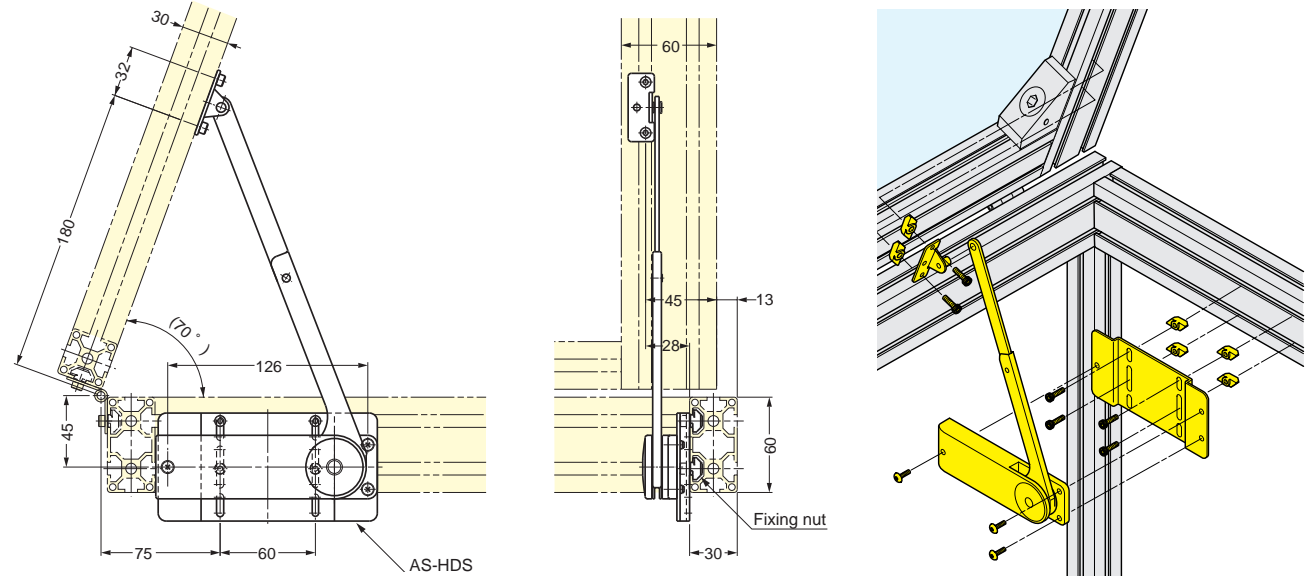

■ HDS-30

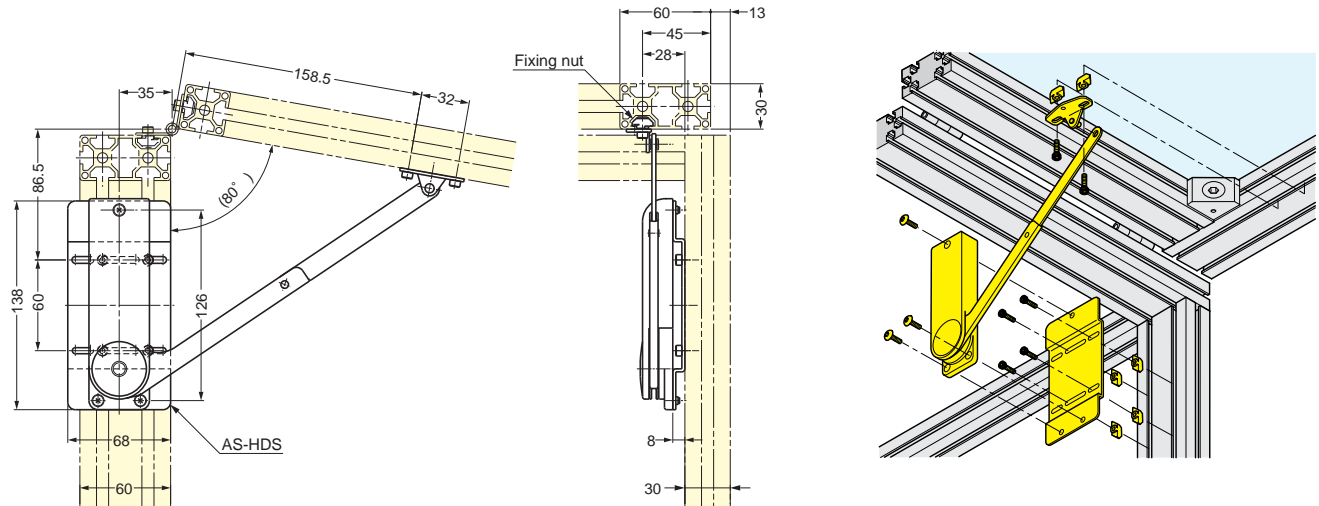

# SLUN

## VERTICAL SWING LIFT-UP MECHANISM

- Unique swing mechanism provides a lift-assist feature to help lift doors and hold at the opened position.
- Sleek, compact design provides maximum access.
- Easy installation.
- Successfully passed for 30,000 open / close private cycle tests.

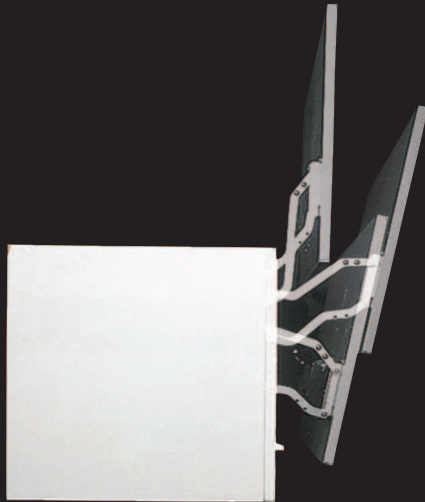

Designed to operate at room temperature  
0°~40°C (32°~104°F).



**VERTICAL SWING LIFT-UP MECHANISM**   **SLUN**



- Unique mechanism will help lift doors and hold at the open position.
- Sleek & compact design.
- Easy installation.
- Adjustable arm mounting plate.
- Patented LAPCON technology provides a smooth and quiet motion.
- Successfully passed 30,000 open/close private cycle tests.
- Recommended Door Size and Weight:
  - Width, 600~900 mm (23-5/8" ~35-7/16")
  - Height, 390~450 mm (15-23/64" ~17-23/32") / door.
  - Weight, 2.5~5.2 kg (5.5~11.4 lbs) / door.
  - SLUH (short arm version) available for shorter doors.

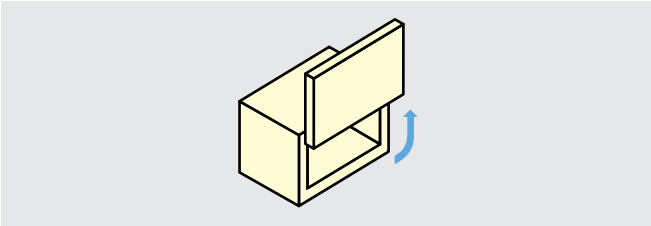

■ Installation

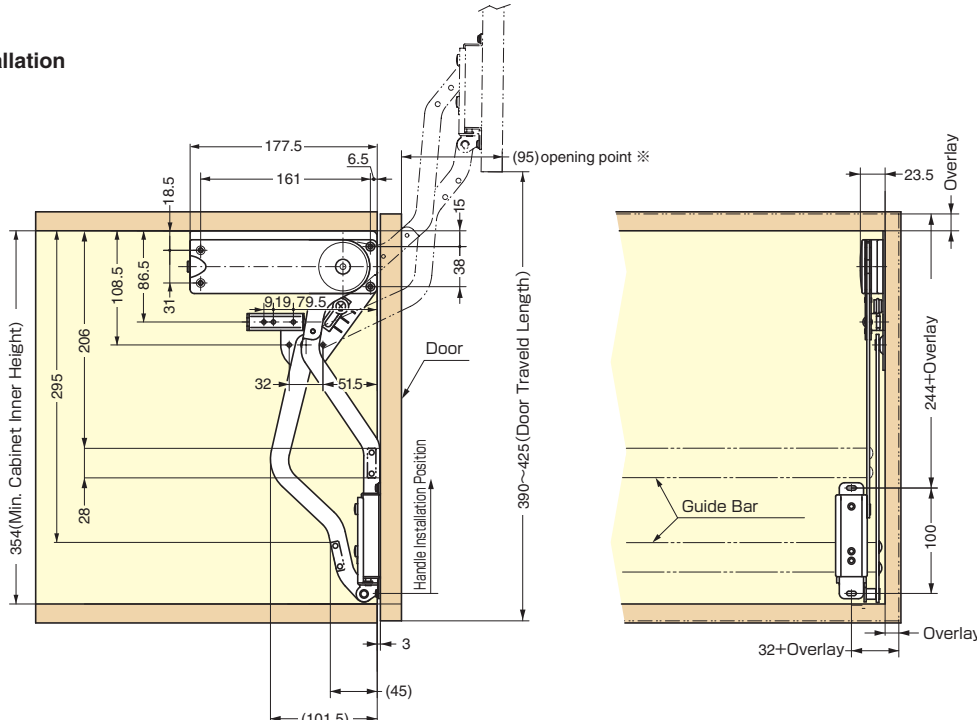

※267mm at max opening point

Item Code	Item Name	Material	Finish/Color	Door Width	Door Height	Door Weight	Travel Length	Box
180-020-832	SLUN-3N (SLUN-3)	ABS/Steel	Chrome/Grey	600~900	390~450	2.8~3.8kg	390~425	5set
180-020-833	SLUN-4N (SLUN-4)	ABS/Steel	Chrome/Grey	600~900	390~450	3.8~4.8kg	390~425	5set
180-020-834	SLUN-5N (SLUN-5)	ABS/Steel	Chrome/Grey	600~900	390~450	4.8~5.8kg	390~425	5set

Item Code	Item Name	Guide bar for cabinet width 600mm	Guide bar for cabinet width 900mm
180-120-287	SLUB-535	535	—
180-104-088	SLUB-551	551	—
180-120-288	SLUB-835	—	835
180-100-131	SLUB-851	—	851

# SWING LIFT-UP STAY



# SLU-ELAN

- Patented easy installation includes:
  - Top corner body installation.
  - One touch door bracket.
  - Flexible bar length.
- Compact design.
- Lift-assist function.
- Free stop and soft-close.
- Optional logo plate.

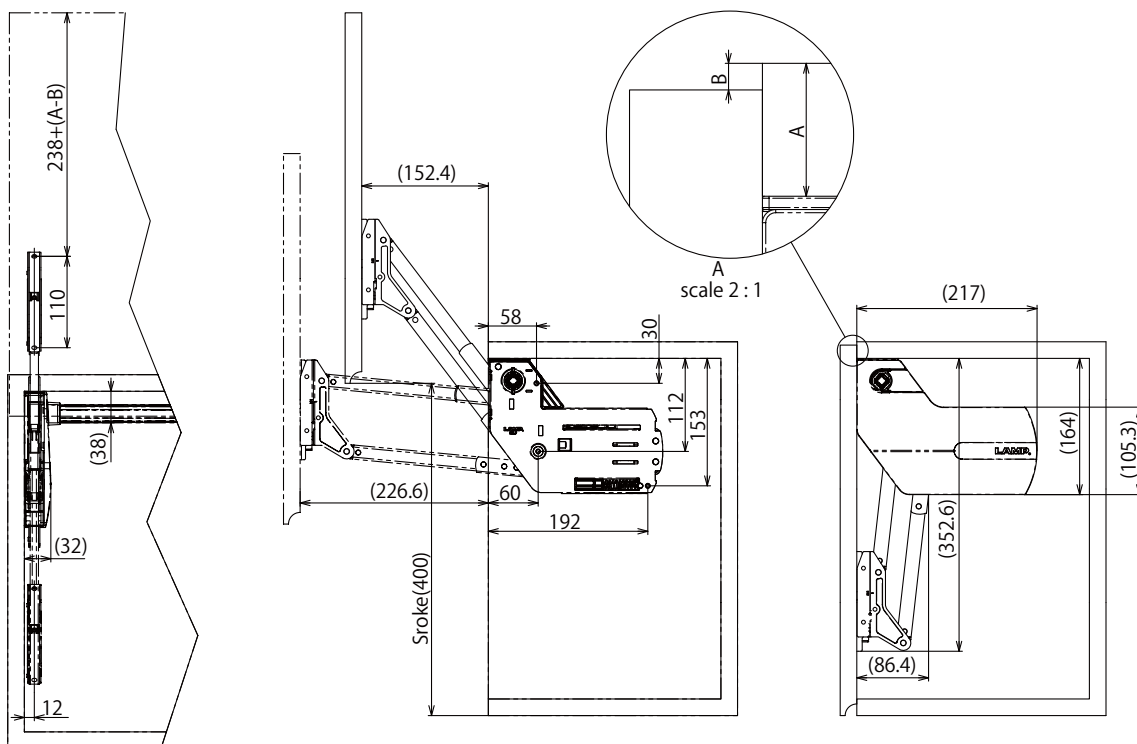
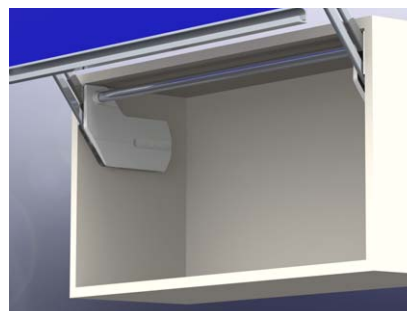
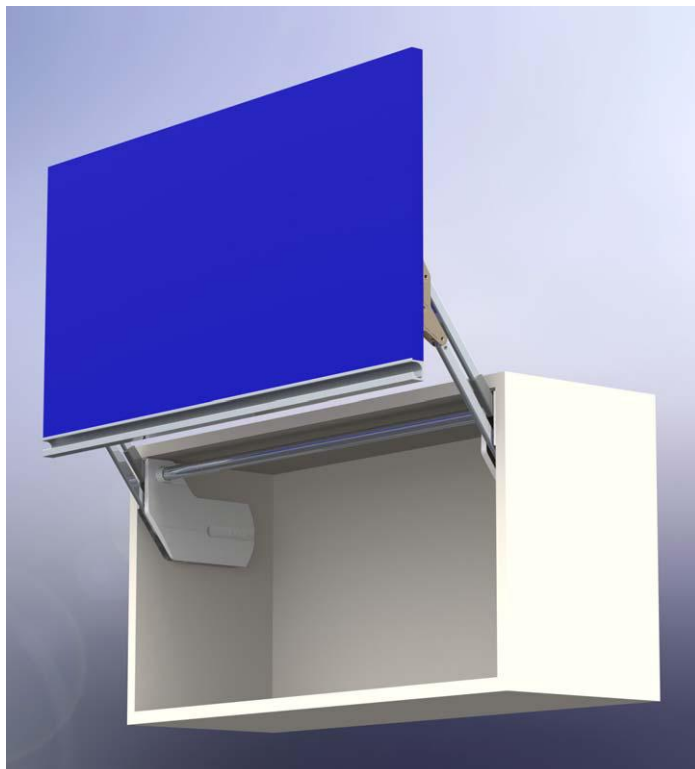

Item Code	Item Name	Door Weight	Door Height	Door Width	Box	Carton
180-022-312	SLU-ELAN S4	5 - 6.5 kg	390 - 500mm	Max. 1800mm	1set	5set
180-022-313	SLU-ELAN L4	6.5 - 8 kg				
180-022-314	SLU-ELAN M4	8 - 9.5 kg				
180-022-315	SLU-ELAN H4	9.5 - 11 kg				

■ Connecting Bar (Sold Separately)

Item Code	Item Name	Cabinet Width	Inside Dimensions
180-022-319	ELB-480	600mm	556-566mm
180-022-320	ELB-780	900mm	856-866mm
180-022-321	ELB-1080	1200mm	1156-1166mm
180-022-322	ELB-1380	1500mm	1456-1466mm
180-026-323	ELB-1680	1800mm	1756-1766mm



# SWING DOWN STAY



SLD



- Unique swing mechanism, provides a lift-assist feature to help open/close the doors with ease & softly.
- Holds the door at opened position.
- Sleek, compact design provides maximum access.
- Easy installation.
- Adjustable arm mounting plate.

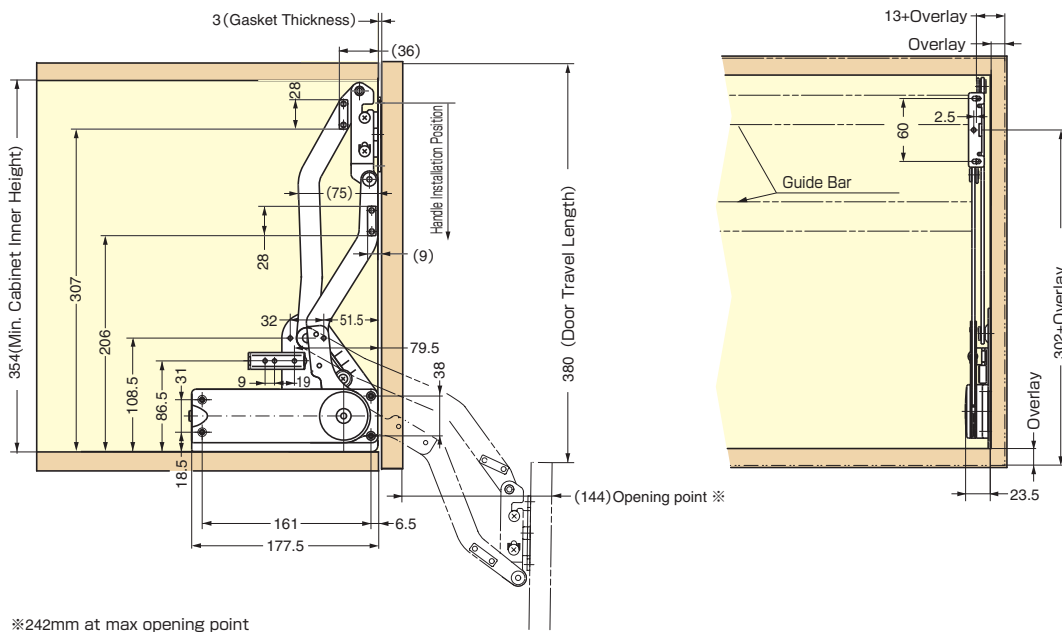
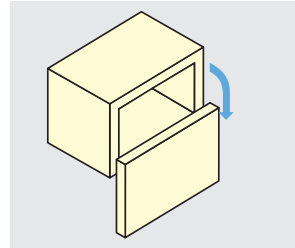

■ Body (set)

Item Code	Item Name	Material	Finish/Color	Door Width	Door Height	Door Weight	Box
180-020-848	SLD-3	ABS/Steel	Chrome/Grey	600 ~ 900	360 ~ 400	3 ~ 4kg	5set
180-020-849	SLD-4	ABS/Steel	Chrome/Grey	600 ~ 900	360 ~ 400	4 ~ 5kg	5set
180-020-850	SLD-5	ABS/Steel	Chrome/Grey	600 ~ 900	360 ~ 400	5 ~ 6kg	5set

■ Guide Bar(Sold separately)

Item Code	Item Name	Door Spec.	Guide bar for cabinet width 600mm	Guide bar for cabinet width 900mm
180-120-287	SLUB-535	Solid wood Door	535	—
180-104-088	SLUB-551	Frame Door	551	—
180-120-288	SLUB-835	Solid wood Door	—	835
180-100-131	SLUB-851	Frame Door	—	851

# HBFN

## HORIZONTAL BI-FOLDING DOOR MECHANISM

- Unique bi-fold door mechanism provides a lift-assist feature to help lift doors and hold at the opened position.
- Compact design with no tracks or guides.
- Easy installation.
- Successfully passed 30,000 open / close private cycle tests.

Designed to operate at room temperature  
0°~40°C (32°~104°F).



# HORIZONTAL BI-FOLDING DOOR MECHANISM



# HBFN

Lid Supports



- Unique bi-fold door mechanism will assist the door open and close in smooth motion.
- Tracks or guides are not required.
- Handle position can be at the bottom of the door.
- Arm length adjustable for various door sizes.
- Patented LAPCON technology provides a smooth and quiet motion.
- Recommended Door Size and Weight:
  - Width, 450~900 mm.
  - Height, 260~370 mm /each door.
  - Weight, 2.5~5.5 kg /each door.

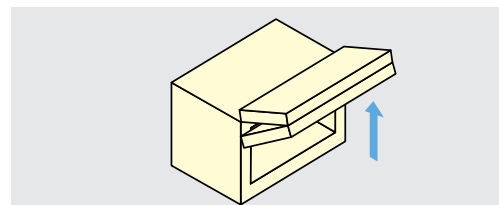
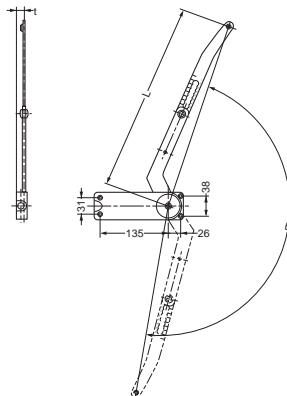

Material	Finish/Color
ABS/Steel	Nickel/Light Grey

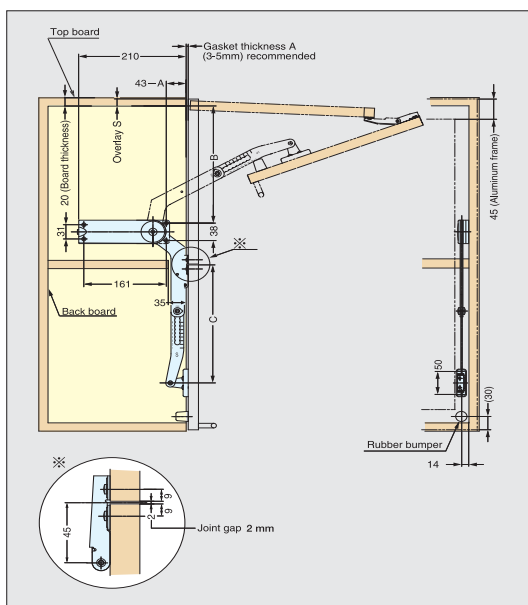

S=Overlay (Top Board)

Type	Door Height (mm)	Opening Angle 90°			Opening Angle 105°		
		Arm Position	B	C	Arm Position	B	C
S	260	1	171-S	189	2	162-S	190
	270	2	176-S	192	3	171-S	195
	280	3	182-S	196	4	180-S	202
	290	4	187-S	199	5	189-S	209
	300	5	192-S	202	6	198-S	216
	310	6	198-S	206	7	207-S	223
	320	7	203-S	209	8	216-S	230
M	320	1	247-S	241	4	226-S	244
	330	2	252-S	244	5	234-S	250
	340	3	258-S	248	6	243-S	257
	350	4	263-S	251	7	251-S	263
	360	5	269-S	255	8	259-S	269
	370	6	274-S	258	9	267-S	275

\*Lift assist version (with "Free Stop" feature) available as special order.

### Body (set)

Item Code	Item Name	Type	Door Width	Door Height	Door Thickness	Door Weight	$\theta$	L	t	Box
180-109-612	※ HBFN-2S	S	450 ~ 900	260 ~ 320	17 ~ 20	2.5 ~ 3.5kg	171°	263 ~ 319	14	10set
180-109-613	※ HBFN-3S	S	450 ~ 900	260 ~ 320	17 ~ 20	3.5 ~ 4.5kg	171°	263 ~ 319	14	10set
180-109-614	※ HBFN-4S	S	450 ~ 900	260 ~ 320	17 ~ 20	4.5 ~ 5.5kg	171°	263 ~ 319	14	10set
180-109-615	HBFN-2M	M	450 ~ 900	320 ~ 370	17 ~ 20	2.5 ~ 3.5kg	171°	299 ~ 363	14	10set
180-109-616	HBFN-3M	M	450 ~ 900	320 ~ 370	17 ~ 20	3.5 ~ 4.5kg	171°	299 ~ 363	14	10set
180-109-617	HBFN-4M	M	450 ~ 900	320 ~ 370	17 ~ 20	4.5 ~ 5.5kg	171°	299 ~ 363	14	10set
180-100-212	※ HBFN-3L	L	450 ~ 900	370 ~ 420	17 ~ 20	2.5 ~ 3.5kg	169°	335 ~ 398.5	14	10set
180-100-213	※ HBFN-4L	L	450 ~ 900	370 ~ 420	17 ~ 20	3.5 ~ 4.5kg	169°	335 ~ 398.5	14	10set
180-100-211	※ HBFN-5L	L	450 ~ 900	370 ~ 420	17 ~ 20	4.5 ~ 5.5kg	169°	335 ~ 398.5	16	10set
180-109-363	※ HBFN-6L	L	450 ~ 900	370 ~ 420	17 ~ 20	5.5 ~ 6.0kg	169°	335 ~ 398.5	16	10set
180-109-318	※ HBFN-7L	L	450 ~ 900	370 ~ 420	17 ~ 20	6.0 ~ 6.5kg	169°	335 ~ 398.5	16	10set

※ Made to order

### Arm Mounting Plate (Sold separately)

Item Code	Item Name	Door Spec.	Box
180-109-618	HBFN-SZ	45mm width aluminum frame door or wood door	100set
-	※ HBFN-AZ-S	20mm width aluminum frame door	40set

※ Made to order

# SPRING LOADED LID STAY



S-YT

- Spring mechanism assists in lifting door and holds in open position.
- Handed: Specific left and right hand mounting.

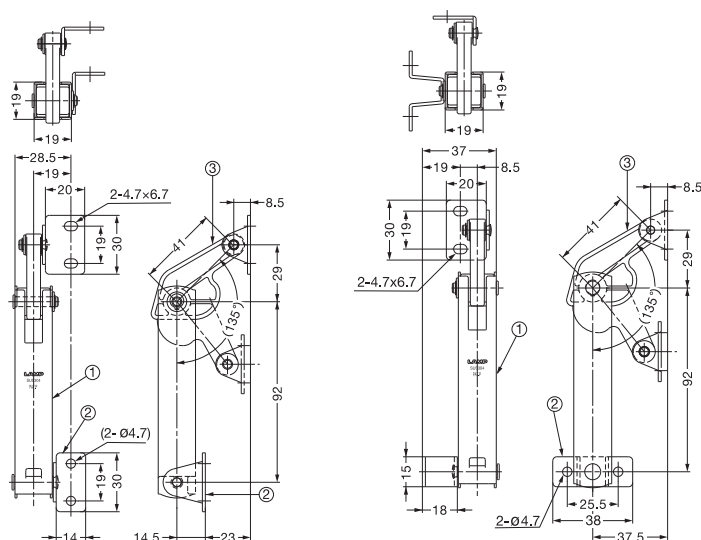

Back panel mount type

Side mount type

Back panel mount type

Side mount type

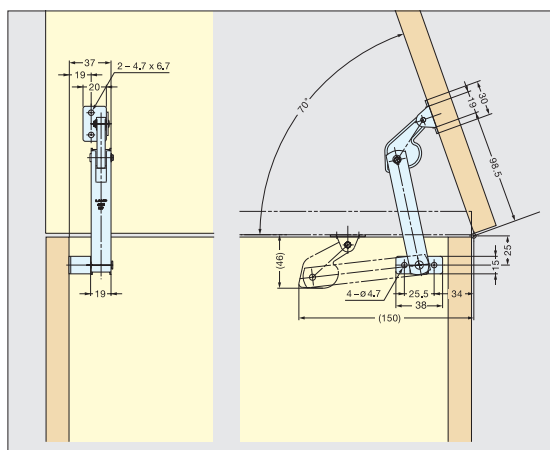
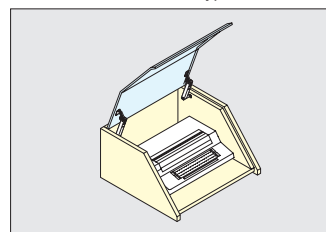
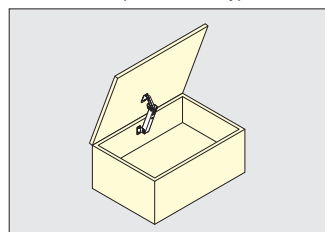

For side mount type

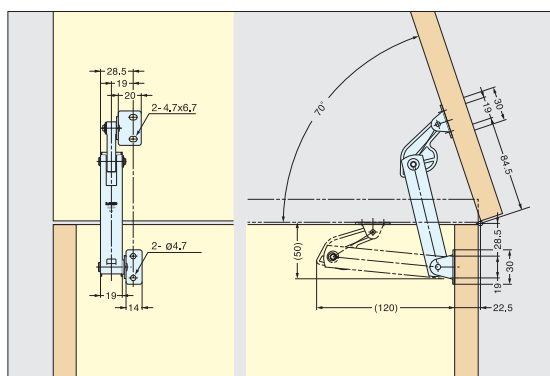

For back panel mount type

No.	Part Name	Material	Finish
①	Body	Stainless Steel (SUS304)	Polished
②	Bracket	Stainless Steel (SUS304)	Polished
③	Arm	Polycetal	-

Item Code	Item Name	Spring Tension	Mounting type	Max. Torque / pc	Weight	Box	Carton
180-100-083	S-YT01R	Soft	Side	30 kgf · cm	118g	10pcs	100pcs
180-100-084	S-YT01L	Soft	Side	30 kgf · cm	118g	10pcs	100pcs
180-100-085	S-YT02R	Hard	Side	40 kgf · cm	118g	10pcs	100pcs
180-100-086	S-YT02L	Hard	Side	40 kgf · cm	118g	10pcs	100pcs
180-100-081	S-YT01S	Soft	Back Panel	30 kgf · cm	118g	10pcs	100pcs
180-100-082	S-YT02S	Hard	Back Panel	40 kgf · cm	118g	10pcs	100pcs

# HEAVY DUTY SPRING LOADED LID STAY



## S-AT

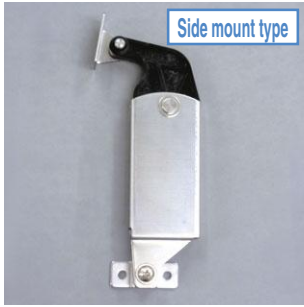

- Spring mechanism assists in lifting door and holds in open position (10°~80°).
- Can be installed individually or in pairs.
- Non-Handed : Can be installed on left or right side.

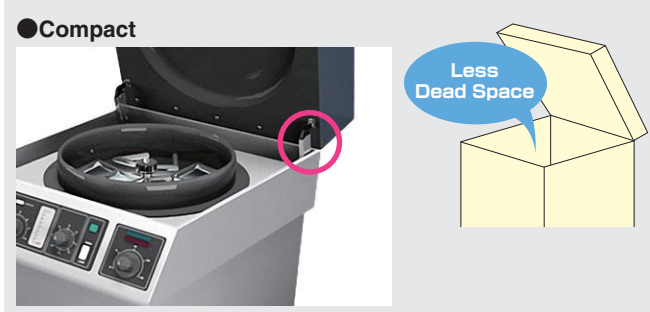

### Selection graph

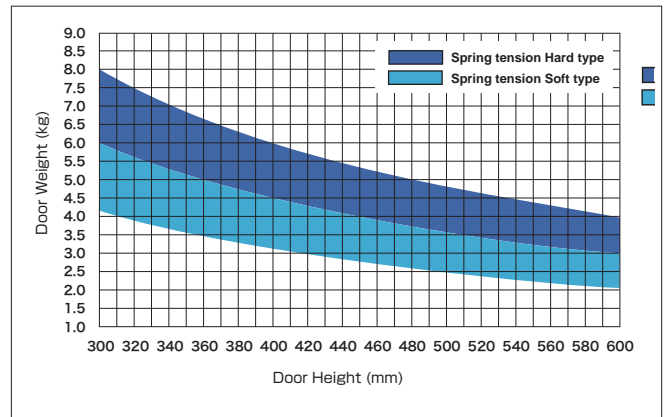

### Torque Calculation:

$$\frac{H(m)}{2} \times W(kg) \times 9.8 = \text{Torque Moment (N}\cdot\text{m)}$$

### S-AT01, S-AT02 (Side mount type)

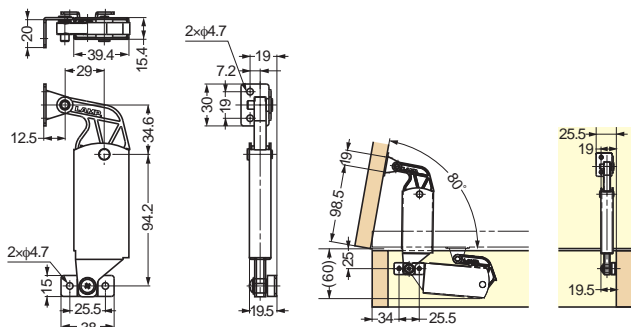

### S-AT01S, S-AT02S (Back panel mount-type)

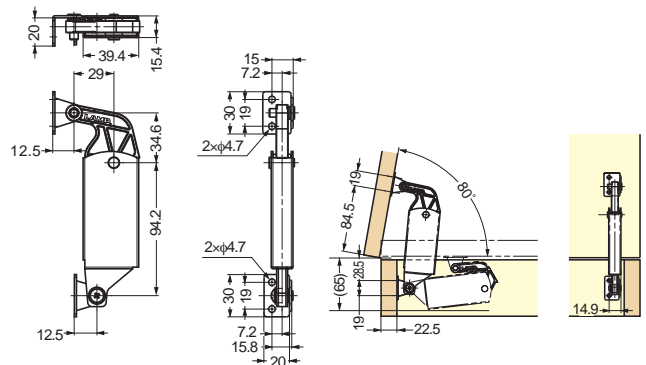

Item Code	Item Name	Material	Finish	Spring Tension	Mounting type	Torque Moment	per pc.	Weight	Box	Carton
180-017-544	S-AT01	Stainless Steel (SUS430)	Plain	Soft	Side	6.1 ~ 8.8 N · m	62 ~ 90 kgf · cm	195 g	10 pcs	50 pcs
180-017-545	S-AT02	Stainless Steel (SUS430)	Plain	Hard	Side	8.8 ~ 11.8 N · m	90 ~ 120 kgf · cm	195 g	10 pcs	50 pcs
180-017-546	S-AT01S	Stainless Steel (SUS430)	Plain	Soft	Back Panel	6.1 ~ 8.8 N · m	62 ~ 90 kgf · cm	195 g	10 pcs	50 pcs
180-017-547	S-AT02S	Stainless Steel (SUS430)	Plain	Hard	Back Panel	8.8 ~ 11.8 N · m	90 ~ 120 kgf · cm	195 g	10 pcs	50 pcs



LK

# LID STAY

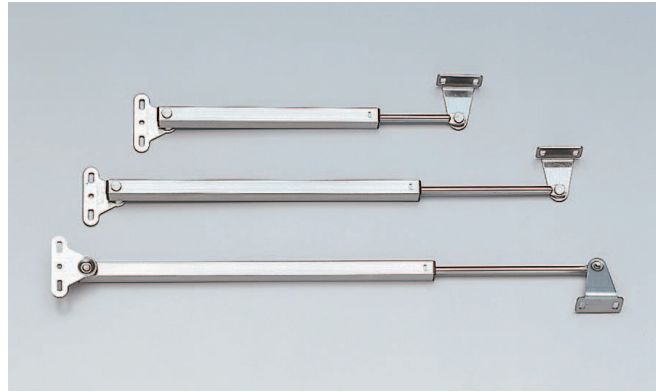

- Spring mechanism assists lifting door and holds in open position.
- Can be installed individually or in pairs.
- Non-Handed: Can be installed on left or right side.
- Load Capacity: 15kg(33 lbs) /each.

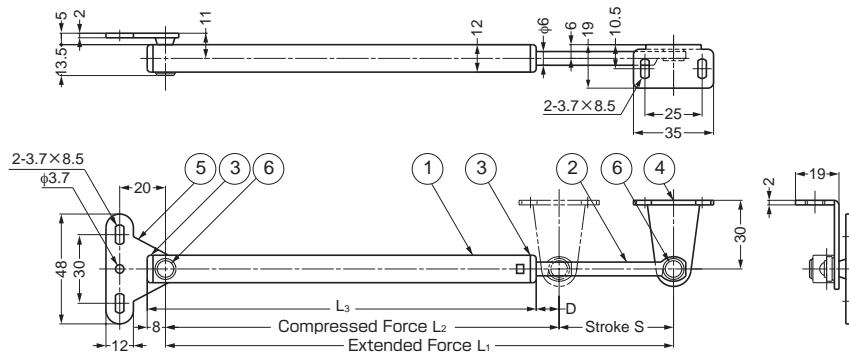

Mounting Example (1) LK-222, LK-335 (Wooden door)

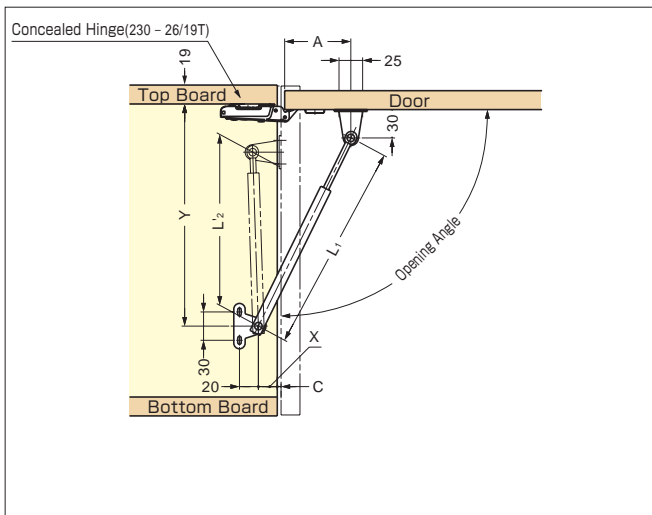

Mounting Example (2) LK-335, LK-380 (Plastic Lid)

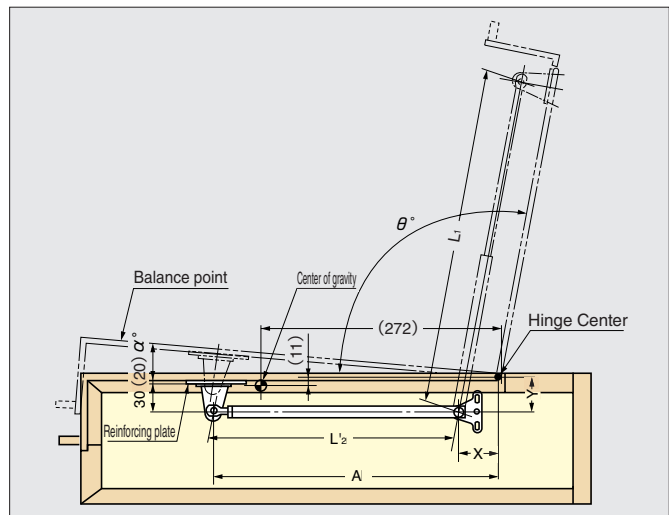

No.	Part Name	Material	Finish
①	Body	Stainless Steel(SUS304)	Satin
②	Arm	Stainless Steel(SUS304)	Polished
③	Cover	Polyamide	Black
④	Bracket	Stainless Steel(SUS304)	Satin
⑤	Bracket	Stainless Steel(SUS304)	Satin
⑥	Shaft	Stainless Steel(SUS303)	—
—	Spring	Piano Wire	Yellow Zinc Chromate

Item Code	Item Name	L <sub>1</sub>	L <sub>2</sub>	L <sub>3</sub>	S	D	Spring Tension		Weight	Box	Carton
							Extended Force	Compressed Force			
180-100-045	LK-222	222	172	170	50	10	3.2kg · f	7.0kg · f	145g	25pcs	150pcs
180-100-046	LK-335	335	250	238	85	20	3.8kg · f	8.5kg · f	185g	25pcs	150pcs
180-100-047	LK-380	380	280	269	100	19	3.6kg · f	8.5kg · f	205g	25pcs	150pcs

	Door Opening	L <sub>1</sub>	A	X	Y	Door Weight
LK-222 (2pcs)	(90)	222	70	20	235	Max.2.5kg
	(85)	222	75	20	240	Max.2.7kg
	(75)	222	85	20	251	Max.3.0kg
	(90)	335	104	20	344	Max.3.1kg
LK-335 (2pcs)	(85)	335	112	20	351	Max.3.3kg
	(75)	335	127	20	368	Max.3.8kg

	Door Opening (θ°)	Door Balance Position (α°)	L <sub>1</sub>	A	X	Y	Door Weight
LK-335 (2pcs)	90	0.5	335	295	45	38	Max.2.5kg
	90	14	335	295	45	38	Max.3.0kg
	85	12	335	295	45	44	Max.3.3kg
LK-380 (2pcs)	110	8	380	330	40	36	Max.2.5kg
	90	3.5	380	335	55	44	Max.3.0kg
	90	4	380	320	41	59	Max.4.0kg
	80	7.5	380	335	56	60	Max.4.3kg

**TORQUE LID STAY (FREE STOP)**   **S-100T30**



- Friction torque lid stay holds lid in desired position.
- Torque Calculation:  
Torque = Door Height x 1/2 x Door Weight.
- Can be installed individually or in pairs.
- Handed: Specific left and right hand mounting.

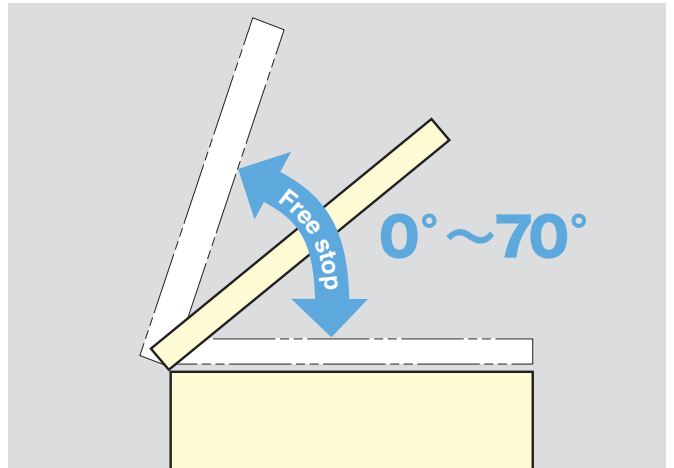
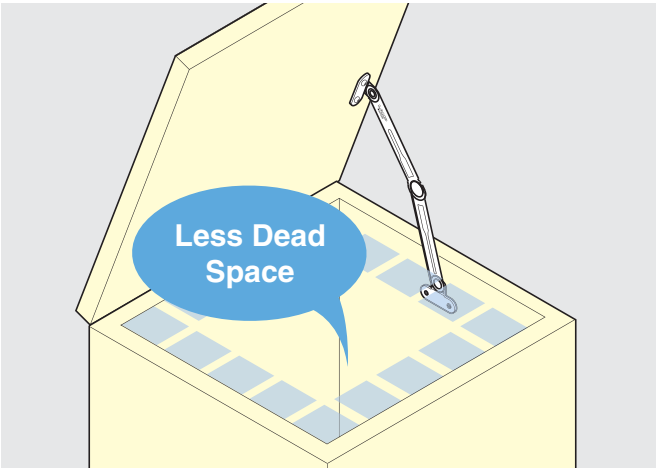
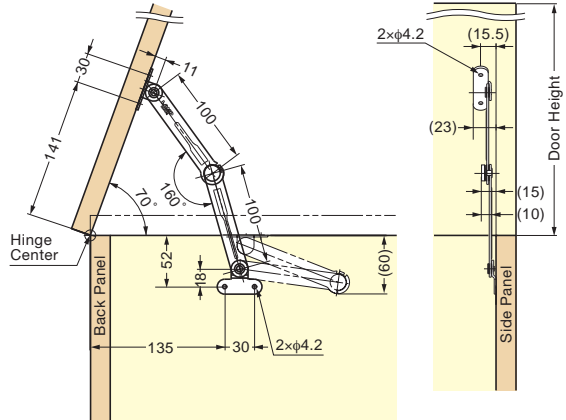

Item Code	Item Name	Material	Finish	Torque Moment(piece)	Torque Moment(pair)	Weight	Box	Carton
180-011-966	S-100T30R	430 Stainless Steel	Plain	30.6kgf.cm ± 20%	61.2kgf.cm ± 20%	100g	30pcs	120pcs
180-011-967	S-100T30L							

**TORQUE LID STAY (FREE STOP)**  **S-52T15**



- Friction torque lid stay holds lid in desired position.
- Torque Calculation:  
Torque = Door Height x 1/2 x Door Weight.
- Can be installed individually or in pairs.
- Handed: Specific left and right hand mounting.

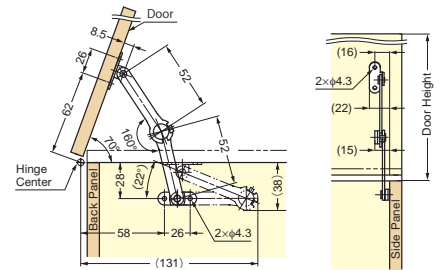

Item Code	Item Name	Spec.	Material	Finish	Torque Moment(piece)
180-023-579	S-52T15R	Right	Stainless Steel (SUS430)	Mirror	1.5 N · m / 15.3 kgf · cm
180-023-580	S-52T15L	Left	Stainless Steel (SUS430)	Mirror	1.5 N · m / 15.3 kgf · cm



# ULTRA MINI LID STAY



# L-100S,L-140S



- Holds lid or panel in opened position.
- Lift up lid to release.
- Non-Handed: Can be installed on left or right side.
- Compact design.
- Can be installed individually or in pairs.
- Mounting brackets (L-S-BT) available as option.

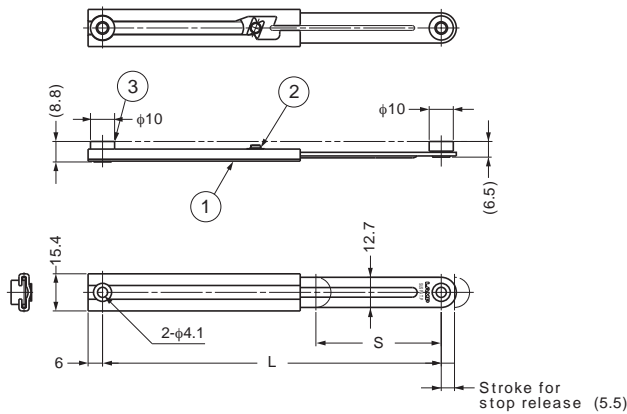

### Installation

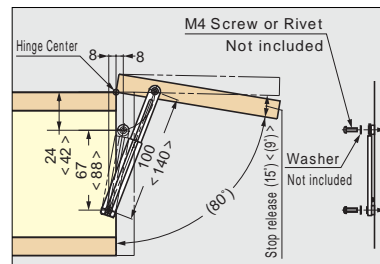

Measurements above in < > are for L-140S

### Stop Release

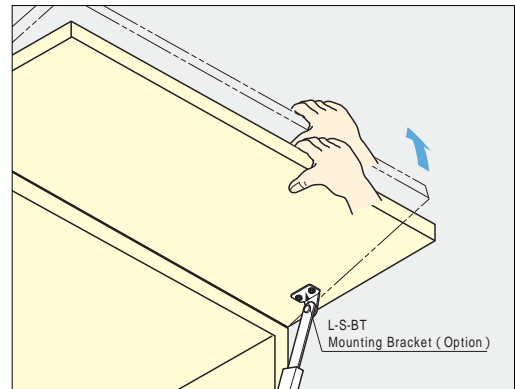

No.	Part Name	Material	Finish
①	Body	Stainless Steel (SUS304)	Polished
②	Washer	Polyamide	—
③	Bracket	Stainless Steel (SUS303)	—

Item Code	Item Name	Load Capacity	L	S	Weight	Box	Carton
180-109-118	L-100S	6 kg	100	32	31g	30pcs	300pcs
180-100-105	L-140S	6 kg	140	52	38g	30pcs	300pcs

# MOUNTING BRACKET



# L-S-BT

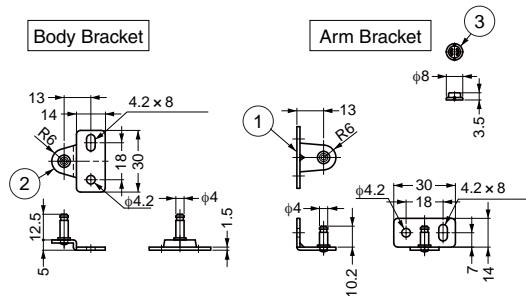

- Optional brackets for L-100S and L-140S stays.
- Brackets for arm and body sold as set.
- Insert the bushing and bracket firmly into the stay.
- \* Do not re-use the bracket. Plastic bushing may become loose once taken off from stay.

No.	Part Name	Material	Finish
①	Arm Bracket	Stainless Steel(SUS304)	Polished
②	Case Bracket	Stainless Steel(SUS304)	Polished
③	Cap	Polyacetal	White

Item Code	Item Name	Weight	Box	Carton
180-100-620	L-S-BT	17g	40set	400set



## MINI LID STAY (W/LOCK)



L-SL140

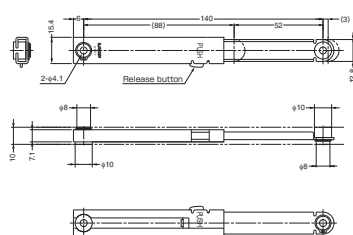

- Automatically locks lid/panel when fully opened.
- Push button to release.
- Can be installed individually or in pairs.
- Non-Handed: Can be installed on left or right side.

### Installation

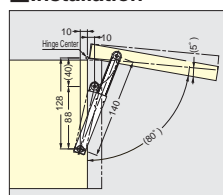

### Release

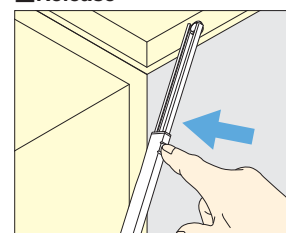

No.	Part Name	Material	Finish
①	Body	Stainless Steel(SUS304)	Polished
②	Arm	Stainless Steel(SUS304)	Polished
③	Case Bracket	Stainless Steel(SUS304)	—
④	Arm Bracket	Stainless Steel(SUS304)	—

Item Code	Item Name	Compression Load	Weight	Box	Carton
180-109-354	L-SL140	147N	15kgf	30pcs	300pcs

## MINI LID STAY (W/LOCK)



L-FS140

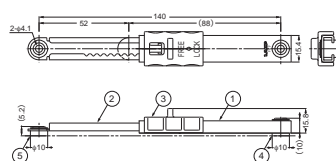

- Locks lid/panel in multiple positions by manually sliding lock lever.
- Slide lever to lock / unlock.
- Can be installed individually or in pairs.
- Non-Handed: Can be installed on left or right side.

### Installation

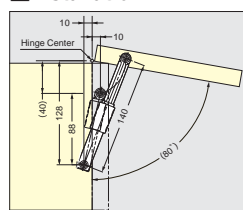

### Lock and Release

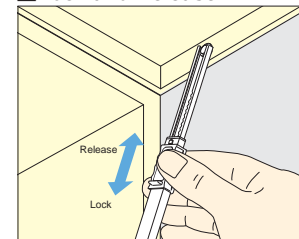

No.	Part Name	Material	Finish
①	Body	Stainless Steel(SUS304)	Polished
②	Arm	Stainless Steel(SUS304)	Polished
③	Lock Lever	Polyacetal	Dark Grey
④	Case Bracket	Stainless Steel(SUS304)	—
⑤	Arm Bracket	Stainless Steel(SUS304)	—

Item Code	Item Name	Compression Load	Weight	Box	Carton
180-100-108	L-FS140	58.8N	6kgf	50g	20pcs

## LOW PROFILE LID STAY



L-200P

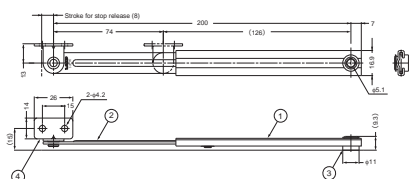

- Holds lid or panel in fully opened position.
- Lift up the lid to release.
- Can be installed individually or in pairs.
- Non-Handed: Can be installed on left or right side.

### Installation

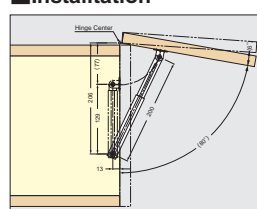

### Stopper Release

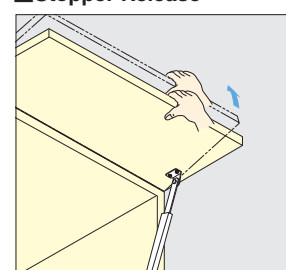

No.	Part Name	Material	Finish
①	Body	Stainless Steel(SUS304)	Polished
②	Arm	Stainless Steel(SUS304)	Polished
③	Case Bracket	Stainless Steel(SUS303)	Plain
④	Arm Bracket (Plate)	Stainless Steel(SUS304)	Polished

Item Code	Item Name	Compression Load	Weight	Box	Carton
180-100-104	L-200P	147N	15kgf	65g	30pcs

# LID STAY



L

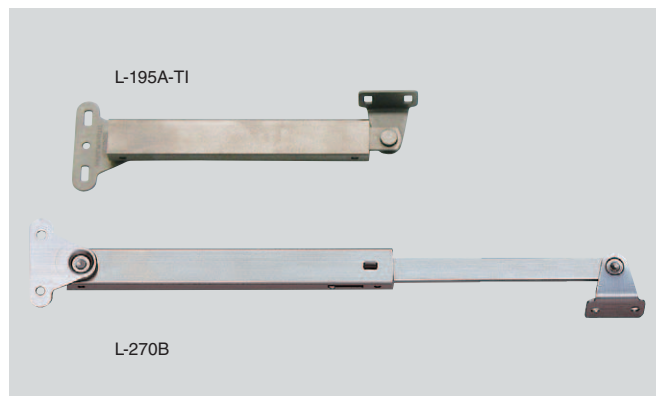

- Holds lid or panel in fully opened position.
- Lift up lid to release.
- Can be installed individually or in pairs.
- Non-Handed: Can be installed on left or right side.
- Load Capacity: 15 kg /each.

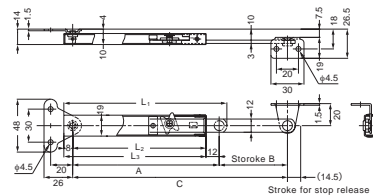

Above drawing shows L-195B or L-270B

### Stpper release

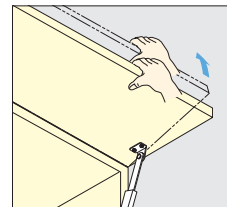

### With Concealed Hinge

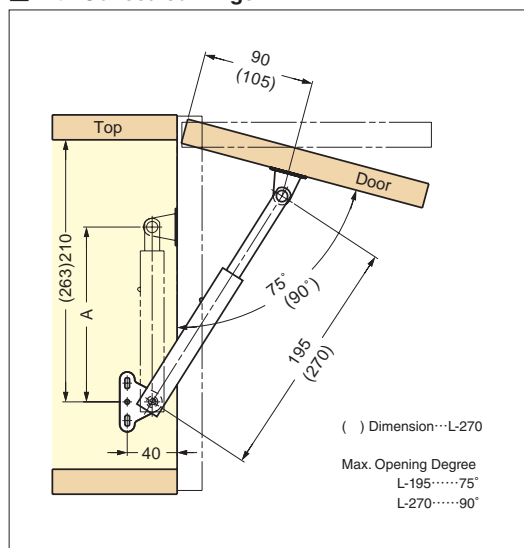

### With Piano / Butt Hinge

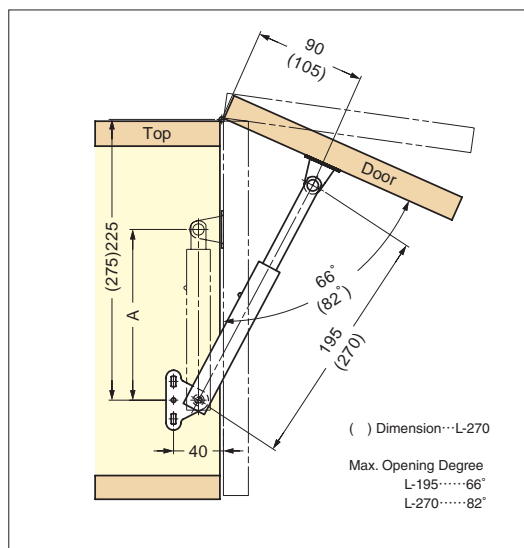

for Door

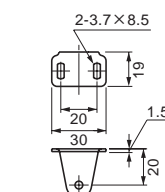

for Side wall

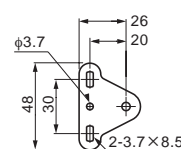

The above dimension for L-195A and L-270A

※Lid must be installed parallel to the sidewall

Item Code	Item Name	Material	Finish	L <sub>1</sub>	L <sub>2</sub>	L <sub>3</sub>	A	B	C	Door Height	Compression Load	Weight	Box	Carton	
180-100-114	L-195A	Stainless Steel (SUS304)	Satin	148	121	129	133	62	195	250~350	147N	15kgf	120g	10pcs	100pcs
180-100-115	L-195B	Stainless Steel (SUS304)	Satin	148	121	129	133	62	195	250~350	147N	15kgf	122g	10pcs	100pcs
180-100-118	L-195A-TI	Titanium	Satin	148	121	129	133	62	195	250~350	147N	15kgf	71g	10pcs	100pcs
180-100-116	L-270A	Stainless Steel (SUS304)	Satin	185	158	166	170	100	270	250~350	147N	15kgf	151g	10pcs	100pcs
180-100-117	L-270B	Stainless Steel (SUS304)	Satin	185	158	166	170	100	270	250~350	147N	15kgf	184g	10pcs	100pcs
180-100-119	L-270A-TI	Titanium	Satin	185	158	166	170	100	270	250~350	147N	15kgf	87g	10pcs	100pcs

# LID STAY (W/LOCK)



LSP



### Installation

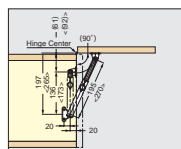

- Automatically locks lid when fully opened.
- Pull the locking knob to release lock.
- Ideal for vibration or shock applications.
- Can be installed individually or in pairs.
- Non-Handed: Can be installed on left or right side.

### Release

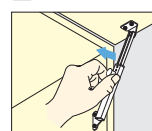

※Lid must be installed parallel to the sidewall

< > Dimension...LSP-270B

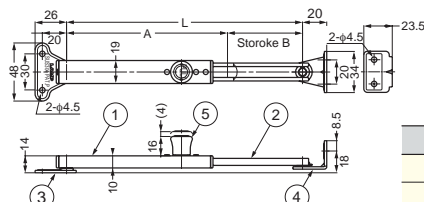

No.	Part Name	Material	Finish
①	Body	Stainless Steel (SUS304)	Satin
②	Arm	Stainless Steel (SUS304)	Satin
③	Case Bracket	Stainless Steel (SUS304)	Satin
④	Arm Bracket	Stainless Steel (SUS304)	Satin
⑤	Locking Knob	Polyacetal	Dark Grey

Item Code	Item Name	L	(A)	B	Compression Load	Box	Carton	
180-100-358	LSP-195B	195	133	62	294N	30kgf	6pcs	60pcs
180-100-357	LSP-270B	270	170	100	294N	30kgf	6pcs	60pcs

# LID STAY

TEST LOAD CAPACITY 20~30 kgf NO SCREW STAINLESS 304 STEEL LB



- Holds lid or panel in fully opened position.
- Lift up lid to release.
- Can be installed individually or in pairs.
- Non-Handed: Can be installed on left or right side.

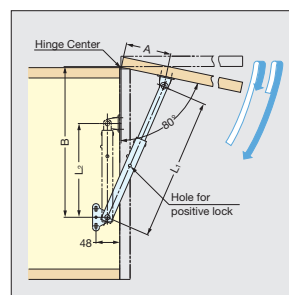
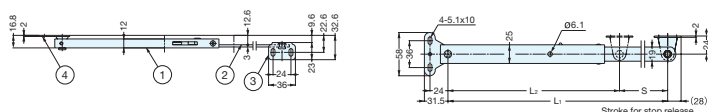

No.	Part Name	Material	Finish
①	Housing	304 Stainless Steel	Plain
②	Arm		
③	Housing Bracket		
④	Arm Bracket		

Item Code	Item Name	L <sub>1</sub>	L <sub>2</sub>	S	A	B	Weight	Compression Load	Box	Carton
180-014-929	LB-200A	200	(155)	45	56	219	235g	30kgf	10pcs	40pcs
180-100-122	LB-350A	350	(230)	120	128	364	314g	25kgf	10pcs	40pcs
180-014-928	LB-500A	500	(305)	195	195	510	400g	20kgf	10pcs	20pcs

# LID STAY

TEST LOAD CAPACITY 15 kgf STAINLESS 304 STEEL LB-215, 290



- Holds lid or panel in fully opened position.
- Can be installed individually or in pairs.
- Non-Handed: Can be installed on left or right side.
- Load Capacity: 15kg /each.

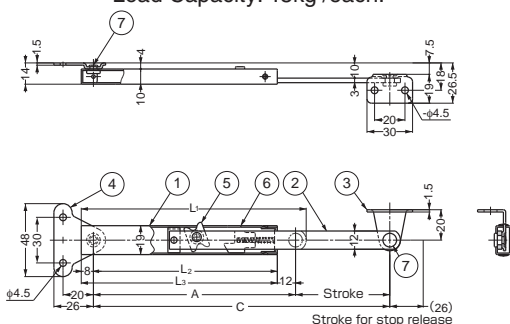

The above dimension for LB-215B and LB-290B.  
( ) Dimension...L-290

### ■Installaton

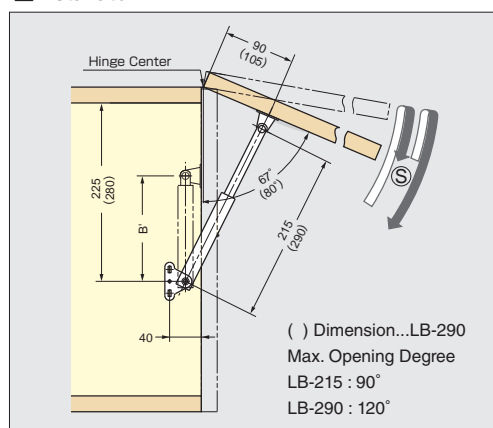

※Lid stay must be installed parallel to the side wall.

### ■Stopper Release

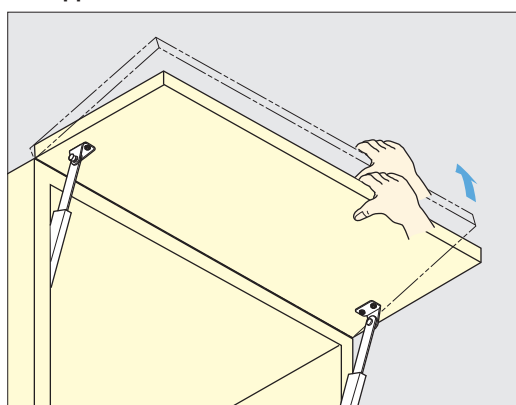

#### Bracket for Door

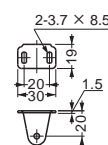

#### Bracket for Side wall

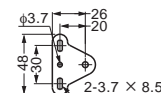

The aboved dimension for LB-215A and LB-290A.

No.	Part Name	Material	Finish
①	Body	Stainless Steel (SUS304)	Satin
②	Arm	Stainless Steel (SUS304)	Satin
③	Bracket	Stainless Steel (SUS304)	Satin
④	Bracket	Stainless Steel (SUS304)	Satin
⑤	Rotor	Stainless Steel (SUS304)	-
⑥	Slide Parts	Zinc Alloy	Chrome
⑦	Axis	Stainless Steel	-

Item Code	Item Name	L <sub>1</sub>	L <sub>2</sub>	L <sub>3</sub>	A	B	C	Door Height	Weight	Compression Load	Box	Carton
180-100-110	LB-215A	168	141	149	153	62	215	260 ~ 350mm	140g	147N 15kgf	10pcs	100pcs
180-100-112	LB-215B	168	141	149	153	62	215	260 ~ 350mm	140g	147N 15kgf	10pcs	100pcs
180-100-120	LB-290A	205	178	186	190	100	290	340 ~ 500mm	160g	147N 15kgf	10pcs	100pcs
180-100-121	LB-290B	205	178	186	190	100	290	340 ~ 500mm	160g	147N 15kgf	10pcs	100pcs

# HEAVY DUTY LID STAY

LOAD CAPACITY  
97~133 kgf

NO SCREW

STAINLESS  
304  
STEEL

LB-S



- Heavy duty lid stay holds.
- Lid or panel in fully opened position.
- Lift up the lid to release.
- Can be installed individually or in pairs.
- Non-Handed: Can be installed on left or right side.

### Installation

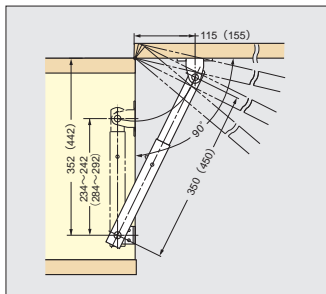

Measurements above in ( ) are for LB-S450

### Stopper Release

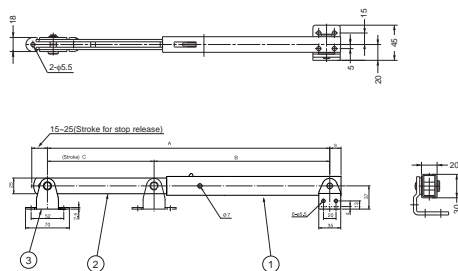
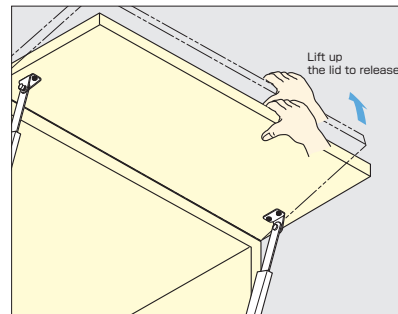

No.	Part Name	Material	Finish
①	Body	Stainless Steel(SUS304)	Satin
②	Arm	Stainless Steel(SUS304)	Satin
③	Arm Bracket	Stainless Steel(SUS304)	Mirror
④	Bracket	Stainless Steel(SUS304)	Mirror

Item Code	Item Name	A	B	C	Compression Load	Weight	Box	Carton
180-100-168	LB-S350	350	230	120	1307N	133kgf	745g	5pcs 20pcs
180-100-169	LB-S450	450	280	170	953N	97kgf	865g	5pcs 20pcs

# HEAVY DUTY MULTI-ANGLE LID STAY

TEST

LOAD CAPACITY  
70 kgf

NO SCREW

STAINLESS  
304  
STEEL

LBTS

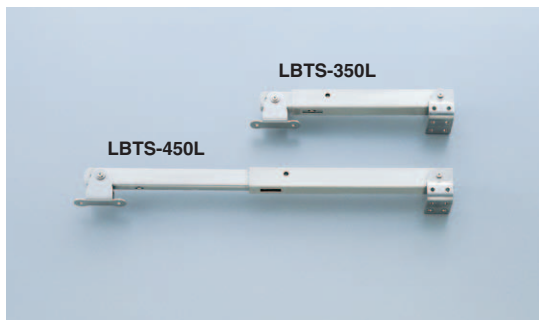

- Ratchet stay holds lid at multiple angles.
- Fully lift up lid to release.
- Can be installed individually or in pairs.
- Non-Handed: Can be installed on left or right side.

### Installation

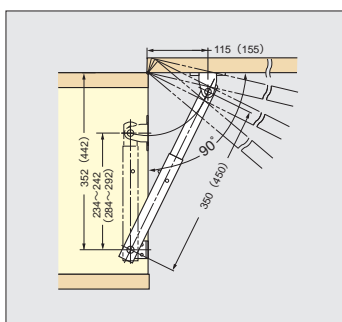

( )...LBTS-450

### Stopper Release

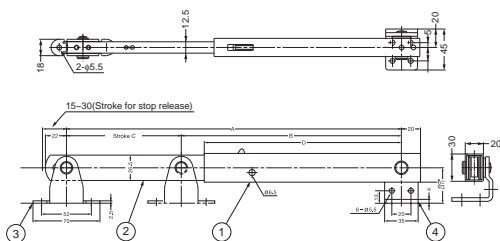
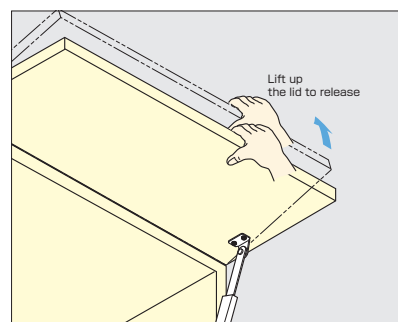

No.	Part Name	Material	Finish
①	Body	Stainless Steel(SUS304)	Satin
②	Arm	Stainless Steel(SUS304)	Satin
③	Arm Bracket	Stainless Steel(SUS304)	Mirror
④	Bracket	Stainless Steel(SUS304)	Mirror

Item Code	Item Name	Spec.	Stop Positions	A	B	C	D	Compression Load	Weight	Box	Carton
180-109-404	LBTS-350R	Right	4	350	230	120	206	686N	70kgf	715g	5pcs 20pcs
180-109-403	LBTS-350L	Left	4	350	230	120	206	686N	70kgf	715g	5pcs 20pcs
180-109-406	LBTS-450R	Right	6	450	280	170	256	686N	70kgf	820g	5pcs 20pcs
180-109-405	LBTS-450L	Left	6	450	280	170	256	686N	70kgf	820g	5pcs 20pcs

## LID STAY (CLEAN ROOM)

LOAD CAPACITY  
15 kgf

NO SCREW

STAINLESS  
304  
STEEL

## LB-CV215A

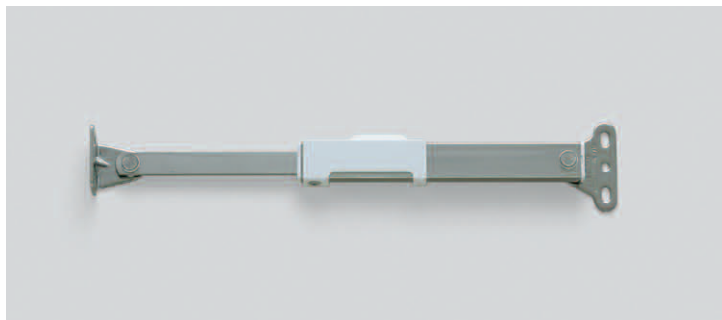

- Holds lid or panel in fully opened position.
- Plastic bushing and end cap minimizes particles.
- No metal-to-metal contact.
- Ideal for cleanroom, semiconductor and food industry applications.
- Can be installed individually or in pairs.
- Non-Handed: Can be installed on left or right side.

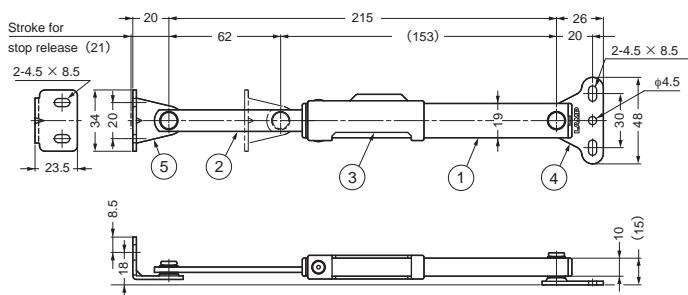

No.	Part Name	Material	Finish
①	Body	Stainless Steel(SUS304)	Polished
②	Arm	Stainless Steel(SUS304)	Polished
③	Cover	ABS	White
④	Case Bracket	Stainless Steel(SUS304)	Polished
⑤	Arm Bracket	Stainless Steel(SUS304)	Polished

### Stopper Release

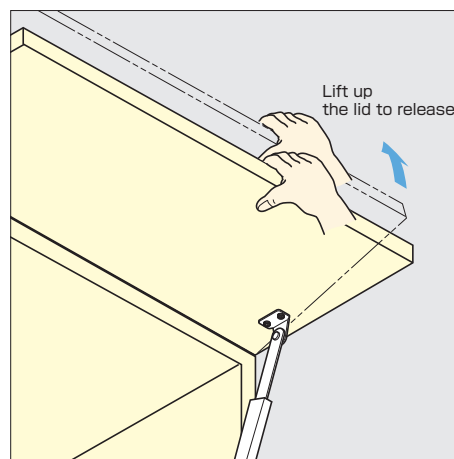

Item Code	Item Name	Compression Load	Weight	Box	Carton
180-100-197	LB-CV215A	147N	15kgf	10 pcs	100 pcs

## MULTI-ANGLE LID STAY (W/LOCK)

LOAD CAPACITY  
30 kgf

NO SCREW

STAINLESS  
304  
STEEL

## L-FS350A



- Locks lid in multiple positions by manually sliding lock lever.
- Slide back lever to lock / unlock.
- Ideal for vibration or shock applications.
- Can be installed individually or in pairs.
- Non-Handed: Can be installed on left or right side.

### Installation

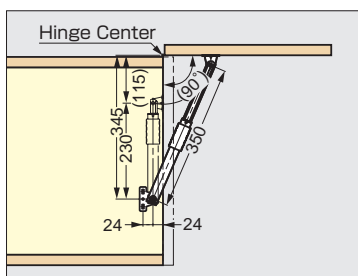

### Stopper Release

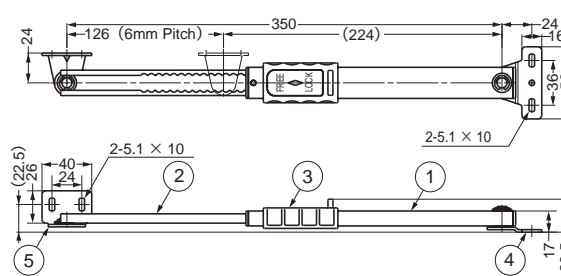
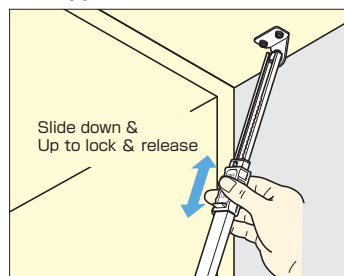

No.	Part Name	Material	Finish/Color
①	Body	Stainless Steel(SUS304)	Satin
②	Arm	Stainless Steel(SUS304)	Satin
③	Lock Lever	Polyacetal	Dark Grey
④	Case Bracket	Stainless Steel(SUS304)	Satin
⑤	Arm Bracket	Stainless Steel(SUS304)	Satin

Item Code	Item Name	Compression Load	Weight	Box	Carton
180-100-617	L-FS350A	294N	30kgf	10 pcs	100 pcs

## MULTI-ANGLE STAY (W/LOCK)

LOAD CAPACITY  
20kgf

## L-FSP350A

Discontinued

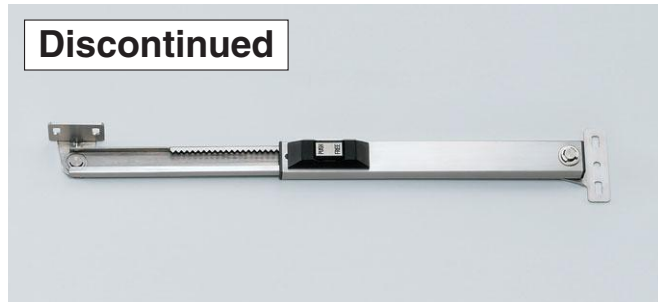

- Locks lid in multiple positions by manually sliding lock lever.
- Slide back lever to lock / unlock.
- Ideal for vibration or shock applications.
- Can be installed individually or in pairs.
- Non-Handed: Can be installed on left or right side.
- Limited stock, contact your local sales for inquiries.

### Installation

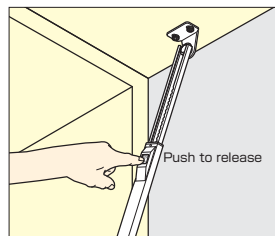
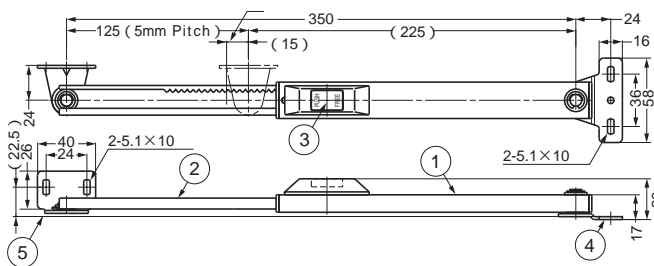
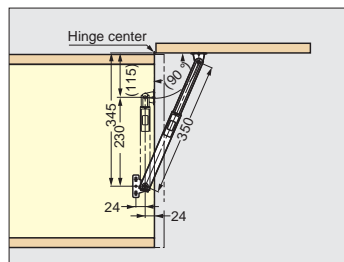

No.	Part Name	Material	Finish
①	Body	Stainless Steel(SUS304)	Satin
②	Arm	Stainless Steel(SUS304)	Satin
③	Push Button	Polyacetal	Dark Grey
④	Case Bracket	Stainless Steel(SUS304)	Satin
⑤	Arm Bracket	Stainless Steel(SUS304)	Satin

Item Code	Item Name	Compression Load	Box	Carton
180-100-619	L-FSP350A	196N	20kgf	5pcs / 50pcs

## MULTI-ANGLE LID STAY

LOAD CAPACITY  
25kgf

## L-FSS350A

Discontinued

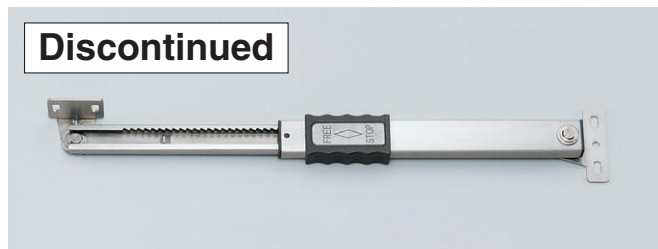

- Locks lid in multiple positions by manually sliding lock lever.
- Slide back lever to lock / unlock.
- Ideal for vibration or shock applications.
- Can be installed individually or in pairs.
- Non-Handed: Can be installed on left or right side.
- Limited stock, contact your local sales for inquiries.

### Installation

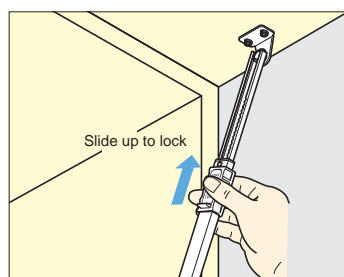
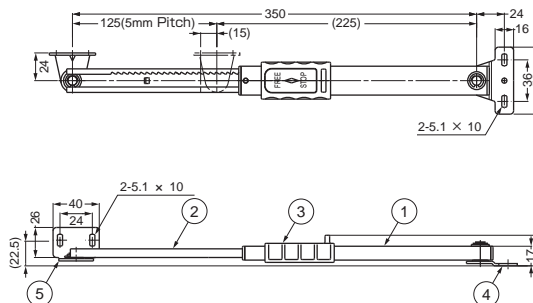
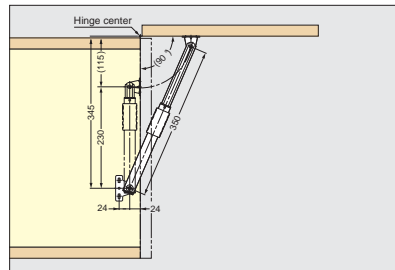

No.	Part Name	Material	Finish/Color
①	Body	Stainless Steel(SUS304)	Satin
②	Arm	Stainless Steel(SUS304)	Satin
③	Lock Lever	Polyacetal	Dark Grey
④	Case Bracket	Stainless Steel(SUS304)	Satin
⑤	Arm Bracket	Stainless Steel(SUS304)	Satin

Item Code	Item Name	Compression Load	Box	Carton
180-100-618	L-FSS350A	245N	25kgf	5pcs / 50pcs

# MULTI-ANGLE LID STAY



## U-3005

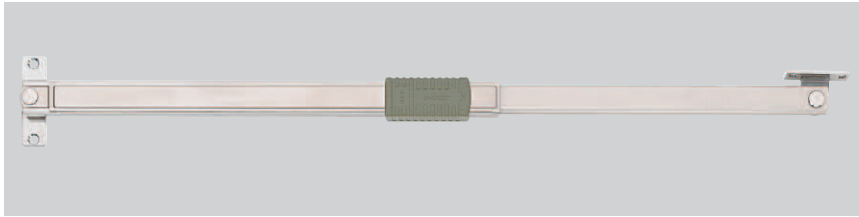

- Locks lid in multiple positions by manually sliding lock lever.
- Slide back lever to lock / unlock.
- Ideal for vibration or shock applications.
- Can be installed individually or in pairs.
- Non-Handed: Can be installed on left or right side.
- Door opening angle : 100° maximum.
- Recommended door size.  
Height – Max. 2,000 mm.  
Width – 600~910 mm.  
Thickness – 25~45 mm.

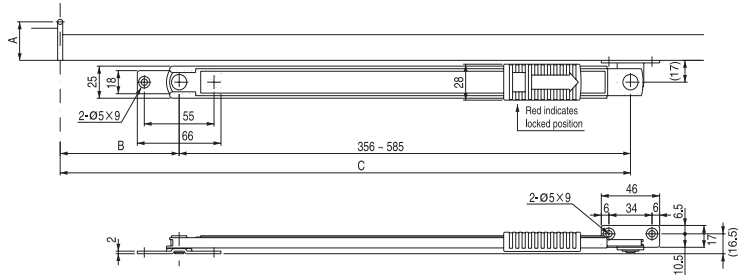

A, B and C dimensions are for 90° door opening angle

A	30	35	40	45	50
B	160	160	160	160	155
C	525	520	515	510	505

Item Code	Item Name	Weight	Box	Carton
180-109-466	U-3005	338g	6pcs	60pcs

Material	Finish/Color
304 Stainless Steel	Satin
Polyacetal	-

# MULTI-ANGLE LID STAY



## U-3031

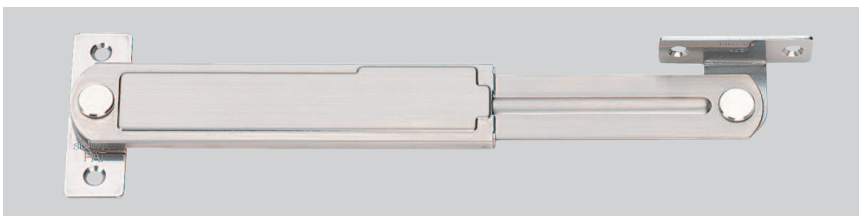

- Ratchet stay holds flap lid at multiple angles.
- Non-handed.
- Thin and compact design.
- Completely open the door to release lock.
- Completely close the door to re-engage the lock.

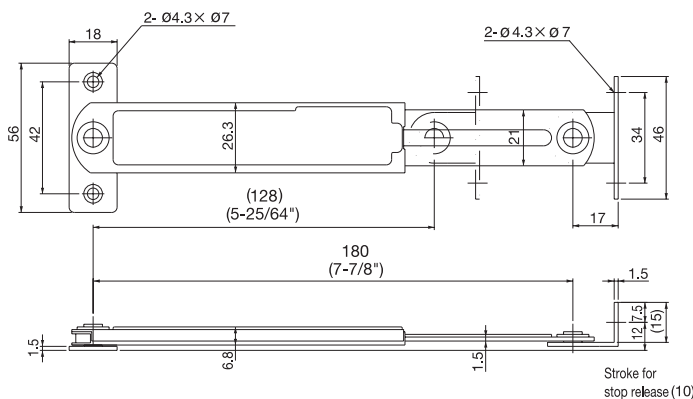

Material	Finish
304 Stainless Steel	Satin

Item Code	Item Name	Stop Positions	Load Capacity	Weight	Box	Carton
180-109-200	U-3031	15	7kg	127g	10pcs	100pcs



HS

LID STAY

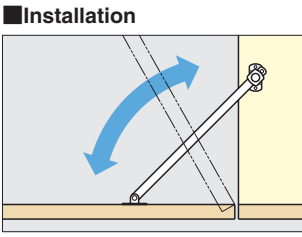
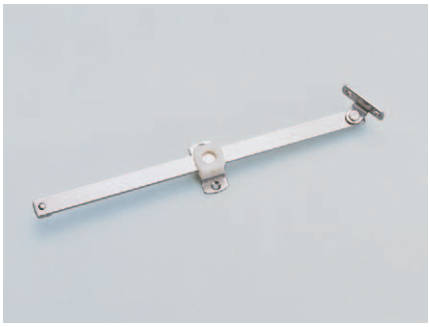

- For downward-opening flap doors.
- Can be installed individually or in pairs.
- Non-Handed: Can be installed on left or right side.

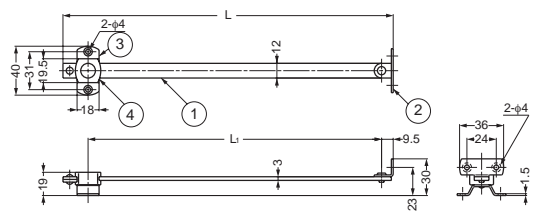

Item Code	Item Name	L	L <sub>1</sub>	Weight	Box	Carton
180-100-020	HS-180	210	180	80g	20pcs	220pcs
180-100-021	HS-210	240	210	90g	20pcs	220pcs
180-100-022	HS-240	270	240	100g	20pcs	220pcs

No.	Part Name	Material	Finish
①	Arm	Stainless Steel(SUS304)	Satin
②	Bracket	Stainless Steel(SUS304)	Satin
③	Mounting Plate	Stainless Steel(SUS304)	Satin
④	Body	Polyamide	White

DOOR STOPPER LID STAY



SAD-160

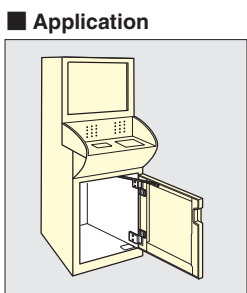

Doorstopper stay can be removed from the door. Horizontal installation for a Sidelong opening use.

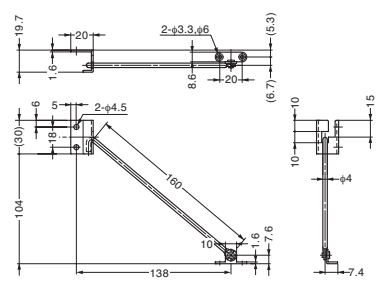
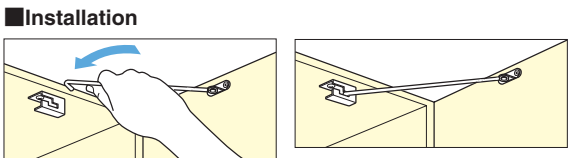

Item Code	Item Name	Material	Finish	Weight	Carton
180-109-185	SAD-160	Stainless Steel (SUS304)	Mirror	34g	500pcs

LID STAY



S-91, 92, 93

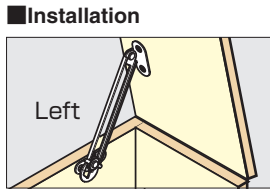
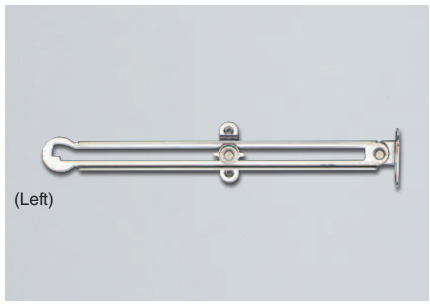

- Automatically holds lid in opened position.
- Lift up lid to release.
- Can be installed individually or in pairs.
- Handed: Specific left and right hand mounting.

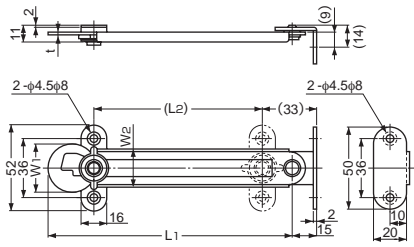

Item Code	Item Name	Spec.	Material	Finish	L <sub>1</sub>	(L <sub>2</sub> )	W <sub>1</sub>	W <sub>2</sub>	t	Load Capacity	Weight	Box
180-100-055	S-91R	Right	304 Stainless Steel	Polished	277	231	30	24	2	40kg	120g	100pcs
180-103-001	S-91L	Left										
180-100-056	S-92R	Right			198	153	28	23	1.5	30kg	85g	30pcs
180-103-002	S-92L	Left										
180-100-057	S-93R	Right			150	105	28	23	1.5	30kg	75g	60pcs
180-100-070	S-93L	Left										



# LID STAY



## F-300



- Keep lids from over extending.
- Can be installed individually or in pairs.
- Non-Handed: Can be installed on left or right side.

### Installation

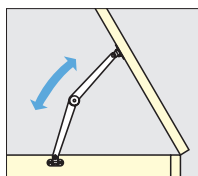

No.	Part Name	Material	Finish
①	Arm	Stainless Steel(SUS304)	Satin
②	Cover	Stainless Steel(SUS304)	BA
③	Plain Washer	Stainless Steel(SUS304)	BA
④	Bracket	Stainless Steel(SUS304)	BA
⑤	Rivet	Steel	Nickel
⑥	Rivet	Brass	Nickel

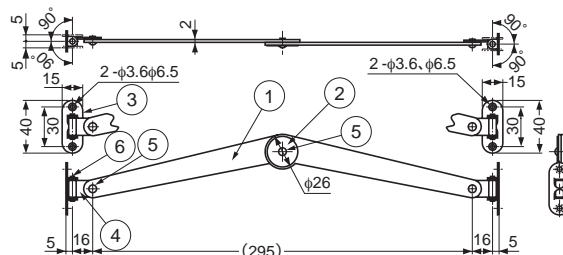

Item Code	Item Name	Weight	Box
180-100-064	F-300	113g	10pcs

# LID STAY



## F-150, 200, 250



### Installation

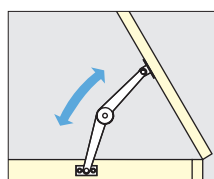

- Keeps lids from over extending.
- Can be installed individually or in pairs.
- Handed: Specific left and right hand mounting.

No.	Part Name	Material	Finish
①	Arm	Stainless Steel(SUS304)	Satin
②	Cover	Stainless Steel(SUS304)	BA
③	Plain Washer	Stainless Steel(SUS304)	BA
④	L Washer	Stainless Steel(SUS304)	BA
⑤	Rivet	Steel	Nickel

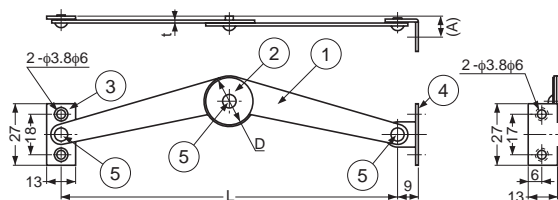

Item Code	Item Name	Spec.	L	D	(A)	t	Weight	Box
180-100-061	F-150R	Right	150	22	9	1.2	30g	40pcs
180-100-067	F-150L	Left						
180-100-062	F-200R	Right	198	22.5	9	1.2	37g	30pcs
180-100-068	F-200L	Left						
180-100-063	F-250R	Right	250	25.5	9	1.5	65g	30pcs
180-100-069	F-250L	Left						

# LID STAY



## F-100

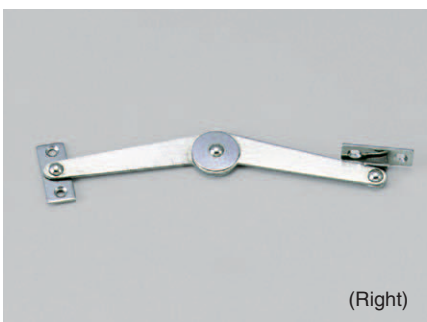

### Installation

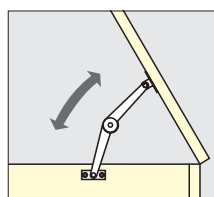

- Keeps lids from over extending.
- Can be installed individually or in pairs.
- Handed: Specific left and right hand mounting.

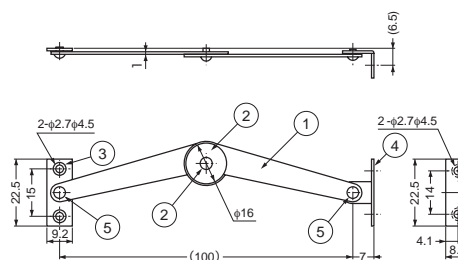

No.	Part Name	Material	Finish
①	Arm	Stainless Steel(SUS304)	Satin
②	Cover	Stainless Steel(SUS304)	BA
③	Plain Washer	Stainless Steel(SUS304)	BA
④	L Washer	Stainless Steel(SUS304)	BA
⑤	Rivet	Steel	Nickel

Item Code	Item Name	Spec.	Weight	Box
180-100-060	F-100R	Right	13g	50pcs
180-100-066	F-100L	Left	13g	50pcs

## LID STAY (W/CATCH)



S-23

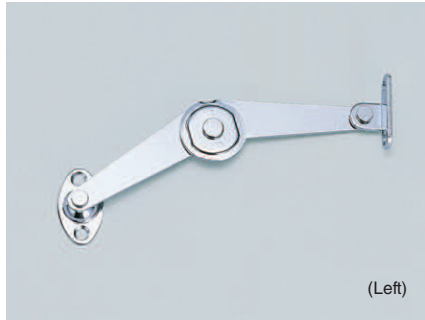

(Left)

- Lid stay with ball catch for light weight doors.
- Catch automatically holds lid in opened position.
- Can be installed individually or in pairs.
- Handed: Specific left and right hand mounting.

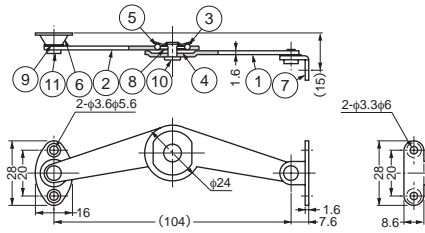

No.	Part Name	Material	Finish
①	BaseA	Steel	Chrome
②	BaseB	Steel	Chrome
③	SpringA	Stainless Steel(SUS301)	—
④	SpringB	Stainless Steel(SUS301)	—
⑤	Balls	Steel	—
⑥	Mounting Plate	Steel	Chrome
⑦	Bracket	Steel	Chrome
⑧	Washer	Steel	Zinc Chromate
⑨	Washer	Polyamide	—
⑩	Center Axis	Brass	Chrome
⑪	Axis	Brass	Chrome

### Installation

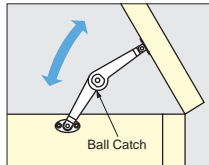

Item Code	Item Name	Spec.	Tension Force	Weight	Box	Carton
180-100-142	S-23R	Right	298N	30.4kgf	33g	50pcs 500pcs
180-100-143	S-23L	Left	298N	30.4kgf	33g	50pcs 500pcs

## LID STAY (W/CATCH)



S-21



(Left)

- Lid stay with ball catch for light weight doors.
- Catch automatically holds lid in opened position.
- Can be installed individually or in pairs.
- Handed: Specific left and right hand mounting.

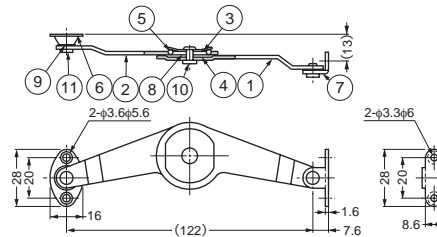

No.	Part Name	Material	Finish
①	BaseA	Steel	Chrome
②	BaseB	Steel	Chrome
③	SpringA	SpringSteel	Chrome
④	SpringB	SpringSteel	—
⑤	Balls	Steel	—
⑥	Mounting Plate	Steel	Chrome
⑦	Bracket	Steel	—
⑧	Washer	Steel	Zinc Chromate
⑨	Washer	Polyamide	—
⑩	Center Axis	Brass	Chrome
⑪	Axis	Brass	Chrome

### Installation

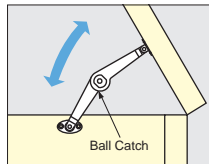

Item Code	Item Name	Spec.	Tension Force	Weight	Box	Carton
180-100-140	S-21R	Right	309N	31.5kgf	49g	50pcs 500pcs
180-100-141	S-21L	Left	309N	31.5kgf	49g	50pcs 500pcs

## LID STAY (W/CATCH)



S-20



(Left)

- Lid stay with ball catch for light weight doors.
- Catch automatically holds lid in opened position.
- Can be installed individually or in pairs.
- Handed: Specific left and right hand mounting.

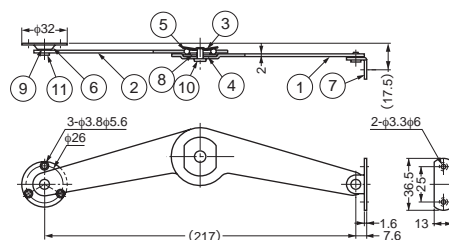

No.	Part Name	Material	Finish
①	BaseA	Steel	Chrome
②	BaseB	Steel	Chrome
③	SpringA	SpringSteel	Chrome
④	SpringB	SpringSteel	—
⑤	Balls	Steel	—
⑥	Bracket	Steel	Chrome
⑦	Bracket(Big)	Steel	Chrome
⑧	Washer	Steel	Zinc Chromate
⑨	Washer	Polyamide	—
⑩	Center Axis	Steel	Chrome
⑪	Axis	Brass	Chrome

### Installation

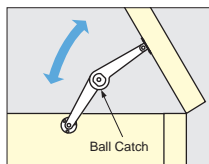

Item Code	Item Name	Spec.	Tension Force	Weight	Box	Carton
180-100-138	S-20R	Right	410N	41.8kgf	122g	40pcs 160pcs
180-100-139	S-20L	Left	410N	41.8kgf	122g	40pcs 160pcs

# FOOT STAYS



YF



- Mechanically locks door when fully opened.
- Simply lift the stay with foot toe to release the lock.
- Designed for bottom mount.
- Non-Handed: Can be installed on left or right side.

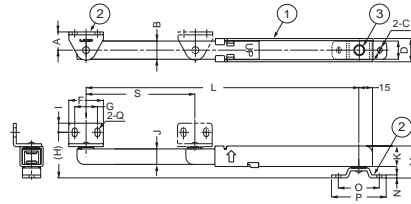
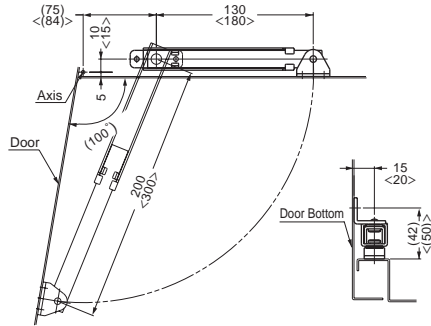

No.	Part Name	Material	Finish
①	Body	Steel	Zinc Chromate
②	Bracket	Steel	Zinc Chromate
③	Shaft	Stainless Steel(SUS304)	—

Item Name	L	S	A	B	C	D	E	F	G	(H)	I	J	K	M	N	O	P	Q
YF-200	200	70	15	15.9	5.5	17	20	33	20	42	8	15.7	20	30	2.3	35	50	5.5x8
YF-300	300	120	20	20	5.5	20	25.5	38	25	50	10	17	22.5	35	3.2	45	60	5.5x9.5
YF-300-T50	300	120	20	20	9	20	25.5	38	25	50	10	17	22.5	35	3.2	50	72	5.5x9.5

Item Code	Item Name	Tension Force	Compression Load	Box	Carton		
180-100-090	YF-200	882N	90kgf	490N	50kgf	10pcs	100pcs
180-100-157	YF-300	1470N	150kgf	588N	60kgf	5pcs	30pcs
180-100-159	YF-300-T50	1470N	150kgf	588N	60kgf	5pcs	30pcs

### Installation

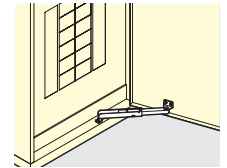

### Lock Release

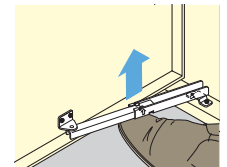

# FOOT STAYS



YF-300W

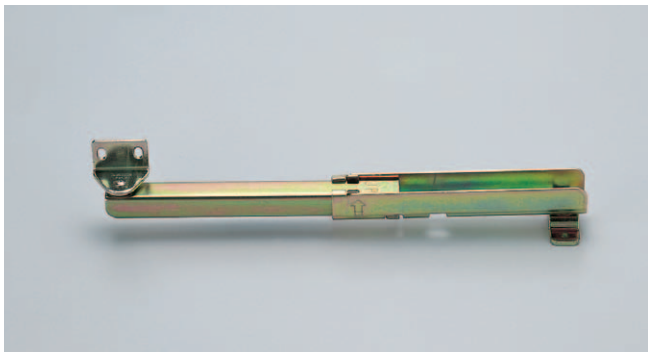

- Mechanically locks door when fully opened.
- Simply lift the stay with foot toe to release the lock.
- Designed for bottom mount.
- Non-Handed: Can be installed on left or right side.

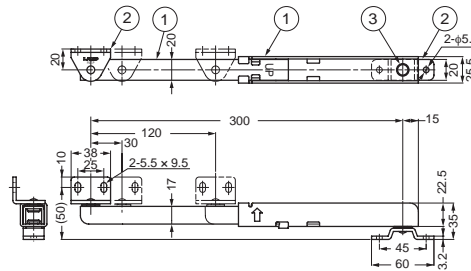
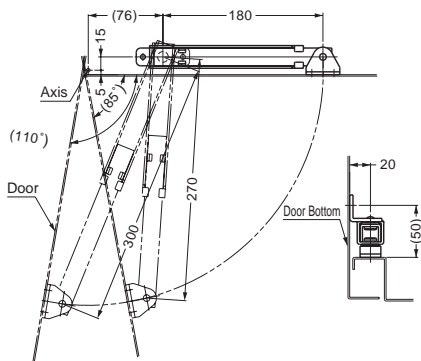

No.	Part Name	Material	Finish
①	Body	Steel	Zinc Chromate
②	Bracket	Steel	Zinc Chromate
③	Shaft	Stainless Steel(SUS304)	—

Item Code	Item Name	Tension Force	Compression Load	Box	Carton		
180-100-158	YF-300W	1470N	150kgf	588N	60kgf	5pcs	30pcs

### Installation

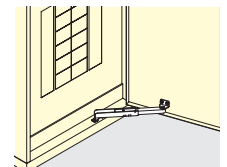

### Lock Release

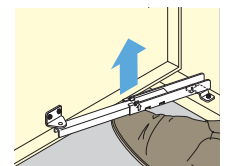

# DOOR HOLDER



## YA-2020

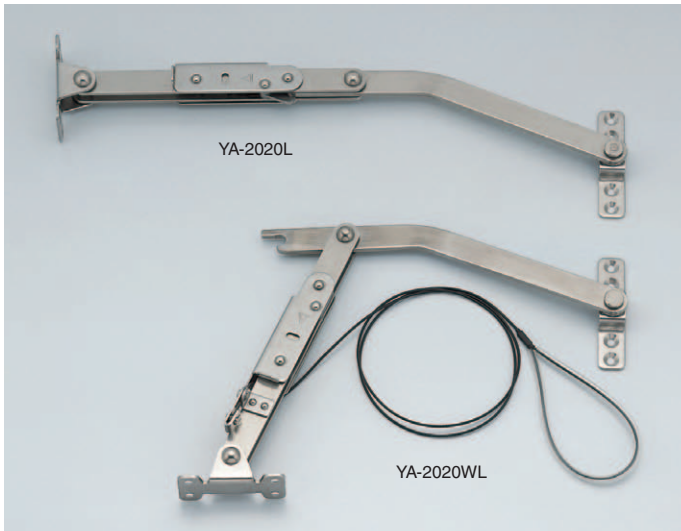

- Automatically locks door when fully opened.
- Slide the locking lever to release lock. Locking grip will keep unlocked until the door is moved for easy handling.
- YA-2020WR/WL (with lock release wire) available for tall application.
- Non-Handed: Can be installed on left or right side.
- Tensile Force : Max. 150kgf
- Compression Load : Max. 60kgf



### ■ YA-2020

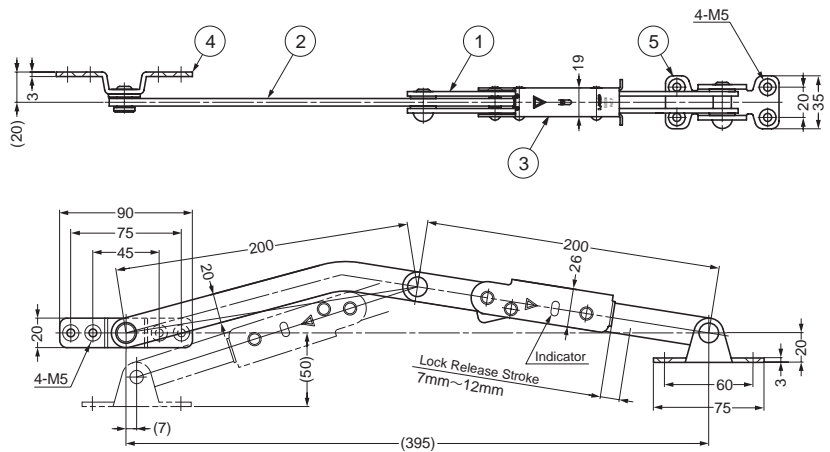

### ■ Installation

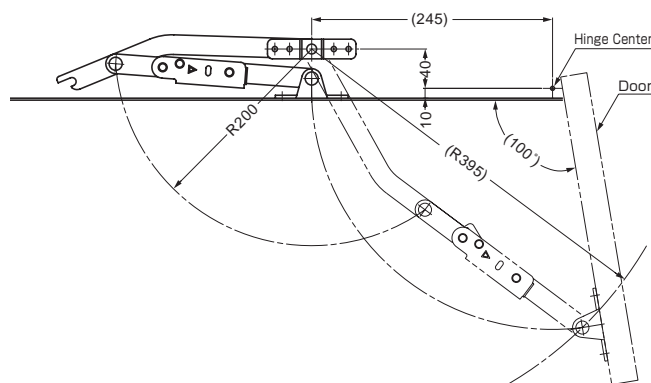

No.	Part Name	Material	Finish
①	Outer Plate	Stainless Steel(SUS304)	Mirror
②	Arm	Stainless Steel(SUS304)	Mirror
③	Slide Grip	Stainless Steel(SUS304)	Mirror
④	Arm Bracket	Stainless Steel(SUS304)	Mirror
⑤	Base Bracket	Stainless Steel(SUS304)	Mirror

Item Code	Item Name	Spec.	Tension Force	Compression Load	Weight	Box	Carton		
180-100-201	YA-2020L	Left	1470N	150kgf	588N	60kgf	630g	4pcs	16pcs
180-100-200	YA-2020R	Right	1470N	150kgf	588N	60kgf	630g	4pcs	16pcs

DOOR HOLDER



YA-0812, 1216

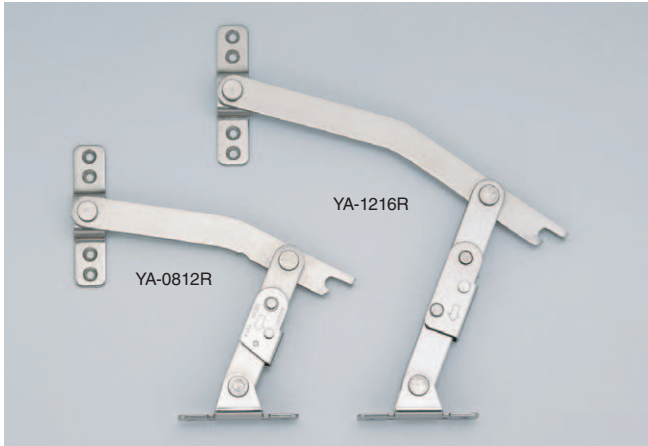

- Automatically locks door when fully opened.
- Slide the locking lever to release lock.  
Lever will keep the unlocked position until the door is moved, for easy handling.
- Left and Right handed available.
- Non-Handed: Can be installed on left or right side.

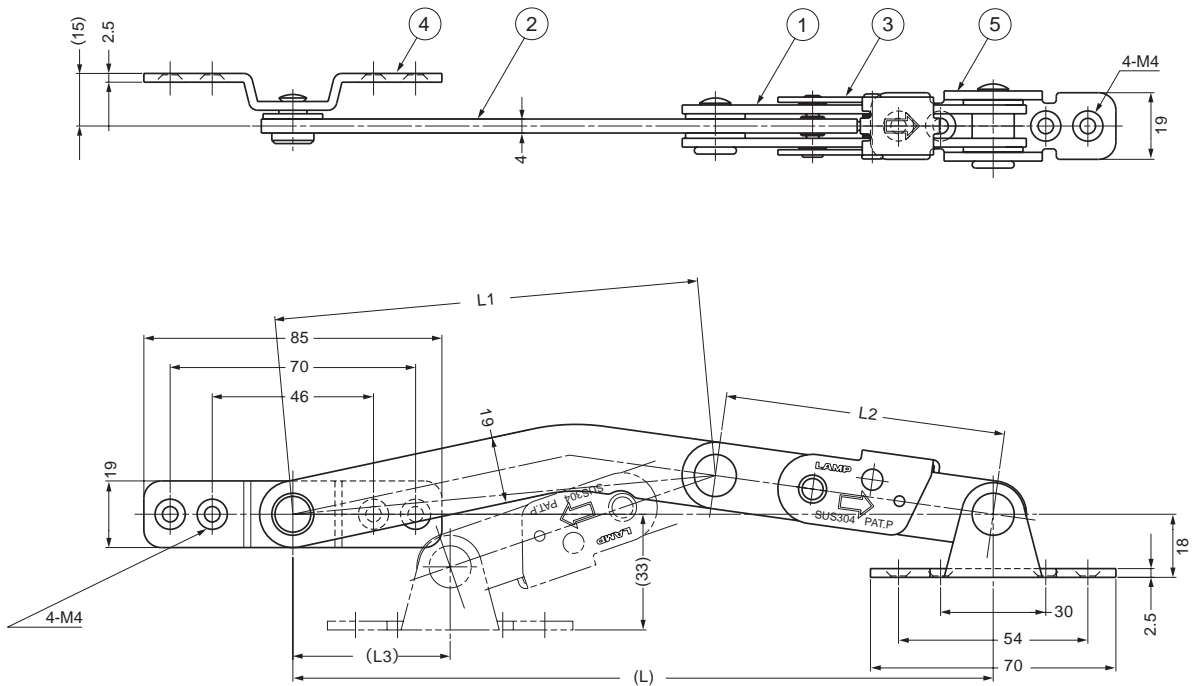

Installation

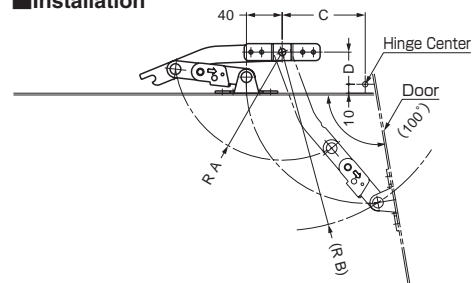

No.	Part Name	Material	Finish
①	Outer Plate	Stainless Steel(SUS304)	Mirror
②	Arm	Stainless Steel(SUS304)	Mirror
③	Slide Grip	Stainless Steel(SUS304)	Mirror
④	Arm Bracket	Stainless Steel(SUS304)	Mirror
⑤	Base Bracket	Stainless Steel(SUS304)	Mirror

Item Code	Item Name	Spec.	L	L <sub>1</sub>	L <sub>2</sub>	L <sub>3</sub>	A	B	C	D	Weight	Box	Carton
180-100-205	YA-0812L	Left	200	121	80	45	121	200	93	36	274g	5pcs	30pcs
180-100-204	YA-0812R	Right	200	121	80	45	121	200	93	36	274g	5pcs	30pcs
180-100-199	YA-1216L	Left	280	161	120	44	161	280	145	40	340g	5pcs	30pcs
180-100-198	YA-1216R	Right	280	161	120	44	161	280	145	40	340g	5pcs	30pcs



## DRAWER SLIDES

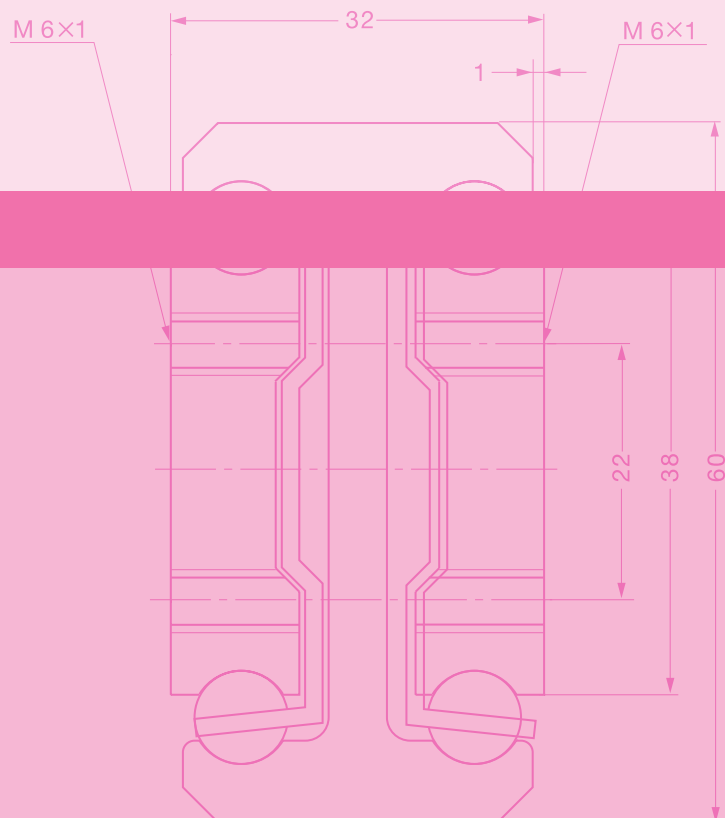
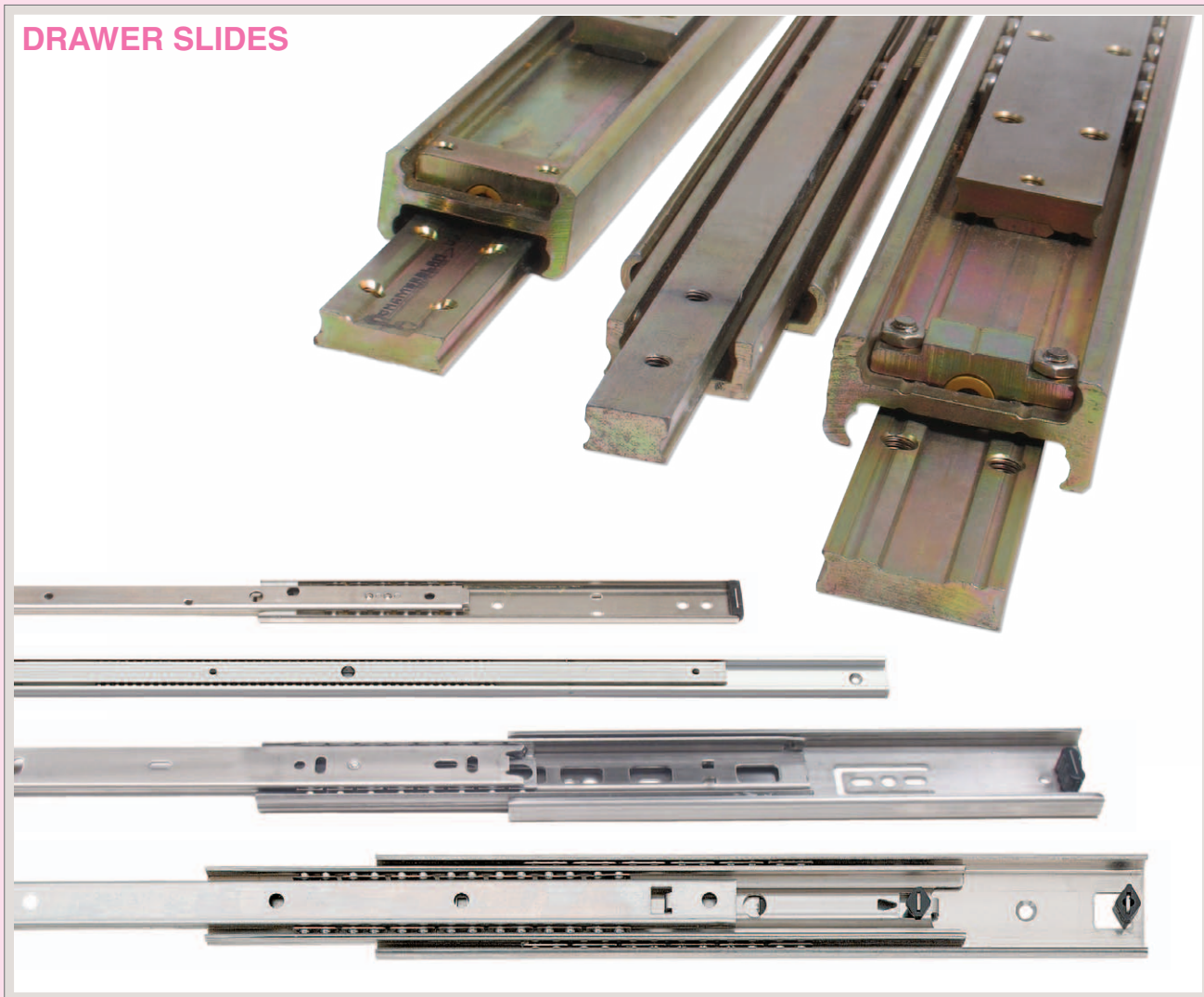

## DRAWER SLIDES



STAINLESS STEEL FULL EXTENSION SLIDES				Hold-In Detent	Hold-Out Detent	Positive Stop	Positive Lock	Positive Catch	Front Disconnect	Friction Brake Stop	Quick Disconnect	Others	Non-Handed
Item Name	Load Capacity (pair)	Page	Side View	Features									
ESR10	182 - 272 kgf	162				●							●
5302	64 - 116 kgf	163		●		●							●
ESR-4513	40 - 52 kgf	164		●		●			●				●
ESR-3813	29 - 45 kgf	165		●		●			●				●
TSS3	50 - 95 kgf	166				●							●
ESR7	36 - 64 kgf	167					●		●				●
SNS35W	36 - 62 kgf	168							●				●
SNS35D	45 - 60 kgf	169				●							●
SNS27D	28 - 38 kgf	170				●							●
273SL	12 - 18 kgf	171				●			●				●
ESR2031	13 - 17 kgf	172				●							●
ESR3	43 - 65 kgf	173				●					●		

### Drawer Slide Terms

- Slide Length .....The longest dimension of a fully closed slide. This dimension cannot exceed the depth of the cabinet into which it is installed.
- Travel .....The distance that a slide moves from the closed to a fully open position.
- ¾ Extension .....The slide extends approximately ¾ of its length from the front edge of the cabinet front. This is the normal travel of 2 member slides.
- Full Extension .....The full withdrawal of a drawer from the case .This is the normal travel of 3 member slides.
- Positive Stop .....Drawer stops at extended/open position, but does not lock or detent.



**STAINLESS STEEL 3/4 EXTENSION SLIDES**

Item Name	Load Capacity (pair)	Page	Side View	Hold-In Detent	Hold-Out Detent	Positive Stop	Positive Lock	Positive Catch	Front Disconnect	Friction Brake Stop	Quick Disconnect	Others	Non-Handed
ESR5	80 - 114 kgf	174				●							●
ESR1	25 - 49 kgf	175							●	●			●
SNS35S	25 - 49 kgf	176				●							●
SNS27S	18 - 26 kgf	177				●							●
272SL	14 - 18 kgf	178				●			●				●
ESR2021	11 - 16 kgf	179				●							●
ESR2	5 - 8 kgf/pcs	180							●	●		Under Mount	

**STEEL FULL EXTENSION SLIDES**

Item Name	Load Capacity (pair)	Page	Side View	Hold-In Detent	Hold-Out Detent	Positive Stop	Positive Lock	Positive Catch	Front Disconnect	Friction Brake Stop	Quick Disconnect	Others	Non-Handed
4070	20 - 45 kgf	184										Soft Close	●
4071	20 - 45 kgf	185										Soft Close	●
4060	20 - 45 kgf	186										Push Open	●
4061	20 - 45 kgf	187										Push Open	●

- Positive Lock .....Drawer is firmly held in the extended/out position. Drawer is released by depressing a lever and pushing the drawer inward. The drawer can also be disconnected by depressing the lever and pulling the drawer outward.
- Friction Brake Stop .....Drawer stops at extended/open position by the resistance of the ball retainer. Usually achieved by deforming the slide races to achieve an interference fit.
- Hold-in Detent .....Drawer is firmly held in the fully closed position. Drawer is released by pulling the drawer outward. This feature is also known as a Positive Catch.
- Front Disconnect .....Drawer member can be disconnected by actuating the disconnect lever.
- Quick Disconnect .....A drawer bracket attaches to the drawer and engages the drawer member of the slide. The drawer can be disconnected by actuating the drawer rail lock, and pulling it outward.



ALUMINUM FULL EXTENSION SLIDES

Item Name	Load Capacity (pair)	Page	Side View	Hold-In Detent	Hold-Out Detent	Positive Stop	Positive Lock	Positive Catch	Front Disconnect	Friction Brake Stop	Quick Disconnect	Others	Non-Handed
				Features									
AR3	15 kgf	188				●							●
AR3-K	12 - 14.5 kgf	188		●		●							●
AR3-16	2 - 4 kgf	190				●							●

ALUMINUM 3/4 EXTENSION SLIDES

Item Name	Load Capacity (pair)	Page	Side View	Hold-In Detent	Hold-Out Detent	Positive Stop	Positive Lock	Positive Catch	Front Disconnect	Friction Brake Stop	Quick Disconnect	Others	Non-Handed
				Features									
AR2	15 kgf	189				●							●
AR2-K	13 - 18 kgf	189		●		●							●

LINEAR SLIDES

Item Name	Load Capacity (pair)	Page	Side View	Hold-In Detent	Hold-Out Detent	Positive Stop	Positive Lock	Positive Catch	Front Disconnect	Friction Brake Stop	Quick Disconnect	Others	Non-Handed
				Features									
TSSL	-	181											●
ESR9	5 kgf	182										Mounting Plate	●
RKA5	15 kgf	183										●	Self Close
ARL2-16	0.8 - 5 kgf	190											●
ARW2-16	1.1 - 7 kgf	190											2-Way ●
MRS20, MR-20CS	Horizontal Static Load: 31 kgf/pcs Vertical Static Load: 18 kgf/pcs	191											●
MRS30, MR-50C	Horizontal Static Load: 26 kgf/pcs Vertical Static Load: 15 kgf/pcs	192											●

CBL HEAVY DUTY SLIDES

Item Name	Load Capacity(pair)	Page	Side View	Item Name	Load Capacity(pair)	Page	Side View	Item Name	Load Capacity(pair)	Page	Side View
CBL-E1908	450 - 950 kgf	193		CBL-E1904	80 - 220 kgf	199		CBL-D444	40 - 50 kgf	206	
CBL-E1708	290 - 565 kgf	193		CBL-RA5R	60 - 150 kgf	200		CBL-D402	15 - 50 kgf	206	
CBL-ST508	100 - 130 kgf	194		CBL-R53	65 - 135 kgf	200		CBL-ST45	30 - 100 kgf	207	
CBL-ST58	50 - 120 kgf	194		CBL-E1400	80 - 130 kgf	201		CBL-E98	400 - 600 kgf	207	
CBL-ST448	40 - 80 kgf	195		CBL-R26	45 - 95 kgf	201		CBL-E46	125 - 250 kgf	208	
CBL-ST658	30 - 45 kgf	195		CBL-RA41	45 - 95 kgf	202		CBL-E72	60 - 160 kgf	208	
CBL-E1020	600 - 1250 kgf	196		CBL-RA554R	55 - 95 kgf	202		CBL-E50	90 - 240 kgf	209	
CBL-E1012	300 - 1000 kgf	196		CBL-RT3D	35 - 65 kgf	203		CBL-E48	85 - 240 kgf	209	
CBL-E1902	250 - 950 kgf	197		CBL-RA44	40 - 80 kgf	203		CBL-E47	30 - 80 kgf	210	
CBL-E1700	290 - 565 kgf	197		CBL-RA31	30 - 52 kgf	204		CBL-E53	55 - 170 kgf	210	
CBL-E1014	150 - 500 kgf	198		CBL-RA654	30 - 45 kgf	204		CBL-E28	20 - 50 kgf	211	
CBL-RA7R	130 - 340 kgf	198		CBL-R20	10 - 39 kgf	205		CBL-D48	25 - 50 kgf	211	
CBL-R71	170 - 310 kgf	199		CBL-D500	40 - 80 kgf	205		CBL-D409	2 - 5 kgf	212	

# FULL EXTENSION SLIDE



# ESR10

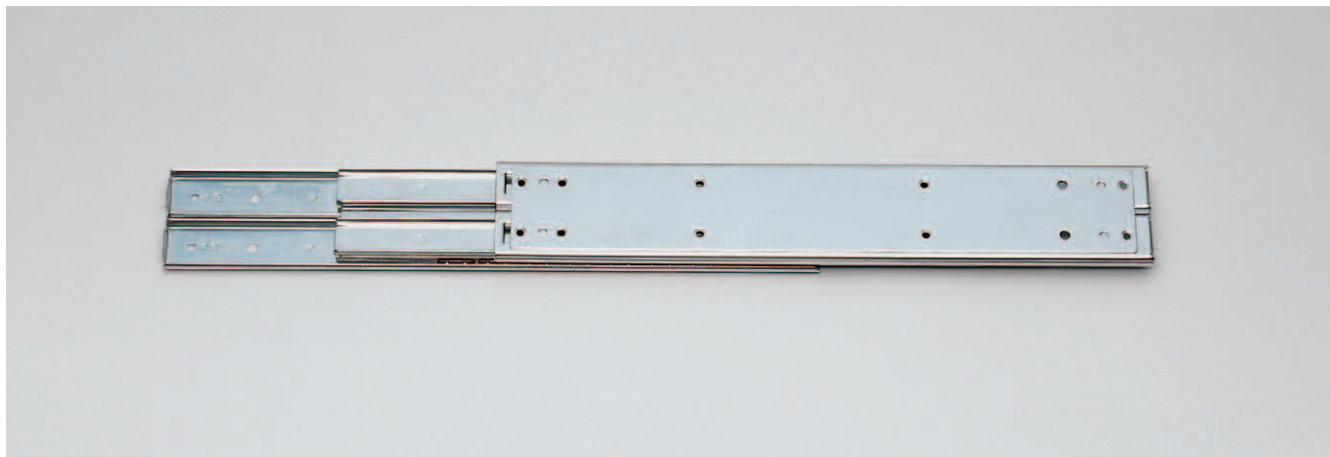

- Full extension.
- Positive stop.
- Non-handed.
- Heavy duty.
- \* Mount with M4 or #8 Binding, Pan, or Truss head screws.

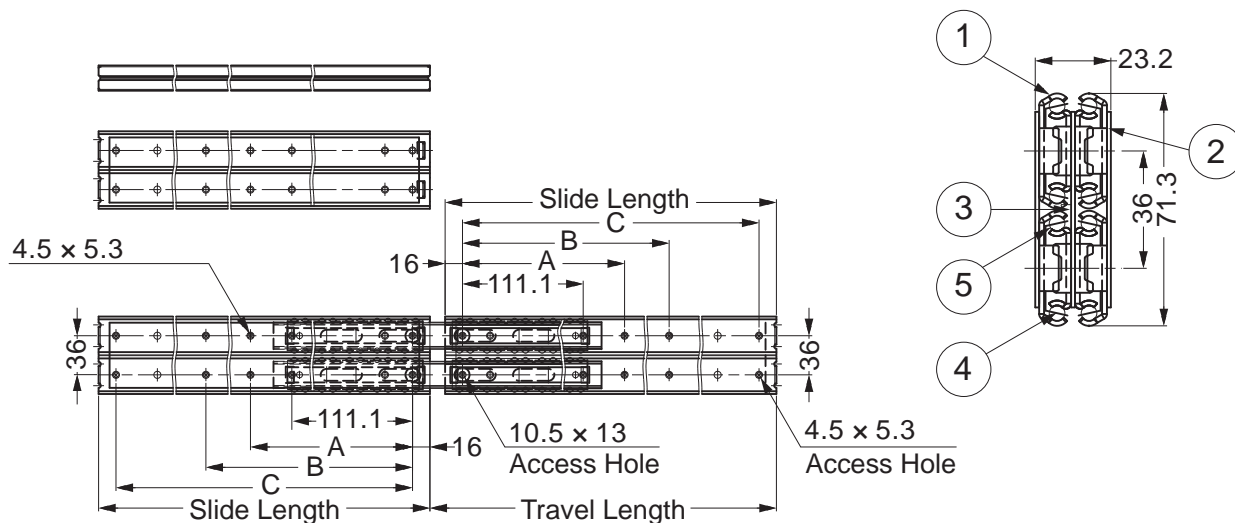

No.	Part Name	Material	Finish
①	Outer Rail	Stainless Steel (SUS304)	Satin
②	Inner Rail	Stainless Steel (SUS304)	Satin
③	Intermediate Member	Stainless Steel (SUS304)	Satin
④	Retainer	Stainless Steel (SUS304)	-
⑤	Balls	Stainless Steel (SUS304)	-

Item Code	Item Name	Slide Length	Travel Length	A	B	C	Load Capacity(pair)		Weight(pc)	Box
190-110-419	ESR10-12	305	319	-	149.2	273	2667N	272kgf	1.7kg	8pcs
190-110-420	ESR10-14	355.8	369.8	-	200	323.8	2628N	268kgf	1.9kg	8pcs
190-110-421	ESR10-16	406.6	420.6	-	250.8	374.6	2540N	259kgf	2.2kg	6pcs
190-110-422	ESR10-18	457.4	471.4	212.7	301.6	425.4	2452N	250kgf	2.5kg	6pcs
190-110-423	ESR10-20	508.2	522.2	238.1	352.4	476.2	2363N	241kgf	2.7kg	6pcs
190-110-424	ESR10-22	559	573	263.5	403.2	527	2246N	229kgf	3.0kg	6pcs
190-110-425	ESR10-24	609.8	623.8	288.9	454	577.8	2118N	216kgf	3.3kg	4pcs
190-110-426	ESR10-26	660.6	674.6	314.3	504.8	628.6	1961N	200kgf	3.6kg	4pcs
190-110-427	ESR10-28	711.4	725.4	339.7	555.6	679.4	1785N	182kgf	3.8kg	4pcs

# FULL EXTENSION SLIDE

LOAD CAPACITY  
64~116kgf

NO SCREW

STAINLESS  
304  
STEEL

5302

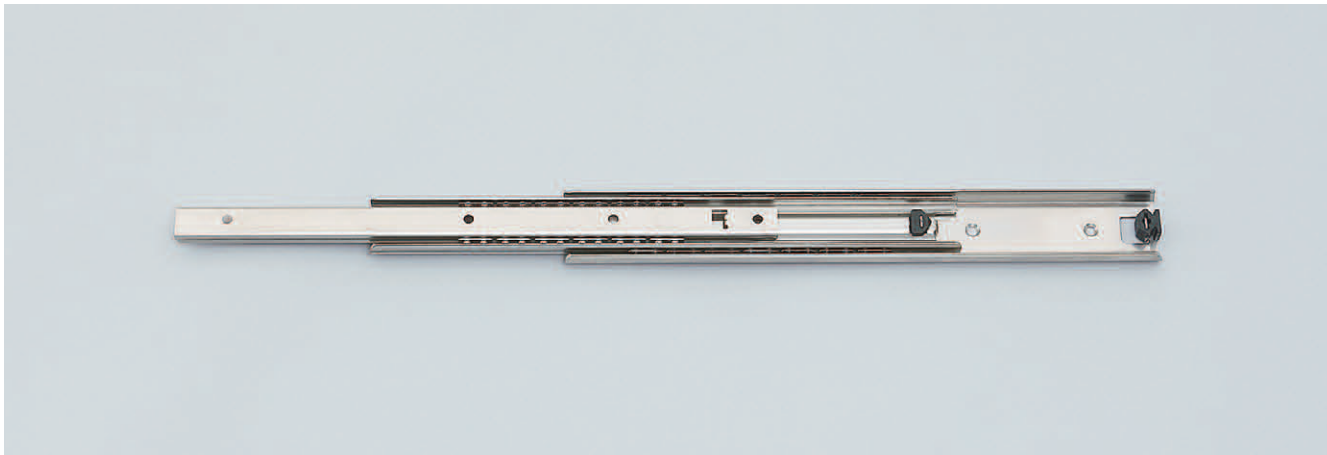

- Full extension.
- Positive stop.
- Non-handed.
- Hold-in detent.
- \* Mount with M6 Flat head screws.

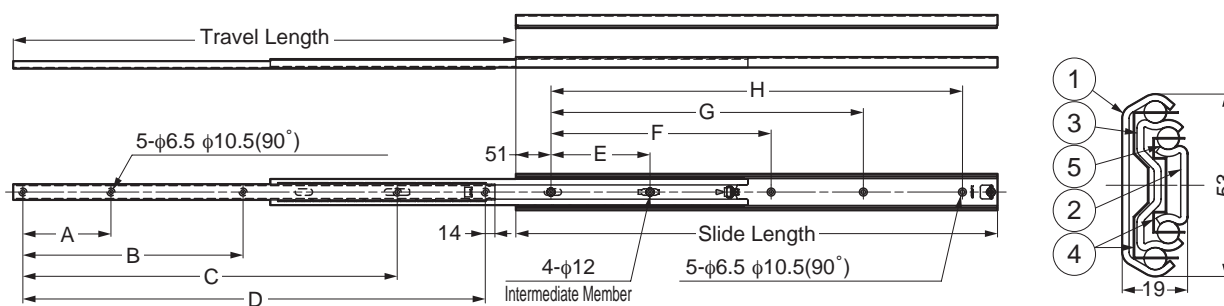

### ■ Bore Dimensions

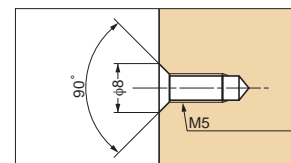

Same for outer & inner rail

No.	Part Name	Material	Finish/Color
①	Outer Rail	Stainless Steel (SUS304)	Plain
②	Inner Rail	Stainless Steel (SUS304)	Plain
③	Intermediate Member	Stainless Steel (SUS304)	Plain
④	Retainer	Stainless Steel (SUS304)	Plain
⑤	Balls	Stainless Steel (SUS304)	-

Item Code	Item Name	Slide Length	Travel Length	A	B	C	D	E	F	G	H	Load Capacity(pair)	Weight(pc)	Box	
190-112-730	5302S-300	300	334	128	256	-	-	112	192	-	-	1137N	116kgf	0.86kg	20pcs
190-112-731	5302S-350	350	384	160	320	-	-	144	240	-	-	1088N	111kgf	1kg	20pcs
190-112-732	5302S-400	400	433	160	256	352	-	144	224	304	-	970N	99kgf	1.14kg	16pcs
190-112-733	5302S-450	450	482	128	288	416	-	80	272	352	-	941N	96kgf	1.28kg	16pcs
190-112-734	5302S-500	500	532	128	288	448	-	112	272	384	-	902N	92kgf	1.43kg	10pcs
190-112-735	5302S-550	550	580	192	320	512	-	112	288	448	-	843N	86kgf	1.57kg	10pcs
190-112-736	5302S-600	600	630	208	336	544	-	112	336	496	-	794N	81kgf	1.71kg	10pcs
190-112-737	5302S-650	650	677	128	288	480	608	112	272	416	544	745N	76kgf	1.85kg	10pcs
190-112-738	5302S-700	700	728	128	336	544	672	144	304	448	592	696N	71kgf	2kg	8pcs
190-112-739	5302S-750	750	777	192	370	530	722	176	336	496	648	666N	68kgf	2.14kg	8pcs
190-112-740	5302S-800	800	826	224	388	548	772	192	384	576	688	627N	64kgf	2.28kg	8pcs

# FULL EXTENSION SLIDE

LOAD CAPACITY  
40~52kgf

NO SCREW

STAINLESS  
304  
STEEL

ESR-4513



- Full extension.
- Front disconnect.
- Positive stop.
- Hold-in detent.
- Non-handed.
- \* Sold in pairs.
- \* Mount with M4 or #8 Binding, Pan, or Truss head screws.

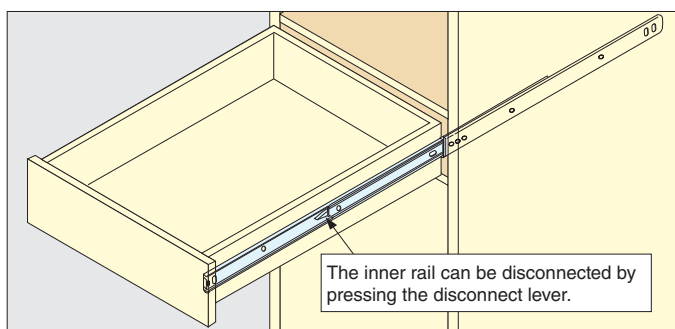
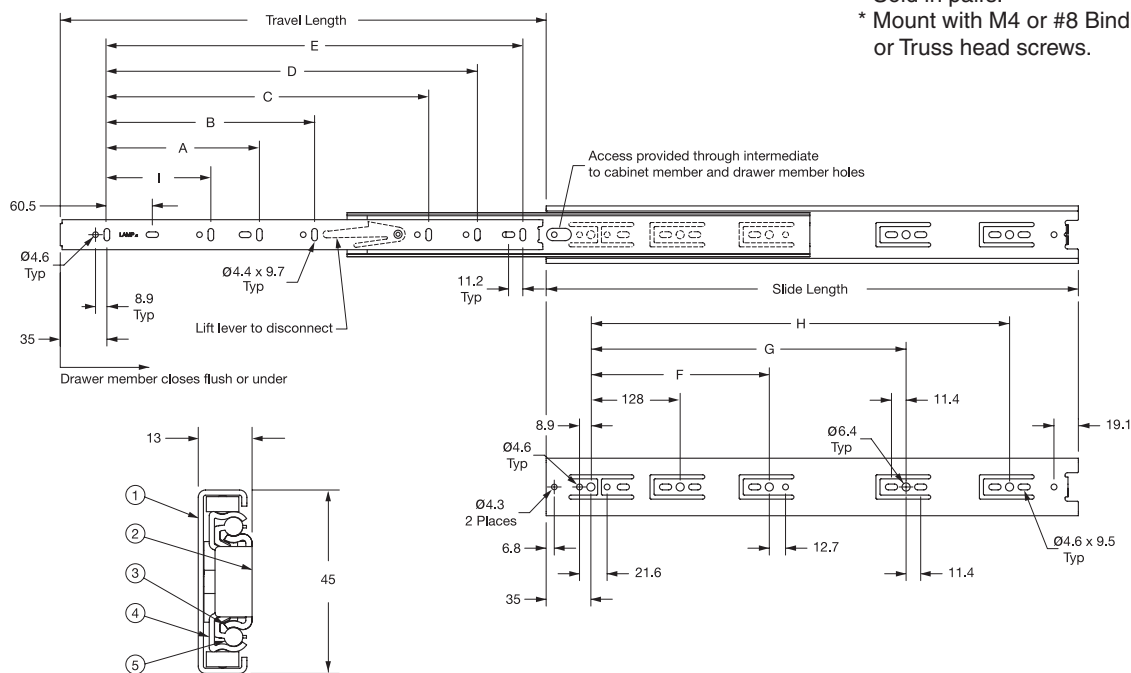

Installation

No.	Part Name	Material
①	Outer Rail	304 Stainless Steel
②	Inner Rail	
③	Retainer	
④	Intermediate Member	
⑤	Balls	

Item Code	Item Name	Slide Length	Travel Length	A	B	C	D	E	F	G	H	I	Load Rating (pair)	Weight (pair)	Box
190-118-867	ESR-4513-10	250	243					192	—			—	52kgf	0.74kg	10pair
190-118-868	ESR-4513-12	300	305					242					50kgf	0.93kg	10pair
190-118-869	ESR-4513-14	350	355					292					49kgf	1.07kg	10pair
190-118-870	ESR-4513-16	400	406	—				342					47kgf	1.22kg	10pair
190-118-871	ESR-4513-18	450	457		—			392					46kgf	1.37kg	10pair
190-118-872	ESR-4513-20	500	508			320		442	224	416		128	44kgf	1.53kg	10pair
190-118-873	ESR-4513-22	550	559				416	492			448		43kgf	1.68kg	10pair
190-118-874	ESR-4513-24	600	610				—	542			480		42kgf	1.83kg	10pair
190-118-875	ESR-4513-26	650	660	224		416		592					41kgf	1.98kg	10pair
190-118-876	ESR-4513-28	700	711		288		544	642			544		40kgf	2.14kg	10pair

FULL EXTENSION SLIDE

LOAD CAPACITY  
29-45kgf

NO SCREW

STAINLESS  
304  
STEEL

ESR-3813

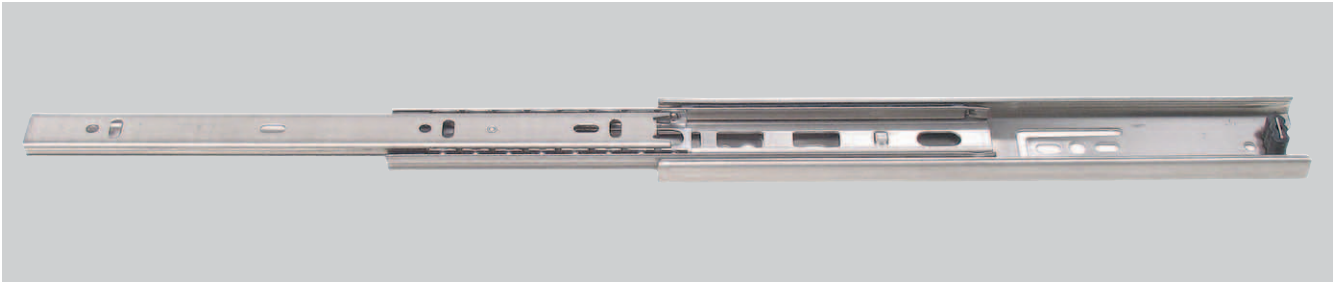

- Full extension.
- Front disconnect.
- Positive stop.
- Non-handed.
- Hold-in detent.
- \* Sold in pairs.
- \* Mount with M4 or #8 Binding, Pan, or Truss head screws.

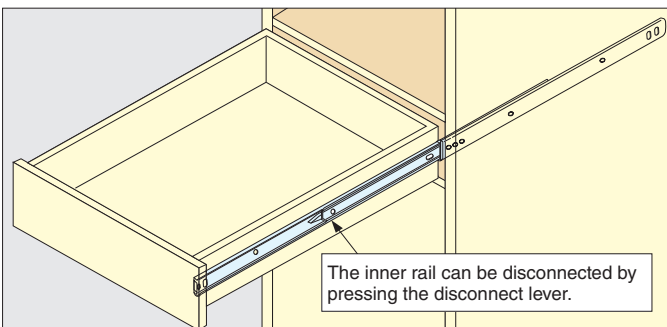
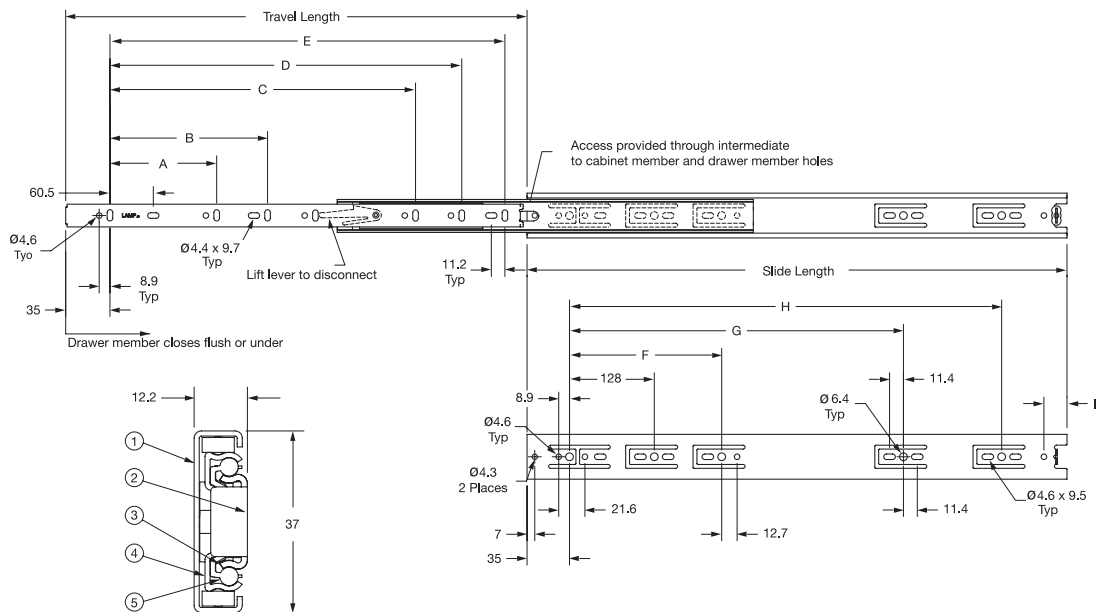

Installation

No.	Part Name	Material
①	Outer Rail	304 Stainless Steel
②	Inner Rail	
③	Retainer	
④	Intermediate Member	
⑤	Balls	

Item Code	Item Name	Slide Length	Travel Length	A	B	C	D	E	F	G	H	I	Load Rating (pair)	Weight (pair)	Box
190-118-877	ESR-3813-8	200	200	—	128	—	—	142	—	—	—	—	45kgf	0.40kg	10pair
190-118-878	ESR-3813-10	250	243	192				42kgf					0.53kg	10pair	
190-118-879	ESR-3813-12	300	305	242	128	—	—	242	224	—	—	19.1	42kgf	0.63kg	10pair
190-118-880	ESR-3813-14	350	355	292				38kgf					0.72kg	10pair	
190-118-881	ESR-3813-16	400	406	342	128	—	—	342	224	—	—	19.1	36kgf	0.81kg	10pair
190-118-882	ESR-3813-18	450	457	392				34kgf					0.91kg	10pair	
190-118-883	ESR-3813-20	500	508	442	128	320	—	442	224	—	—	19.1	33kgf	1kg	10pair
190-118-884	ESR-3813-22	550	559	416				31kgf					1.09kg	10pair	
190-118-885	ESR-3813-24	600	610	492	128	416	—	492	224	—	—	19.1	29kgf	1.18kg	10pair
				542				29kgf					1.18kg	10pair	

# FULL EXTENSION SLIDE



TSS3

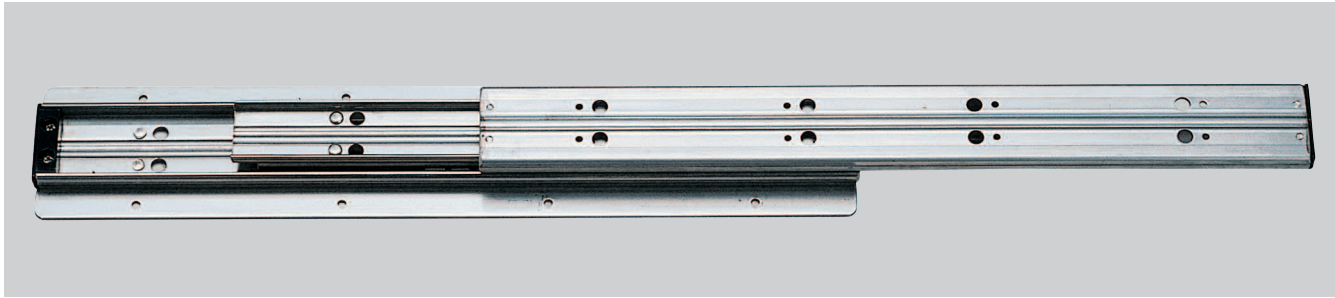

- Full extension.
- Positive stop.
- Non-handed.
- Heavy duty.

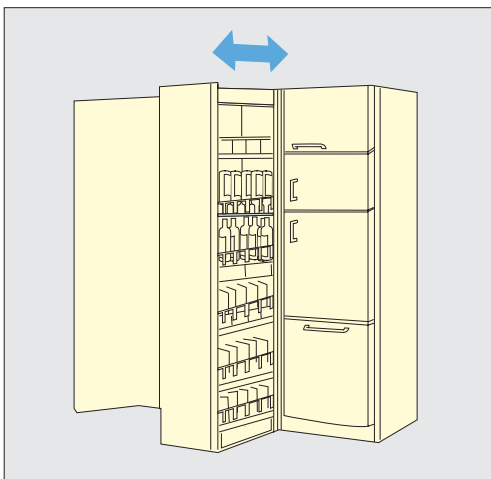
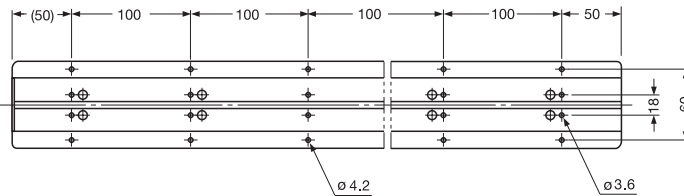
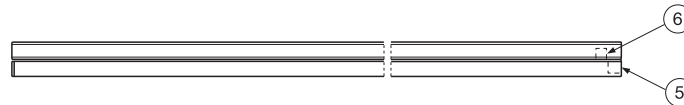
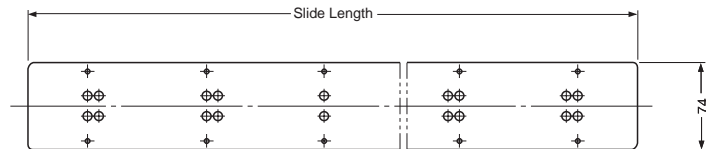
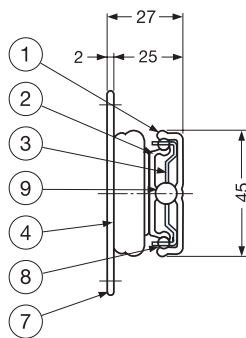
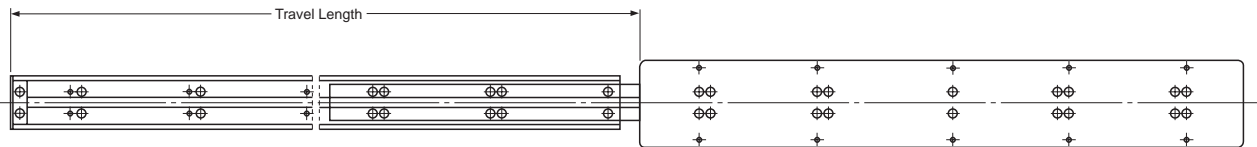

Installation

No.	Part Name	Material
①	Outer Rail	304 Stainless Steel
②	Inner Rail	
③	Retainer	Polyamide
④	End Stopper	
⑤	Outer Guide	Polyacetal
⑥	Inner Guide	
⑦	Plate	304 Stainless Steel
⑧	Large Balls	
⑨	Small Balls	Steel

Item Code	Item Name	Slide Length	Travel Length	Load Capacity (pair)	Weight (pc)	Box
190-110400	TSS3-300	300	336	95kgf	1.38kg	4pcs
190-110401	TSS3-400	400	436	90kgf	1.86kg	4pcs
190-110402	TSS3-500	500	536	85kgf	2.39kg	4pcs
190-110403	TSS3-600	600	636	80kgf	2.88kg	4pcs
190-110404	TSS3-800	800	836	65kgf	3.79kg	4pcs
190-110405	TSS3-1000	1000	1036	50kgf	4.71kg	4pcs



# FULL EXTENSION SLIDE



# ESR7



- Full extension.
- Front disconnect.
- Positive lock.
- Non-handed.
- \* Mount with M4 or #8 Binding, Pan, or Truss head screws.

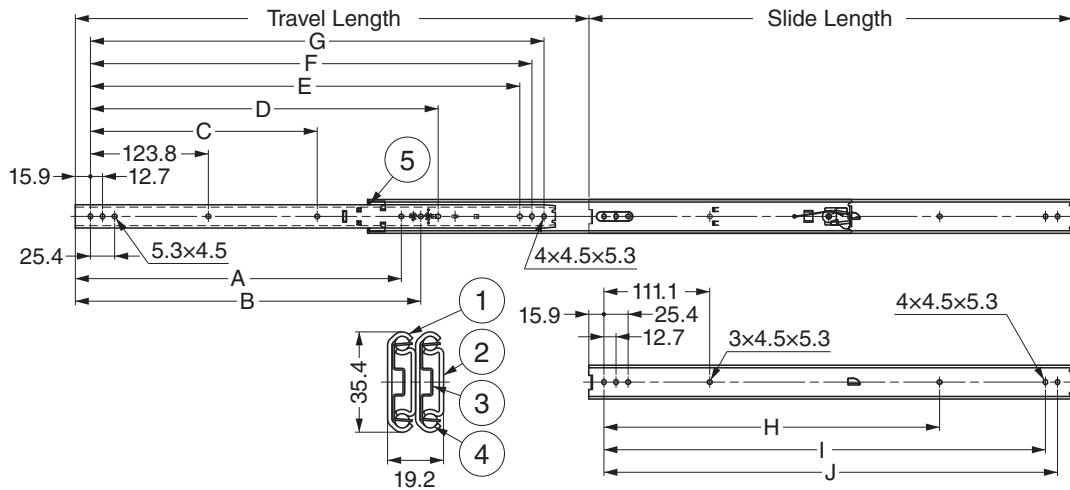

No.	Part Name	Material	Finish/Color
①	Outer Rail	Stainless Steel (SUS304)	Plain
②	Inner Rail	Stainless Steel (SUS304)	Plain
③	Retainer	Stainless Steel (SUS304)	Plain
④	Balls	Stainless Steel (SUS304)	-
⑤	Guide	Polyacetal	White

Item Code	Item Name	Slide Length	Travel Length	A	B	C	D	E	F	G	H	I	J	Load Capacity (pair)	Weight (pc)	Box	
190-111-318	ESR7-12	304.8	336	228	248.4	-	-	-	260.3	273	-	260.3	273	623N	63.5kgf	0.64kg	16pcs
190-111-319	ESR7-14	355.6	386.8	278.8	299.2	-	-	-	311.1	323.8	-	311.1	323.8	586N	59.8kgf	0.74kg	16pcs
190-111-320	ESR7-16	406.4	437.6	291.5	311.9	-	-	349.2	361.9	374.6	250.8	361.9	374.6	555N	56.6kgf	0.84kg	16pcs
190-111-321	ESR7-18	457.2	488.4	316.9	337.3	212.7	-	400	412.7	425.4	301.6	412.7	425.4	516N	52.6kgf	0.95kg	16pcs
190-111-322	ESR7-20	508	539.2	342.3	362.7	238.1	-	450.8	463.5	476.2	352.4	463.5	476.2	476N	48.5kgf	1.03kg	16pcs
190-111-323	ESR7-22	558.8	590	367.7	388.1	263.5	415.9	501.6	514.3	527	403.2	514.3	527	444N	45.3kgf	1.15kg	16pcs
190-111-324	ESR7-24	609.6	640.8	393.1	413.5	288.9	466.7	552.4	565.1	577.8	454	565.1	577.8	413N	42.1kgf	1.28kg	16pcs
190-111-325	ESR7-26	660.4	691.6	418.5	438.9	314.3	517.5	603.2	615.9	628.6	504.8	615.9	628.6	383N	39kgf	1.40kg	16pcs
190-111-326	ESR7-28	711.2	742.4	443.9	464.3	339.7	568.3	654	666.7	679.4	555.6	666.7	679.4	355N	36.2kgf	1.50kg	16pcs

FULL EXTENSION SLIDE



SNS35W

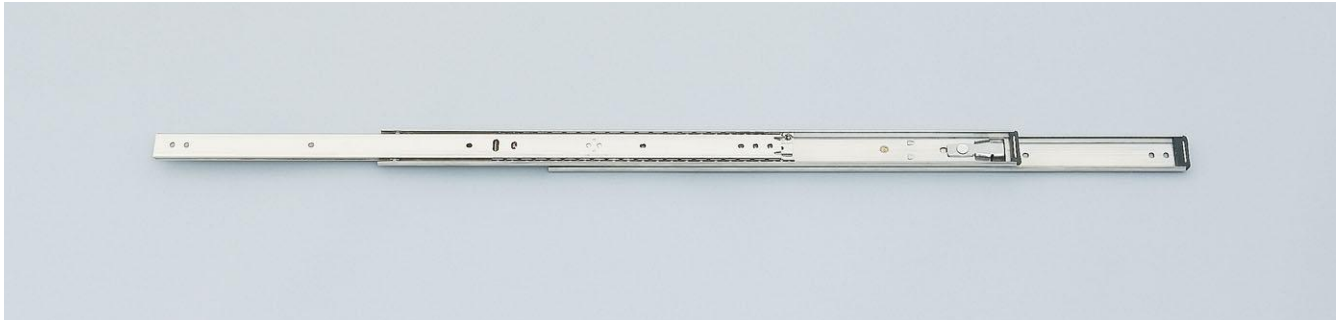

- Full extension.
- Front disconnect.
- Positive catch.
- Non-handed.

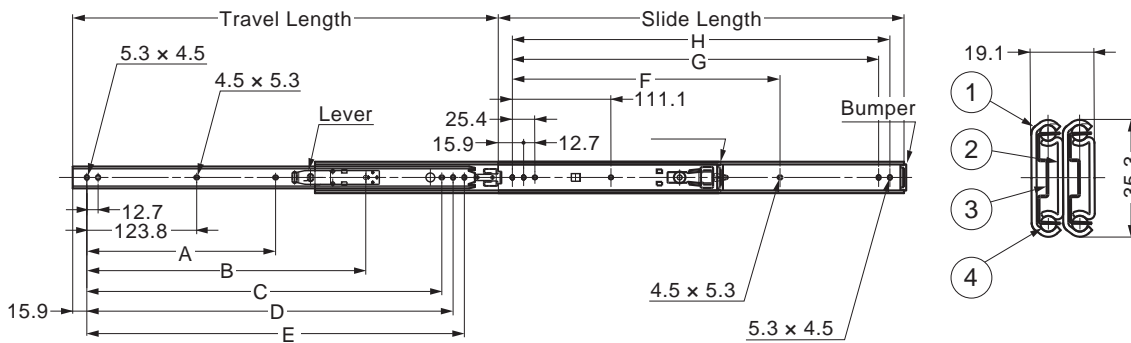

No.	Part Name	Material	Finish
①	Outer Rail	Stainless Steel (SUS304 B A)	Plain
②	Inner Rail	Stainless Steel (SUS304 B A)	Plain
③	Retainer	Stainless Steel (SUS304 B A)	Plain
④	Balls	Stainless Steel (SUS440C)	-

Item Code	Item Name	Slide Length	Travel Length	A	B	C	D	E	F	G	H	Load Capacity(pair)	Weight(pc)	Box	
190-112-231	SNS35W-30	304.8	327.2	-	-	-	260.3	273	-	260.3	273	623N	62kgf	0.78kg	20pcs
190-112-232	SNS35W-35	355.6	377.9	-	-	298.4	311.1	323.8	-	311.1	323.8	586N	59kgf	0.903kg	20pcs
190-112-233	SNS35W-40	406.4	428.7	-	-	349.2	361.9	374.6	250.8	361.9	374.6	555N	56kgf	1.028kg	20pcs
190-112-234	SNS35W-45	457.2	479.5	212.7	-	400	412.7	425.4	301.6	412.7	425.4	516N	52kgf	1.151kg	20pcs
190-112-235	SNS35W-50	508	530.3	238.1	365.1	450.8	463.5	476.2	352.4	463.5	476.2	475N	48kgf	1.275kg	20pcs
190-112-236	SNS35W-55	558.8	581.2	263.5	415.9	501.6	514.3	527	403.2	514.3	527	444N	44kgf	1.399kg	20pcs
190-112-237	SNS35W-60	609.6	631.9	288.9	466.7	552.4	565.1	577.8	454	565.1	577.8	413N	41kgf	1.523kg	20pcs
190-112-238	SNS35W-65	660.4	682.7	314.3	517.5	603.2	615.1	628.6	504.8	615.9	628.6	382N	38kgf	1.647kg	20pcs
190-112-239	SNS35W-70	711.2	733.5	339.7	568.3	654	666.7	679.4	555.6	666.7	679.4	355N	36kgf	1.77kg	20pcs

FULL EXTENSION SLIDE



SNS35D



- Full extension.
- Positive stop.
- Non-handed.

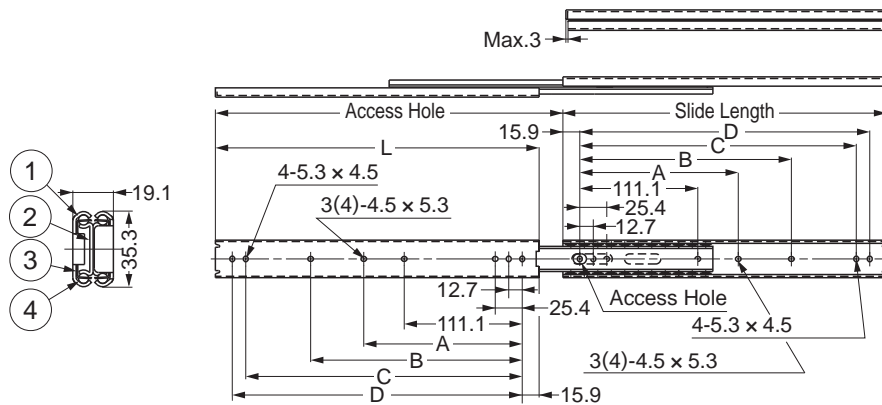

No.	Part Name	Material	Finish
①	Outer Rail	Stainless Steel (SUS304 BA)	Plain
②	Inner Rail	Stainless Steel (SUS304 BA)	Plain
③	Retainer	Stainless Steel (SUS304 BA)	Plain
④	Balls	Stainless Steel (SUS440C)	—

Item Code	Item Name	Slide Length	Travel Length	A	B	C	D	Load Capacity(pair)	Weight(pc)	Box
190-110-200	SNS35D-30	304.8	327.2	—	149.2	260.3	273	588N 60kgf	0.62kg	20pcs
190-110-201	SNS35D-35	355.6	377.9	—	200	311.1	323.8	579N 59kgf	0.72kg	20pcs
190-110-202	SNS35D-40	406.4	428.7	—	250.8	361.9	374.6	559N 57kgf	0.82kg	20pcs
190-110-203	SNS35D-45	457.2	479.5	212.7	301.6	412.7	425.4	549N 56kgf	0.92kg	20pcs
190-110-204	SNS35D-50	508	530.3	238.1	352.4	463.5	476.2	530N 54kgf	1.025kg	20pcs
190-110-205	SNS35D-55	558.8	580.3	263.5	403.2	514.3	527	500N 51kgf	1.125kg	20pcs
190-110-206	SNS35D-60	609.6	631.9	288.9	454	565.1	577.8	481N 49kgf	1.225kg	20pcs
190-110-207	SNS35D-65	660.4	682.7	314.3	504.8	615.9	628.6	461N 47kgf	1.325kg	20pcs
190-110-208	SNS35D-70	711.2	733.5	339.7	555.6	666.7	679.4	441N 45kgf	1.425kg	20pcs

# FULL EXTENSION SLIDE



# SNS27D



- Full extension.
- Positive stop.
- Non-handed.

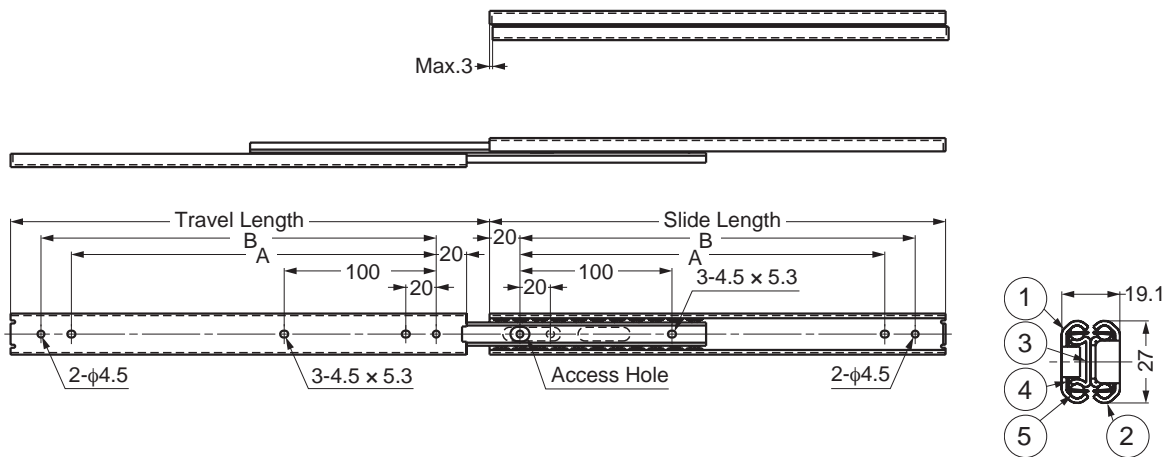

No.	Part Name	Material	Finish
①	Outer Rail	Stainless Steel (SUS304BA)	Plain
②	Inner Rail	Stainless Steel (SUS304BA)	Plain
③	Intermediate Member	Stainless Steel (SUS304BA)	Plain
④	Retainer	Stainless Steel (SUS304BA)	Plain
⑤	Balls	Stainless Steel (SUS440C)	-

Item Code	Item Name	Slide Length	Travel Length	A	B	Load Capacity(pair)		Weight(pc)	Box
190-110-184	SNS27D-20	200	216.8	140	160	373N	38kgf	0.335kg	30pcs
190-110-185	SNS27D-25	250	266	190	210	363N	37kgf	0.415kg	30pcs
190-110-186	SNS27D-30	300	315.2	240	260	353N	36kgf	0.55kg	30pcs
190-110-187	SNS27D-35	350	364.4	290	310	333N	34kgf	0.58kg	30pcs
190-110-188	SNS27D-40	400	413.6	340	360	314N	32kgf	0.66kg	30pcs
190-110-189	SNS27D-45	450	462.8	390	410	294N	30kgf	0.74kg	30pcs
190-110-190	SNS27D-50	500	512	440	460	275N	28kgf	0.821kg	30pcs

# FULL EXTENSION SLIDE

LOAD CAPACITY  
12-18kgf

NO SCREW

STAINLESS  
304  
STEEL

## 273SL

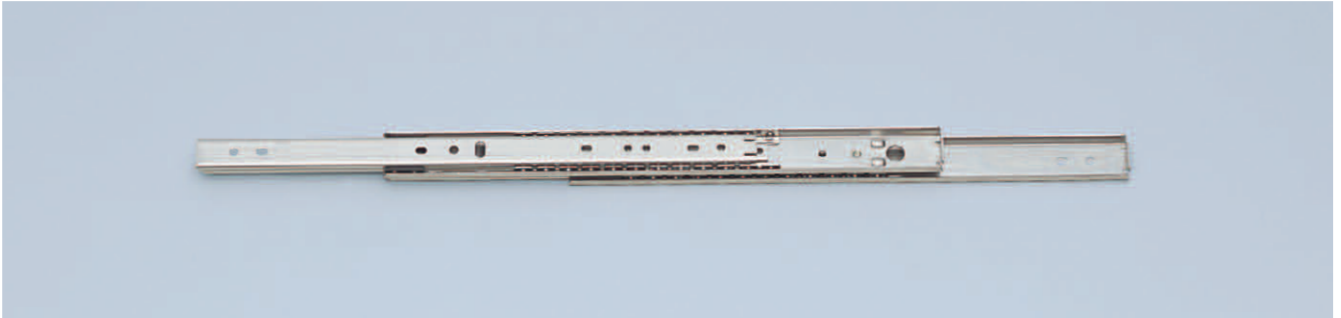

- Full extension.
- Front disconnect.
- Positive stop.
- Non-handed.
- \* Mount with M4 or #8 Binding, Pan, or Truss head screws.

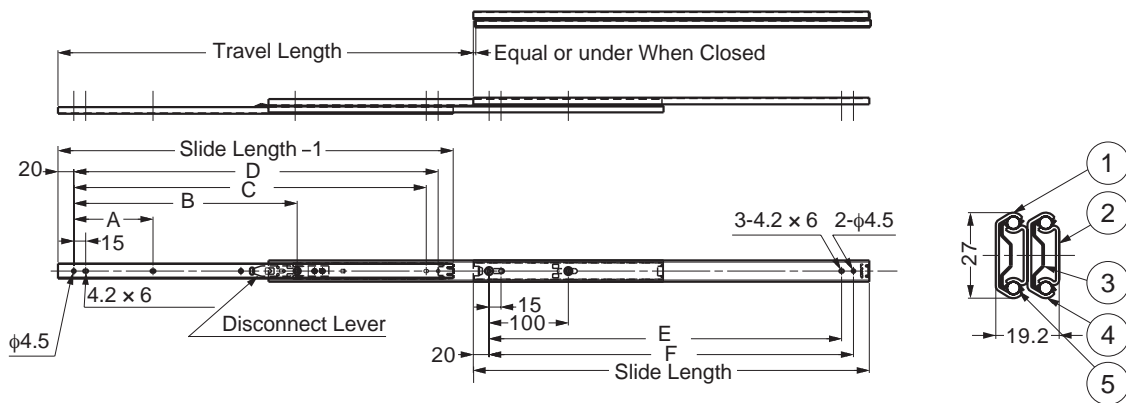

No.	Part Name	Material	Finish
①	Outer Rail	Stainless Steel (SUS304BA)	Plain
②	Inner Rail	Stainless Steel (SUS304BA)	Plain
③	Retainer	Stainless Steel (SUS304BA)	Plain
④	Intermediate Member	Stainless Steel (SUS304BA)	Plain
⑤	Balls	Stainless Steel (SUS420)	-

Item Code	Item Name	Slide Length	Travel Length	A	B	C	D	E	F	Load Capacity (pair)		Weight (pair)	Box
190-116-712	273SL-200	200	221	-	135	-	-	145	160	177N	18kgf	0.55kg	10pair
190-116-713	273SL-250	250	280	-	143.5	195	210	195	210	167N	17kgf	0.68kg	10pair
190-116-714	273SL-300	300	327	100	188	245	260	245	260	157N	16kgf	0.82kg	10pair
190-116-715	273SL-350	350	376	100	211.5	295	310	295	310	147N	15kgf	0.96kg	10pair
190-116-716	273SL-400	400	426	100	236	345	360	345	360	137N	14kgf	1.09kg	10pair
190-116-717	273SL-450	450	478	100	261.5	395	410	395	410	128N	13kgf	1.24kg	10pair
190-116-718	273SL-500	500	524	100	282	445	460	445	460	118N	12kgf	1.35kg	10pair

# FULL EXTENSION SLIDE

LOAD CAPACITY  
13~17kgf

NO SCREW

STAINLESS  
304  
STEEL

ESR2031



- Full extension.
- Positive stop.
- Non-handed.
- Requires #4 or M3 pan head screw.

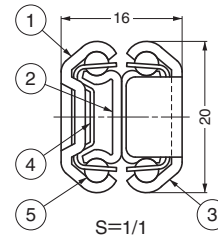
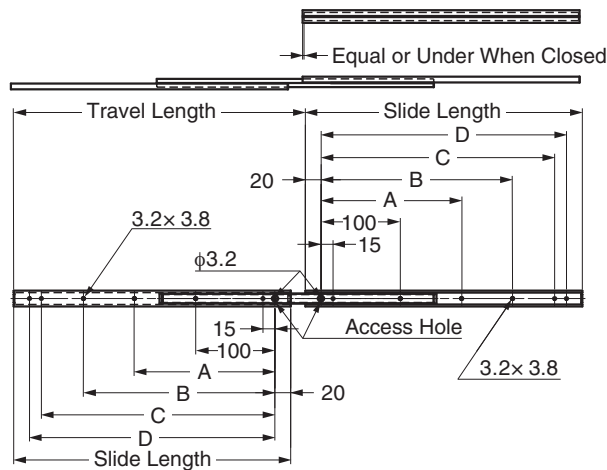

※ Depending on production lot, aspects of the end stop might be slightly different as shown on the drawings.

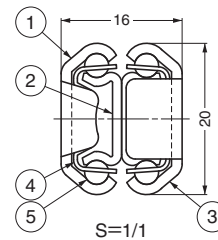

No.	Part Name	Material	Finish
①	Outer Rail	Stainless Steel (SUS304)	Plain
②	Intermediate Member	Stainless Steel (SUS304)	Plain
③	Inner Rail	Stainless Steel (SUS304)	Plain
④	Retainer	Stainless Steel (SUS304)	Plain
⑤	Balls	Stainless Steel (SUS304)	—

Item Code	Item Name	Slide Length	Travel Length	A	B	C	D	Load Capacity(pair)		Weight(pc)	Box
190-011-656	ESR2031-200	200	229	—	—	145	160	167N	17kgf	0.2kg	96pcs
190-011-657	ESR2031-250	250	269	—	—	195	210	167N	17kgf	0.25kg	48pcs
190-011-658	ESR2031-300	300	329	—	160	245	260	167N	17kgf	0.3kg	48pcs
190-011-659	ESR2031-350	350	369	—	210	295	310	167N	17kgf	0.35kg	48pcs
190-011-660	ESR2031-400	400	429	—	260	345	360	167N	17kgf	0.4kg	48pcs
190-011-661	ESR2031-450	450	469	205	310	395	410	157N	16kgf	0.45kg	48pcs
190-011-662	ESR2031-500	500	529	230	360	445	460	127N	13kgf	0.5kg	48pcs

# FULL EXTENSION SLIDE

LOAD CAPACITY  
43~65kgf

NO SCREW

STAINLESS  
304  
STEEL

## ESR3

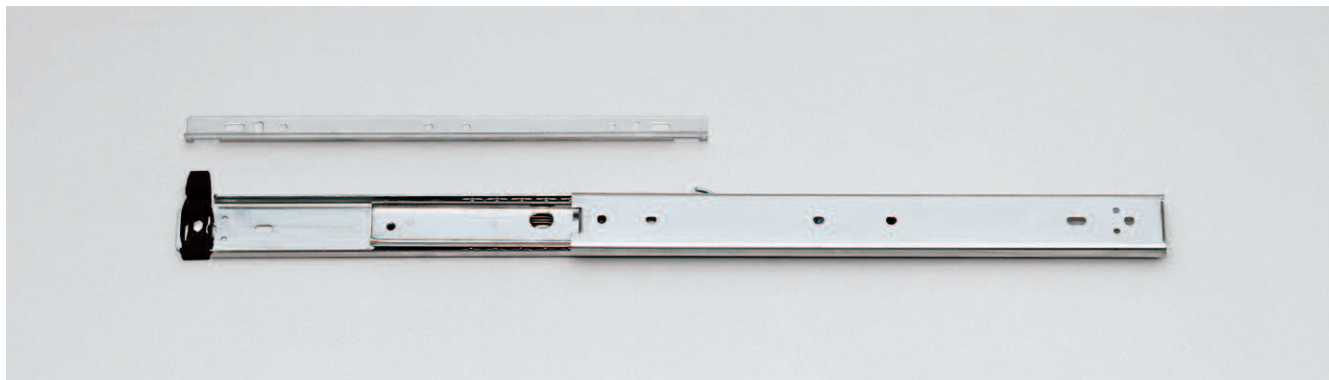

- Handed.
- Full extension.
- Quick disconnect.
- Positive stop.
- \* Sold in pairs.
- \* Mount with M4 or #8 Binding, Pan, or Truss head screws.

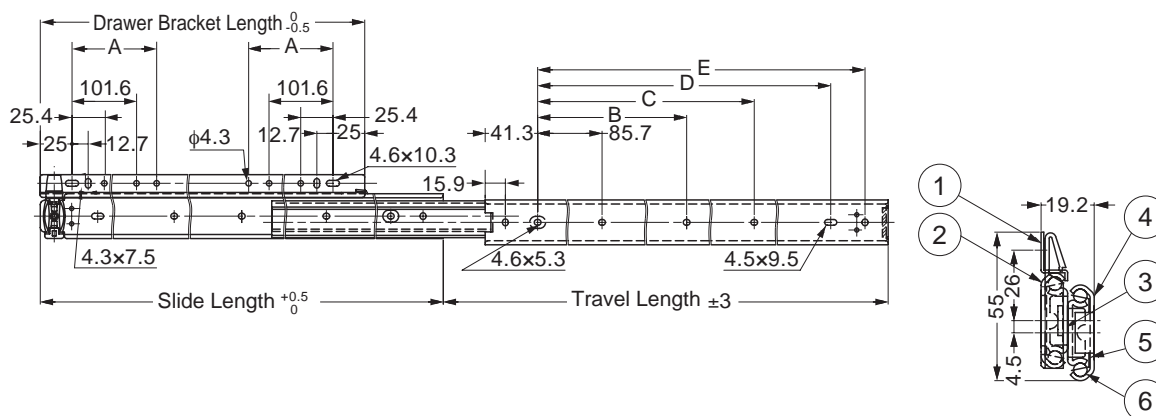

No.	Part Name	Material	Finish
①	Drawer Bracket	Stainless Steel (SUS304)	Plain
②	Inner Rail	Stainless Steel (SUS304)	Plain
③	Intermediate Member	Stainless Steel (SUS304)	Plain
④	Outer Rail	Stainless Steel (SUS304)	Plain
⑤	Retainer	Stainless Steel (SUS304)	Plain
⑥	Balls	Stainless Steel (SUS304)	—

Item Code	Item Name	Slide Length	Travel Length	Drawer Bracket Length	A	B	C	D	E	Load Capacity (pair)	Weight (pair)	Box	
190-115-206	ESR3-12	304.8	348.4	273	—	—	123.1	218.3	245.3	637N	65kgf	0.68kg	6pair
190-115-207	ESR3-14	355.6	399.2	273	—	—	173.9	269.1	296.1	598N	61kgf	0.78kg	6pair
190-115-208	ESR3-16	406.4	450	375	—	—	224.7	319.9	346.9	598N	61kgf	0.91kg	6pair
190-110-413	ESR3-18	457.2	500.8	375	—	187.3	275.5	370.7	397.7	549N	56kgf	1.01kg	6pair
190-115-210	ESR3-20	508	551.6	375	—	212.7	326.3	421.5	448.5	510N	52kgf	1.11kg	6pair
190-115-211	ESR3-22	558.8	602.4	527	177.8	238.1	377.1	472.3	499.3	510N	52kgf	1.26kg	6pair
190-115-212	ESR3-24	609.6	653.2	527	177.8	263.5	427.9	523.1	550.1	471N	48kgf	1.37kg	6pair
190-110-417	ESR3-26	660.4	704	575.3	177.8	288.9	478.7	573.9	600.9	422N	43kgf	1.48kg	6pair
190-115-214	ESR3-28	711.2	754.8	575.3	177.8	314.3	529.5	624.7	651.7	422N	43kgf	1.58kg	6pair

# 3/4 EXTENSION SLIDE



**ESR5**

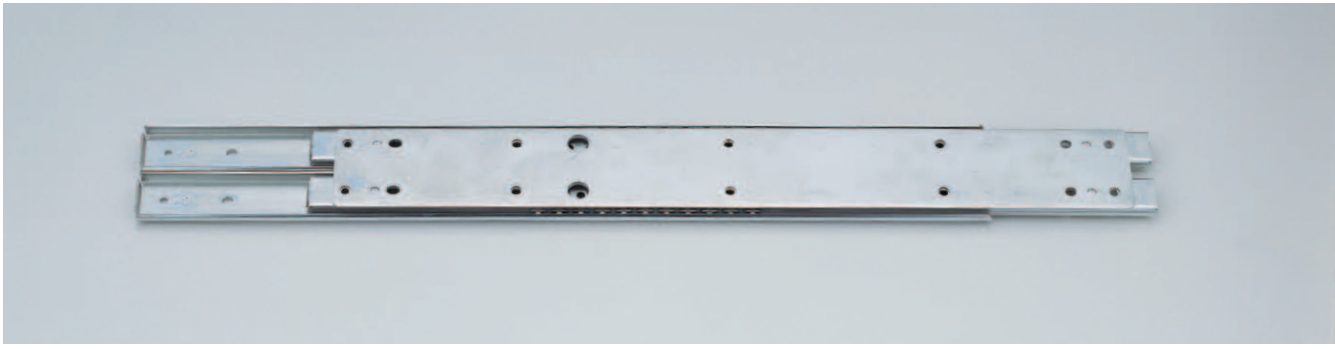

- 3/4 extension.
- Positive stop.
- Non-handed.
- Heavy duty.
- \* Mount with M4 or #8 Binding, Pan, or Truss head screws.

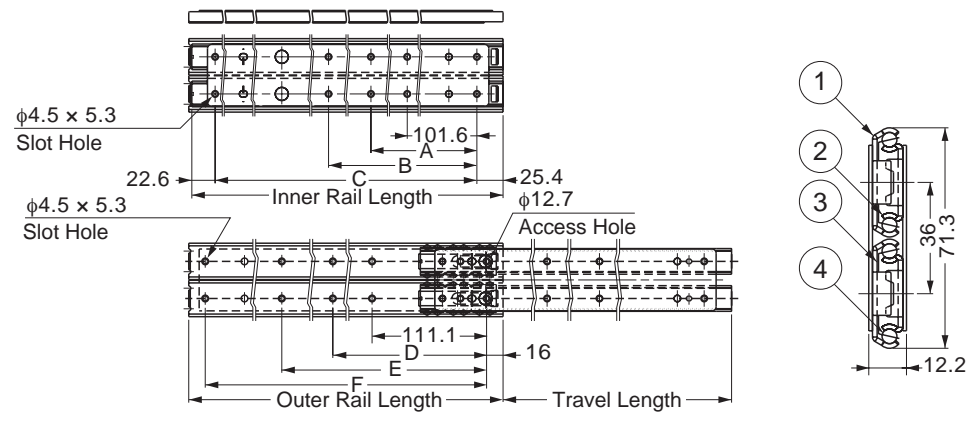

No.	Part Name	Material	Finish
①	Outer Rail	Stainless Steel (SUS304)	Satin
②	Inner Rail	Stainless Steel (SUS304)	Satin
③	Retainer	Stainless Steel (SUS304)	—
④	Balls	Stainless Steel (SUS304)	—

Item Code	Item Name	Slide Length	Travel Length	A	B	C	D	E	F	Load Capacity(pair)		Weight(pc)	BOX
190-110-428	ESR5-12	305	221.8	—	152.4	254	—	149.2	273	1118N	114kgf	0.9kg	12pcs
190-110-429	ESR5-14	355.8	259.9	—	203.2	304.8	—	200	323.8	1069N	109kgf	1.0kg	12pcs
190-110-430	ESR5-16	406.6	298	—	254	355.6	—	250.8	374.6	1020N	104kgf	1.2kg	12pcs
190-110-431	ESR5-18	457.4	348.8	203.2	304.8	406.4	212.7	301.6	425.4	1000N	102kgf	1.3kg	12pcs
190-110-432	ESR5-20	508.2	361.5	228.6	355.6	457.2	238.1	352.4	476.2	971N	99kgf	1.5kg	12pcs
190-110-433	ESR5-22	559	425	254	406.4	508	263.5	403.2	527	922N	94kgf	1.6kg	12pcs
190-110-434	ESR5-24	609.8	450.4	279.4	457.2	558.8	288.9	454	577.8	873N	89kgf	1.8kg	12pcs
190-110-435	ESR5-26	660.6	463.1	304.8	508	609.6	314.3	504.8	628.6	843N	86kgf	1.9kg	12pcs
190-110-436	ESR5-28	711.4	501.2	330.2	558.8	660.4	339.7	555.6	679.4	785N	80kgf	2.0kg	12pcs



# 3/4 EXTENSION SLIDE



ESR1



- 3/4 extension.
- Front disconnect.
- Friction brake stop.
- Non-handed.
- \* Mount with M4 or #8 Binding, Pan, or Truss head screws.

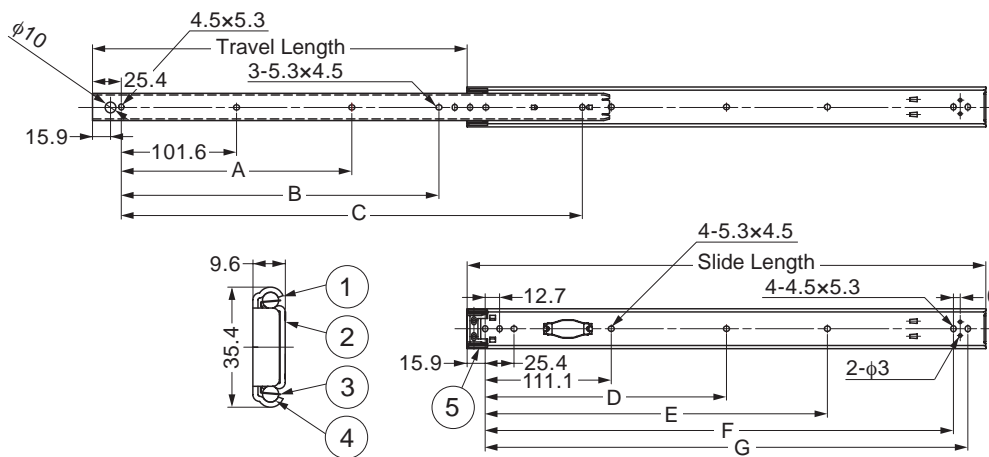

No.	Part Name	Material	Finish/Color
①	Outer Rail	Stainless Steel (SUS304)	Plain
②	Inner Rail	Stainless Steel (SUS304)	Plain
③	Retainer	Stainless Steel (SUS304)	Plain
④	Balls	Stainless Steel (SUS304)	—
⑤	Guide	Polyacetal	White

Item Code	Item Name	Slide Length	Travel Length	A	B	C	D	E	F	G	Load Capacity(pair)	Weight(pc)	Box	
190-111-301	ESR1-12	304.8	228.6	—	152.4	254	—	149.2	260.3	273	481N	49kgf	0.30kg	30pcs
190-111-302	ESR1-14	355.6	279.4	—	203.2	304.8	—	200	311.1	323.8	461N	47kgf	0.36kg	30pcs
190-111-303	ESR1-16	406.4	304.8	—	254	355.6	—	250.8	361.9	374.6	422N	43kgf	0.42kg	30pcs
190-111-304	ESR1-18	457.2	330.2	203.2	304.8	406.4	212.7	301.6	412.7	425.4	402N	41kgf	0.46kg	30pcs
190-111-305	ESR1-20	508	381	228.6	355.6	457.2	238.1	352.4	463.5	476.2	363N	37kgf	0.49kg	30pcs
190-111-306	ESR1-22	558.8	406.4	254	406.4	508	263.5	403.2	514.3	527	333N	34kgf	0.56kg	30pcs
190-111-307	ESR1-24	609.6	432.8	279.4	457.2	558.8	288.9	454	565.1	577.8	294N	30kgf	0.59kg	30pcs
190-111-308	ESR1-26	660.4	482.6	304.8	508	609.6	314.3	504.8	615.9	628.6	265N	27kgf	0.66kg	30pcs
190-111-309	ESR1-28	711.2	508	330.2	558.8	660.4	339.7	555.6	666.7	679.4	245N	25kgf	0.69kg	30pcs

# 3/4 EXTENSION SLIDE



# SNS35S

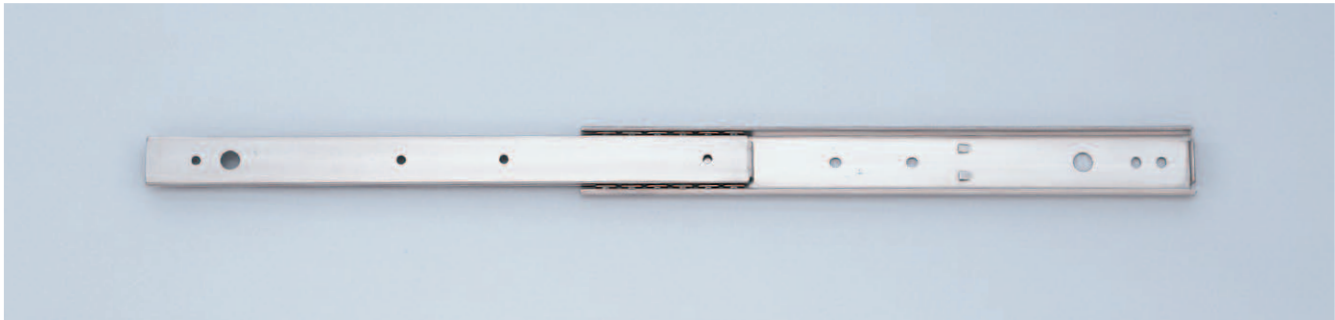

- 3/4 extension.
- All Stainless Steel.

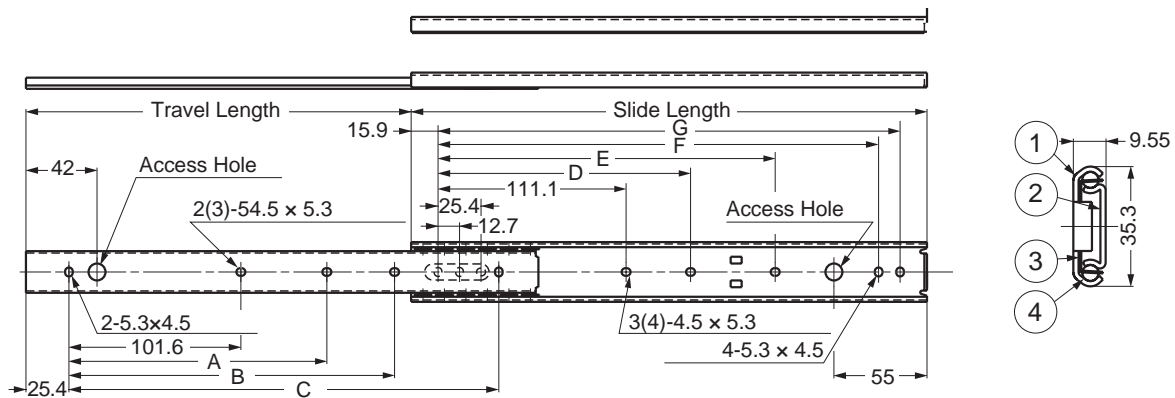

No.	Part Name	Material	Finish
①	Outer Rail	Stainless Steel(SUS304BA)	Plain
②	Inner Rail	Stainless Steel(SUS304BA)	Plain
③	Retainer	Stainless Steel(SUS304BA)	Plain
④	Balls	Stainless Steel(SUS440C)	—

Item Code	Item Name	Slide Length	Travel Length	A	B	C	D	E	F	G	Load Capacity(pair)	Weight(pc)	Box	
190-110-191	SNS35S-30	304.8	228.6	—	152.4	254	—	149.2	260.3	273	481N	49kgf	0.31kg	40pcs
190-110-192	SNS35S-35	355.6	279.4	—	203.2	304.8	—	200	311.1	323.8	461N	47kgf	0.36kg	40pcs
190-110-193	SNS35S-40	406.4	304.8	—	254	355.6	—	250.8	361.9	374.6	422N	43kgf	0.41kg	40pcs
190-110-194	SNS35S-45	457.2	330.2	203.2	304.8	406.4	212.7	301.6	412.7	425.4	402N	41kgf	0.46kg	40pcs
190-110-195	SNS35S-50	508	381	228.6	355.6	457.2	238.1	352.4	463.5	476.2	363N	37kgf	0.51kg	40pcs
190-110-196	SNS35S-55	558.8	406.4	254	406.4	508	263.5	403.2	514.3	527	333N	34kgf	0.56kg	40pcs
190-110-197	SNS35S-60	609.6	431.8	279.4	457.2	558.8	288.9	454	565.1	577.8	294N	30kgf	0.61kg	40pcs
190-110-198	SNS35S-65	660.4	482.6	304.8	508	609.6	314.3	504.8	615.9	628.6	265N	27kgf	0.66kg	40pcs
190-110-199	SNS35S-70	711.2	508	330.2	558.8	660.4	339.7	555.6	666.7	679.4	245N	25kgf	0.71kg	40pcs

# 3/4 EXTENSION SLIDE



# SNS27S

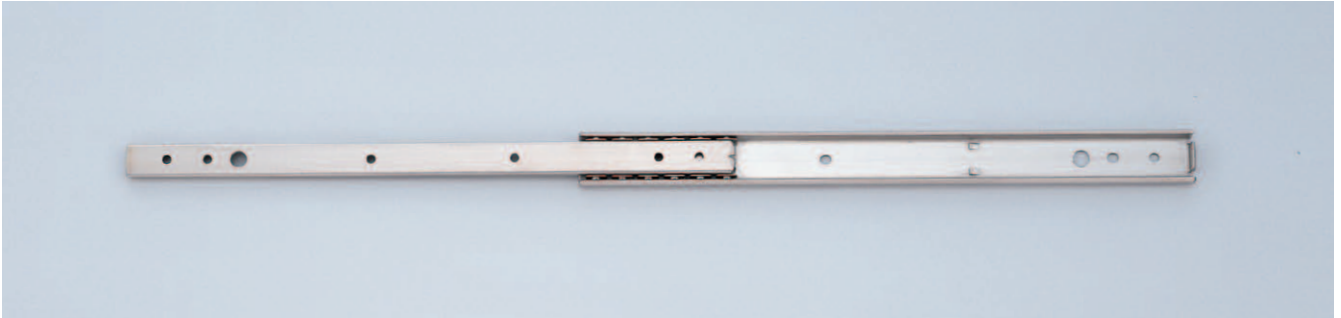

- 3/4 extension.
- All stainless steel slide.
- Positive stop.
- Non handed.

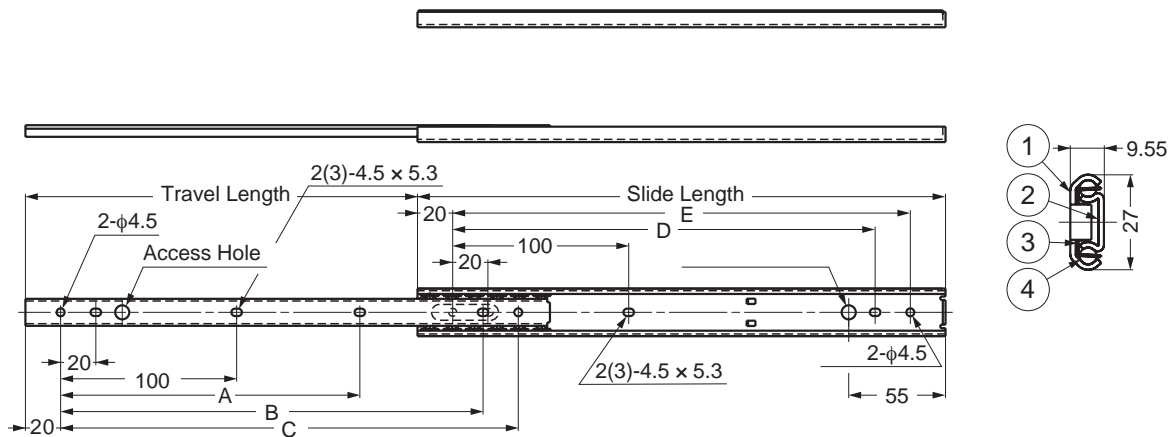

No.	Part Name	Material	Finish
①	Outer Rail	Stainless Steel(SUS304BA)	Plain
②	Inner Rail	Stainless Steel(SUS304BA)	Plain
③	Retainer	Stainless Steel(SUS304BA)	Plain
④	Balls	Stainless Steel(SUS440C)	—

Item Code	Item Name	Slide Length	Travel Length	A	B	C	D	E	Load Capacity(pair)	Weight(pc)	Box	
190-110-177	SNS27S-20	200	135	—	140	160	140	160	255N	26kgf	0.17kg	40pcs
190-110-178	SNS27S-25	250	185	150	190	210	190	210	235N	24kgf	0.21kg	40pcs
190-110-179	SNS27S-30	300	222	190	240	260	240	260	235N	24kgf	0.25kg	40pcs
190-110-180	SNS27S-35	350	260	225	290	310	290	310	226N	23kgf	0.29kg	40pcs
190-110-181	SNS27S-40	400	297	265	340	360	340	360	206N	21kgf	0.33kg	40pcs
190-110-182	SNS27S-45	450	334	300	390	410	390	410	196N	20kgf	0.37kg	40pcs
190-110-183	SNS27S-50	500	371	337	440	460	440	460	177N	18kgf	0.41kg	40pcs

# 3/4 EXTENSION SLIDE

LOAD CAPACITY  
14-18 kgf

NO SCREW

STAINLESS  
304  
STEEL

## 272SL



- 3/4 extension.
- Front disconnect.
- Positive stop.
- Non-handed.
- \* Mount with M4 or #8 Binding, Pan, or Truss head screws.

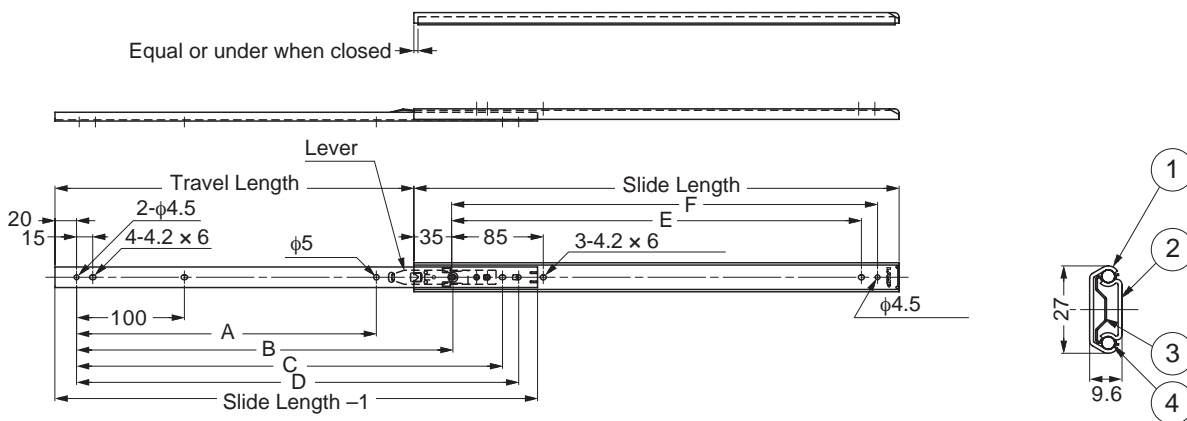

No.	Part Name	Material	Finish
①	Outer Rail	Stainless Steel (SUS304)	Plain
②	Inner Rail	Stainless Steel (SUS304)	Plain
③	Retainer	Stainless Steel (SUS304)	Plain
④	Balls	Stainless Steel (SUS420)	—

Item Code	Item Name	Slide Length	Travel Length	A	B	C	D	E	F	Load Capacity(pair)	Weight(pair)	Box	
190-116-707	272SL-300	300	220	165	236	—	—	230	245	177N	18kgf	0.42kg	20pair
190-116-708	272SL-350	350	261	206	277	—	—	280	295	167N	17kgf	0.49kg	20pair
190-116-709	272SL-400	400	301	246	317	—	362.5	330	345	157N	16kgf	0.56kg	20pair
190-116-710	272SL-450	450	333	278	349	395	410	380	395	147N	15kgf	0.62kg	20pair
190-116-711	272SL-500	500	373	318	389	445	460	430	445	137N	14kgf	0.68kg	20pair

# 3/4 EXTENSION SLIDE

LOAD CAPACITY  
11-16 kgf

NO SCREW

STAINLESS  
304  
STEEL

## ESR2021



- 3/4 extension.
- Positive stop.
- Non-handed.
- Requires #4 or M3 pan head screw.

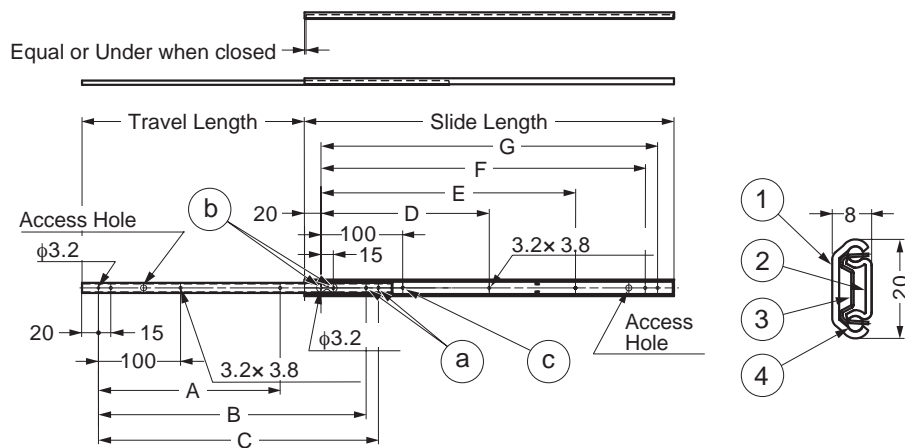

No.	Part Name	Material	Finish
①	Outer Rail	Stainless Steel (SUS304)	Plain
②	Inner Rail	Stainless Steel (SUS304)	Plain
③	Retainer	Stainless Steel (SUS304)	Plain
④	Balls	Stainless Steel (SUS304)	—

Item Code	Item Name	Slide Length	Travel Length	A	B	C	D	E	F	G	Load Capacity(pair)	Weight(pc)	Box
190-011-649	ESR2021-200	200	134	—	145	160	—	—	145	160	127N 13kgf	0.10kg	200pcs
190-011-650	ESR2021-250	250	184	150	195	210	—	—	195	210	147N 15kgf	0.13kg	100pcs
190-011-651	ESR2021-300	300	224	190	245	260	—	160	245	260	157N 16kgf	0.15kg	100pcs
190-011-652	ESR2021-350	350	244	225	295	310	—	210	295	310	157N 16kgf	0.18kg	100pcs
190-011-653	ESR2021-400	400	294	265	345	360	—	260	345	360	147N 15kgf	0.20kg	100pcs
190-011-654	ESR2021-450	450	334	300	395	410	205	310	395	410	127N 13kgf	0.23kg	100pcs
190-011-655	ESR2021-500	500	384	337	445	460	230	360	445	460	108N 11kgf	0.25kg	100pcs

# 3/4 EXTENSION SLIDE

LOAD CAPACITY  
5-8 kgf

NO SCREW

STAINLESS  
304  
STEEL

ESR2

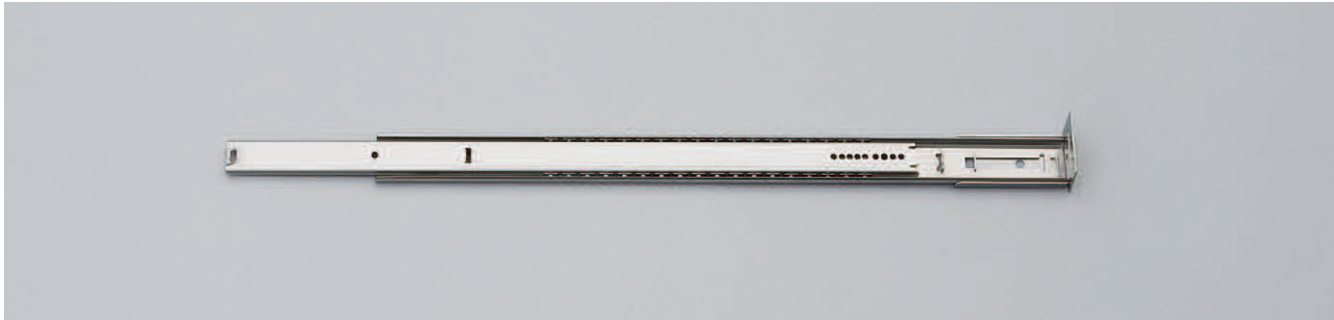

- Under carriage mounting with bracket.
- 3/4 extension.
- Front disconnect.
- Friction brake stop.
- \* Mount with M4 or #8 Binding, Pan, or Truss head screws.
- \* Two plastic tacks supplied per slide.

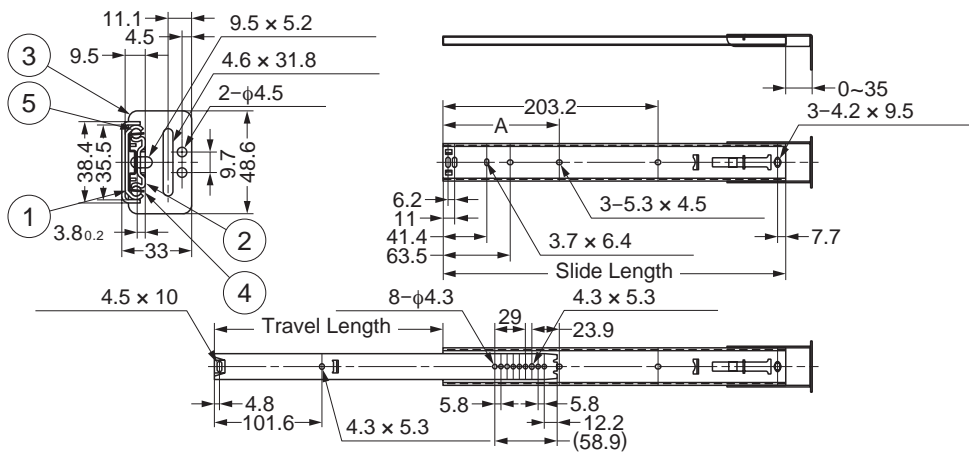

No.	Part Name	Material	Finish
①	Outer Rail	Stainless Steel (SUS304)	Plain
②	Inner Rail	Stainless Steel (SUS304)	Plain
③	Bracket	Stainless Steel (SUS304)	Plain
④	Retainer	Stainless Steel (SUS304)	Plain
⑤	Balls	Stainless Steel (SUS304)	-

Item Code	Item Name	Slide Length	Travel Length	A	Load Capacity(pcs)		Weight(pc)	Box
190-111-310	ESR2-12	323.8	215.9	109.9	78.4N	8kgf	0.4kg	20pcs
190-111-311	ESR2-14	374.6	266.7	160.7	73.5N	7.5kgf	0.43kg	20pcs
190-111-312	ESR2-16	425.4	304.8	-	68.6N	7 kgf	0.48kg	20pcs
190-111-313	ESR2-18	476.2	317.5	262.3	68.6N	7 kgf	0.53kg	20pcs
190-111-314	ESR2-20	527	368.3	313.1	63.7N	6.5kgf	0.57kg	20pcs
190-111-315	ESR2-22	577.8	419.1	363.9	58.8N	6kgf	0.62kg	20pcs
190-111-316	ESR2-24	628.6	444.5	414.7	53.9N	5.5kgf	0.66kg	20pcs
190-111-317	ESR2-26	679.4	495.3	465.5	49N	5kgf	0.71kg	20pcs

# LINEAR BALL BEARING GUIDE



TSSL

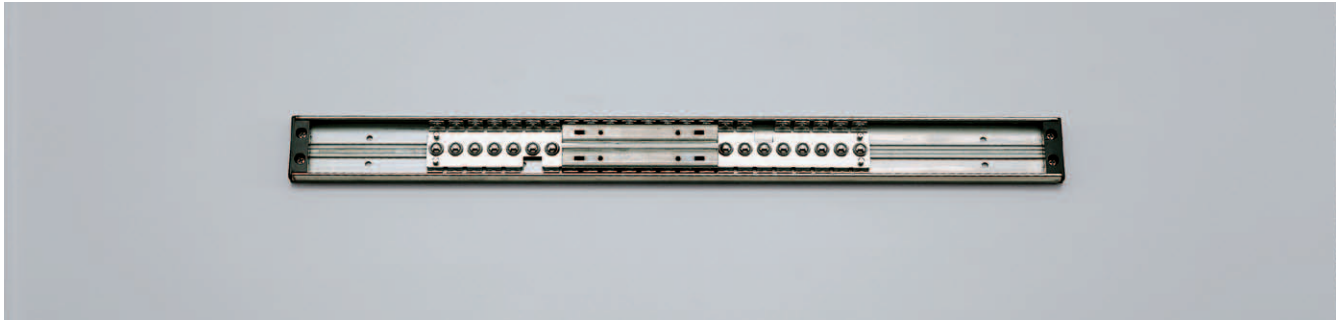

- Stainless steel slide.
- 3 rows of carbon steel balls to ensure smooth travel.
- Inner rail is located inside the retainer for precise movement.
- Non handed.
- Available in length up to 2,000mm.  
Please contact your local dealer for special sizes.

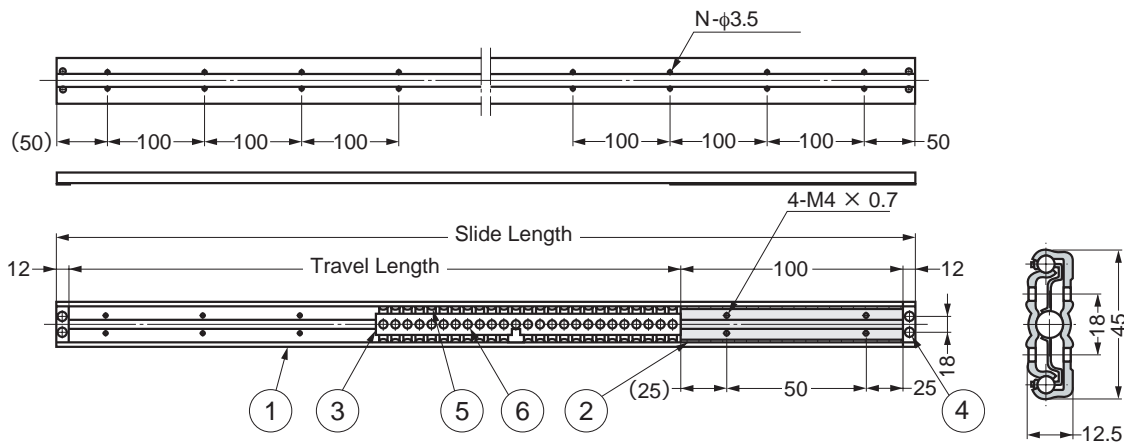

No.	Part Name	Material	Finish/Color
①	Outer Rail	Stainless Steel (SUS304)	Plain
②	Inner Rail	Stainless Steel (SUS304)	Plain
③	Retainer	Stainless Steel (SUS304)	Plain
④	End stopper	Polyamide	Black
⑤	Ball	Carbon steel	—
⑥	Ball	Carbon steel	—

Item Code	Item Name	Slide Length	Travel Length	Holes	Weight(pc)	Carton
190-110-600	TSSL-300-100	300	176	6	0.46kg	12pcs
190-110-601	TSSL-400-100	400	276	8	0.57kg	12pcs
190-110-602	TSSL-500-100	500	376	10	0.68kg	12pcs
190-110-603	TSSL-600-100	600	476	12	0.80kg	12pcs
190-110-604	TSSL-800-100	800	676	16	1.05kg	12pcs
190-110-605	TSSL-1000-100	1000	876	20	1.30kg	12pcs

# LINEAR BALL BEARING GUIDE

LOAD CAPACITY  
5 kgf

NO SCREW

STAINLESS  
304  
STEEL

ESR9

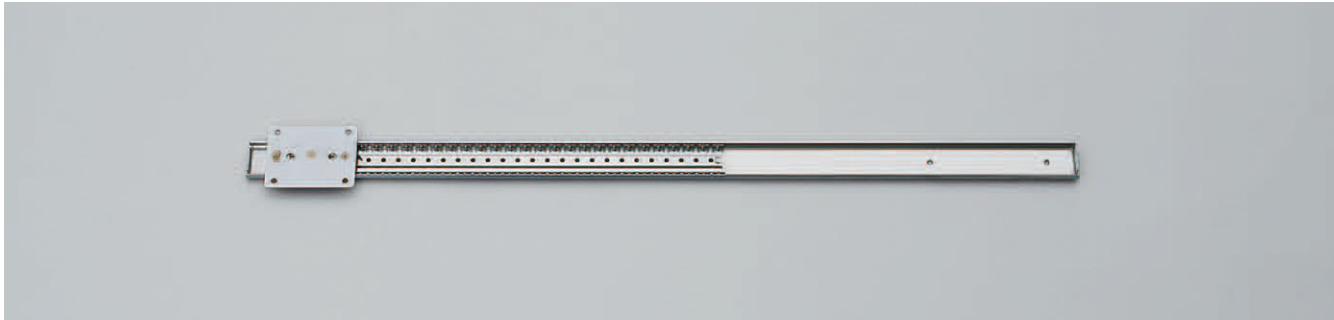

- Mounting plate attached type.
- \* Mount with M4 or #8 Binding, Pan, or Truss head screws.

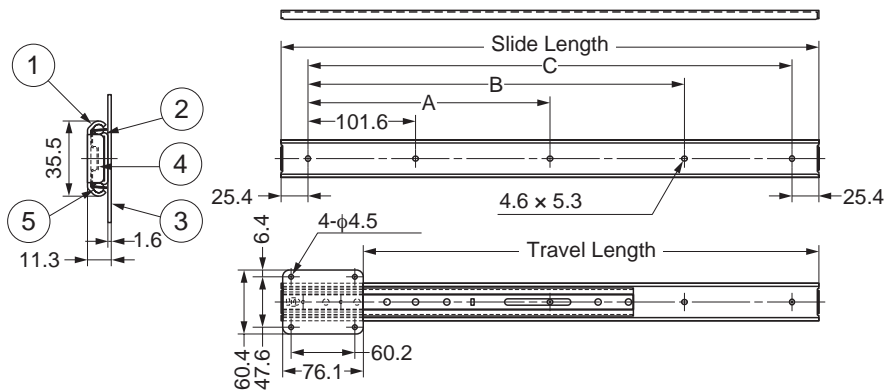

No.	Part Name	Material	Finish
①	Outer Rail	Stainless Steel (SUS304)	Plain
②	Inner Rail	Stainless Steel (SUS304)	Plain
③	Mounting Plate	Stainless Steel (SUS304)	Plain
④	Retainer	Stainless Steel (SUS304)	Plain
⑤	Balls	Stainless Steel (SUS304)	Plain

Item Code	Item Name	Slide Length	Travel Length	A	B	C	Load Capacity(pair)	Weight	Box
190-111-336	ESR9-12	304.8	225	—	152.4	254	5kgf	0.14kg	22pcs
190-111-337	ESR9-14	355.6	276	—	203.2	304.8		0.16kg	22pcs
190-111-338	ESR9-16	406.4	327	—	254	355.6		0.17kg	22pcs
190-111-339	ESR9-18	457.2	378	203.2	304.8	406.4		0.19kg	22pcs
190-111-340	ESR9-20	508	428	228.6	355.6	457.2		0.20kg	22pcs
190-111-341	ESR9-22	558.8	479	254	406.4	508		0.22kg	22pcs
190-111-342	ESR9-24	609.6	530	279.4	457.2	558.8		0.24kg	22pcs
190-111-343	ESR9-26	660.4	581	304.8	508	609.6		0.25kg	22pcs
190-111-344	ESR9-28	711.2	632	330.2	558.8	660.4		0.27kg	22pcs



# DRAWER RUNNER



# RKA5



- 3/4 extensions.
- Stainless steel slide.
- Urethan rollers provide smooth and silent movement.
- Self-closing function.
- Sold in pairs.

### Installation

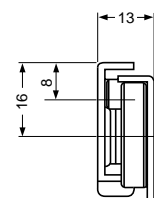
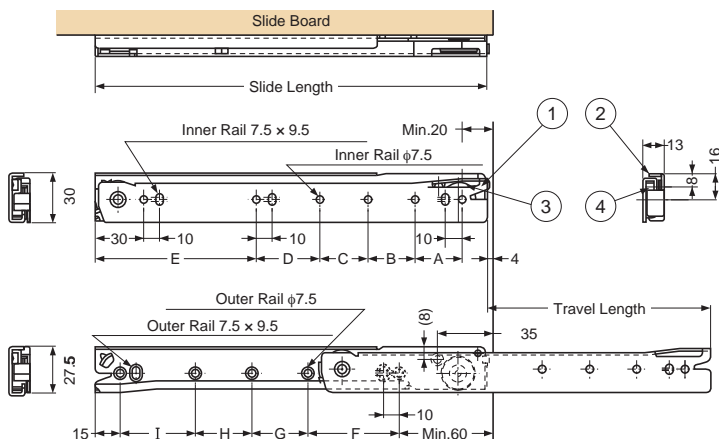
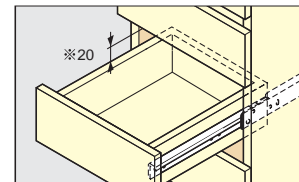

No.	Part Name	Material	Finish
①	Inner Rail	Stainless Steel (SUS430)	—
②	Outer Rail	Stainless Steel (SUS430)	—
③	Roller	Polyurethane	Black
④	Roller	Polyacetal	Natural
④	Guide	Polyacetal	Natural

Item Code	Item Name	Slide Length	Travel Length	Inner Rail						Outer Rail					Load Capacity (pair)	Weight (pair)	Box	
				A	B	C	D	E	Holes	F	G	H	I	Holes				
190-110-170	RKA5-300(SUS430)	296	205	165	—	—	—	115	6	112.5	112.5	—	—	6	147N	15kgf	0.48kg	20pair
190-110-171	RKA5-350(SUS430)	346	250	105	105	—	—	120	7	91.5	92	91.5	—	7	147N	15kgf	0.57kg	20pair
190-110-172	RKA5-400(SUS430)	396	295	127.5	127.5	—	—	125	7	108.5	108	108.5	—	7	147N	15kgf	0.65kg	20pair
190-110-173	RKA5-450(SUS430)	446	340	100	100	100	—	130	8	125	125	125	—	7	147N	15kgf	0.70kg	10pair
190-110-174	RKA5-500(SUS430)	496	380	113	114	113	—	140	8	106	106.5	106.5	106	8	147N	15kgf	0.82kg	10pair
190-110-175	RKA5-550(SUS430)	546	420	126.5	127	126.5	—	150	8	119	118.5	118.5	119	8	147N	15kgf	0.90kg	10pair
190-110-176	RKA5-600(SUS430)	596	460	105	105	105	105	160	9	131.5	131	131	131.5	8	147N	15kgf	0.98kg	10pair

# DRAWER DAMPER



# GDSR144-R



- Latch required to hold drawer at closing position.
- Reduce drawer closing speed.

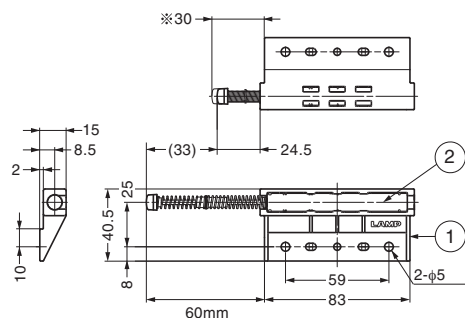

### Application

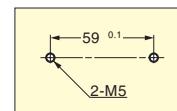
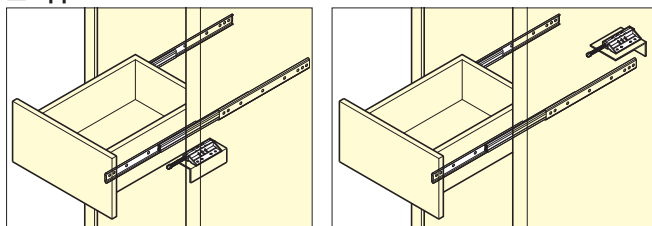

Item Code	Item Name	Reaction Force	Weight	Box
190-118-835	GDSR144-R	20N	2kgf	24g

No.	Part Name	Material	Finish
①	Bracket	ABS Plastic	Light Grey
②	Body	Polyacetal	Grey
③	Bumper	Polyurethane	Red

# SOFT CLOSE SLIDE - SIDE MOUNT



4070



- Self & Soft closing slide.
- Full extension.
- Front disconnect for easy removal of the drawer.
- Sold in pairs.

### Self & Soft-Closing

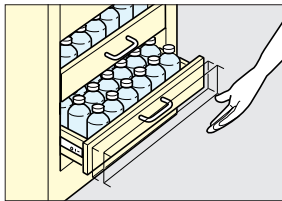

### Full Extension

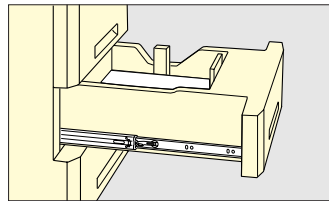

### Front Disconnect

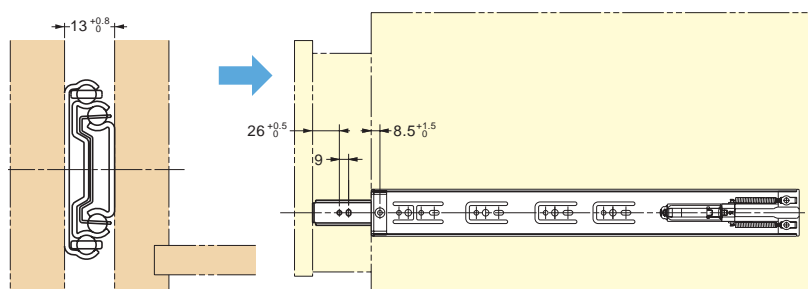
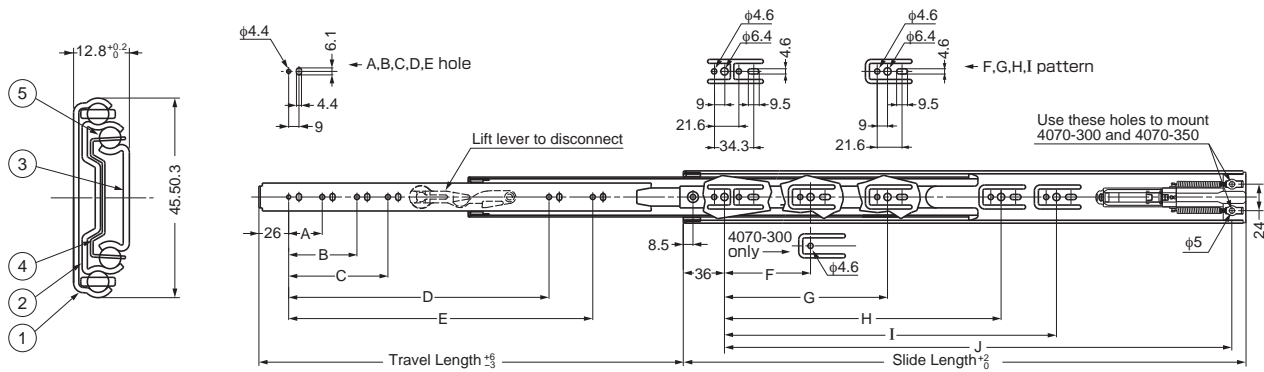
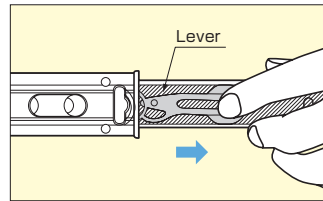

No.	Part Name	Material	Finish
①	Outer Rail	Steel	Clear Zinc Chromate
②	Intermediate Member	Steel	Clear Zinc Chromate
③	Inner Rail	Steel	Clear Zinc Chromate
④	Retainer	Steel	(Zinc coating)
⑤	Balls	Steel	-

Item Code	Item Name	Slide Length	Travel Length	A	B	C	D	E	F	G	H	I	J	Load Capacity(pair)	Weight(pair)	Box	
190-111-516	4070-300	300	238	-	-	-	-	156	119	-	-	-	252.5	200N	20kgf	0.74kg	10pair
190-111-517	4070-350	350	305	-	-	-	-	200	128	-	-	-	302.5	250N	25kgf	0.90kg	10pair
190-111-518	4070-400	400	378	96	-	-	-	256	128	208	-	-	352.5	350N	35kgf	1.03kg	10pair
190-111-519	4070-450	450	430	128	-	-	-	294	128	256	-	-	402.5	400N	40kgf	1.18kg	10pair
190-111-520	4070-500	500	482	96	160	-	-	344	128	304	-	-	452.5	450N	45kgf	1.32kg	10pair
190-111-521	4070-550	550	533	96	160	352	-	394	128	224	352	-	502.5	400N	40kgf	1.48kg	6pair
190-111-522	4070-600	600	584	128	192	384	-	444	128	224	352	-	552.5	350N	35kgf	1.63kg	6pair
190-111-523	4070-650	650	635	128	224	416	-	494	128	224	352	448	602.5	350N	35kgf	1.77kg	6pair
190-111-524	4070-700	700	685	128	224	416	480	544	128	224	352	496	652.5	350N	35kgf	1.92kg	6pair

# SOFT CLOSE SLIDE - UNDER MOUNT



4071



- Under mount type.
- Smooth and elegant soft-close mechanism.
- Full extension.
- Front disconnect - easily remove drawer".

### Self & Soft-Closing

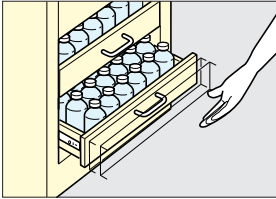

### Full Extension

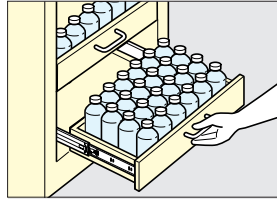

### Front Disconnect

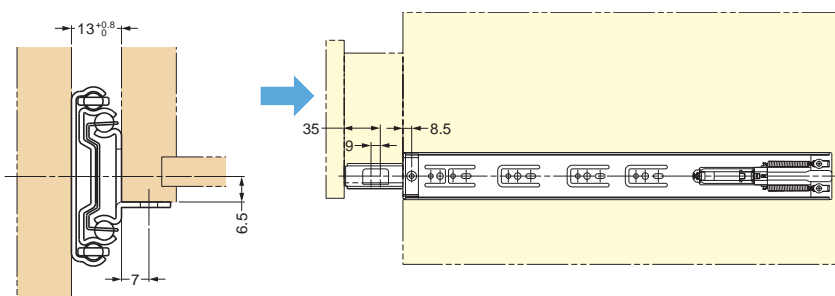
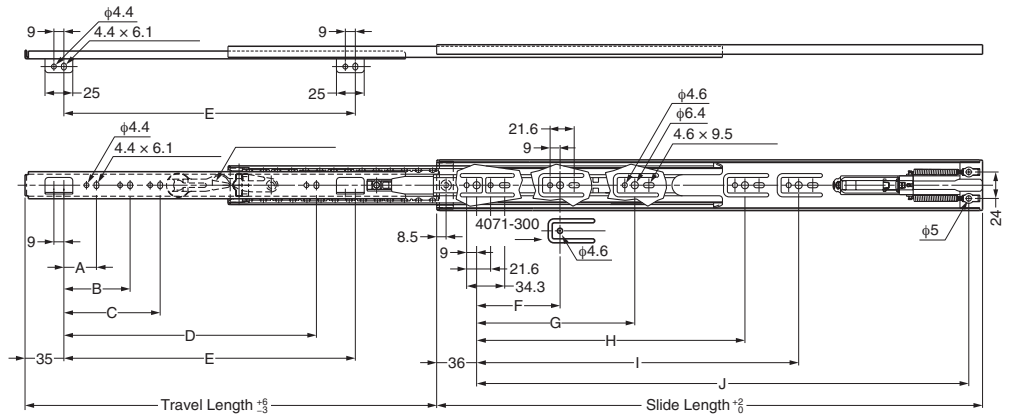
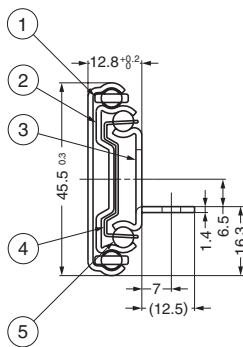
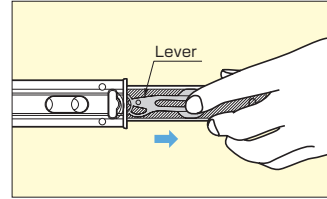

No.	Part Name	Material	Finish
①	Outer Rail	Steel	Clear Zinc Chromate
②	Intermediate Member	Steel	Clear Zinc Chromate
③	Inner Rail	Steel	Clear Zinc Chromate
④	Retainer	Steel	(Zinc Chromate Steel)
⑤	Balls	Steel	—

Item Code	Item Name	Slide Length	Travel Length	A	B	C	D	E	F	G	H	I	J	Load Capacity (pair)	Weight (pair)	Box	
190-110-880	4071-300	300	238	32	—	—	—	156	119	—	—	—	252.5	200N	20kgf	0.78kg	10pairs
190-110-881	4071-350	350	305	64	—	—	—	200	128	—	—	—	302.5	250N	25kgf	0.89kg	10pairs
190-110-882	4071-400	400	378	96	—	—	—	250	128	208	—	—	352.5	350N	35kgf	1.03kg	10pairs
190-110-883	4071-450	450	430	128	—	—	—	294	128	256	—	—	402.5	400N	40kgf	1.19kg	10pairs
190-110-884	4071-500	500	482	96	160	—	—	344	128	304	—	—	452.5	450N	45kgf	1.34kg	10pairs
190-110-885	4071-550	550	533	96	160	352	—	394	128	224	352	—	502.5	400N	40kgf	1.5kg	10pairs
190-110-886	4071-600※	600	584	128	192	384	—	444	128	224	352	—	552.5	350N	35kgf	—	10pairs
190-110-887	4071-650※	650	635	128	224	416	—	494	128	224	352	448	602.5	350N	35kgf	—	10pairs
190-110-888	4071-700※	700	685	128	224	416	480	544	128	224	352	496	652.5	350N	35kgf	—	10pairs

※ made-to-order

# PUSH TO OPEN SLIDE - SIDE MOUNT



4060

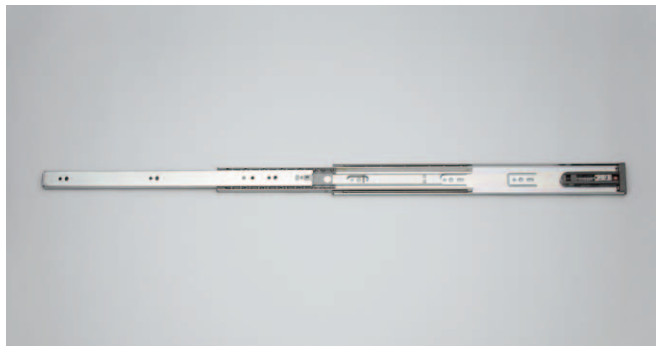

- Push to open.
- No handle or knobs required for a sleek modern look.
- Push again to close – drawer slide automatically latches, no other latches or catches required.
- Front disconnect – easy remove drawer.
- Full extension maximizes load capacity.

### Push Open

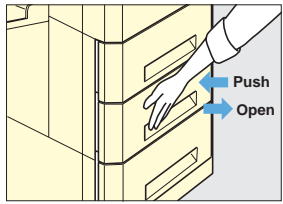

### Full Extension

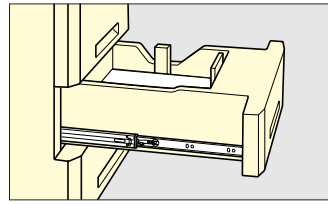

### Front Disconnect

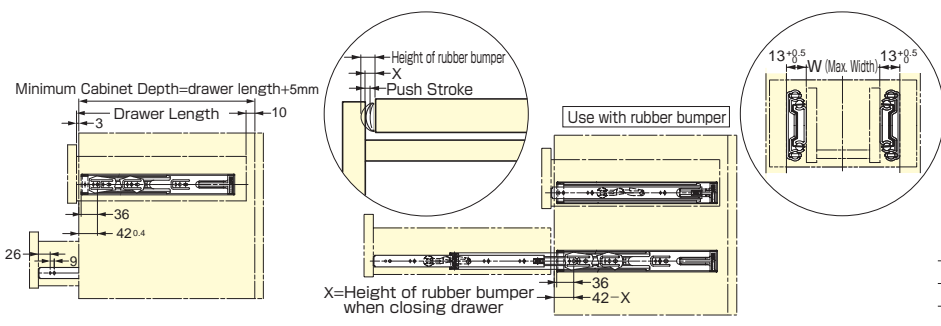
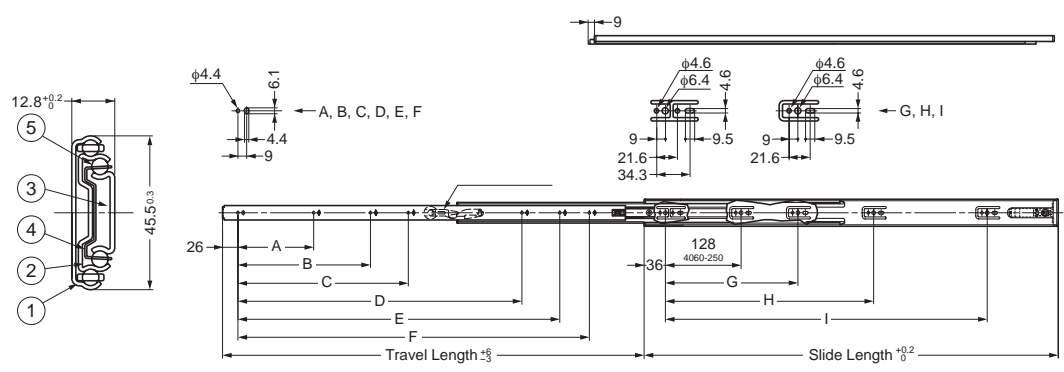
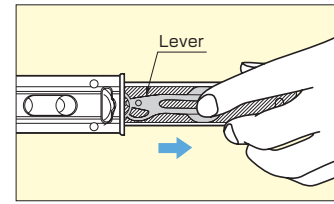

No.	Part Name	Material	Finish
①	Outer Rail	Steel	Clear Zinc Chromate
②	Intermediate Member	Steel	Clear Zinc Chromate
③	Inner Rail	Steel	Clear Zinc Chromate
④	Retainer	Steel	Zinc Chromate Steel
⑤	Balls	Steel	—

Item Code	Item Name	Slide Length	Travel Length	A	B	C	D	E	F	G	H	I	W	Load Capacity(pair)		Weight(pair)	Box
190-111-525	4060-250	250	238	—	—	—	—	—	156	—	—	106	450	200N	20kgf	0.70kg	10pairs
190-111-526	4060-300	300	305	—	—	—	—	—	200	—	—	128	500	250N	25kgf	0.84kg	10pairs
190-111-527	4060-350	350	356	96	—	—	—	—	256	—	—	192	550	350N	35kgf	0.96kg	10pairs
190-111-528	4060-400	400	406	128	—	—	—	—	294	—	—	224	600	400N	40kgf	1.10kg	10pairs
190-111-529	4060-450	450	457	96	160	—	—	—	344	—	—	288	650	450N	45kgf	1.29kg	10pairs
190-111-530	4060-500	500	508	96	160	352	—	—	394	224	—	352	700	450N	45kgf	1.42kg	10pairs
190-111-531	4060-550	550	559	128	192	384	—	—	444	224	—	352	750	400N	40kgf	1.57kg	6pairs
190-111-532	4060-600	600	610	128	224	416	—	—	494	224	352	448	800	400N	40kgf	1.71kg	6pairs
190-111-533	4060-650	650	660	128	224	416	480	—	544	224	352	480	850	350N	35kgf	1.88kg	6pairs
190-111-534	4060-700	700	711	128	224	288	480	544	594	224	352	544	900	350N	35kgf	2.04kg	6pairs

# PUSH TO OPEN SLIDE - UNDER MOUNT



4061



- Push to open.
- No handle or knobs required for a sleek modern look.
- Push again to close – drawer slide automatically latches, no other latches or catches required.
- Front disconnect – easy remove drawer.
- Full extension maximizes load capacity.

### Push Open

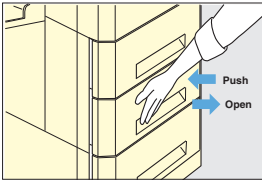

### Full Extension

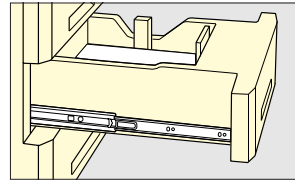

### Front Disconnect

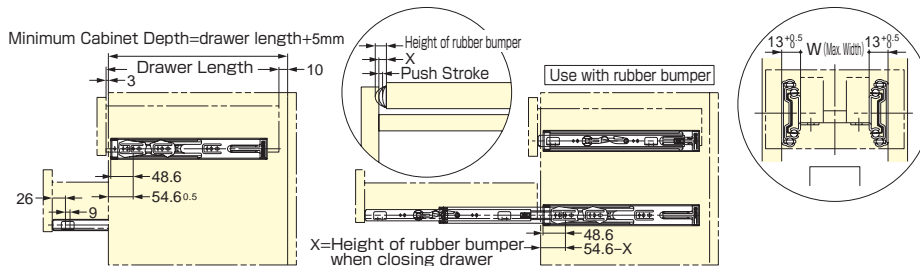
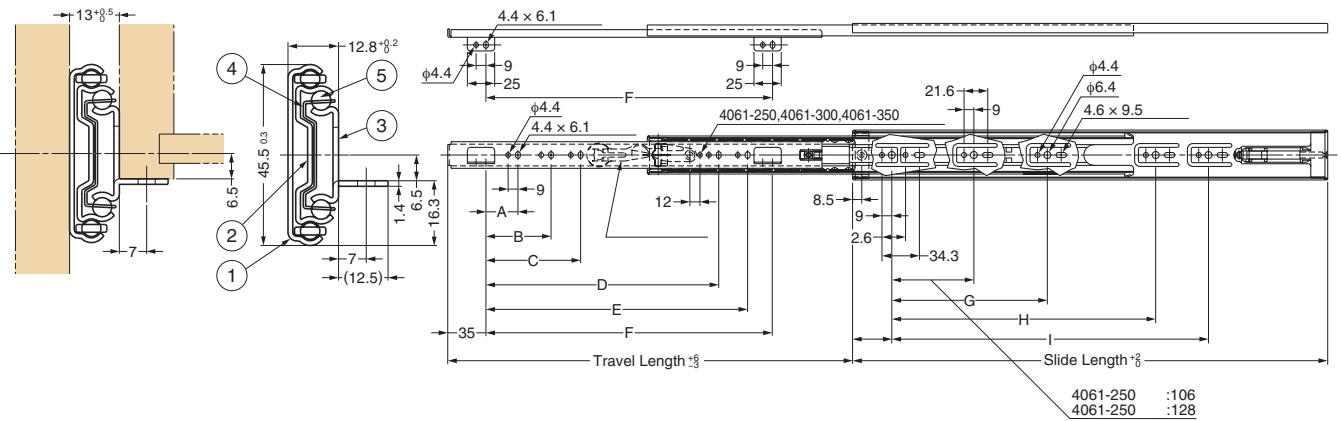
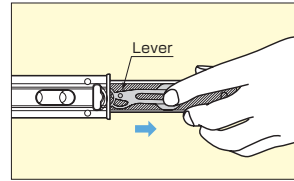

No.	Part Name	Material	Finish
①	Outer Rail	Steel	Clear Zinc Chromate
②	Intermediate Member	Steel	Clear Zinc Chromate
③	Inner Rail	Steel	Clear Zinc Chromate
④	Retainer	Steel	Zinc Chromate Steel
⑤	Balls	Steel	—

Item Code	Item Name	Slide Length	Travel Length	A	B	C	D	E	F	G	H	I	W	Load Capacity(pair)		Box
190-110-889	4061-250	250	238	32	—	—	—	—	156	—	—	106	450	200N	20kgf	10pair
190-110-890	4061-300	300	305	64	—	—	—	—	200	—	—	128	500	250N	25kgf	10pair
190-110-891	4061-350	350	356	96	—	—	—	—	256	—	—	192	550	350N	35kgf	10pair
190-110-892	4061-400	400	406	128	—	—	—	—	294	—	—	224	600	400N	40kgf	10pair
190-110-893	4061-450	450	457	96	160	—	—	—	344	—	—	288	650	450N	45kgf	10pair
190-110-894	4061-500	500	508	96	160	352	—	—	394	224	—	352	700	450N	45kgf	10pair
190-110-895	4061-550	550	559	128	192	384	—	—	444	224	—	352	750	400N	40kgf	10pair
190-110-896	4061-600	600	610	128	224	416	—	—	494	224	352	448	800	400N	40kgf	10pair
190-110-897	4061-650	650	660	128	224	416	480	—	544	224	352	480	850	350N	35kgf	10pair
190-110-898	4061-700	700	711	128	224	288	480	544	594	224	352	544	900	350N	35kgf	10pair



# FULL EXTENSION SLIDE



**AR3**



- Full extension.
- Positive stop.
- Non-handed.

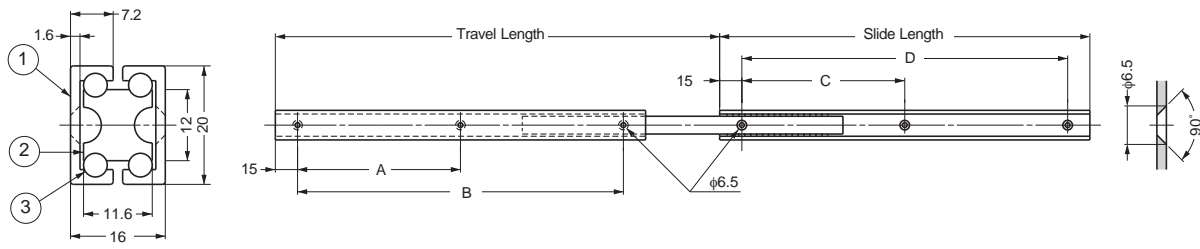

No.	Part Name	Material	Finish/Color
①	Outer Rail	Aluminum Alloy	Anodized/White
②	Inner Rail	Aluminum Alloy	Anodized/White
③	Balls	Steel	—

Item Code	Item Name	Slide Length	Travel Length	A	B	C	D	Load Capacity(pair)	Weight(pc)	Box
190-119-538	AR3-100	100	100	—	70	—	70	110N	11.2kgf	63g 500pcs
190-119-539	AR3-200	200	223	85	170	85	170	90N	9.2kgf	128g 250pcs
190-119-540	AR3-300	300	345	135	270	135	270	70N	7.1kgf	194g 125pcs
190-119-541	AR3-400	400	460	185	370	185	370	50N	5.1kgf	260g 100pcs
190-119-542	AR3-500	500	576	235	470	235	470	30N	3.1kgf	325g 100pcs

# FULL EXTENSION SLIDE (W/HOLD-OUT DETENT)



**AR3-K**



- Full extension.
- Positive stop.
- Non-handed.
- Hold-out detent.

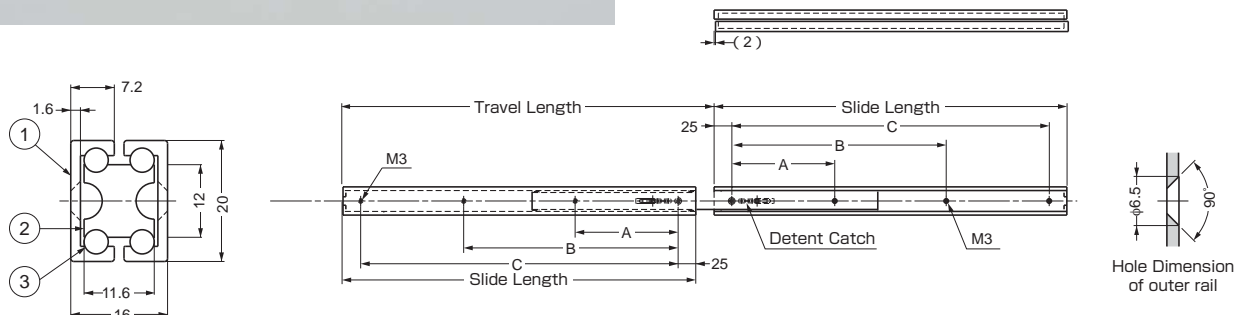

No.	Part Name	Material	Finish/Color
①	Outer Rail	Aluminum Alloy	Anodized/White
②	Inner Rail	Aluminum Alloy	Anodized/White
③	Balls	Steel	—

Item Code	Item Name	Slide Length	Travel Length	A	B	C	Load Capacity(pair)	Weight	Box
190-112-255	AR3-K200	200	214	150	—	—	105N	10.7kgf	130g 250pcs
190-112-256	AR3-K300	300	314	130	250	—	100N	10.2kgf	198g 125pcs
190-112-257	AR3-K400	400	414	130	280	350	90N	9.2kgf	263g 100pcs
190-112-258	AR3-K500	500	514	130	280	450	85N	8.7kgf	304g 100pcs

### 3/4 EXTENSION SLIDE



AR2

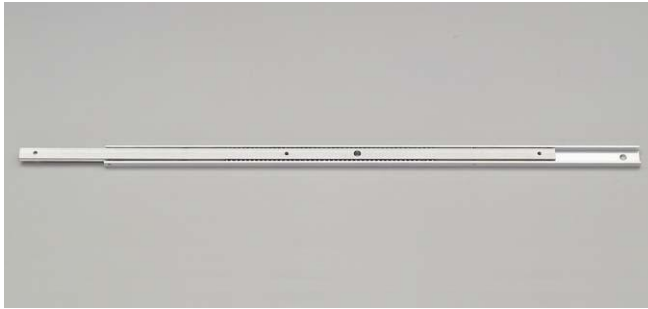

- 3/4 extension.
- Positive stop.
- Non-handed.

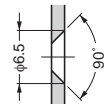
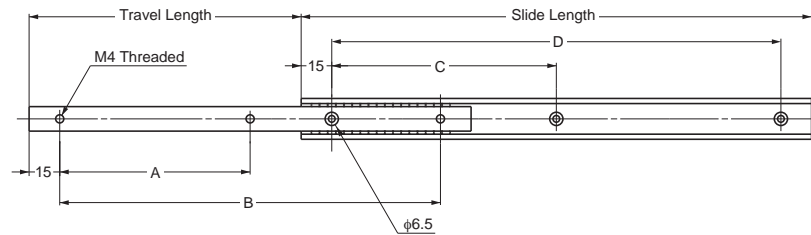
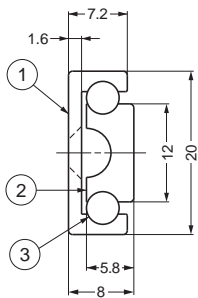

No.	Part Name	Material	Finish/Color
①	Outer Rail	Aluminum Alloy	Anodized/White
②	Inner Rail	Aluminum Alloy	Anodized/White
③	Balls	Steel	—

Item Code	Item Name	Slide Length	Travel Length	A	B	C	D	Load Capacity(pair)		Weight	Box
190-119-533	AR2-100	100	60	—	70	—	70	150N	15.3kgf	31g	1000pcs
190-119-534	AR2-200	200	120	85	170	85	170	120N	12.2kgf	63g	500pcs
190-119-535	AR2-300	300	180	135	270	135	270	100N	10.2kgf	76g	250pcs
190-119-536	AR2-400	400	240	185	370	185	370	90N	9.2kgf	129g	200pcs
190-119-537	AR2-500	500	300	235	470	235	470	80N	8.2kgf	161g	200pcs

### 3/4 EXTENSION SLIDE (W/HOLD-OUT DETENT)



AR2-K

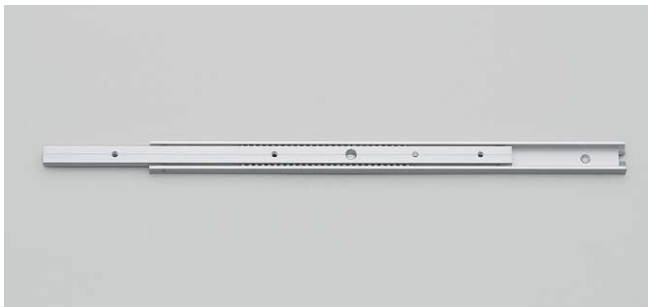

- 3/4 extension.
- Positive stop.
- Non-handed.
- Hold-out detent.

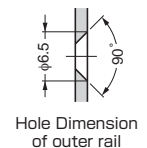
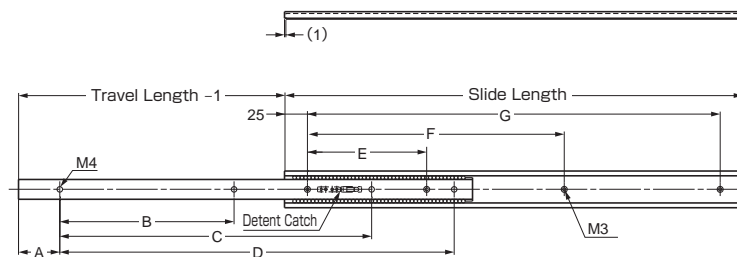
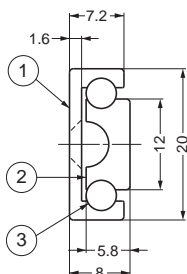

No.	Part Name	Material	Finish/Color
①	Outer Rail	Aluminum Alloy	Anodized/White
②	Inner Rail	Aluminum Alloy	Anodized/White
③	Balls	Steel	—

Item Code	Item Name	Slide Length	Travel Length	A	B	C	D	E	F	G	Load Capacity(pair)		Weight	Box
190-112-251	AR2-K200	200	110	25	60	160	—	150	—	—	125N	12.7kgf	64g	500pcs
190-112-252	AR2-K300	300	170	45	100	230	—	130	250	—	110N	11.2kgf	97g	250pcs
190-112-253	AR2-K400	400	230	45	150	270	330	130	280	350	95N	9.7kgf	130g	200pcs
190-112-254	AR2-K500	500	290	45	190	340	430	130	280	450	85N	8.7kgf	162g	200pcs

# ALUMINUM MINI SLIDE



# AR3-16



- Full extension.
- Positive stop.
- Thin profile for various applications.
- Light-weight aluminum body.

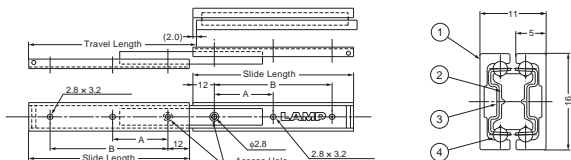

No.	Part Name	Material	Finish
①	Outer Rail	Aluminum Alloy	Anodized
②	Inner Rail	Aluminum Alloy	Anodized
③	Retainer	Steel	Zinc Chromate Steel
④	Balls	Steel	—

Item Code	Item Name	Slide Length	Travel Length	A	B	Load Capacity(pair)		Weight	Box
190-012-581	AR3-16-80	80	(77)	—	56	20N	2kgf	31.44	10pcs
190-012-582	AR3-16-100	100	(117)	38	76	29N	3kgf	35.6	10pcs
190-012-583	AR3-16-150	150	(151)	63	126	39N	4kgf	54.3	10pcs

# ALUMINUM MINI GUIDE



# ARL2-16



- Thin profile for various applications.
- Light-weight aluminum body.

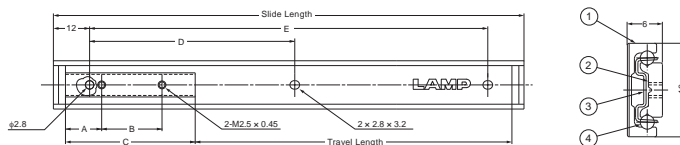

No.	Part Name	Material	Finish
①	Outer Rail	Aluminum Alloy	Anodized
②	Inner Rail	Aluminum Alloy	Anodized
③	Retainer	Steel	Zinc Chromate Steel
④	Balls	Steel	—

Item Code	Item Name	Slide Length	Travel Length	A	B	C	D	E	Load Capacity			Weight	Box	
190-012-584	ARL2-16-70	70	(30)	5	18	28	—	46	20N	2kg	8N	0.8kg	13.37g	20pcs
190-012-585	ARL2-16-100	100	(52)	10	19	39	38	76	49N	5kg	18N	1.8kg	17.98g	20pcs
190-012-586	ARL2-16-150	150	(96)	10	19	39	63	126	49N	5kg	18N	1.8kg	23.28g	20pcs

# ALUMINUM MINI SLIDE (2-WAY)



# ARW2-16



- Two-way travel.
- Thin profile for various applications.
- Light-weight aluminum body.
- Designed without positive stop for ease of assembly.
- \*Please add secondary stopper if necessary.

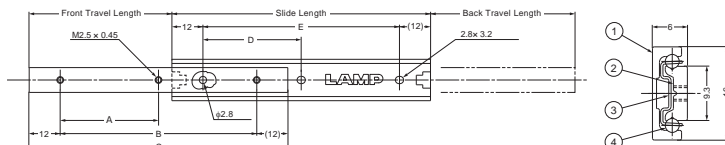

No.	Part Name	Material	Finish
①	Outer Rail	Aluminum Alloy	Anodized
②	Inner Rail	Aluminum Alloy	Anodized
③	Retainer	Steel	Zinc Chromate Steel
④	Balls	Steel	—

Item Code	Item Name	Slide Length	Front Travel Length	Back Travel Length	A	B	C	D	E	Load Capacity			Weight	Box	
190-012-578	ARW2-16-70	70	(32)	(32)	—	46	70	—	46	29N	3kg	11N	1.1kg	15.34g	20pcs
190-012-579	ARW2-16-100	100	(40)	(40)	38	76	100	38	76	49N	5kg	20N	2kg	21.2g	20pcs
190-012-580	ARW2-16-150	150	(79)	(79)	63	126	150	63	126	69N	7kg	30N	3.1kg	29.1g	20pcs



MINI GUIDE BLOCK & RAIL



MRS20, MR-20CS

- Perfect for small stroke application.
- No grease needed.

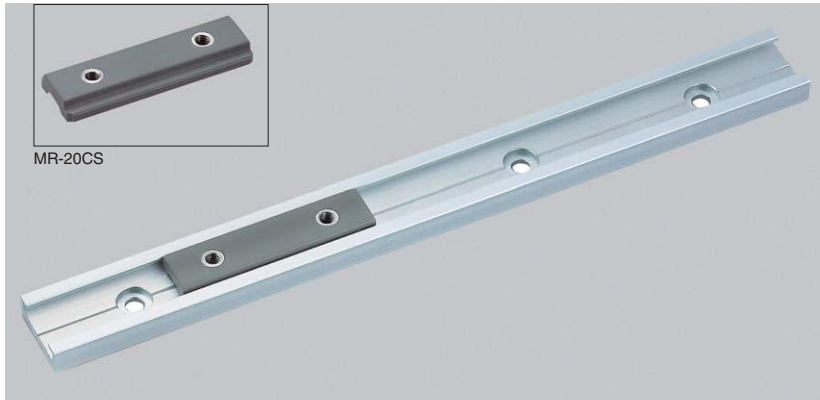

MR-20CS

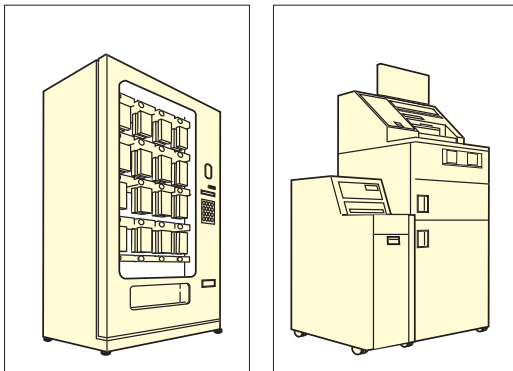
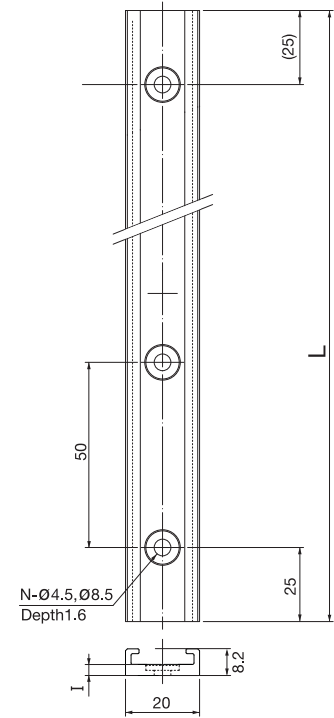
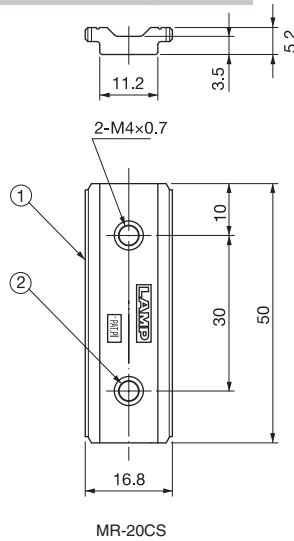

Installation

Item Code	Item Name	I	L	N	Weight	Box
190-111-491	MRS20-100	3	100	2	20g	200pcs
190-111-492	MRS20-200	3	200	4	40g	
190-111-493	MRS20-400	3	400	8	80g	100pcs
190-111-494	MRS20-800	3	800	16	160g	80pcs
190-111-495	MRS20-2000	3	2000	40	400g	30pcs

Material	Finish
Aluminum	Anodized

\*Both ends are not anodized.

No.	Material	Finish
①	Polyethylene (UL 94HB)	Grey
②	304 Stainless Steel	Plain

Item Code	Item Name	Weight	Box	Carton
190-111-496	MR-20CS	7g	50pcs	1000pcs

MRS 20, MR-20CS LOAD RATING INFORMATION

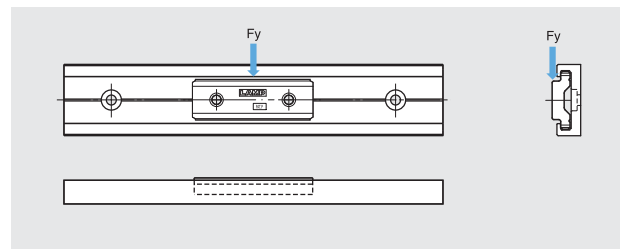
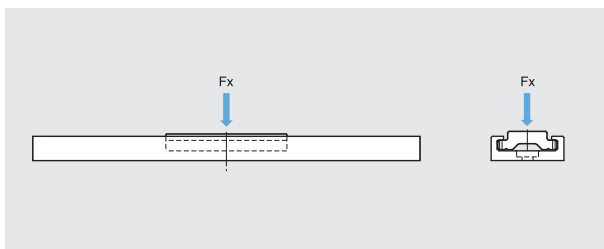

Horizontal Static Load Fx	30.6kgf
Vertical Static Load Fy	17.8kgf

◆ Reduction Factor

Certain reduction needs to be applied depending on application or environment.  
 Low speed / Low operation frequency = 70% to 100% of Load Rating.  
 Moderate speed / High operation frequency = 35% to 65% of Load Rating.  
 High operation frequency with Vibration & Shocks = 10% to 30% of Load Rating.

# GUIDE BLOCK & RAIL

# MRS30, MR-50C

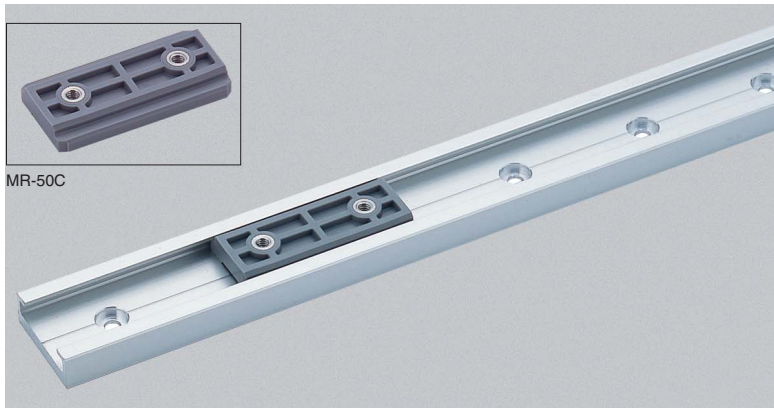

MR-50C

- Perfect for small stroke application.
- No grease needed.

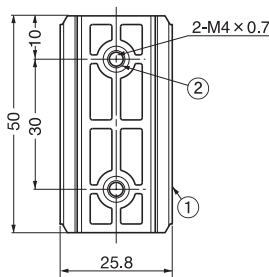
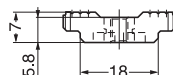
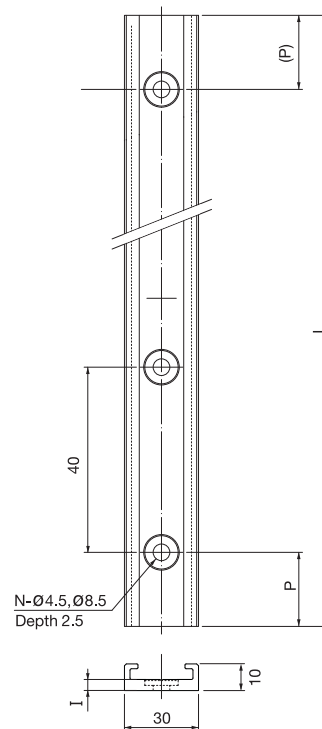

MR-50C

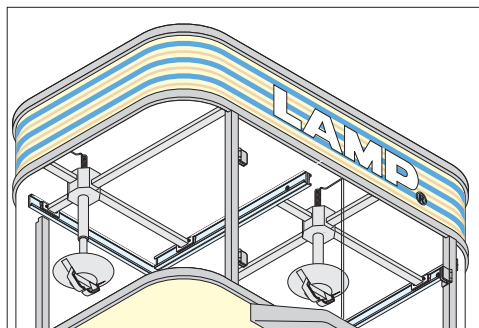

Installation

Item Code	Item Name	I	L	P	N	Weight	Box
190-112-860	MRS30-100	4	100	10	3	39g	200pcs
190-112-861	MRS30-200	4	200	20	5	79g	100pcs
190-112-862	MRS30-400	4	400		10	159g	50pcs
190-112-863	MRS30-800	4	800		20	312g	40pcs
190-112-864	MRS30-2000	4	2000		50	790g	15pcs

Material	Finish
Aluminum	Anodized

\*Both ends are not anodized.

No.	Material	Finish
①	Polyethylene (UL 94HB)	Grey
②	304 Stainless Steel	Plain

Item Code	Item Name	Weight	Box	Carton
190-111-489	MR-50C	7g	50pcs	1000pcs

## MRS 30, MR-50C LOAD RATING INFORMATION

Dynamic Friction Coefficient: 1

Maximum PV (Pressure (kgf-mm<sup>2</sup>) x Velocity (m/min.))=3.06

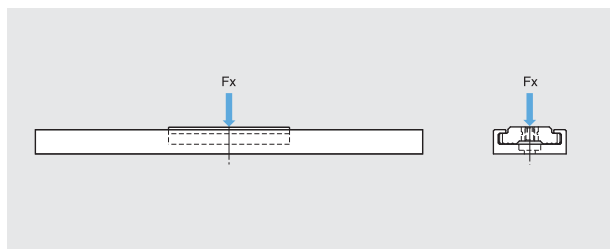

Horizontal Static Load Fx	26kgf
Vertical Static Load Fy	15kgf
Vertical Dynamic Load Mx	25kgf-cm
Horizontal Dynamic Load My	12.5kgf-cm
Horizontal Dynamic Load Mz	12.5kgf-cm

### ◆ Reduction Factor

Certain reduction needs to be applied depending on application or environment.  
 Low speed / Low operation frequency = 70% to 100% of Load Rating.  
 Moderate speed / High operation frequency = 35% to 65% of Load Rating.  
 High operation frequency with Vibration & Shocks = 10% to 30% of Load Rating.

# FULL EXTENSION SLIDE

LOAD CAPACITY  
450-950 kgf

NO SCREW

STAINLESS  
304  
STEEL

# CBL-E1908

- Full extension.
- Positive stop.

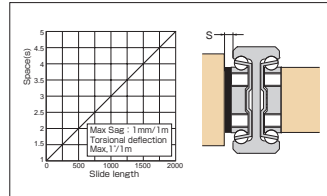
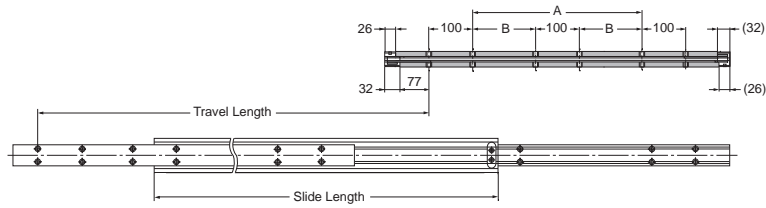
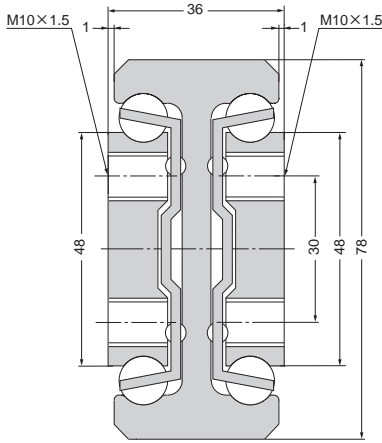

Part Name	Material/Finish
Rail	Stainless Steel(SUS304)
Balls	Stainless Steel
Retainer	Stainless Steel(SUS304), Polyamid

Item Code	Item Name	Slide Length	Travel Length	A	B	Load Capacity(pair)		Weight
190-116-322	CBL-E1908-500	500	500	100	—	8820N	900kgf	8kg
190-116-323	CBL-E1908-600	600	600	200	—	9310N	950kgf	9.6kg
190-116-324	CBL-E1908-700	700	700	300	—	8820N	900kgf	11.2kg
190-116-325	CBL-E1908-800	800	800	—	150	8330N	850kgf	12.8kg
190-116-326	CBL-E1908-900	900	900	—	200	7840N	800kgf	14.4kg
190-116-327	CBL-E1908-1000	1000	1000	—	250	7350N	750kgf	16kg
190-116-328	CBL-E1908-1100	1100	1100	—	300	6860N	700kgf	17.6kg
190-116-329	CBL-E1908-1200	1200	1200	—	350	6370N	650kgf	19.2kg
190-116-330	CBL-E1908-1300	1300	1300	—	400	5880N	600kgf	20.8kg
190-116-331	CBL-E1908-1400	1400	1400	—	450	5390N	550kgf	22.4kg
190-116-332	CBL-E1908-1500	1500	1500	—	500	4900N	500kgf	24kg
190-116-333	CBL-E1908-1600	1600	1600	—	550	4410N	450kgf	25.6kg

# FULL EXTENSION SLIDE

LOAD CAPACITY  
290-565 kgf

NO SCREW

STAINLESS  
304  
STEEL

# CBL-E1708

- All stainless steel.
- Full extension.
- Positive stop.

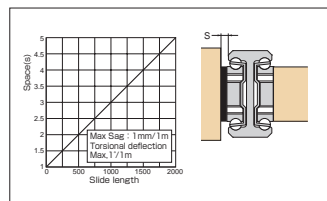
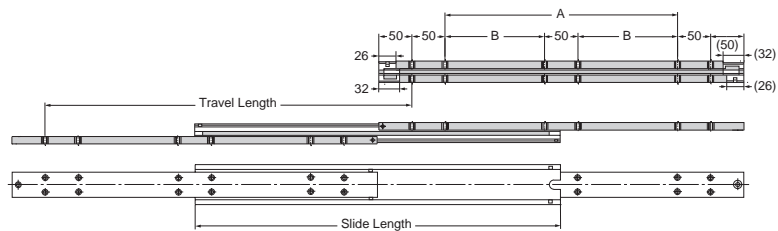
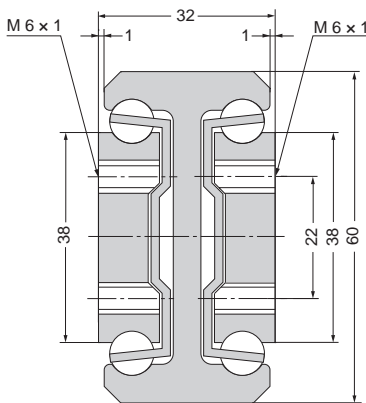

Part Name	Material/Finish
Rail	Stainless Steel(SUS304)
Balls	Stainless Steel
Retainer	Stainless Steel(SUS304), Polyamide

Item Code	Item Name	Slide Length	Travel Length	A	B	Load Capacity(pair)		Weight
190-116-692	CBL-E1708-500	500	500	300	—	5390N	550kgf	5.5kg
190-116-694	CBL-E1708-600	600	600	—	175	5537N	565kgf	6.6kg
190-116-696	CBL-E1708-700	700	700	—	225	5243N	535kgf	7.7kg
190-116-698	CBL-E1708-800	800	800	—	275	4900N	500kgf	8.8kg
190-110-018	CBL-E1708-900	900	900	—	325	4557N	465kgf	9.9kg
190-116-702	CBL-E1708-1000	1000	1000	—	375	4214N	430kgf	11kg
190-116-703	CBL-E1708-1100	1100	1100	—	425	3871N	395kgf	12.1kg
190-116-704	CBL-E1708-1200	1200	1200	—	475	3528N	360kgf	13.2kg
190-116-705	CBL-E1708-1300	1300	1300	—	525	3185N	325kgf	14.3kg
190-116-706	CBL-E1708-1400	1400	1400	—	575	2842N	290kgf	15.4kg

# FULL EXTENSION SLIDE

LOAD CAPACITY  
100-130 kgf

NO SCREW

STAINLESS  
304  
STEEL

# CBL-ST508

- All stainless steel.
- Full extension.
- Positive stop.
- Options : Positive lock Positive Catch.

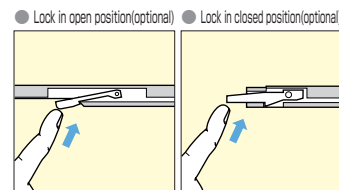
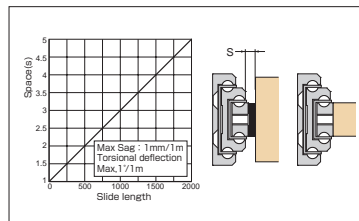
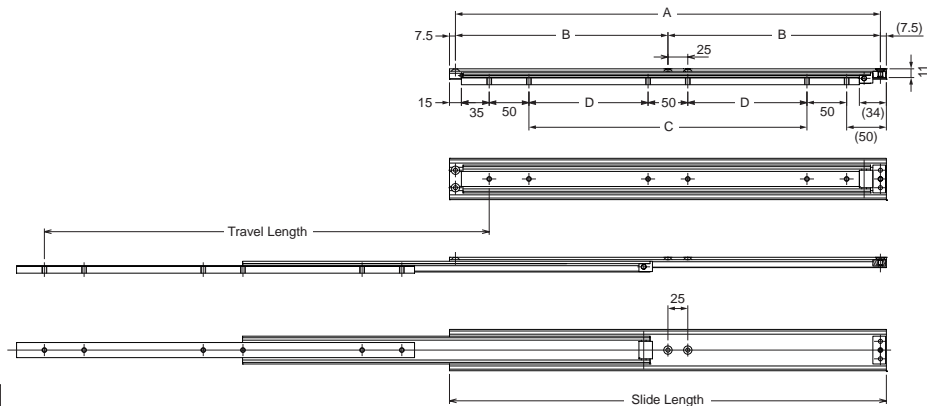
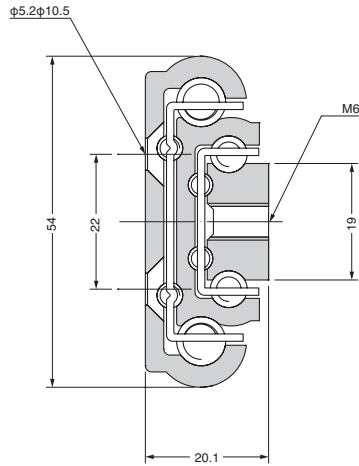

Part Name	Material/Finish
Rail	Stainless Steel(SUS304)
Balls	Stainless Steel
Retainer	Stainless Steel(SUS304), Polyamide

Item Code	Item Name	Slide Length	Travel Length	A	B	C	D	Load Capacity(pair)	Weight
190-116-684	CBL-ST508-300	300	315	285	—	100	—	1275N / 130kgf	1.35kg
190-116-686	CBL-ST508-400	400	415	385	—	200	—	1177N / 120kgf	1.8kg
190-116-688	CBL-ST508-500	500	515	485	—	300	—	1079N / 110kgf	2.25kg
190-116-690	CBL-ST508-600	600	615	—	292.5	—	175	981N / 100kgf	2.7kg

# 3/4 EXTENSION SLIDE

LOAD CAPACITY  
50-120 kgf

NO SCREW

STAINLESS  
304  
STEEL

# CBL-ST58

- 3/4 extension.
- Positive stop.
- Options: Two way travel. Positive catch. Positive lock.

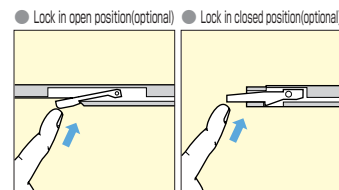
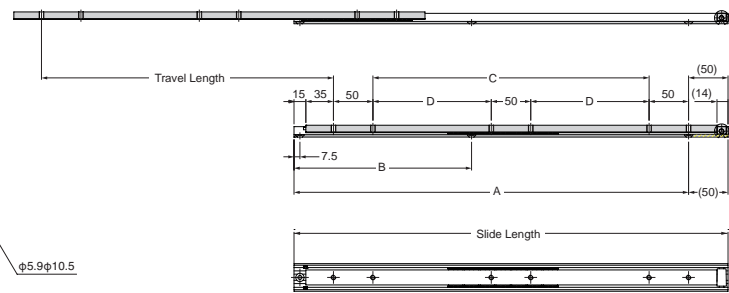
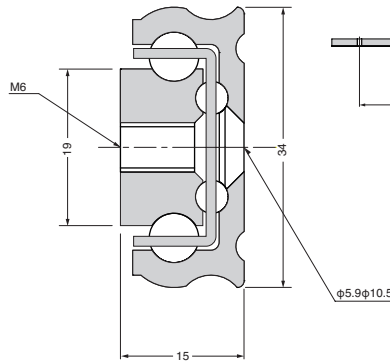

Part Name	Material/Finish
Rail	Stainless Steel(SUS304)
Balls	Stainless Steel
Retainer	Stainless Steel(SUS304), Polyamide

Item Code	Item Name	Slide Length	Travel Length	A	B	C	D	Load Capacity(pair)	Weight
190-116-840	CBL-ST58-300	300	180	250	—	100	—	1177N / 120kgf	0.9kg
190-116-842	CBL-ST58-400	400	280	350	150	200	—	1079N / 110kgf	1.2kg
190-116-844	CBL-ST58-500	500	340	450	200	300	—	981N / 100kgf	1.5kg
190-116-846	CBL-ST58-600	600	400	550	250	—	175	883N / 90kgf	1.8kg
190-116-847	CBL-ST58-700	700	480	650	300	—	225	785N / 80kgf	2.1kg
190-116-848	CBL-ST58-800	800	540	750	350	—	275	687N / 70kgf	2.4kg
190-116-849	CBL-ST58-900	900	600	850	400	—	325	588N / 60kgf	2.7kg
190-116-850	CBL-ST58-1000	1000	680	950	450	—	375	490N / 50kgf	3kg

# FULL EXTENSION SLIDE

LOAD CAPACITY  
40~80 kgf

NO SCREW

STAINLESS  
304  
STEEL

# CBL-ST448

- Over travel.
- Positive stop.

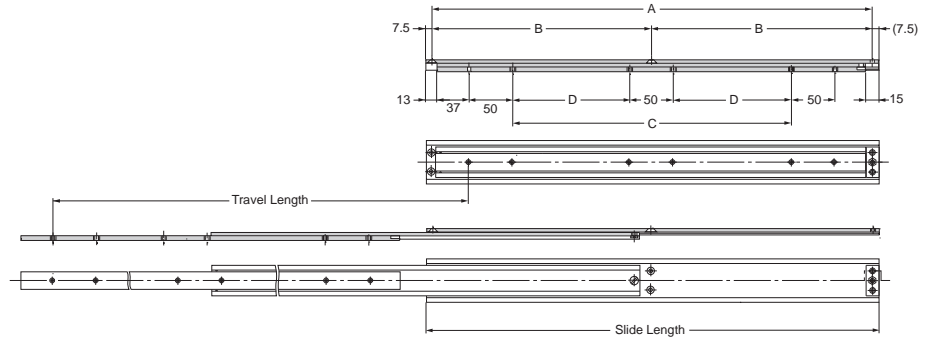
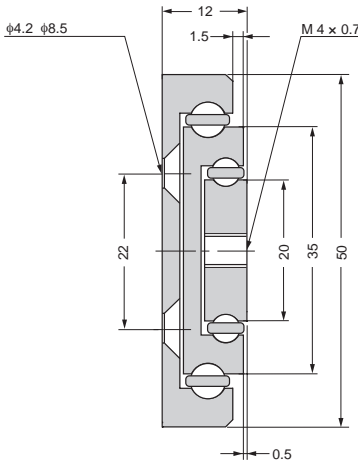

● Lock in open position(optional) ● Lock in closed position(optional)

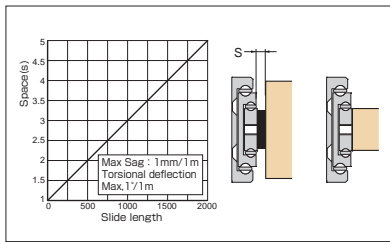
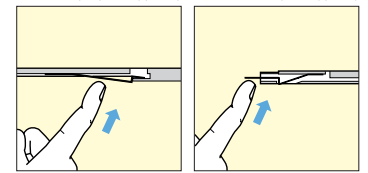

Part Name	Material/Finish
Rail	Stainless Steel(SUS304)
Balls	Stainless Steel
Retainer	Polyamide

Item Code	Item Name	Slide Length	Travel Length	A	B	C	D	Load Capacity(pair)	Weight	
190-116-312	CBL-ST448-300	300	313	285	—	100	—	785N	80kgf	1.05kg
190-116-314	CBL-ST448-400	400	413	385	—	200	—	736N	75kgf	1.4kg
190-116-316	CBL-ST448-500	500	513	485	—	300	—	687N	70kgf	1.75kg
190-116-318	CBL-ST448-600	600	613	—	292.5	—	175	588N	60kgf	2.1kg
190-116-320	CBL-ST448-700	700	713	—	342.5	—	225	490N	50kgf	2.45kg
190-116-321	CBL-ST448-800	800	813	—	392.5	—	275	392N	40kgf	2.8kg

# ULTRA OVER EXTENSION SLIDE

LOAD CAPACITY  
30~45 kgf

NO SCREW

STAINLESS  
304  
STEEL

# CBL-ST658

- Ultra over travel.
- Positive stop.

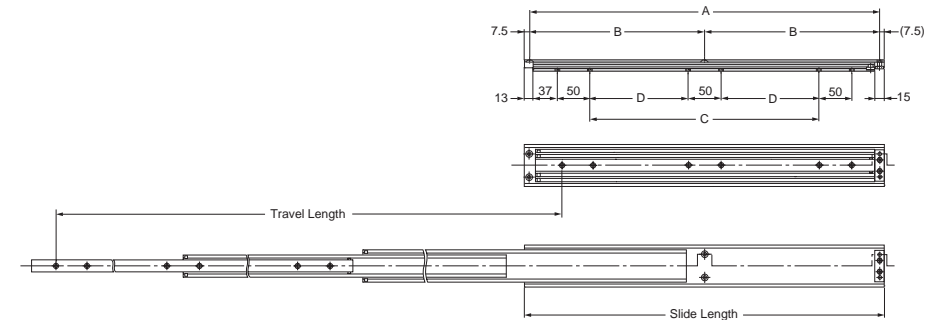
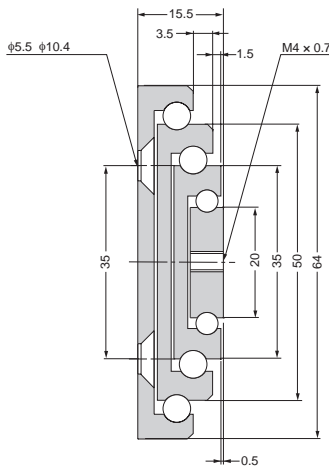

● Lock in open position(optional) ● Lock in closed position(optional)

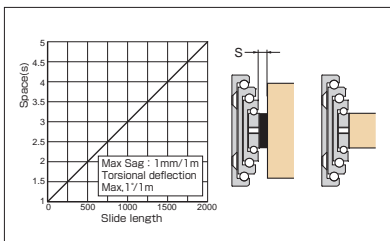
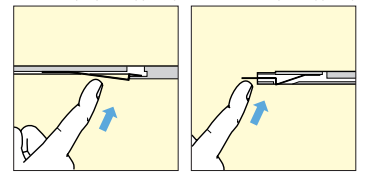

Part Name	Material/Finish
Rail	Stainless Steel(SUS304)
Balls	Stainless Steel
Retainer	Polyamide

Item Code	Item Name	Slide Length	Travel Length	A	B	C	D	Load Capacity(pair)	Weight	
190-116-335	CBL-ST658-300	300	450	285	—	100	—	441N	45kgf	1.65kg
190-116-337	CBL-ST658-400	400	600	385	—	200	—	392N	40kgf	2.2kg
190-116-339	CBL-ST658-500	500	750	485	—	300	—	343N	35kgf	2.75kg
190-116-341	CBL-ST658-600	600	900	—	292.5	—	175	294N	30kgf	3.3kg



# FULL EXTENSION SLIDE

LOAD CAPACITY  
600-1250 kgf



# CBL-E1020

- Full extension.
- Positive stop.

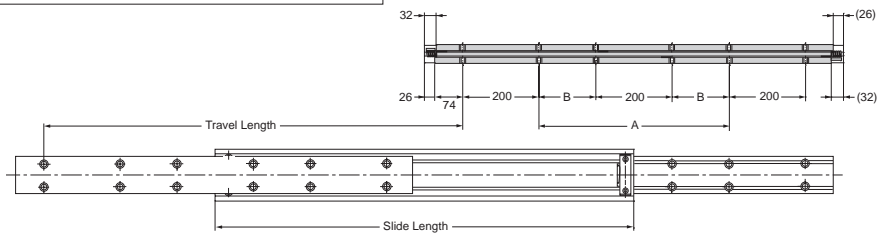
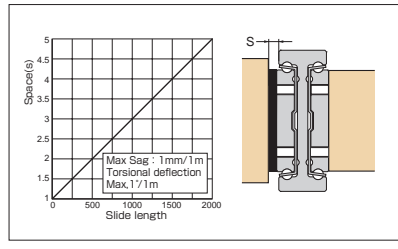
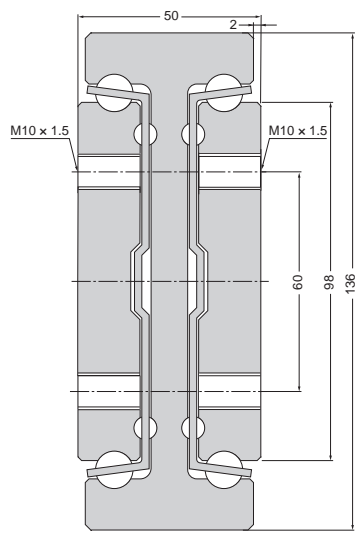

Part Name	Material/Finish
Rail	Steel/Clear zinc chromate
Balls	Chrome
Retainer	Steel

Item Code	Item Name	Slide Length	Travel Length	A	B	Load Capacity(pair)	Weight
190-114-225	CBL-E1020-800	800	800	200	—	12258N 1250kgf	33kg
190-114-227	CBL-E1020-900	900	900	300	—	11278N 1150kgf	37.125kg
190-114-229	CBL-E1020-1000	1000	1000	400	—	10787N 1100kgf	41.25kg
190-114-230	CBL-E1020-1100	1100	1100	—	150	10297N 1050kgf	45.375kg
190-114-231	CBL-E1020-1200	1200	1200	—	200	9807N 1000kgf	49.5kg
190-114-232	CBL-E1020-1300	1300	1300	—	250	9316N 950kgf	53.625kg
190-114-233	CBL-E1020-1400	1400	1400	—	300	8826N 900kgf	57.75kg
190-114-234	CBL-E1020-1500	1500	1500	—	350	8336N 850kgf	61.875kg
190-114-235	CBL-E1020-1600	1600	1600	—	400	7845N 800kgf	66kg
190-114-236	CBL-E1020-1700	1700	1700	—	450	7355N 750kgf	70.125kg
190-114-237	CBL-E1020-1800	1800	1800	—	500	6865N 700kgf	74.25kg
190-114-238	CBL-E1020-1900	1900	1900	—	550	6374N 650kgf	78.375kg
190-114-239	CBL-E1020-2000	2000	2000	—	600	5884N 600kgf	82.5kg

# FULL EXTENTION SLIDE

LOAD CAPACITY  
300-1000 kgf



# CBL-E1012

- Full extention.
- Super heavy duty.

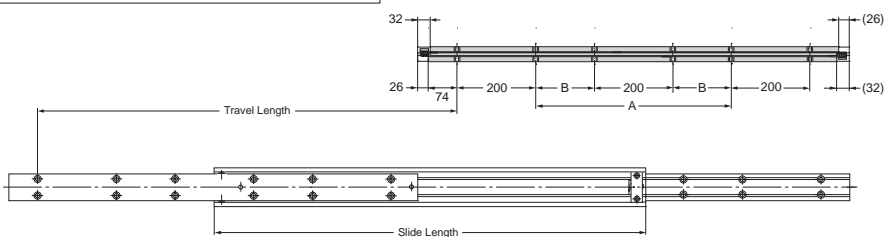
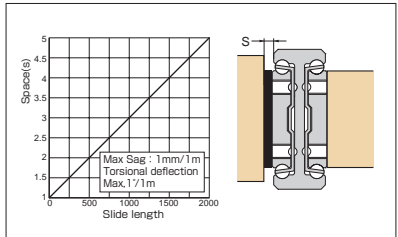
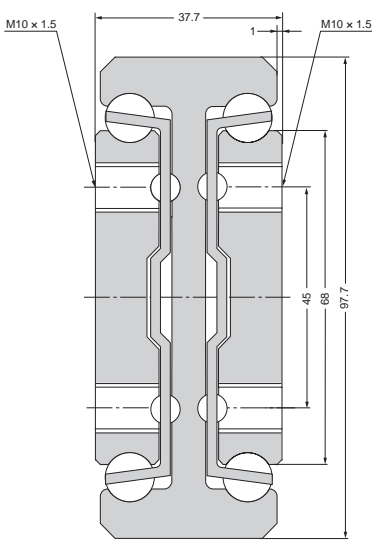

Part Name	Material/Finish
Rail	Steel/Clear zinc chromate
Balls	Chrome
Retainer	Steel, Polyamide

Item Code	Item Name	Slide Length	Travel Length	A	B	Load Capacity(pair)	Weight
190-114-210	CBL-E1012-800	800	800	200	—	9807N 1000kgf	18kg
190-114-212	CBL-E1012-900	900	900	300	—	8826N 900kgf	20.25kg
190-114-214	CBL-E1012-1000	1000	1000	400	—	8336N 850kgf	22.5kg
190-114-215	CBL-E1012-1100	1100	1100	—	150	7845N 800kgf	24.75kg
190-114-216	CBL-E1012-1200	1200	1200	—	200	7355N 750kgf	27kg
190-114-217	CBL-E1012-1300	1300	1300	—	250	6865N 700kgf	29.25kg
190-114-218	CBL-E1012-1400	1400	1400	—	300	5884N 600kgf	31.5kg
190-114-219	CBL-E1012-1500	1500	1500	—	350	5394N 550kgf	33.75kg
190-114-220	CBL-E1012-1600	1600	1600	—	400	4903N 500kgf	36kg
190-114-221	CBL-E1012-1700	1700	1700	—	450	4413N 450kgf	38.25kg
190-114-222	CBL-E1012-1800	1800	1800	—	500	3923N 400kgf	40.5kg
190-114-223	CBL-E1012-1900	1900	1900	—	550	3432N 350kgf	42.75kg
190-114-224	CBL-E1012-2000	2000	2000	—	600	2942N 300kgf	45kg



# FULL EXTENSION SLIDE

LOAD CAPACITY  
250-950 kgf



# CBL-E1902

- Full extension.
- Positive stop.

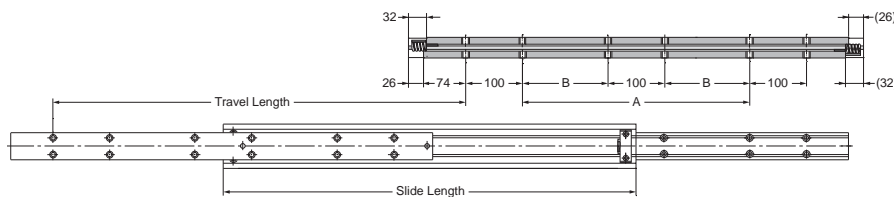
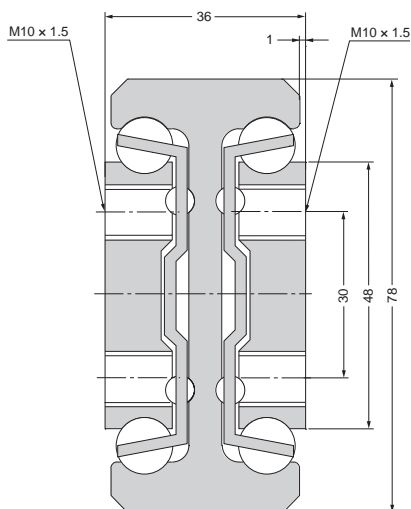

Part Name	Material/Finish
Rail	Steel/Clear zinc chromate
Balls	Chrome
Retainer	Steel, Polyamide

Item Code	Item Name	Slide Length	Travel Length	A	B	Load Capacity(pair)	Weight	
190-114-188	CBL-E1902-500	500	500	100	—	8826N	900kgf	8kg
190-114-190	CBL-E1902-600	600	600	200	—	9316N	950kgf	9.6kg
190-114-192	CBL-E1902-700	700	700	300	—	8826N	900kgf	11.2kg
190-114-194	CBL-E1902-800	800	800	—	150	8336N	850kgf	12.8kg
190-114-196	CBL-E1902-900	900	900	—	200	7845N	800kgf	14.4kg
190-114-198	CBL-E1902-1000	1000	1000	—	250	7355N	750kgf	16kg
190-114-199	CBL-E1902-1100	1100	1100	—	300	6865N	700kgf	17.6kg
190-114-200	CBL-E1902-1200	1200	1200	—	350	6374N	650kgf	19.2kg
190-114-201	CBL-E1902-1300	1300	1300	—	400	5884N	600kgf	20.8kg
190-114-202	CBL-E1902-1400	1400	1400	—	450	5394N	550kgf	22.4kg
190-114-203	CBL-E1902-1500	1500	1500	—	500	4903N	500kgf	24kg
190-114-205	CBL-E1902-1700	1700	1700	—	600	3923N	400kgf	27.2kg
190-114-206	CBL-E1902-1800	1800	1800	—	650	3432N	350kgf	28.8kg
190-114-207	CBL-E1902-1900	1900	1900	—	700	2942N	300kgf	30.4kg
190-114-208	CBL-E1902-2000	2000	2000	—	750	2452N	250kgf	32kg

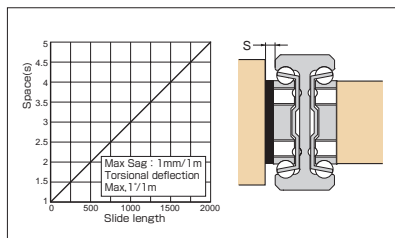

# FULL EXTENSION SLIDE

LOAD CAPACITY  
290-565 kgf



# CBL-E1700

- Full extension.
- Positive stop.

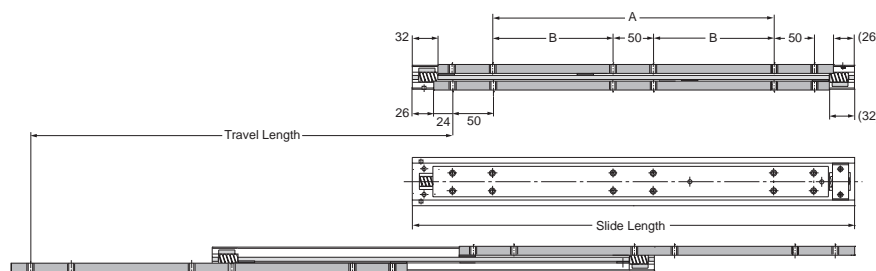
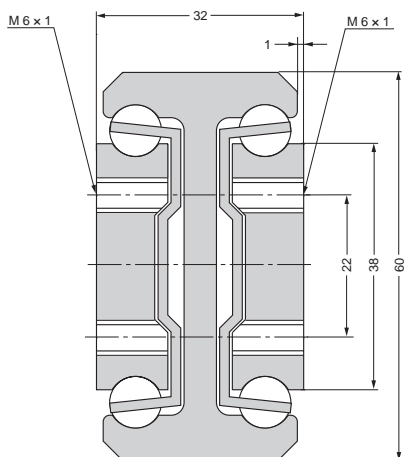

Part Name	Material/Finish
Rail	Steel/Clear zinc chromate
Balls	Chrome
Retainer	Steel

Item Code	Item Name	Slide Length	Travel Length	A	B	Load Capacity(pair)	Weight	
190-114-173	CBL-E1700-500	500	500	300	—	5394N	550kgf	5.5kg
190-114-175	CBL-E1700-600	600	600	—	175	5541N	565kgf	6.6kg
190-114-177	CBL-E1700-700	700	700	—	225	5247N	535kgf	7.7kg
190-114-179	CBL-E1700-800	800	800	—	275	4903N	500kgf	8.8kg
190-114-181	CBL-E1700-900	900	900	—	325	4560N	465kgf	9.9kg
190-114-183	CBL-E1700-1000	1000	1000	—	375	4217N	430kgf	11kg
190-114-184	CBL-E1700-1100	1100	1100	—	425	3874N	395kgf	12.1kg
190-114-185	CBL-E1700-1200	1200	1200	—	475	3530N	360kgf	13.2kg
190-114-186	CBL-E1700-1300	1300	1300	—	525	3187N	325kgf	14.3kg
190-114-187	CBL-E1700-1400	1400	1400	—	575	2844N	290kgf	15.4kg

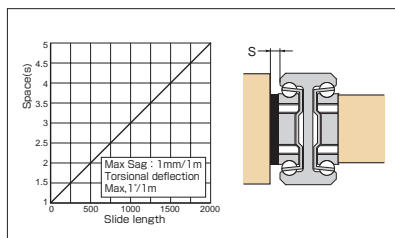



# ULTRA OVER EXTENSION SLIDE



# CBL-E1014

- Ultra over travel.
- Positive stop.

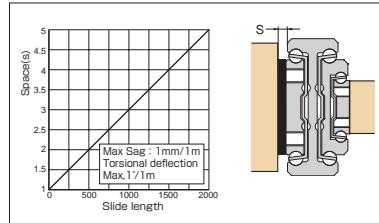
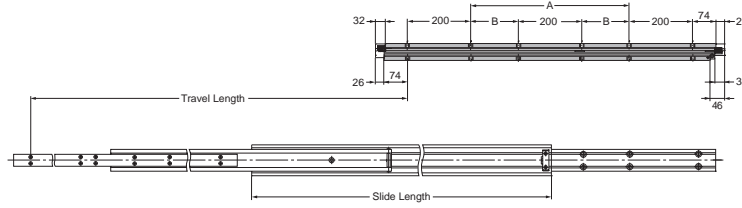
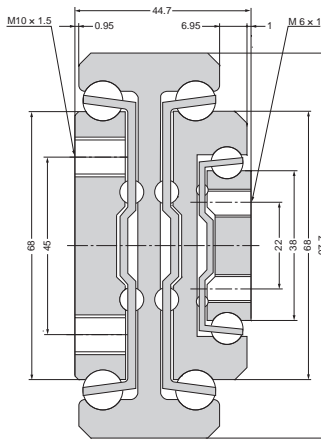

Part Name	Material/Finish
Rail	Steel/Clear zinc chromate
Balls	Chrome
Retainer	Steel, Polyamide

Item Code	Item Name	Slide Length	Travel Length	A	B	Load Capacity(pair)		Weight(pc)
190-114-285	CBL-E1014-800	800	1200	200	—	4903N	500kgf	20kg
190-114-287	CBL-E1014-900	900	1350	300	—	4413N	450kgf	22.5kg
190-114-289	CBL-E1014-1000	1000	1500	400	—	3923N	400kgf	25kg
190-114-290	CBL-E1014-1100	1100	1650	—	150	3678N	375kgf	27.5kg
190-114-291	CBL-E1014-1200	1200	1800	—	200	3432N	350kgf	30kg
190-114-292	CBL-E1014-1300	1300	1950	—	250	3187N	325kgf	32.5kg
190-114-293	CBL-E1014-1400	1400	2100	—	300	2942N	300kgf	35kg
190-114-294	CBL-E1014-1500	1500	2250	—	350	2697N	275kgf	37.5kg
190-114-295	CBL-E1014-1600	1600	2400	—	400	2452N	250kgf	40kg
190-114-296	CBL-E1014-1700	1700	2550	—	450	2207N	225kgf	42.5kg
190-114-297	CBL-E1014-1800	1800	2700	—	500	1961N	200kgf	45kg
190-114-298	CBL-E1014-1900	1900	2850	—	550	1716N	175kgf	47.5kg
190-114-299	CBL-E1014-2000	2000	3000	—	600	1471N	150kgf	50kg

# FULL EXTENSION SLIDE



# CBL-RA7R

- 15mm over travel.
- Positive stop.
- Options: Positive lock.  
Positive catch.  
Two way travel.  
(Maximum slide length 1000mm.)

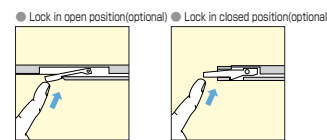
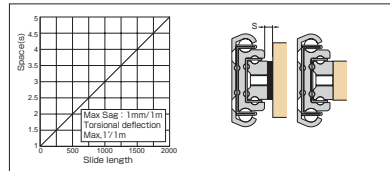
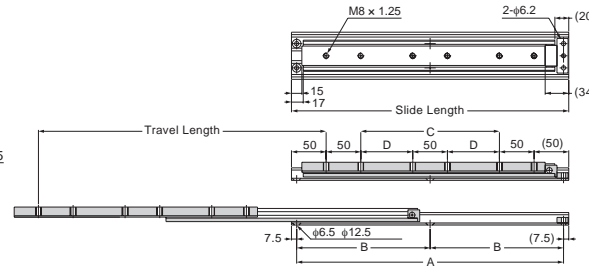
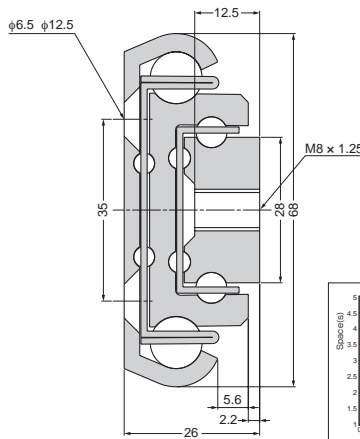

Part Name	Material/Finish
Rail	Steel/ Clear zinc chromate
Balls	Chrome
Retainer	Steel
End stopper	Polyurethane

Item Code	Item Name	Slide Length	Travel Length	A	B	C	D	Load Capacity(pair)		Weight(pc)
190-114-142	CBL-RA7R-300	300	315	285	—	100	—	3334N	340kgf	2.4kg
190-114-144	CBL-RA7R-400	400	415	385	—	200	—	3236N	330kgf	3.6kg
190-114-146	CBL-RA7R-500	500	515	485	—	300	—	3138N	320kgf	4kg
190-114-148	CBL-RA7R-600	600	615	—	292.5	—	175	2942N	300kgf	4.8kg
190-114-150	CBL-RA7R-700	700	715	—	342.5	—	225	2844N	290kgf	5.6kg
190-114-152	CBL-RA7R-800	800	815	—	392.5	—	275	2648N	270kgf	6.4kg
190-114-154	CBL-RA7R-900	900	915	—	442.5	—	325	2452N	250kgf	7.2kg
190-114-156	CBL-RA7R-1000	1000	1015	—	492.5	—	375	2256N	230kgf	8kg
190-114-157	CBL-RA7R-1100	1100	1115	—	542.5	—	425	2059N	210kgf	8.8kg
190-114-158	CBL-RA7R-1200	1200	1215	—	592.5	—	475	1863N	190kgf	9.6kg
190-114-159	CBL-RA7R-1300	1300	1315	—	642.5	—	525	1667N	170kgf	10.4kg
190-114-160	CBL-RA7R-1400	1400	1415	—	692.5	—	575	1471N	150kgf	11.2kg
190-114-161	CBL-RA7R-1500	1500	1515	—	742.5	—	625	1275N	130kgf	12kg



3/4 EXTENSION SLIDE



CBL-R71

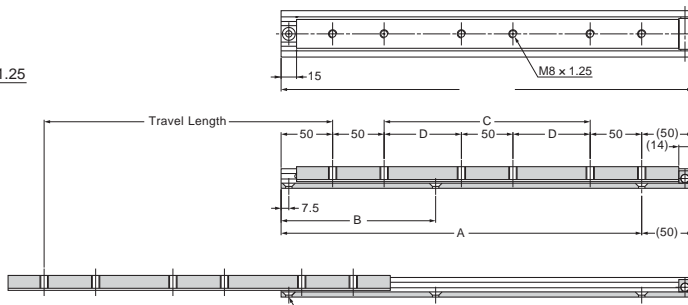
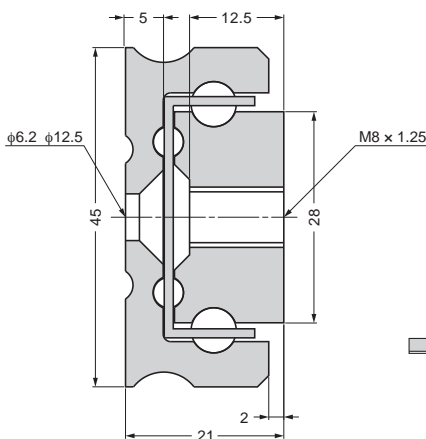

- 3/4 extension.
- Positive stop.
- Options: Positive lock. Positive catch. Two way travel.

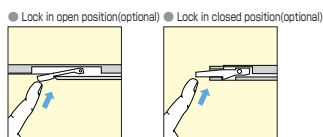

Part Name	Material/Finish
Rail	Steel/Clear zinc chromate
Balls	Chrome
Retainer	Steel
End stopper	Polyurethane

Item Code	Item Name	Slide Length	Travel Length	A	B	C	D	Load Capacity(pair)	Weight
190-114-073	CBL-R71-300	300	180	250	—	100	—	3040N 310kgf	1.62kg
190-114-075	CBL-R71-400	400	280	350	150	200	—	2844N 290kgf	2.16kg
190-114-077	CBL-R71-500	500	340	450	200	300	—	2648N 270kgf	2.7kg
190-114-079	CBL-R71-600	600	400	550	250	—	175	2452N 250kgf	3.24kg
190-114-081	CBL-R71-700	700	480	650	300	—	225	2256N 230kgf	3.78kg
190-114-083	CBL-R71-800	800	540	750	350	—	275	2059N 210kgf	4.32kg
190-114-085	CBL-R71-900	900	600	850	400	—	325	1863N 190kgf	4.86kg
190-114-087	CBL-R71-1000	1000	680	950	450	—	375	1667N 170kgf	5.4kg

ULTRA OVER EXTENSION SLIDE



CBL-E1904

- Ultra Over travel.
- Positive stop.

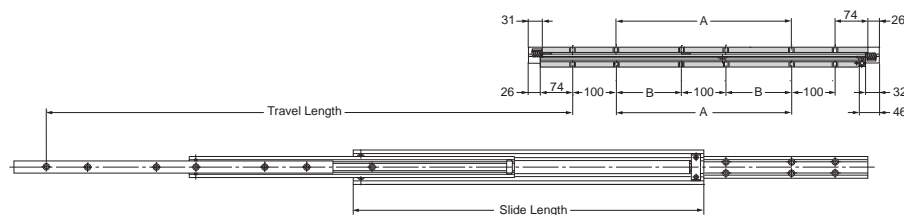
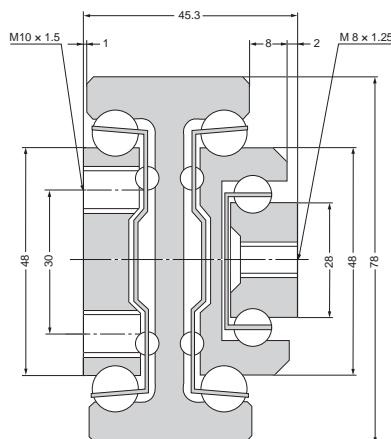

Part Name	Material/Finish
Rail	Steel/Clear zinc chromate
Balls	Chrome
Retainer	Steel, Polyamide

Item Code	Item Name	Slide Length	Travel Length	A	B	Load Capacity(pair)	Weight
190-114-269	CBL-E1904-500	500	760	100	—	2158N 220kgf	8.75kg
190-114-271	CBL-E1904-600	600	900	200	—	1961N 200kgf	10.5kg
190-114-273	CBL-E1904-700	700	1060	300	—	1863N 190kgf	12.25kg
190-114-275	CBL-E1904-800	800	1200	—	150	1667N 170kgf	14kg
190-114-277	CBL-E1904-900	900	1360	—	200	1569N 160kgf	15.75kg
190-114-279	CBL-E1904-1000	1000	1500	—	250	1471N 150kgf	17.5kg
190-114-280	CBL-E1904-1100	1100	1660	—	300	1324N 135kgf	19.25kg
190-114-281	CBL-E1904-1200	1200	1800	—	350	1177N 120kgf	21kg
190-114-282	CBL-E1904-1300	1300	1960	—	400	1030N 105kgf	22.75kg
190-114-283	CBL-E1904-1400	1400	2100	—	450	883N 90kgf	24.5kg
190-114-284	CBL-E1904-1500	1500	2260	—	500	785N 80kgf	26.25kg

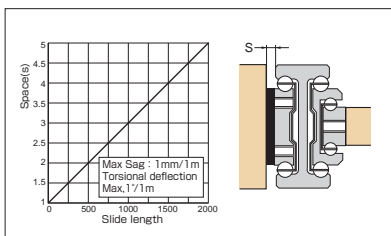

# FULL EXTENSION SLIDE



# CBL-RA5R

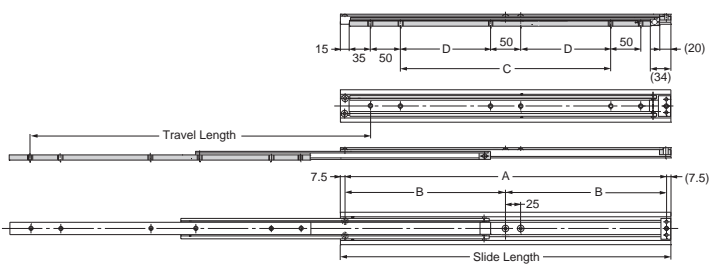
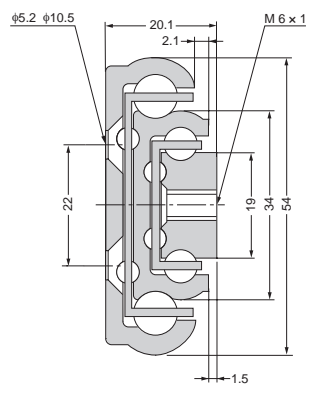

- 15mm (19/32") over travel.
- Positive stop.
- Options: Positive lock.  
Positive catch.  
Two way travel.

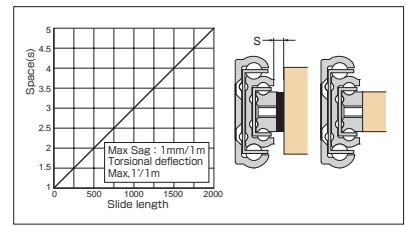
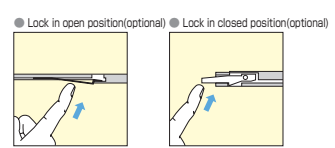

Part name	Material/Finish
Rail	Steel/Clear zinc chromate
Balls	Chrome
Retainer	Steel
End stopper	Polyurethane

Item Code	Item Name	Slide Length	Travel Length	A	B	C	D	Load Capacity(pair)	Weight(pc)	
190-114-125	CBL-RA5R-300	300	315	285	—	100	—	1471N	150kgf	1.35kg
190-114-127	CBL-RA5R-400	400	415	385	—	200	—	1373N	140kgf	1.8kg
190-114-129	CBL-RA5R-500	500	515	485	—	300	—	1275N	130kgf	2.25kg
190-114-131	CBL-RA5R-600	600	615	—	292.5	—	175	1177N	120kgf	2.7kg
190-114-133	CBL-RA5R-700	700	715	—	342.5	—	225	1079N	110kgf	3.15kg
190-114-135	CBL-RA5R-800	800	815	—	392.5	—	275	981N	100kgf	3.6kg
190-114-137	CBL-RA5R-900	900	915	—	442.5	—	325	883N	90kgf	4.05kg
190-114-139	CBL-RA5R-1000	1000	1015	—	492.5	—	375	785N	80kgf	4.5kg
190-114-140	CBL-RA5R-1100	1100	1115	—	542.5	—	425	687N	70kgf	4.95kg
190-114-141	CBL-RA5R-1200	1200	1215	—	592.5	—	475	588N	60kgf	5.4kg

# 3/4 EXTENSION SLIDE

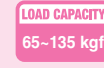

# CBL-R53

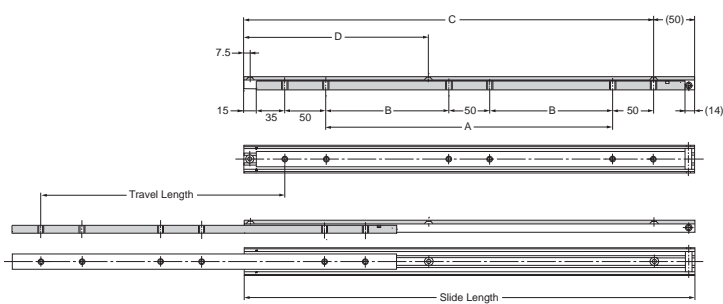
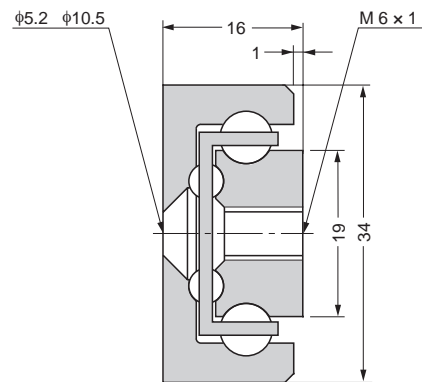

- 3/4 extension.
- Positive stop.
- Options: Two way travel.  
Positive catch.  
Positive lock.

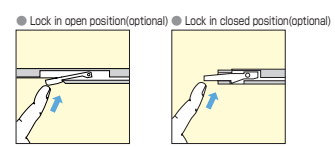

Part name	Material/Finish
Rail	Steel/Clear zinc chromate
Balls	Chrome
Retainer	Steel
End stopper	Polyurethane

Item Code	Item Name	Slide Length	Travel Length	A	B	C	D	Load Capacity(pair)	Weight(pc)	
190-114-057	CBL-R53-300	300	180	100	—	250	—	1324N	135kgf	0.87kg
190-114-059	CBL-R53-400	400	280	200	—	350	150	1226N	125kgf	1.16kg
190-114-061	CBL-R53-500	500	340	300	—	450	200	1128N	115kgf	1.45kg
190-114-063	CBL-R53-600	600	400	—	175	550	250	1030N	105kgf	1.74kg
190-114-065	CBL-R53-700	700	480	—	225	650	300	932N	95kgf	2.03kg
190-114-067	CBL-R53-800	800	540	—	275	750	350	834N	85kgf	2.32kg
190-114-069	CBL-R53-900	900	600	—	325	850	400	736N	75kgf	2.61kg
190-114-071	CBL-R53-1000	1000	680	—	375	950	450	637N	65kgf	2.9kg

# FULL EXTENSION SLIDE



# CBL-E1400

- Full extension.
- Positive stop.

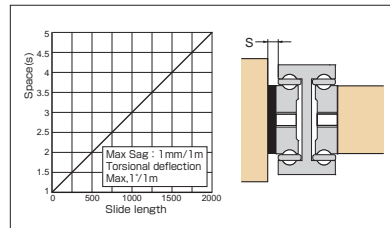
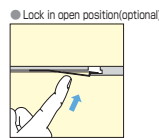
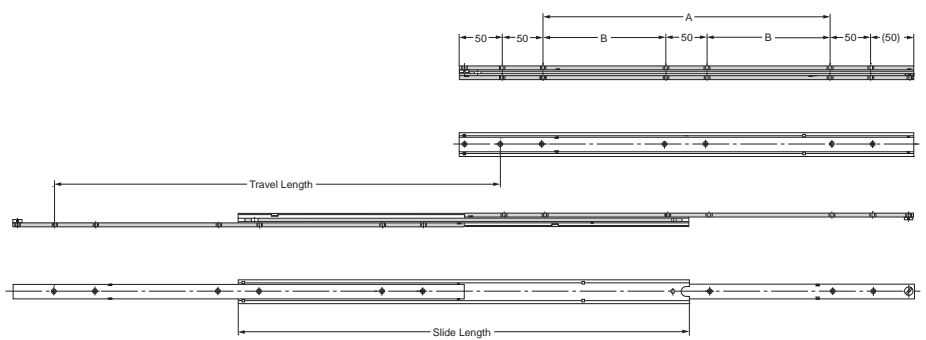
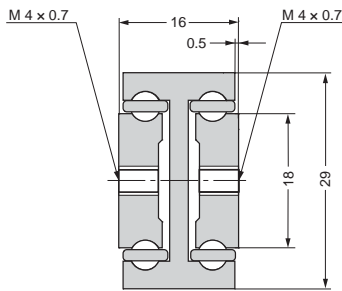

Part Name	Material/Finish
Rail	Steel/Clear zinc chromate
Balls	Chrome
Retainer	Polyamide

Item Code	Item Name	Slide Length	Travel Length	A	B	Load Capacity(pair)	Weight(pc)
190-114-163	CBL-E1400-300	300	300	100	—	1275N / 130kgf	0.9kg
190-114-165	CBL-E1400-400	400	400	200	—	1177N / 120kgf	1.2kg
190-114-167	CBL-E1400-500	500	500	300	—	1079N / 110kgf	1.5kg
190-114-169	CBL-E1400-600	600	600	—	175	981N / 100kgf	1.8kg
190-114-171	CBL-E1400-700	700	700	—	225	883N / 90kgf	2.1kg
190-114-172	CBL-E1400-800	800	800	—	275	785N / 80kgf	2.4kg

# 3/4 EXTENSION SLIDE



# CBL-R26

- 3/4 extension.
- Positive stop.

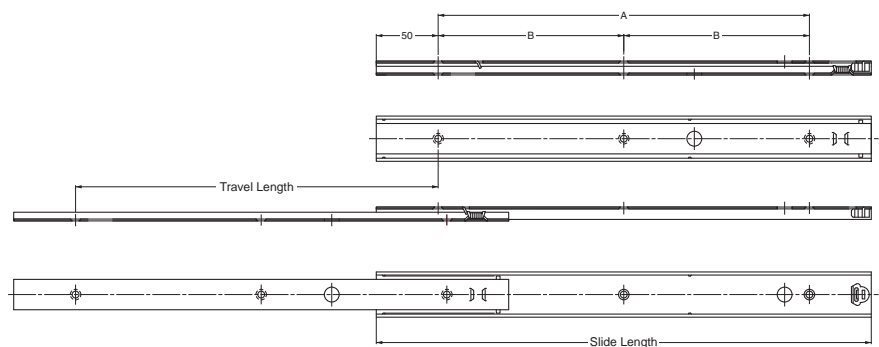
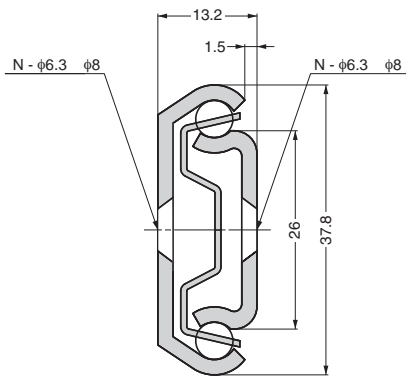

Part Name	Material/Finish
Rail	Steel/Clear zinc chromate
Balls	Steel
Retainer	
End Stopper	Polyurethane (PUR)

Item Code	Item Name	Slide Length	Travel Length	A	B	Number of Holes φ 6.3, φ 8	Load Capacity(pair)	Weight(pc)
190-114-043	CBL-R26-200	200	125	100	—	2pcs	834N / 85kgf	0.28kg
190-114-045	CBL-R26-300	300	225	200	—	3pcs	932N / 95kgf	0.42kg
190-114-047	CBL-R26-400	400	295	—	150	5pcs	834N / 85kgf	0.56kg
190-114-049	CBL-R26-500	500	380	—	200	5pcs	736N / 75kgf	0.7kg
190-114-051	CBL-R26-600	600	450	—	250	5pcs	637N / 65kgf	0.84kg
190-114-053	CBL-R26-700	700	520	—	300	5pcs	539N / 55kgf	0.98kg
190-114-055	CBL-R26-800	800	560	—	350	5pcs	441N / 45kgf	1.12kg

# FULL EXTENSION SLIDE



# CBL-RA41

- Full extension.
- Positive stop.

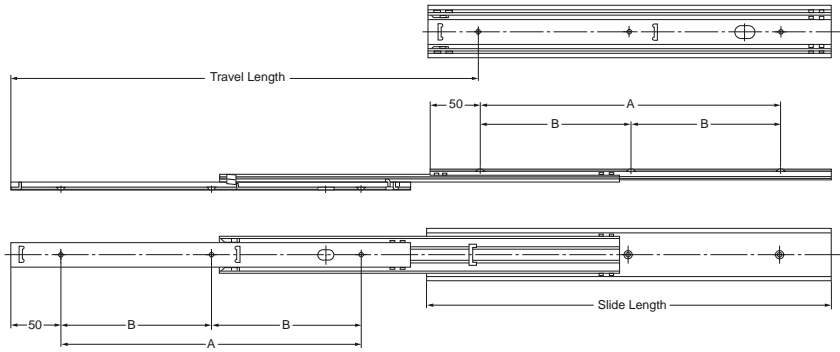
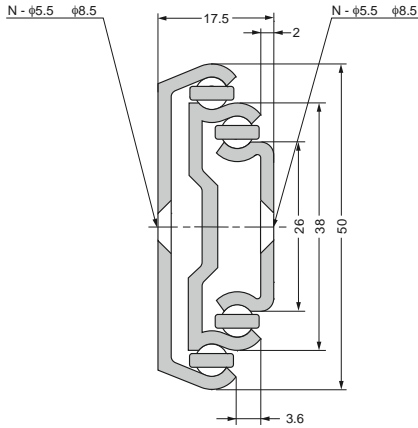

Part Name	Material/Finish
Rail	Steel/ White zinc chromate
Balls	Chrome
Retainer	Polyamide

Item Code	Item Name	Slide Length	Travel Length	A	B	Number of Holes φ 5.5, φ 8.5	Load Capacity (pair)	Weight (pc)
190-114-114	CBL-RA41-300	300	310	200	—	2pcs	932N 95kgf	0.78kg
190-114-116	CBL-RA41-400	400	420	—	150	3pcs	834N 85kgf	1.04kg
190-114-118	CBL-RA41-500	500	515	—	200	3pcs	736N 75kgf	1.3kg
190-114-120	CBL-RA41-600	600	610	—	250	3pcs	637N 65kgf	1.56kg
190-114-122	CBL-RA41-700	700	720	—	300	3pcs	539N 55kgf	1.82kg
190-114-124	CBL-RA41-800	800	815	—	350	3pcs	441N 45kgf	2.08kg

# ULTRA OVER EXTENSION SLIDE



# CBL-RA554R

- Ultra over travel.
- Positive stop.
- Options: Positive lock.  
Positive catch.

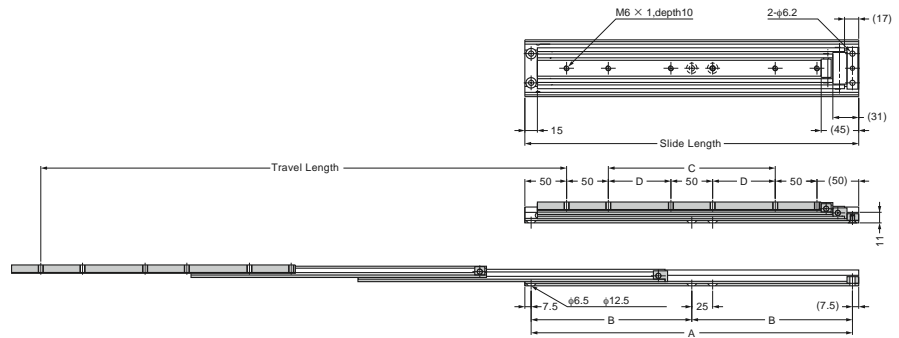
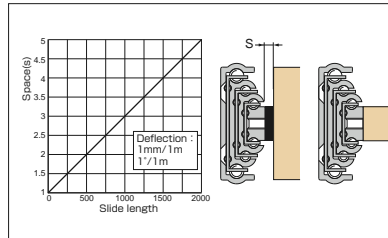
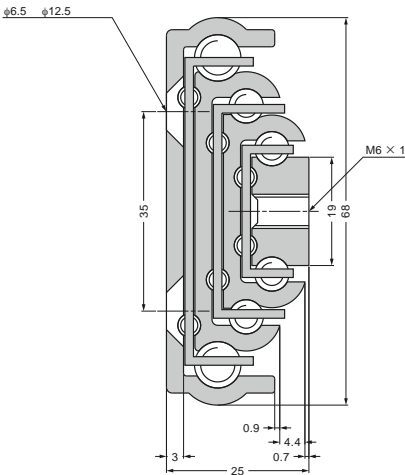
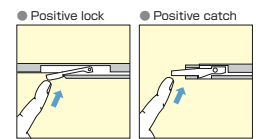

Part Name	Material/Finish
Rail	Steel/ White zinc chromate
Balls	Chrome
Retainer	Steel/ White zinc chromate
End stopper	Polyurethane

Item Code	Item Name	Slide Length	Travel Length	A	B	C	D	Load Capacity(pair)	Weight
190-114-258	CBL-RA554R-300	300	470	285	—	100	—	834N 85kgf	1.8kg
190-114-260	CBL-RA554R-400	400	630	385	—	200	—	932N 95kgf	2.4kg
190-114-262	CBL-RA554R-500	500	770	485	—	300	—	834N 85kgf	3.0kg
190-114-264	CBL-RA554R-600	600	930	—	292.5	—	175	736N 75kgf	3.6kg
190-114-266	CBL-RA554R-700	700	1070	—	342.5	—	225	637N 65kgf	4.2kg
190-114-268	CBL-RA554R-800	800	1230	—	392.5	—	275	539N 55kgf	4.8kg

# FULL EXTENSION SLIDE

LOAD CAPACITY  
35~65 kgf



# CBL-RT3D

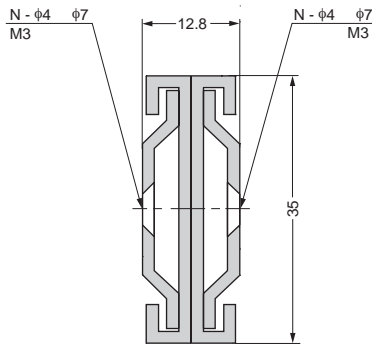

- Full extension.
- Positive stop.
- Inner-rail (b) can be removed by operating (a).

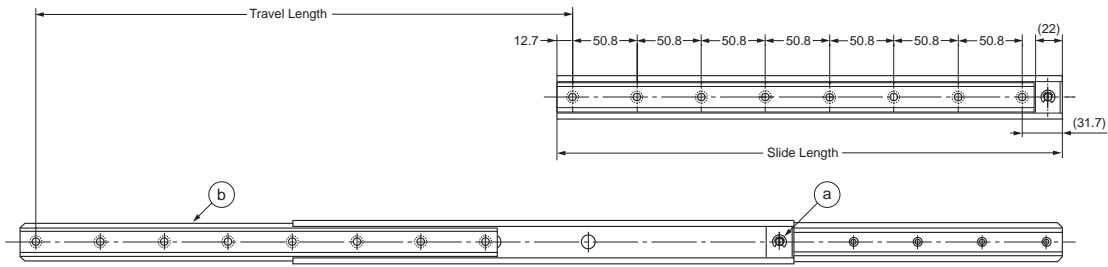

Part Name	Material/Finish
Inner Rail	Steel/ White zinc chromate
Outer Rail	Steel/ Nylon Plastic Coating

Slide length:248~603mm.  
Please contact customer service for details.

# FULL EXTENSION SLIDE



LOAD CAPACITY  
40~80 kgf



# CBL-RA44

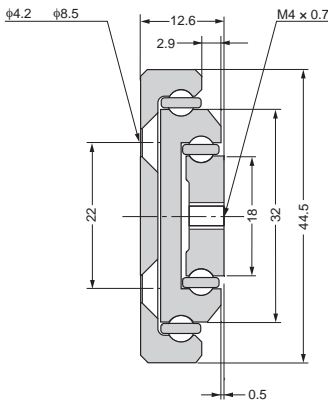

- Full extension.
- Positive stop.
- Options:Positive lock. Positive catch.

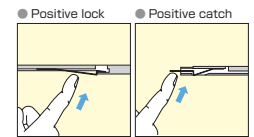
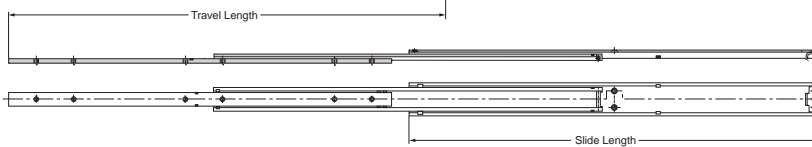
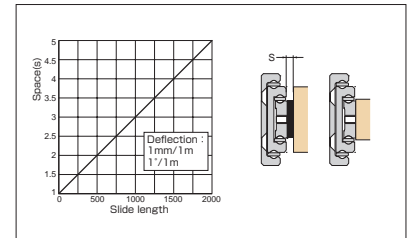
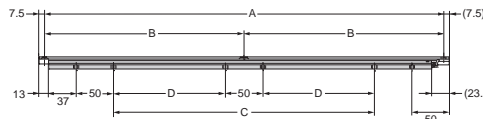

Part Name	Material/Finish
Rail	Steel/ Clear zinc chromate
Balls	Chrome
Retainer	Polyamide

Item Code	Item Name	Slide Length	Travel Length	A	B	C	D	Load Capacity(pair)	Weight(pc)	
190-114-103	CBL-RA44-300	300	313	285	—	100	—	785N	80kgf	1.02kg
190-114-105	CBL-RA44-400	400	413	385	—	200	—	736N	75kgf	1.36kg
190-114-107	CBL-RA44-500	500	513	485	—	300	—	687N	70kgf	1.7kg
190-114-109	CBL-RA44-600	600	613	—	292.5	—	175	588N	60kgf	2.04kg
190-114-111	CBL-RA44-700	700	713	—	342.5	—	225	490N	50kgf	2.38kg
190-114-113	CBL-RA44-800	800	813	—	392.5	—	275	392N	40kgf	2.72kg

# FULL EXTENSION SLIDE



# CBL-RA31

- Full extension.
- Positive stop.

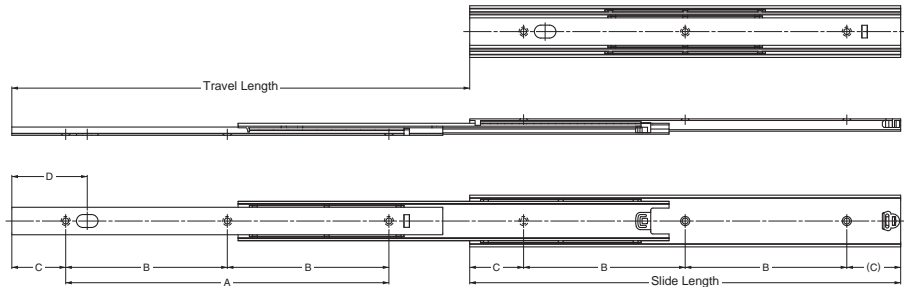
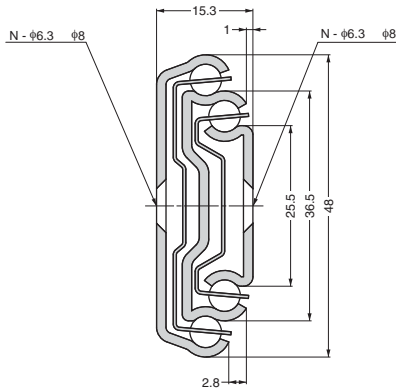

Part Name	Material/Finish	Item Code	Item Name	Slide Length	Travel Length	A	B	C	D	Number of Holes N φ 6.3, φ 8	Load Capacity (pair)	Weight (pc)
Rail	Steel/ White zinc chromate	190-114-089	CBL-RA31-200	200	215	100	—	50	70	2pcs	510N 52kgf	0.38kg
Balls	Steel	190-114-091	CBL-RA31-300	300	310	200	—	50	70	2pcs	539N 55kgf	0.57kg
Retainer	Polyamide	190-114-093	CBL-RA31-400	400	420	—	150	50	70	3pcs	490N 50kgf	0.76kg
End Stopper	Polyurethane (PUR)	190-114-095	CBL-RA31-500	500	515	—	200	50	70	3pcs	441N 45kgf	0.95kg
		190-114-097	CBL-RA31-600	600	610	—	250	50	70	3pcs	392N 40kgf	1.14kg
		190-114-099	CBL-RA31-700	700	720	—	300	50	70	3pcs	343N 35kgf	1.33kg
		190-114-101	CBL-RA31-800	800	815	—	350	50	70	3pcs	294N 30kgf	1.52kg

# ULTRA OVER EXTENSION SLIDE



# CBL-RA654

- Ultra Over travel.
- Positive stop.
- Options: Positive lock. Positive catch.

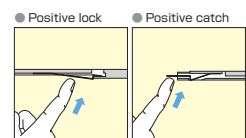
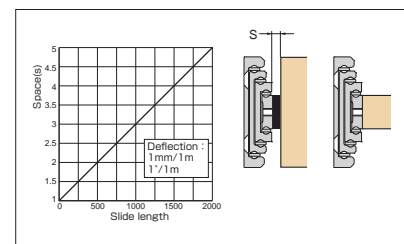
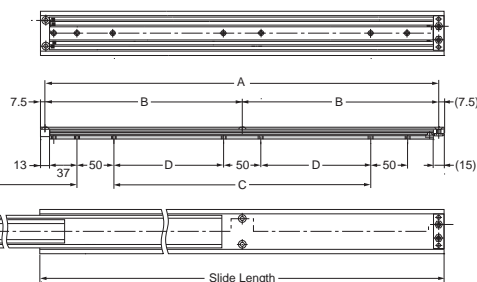
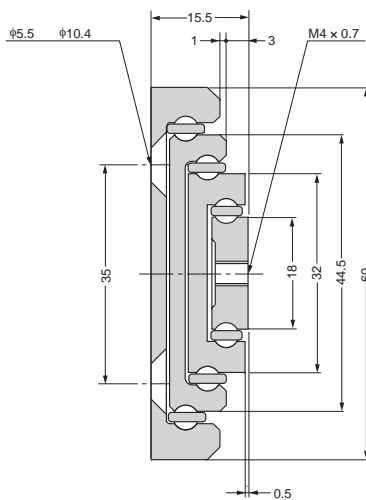

Part Name	Material/Finish	Item Code	Item Name	Slide Length	Travel Length	A	B	C	D	Load Capacity(pair)	Weight(pc)
Rail	Steel/ White zinc chromate	190-114-241	CBL-RA654-300	300	450	285	—	100	—	441N 45kgf	1.65kg
Balls	Chrome	190-114-243	CBL-RA654-400	400	600	385	—	200	—	392N 40kgf	2.2kg
Retainer	Polyamide	190-114-245	CBL-RA654-500	500	750	485	—	300	—	343N 35kgf	2.75kg
		190-114-247	CBL-RA654-600	600	900	—	292.5	—	175	294N 30kgf	3.3kg

### 3/4 EXTENSION SLIDE

LOAD CAPACITY  
10~39 kgf



### CBL-R20

- 3/4 extension.
- Positive stop.

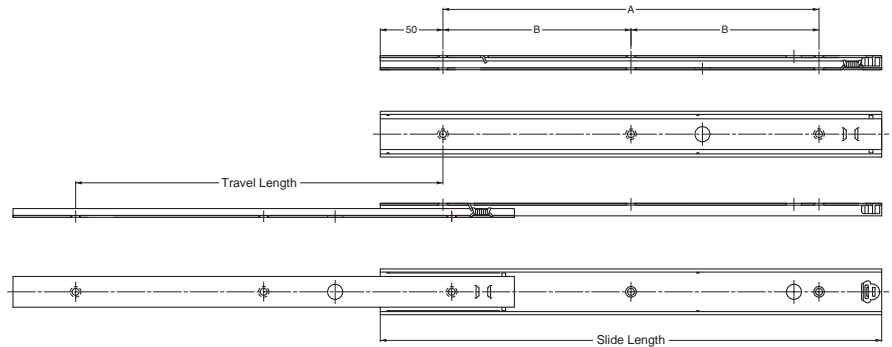
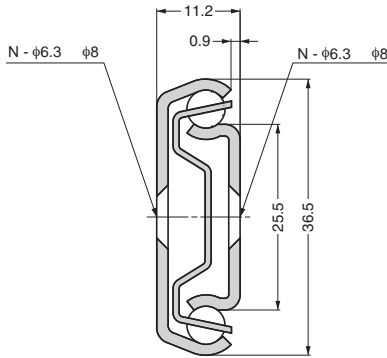

Part Name	Material/Finish
Rail	Steel/ White zinc chromate
Balls	Steel
Retainer	
End Stopper	Polyurethane (PUR)

Item Code	Item Name	Slide Length	Travel Length	A	B	Number of Holes N φ 6.3, φ 8	Load Capacity(pair)	Weight(pc)
190-114-030	CBL-R20-200	200	125	100	—	2pcs	383N 39kgf	0.192kg
190-114-032	CBL-R20-300	300	225	200	—	2pcs	343N 35kgf	0.288kg
190-114-034	CBL-R20-400	400	295	—	150	3pcs	294N 30kgf	0.384kg
190-114-036	CBL-R20-500	500	380	—	200	3pcs	245N 25kgf	0.48kg
190-114-038	CBL-R20-600	600	450	—	250	3pcs	196N 20kgf	0.576kg
190-114-040	CBL-R20-700	700	520	—	300	3pcs	147N 15kgf	0.672kg
190-114-042	CBL-R20-800	800	560	—	350	3pcs	98N 10kgf	0.768kg

### FULL EXTENSION SLIDE

LOAD CAPACITY  
40~80 kgf



### CBL-D500

- Aluminum slide.
- Full extension.
- Positive stop.
- Options: Positive lock. Positive catch. Two way travel.

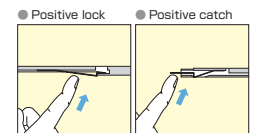
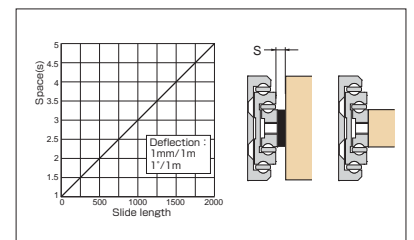
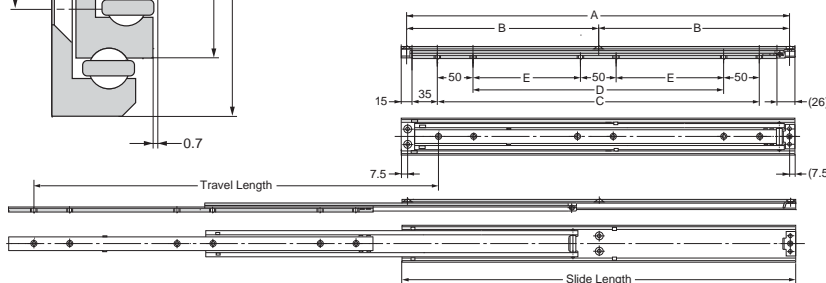
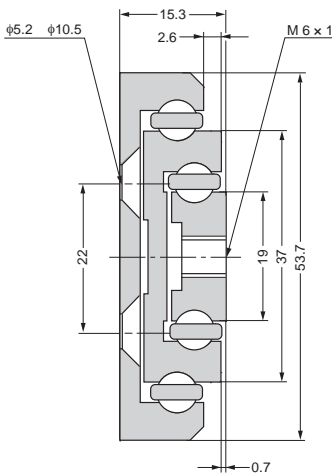

Part Name	Material/Finish
Rail	Aluminum Alloy/ Anodized
Balls	Chrome
Retainer	Polyamide

Item Code	Item Name	Slide Length	Travel Length	A	B	C	D	E	Load Capacity(pair)	Weight(pc)
190-116-670	CBL-D500-200	200	215	185	—	100	—	—	687N 70kgf	0.34kg
190-116-672	CBL-D500-300	300	315	285	—	—	100	—	785N 80kgf	0.51kg
190-116-674	CBL-D500-400	400	415	385	—	—	200	—	736N 75kgf	0.68kg
190-116-676	CBL-D500-500	500	515	485	—	—	300	—	687N 70kgf	0.85kg
190-116-678	CBL-D500-600	600	615	—	292.5	—	—	175	588N 60kgf	1.02kg
190-116-680	CBL-D500-700	700	715	—	342.5	—	—	225	490N 50kgf	1.19kg
190-116-682	CBL-D500-800	800	815	—	392.5	—	—	275	392N 40kgf	1.36kg

# FULL EXTENSION SLIDE

LOAD CAPACITY  
40-50 kgf



# CBL-D444

- Aluminum slide.
- Full extension.
- Positive stop.
- Options: Positive lock. Positive catch.

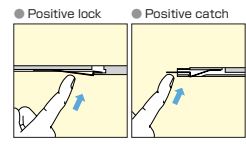
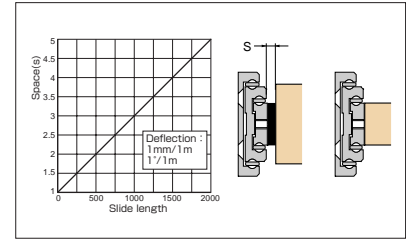
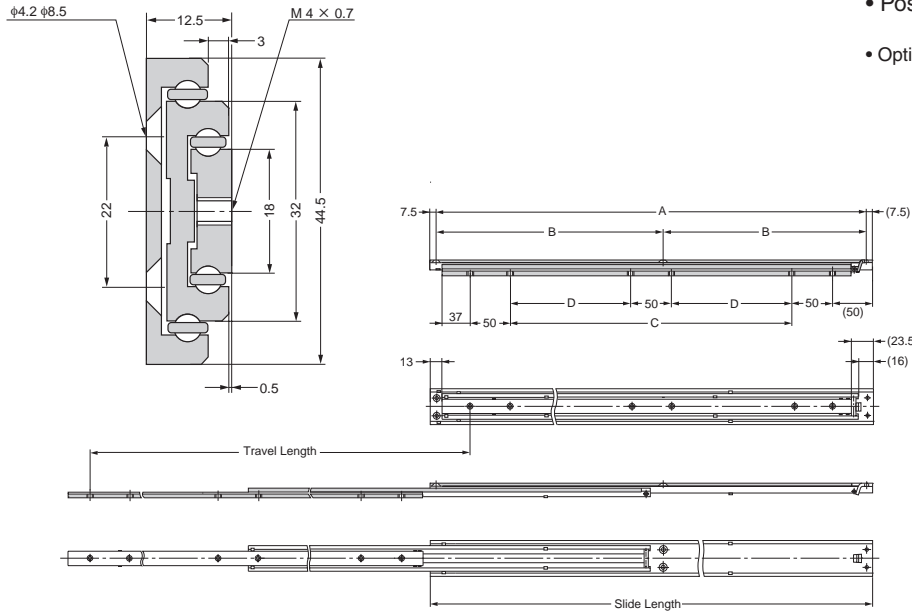

Part Name	Material/Finish
Rail	Aluminum Alloy/ Anodized
Balls	Chrome
Retainer	Polyamide

Item Code	Item Name	Slide Length	Travel Length	A	B	C	D	Load Capacity(pair)	Weight(pc)	
190-116-402	CBL-D444-400	400	413	385	—	200	—	490N	50kgf	0.4kg
190-116-404	CBL-D444-500	500	513	485	—	300	—	441N	45kgf	0.5kg
190-116-406	CBL-D444-600	600	613	—	292.5	—	175	392N	40kgf	0.6kg

# 3/4 EXTENSION SLIDE

LOAD CAPACITY  
15-50 kgf



# CBL-D402

- Aluminum slide.
- 3/4 extension.
- Positive stop.
- Options: Positive lock. Positive catch. Two way travel.

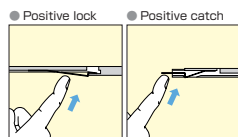
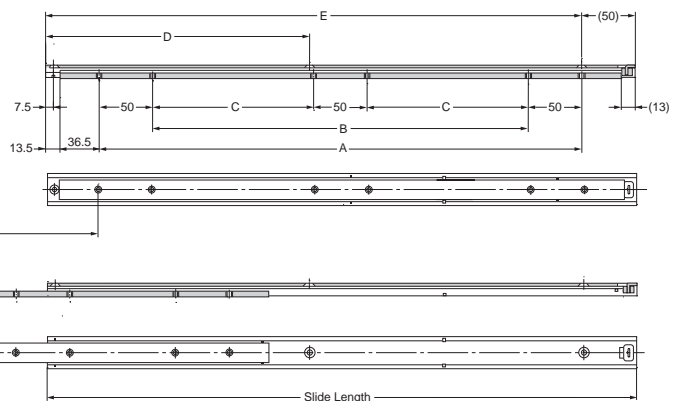
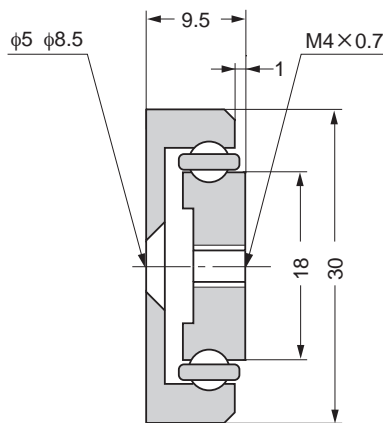

Part Name	Material/Finish
Rail	Aluminum Alloy/ Anodized
Balls	Chrome
Retainer	Polyamide

Item Code	Item Name	Slide Length	Travel Length	A	B	C	D	E	Load Capacity(pair)	Weight(pc)	
190-116-660	CBL-D402-200	200	120	100	—	—	—	150	147N	15kgf	0.1kg
190-116-662	CBL-D402-300	300	180	—	100	—	—	250	490N	50kgf	0.15kg
190-116-664	CBL-D402-400	400	280	—	200	—	150	350	392N	40kgf	0.20kg
190-116-666	CBL-D402-500	500	330	—	300	—	200	450	245N	25kgf	0.25kg
190-116-668	CBL-D402-600	600	400	—	—	175	250	550	147N	15kgf	0.3kg



# STAINLESS STEEL LINEAR BALL

LOAD CAPACITY  
30-100 kgf



# CBL-ST45

- Super heavy duty type.
- Carriage selected from GS55 or GS56.
- End-stopper is sold separately.

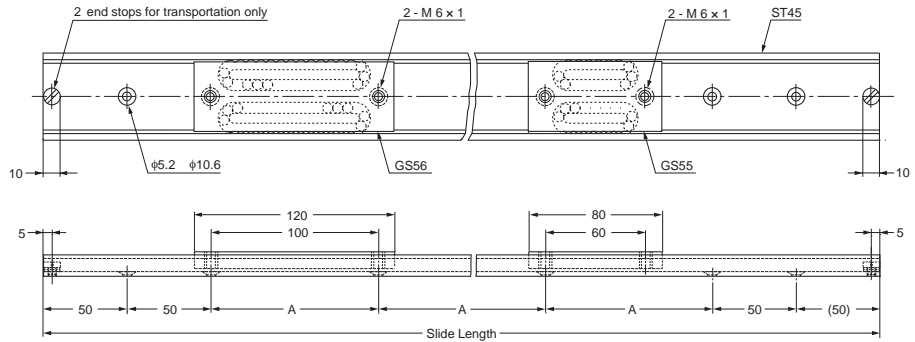
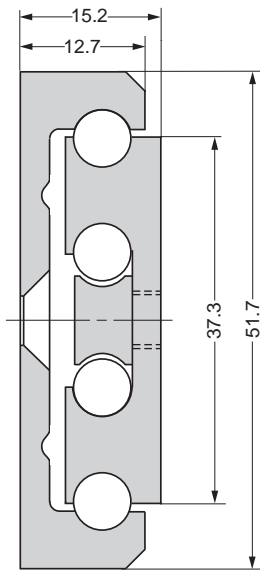

### LINEAR GUIDE

Item Code	Item Name	Material	Finish	Weight
—	CBL-ST45	Stainless Steel(SUS304)	Plain	2kg/m

Length:Please contact customer service for details.

### CARRIER

Item Code	Item Name	Material	Finish	Load Capacity		Weight (pc)	Balls		
—	GS55	Stainless Steel	Plain	588N	60kgf	294N	30kgf	0.16kg	32pcs
—	GS56	(SUS304)		980N	100kgf	588N	60kgf	0.26kg	60pcs

# LINEAR BALL BEARING GUIDE

LOAD CAPACITY  
400-600 kgf



# CBL-E98

- Super heavy duty type.
- End-stopper is sold separately.

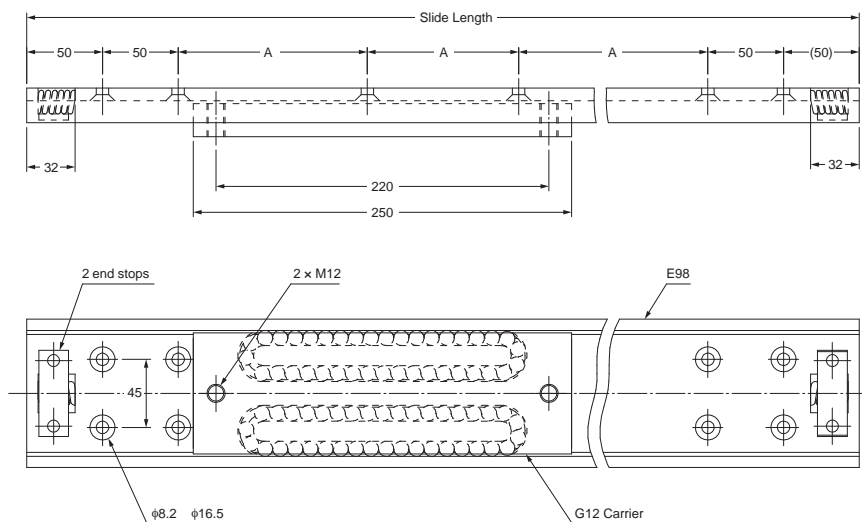
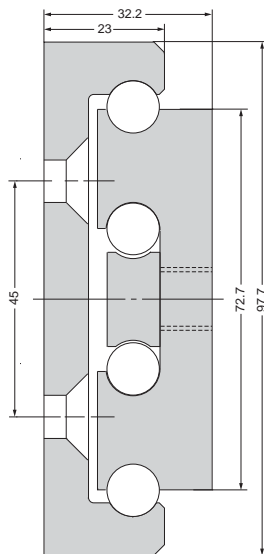

### LINEAR GUIDE

Item Code	Item Name	Material	Finish	Weight
—	CBL-E98	Steel	White Trivalent Chromate	8.6kg/m

Length:Please contact customer service for details.

### CARRIER

Item Code	Item Name	Material	Finish	Load Capacity		Weight (pc)	Balls		
—	G12	Steel	Special surface treatment	5880N	600kgf	3920N	400kgf	2.52kg	76pcs

# LINEAR BALL BEARING GUIDE

LOAD CAPACITY  
125-250 kgf



## CBL-E46

• Carriage selected from G52 or G54.

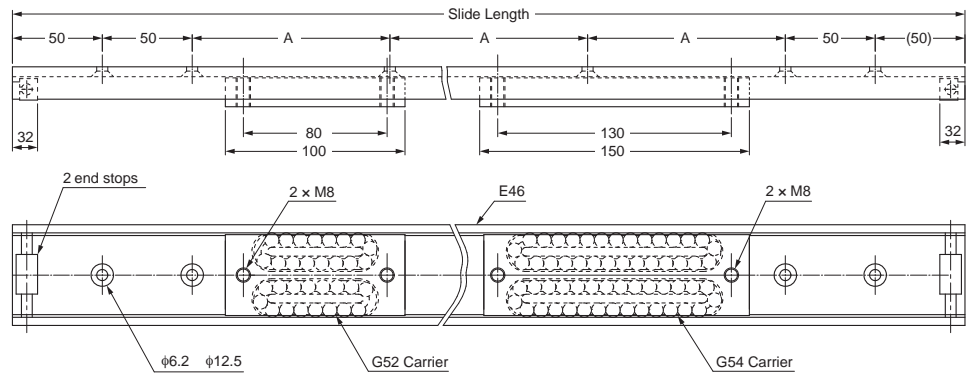
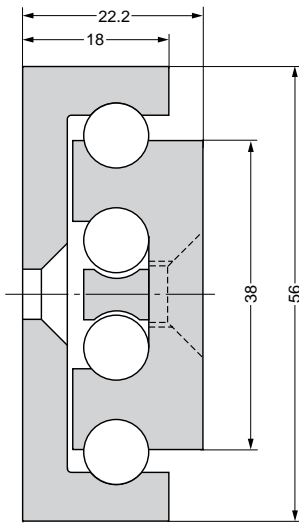

### LINEAR GUIDE

Item Code	Item Name	Material	Finish	Weight
—	CBL-E46	Steel	White Trivalent Chromate	3.5kg/m

Length: Please contact customer service for details.

### CARRIER

Item Code	Item Name	Material	Finish	Load Capacity		Weight	Balls		
—	G52	Steel	Special surface treatment	2450N	250kgf	1225N	125kgf	0.34kg	32pcs
—	G54			3038N	310kgf	1519N	155kgf	0.52kg	32pcs

Special surface treatment...Gaseous Nitro Carburising

# LINEAR BALL BEARING GUIDE

LOAD CAPACITY  
60-160 kgf



## CBL-E72

• Carriage selected from G70 or G72.

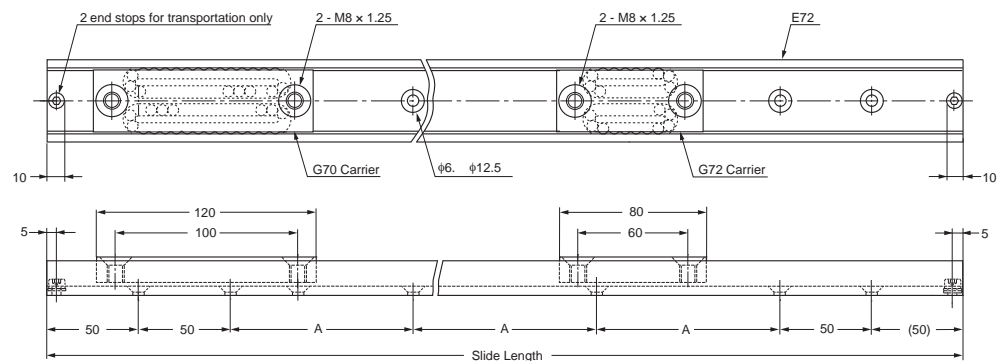
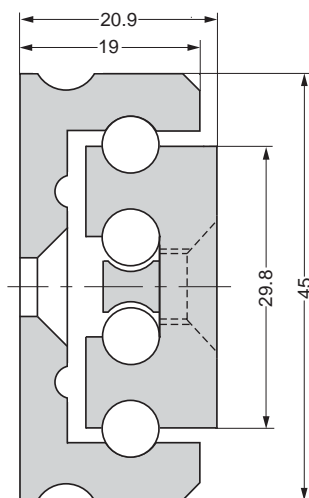

### LINEAR GUIDE

Item Code	Item Name	Material	Finish	Weight
—	CBL-E72	Steel	White Trivalent Chromate	3kg/m

Length: Please contact customer service for details.

### CARRIER

Item Code	Item Name	Material	Finish	Load Capacity		Weight	Balls		
—	G70	Steel	Special surface treatment	1568N	160kgf	784N	80kgf	0.28kg	58pcs
—	G72			1176N	120kgf	588N	60kgf	0.18kg	32pcs

Special surface treatment...Gaseous Nitro Carburising

# LINEAR BALL BEARING GUIDE

LOAD CAPACITY  
90~240 kgf



# CBL-E50

• Carriage selected from G52 or G54.

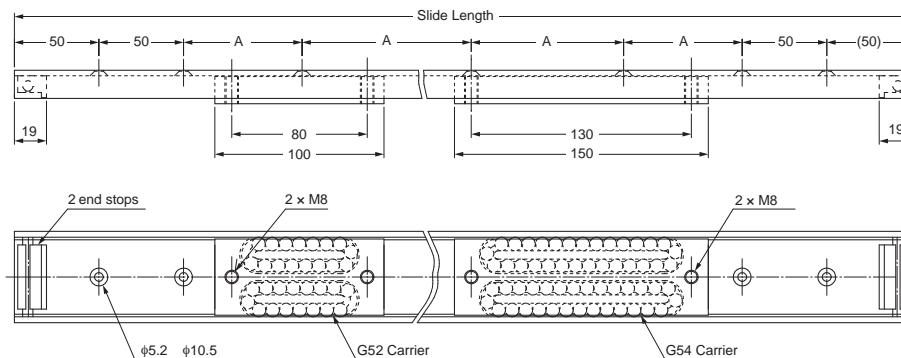
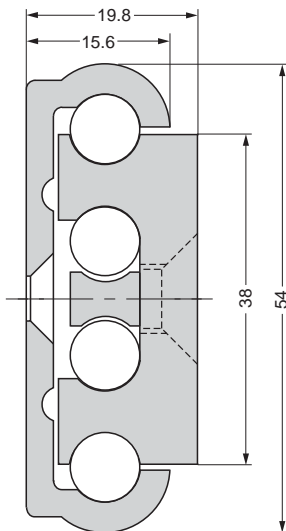

### LINEAR GUIDE

Item Code	Item Name	Material	Finish	Weight
—	CBL-E50	Steel	White Trivalent Chromate	2.05kg/m

Length: Please contact customer service for details.

### CARRIER

Item Code	Item Name	Material	Finish	Load Capacity				Weight	Balls
—	G52	Steel	Special surface treatment	1764N	180kgf	882N	90kgf	0.34kg	32pcs
—	G54			2352N	240kgf	1176N	120kgf	0.52kg	58pcs

Special surface treatment ··· Gaseous Nitro Carburising

# LINEAR BALL BEARING GUIDE

LOAD CAPACITY  
85~240 kgf



# CBL-E48

• Carriage selected from G60 or G67.

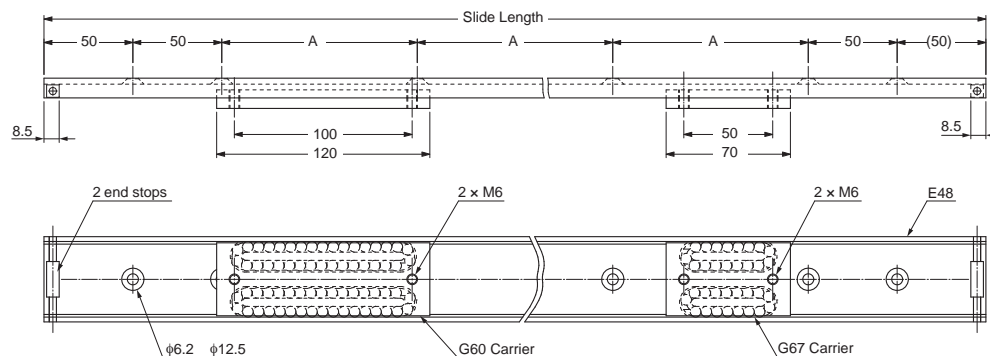
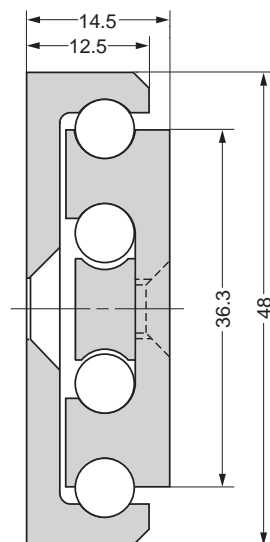

### LINEAR GUIDE

Item Code	Item Name	Material	Finish	Weight
—	CBL-E48	Steel	White Trivalent Chromate	1.7kg/m

Length: Please contact customer service for details.

### CARRIER

Item Code	Item Name	Material	Finish	Load Capacity				Weight	Balls
—	G60	Steel	Special surface treatment	2352N	240kgf	1176N	120kgf	0.24kg	68pcs
—	G67			1666N	170kgf	833N	85kgf	0.14kg	34pcs

Special surface treatment ··· Gaseous Nitro Carburising

# LINEAR BALL BEARING GUIDE

LOAD CAPACITY  
30-80 kgf



## CBL-E47

- Carriage selected from G60 or G67.
- End-stopper is sold separately.
- Limited stock available: please contact your dealer.

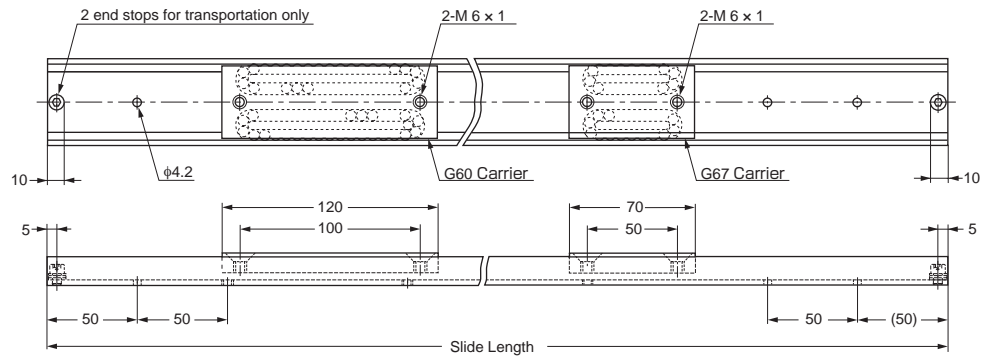
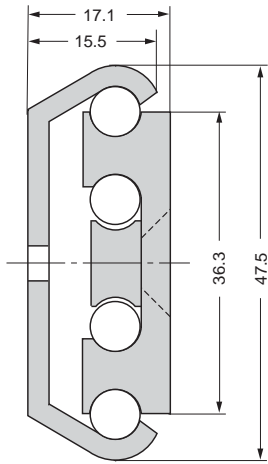

### LINEAR GUIDE

Item Code	Item Name	Material	Finish	Weight
—	CBL-E47	Steel	Yellow Zinc Chromate	1.3kg/m

### END STOPPER (OPTION)

Item Code	Item Name	Material	1set
—	CBL-ENDSTOP	Neoprene	2pcs

### CARRIER

Item Code	Item Name	Material	Finish	Load Capacity				Weight	Balls
—	G60	Steel	Special surface treatment	784N	80kgf	392N	40kgf	0.24kg	68pcs
—	G67			588N	60kgf	294N	30kgf	0.14kg	34pcs

Special surface treatment...Gaseous Nitro Carburising

# LINEAR BALL BEARING GUIDE

LOAD CAPACITY  
55-170 kgf



## CBL-E53

- Carriage selected from G53 or G57.

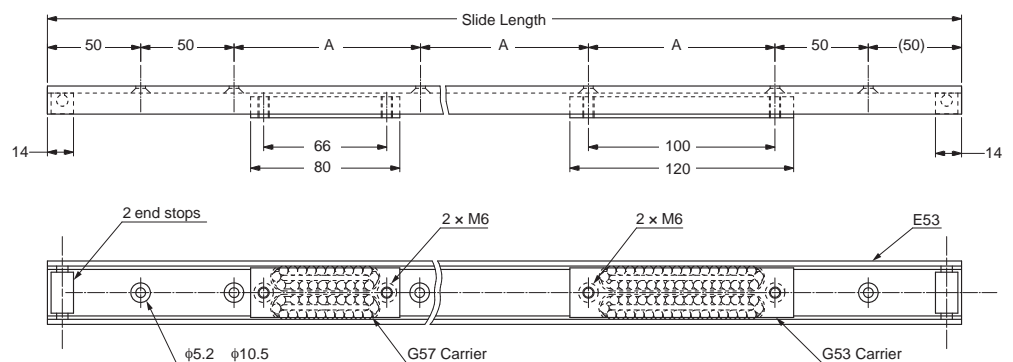
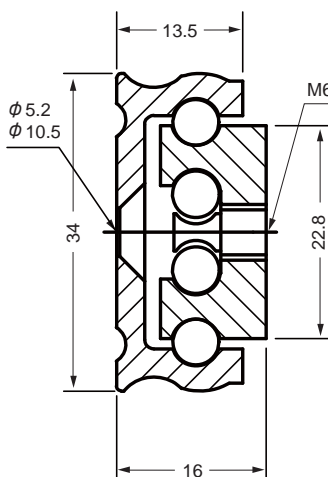

### LINEAR GUIDE

Item Code	Item Name	Material	Finish	Weight
—	CBL-E53	Steel	White Trivalent Chromate	1.7kg/m

Length: Please contact customer service for details.

### CARRIER

Item Code	Item Name	Material	Finish	Load Capacity				Weight	Balls
—	G53	Steel	Special surface treatment	1666N	170kgf	833N	85kgf	0.17kg	68pcs
—	G57			1078N	110kgf	539N	55kgf	0.1kg	44pcs

Special surface treatment...Gaseous Nitro Carburising

# LINEAR BALL BEARING GUIDE

LOAD CAPACITY  
20~50 kgf



# CBL-E28

• Carriage selected from G40 or G41.

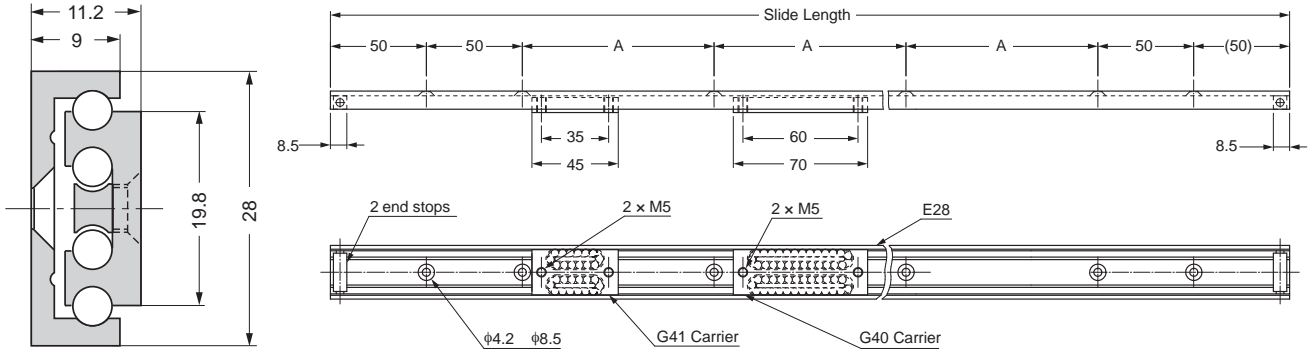

### LINEAR GUIDE

Item Code	Item Name	Material	Finish	Weight
—	CBL-E28	Steel	White Trivalent Chromate	0.76kg/m

Length: Please contact customer service for details.

### CARRIER

Item Code	Item Name	Material	Finish	Load Capacity				Weight	Balls
—	G40	Steel	Special surface treatment	490N	50kgf	245N	25kgf	0.06kg	52pcs
—	G41			392N	40kgf	196N	20kgf	0.04kg	28pcs

Special surface treatment: ···Gaseous Nitro Carburising

# ALUMINUM LINEAR BALL BEARING GUIDE

LOAD CAPACITY  
25~50 kgf



# CBL-D48

\*Cross section - Actual size shown

• Aluminum linear guide.

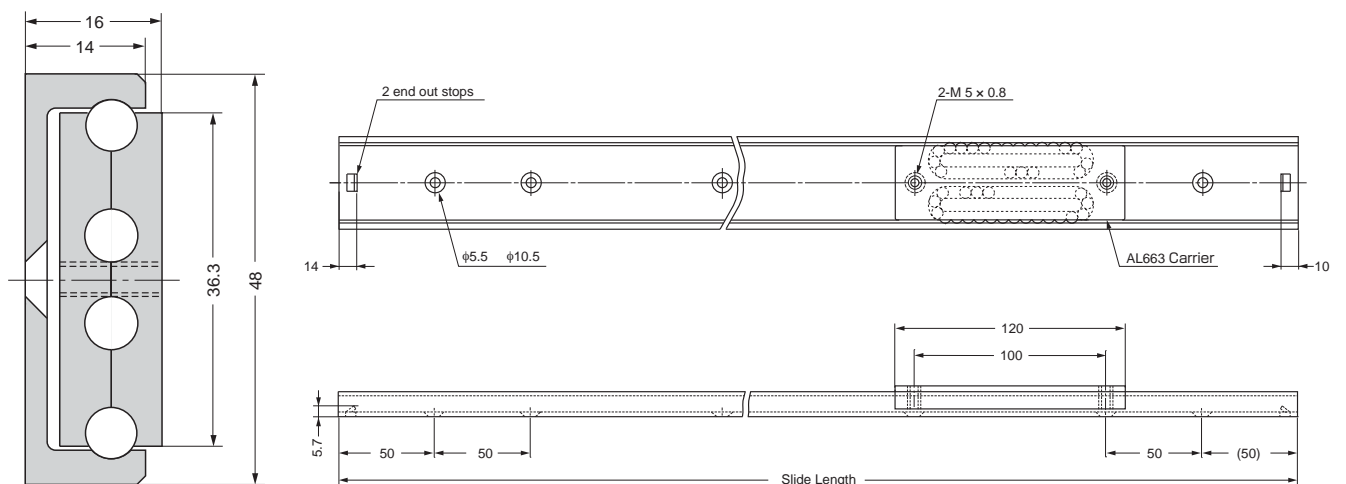

### LINEAR GUIDE

Item Code	Item Name	Material	Finish	Weight
—	CBL-D48	Aluminum Alloy	Anodized	0.53kg/m

Length: Please contact customer service for details.

### CARRIER

Item Code	Item Name	Material	Finish	Load Capacity				Weight	Balls
—	AL60	Aluminum Alloy	Anodized	490N	50kgf	245N	25kgf	0.12kg	56pcs

# ALUMINUM LINEAR BALL BEARING GUIDE

LOAD CAPACITY  
2-5 kgf

NO SCREW

ALUMINIUM

# CBL-D409

• Aluminum linear guide.

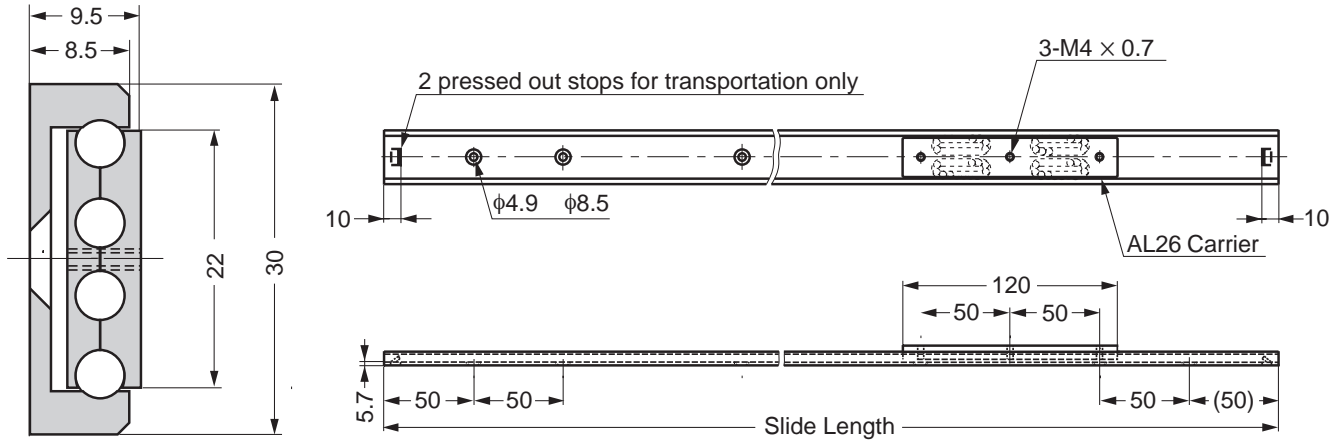

### LINEAR GUIDE

Item Code	Item Name	Material	Finish	Weight
—	CBL-D409	Aluminum Alloy	Anodized	0.26kg/m

Length: Please contact customer service for details.

### CARRIER

Item Code	Item Name	Material	Finish	Load Capacity		Weight	Balls
—	AL26	Aluminum Alloy	Anodized	49N	5kgf / 19.6N	2kgf	0.04kg / 52pcs

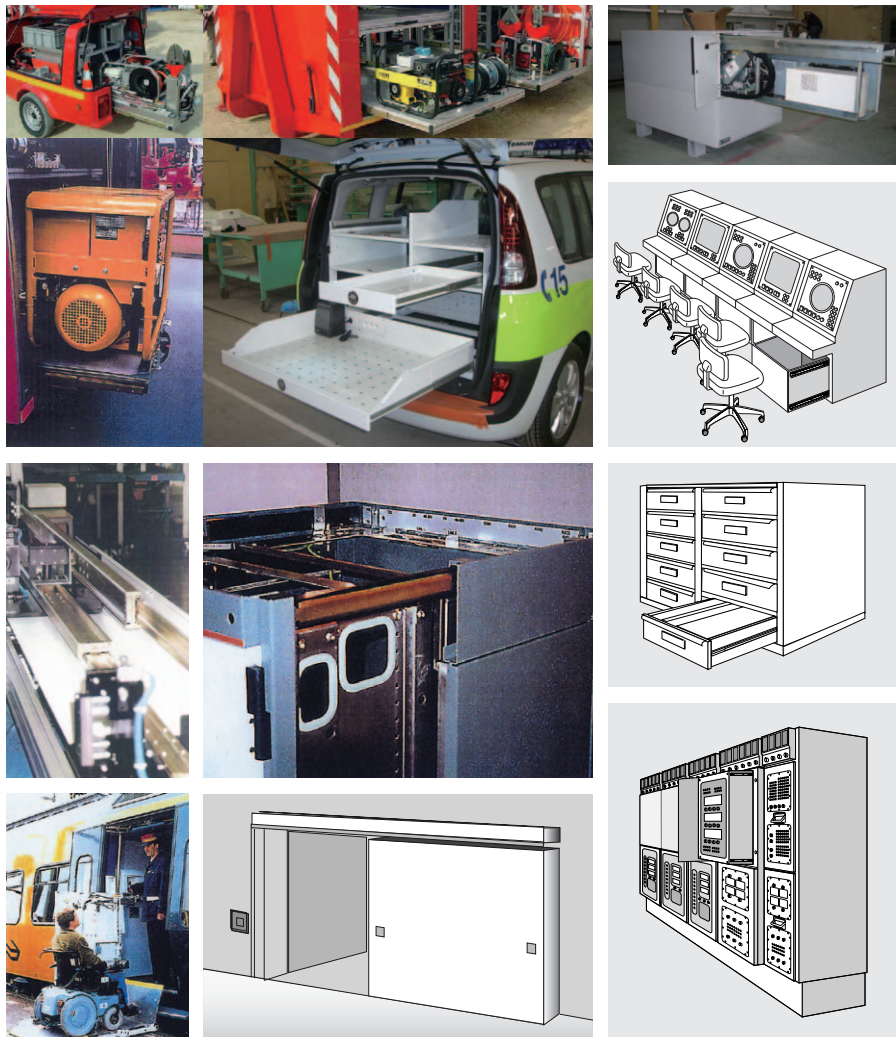
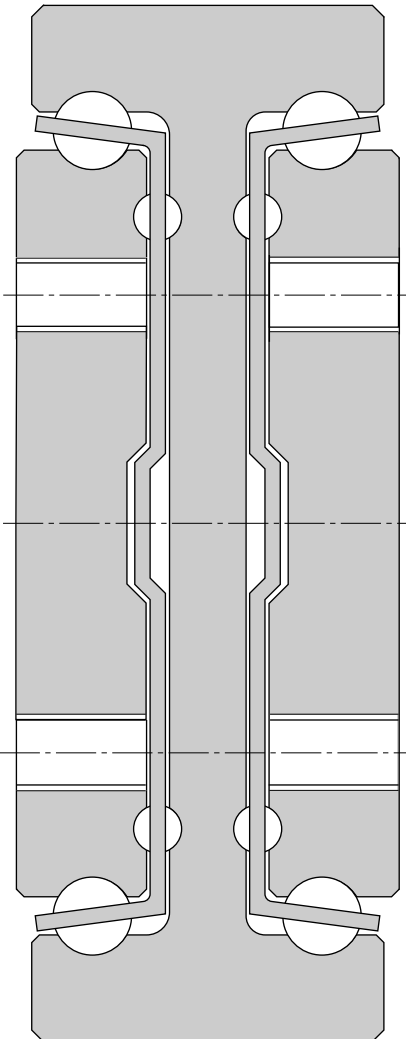

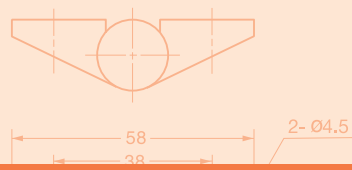
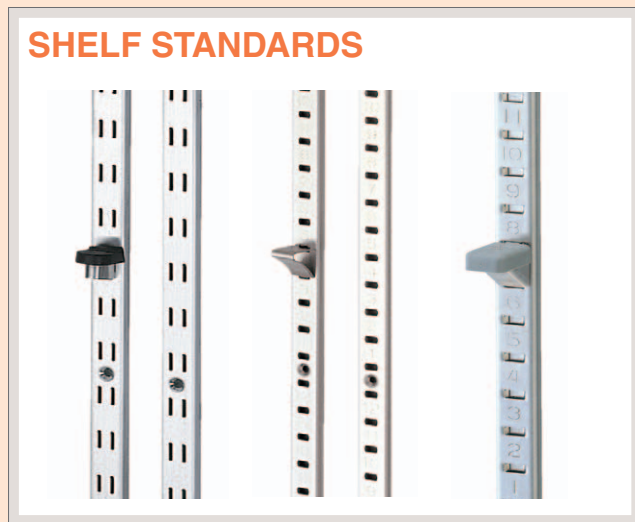
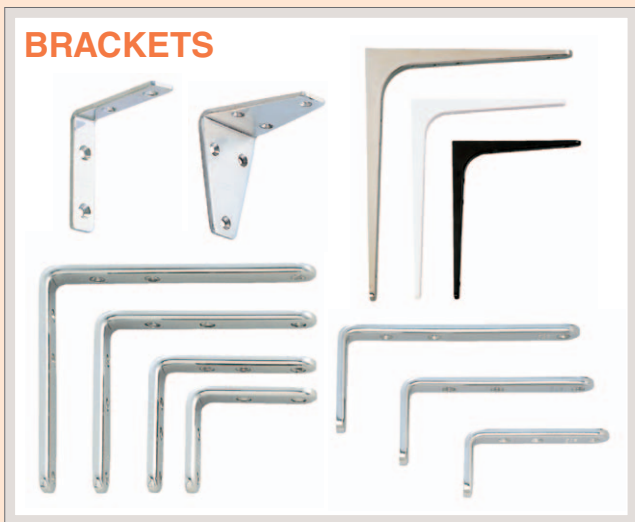

## HOOKS & BRACKETS

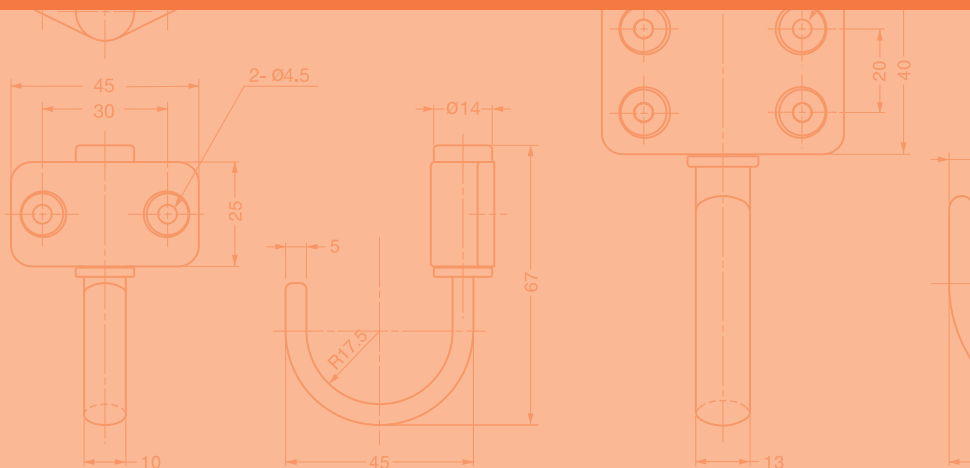

**LARGE HOOKS**

Picture	Item Name	Material	Load Capacity (kgf)	Page
	XL-CUF	STAINLESS 303 STEEL	15 - 32	216
	JF-45, 70, 110	STAINLESS 303 STEEL	10 - 12	216
	JF-50, 80, 120	STAINLESS 303 STEEL	12 - 22	217
	JFT-180, 260	STAINLESS 303 STEEL	10 - 15	217
	XL-SB210	STAINLESS 304 STEEL	20 - 38	218
	XL-SF115	STAINLESS 304 STEEL	38	218
	XL-CUJ	STAINLESS 303 STEEL	14 - 19	219
	DS-H	STAINLESS 303 STEEL	10	219

**SMALL HOOKS**

Picture	Item Name	Material	Load Capacity (kgf)	Page
	TY	STAINLESS 304 STEEL	3 - 8	220
	TF	STAINLESS 304 STEEL	3 - 12	220
	TL	STAINLESS 304 STEEL	5 - 12	220
	C	STAINLESS 304 STEEL	5 - 8	221
	B	STAINLESS 304 STEEL	5 - 7	221
	PF	STAINLESS 304 STEEL	2	221
	EU	STAINLESS 316 STEEL	20 - 30	222
	HJT	STAINLESS 304 STEEL	8 - 10	222
	2H	STAINLESS 304 STEEL	6 - 10	222
	HJ	STAINLESS 304 STEEL	8 - 10	222
	KB-H-35, 40	STAINLESS 303 STEEL	16	223
	EL-25, 30	STAINLESS 304 STEEL	20	223
	TA3	STAINLESS 304 STEEL	16	223
	EP-25, 40	STAINLESS 304 STEEL	20	223
	EW-65E, 80E	STAINLESS 304 STEEL	20	224
	FC-50T1, 65T1, 50, 65	STAINLESS 304 STEEL TITANIUM	10 - 12	224
	KB-F-70	STAINLESS 304 STEEL		224

Picture	Item Name	Material	Load Capacity (kgf)	Page
	KB-F-75	STAINLESS 303 STEEL	-	224
	RB-102	STAINLESS 304 STEEL	-	225
	RI-074	STAINLESS 304 STEEL	5	225
	RN-50	STAINLESS 304 STEEL	9.4	225

**LATCH HOOKS**

Picture	Item Name	Material	Load Capacity (kgf)	Page
	EN-K	STAINLESS 316 STEEL	20 - 60	226
	EN-R80	STAINLESS 316 STEEL	20	226
	WH	STAINLESS 304 STEEL	15	226
	EN-R100F	STAINLESS 316 STEEL	60	227
	EN-R80-K	STAINLESS 316 STEEL	20	227

**SWING HOOKS**

Picture	Item Name	Material	Load Capacity (kgf)	Page
	JF-T	STAINLESS 304 STEEL	10	228
	TK	STAINLESS 304 STEEL	8 - 12	228
	TZ-360	STAINLESS 304 STEEL	3 - 6	228
	DZ-270	STAINLESS 304 STEEL	3 - 6	229
	RF-D35	STAINLESS 304 STEEL	10.6	229
	EY-R	STAINLESS 316 STEEL	500 - 1200	229
	XL-JSF40TT	STAINLESS 304 STEEL	50	230
	UC	STAINLESS 304 STEEL	5.6 - 6.7	230
	UJ	STAINLESS 304 STEEL	6.7 - 8.9	230
	RF-U50	STAINLESS 304 STEEL	6.1	231
	RF-50	STAINLESS 304 STEEL	3	231



**RECESSED HOOKS**

Picture	Item Name	Load Capacity (kgf)	Page
	NF-R64	20	232







Picture	Item Name	Load Capacity (kgf)	Page
	NF-60	20	233







**HOOK**

Picture	Item Name	Load Capacity (kgf)	Page
	WB-901145	-	234
	WB-901146	-	234

**FOLDING BRACKETS**

Picture	Item Name	Material	Load Capacity (kgf)	Page
	BOS	STAINLESS 304 STEEL	33 - 40	235
	GTS-300	STAINLESS 304 STEEL	6	236
	BTO		40.8	236
	EB-303/EP	STAINLESS 304 STEEL	150	237
	388	ALUMINIUM	35 - 80	237

**BRACKETS**



Picture	Item Name	Material	Load Capacity (kgf)	Page
	BY	STAINLESS 304 STEEL	50	235
	BT, BTK	STAINLESS 304 STEEL	15 - 82.5	238
	XL-SA01	STAINLESS 304 STEEL	12 - 23	239
	SU-A	STAINLESS 304 STEEL	9 - 24	239
	SU-B	STAINLESS 304 STEEL	10 - 13	240
	SU	STAINLESS 304 STEEL	4 - 6	240
	SV	STAINLESS 304 STEEL	8 - 14	240





**SHELF ORGANIZERS**

Picture	Item Name	Material	Page
	SPHL	STAINLESS 304 STEEL	Page 241
	SPHL-30		
	SPHL-25		





Picture	Item Name	Material	Page
	SPH	STAINLESS 304 STEEL	Page 242-243
	SP-18E		
	SPH-20		
	SPH-5		
	SPH-15		

Picture	Item Name	Material	Page
	SP	STAINLESS 430 STEEL / STAINLESS 304 STEEL	Page 244-245
	SP-35		
	SPB-15R		
	SPF-20LC		
	SPB-20		
	SPF-20		
	SPF-20A		

Picture	Item Name	Material	Page
	SM	STAINLESS 304 STEEL	Page 246
	SMB-15R		
	SPM-20B		

Picture	Item Name	Material	Page
	SPE	STAINLESS 430 STEEL	Page 247
	SPE-FB20		
	SPE-FC20		
	AP-EC20		

Picture	Item Name	Material	Page
	SPN	STAINLESS 430 STEEL	Page 248
	SPN-15		
	SPN-17EC		

Picture	Item Name	Material	Page
	AP-DM, AP-DH	ALUMINIUM	Page 249
	AP-FB20		
	AP-FC20		
	AP-EC20		

# LARGE UTILITY HOOK



## XL-CUF

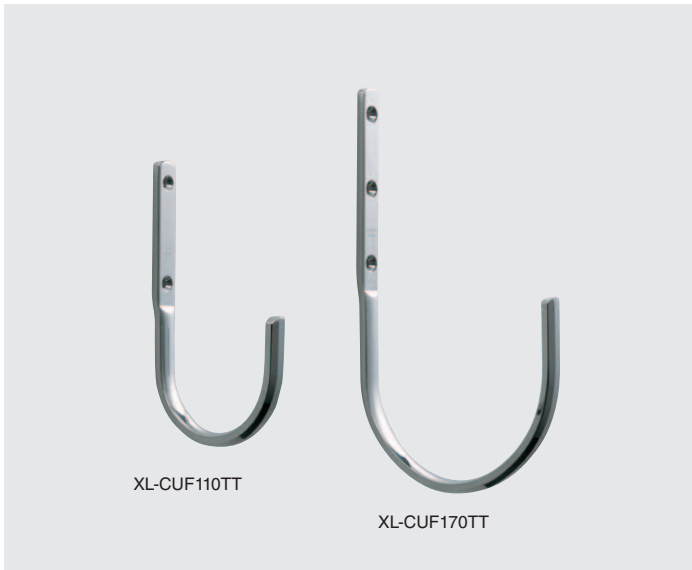

XL-CUF110TT

XL-CUF170TT

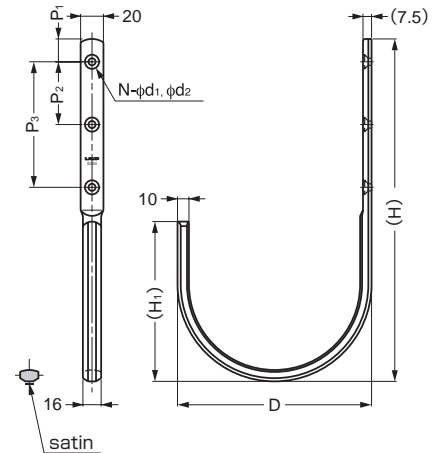

Item Code	Item Name	Material	Finish	D	(H)	(H <sub>1</sub> )	P <sub>1</sub>	P <sub>2</sub>	P <sub>3</sub>	N	d <sub>1</sub>	d <sub>2</sub>	Load Capacity	Box	Carton
110-020-014	XL-CUF110TT	Stainless Steel (SUS303)	Mirror and Satin Combination	112	198	91	17	—	70	2	5.2	10.5	314N 32kgf	5pcs	30pcs
110-020-015	XL-CUF170TT	Stainless Steel (SUS303)	Mirror and Satin Combination	173	300	138.5	20	55	110	3	6.2	12.5	147N 15kgf	5pcs	20pcs

# LARGE UTILITY HOOK



## JF45, 70, 110

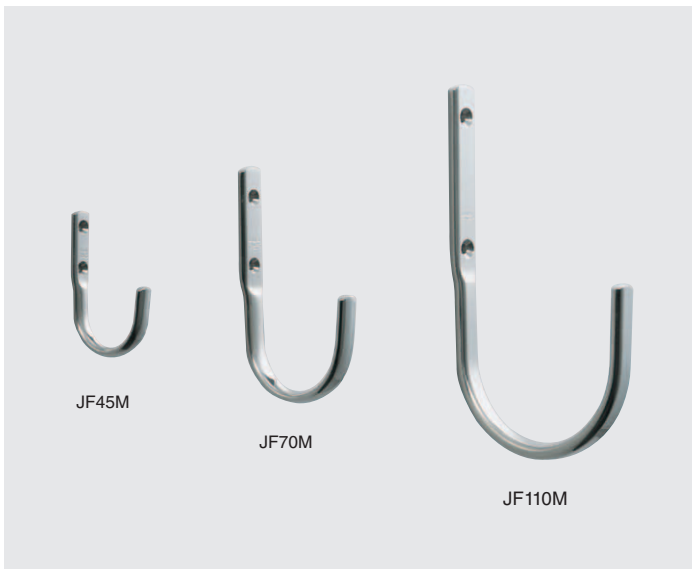

JF45M

JF70M

JF110M

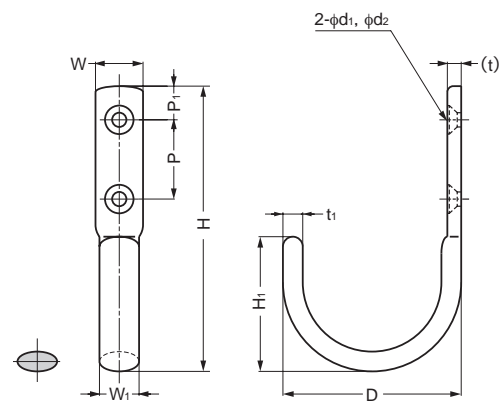

Item Code	Item Name	Material	Finish	D	W	W <sub>1</sub>	H	H <sub>1</sub>	P	P <sub>1</sub>	t	t <sub>1</sub>	d <sub>1</sub>	d <sub>2</sub>	Load Capacity	Weight	Box	Carton
110-020-071	JF45M	Stainless Steel (SUS303)	Mirror	45	12	10	72	34	20	8.5	3.5	5	3.8	7.2	98N 10kgf	40g	20pcs	120pcs
110-020-043	JF70M	Stainless Steel (SUS303)	Mirror	68	16	13	120	55	35	15	4	6	4.3	8.6	98N 10kgf	95g	6pcs	36pcs
110-020-073	JF110M	Stainless Steel (SUS303)	Mirror	110	18	14	200	90	70	17	5.5	8	5.3	10.6	117.6N 12kgf	270g	5pcs	30pcs

# LARGE UTILITY HOOK



JF50, 80, 120

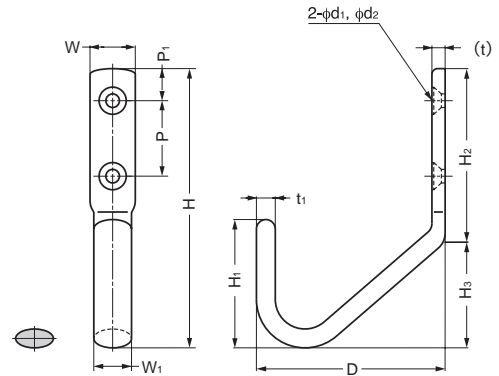
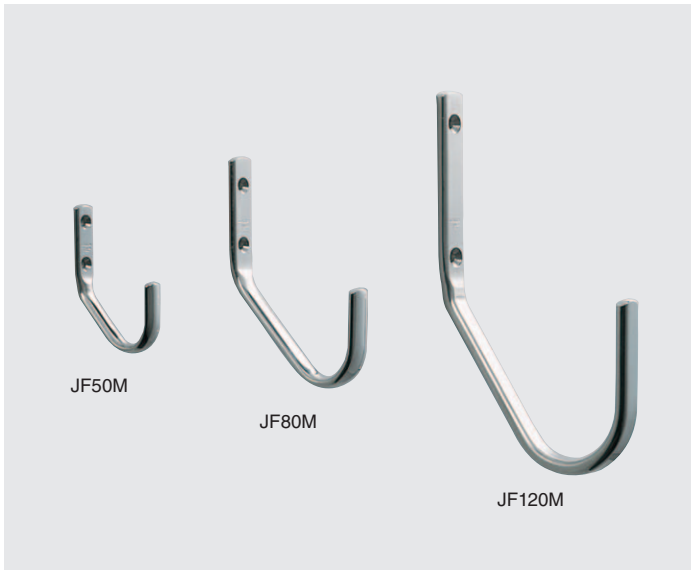

Item Code	Item Name	Material	Finish	D	W	W <sub>1</sub>	H	H <sub>1</sub>	H <sub>2</sub>	H <sub>3</sub>	P	P <sub>1</sub>	t	t <sub>1</sub>	d <sub>1</sub>	d <sub>2</sub>	Load Capacity	Weight	Box	Carton	
110-020-072	JF50M	Stainless Steel (SUS303)	Mirror	50	12	10	74	34	46	28	20	8.5	3.5	5	3.8	7.2	117.6N	12kgf	40g	20pcs	120pcs
110-020-044	JF80M	Stainless Steel (SUS303)	Mirror	80	16	13	115	50	65	50	30	15	4	6	4.3	8.6	196N	20kgf	95g	6pcs	36pcs
110-020-074	JF120M	Stainless Steel (SUS303)	Mirror	120	18	14	200	90	112	88	70	17	5.5	8	5.3	10.6	215.6N	22kgf	260g	5pcs	30pcs

# LARGE UTILITY HOOK



JFT180, 260

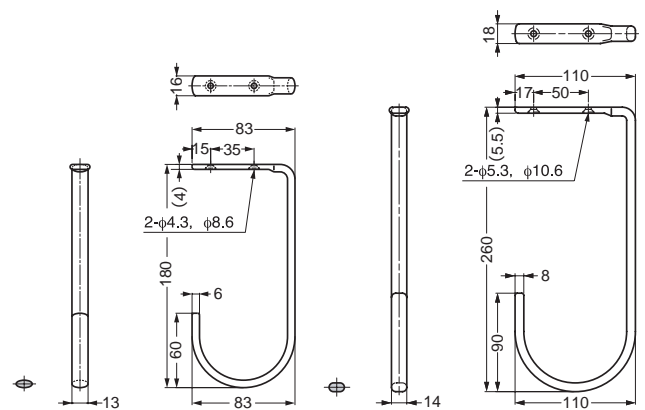
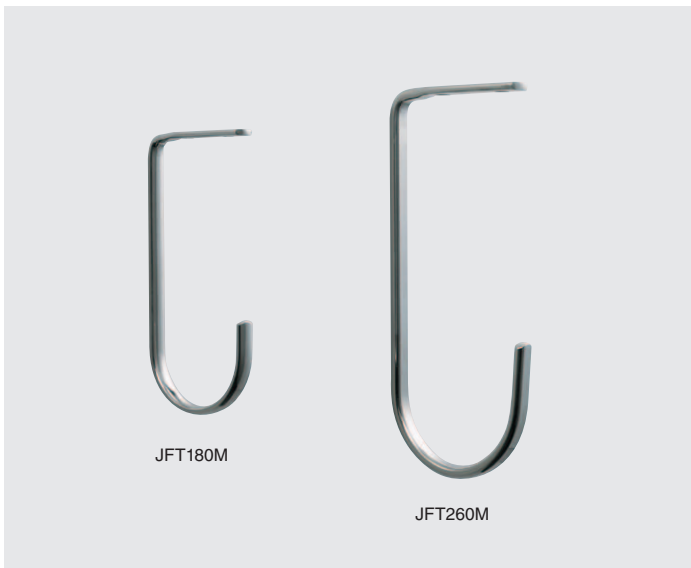

JFT180M

JFT260M

Item Code	Item Name	Material	Finish	Load Capacity	Weight	Box	Carton
110-020-080	JFT180M	Stainless Steel (SUS303)	Mirror	98N 10kgf	180g	5pcs	30pcs
110-020-081	JFT260M	Stainless Steel (SUS303)	Mirror	147N 15kgf	380g	5pcs	30pcs

# LARGE UTILITY HOOK



## XL-SB210



- Stainless steel bracket with dimensional design.
- Two-in-one hook.

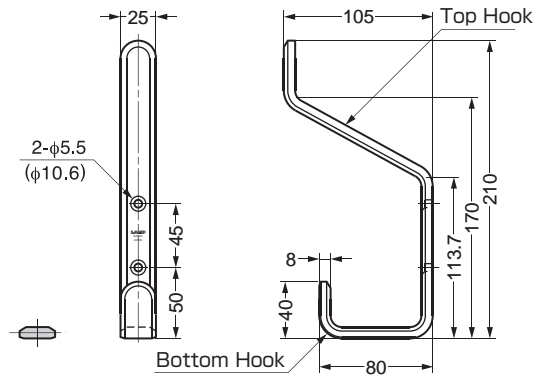

Item Code	Item Name	Material	Finish	Load Capacity			Weight	Box	Carton	
				Top Hook		Bottom Hook				
110-020-144	XL-SB-210-S	Stainless Steel (SUS304)	Satin	196N	20kgf	372.4N	38kgf	500g	2pcs	12pcs
110-020-145	XL-SB-210-M	Stainless Steel (SUS304)	Mirror	196N	20kgf	372.4N	38kgf	500g	2pcs	12pcs

# LARGE UTILITY HOOK



## XL-SF115



- Stainless steel bracket with dimensional design.

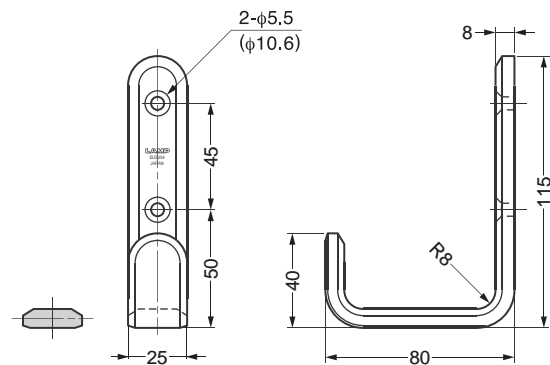

Item Code	Item Name	Material	Finish	Load Capacity		Weight	Box	Carton
110-020-142	XL-SF-115-S	Stainless Steel (SUS304)	Satin	372.4N	38kgf	280g	4pcs	24pcs
110-020-143	XL-SF-115-M	Stainless Steel (SUS304)	Mirror	372.4N	38kgf	280g	4pcs	24pcs

# LARGE UTILITY HOOK



**XL-CUJ**

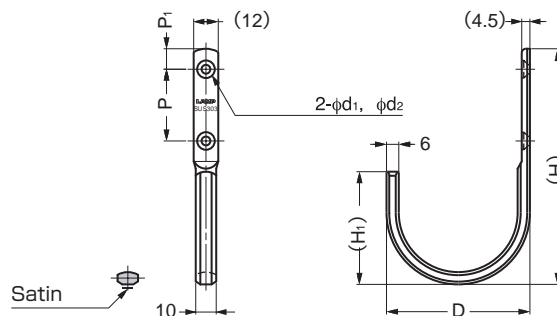

Item Code	Item Name	Material	Finish	D	H	H <sub>1</sub>	P	P <sub>1</sub>	d <sub>1</sub>	d <sub>2</sub>	Load Capacity	Box	Carton
110-020-012	XL-CUJ45TT	Stainless Steel (SUS303)	Mirror and Satin combination	46	75	36	20	8.5	3.8	7.2	186.2N 19kgf	20pcs	120pcs
110-020-013	XL-CUJ70TT	Stainless Steel (SUS303)	Mirror and Satin combination	72	112	56	35	10	4.3	8.6	137.2N 14kgf	10pcs	60pcs

# LARGE UTILITY HOOK



**DS-H**

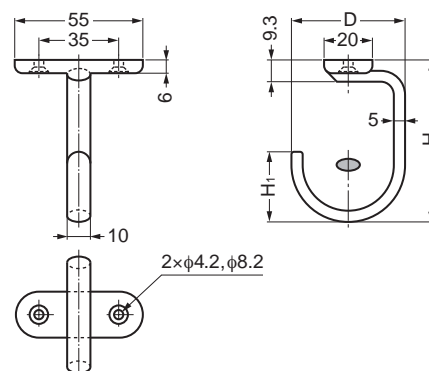

Item Code	Item Name	Material	Finish	D	H	H <sub>1</sub>	Load Capacity	Box
110-020-205	DS-H-50	Stainless Steel (SUS303)	Mirror	50	70	30	98N 10kgf	5pcs
110-020-206	DS-H-60	Stainless Steel (SUS303)	Mirror	60	100	40	98N 10kgf	5pcs

## WIRE HOOK



TEST

LOAD CAPACITY  
3-8 kgf

STAINLESS  
304  
STEEL

TY

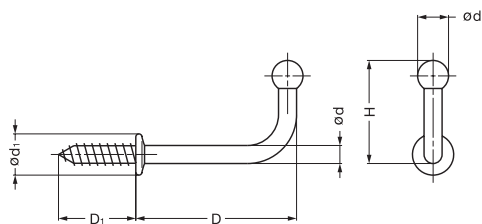

Item Code	Item Name	Material	Finish	D	D <sub>1</sub>	H	d	d <sub>1</sub>	d <sub>2</sub>	Load Capacity	Weight	Box	Carton	
110-020-046	TY-20	Stainless Steel (SUS304)	Polished	21.8	11	14	2.7	6.5	4.5	29.4N	3kgf	1.5g	200pcs	7,200pcs
110-020-047	TY-25	Stainless Steel (SUS304)	Polished	27	13	17	3	7	5	29.4N	3kgf	3g	100pcs	3,600pcs
110-020-048	TY-30	Stainless Steel (SUS304)	Polished	31.2	15	20	3.5	8	6	68.6N	7kgf	5g	100pcs	1,800pcs
110-020-049	TY-35	Stainless Steel (SUS304)	Polished	36.5	20	23	4	9	6.5	68.6N	7kgf	7g	50pcs	1,800pcs
110-020-050	TY-40	Stainless Steel (SUS304)	Polished	43.5	20	27	4.5	10	7.5	78.4N	8kgf	11g	50pcs	900pcs

## WIRE HOOK



TEST

LOAD CAPACITY  
3-12 kgf

STAINLESS  
304  
STEEL

TF

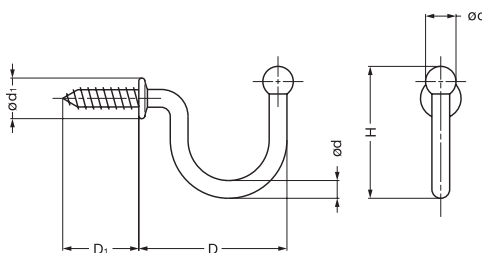
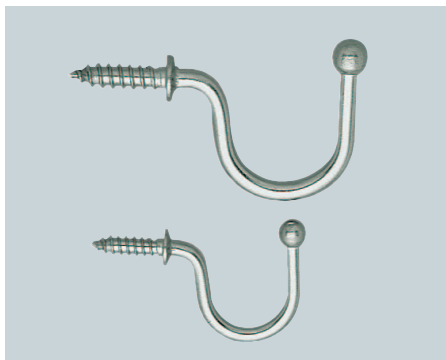

Item Code	Item Name	Material	Finish	D	D <sub>1</sub>	H	d	d <sub>1</sub>	d <sub>2</sub>	Load Capacity	Weight	Box	Carton	
110-020-055	TF-20	Stainless Steel (SUS304)	Polished	20.8	11	20	2.7	6.5	4.5	29.4N	3kgf	3g	200pcs	7,200pcs
110-020-056	TF-30	Stainless Steel (SUS304)	Polished	29.2	15	26	3.5	8	6	68.6N	7kgf	5.5g	100pcs	1,800pcs
110-020-057	TF-35	Stainless Steel (SUS304)	Polished	40.5	20	35	4.5	10	7.5	117.6N	12kgf	13.5g	50pcs	900pcs

## WIRE HOOK



TEST

LOAD CAPACITY  
5-12 kgf

STAINLESS  
304  
STEEL

TL

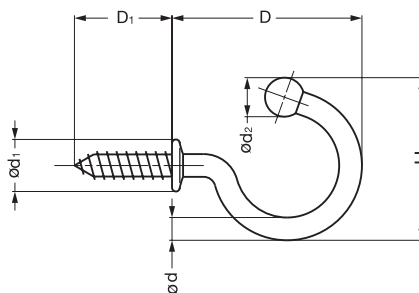

Item Code	Item Name	Material	Finish	D	D <sub>1</sub>	H	d	d <sub>1</sub>	d <sub>2</sub>	Load Capacity	Weight	Box	Carton	
110-020-062	TL-15	Stainless Steel (SUS304)	Polished	16.8	11	15	2.7	6.5	4.5	49N	5kgf	1.9g	200pcs	7,200pcs
110-020-063	TL-20	Stainless Steel (SUS304)	Polished	22.8	11	20	2.7	6.5	4.5	49N	5kgf	2.1g	100pcs	3,600pcs
110-020-064	TL-30	Stainless Steel (SUS304)	Polished	29.2	15	25	3.5	8	6	49N	5kgf	6g	50pcs	900pcs
110-020-065	TL-40	Stainless Steel (SUS304)	Polished	40.5	20	34	4.5	10	7.5	117.6N	12kgf	13.5g	50pcs	900pcs

# HOOK

TEST

LOAD CAPACITY  
5-8 kgf

STAINLESS  
304  
STEEL

C

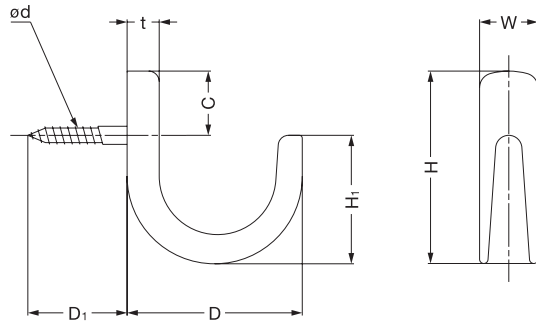
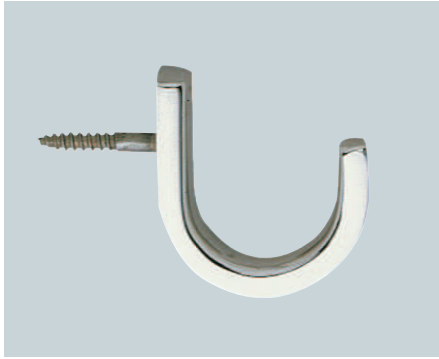

Item Code	Item Name	Material	Finish	D	D <sub>1</sub>	W	H	H <sub>1</sub>	d	P	t	Load Capacity	Weight	Box	Carton	
110-026-010	CS-22	Stainless Steel (SUS304)	Mirror	22	17	9	27	15	3.1	9	4	49N	5kgf	10g	30pcs	600pcs
110-026-011	CL-30	Stainless Steel (SUS304)	Mirror	30	17	10	33	22	3.1	11	5	78.4N	8kgf	18.5g	20pcs	400pcs

# HOOK

LOAD CAPACITY  
5-7 kgf

STAINLESS  
304  
STEEL

B

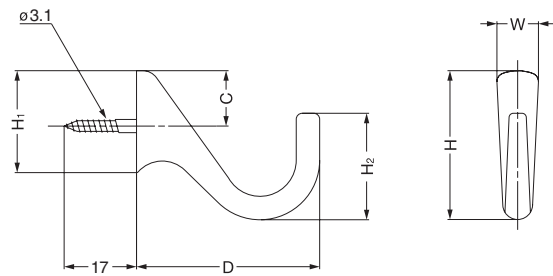

Item Code	Item Name	Material	Finish	D	W	H	H <sub>1</sub>	H <sub>2</sub>	C	Load Capacity	Weight	Box	Carton	
110-026-012	BS-33	Stainless Steel (SUS304)	Mirror	33	9	29	16	20	8	49N	5kgf	15g	30pcs	600pcs
110-026-013	BL-43	Stainless Steel (SUS304)	Mirror	43	10	35	24	25	13	68.6N	7kgf	29g	20pcs	400pcs

# HOOK

LOAD CAPACITY  
2 kgf

STAINLESS  
304  
STEEL

PF



Pin / Stainless Steel ø1.5

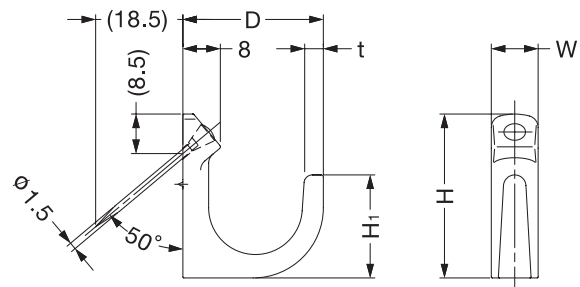

Item Code	Item Name	Material	Finish	D	W	H	H <sub>1</sub>	t	Load Capacity	Weight	Box	Carton
110-020-500	PF-22	Stainless Steel (SUS304)	Mirror	22	9	30	16	3	19.6N	2kgf	13g	200pcs
110-020-501	PF-30	Stainless Steel (SUS304)	Mirror	30	10	35	22	4	19.6N	2kgf	23g	200pcs

# FORK HOOK





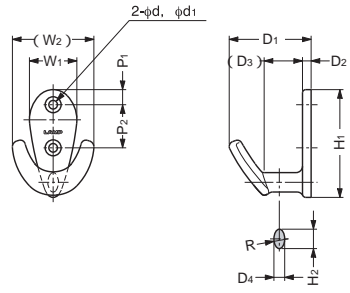

- Hook with unique design.
- Can hang 3 items at same time. Two on the tips and one on the neck.
- Two-tip shape ideal to hang hats, caps etc.

Item Code	Item Name	Material (*)	Finish	H <sub>1</sub>	H <sub>2</sub>	W <sub>1</sub>	W <sub>2</sub>	D <sub>1</sub>	D <sub>2</sub>	D <sub>3</sub>	D <sub>4</sub>	P <sub>1</sub>	P <sub>2</sub>	d	d <sub>1</sub>	Load Capacity	Weight	Box	Carton	
110-020-270	EU-50	Stainless Steel (SCS14)	Mirror	50	9	22	38	38	4	17.8	5	7	20	4	7.4	196N	20kgf	42g	20pcs	120pcs
110-020-271	EU-72	Stainless Steel (SCS14)	Mirror	72	14	32	56	52	6	23	8	10	34	4.6	8.6	294N	30kgf	118g	10pcs	60pcs

(\*) SCS14 is similar to SUS316

# HOOK





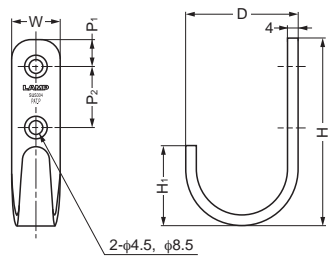

- 4mm thick material used for excellent durability.

Item Code	Item Name	Material	Finish	H	H <sub>1</sub>	D	W	P <sub>1</sub>	P <sub>2</sub>	Load Capacity	Weight	Box	Carton
110-020-028	HJT-55S	Stainless Steel (SUS304)	Satin	55	23	33	15	8	19	98N	10kgf	34g	300pcs
110-020-027	HJT-70S	Stainless Steel (SUS304)	Satin	70	30	43	18	10	23	78.4N	8kgf	53g	200pcs

# HOOK





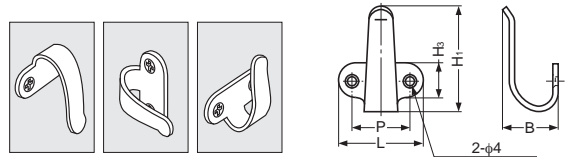

- Unique design, also can be used as a pull.

Item Code	Item Name	Material	Finish	L	P	H <sub>3</sub>	H <sub>1</sub>	B	Load Capacity	Weight	Box	Carton
110-010-142	2H-20S	Stainless Steel (SUS304)	Satin	28	18	10	30	18	98N	10kgf	13g	1,200pcs
110-010-143	2H-30S	Stainless Steel (SUS304)	Satin	32.5	20	13	39	18	98N	10kgf	18g	1,000pcs
110-010-144	2H-40S	Stainless Steel (SUS304)	Satin	35	21.5	16	44	23	58.8N	6kgf	23g	800pcs
110-010-145	2H-50S	Stainless Steel (SUS304)	Satin	43	30	18	56	25	58.8N	6kgf	34g	500pcs

# HOOK





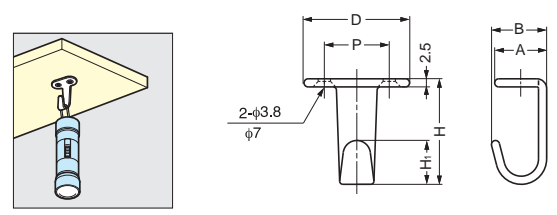

Item Code	Item Name	Material	Finish	D	P	H	H <sub>1</sub>	A	B	Load Capacity	Weight	Box	Carton
110-020-029	HJ-20S	Stainless Steel (SUS304)	Satin	28	16.4	27	11	10	17	98N	10kgf	11g	1,200pcs
110-020-078	HJ-30S	Stainless Steel (SUS304)	Satin	32.5	20	32.5	13.5	16	17	78.4N	8kgf	15g	600pcs
110-020-079	HJ-50S	Stainless Steel (SUS304)	Satin	43.5	30	47	22	21	22	98N	10kgf	30g	400pcs



# HOOK



# KB-H

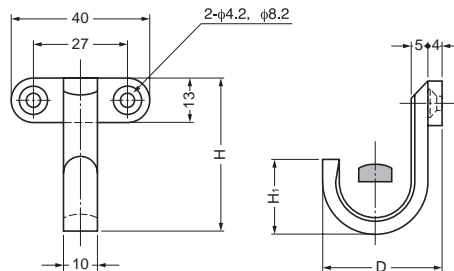

Item Code	Item Name	Material	Finish	D	H	H <sub>1</sub>	Load Capacity	Box
110-029-076	KB-H-35	Stainless Steel (SUS303)	Mirror	35	45	22	156.8N	16kgf
110-029-077	KB-H-40	Stainless Steel (SUS303)	Mirror	40	50	25	156.8N	16kgf

# HOOK



# EL

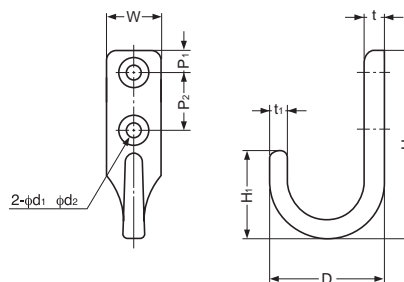

Item Code	Item Name	Material (*)	Finish	D	H	H <sub>1</sub>	t	t <sub>1</sub>	W	P <sub>1</sub>	P <sub>2</sub>	d <sub>1</sub>	d <sub>2</sub>	Load Capacity	Weight	Box	Carton	
110-026-004	EL-25	Stainless Steel (SCS13)	Mirror	26	40	19	5.5	4	12	12	5	3	6	196N	20kgf	19g	30pcs	300pcs
110-026-005	EL-30	Stainless Steel (SCS13)	Mirror	32	54.5	25	6	5	15	16	6	4	8	196N	20kgf	32g	20pcs	200pcs

(\*) SCS13 is similar to SUS304

# HOOK



# TA3

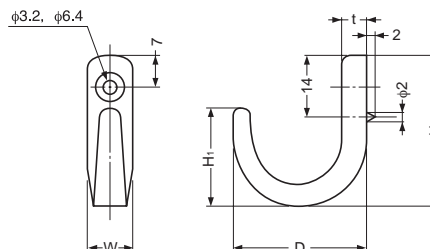

Item Code	Item Name	Material (*)	Finish	D	W	H	H <sub>1</sub>	t	Load Capacity	Weight	Box	Carton
110-026-008	TA3S	Stainless Steel (SCS13)	Mirror	22	9	29	16	4	156.8N	16kgf	10g	300pcs
110-026-009	TA3L	Stainless Steel (SCS13)	Mirror	30	10	34	22	5.5	156.8N	16kgf	19g	400pcs

(\*) SCS13 is similar to SUS304

# HOOK



# EP

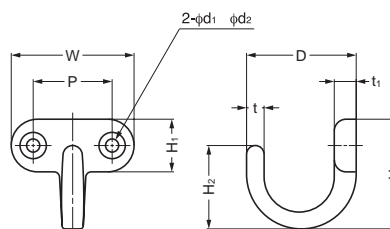

Item Code	Item Name	Material (*)	Finish	D	W	H	H <sub>1</sub>	H <sub>2</sub>	t <sub>1</sub>	t	P	d <sub>1</sub>	d <sub>2</sub>	Load Capacity	Weight	Box	Carton
110-026-000	EP-25	Stainless Steel (SCS13)	Mirror	25	28	25	12	19	5	4	18	3	6	196N	20kgf	16g	300pcs
110-026-001	EP-40	Stainless Steel (SCS13)	Mirror	32	36	33	16	25	6	5	23	4	8	196N	20kgf	31g	200pcs

(\*) SCS13 is similar to SUS304

# HOOK



EW

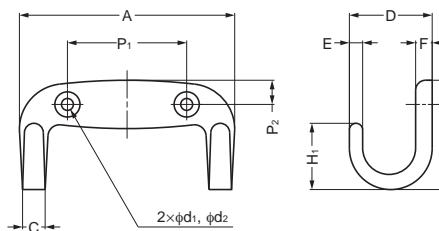

Item Code	Item Name	Material (*)	Finish	A	P <sub>1</sub>	C	D	E	F	P <sub>2</sub>	H	H <sub>1</sub>	d <sub>1</sub>	d <sub>2</sub>	Load Capacity	Weight	Box	Carton	
110-026-002	EW-65E	Stainless Steel (SCS13)	Mirror	65	36	6.5	25	4	5	7.3	33	20	3.6	7.6	196N	20kgf	52g	10pcs	100pcs
110-026-003	EW-80E	Stainless Steel (SCS13)	Mirror	80	44	8	32	5	6	9	42	25	4.2	8.8	196N	20kgf	93g	10pcs	100pcs

(\*) SCS13 is similar to SUS304

# HOOK



FC

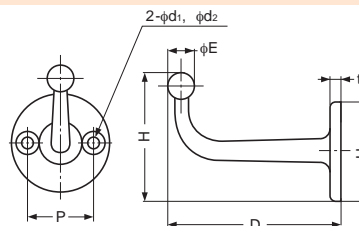

Item Code	Item Name	Material (*)	Finish	D	H	H <sub>1</sub>	t	P	d <sub>1</sub>	d <sub>2</sub>	E	Load Capacity	Weight	Box	Carton	
110-020-121	FC-50TI	Titanium	Shot Blast	47	37	28	3	18.5	3.3	6.5	6.5	—	—	17g	20pcs	120pcs
110-020-120	FC-65TI	Titanium	Shot Blast	65	44	35	4	22.5	4.2	8	8	—	—	34g	30pcs	180pcs
110-026-006	FC-50	Stainless Steel (SCS13)	Mirror	47	37	28	3	18.5	3.3	6.5	6.5	98 N	10kgf	25g	40pcs	480pcs
110-026-007	FC-65	Stainless Steel (SCS13)	Mirror	65	44	35	4	22.5	4.2	8	8	117.6N	12kgf	54.5g	20pcs	240pcs

(\*) SCS13 is similar to SUS304

# HOOK



KB-F-70

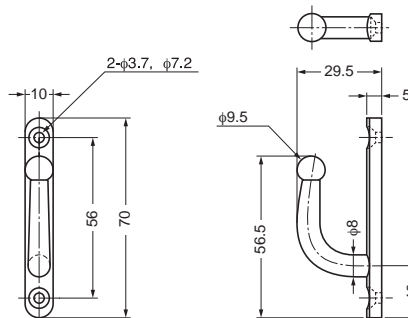

Item Code	Item Name	Material	Finish	Box
110-020-207	KB-F-70	Plate : Stainless Steel (SUS303) Hook : Stainless Steel (SUS304)	Mirror	5pcs

# HOOK



KB-F-75

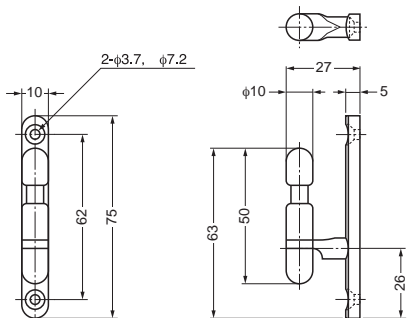

Item Code	Item Name	Material	Finish	Box
110-020-208	KB-F-75	Plate, Hook : Stainless Steel (SUS303) Arm : Stainless Steel (SUS304)	Mirror	5pcs

# DOUBLE HOOK



**RB-102**



- Can be used as a light duty tie up cleat.

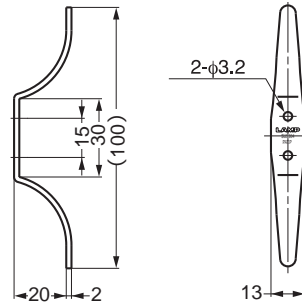
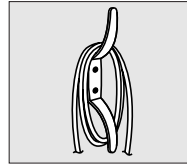

Item Code	Item Name	Material	Finish	Weight	Box	Carton
110-020-004	RB-102	Stainless Steel (SUS304)	Satin	16g	40pcs	400pcs

# DOUBLE HOOK



**RI-074**



- Unique two-in-one hook.

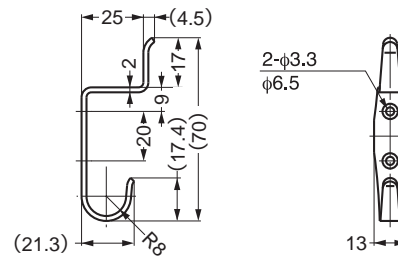

Item Code	Item Name	Material	Finish	Load Capacity	Weight	Box	Carton
110-020-006	RI-074	Stainless Steel (SUS304)	Satin	49N 5kgf	16g	40pcs	400pcs

# HOOK



**RN-50**



- Designed for use on partitions.

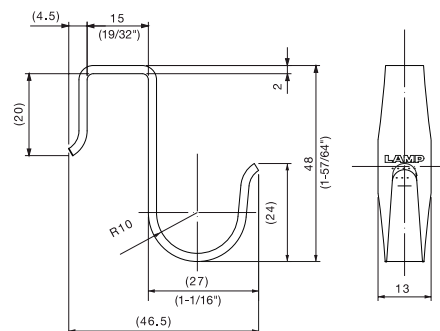

Item Code	Item Name	Material	Finish	Load Capacity	Weight	Box	Carton
110-020-005	RN-50	Stainless Steel (SUS304)	Satin	92.12N 9.4kgf	17g	40pcs	400pcs

# LATCH HOOK



EN-K



- Keeps items hooked, ideal for vibration or shock applications.

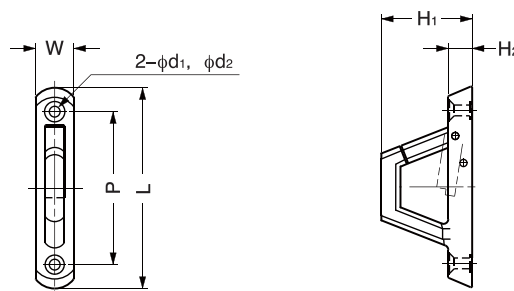

Item Code	Item Name	Material (*)	Finish	L	P	H <sub>1</sub>	H <sub>2</sub>	W	φd <sub>1</sub>	φd <sub>2</sub>	Max rope dia	Load Capacity	Weight	Box	Carton	
110-020-026	EN-K84	Stainless Steel (SCS14)	Mirror	84	64	38	10	16	4.5	8.5	φ 10mm	196N	20kgf	92g	10pcs	120pcs
110-010-109	EN-K120	Stainless Steel (SCS14)	Mirror	120	96	54	12	22	5.4	10.5	φ 20mm	588N	60kgf	280g	10pcs	60pcs

(\*) SCS14 is similar to SUS316

# LATCH HOOK



EN-R80



- Keeps items hooked, ideal for vibration or shock applications.

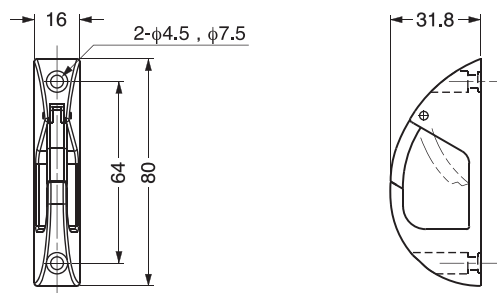

Item Code	Item Name	Material (*)	Finish	Max rope dia	Load Capacity	Weight	Box	Carton	
110-020-025	EN-R80	Stainless Steel (SCS14)	Mirror	φ 10mm	196N	20kgf	85g	10pcs	120pcs

(\*) SCS14 is similar to SUS316

# LATCH HOOK



WH



- Keep items hooked, ideal for vibration or shock applications.

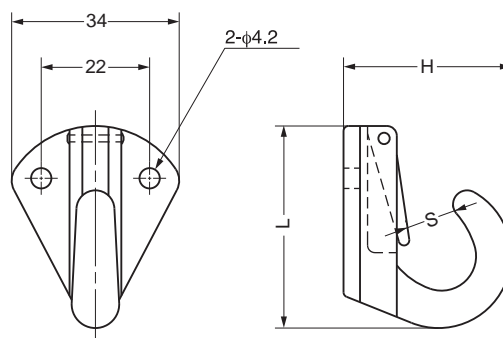

Item Code	Item Name	Material	Finish	L	H	S	Load Capacity	Weight	Box	Carton
110-029-158	WH-1	Stainless Steel	Polished	38	25	7	147N	15kgf	40g	200pcs
110-029-122	WH-2	Stainless Steel	Polished	41	34	10	147N	15kgf	55g	200pcs

# LATCH HOOK



# EN-R100F



- Keeps items hooked, ideal for vibration or shock applications.
- Swivels 180 degrees.

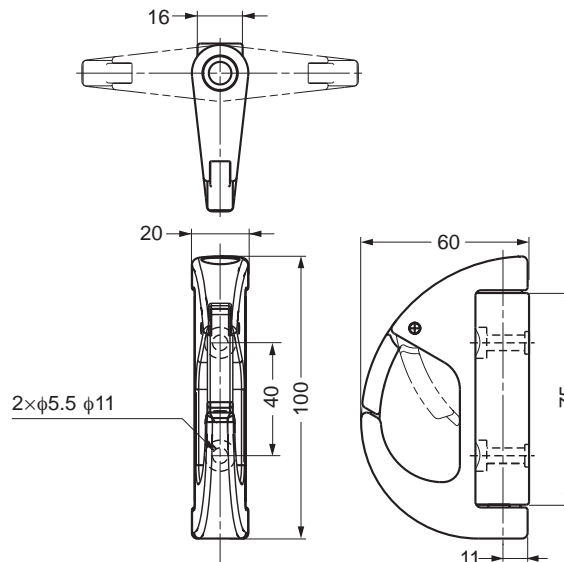
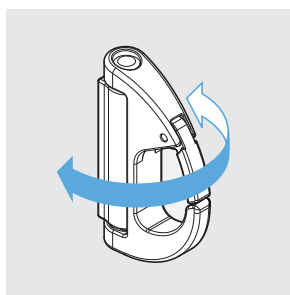

Item Code	Item Name	Material (*)	Finish	Max. rope dia.	Load Capacity	Weight	Box	Carton
110-018-675	EN-R100F	Stainless Steel (SCS14)	Mirror	φ 16mm	588N 60kgf	350g	10pcs	50pcs

(\*) SCS14 is similar to SUS316

# LATCH HOOK



# EN-R80-K



- Keep items hooked, ideal for vibration or shock applications.
- Padlock can be used together.

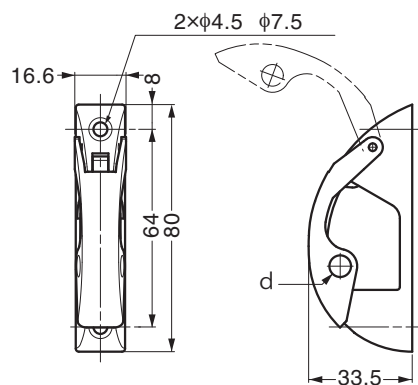
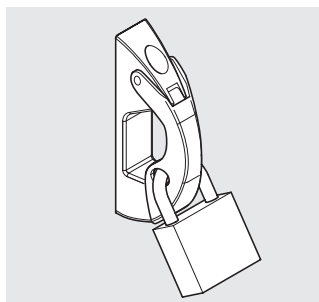

Item Code	Item Name	Material (*)	Finish	Max. rope dia.	d	Load Capacity	Weight	Box	Carton
110-022-201	EN-R80-K	Stainless Steel (SCS14)	Mirror	φ 10mm	φ 7mm	196N 20kgf	120g	10pcs	120pcs

(\*) SCS14 is similar to SUS316



# SWING HOOK (W/FRICTION)



JF-T

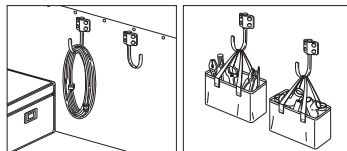

- Swivels 180 degrees.
- Hook has constant torque when swiveling.
- Ideal for vibration or shock applications.

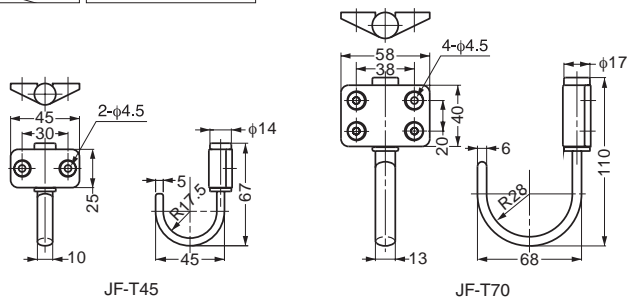

Item Code	Item Name	Material (*)	Finish	Load Capacity		Weight	Box
110-020-083	JF-T45	Stainless Steel (SCS13)	Mirror	98N	10kgf	90g	10pcs
110-020-084	JF-T70	Stainless Steel (SCS13)	Mirror	98N	10kgf	225g	10pcs

(\*) SCS13 is similar to SUS304

# SWING HOOK



TK



- Swivels 180 degrees.
- Hook has constant torque when swiveling.
- Ideal for vibration or shock applications.

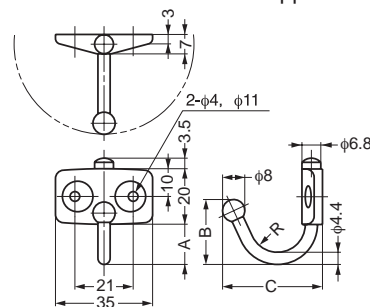

Item Code	Item Name	Specification	Material	Finish	A	B	C	R	Load Capacity	Weight	Box	Carton
110-020-250	TK-30	No friction	Stainless Steel (SUS304)	Polished	14.5	23.4	36	10	117.6N	12kgf	17g	100pcs, 1,000pcs
110-020-254	TK-45	No friction	Stainless Steel (SUS304)	Polished	19.4	28.4	44.3	15	78.4N	8kgf	20g	100pcs, 1,000pcs
110-020-018	TK-30F	Swivel friction	Stainless Steel (SUS304)	Polished	14.5	23.4	36	10	117.6N	12kgf	17g	100pcs, 1,000pcs
110-020-019	TK-45F	Swivel friction	Stainless Steel (SUS304)	Polished	19.5	28.4	44.3	15	78.4N	8kgf	20g	100pcs, 1,000pcs

# BUTTERFLY HOOK



TZ-360

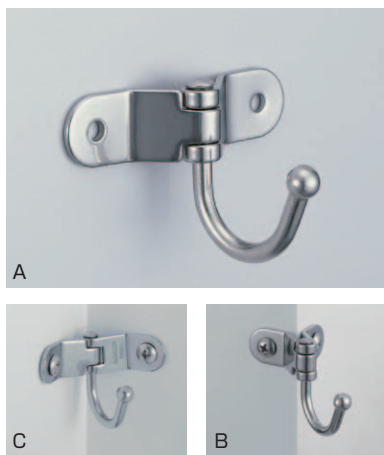

- Hinged flap allows flush or corner mount.
- Applicable angle: 90° ~ 270°

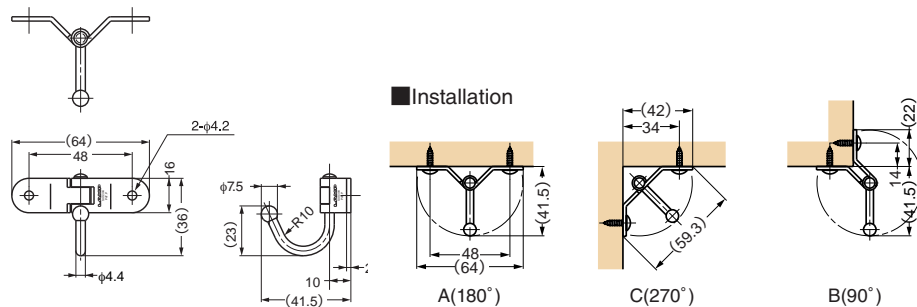

Item Code	Item Name	Material	Finish	Load Capacity			Weight	Box	Carton			
				A	B	C						
110-020-009	TZ-360	Stainless Steel (SUS304)	Polished	58.8N	6kgf	29.4N	3kgf	54.9N	5.6kgf	27g	50pcs	500pcs

# BUTTERFLY HOOK



DZ-270

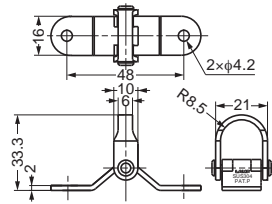

- Hinged flap allows flush or corner mount.
- Applicable angle: 90°~ 270°

Ceiling mount

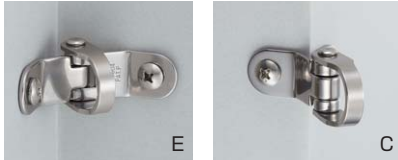
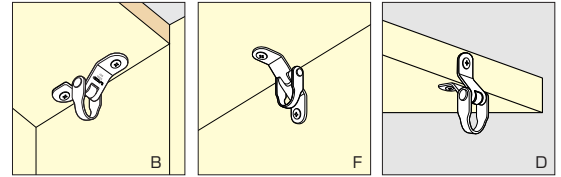

Wall mount

Load Capacity											
A		B		C		D		E		F	
58.8N	6kgf	78.4N	8kgf	29.4N	3kgf	78.4N	8kgf	54.9N	5.6kgf	58.8N	6kgf

Item Code	Item Name	Material	Finish	Weight	Box	Carton
110-020-248	DZ-270	Stainless Steel (SUS304)	Polished	29g	50pcs	500pcs

# HOOK



RF-D35

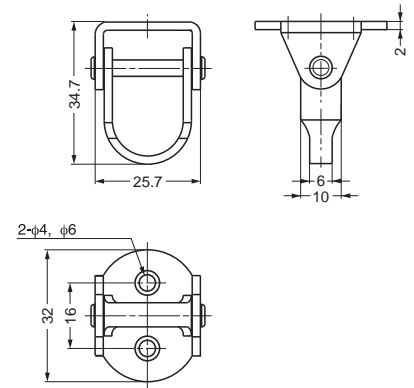

Item Code	Item Name	Material	Finish	Load Capacity				Weight	Box	Carton
				A		B				
110-020-249	RF-D35	Stainless Steel (SUS304)	Polished	52N	5.3kgf	104N	10.6kgf	27g	50pcs	400pcs

# HEAVY DUTY FOLDING PAD EYE



EY-R

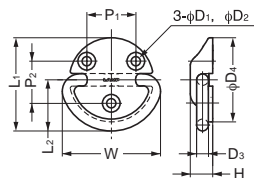

- Loop has constant torque, ideal for vibration or shock application.
- Suitable for marine, RV or freight applications.

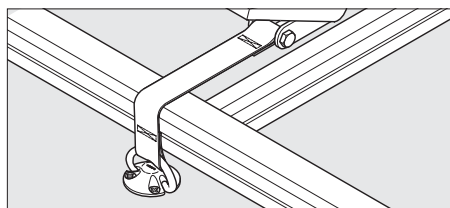

Item Code	Item Name	Material (*)	Finish	L <sub>1</sub>	L <sub>2</sub>	W	P <sub>1</sub>	P <sub>2</sub>	H	D <sub>1</sub>	D <sub>2</sub>	D <sub>3</sub>	D <sub>4</sub>	Load Capacity	Weight	Box	Carton	
110-012-542	EY-R50	Stainless Steel (SCS14)	Mirror	54	30	56.5	28	24	14.5	5.5	10.4	7.5	48	4900N	500kgf	116g	10pcs	120pcs
110-012-543	EY-R60	Stainless Steel (SCS14)	Mirror	66.5	36.5	70	35	30	16	6.6	12.6	8.5	60	7840N	800kgf	202g	10pcs	60pcs
110-012-544	EY-R80	Stainless Steel (SCS14)	Mirror	88.5	48.5	94	45	40	19	9	17.3	11	80	11760N	1200kgf	431g	5pcs	30pcs

(\*) SCS14 is similar to SUS316

# SWING HOOK

TEST LOAD CAPACITY 50 kgf STAINLESS 304 STEEL

# XL-JSF40TT



- Vertical swivel allows for under mount applications.

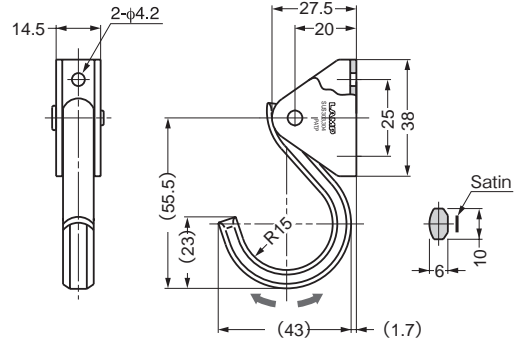

Item Code	Item Name	Material	Finish	Load Capacity	Weight	Box	Carton
110-020-011	XL-JSF40TT	Hook : Stainless Steel (SUS303), bracket : Stainless Steel (SUS304)	Mirror and Satin Combination	490N 50kgf	70g	20pcs	120pcs

# SWING HOOK

RoHS TEST LOAD CAPACITY 5.6-6.7 kgf STAINLESS 304 STEEL UC



- Vertical swivel allows for under mount applications.

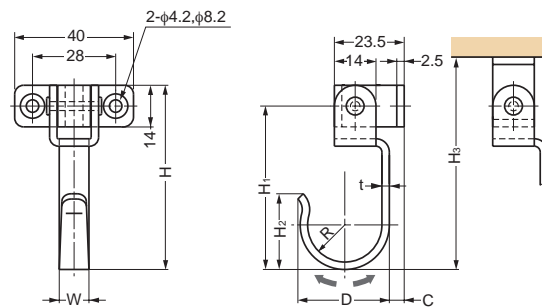

Item Code	Item Name	Material	Finish	W	D	H	H <sub>1</sub>	H <sub>2</sub>	H <sub>3</sub>	C	R	t	Load Capacity	Weight	Box	Carton
110-020-003	UC-048	Stainless Steel (SUS304)	Polished	9	(24.9)	55	48	(21.4)	64.5	6.5	10	2	54.9N 5.6kgf	37g	40pcs	400pcs
110-020-002	UC-055	Stainless Steel (SUS304)	Polished	10	(30.8)	62	55	(25.5)	71.5	5	12.5	2.5	65.7N 6.7kgf	45g	25pcs	250pcs

# SWING HOOK

RoHS TEST LOAD CAPACITY 6.7-8.9 kgf STAINLESS 304 STEEL UJ



- Rotates 360° and swivels 180°.
- Can be mounted in various directions.

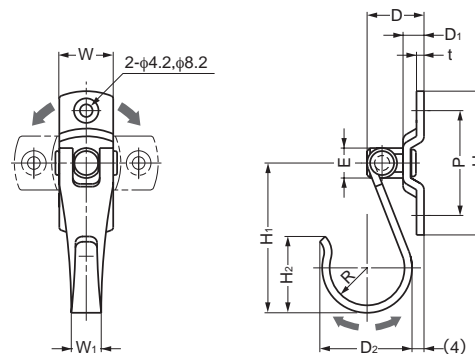

Item Code	Item Name	Material	Finish	W	W <sub>1</sub>	D	D <sub>1</sub>	D <sub>2</sub>	H	H <sub>1</sub>	H <sub>2</sub>	P	E	R	t	Load Capacity	Weight	Box	Carton
110-020-001	UJ-040	Stainless Steel (SUS304)	Polished	16	(9)	16.5	5.5	(24.9)	42	40	(21.4)	30	φ9	10	2	65.7N 6.7kgf	27g	50pcs	500pcs
110-020-000	UJ-050	Stainless Steel (SUS304)	Polished	18	(10)	19	7	(30.8)	48	50	(25.5)	35	φ10	12.5	2.5	87.2N 8.9kgf	45g	30pcs	300pcs



# ROTATING / SWING HOOK



**RF-U50**



- Rotates 360° and swings 180°.
- Can be mounted in various directions.

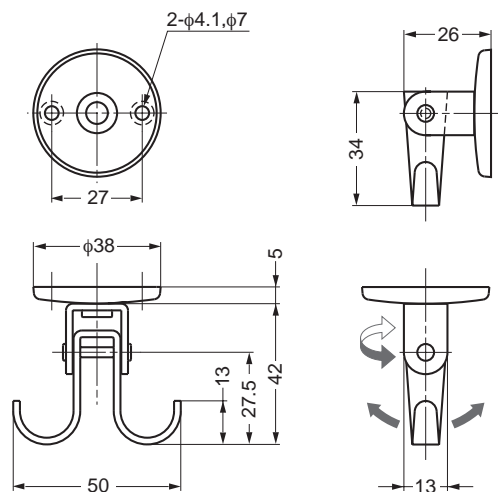
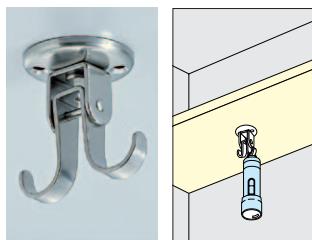

Item Code	Item Name	Material	Finish	Load Capacity	Weight	Box	Carton
110-020-007	RF-U50	Stainless Steel (SUS304)	Satin	59.8N / 6.1kgf	40g	25pcs	250pcs

# ROTATING HOOK



**RF-50**



- Rotates 360°.
- Can be mounted in various directions.

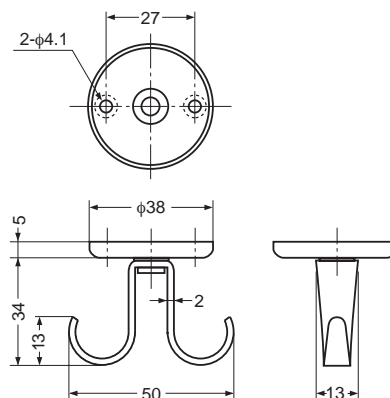
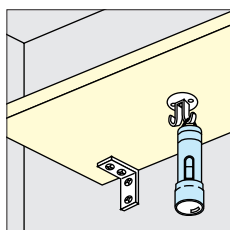

Item Code	Item Name	Material	Finish	Load Capacity	Weight	Box	Carton
110-020-082	RF-50S	Stainless Steel (SUS304)	Satin	29.4N / 3kgf	33g	25pcs	500pcs

# RECESSED HOOK



NF-R64



- Hook is spring loaded to retract.
- Ideal for vibration or shock application.
- Panel Thickness:  
Wood: Minimum 25 mm  
Sheet metal: 0.8 ~ 1.6 mm  
\*With optional bracket NF-50.

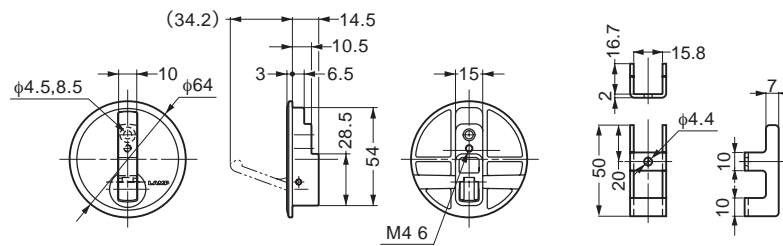

Bracket NF-50 (Option)

■ Metal sheet

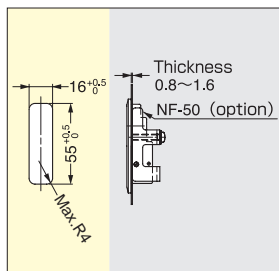

■ Wood (25~29mm)

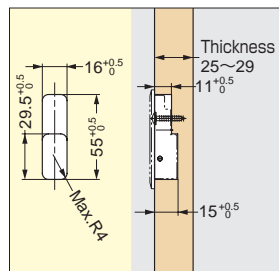

■ Wood (30mm~)

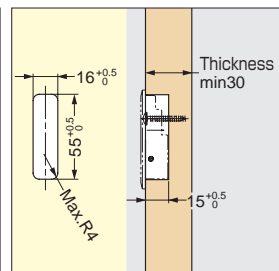

■ Bracket NF-50 (Option)



■ Screw Size

M4×20 (Stainless Steel)

Item Code	Item Name	Material	Finish	Weight	Box	Carton
110-020-021	NF-50	Steel	Zinc Chromate	22g	20pcs	400pcs

Item Code	Item Name	Material	Finish	Load Capacity	Weight	Box	Carton
110-020-068	NF-R64	Zinc Alloy	Chrome	196N	20kgf	90g	10pcs / 120pcs

# RECESSED HOOK



NF-60



- Hook is spring loaded to retract.
- Ideal for vibration or shock applications.
- Panel Thickness:  
Wood: Min. 20 mm  
Sheet metal: 0.8 ~ 1.6 mm  
\*With optional bracket NF-50.

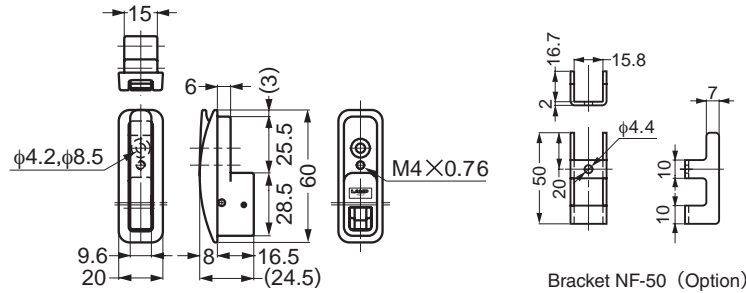

■ Metal sheet

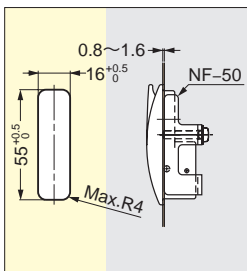

■ Wood (20~29mm)

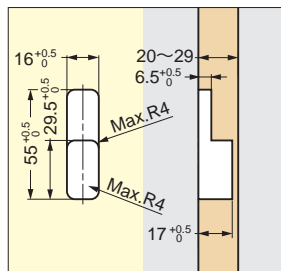

■ Wood (30mm~)

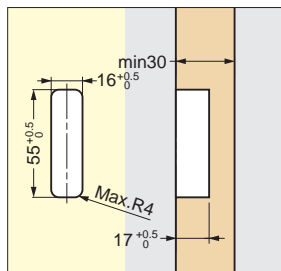

■ Bracket NF-50 (Option)



■ Screw Size

M4x20 (Stainless Steel)

Item Code	Item Name	Material	Finish	Weight	Box	Carton
110-020-021	NF-50	Steel	Zinc Chromate	22g	20pcs	400pcs

Item Code	Item Name	Material	Finish	Load Capacity	Weight	Box	Carton
110-020-067	NF-60	Aluminum Alloy	Dark Grey	196N	20kgf	31g	10pcs 200pcs

# HOOK

# WB-901145

- Surface mount. Easy installation. Stylish design with cap cover.

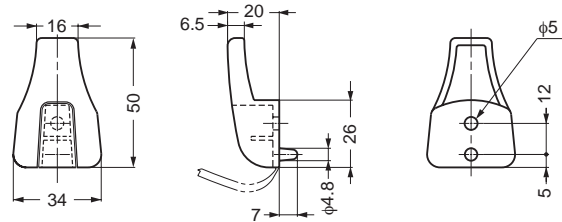

Item Code	Item Name	Material	Color	Weight
110-020-215	WB-901145	Polypropylene	Black	7g

# HOOK

# WB-901146

- Surface mount. Easy installation. Stylish design with cap cover.

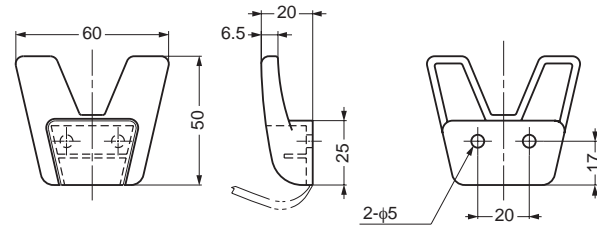

Item Code	Item Name	Material	Color	Weight
110-020-216	WB-901146	Polypropylene	Black	10g

# FOLDING BRACKET (W/STOPPER)



**BOS**



- Folding bracket with locking bracket.
- Slide the locking bracket to lock / unlock in open position.

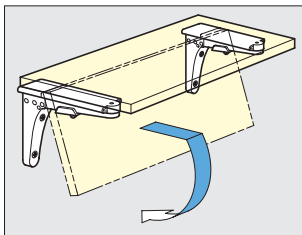
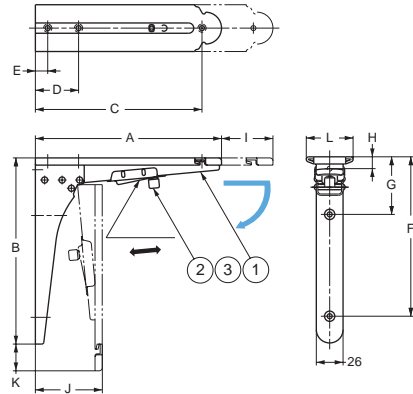

No.	Part Name	Material	Finish
①	Body	Stainless Steel (SUS304)	Satin
②	Knob	Brass	Nickel
③	Cover	NBR	Black

Item Code	Item Name	A	B	C	D	E	F	G	H	I	J	K	L	Load Capacity	Weight	Box	Carton	
120-030-111	BOS-180	181	181	162	42	12	155	56	11.5	50	65	26	45.5	392N	40kgf	476g	1pcs	20pcs
120-030-090	BOS-240	240	250	215	80	25	220	70	15	64	81	29	49	325N	33kgf	770g	1pcs	20pcs

# BRACKET



**BY**

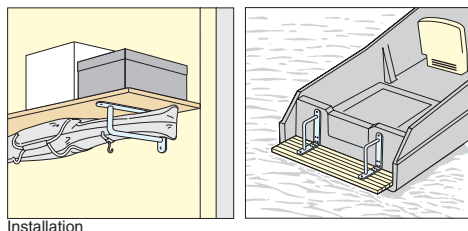
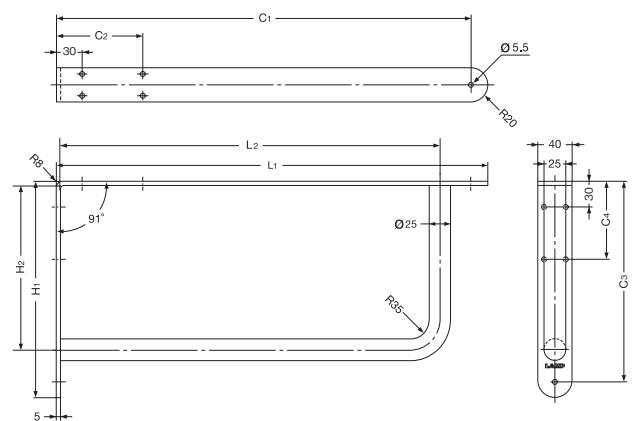

Installation

Item Code	Item Name	L1	L2	H1	H2	C1	C2	C3	C4	Holes
120-039-292	BY-300	300	240	150	90	280	100	130	-	8
120-039-293	BY-400	400	340	200	140	380	120	180	90	10
120-039-294	BY-500	500	440	250	190	480	160	230	90	10

Item Code	Item Name	Material	Finish	Load Capacity	Weight	Box	Carton
120-039-292	BY-300	Stainless Steel (SUS304)	Mirror	490N	50kgf	1,100g	2pcs
120-039-293	BY-400	Stainless Steel (SUS304)	Mirror	490N	50kgf	1,400g	2pcs
120-039-294	BY-500	Stainless Steel (SUS304)	Mirror	490N	50kgf	1,800g	2pcs

# SPRING LOADED BRACKET



# GTS-300

- Spring loaded for lift assist feature.
- Pull the knob to fold down.



### Installation

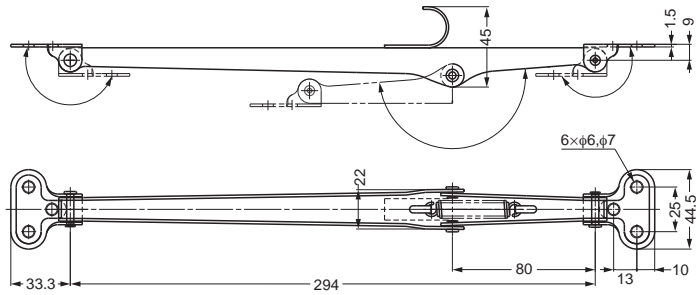
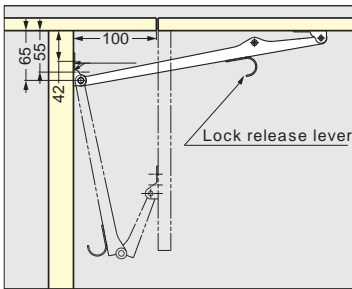

Item Code	Item Name	Material	Finish	Load Capacity	Panel Size		Weight	Box	Carton
					Depth	Width			
120-109-116	GTS-300	Stainless Steel(SUS304)	Satin	3kgf/1pc	Max.450mm/1pc	Max.300mm/1pc	190g	12pcs	96pcs
				6kgf/2pcs	Max.450mm/2pcs	Max.600mm/2pcs			

# FOLDING BRACKET



# BTO

- Folding bracket with manual lock lever.
- Slide the lock lever to lock / unlock in open position.
- Bracket with hinge function in one unit.
- Supplied with white painted screws.

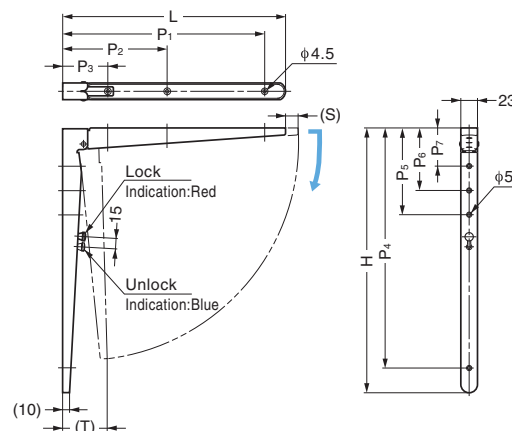
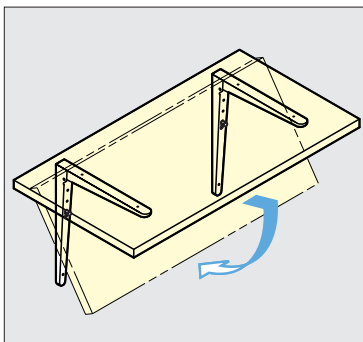

Item Code	Item Name	Material	Finish	H	L	P <sub>1</sub>	P <sub>2</sub>	P <sub>3</sub>	P <sub>4</sub>	P <sub>5</sub>	P <sub>6</sub>	P <sub>7</sub>	S	T	Load Capacity	Weight	Box	Carton	
120-014-937	BTO-300S	Stainless Steel (SUS304)	Satin	300	241	211	-	61	270	80	50	-	15	57	400N	40.8kgf	510g	2pcs	20pcs
120-030-091	BTO-300W	Steel	White	300	241	211	-	61	270	80	50	-	15	57	400N	40.8kgf	510g	2pcs	20pcs

# FOLDING BRACKET

LOAD CAPACITY  
150 kgf

NSF  
COMPONENT

NO SCREW

STAINLESS  
304  
STEEL

# EB-303/EP

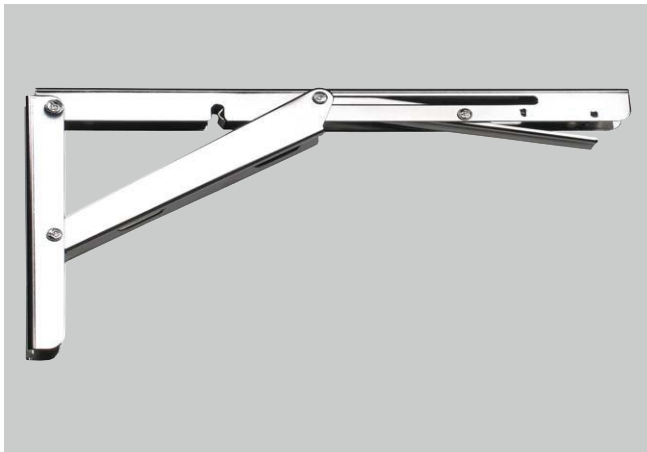

- Automatically locks when flap is in opened position.
- Press lever to release the lock.
- Bracket with hinge function in one unit.

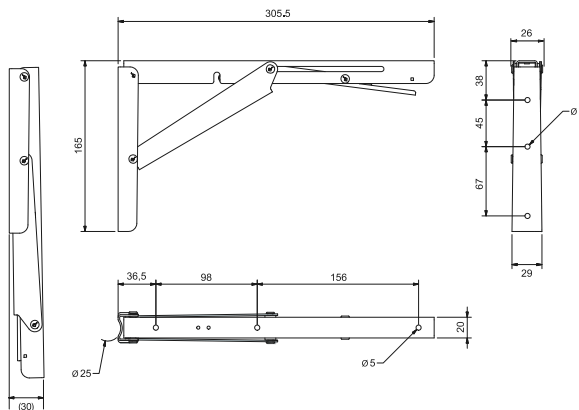

Item Code	Item Name	Material	Finish	Load Capacity	Weight	Box
120-018-226	EB-303/EP	Stainless Steel (SUS304)	Mirror	1,470N	150kgf	25pcs

# FOLDING BRACKET

LOAD CAPACITY  
35-80 kg

NO SCREW

ALUMINIUM

# 388



- Automatically locks when flap is in opened position.
- Press lever to release the lock.
- For panel thickness 15~35mm
- Required Quantity:
  - Width up to 600mm...1pc
  - Width 600~1300mm...2pcs

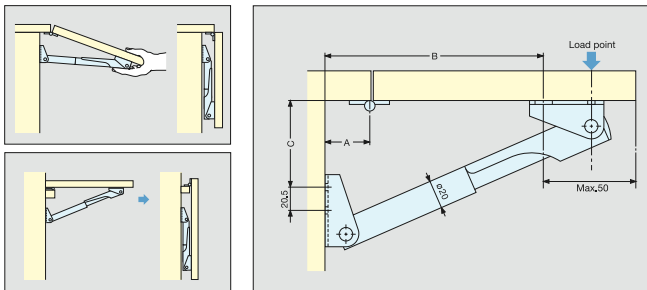
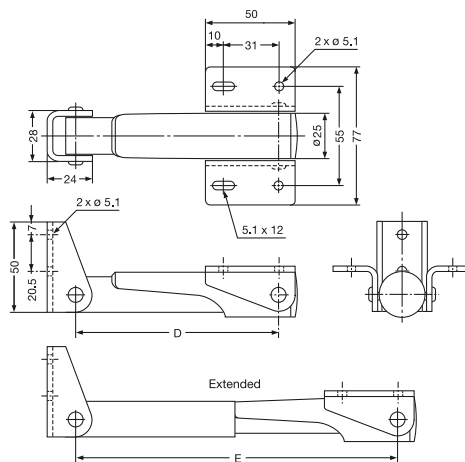

Installation example for 38820-25

Item Code	Item Name	Material	Finish	A	B	C	D	E	Load Capacity	Weight	Box	Carton
120-105-060	38820-25	Aluminium	Anodized	25 ~ 30	161	15	114	180	343N	35kgf	5pcs	50pcs
120-105-061	38830-25	Aluminium	Anodized	25 ~ 39	252	45	168	275.9	539N	55kgf		
120-105-062	38845-25	Aluminium	Anodized	25 ~ 50	402	87	258.5	430.8	588N	60kgf		266g
120-105-063	38860-25	Aluminium	Anodized	25 ~ 40	549	137	368.5	585.8	784N	80kgf		342g

BRACKET

TEST LOAD CAPACITY 15-82.5 kg NSF COMPONENT STAINLESS STEEL STAINLESS 304 STEEL

BT, BTK

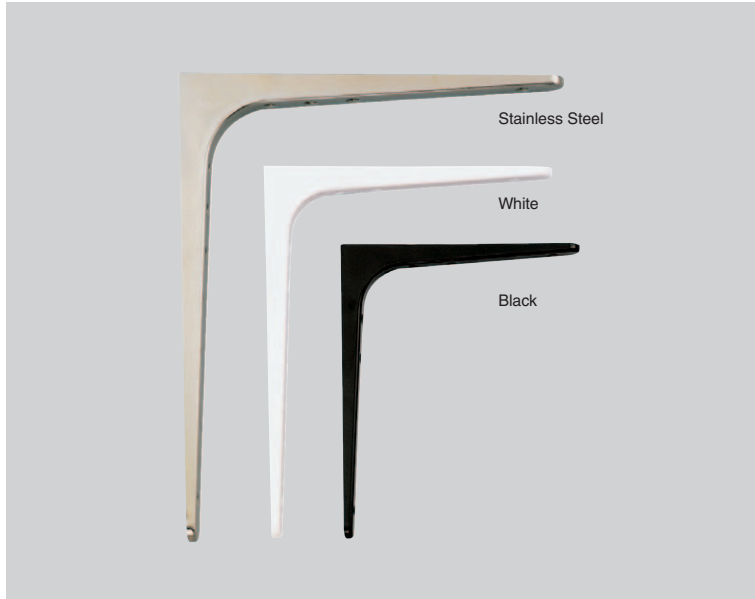

- Stainless steel (satin finish) or steel (white or black) available.
- Stainless steel is SUS304.

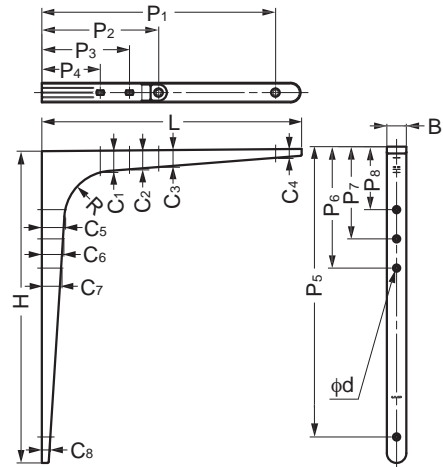

Item Code	Item Name	Material	Finish	H	L	B	P1	P2	P3	P4	P5	P6	P7	P8	Load Capacity	Box	Carton	
120-030-078	BT-85	Stainless Steel	Satin	86	69	15	58	27	-	-	75	26	-	-	147N	15kgf	20pcs	240pcs
120-030-093	BTK-85W	Steel	White	86	69	15	58	27	-	-	75	26	-	-	147N	15kgf	20pcs	240pcs
120-030-172	BTK-85B	Steel	Black	86	69	15	58	27	-	-	75	26	-	-	147N	15kgf	20pcs	240pcs
120-030-079	BT-120	Stainless Steel	Satin	120	100	15	85	43	-	-	106	42	-	-	196N	20kgf	20pcs	100pcs
120-030-094	BTK-120W	Steel	White	120	100	15	85	43	-	-	106	42	-	-	196N	20kgf	20pcs	100pcs
120-030-173	BTK-120B	Steel	Black	120	100	15	85	43	-	-	106	42	-	-	196N	20kgf	20pcs	100pcs
120-030-080	BT-180	Stainless Steel	Satin	180.5	148.5	15	131	71	50	-	162.5	72.5	51.5	-	245N	25kgf	20pcs	-
120-030-095	BTK-180W	Steel	White	180.5	148.5	15	131	71	50	-	162.5	72.5	51.5	-	245N	25kgf	20pcs	-
120-030-174	BTK-180B	Steel	Black	180.5	148.5	15	131	71	50	-	162.5	72.5	51.5	-	245N	25kgf	20pcs	-
120-030-081	BT-240	Stainless Steel	Satin	240	199	18	176	91	59	-	217	92	60	-	274.4N	28kgf	10pcs	-
120-030-096	BTK-240W	Steel	White	240	199	18	176	91	59	-	217	92	60	-	274.4N	28kgf	10pcs	-
120-030-175	BTK-240B	Steel	Black	240	199	18	176	91	59	-	217	92	60	-	274.4N	28kgf	10pcs	-
120-030-082	BT-300	Stainless Steel	Satin	301	238.5	20	206.5	92.5	60.5	-	269	95	63	-	343N	35kgf	10pcs	-
120-030-097	BTK-300W	Steel	White	301	238.5	20	206.5	92.5	60.5	-	269	95	63	-	343N	35kgf	10pcs	-
120-030-176	BTK-300B	Steel	Black	301	238.5	20	206.5	92.5	60.5	-	269	95	63	-	343N	35kgf	10pcs	-
120-030-083	BT-380	Stainless Steel	Satin	378	318	23	285	145	110	75	345	145	110	75	637N	65kgf	10pcs	40pcs
120-030-085	BTK-380W	Steel	White	378	318	23	285	145	110	75	345	145	110	75	637N	65kgf	10pcs	40pcs
120-030-177	BTK-380B	Steel	Black	378	318	23	285	145	110	75	345	145	110	75	637N	65kgf	10pcs	40pcs
120-030-155	BT-480	Stainless Steel	Satin	480	400	30	360	180	135	90	440	180	135	90	808.5N	82.5kgf	6pcs	-
120-030-156	BTK-480W	Steel	White	480	400	30	360	180	135	90	440	180	135	90	808.5N	82.5kgf	6pcs	-
120-030-178	BTK-480B	Steel	Black	480	400	30	360	180	135	90	400	180	135	90	808.5N	82.5kgf	6pcs	-

Item Code	Item Name	d	Holes	Weight	C1	C2	C3	C4	C5	C6	C7	C8	R
120-030-078	BT-85	4	4	40g	-		(9)	(5)	-	-	(12)	(5)	(25)
120-030-093	BTK-85W	4	4	40g	-		(9)	(5)	-	-	(12)	(5)	(25)
120-030-172	BTK-85B	4	4	40g	-		(9)	(5)	-	-	(12)	(5)	(25)
120-030-079	BT-120	4	4	60g	-		(10)	(5)	-	-	(13)	(5)	(25)
120-030-094	BTK-120W	4	4	60g	-		(10)	(5)	-	-	(13)	(5)	(25)
120-030-173	BTK-120B	4	4	60g	-		(10)	(5)	-	-	(13)	(5)	(25)
120-030-080	BT-180	4	6	110g	-	(14)	(12)	(5)	-	(15)	(13)	(5)	(30)
120-030-095	BTK-180W	4	6	110g	-	(14)	(12)	(5)	-	(15)	(13)	(5)	(30)
120-030-174	BTK-180B	4	6	110g	-	(14)	(12)	(5)	-	(15)	(13)	(5)	(30)
120-030-081	BT-240	4	6	200g	-	(16)	(13)	(8)	-	(16)	(14)	(7.5)	(35)
120-030-096	BTK-240W	4	6	200g	-	(16)	(13)	(8)	-	(16)	(14)	(7.5)	(35)
120-030-175	BTK-240B	4	6	200g	-	(16)	(13)	(8)	-	(16)	(14)	(7.5)	(35)
120-030-082	BT-300	4	6	310g	-	(19.5)	(17)	(8)	-	(19)	(17.5)	(9)	(35)
120-030-097	BTK-300W	4	6	310g	-	(19.5)	(17)	(8)	-	(19)	(17.5)	(9)	(35)
120-030-176	BTK-300B	4	6	310g	-	(19.5)	(17)	(8)	-	(19)	(17.5)	(9)	(35)
120-030-083	BT-380	5	8	470g	(22.5)	(20)	(18)	(8.5)	(25)	(20)	(18)	(10)	(50)
120-030-085	BTK-380W	5	8	470g	(22.5)	(20)	(18)	(8.5)	(25)	(20)	(18)	(10)	(50)
120-030-177	BTK-380B	5	8	470g	(22.5)	(20)	(18)	(8.5)	(25)	(20)	(18)	(10)	(50)
120-030-155	BT-480	5.5	8	1,100g	(35)	(30)	(27)	(14)	(37)	(33)	(30)	(13)	(70)
120-030-156	BTK-480W	5.5	8	1,100g	(35)	(30)	(27)	(14)	(37)	(33)	(30)	(13)	(70)
120-030-178	BTK-480B	5.5	8	1,100g	(35)	(30)	(27)	(14)	(37)	(33)	(30)	(13)	(70)

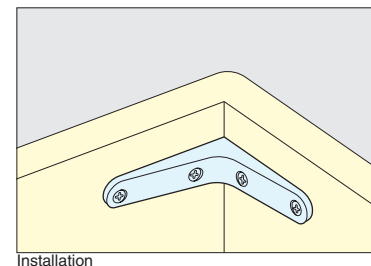
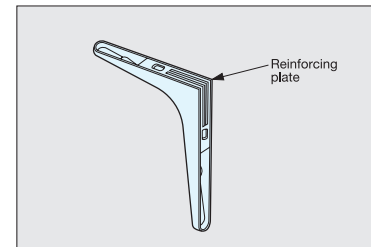

Installation



# ANGLE BRACKET



# XL-SA01



- Stainless steel bracket with soft and sleek design.

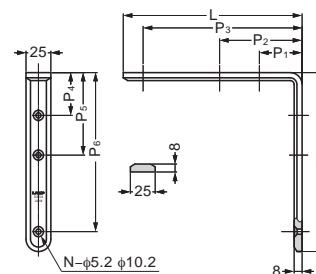

Item Code	Item Name	Material	Finish	L	H	P <sub>1</sub>	P <sub>2</sub>	P <sub>3</sub>	P <sub>4</sub>	P <sub>5</sub>	P <sub>6</sub>	N	Load Capacity/pc	Weight	Box	Carton	
120-030-303	XL-SA01-120S	Stainless Steel (SUS304)	Satin	120	120	38	—	100	38	—	100	4	226N	23kgf	312g	8pcs	40pcs
120-030-307	XL-SA01-120M	Stainless Steel (SUS304)	Mirror	120	120	38	—	100	38	—	100	4	226N	23kgf	312g	8pcs	40pcs
120-030-304	XL-SA01-150S	Stainless Steel (SUS304)	Satin	150	150	43	—	130	43	—	130	4	177N	18kgf	400g	6pcs	30pcs
120-030-308	XL-SA01-150M	Stainless Steel (SUS304)	Mirror	150	150	43	—	130	43	—	130	4	177N	18kgf	400g	6pcs	30pcs
120-030-305	XL-SA01-180S	Stainless Steel (SUS304)	Satin	180	180	43	83	160	43	83	160	6	137N	14kgf	483g	6pcs	30pcs
120-030-309	XL-SA01-180M	Stainless Steel (SUS304)	Mirror	180	180	43	83	160	43	83	160	6	137N	14kgf	483g	6pcs	30pcs
120-030-306	XL-SA01-240S	Stainless Steel (SUS304)	Satin	240	240	43	83	220	43	83	220	6	118N	12kgf	660g	4pcs	20pcs
120-030-310	XL-SA01-240M	Stainless Steel (SUS304)	Mirror	240	240	43	83	220	43	83	220	6	118N	12kgf	660g	4pcs	20pcs

# ANGLE BRACKET



# SU-A

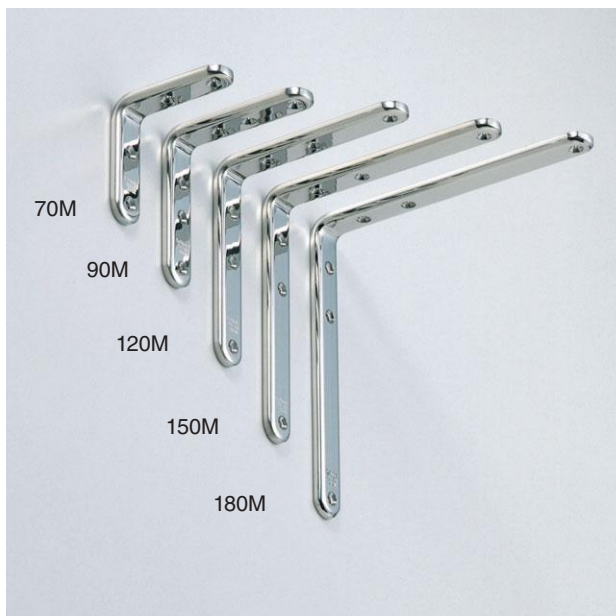

- Stainless steel angle bracket for applications where corrosion is an issue.

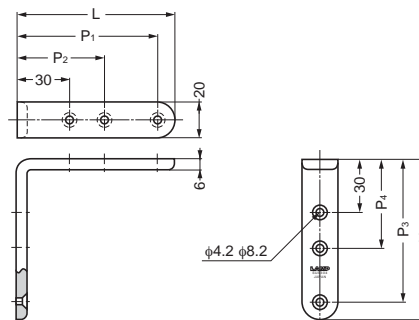

Item Code	Item Name	Material	Finish	H	L	P <sub>1</sub>	P <sub>2</sub>	P <sub>3</sub>	P <sub>4</sub>	Holes	Load Capacity	Weight	Box	Carton	
120-030-180	SU-A70M	Stainless Steel (SUS304)	Mirror	70	70	—	60	—	60	4pcs	235.2N	24kgf	107g	10pcs	100pcs
120-030-181	SU-A90M	Stainless Steel (SUS304)	Mirror	90	90	80	50	80	50	6pcs	166.6N	17kgf	140g	10pcs	100pcs
120-030-182	SU-A120M	Stainless Steel (SUS304)	Mirror	120	120	110	60	110	60	6pcs	127.4N	13kgf	194g	8pcs	80pcs
120-030-183	SU-A150M	Stainless Steel (SUS304)	Mirror	150	150	140	60	140	60	6pcs	98 N	10kgf	248g	6pcs	60pcs
120-030-179	SU-A180M	Stainless Steel (SUS304)	Mirror	180	180	170	60	170	60	6pcs	88.2N	9kgf	302g	6pcs	30pcs

# ANGLE BRACKET



SU-B

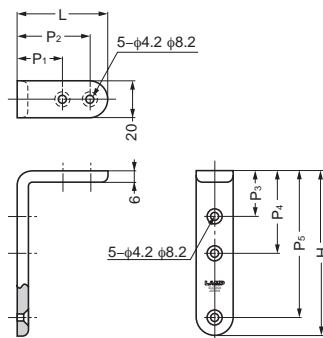

• Stainless steel angle bracket for applications where corrosion is an issue.

Item Code	Item Name	Material	Finish	H	L	P <sub>1</sub>	P <sub>2</sub>	P <sub>3</sub>	P <sub>4</sub>	P <sub>5</sub>	Holes	Load Capacity	Weight	Box	Carton	
120-030-184	SU-B50M	Stainless Steel (SUS304)	Mirror	90	50	25	40	25	45	80	5pcs	127.4N	13kgf	106g	10pcs	100pcs
120-030-185	SU-B65M	Stainless Steel (SUS304)	Mirror	120	65	30	55	30	60	110	5pcs	127.4N	13kgf	145g	10pcs	100pcs
120-030-186	SU-B80M	Stainless Steel (SUS304)	Mirror	150	80	30	70	30	60	140	5pcs	98N	10kgf	186g	8pcs	80pcs

# ANGLE BRACKET



SU

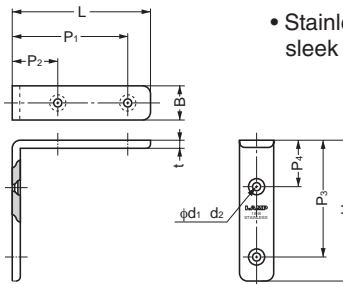
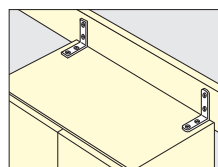

• Stainless steel bracket with soft and sleek design.

Item Code	Item Name	Material	Finish	L	B	H	P <sub>1</sub>	P <sub>2</sub>	P <sub>3</sub>	P <sub>4</sub>	t	d <sub>1</sub>	d <sub>2</sub>	Holes	Load Capacity	Weight	Box	Carton	
120-030-070	SU-30S	Stainless Steel (SUS304)	Satin	30	12	30	24	11	24	11	2.5	3.5	6.5	4pcs	58.8N	6kgf	11g	60pcs	960pcs
120-030-065	SU-30M	Stainless Steel (SUS304)	Mirror	30	12	30	24	11	24	11	2.5	3.5	6.5	4pcs	58.8N	6kgf	11g	60pcs	960pcs
120-030-071	SU-45S	Stainless Steel (SUS304)	Satin	45	13	45	37	17	37	17	3	3.5	6.5	4pcs	49N	5kgf	23g	50pcs	800pcs
120-030-066	SU-45M	Stainless Steel (SUS304)	Mirror	45	13	45	37	17	37	17	3	3.5	6.5	4pcs	49N	5kgf	23g	50pcs	800pcs
120-030-072	SU-60S	Stainless Steel (SUS304)	Satin	60	15	60	50	20	50	20	3	4	7.5	4pcs	39.2N	4kgf	36g	40pcs	640pcs
120-030-067	SU-60M	Stainless Steel (SUS304)	Mirror	60	15	60	50	20	50	20	3	4	7.5	4pcs	39.2N	4kgf	36g	40pcs	640pcs

# ANGLE BRACKET



SV

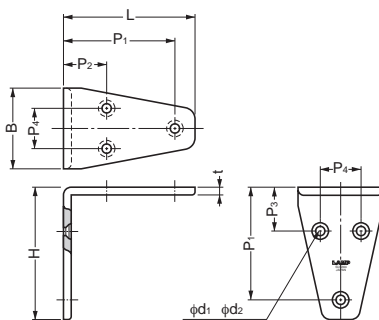

• Stainless steel angle bracket for applications where corrosion is an issue.

Item Code	Item Name	Material	Finish	L	H	P <sub>1</sub>	P <sub>2</sub>	P <sub>3</sub>	P <sub>4</sub>	B	t	d <sub>1</sub>	d <sub>2</sub>	Holes	Load Capacity	Weight	Box	Carton	
120-030-060	SV-40S	Stainless Steel (SUS304)	Satin	40	40	34	17	17	—	25	3	3.3	6.5	4pcs	78.4N	8kgf	29g	40pcs	640pcs
120-030-056	SV-40M	Stainless Steel (SUS304)	Mirror	40	40	34	17	17	—	25	3	3.3	6.5	4pcs	78.4N	8kgf	29g	40pcs	640pcs
120-030-061	SV-55S	Stainless Steel (SUS304)	Satin	55	55	47	18	18	17	36.5	3	3.8	7.5	6pcs	78.4N	8kgf	58g	20pcs	320pcs
120-030-057	SV-55M	Stainless Steel (SUS304)	Mirror	55	55	47	18	18	17	36.5	3	3.8	7.5	6pcs	78.4N	8kgf	58g	20pcs	320pcs
120-030-062	SV-80S	Stainless Steel (SUS304)	Satin	80	80	71	24	24	27	52	4	4.3	8.5	6pcs	137.2N	14kgf	162g	10pcs	120pcs
120-030-058	SV-80M	Stainless Steel (SUS304)	Mirror	80	80	71	24	24	27	52	4	4.3	8.5	6pcs	137.2N	14kgf	162g	10pcs	120pcs

# HEAVY DUTY SHELF STANDARD



# SPHL-1820



- Heavy duty shelf standard.
- Easy height adjustment for changing shelf level.
- Shelf support options: SPHL-25  
SPHL-30

### Surface mount

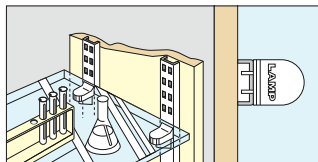

### Recessed mount

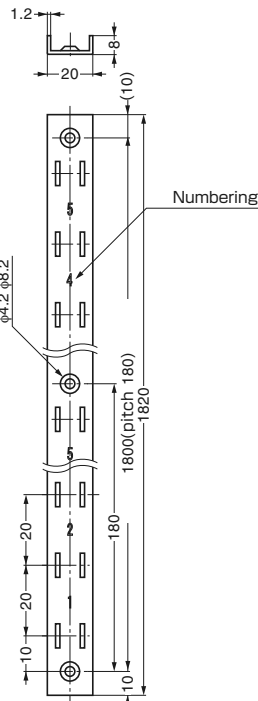
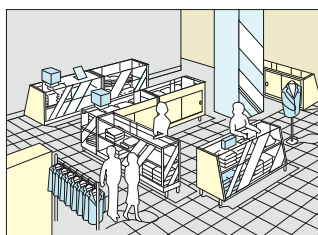
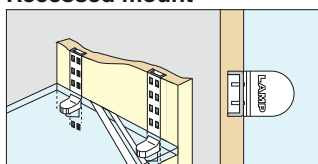

Item Code	Item Name	Material	Finish	Holes	Weight	Box
120-030-912	SPHL-1820	Stainless Steel (SUS304)	Satin	11	500g	30pcs

# SHELF SUPPORT



# SPHL-30



- Shelf support for SPHL-1820.
- Load capacity per shelf:  
4 supports

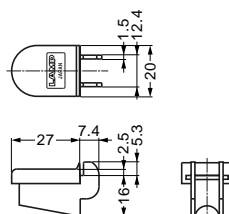

Item Code	Item Name	Material	Finish	Load Capacity	Weight	Box	Carton
120-030-913	SPHL-30	Stainless Steel (SUS304)	Satin	1,470N	150kgf	12g	100pcs, 1,000pcs

# HEAVY DUTY SHELF SUPPORT



# SPHL-25



- Shelf support for SPHL-1820.
- Rubber pad prevents glass shelf from sliding.
- Shelf support is friction retention.
- Load capacity per shelf:  
4 supports

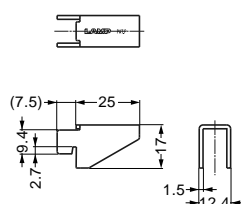

Item Code	Item Name	Material	Finish	Load Capacity	Weight	Box	Carton
120-030-914	SPHL-25	Stainless Steel (SUS304)	Satin	1,470N	150kgf	11g	200pcs, 1,200pcs

# SHELF STANDARD

- Easy height adjustment for changing shelf level.
- Option parts:  
SPH-5, SPH-15, SPH-20 (Shelf Supports)  
SP-18E (End Cap)

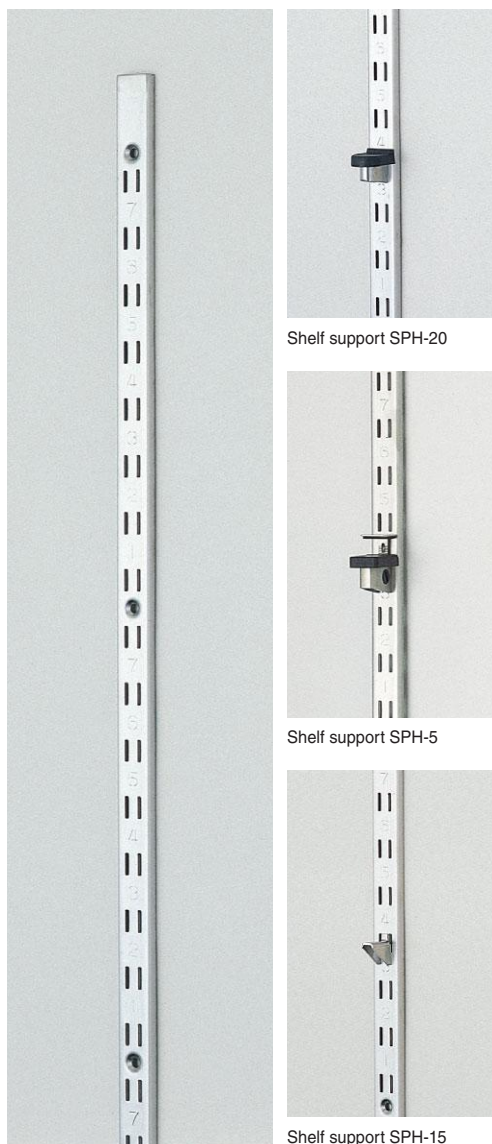

### Surface mount

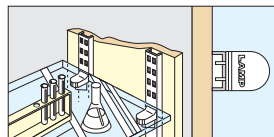

### Recessed mount

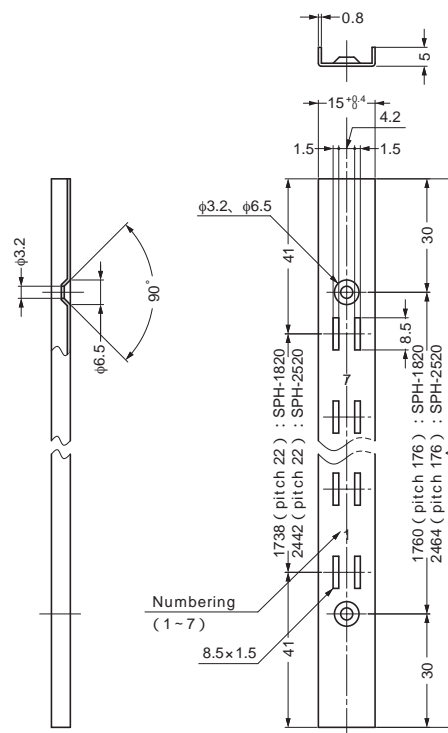
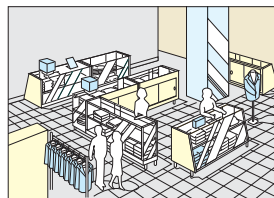
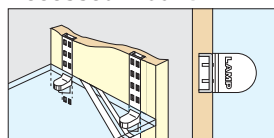

Item Code	Item Name	Material	Finish	A	Holes	Weight	Carton
120-030-673	SPH-1820	Stainless Steel (SUS304)	Satin	1,820	11	230g	80pcs
120-030-682	SPH-2520	Stainless Steel (SUS304)	Satin	2,524	15	330g	30pcs

# END CAP

# SP-18E



- End cover cap for SPH, SM, SP shelf standards.

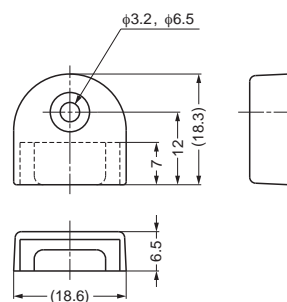

Item Code	Item Name	Material	Color	Box	Carton
120-030-214	SP-18E-BL	ABS	Black	500pcs	5,000pcs
120-030-215	SP-18E-WT	ABS	White	500pcs	5,000pcs

# SHELF SUPPORT



TEST

LOAD CAPACITY  
130 kgf

STAINLESS  
304  
STEEL

## SPH-20

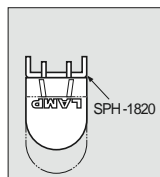
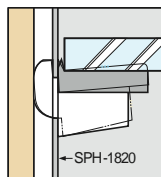

- Shelf support for SPH-1820.
- Shelf support is friction retention.
- Load capacity per shelf:  
4 supports

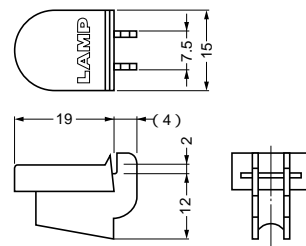
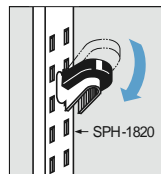

Item Code	Item Name	Material	Finish	Load Capacity	Weight	Box	Carton
120-041-375	SPH-20	Stainless Steel (SUS304)	Satin	1,280N 130kgf	4.5g	300pcs	3,000pcs

# SHELF SUPPORT (W/HOLDER)

TEST

LOAD CAPACITY  
130 kgf

STAINLESS  
304  
STEEL

## SPH-5

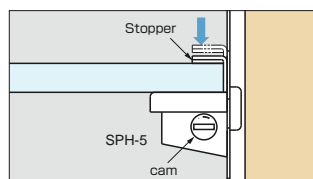

- Shelf support for SPH-1820.
- Shelf support is friction retention.
- Glass thickness:  
4 ~ 8mm thickness.
- Load capacity per shelf:  
4 supports

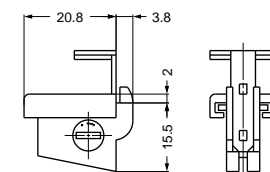
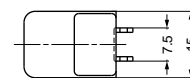

Item Code	Item Name	Material	Finish	Load Capacity	Weight	Box	Carton
120-041-374	SPH-5	Stainless Steel (SUS304)	Satin	1,280N 130kgf	8g	100pcs	1,000pcs

# SHELF SUPPORT



TEST

LOAD CAPACITY  
130 kgf

STAINLESS  
304  
STEEL

## SPH-15



- Shelf support for SPH-1820.
- Load capacity per shelf:  
4 supports

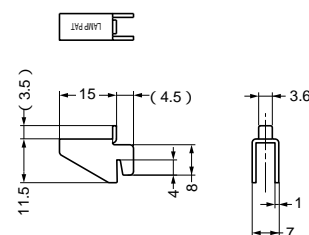

Item Code	Item Name	Material	Finish	Load Capacity	Weight	Box	Carton
120-030-665	SPH-15	Stainless Steel (SUS304)	Satin	1,280N 130kgf	2.6g	400pcs	4,000pcs

## SHELF STANDARD



**SP**

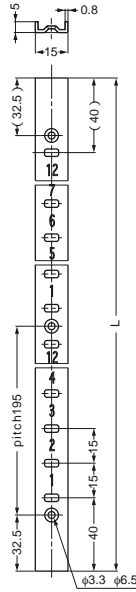

- Easy height adjustment for changing shelf level.
- Option parts :  
 SPB-15R, SPB-20, SPF-20,  
 SPF-20LC (Shelf Supports),  
 SPF-20A (Shelf Holder),  
 SP-35 (Hook),  
 SP-18E (End Cap).

Item Code	Item Name	Material	Finish/Color	L	Holes	Weight	Carton
120-030-685	SP-455	Stainless Steel (SUS304)	Satin	455	3	57g	60pcs
120-030-686	SP-650	Stainless Steel (SUS304)	Satin	650	4	81g	60pcs
120-030-687	SP-845	Stainless Steel (SUS304)	Satin	845	5	105g	60pcs
120-030-688	SP-1040	Stainless Steel (SUS304)	Satin	1040	6	129g	60pcs
120-030-827	SP-1820	Stainless Steel (SUS304)	Satin	1820	10	222g	60pcs
120-030-692	SP-1820WT	Stainless Steel (SUS430)	White	1820	10	222g	60pcs
120-030-668	SP-2600	Stainless Steel (SUS304)	Satin	2600	14	317g	30pcs
120-030-669	SPS-1820	Stainless Steel (SUS430)	Satin	1820	10	222g	60pcs
120-030-667	SPS-2600	Stainless Steel (SUS430)	Satin	2600	14	317g	30pcs

## SHELF HOOK

**LOAD CAPACITY**  
5 kgf

**SP-35**



### Installation

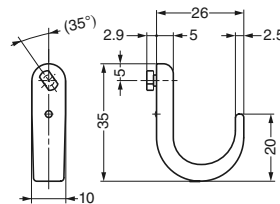

- Hook for SP.
- Can be used in vertical or horizontal applications.

Item Code	Item Name	Material	Finish	Load Capacity	Weight	Box	Carton
120-020-234	SP-35	Zinc Alloy	Nickel	49N / 5kgf	15.5g	150pcs	600pcs

## SHELF SUPPORT



**LOAD CAPACITY**  
100 kgf

**STAINLESS 304 STEEL**

**SPB-15R**



Push in to fix

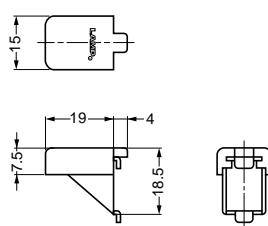

- Shelf support for SP.
- Shelf support is friction retention.
- Load capacity per shelf :  
4 supports.

Item Code	Item Name	Material	Finish	Load Capacity	Weight	Box	Carton
120-049-026	SPB-15R	Stainless Steel (SUS304)	Satin	980N / 100kgf	6g	300pcs	3,000pcs

## LEVELING CAP



LOAD CAPACITY  
80 kgf

STAINLESS  
304  
STEEL

## SPF-20LC



- Cap for SPF-20.
- Shelf level can be adjusted by flipping over the cap.
- Load capacity per shelf : 4 supports.

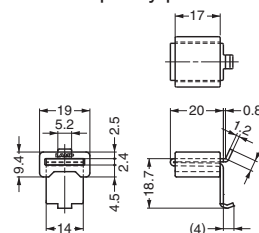

Item Code	Item Name	Material	Finish/Color	Load Capacity	Weight	Box	Carton
120-030-335	SPF-20LC	Stainless Steel (SUS304) /Silicone	Satin/Natural	785N 80kgf	9.5g	200pcs	2,000pcs

## SHELF SUPPORT

TEST

LOAD CAPACITY  
45 kgf

STAINLESS  
304  
STEEL

## SPB-20

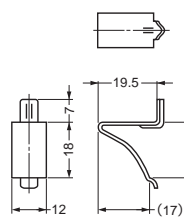
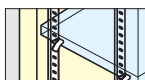

- Shelf support for SP-1820.
- Load capacity per shelf : 4 supports.

Item Code	Item Name	Specification	Material	Finish/Color	Load Capacity	Weight	Box	Carton
120-030-015	SPB-20	with protection tape	Stainless Steel (SUS304)	Satin	441N 45kgf	3.6g	300pcs	3,000pcs
120-031-474	SPB-20T	without protection tape	Stainless Steel (SUS304)	Satin	441N 45kgf	3.6g	300pcs	3,000pcs
120-030-693	SPB-20WT	without protection tape	Stainless Steel (SUS304)	White	441N 45kgf	3.6g	300pcs	3,000pcs

## SHELF SUPPORT

TEST

LOAD CAPACITY  
80 kgf

STAINLESS  
304  
STEEL

## SPF-20

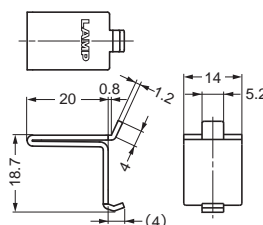
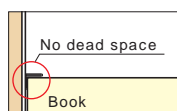

- Shelf support for SP-1820.
- Designed to eliminate dead space.
- Load capacity per shelf : 4 supports.

Item Code	Item Name	Spec	Material	Finish/Color	Load Capacity	Weight	Box	Carton
120-030-116	SPF-20	with protection tape	Stainless Steel (SUS304)	Satin	785N 80kgf	7g	300pcs	3,000pcs
120-030-117	SPF-20T	without protection tape	Stainless Steel (SUS304)	Satin	785N 80kgf	7g	300pcs	3,000pcs
120-030-684	SPF-20WT	without protection tape	Stainless Steel (SUS304)	White	785N 80kgf	7g	300pcs	3,000pcs

## SHELF HOLDER



## SPF-20A

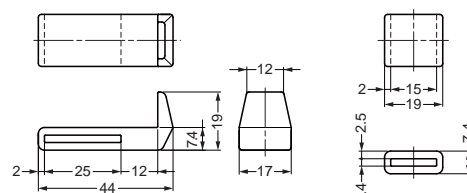

- Plastic holder to keep the shelfin position.
- Used together with SPF-20.
- Distance from center of front shelf support to front shelf edge is 19 ~ 30mm. (Adjustable)
- One each of front and back holder sold as set.

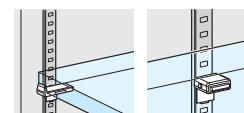

Item Code	Item Name	Material	Color	Weight	Box	Carton
120-040-548	SPF-20A	Polyethylene	White	4g	100set	2,500set

# SHELF STANDARD



**SM**

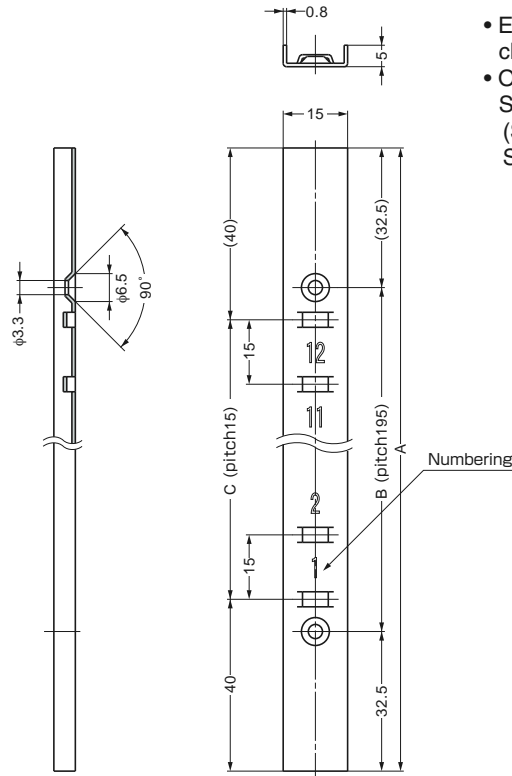

- Easy height adjustment for changing shelf level.
- Option parts:  
SMB-15R, SPM-20B, (Shelf support)  
SP-18E (End Cap)

Item Code	Item Name	A	B	C	Material	Finish	Holes	Weight	Carton
120-030-675	SM-1820	1820	1755	1740	Stainless Steel (SUS304)	Satin	10	245g	60pcs
120-030-846	SM-2600	2600	2535	2520	Stainless Steel (SUS304)	Satin	14	352g	30pcs

# SHELF SUPPORT



**SMB-15R**

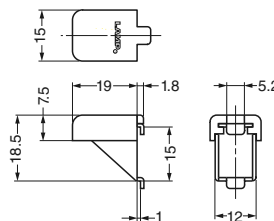

- Shelf support for SM-1820.
- Shelf support is friction retention.

Item Code	Item Name	Material	Finish	Load Capacity	Weight	Box	Carton
120-030-674	SMB-15R	Stainless Steel (SUS304)	Satin	883N	90kgf	6g	300pcs

# SHELF SUPPORT



**SPM-20B**

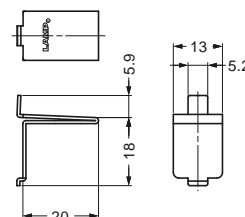
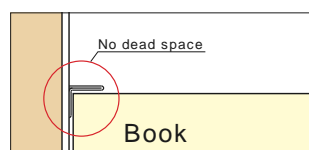

- Shelf support for SM-1820.
- Designed to eliminate dead space.
- Load capacity per shelf:  
4 supports

Item Code	Item Name	Material	Finish	Load Capacity	Weight	Box	Carton
120-030-915	SPM-20B	Stainless Steel (SUS304)	Satin	588N	60kgf	5g	300pcs



# SHELF STANDARD



**SPE**



■ SPE-FB20S + SPE-FC20

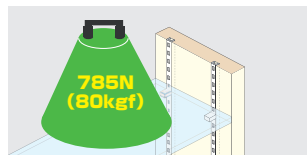
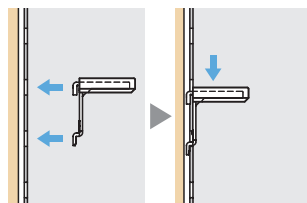
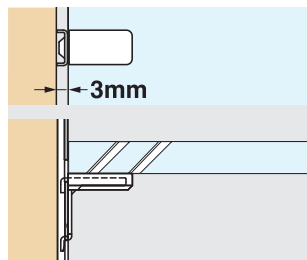
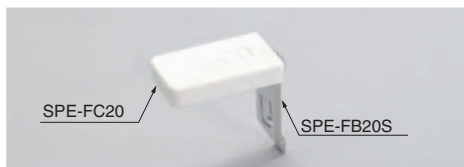

Load capacity per shelf : 4 supports

- Ultra thin. Easy height adjustment for changing shelf level. One touch installation.

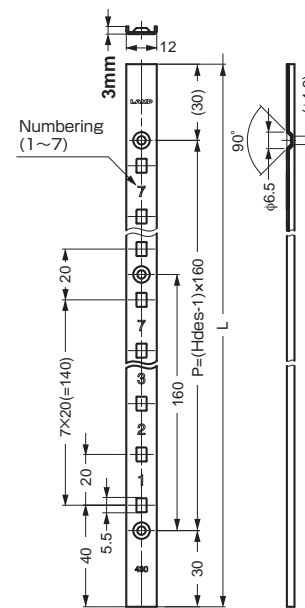

Item Code	Item Name	Material	Finish/Color	L	P	Holes
120-019-532	SPE-1820	Stainless Steel (SUS430)	Plain	1820	1760	12
120-020-757	SPE-1820WT	Stainless Steel (SUS430)	White	1820	1760	12
120-021-423	SPE-2620	Stainless Steel (SUS430)	Plain	2620	2560	17

# SHELF SUPPORT



**SPE-FB20**

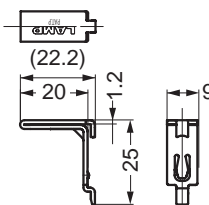
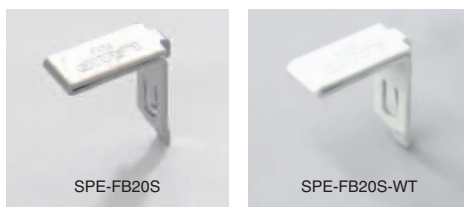

- One touch installation. Ultra thin.
- Load capacity per shelf : 4 supports

Item Code	Item Name	Material	Finish/Color	Load Capacity
120-020-903	SPE-FB20S	Stainless Steel (SUS430)	Polished	785N 80kgf
120-021-678	SPE-FB20S-WT	Stainless Steel (SUS430)	White	785N 80kgf

# LEVELING CAP



**SPE-FC20**

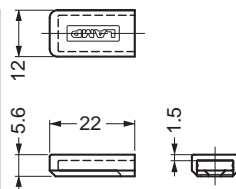

Item Code	Item Name	Material	Color
120-019-642	SPE-FC20	Synthetic Rubber	Light Grey

# END CAP



**AP-EC20**

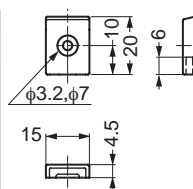

Item Code	Item Name	Material	Color
120-030-157	AP-EC20	ABS	Light Grey

# NARROW SHELF STANDARD



## SPN-1820

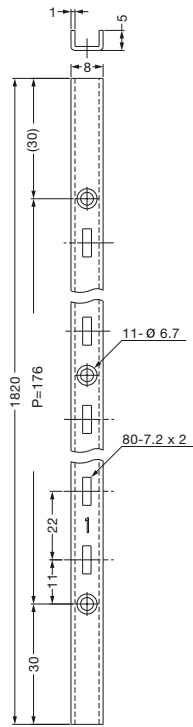

- Unique slim 8x5 profile.
- Easy to cut to desired length.
- Option parts:
  - SPN-15 (Shelf Support), SPN-17EC (End Cap)

Item Code	Item Name	Material	Finish	Holes	Weight	Box
120-017-129	SPN-1820	Stainless Steel (SUS430)	Satin	11	205g	60pcs

# SHELF SUPPORT



## SPN-15

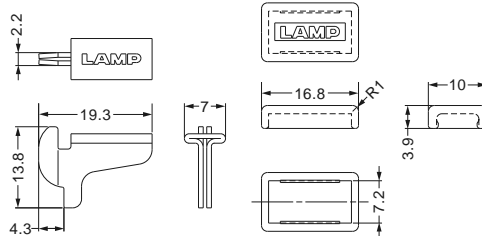

- Shelf support for SPN-1820.
- Cap SPN-15C sold separately.
- Load capacity per shelf : 4 supports.

Item Code	Item Name	Material	Color	Weight	Box	Carton	
120-017-693	SPN-15C	Elastomer	White	0.5g	400pcs	4,000pcs	
Item Code	Item Name	Material	Finish	Load Capacity	Weight	Box	Carton
120-017-692	SPN-15	Stainless Steel (SUS304)	Plain	785N 80kgf	2g	400pcs	2,000pcs

# END CAP



## SPN-17EC

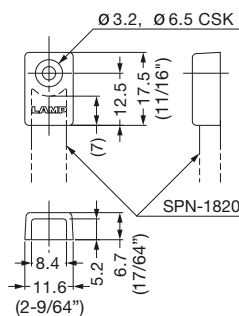

- Cap for SPN-1820.

Item Code	Item Name	Material	Color	Weight	Box	Carton
120-017-694	SPN-17EC	Polypropylene	White	0.9g	400pcs	4,000pcs

# SHELF STANDARD



# AP-DM, AP-DH



- Aluminum shelf standard.
- Easy to cut to desired length.
- Thin profile (3mm) suitable for surface mount.
- Screw hole located every 120mm.
- New slot shape to prevent shelf support from falling off.
- Special screw with silver finish available. (AP-SC3-16)

**Remark**

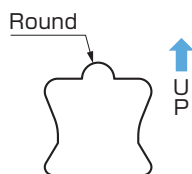

AP-DM

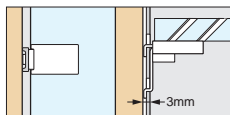

AP-DH

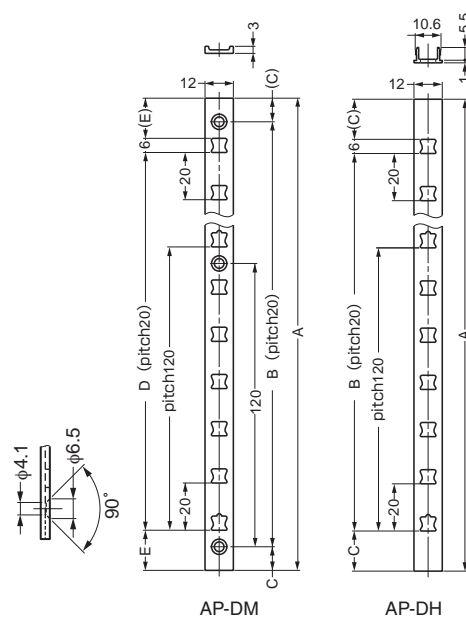
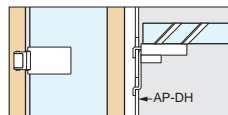

AP-DM

AP-DH

Item Code	Item Name	Spec	Material	Finish	A	B	C	D	E	Carton
120-030-086	AP-DM1820	Surface Mount	Aluminum Alloy	Matte Silver	1820	1800	10	1780	17	100pcs
120-016-209	AP-DM1820WT	Surface Mount	Aluminum Alloy	White	1820	1800	10	1780	17	100pcs
120-030-087	AP-DM2600	Surface Mount	Aluminum Alloy	Matte Silver	2600	2520	40	2500	47	60pcs
120-030-088	AP-DH1820	Mortise Mount	Aluminum Alloy	Matte Silver	1820	1780	17	—	—	100pcs
120-030-089	AP-DH2600	Mortise Mount	Aluminum Alloy	Matte Silver	2600	2500	47	—	—	60pcs

# SHELF SUPPORT



LOAD CAPACITY  
45 kgf



# AP-FB20

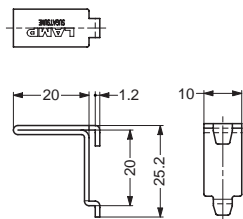

- Shelf support for AP-DM and AP-DH.
- Designed to eliminate dead space at bottom of bracket.

Item Code	Item Name	Material	Finish	Load Capacity	Box	Carton
120-030-158	AP-FB 20	Stainless Steel (SUS430)	Mirror	441N 45kgf	300pcs	3,000pcs

# SHELF SUPPORT CAP



# AP-FC20

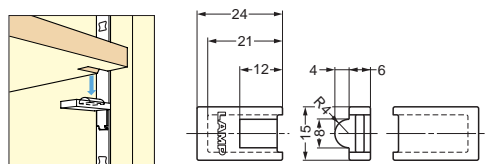

- Rubber cap for shelf support AP-FB20.
- Insert the cap with half round shape facing up, and cutout the shelf to prevent from sliding.

Item Code	Item Name	Material	Color	Box	Carton
120-030-159	AP-FC20	Synthetic Rubber	Light Grey	400pcs	4,000pcs

# END CAP



# AP-EC20

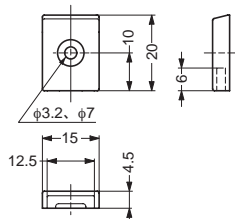

- End cap for AP-DM.

Item Code	Item Name	Material	Color	Box	Carton
120-030-157	AP-EC20	ABS	Light Grey	400pcs	4,000pcs



## TORQUE DAMPERS

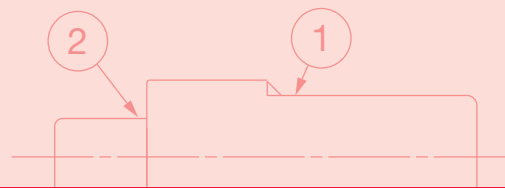
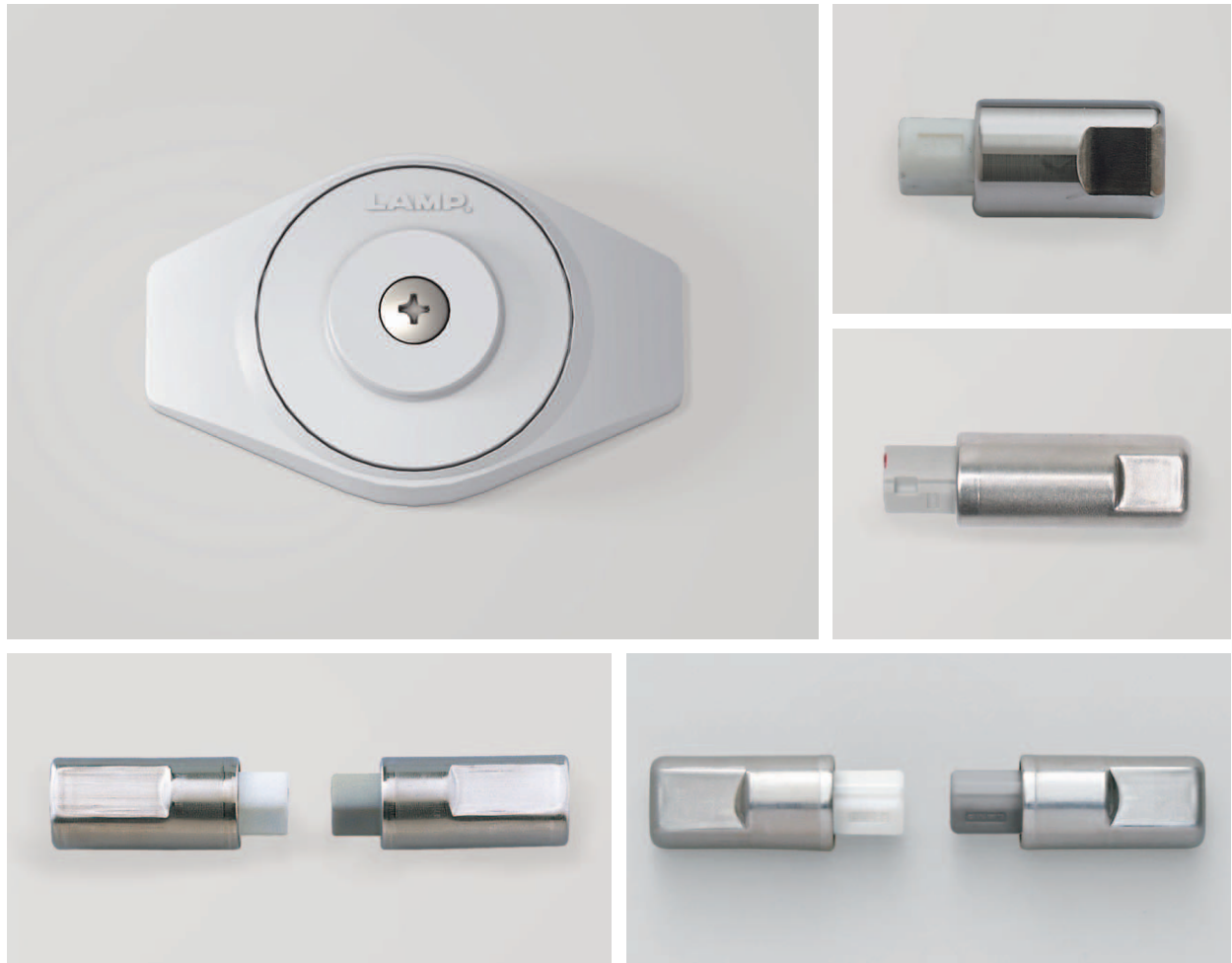

## TORQUE DAMPERS

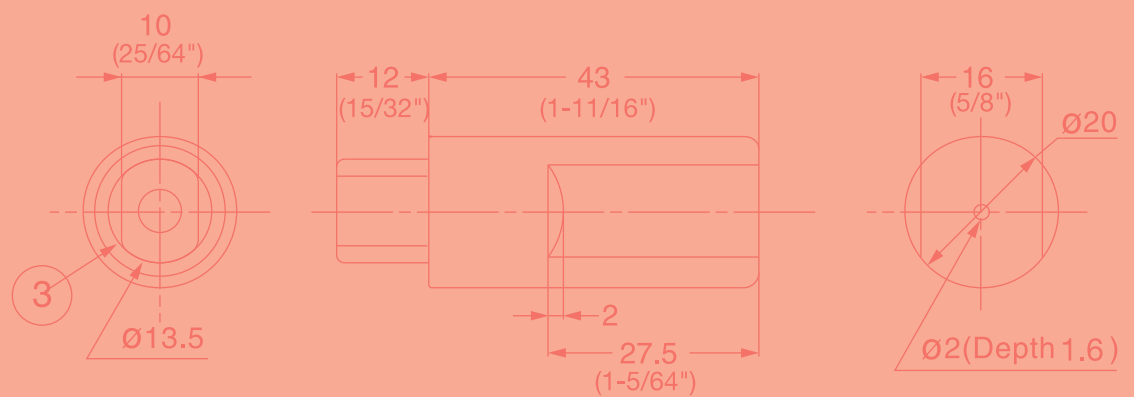



**DISK DAMPER**

Picture	Item Name	Size	Thickness	Damping direction	Torque	Page
	UDD-L	80 x 51.6mm	19.6mm		50 - 300N.cm	254
	UDD-R	80 x 51.6mm	19.6mm		50 - 300N.cm	254

**TORQUE DAMPER**

Picture	Item Name	Diameter	Length	Damping direction	Torque	Page
	UDH-A	20mm	55mm		150 - 400N.cm	255
	UDH-B	20mm	55mm		150 - 400N.cm	255
	UDH16N-A	16mm	51mm		170 - 300N.cm	256
	UDH16N-B	16mm	51mm		170 - 300N.cm	256
	UDH16-A	16mm	37mm		100 - 250N.cm	257
	UDH16-B	16mm	37mm		100 - 250N.cm	257
	UDH16S-A	16mm	37mm		100 - 250N.cm	258
	UDH16S-B	16mm	37mm		100 - 250N.cm	258
	UDH14-A	14mm	37mm		80 - 220N.cm	259
	UDH14-B	14mm	37mm		80 - 220N.cm	259

**TORQUE DAMPER**

Item Name	Torque (N.cm)	Torque range (N.cm)																Page		
		40	60	80	100	120	140	160	180	200	220	240	260	280	300	320	340		360	380
UDD-S	50 - 100		█	█	█															
UDD-M	100 - 200				█	█	█	█	█											
UDD-H	200 - 300								█	█	█	█	█							
UDH-M	150 - 250							█	█	█	█	█								
UDH-H	250 - 350											█	█	█	█	█				
UDH-G	300 - 400														█	█	█	█	█	
UDH16N-M	200 - 260										█	█	█							
UDH16N-H	240 - 300												█	█	█					
UDH16-M	100 - 170				█	█	█													
UDH16-H	150 - 250							█	█	█	█	█								
UDH16S-M	100 - 170				█	█	█													
UDH16S-H	150 - 250							█	█	█	█	█								
UDH14-M	150 - 220							█	█	█										
UDH14-H	80 - 150			█	█	█														

## Sugatsune Dampers

Sugatsune offers a wide range of dampening products for a variety of applications to create a smooth soft movement and function for everyday products. These types of products are found commonly in the household and workplace. Though unnoticed in most applications, dampers are a vital part of many of today's products to bring quality, safety, and durability to both simple and sophisticated products.

Quality and durability are the key criteria for the success of products being designed today. By incorporating the Sugatsune's rotary dampers, the smooth motion created by the dampening products will provide the quality movement enhancing the feel of a product. In addition, the same smooth motion will help to protect and prolong the sensitive components and moving parts. Finally, with the soft controlled motion will help to make products safer from preventing sudden motion causing injuries.

The Sugatsune dampers are available in various shape, size and functions for many of today's products. If you cannot find an item to fit your application, our engineers are capable of designing a product to suit your requirements.

## Basic Structure

### ■ Disk Damper

Disk-type dampers are based on the resistance of a fluid (usually oil) between two disks. The friction created by the oil viscosity in combination with the disks is what provides the "braking force", or torque of the damper. The torque can be adjusted by changing the viscosity of the oil and/or the number of disks. The advantages of disk type dampers are the lack of limitation in rotation angle, that the torque is available immediately (no "dead" zone) and the slim construction.

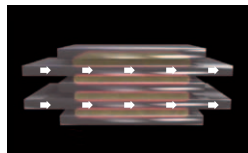

Please contact Sugatsune to assist with your custom applications.

### ■ Vane Damper

Oil viscosity is utilized to provide the "braking force" of the damper. The vane damper creates resistance by passing oil thru vanes in the housing creating pressure. The torque or "braking force" of the unit can be controlled by the size of the vane in the damper body. The vane size will control the amount of fluid passing from one chamber to the next in the damper body. The vane type is often much larger than the rotary type. Due to the size, the vane type is able to create much larger pressure which makes it able to handle larger dampening applications.

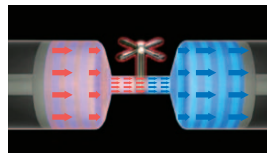

## Torque Calculation

To calculate the torque for your application, the following measurements listed below are necessary.

$$T \text{ (torque)} = L / 2 \times 9.8 \times M \text{ (N}\cdot\text{cm)}$$

$$= L / 2 \times M \text{ (Kgf}\cdot\text{cm)}$$

L= Length from pivot point to end of lid

M= Weight of the lid (kg)

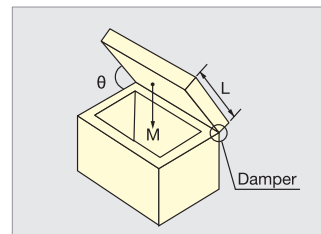

## HINGE OPTION



HG-JH14  
(See page 331 for details)



HG-JH25 / 35  
(See page 330 for details)



HG-JHW / JHWG  
(See page 329 for details)

\*ROHS Compliant versions available upon request.

# DISK DAMPER

# UDD



- Keeps lids/doors from slamming shut.
- Ideal for rounded cover applications.
- Recommended for food showcase & acrylic display.

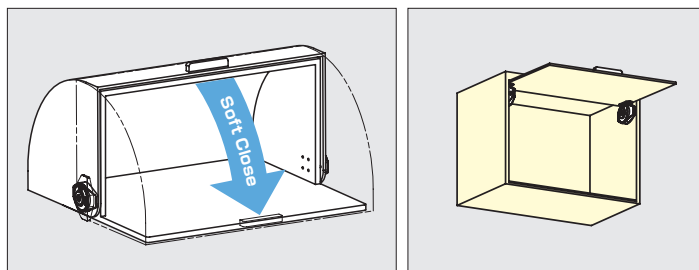

2x5.2(φ12×1.5)

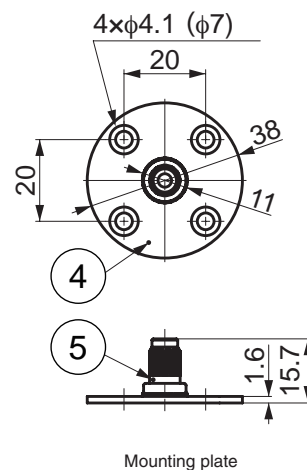
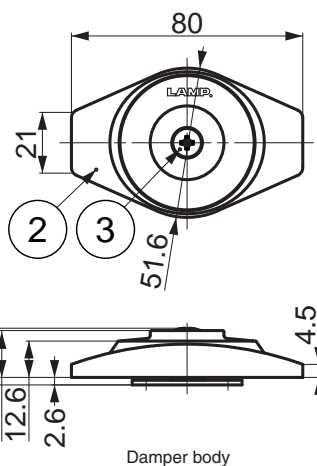
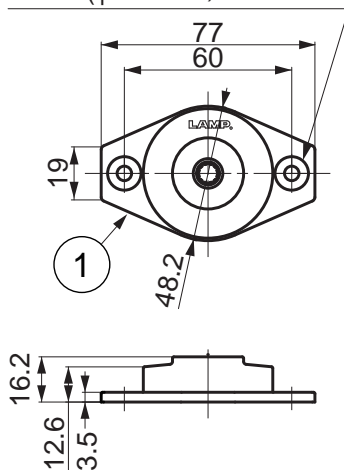

No.	Part Name	Material	Finish/Color
①	Damper body	-	-
②	Cover	ABS	Matt / Light Grey
③	Screw	Steel	Nickel
④	Mounting Plate	Steel	Nickel
⑤	Shaft	Steel	Zinc Plating

Item Code	Item Name	Spec.	Torque Moment per pc.		Weight	Box
180-022-306	UDD-S-L	Left	50~100N.cm	5.1 ~ 10.2kgf.cm	90g	20
180-022-307	UDD-S-R	Right	50~100N.cm	5.1 ~ 10.2kgf.cm	90g	20
180-022-308	UDD-M-L	Left	100~200N.cm	10.2 ~ 20.4kgf.cm	90g	20
180-022-309	UDD-M-R	Right	100~200N.cm	10.2 ~ 20.4kgf.cm	90g	20
180-022-310	UDD-H-L	Left	200~300N.cm	20.4 ~ 30.6kgf.cm	90g	20
180-022-311	UDD-H-R	Right	200~300N.cm	20.4 ~ 30.6kgf.cm	90g	20



# TORQUE DAMPER



UDH

Torque Dampers



- Keeps lids / doors from slamming shut.
- Patented technology allows small design to produce high torque and wider dampening angles.
- Stainless steel body keeps dampening torque stable and consistent.
- Ensures high durability and ideal for corrosive environments.
- Cycle tested at 70,000 for natural closing and 13,000 forced closing.

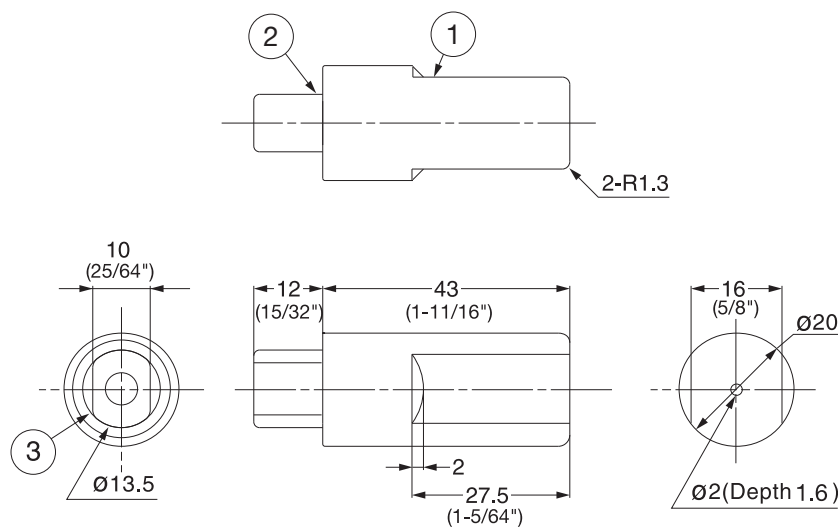
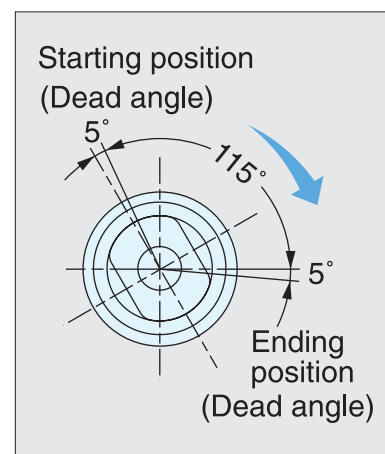
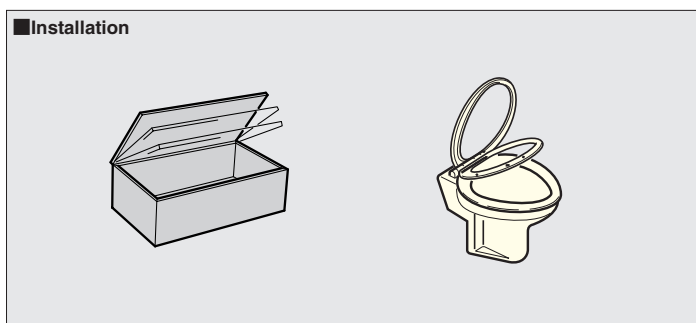

No.	Part Name	Material	Color
①	Body	Stainless Steel	Plain
②	Shaft	PBT Plastic	Left : White, Right : Grey
③	Cover Ring	PBT Plastic	-

Item Code	Item Name	Spec.	Damper Working Direction	Torque Moment per pc.		Weight	Carton
170-090-820	UDH-AMS-G	Left	Counter Clockwise	150~250N.cm	15.3~25.5kgf.cm	38g	200pcs
170-090-822	UDH-BMS-G	Right	Clockwise	150~250N.cm	15.3~25.5kgf.cm	38g	200pcs
170-090-821	UDH-AHS-G	Left	Counter Clockwise	250~350N.cm	25.5~35.7kgf.cm	38g	200pcs
170-090-823	UDH-BHS-G	Right	Clockwise	250~350N.cm	25.5~35.7kgf.cm	38g	200pcs
170-090-825	UDH-AMP-G	Left	Counter Clockwise	150~180N.cm	15.3~18.4kgf.cm	38g	200pcs
170-090-827	UDH-BMP-G	Right	Clockwise	150~180N.cm	15.3~18.4kgf.cm	38g	200pcs
170-090-826	UDH-AHP-G	Left	Counter Clockwise	180~350N.cm	18.4~35.7kgf.cm	38g	200pcs
170-090-828	UDH-BHP-G	Right	Clockwise	180~350N.cm	18.4~35.7kgf.cm	38g	200pcs

# TORQUE DAMPER



- Keeps lids / doors from slamming shut.
- Patented technology allows small design to produce high torque and wider dampening angles.
- Stainless steel body keeps dampening torque stable and consistent.
- Ensures high durability and ideal for corrosive environments.
- Cycle tested at 70,000 for natural closing and 13,000 forced closing.

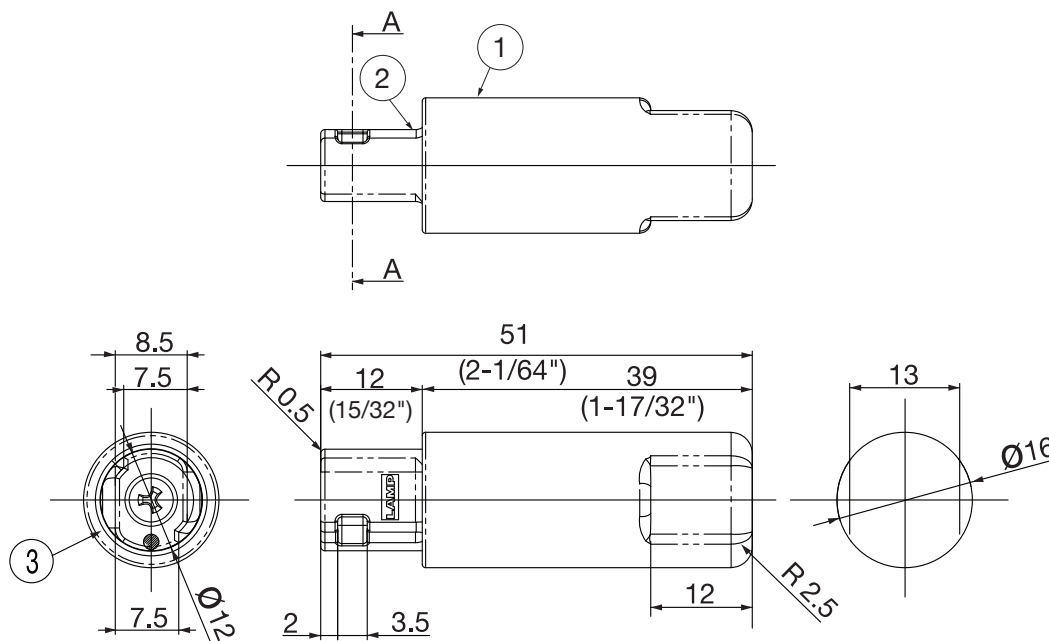
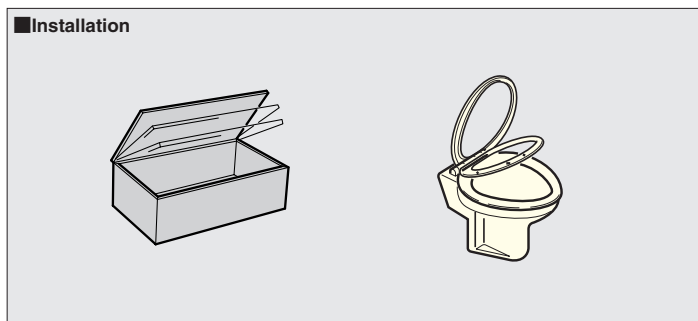
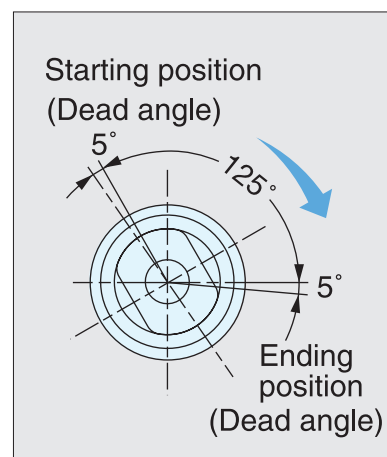

No.	Part Name	Material	Finish/Color
①	Body	Stainless Steel	Plain
②	Shaft	PBT Plastic	Left : White, Right : Grey
③	Cover Ring	PBT Plastic	-

Item Code	Item Name	Spec.	Damper Working Direction	Torque Moment per pc.		Weight	Carton
170-090-833	UDH-16N AMS	Left	Counter Clockwise	170~ 240N.cm	17.3~ 24.5kgf.cm	20g	200pcs
170-090-834	UDH-16N BMS	Right	Clockwise	170~ 240N.cm	17.3~ 24.5kgf.cm	20g	200pcs
170-090-835	UDH-16N AHS	Left	Counter Clockwise	220~ 300N.cm	22.4~ 30.6kgf.cm	20g	200pcs
170-090-836	UDH-16N BHS	Right	Clockwise	220~ 300N.cm	22.4~ 30.6kgf.cm	20g	200pcs

# TORQUE DAMPER



# UDH16



- Keeps lids / doors from slamming shut.
- Patented technology allows small design to produce high torque and wider dampening angles.
- Stainless steel body keeps dampening torque stable and consistent.
- Ensures high durability and ideal for corrosive environments.
- Cycle tested at 70,000 for natural closing and 13,000 forced closing.

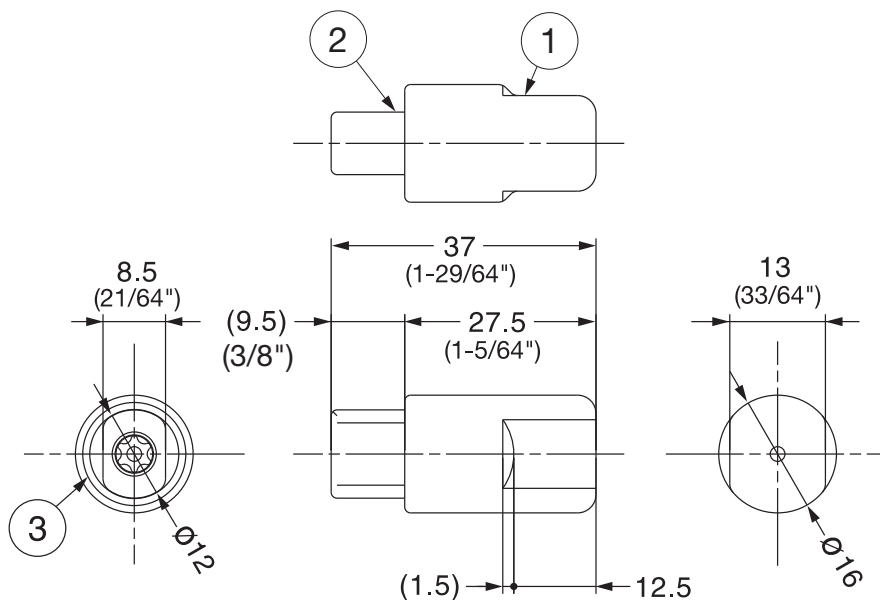
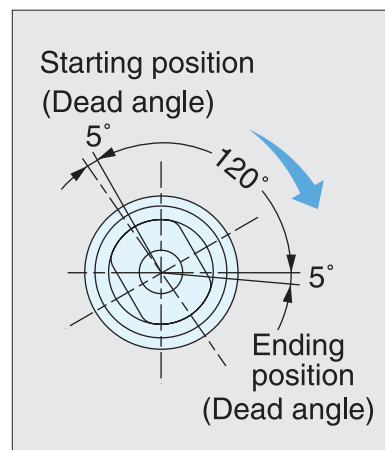
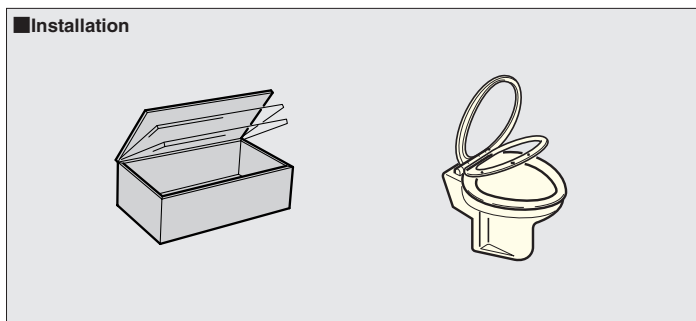

No.	Part Name	Material	Finish/Color
①	Body	Stainless Steel	Plain
②	Shaft	PBT Plastic	Left : White, Right : Grey
③	Cover Ring	PBT Plastic	—

Item Code	Item Name	Spec.	Damper Working Direction	Torque Moment per pc.		Weight	Carton
170-090-829	UDH-16AMS-G	Left	Counter Clockwise	100~170N.cm	10.2~17.3kgf.cm	16g	200pcs
170-090-831	UDH-16BMS-G	Right	Clockwise	100~170N.cm	10.2~17.3kgf.cm	16g	200pcs
170-090-830	UDH-16AHS-G	Left	Counter Clockwise	170~250N.cm	17.3~25.5kgf.cm	16g	200pcs
170-090-832	UDH-16BHS-G	Right	Clockwise	170~250N.cm	17.3~25.5kgf.cm	16g	200pcs

TORQUE DAMPER



- Keeps lids / doors from slamming shut.
- Patented technology allows small design to produce high torque and wider dampening angles.
- Stainless steel body keeps dampening torque stable and consistent.
- Ensures high durability and ideal for corrosive environments.
- Cycle tested at 70,000 for natural closing and 13,000 forced closing.

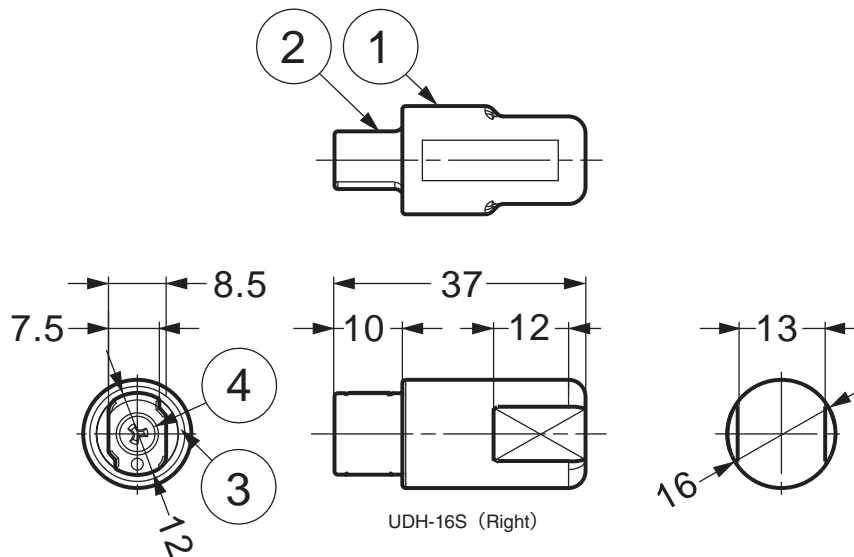
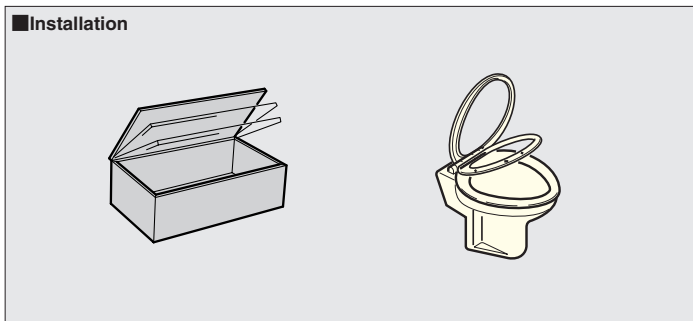
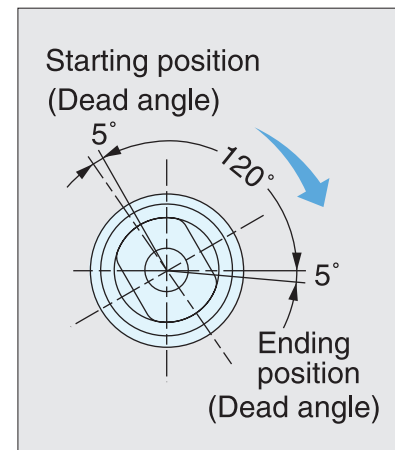

No.	Part Name	Material	Finish/Color
①	Body	Stainless Steel	Plain
②	Shaft	PBT Plastic	Left : White, Right : Grey
③	Cover Ring	PBT Plastic	-

Item Code	Item Name	Spec.	Damper Working Direction	Torque Moment per pc.		Weight	Carton
170-011-717	UDH-16SAMS	Left	Counter Clockwise	100~170N.cm	10.2~17.3kgf.cm	16g	200pcs
170-011-719	UDH-16SBMS	Right	Clockwise	100~170N.cm	10.2~17.3kgf.cm	16g	200pcs
170-011-718	UDH-16SAHS	Left	Counter Clockwise	170~250N.cm	17.3~25.5kgf.cm	16g	200pcs
170-011-720	UDH-16SBHS	Right	Clockwise	170~250N.cm	17.3~25.5kgf.cm	16g	200pcs

# TORQUE DAMPER

# UDH14



- Keeps lids / doors from slamming shut.
- Patented technology allows small design to produce high torque and wider dampening angles.
- Stainless steel body keeps dampening torque stable and consistent.
- Ensures high durability and ideal for corrosive environments.
- Cycle tested at 30,000 for natural closing and 5,000 forced closing.

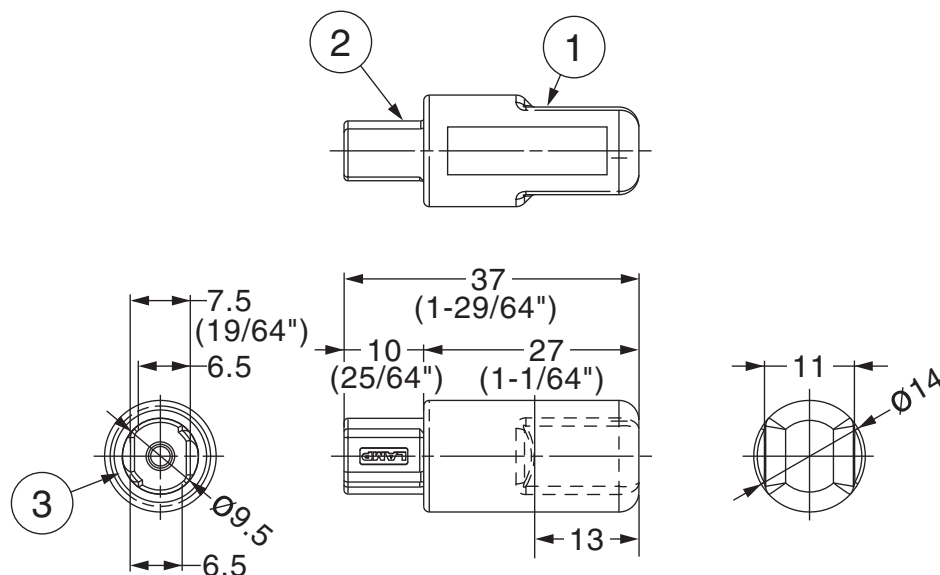
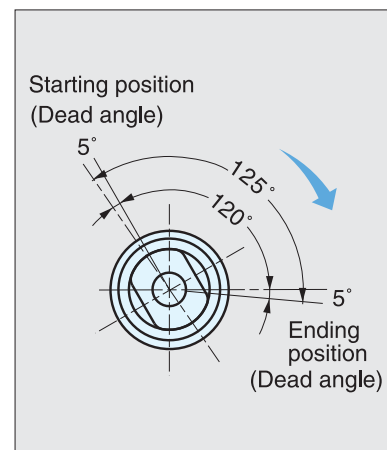
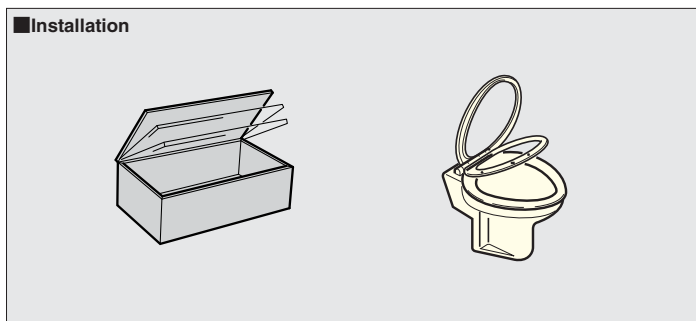

No.	Part Name	Material	Finish/Color
①	Body	Stainless Steel	Plain
②	Shaft	PBT Plastic	Left : White, Right : Grey
③	Cover Ring	PBT Plastic	—

Item Code	Item Name	Spec.	Damper Working Direction	Torque per pc.		Weight	Carton
170-028-472	UDH-14ALS	Left	Counter Clockwise	50~80N.cm	5.1~8.2kgf.cm	10g	400pcs
170-028-473	UDH-14BLS	Right	Clockwise	50~80N.cm	5.1~8.2kgf.cm	10g	400pcs
170-017-538	UDH-14AMS	Left	Counter Clockwise	80~150N.cm	8.2~15.3kgf.cm	10g	400pcs
170-017-539	UDH-14BMS	Right	Clockwise	80~150N.cm	8.2~15.3kgf.cm	10g	400pcs
170-017-540	UDH-14AHS	Left	Counter Clockwise	150~250N.cm	15.3~25.5kgf.cm	10g	400pcs
170-017-541	UDH-14BHS	Right	Clockwise	150~250N.cm	15.3~25.5kgf.cm	10g	400pcs



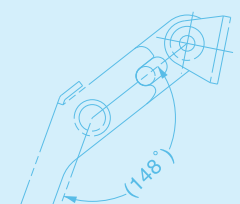

# HINGES

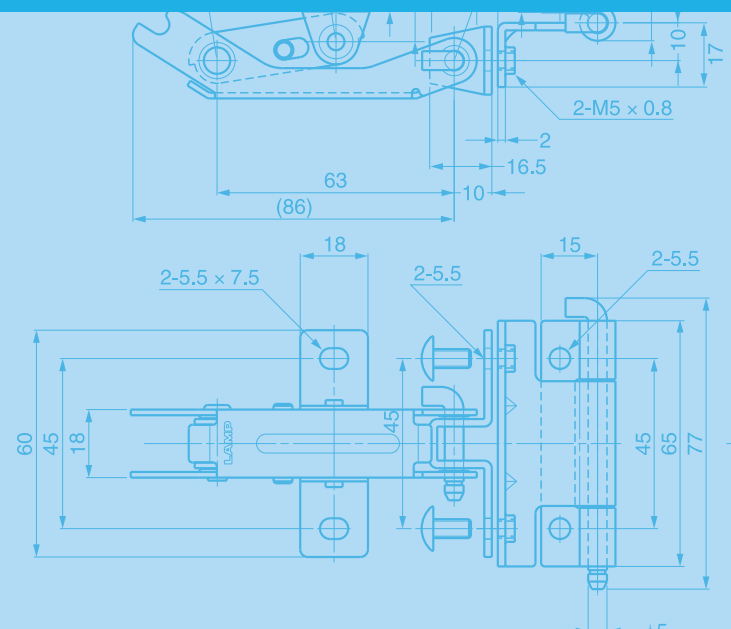

HEAVY DUTY FLAG HINGES

Picture	Item Name	Page
	HG-KH	266
	HG-KM	266

BUTT HINGES

Picture	Item Name	Page
	LSA, LSB	267
	KHA	267
	D-S-A	268
	D-S-B	268
	D-S-C	268
	LSF	269
	28300, 28400	269
	50704, 50706	269
	28000, 28500	270
	27900, 27800	270
	SYR140	271
	HG-BF1	271
	LSS	272
	28100	272
	SR75/SR75B	273
	SBR40	273
	SR40/SR50	273
	4545BSS	274
	3535SS, 4040SS	274
	FHS	274

Picture	Item Name	Page
	LSK	275
	OLY	275
	OLYA	275
	YHS	279
	HQ	279
	Discontinued DH-60RC	279
	DH60N	280
	DH60	280

PIANO HINGES

Picture	Item Name	Page
	LSN	276
	LHN	276
	LSD	277

TABLETOP HINGES

Picture	Item Name	Page
	HG-MH	277
	MH-83	278
	MA-5	278

CLEAN ROOM HINGES

Picture	Item Name	Page
	AS-HG-IS	280
	HG-CV	281
	HG-CV65N	281
	HG-CV127	282



Picture	Item Name	Page
	HG-P100	282
	AS-HG-AL	283
	AS-HG-SUS	283
	AS-HG-AL-N	284

Picture	Item Name	Page
	100-46/19, C46/49 SUS304B	314
	100-46/14, C46/14 SUS304B	314
	100-46/9, C46/9 SUS304B	315
	100-P3A, P4A/32, P4A/32-3W SUS304B	315
	R SERIES	316
	RK-50	316
	I-66	317
	I-90	317
	HES3D-190	318
	HES3D-120	319

**PIVOT HINGES**

Picture	Item Name	Page
	AS-AF-25D	284
	PL-65	307
	WP	308
	PL-60	308
	PP-60	309
	PL-100	309

**LIFT-OFF HINGES**

Picture	Item Name	Page
	LSW	288
	LSX	288
	HNH	289
	KN	289
	SNR65	290
	SNRK65	290
	NH-40	290
	BN	291
	SKH	291
	S-6166-2	292
	S-6166-6	292
	S-6173-2	293

**LATERAL SWING MECHANISM HINGES**

Picture	Item Name	Page
	LIN-X450,600	285
	LIN-X450	286
	LIN-X600	287

**CONCEALED HINGES**

Picture	Item Name	Page
	HT-160	310
	HT-160THV2	311
	H95TM	312
	H95TS	313





# HEAVY DUTY FLAG HINGE (W/BALL BEARING)



## HG-KH



- Door weight:  
KH-12-268 Max. 150kg/ pair (330lbs/ pair).  
KH-19-275 Max. 200kg/ pair (440lbs/ pair).  
KH-20-250 Max. 200kg/ pair (440lbs/ pair).

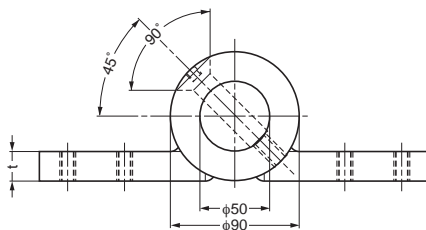
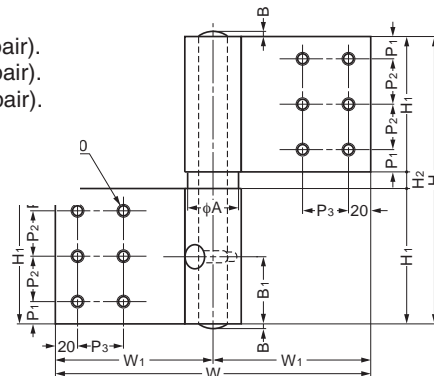

HG-KH19-275, HG-KH20-250

HG-KH12-268

### Installation

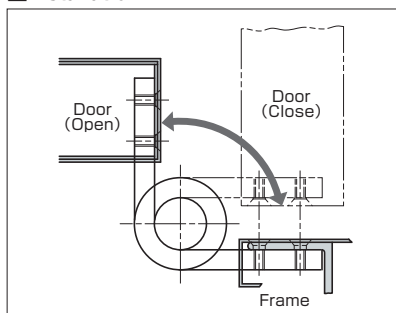

### Door Spec.

Item Name	Door Width	Door Height	Door Weight
HG-KH12-268	Max.1100	Max.2500	Max.150kg
HG-KH19-275	Max.1300	Max.3000	Max.200kg
HG-KH20-250	Max.1300	Max.3000	Max.200kg

Item Code	Item Name	Material	Finish	H	H <sub>1</sub>	H <sub>2</sub>	W	W <sub>1</sub>	A	P <sub>1</sub>	P <sub>2</sub>	P <sub>3</sub>	B	B <sub>1</sub>	t	Weight	Box
170-090-454	HG-KH12-268	Stainless Steel(SUS304)	Satin	268	125	18	300	150	49	17.5	45	45	5	62.5	-	7.4kg	1pcs
170-090-455	HG-KH19-275	Stainless Steel(SUS304)	Satin	275	125	25	300	150	80	17.5	45	45	10	62.5	19	17.2kg	1pcs
-	HG-KH20-250	Stainless Steel(SUS304)	Satin	250	114	22	280	140	78	17	40	40	10	57	20	16.6kg	1pcs

HG-KH20-250:Special Order

# HEAVY DUTY FLAG HINGE (W/BALL BEARING)



## HG-KM



- Door weight:  
KM-12-268 Max. 150kg/ pair (330lbs/ pair).  
KM-19-275 Max. 200kg/ pair (440lbs/ pair).  
KM-20-250 Max. 200kg/ pair (440lbs/ pair).

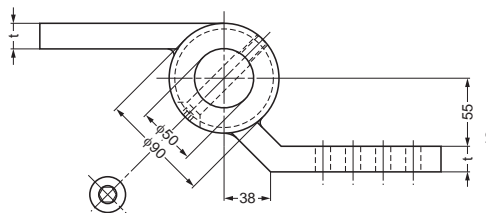
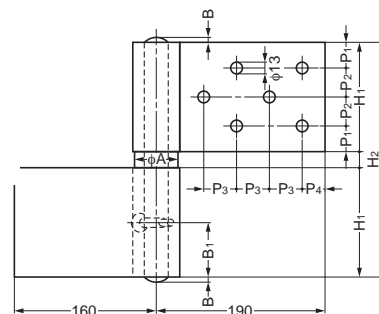

HG-KM19-275, HG-KM20-250

HG-KM12-268

### Installation

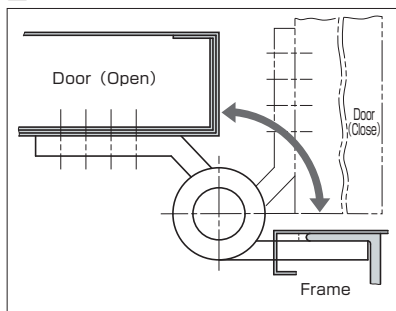

### Door Spec.

Item Name	Door Width	Door Height	Door Weight
HG-KM12-268	Max.1100	Max.2500	Max.150kg
HG-KM19-275	Max.1300	Max.3000	Max.200kg
HG-KM20-250	Max.1300	Max.3000	Max.200kg

Item Code	Item Name	Material	Finish	H	H <sub>1</sub>	H <sub>2</sub>	A	P <sub>1</sub>	P <sub>2</sub>	P <sub>3</sub>	P <sub>4</sub>	B	B <sub>1</sub>	t	Weight	Box
170-090-452	HG-KM12-268	Stainless Steel(SUS304)	Satin	268	125	18	49	27.5	35	35	25	5	62.5	-	8.3kg	1pcs
170-090-453	HG-KM19-275	Stainless Steel(SUS304)	Satin	275	125	25	80	27.5	35	30	25	10	62.5	19	19.8kg	1pcs
-	HG-KM20-250	Stainless Steel(SUS304)	Satin	250	114	22	78	28	29	25	23	10	57	20	18.1kg	1pcs

HG-KM20-250:Special Order

# BUTT HINGE



## LSA, LSB

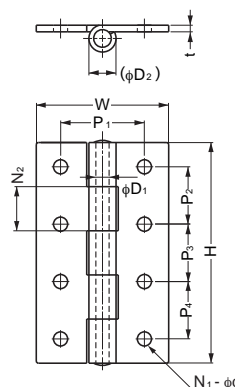

Item Code	Item Name	Holes	Material	Finish	H	W	P <sub>1</sub>	P <sub>2</sub>	P <sub>3</sub>	P <sub>4</sub>	t	d	D <sub>1</sub>	D <sub>2</sub>	N <sub>1</sub>	N <sub>2</sub>	Door Weight (pair)	Weight	Box	Carton
170-090-730	LSA-40	Without	Stainless Steel(SUS304)	Mirror	40	35	-	-	-	-	1.5	-	3	6.3	4	3	Max.6kg	25g	100pcs	400pcs
170-090-731	LSA-50	Without	Stainless Steel(SUS304)	Mirror	50	35	-	-	-	-	1.5	-	3	6.3	4	3	Max.8kg	30g	100pcs	400pcs
170-090-718	LSA-65	Without	Stainless Steel(SUS304)	Mirror	65	50	-	-	-	-	2	-	4.5	8.8	6	5	Max.13kg	66g	50pcs	200pcs
170-090-719	LSA-75	Without	Stainless Steel(SUS304)	Mirror	75	50	-	-	-	-	2	-	4.5	8.8	6	5	Max.15kg	76g	40pcs	160pcs
170-090-734	LSA-90	Without	Stainless Steel(SUS304)	Mirror	90	60	-	-	-	-	3	-	6	12.3	6	5	Max.25kg	190g	10pcs	80pcs
170-090-735	LSA-100	Without	Stainless Steel(SUS304)	Mirror	100	60	-	-	-	-	3	-	6	12.3	8	5	Max.30kg	200g	10pcs	60pcs
170-090-724	LSB-40	With	Stainless Steel(SUS304)	Mirror	40	35	22	26	-	-	1.5	3.2	3	6.3	4	3	Max.6kg	25g	100pcs	400pcs
170-090-725	LSB-50	With	Stainless Steel(SUS304)	Mirror	50	35	22	34	-	-	1.5	4.3	3	6.3	4	3	Max.8kg	30g	100pcs	400pcs
170-090-716	LSB-65	With	Stainless Steel(SUS304)	Mirror	65	50	30	23	23	-	2	4.3	4.5	8.8	6	5	Max.13kg	64g	50pcs	200pcs
170-090-717	LSB-75	With	Stainless Steel(SUS304)	Mirror	75	50	30	27	27	-	2	5.3	4.5	8.8	6	5	Max.15kg	74g	40pcs	160pcs
170-090-728	LSB-90	With	Stainless Steel(SUS304)	Mirror	90	60	38	35	35	-	3	6.4	6	12.3	6	5	Max.25kg	180g	10pcs	80pcs
170-090-729	LSB-100	With	Stainless Steel(SUS304)	Mirror	100	60	38	26	26	26	3	6.4	6	12.3	8	5	Max.30kg	195g	10pcs	60pcs

# BUTT HINGE



## KHA

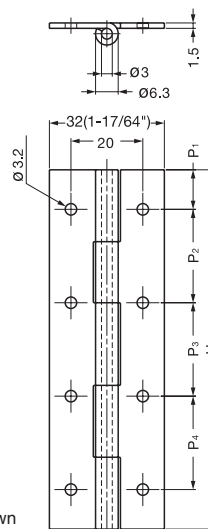

KHA-100C shown

Item Code	Item Name	Material	Finish	H	P <sub>1</sub>	P <sub>2</sub>	P <sub>3</sub>	P <sub>4</sub>	Knuckles	Weight
170-091-180	KHA-25C	Stainless Steel(SUS304)	Mirror	25	6	13	-	-	3	13g
170-091-181	KHA-30C	Stainless Steel(SUS304)	Mirror	30	7	16	-	-	3	16g
170-091-198	KHA-40C	Stainless Steel(SUS304)	Mirror	40	8	24	-	-	3	21g
170-091-199	KHA-50C	Stainless Steel(SUS304)	Mirror	50	10	30	-	-	3	26g
170-091-200	KHA-60C	Stainless Steel(SUS304)	Mirror	60	8	22	22	-	5	31g
170-091-201	KHA-65C	Stainless Steel(SUS304)	Mirror	65	8.5	24	24	-	5	34g
170-091-202	KHA-75C	Stainless Steel(SUS304)	Mirror	75	9.5	28	28	-	5	39g
170-091-203	KHA-80C	Stainless Steel(SUS304)	Mirror	80	10	30	30	-	5	42g
170-091-204	KHA-90C	Stainless Steel(SUS304)	Mirror	90	10	35	35	-	5	47g
170-091-205	KHA-100C	Stainless Steel(SUS304)	Mirror	100	11	26	26	26	5	52g

# BUTT HINGE



## D-S-A

- Stainless steel hinge with polyacetal bushing.

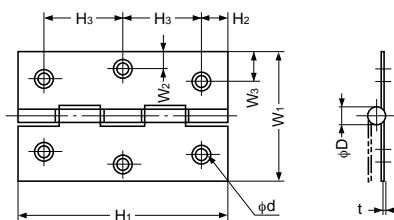

Item Code	Item Name	Material	H <sub>1</sub>	H <sub>2</sub>	H <sub>3</sub>	W <sub>1</sub>	W <sub>2</sub>	W <sub>3</sub>	D	t	d	Knuckles	Holes	Weight
170-090-265	D-S-51A	Stainless Steel(SUS304)	51	7.5	36	39	-	7	6.2	1.3	4.2	3	4	27.4g
170-090-266	D-S-64A	Stainless Steel(SUS304)	64	7	25	42.5	6	8	6.2	1.3	5	5	6	36.5g
170-090-267	D-S-76A	Stainless Steel(SUS304)	76	9	29	50	7	9	7.4	1.5	5.2	5	6	59.5g
170-090-268	D-S-89A	Stainless Steel(SUS304)	89	10.5	34	56.5	7.5	10.5	9	1.8	5.4	5	6	91.6g
170-090-269	D-S-102A	Stainless Steel(SUS304)	102	9	28	70	9	14	9.5	1.8	6	5	8	132.5g
170-090-270	D-S-127A	Stainless Steel(SUS304)	127	11	35	82	10.5	16	11.5	1.8	6	5	8	231.5g

# BUTT HINGE



## D-S-B

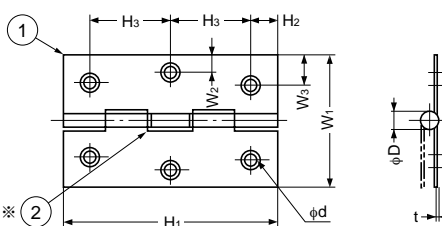

※D-S-51B, 64B:Without ring  
D-S-76B~127B:With ring

No.	Part Name	Material	Finish
①	Body	Stainless Steel(SUS430)	Polished
②	Ring	Polyamide	-

Item Code	Item Name	H <sub>1</sub>	H <sub>2</sub>	H <sub>3</sub>	W <sub>1</sub>	W <sub>2</sub>	W <sub>3</sub>	φ D	t	φ d	Knuckles	Holes	Weight
170-090-271	D-S-51B	51	7.5	36	34.5	-	6.5	4.8	0.8	4.4	5	4	15.2g
170-090-272	D-S-64B	64	8	24	40	5.5	9	5	0.8	4.2	5	6	23.8g
170-090-273	D-S-76B	76	10	28	46	7.5	10	6	1	4.5	5	6	37.8g
170-090-274	D-S-89B	89	9.5	35	56	8	12	7	1.2	5.5	5	6	63.6g
170-090-275	D-S-102B	102	10.5	27	66.5	9	12	8	1.5	5.5	5	8	96.4g
170-090-276	D-S-127B	127	11	35	82	10	17	9	1.5	5.4	5	8	161.5g

# BUTT HINGE



## D-S-C

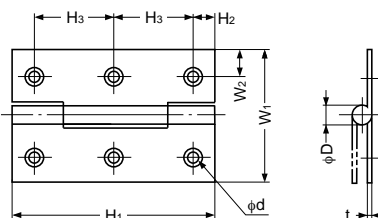

Item Code	Item Name	Material	Finish	H <sub>1</sub>	H <sub>2</sub>	H <sub>3</sub>	W <sub>1</sub>	W <sub>2</sub>	φ D	t	φ d	Knuckles	Holes	Weight
170-090-277	D-S-25C	Stainless Steel(SUS430)	Polished	25.5	5	15.5	21	3.5	3.7	0.75	3.5	3	4	4.4g
170-090-278	D-S-32C	Stainless Steel(SUS430)	Polished	31.5	5	21.5	22.5	4	3.7	0.75	3.5	3	4	5.7g
170-090-279	D-S-38C	Stainless Steel(SUS430)	Polished	38	5.5	27	26	5	3.8	0.75	3.8	3	4	7.7g
170-090-280	D-S-51C	Stainless Steel(SUS430)	Polished	51	7	18.5	30.5	6	4.2	0.8	4	5	6	12.9g
170-090-281	D-S-64C	Stainless Steel(SUS430)	Polished	64	9	23	33	6.2	4.4	0.8	4	5	6	19.4g

# BUTT HINGE



# LSF

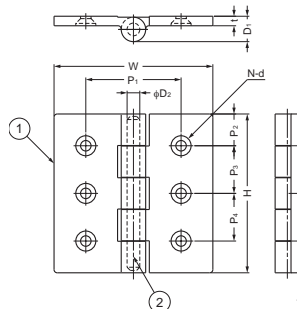

- 316 Stainless Steel construction ideal for exposed application.

No.	Part Name	Material	Finish
①	Body	Stainless Steel(SCS14)	Mirror
②	Shaft	Stainless Steel(SUS316)	-

\*SCS14 is similar to SUS316

Item Code	Item Name	H	W	P <sub>1</sub>	P <sub>2</sub>	P <sub>3</sub>	P <sub>4</sub>	t	D <sub>1</sub>	D <sub>2</sub>	Knuckles	N	d	Door Weight (per 2pcs)	Weight	Box	Carton
170-090-720	LSF-50	50	50	35	15	20	-	5	14	6	3	4	M4	Max.35kg	110g	20pcs	100pcs
170-090-721	LSF-65	65	65	40	15	35	-	5	14	6	3	4	M5	Max.45kg	190g	20pcs	80pcs
170-090-722	LSF-75	75	75	50	17.5	40	-	6	16	8	3	4	M6	Max.65kg	305g	10pcs	50pcs
170-090-723	LSF-100	100	100	60	20	30	30	6	16	8	5	6	M6	Max.85kg	500g	10pcs	30pcs

# BUTT HINGE



# 28300, 28400

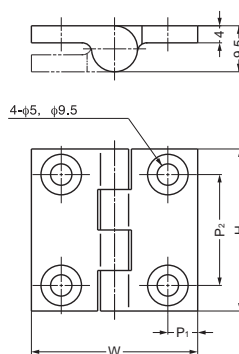

- 316 Stainless Steel construction ideal for exposed application.
- Door weight: Max. 4kg/pair.

Item Code	Item Name	Material	Finish	H	W	P <sub>1</sub>	P <sub>2</sub>	Door Width	Door Height	Door Thickness	Door Weight	Weight	Box	Carton
170-096-004	28300	Stainless Steel(SCS14)	Mirror	38	39	7	26	Max.450	Max.700	Max.21	Max.4kg	55g	20pcs	100pcs
170-096-005	28400	Stainless Steel(SCS14)	Mirror	50	50	7.5	34	Max.450	Max.700	Max.21	Max.4kg	90g	20pcs	100pcs

\*SCS14 is similar to SUS316

# LEAF HINGE



# 50704, 50706

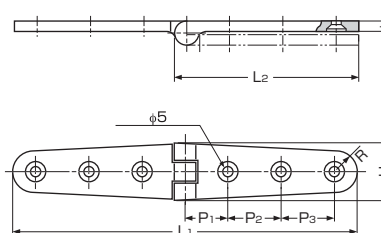

- 316 Stainless Steel construction ideal for exposed application.
- Door weight: Max. 2.6kg/pair.

Item Code	Item Name	Holes	Material	Finish	L <sub>1</sub>	L <sub>2</sub>	H	R	P <sub>1</sub>	P <sub>2</sub>	P <sub>3</sub>	t	Weight	Box	Carton
170-096-000	50704	4pcs	Stainless Steel(SCS14)	Mirror	105	57	26.5	9	17.5	25	-	4	75g	20pcs	100pcs
170-096-001	50706	6pcs	Stainless Steel(SCS14)	Mirror	158	84	26.5	9	19.5	25	25	4	115g	20pcs	100pcs

\*SCS14 is similar to SUS316

# BUTT HINGE



28000, 28500

- 316 Stainless Steel construction ideal for exposed application.
- Door weight: Max. 4kg/pair.

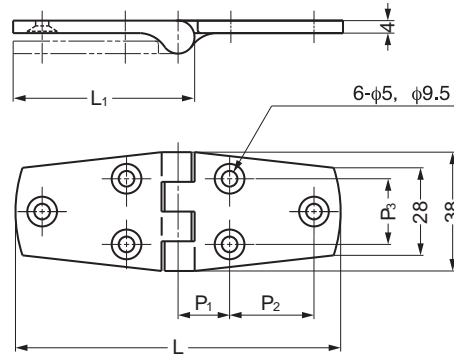
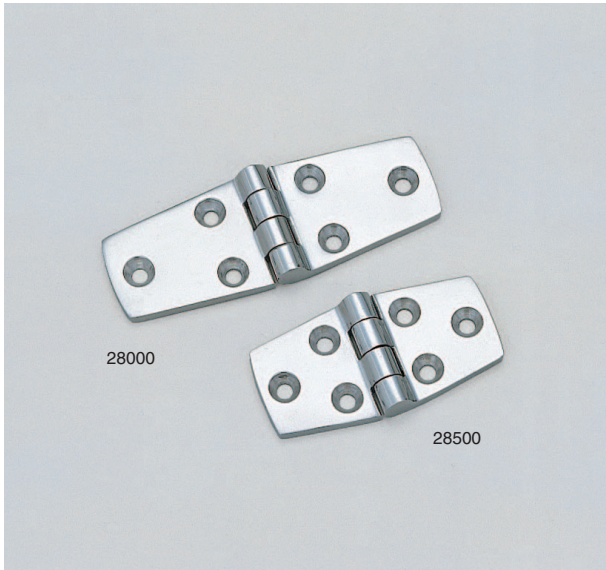

Item Code	Item Name	Material	Finish	L	L <sub>1</sub>	P <sub>1</sub>	P <sub>2</sub>	P <sub>3</sub>	Door Width	Door Height	Door Thickness	Door Weight	Weight	Box	Carton
170-096-002	28500	Stainless Steel(SCS14)	Mirror	74	42	13	17	20	Max.450	Max.700	Max.21	Max.4kg	85 g	20pcs	100pcs
170-096-003	28000	Stainless Steel(SCS14)	Mirror	104	57	16.5	27	21	Max.450	Max.700	Max.21	Max.4kg	115 g	20pcs	100pcs

\*SCS14 is similar to SUS316

# BUTT HINGE



27900, 27800

- 316 Stainless Steel construction ideal for exposed application.
- Door weight: Max. 4kg/pair.

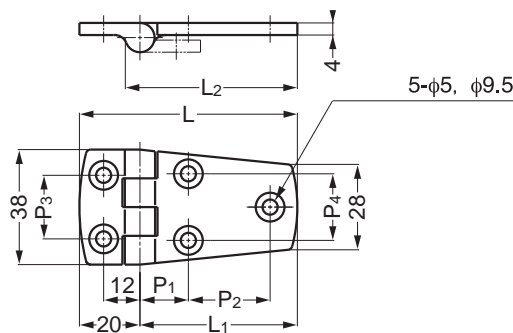
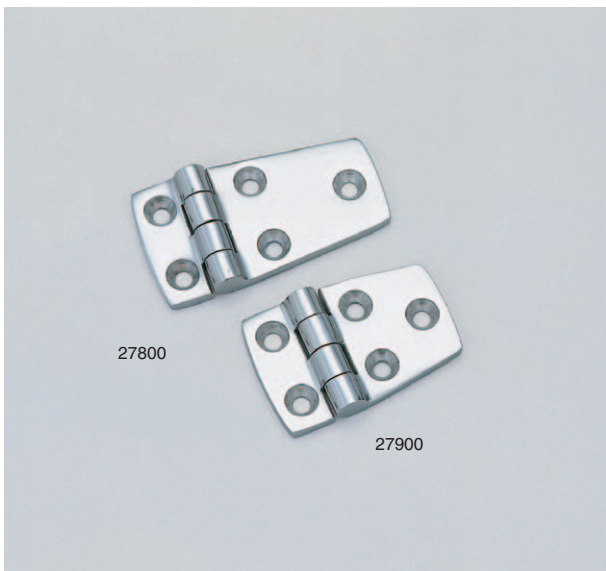

Item Code	Item Name	Material	Finish	L	L <sub>1</sub>	L <sub>2</sub>	P <sub>1</sub>	P <sub>2</sub>	P <sub>3</sub>	P <sub>4</sub>	Door Width	Door Height	Door Thickness	Door Weight	Weight	Box	Carton
170-096-008	27900	Stainless Steel(SCS14)	Mirror	58	38	42	13.5	16.5	21	20	Max.450	Max.700	Max.21	Max.4kg	70g	20pcs	100pcs
170-096-007	27800	Stainless Steel(SCS14)	Mirror	72	52	57	16	27	22	21	Max.450	Max.700	Max.21	Max.4kg	85g	20pcs	100pcs

\*SCS14 is similar to SUS316



# BUTT HINGE



## SYR140

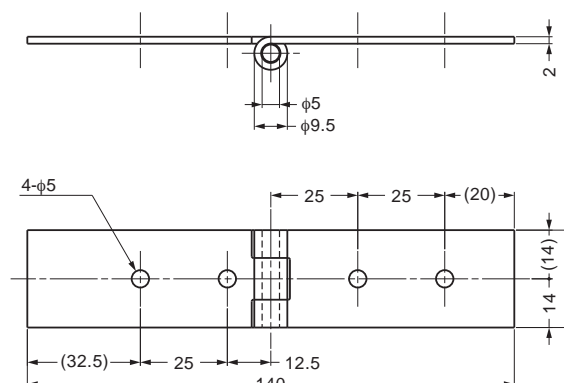

Item Code	Item Name	Material	Finish	Box
170-099-045	SYR140	Stainless Steel(SUS304)	Plain	125pcs

# BUTT HINGE



## HG-BF1



- Rim on edges prevents pin removal.

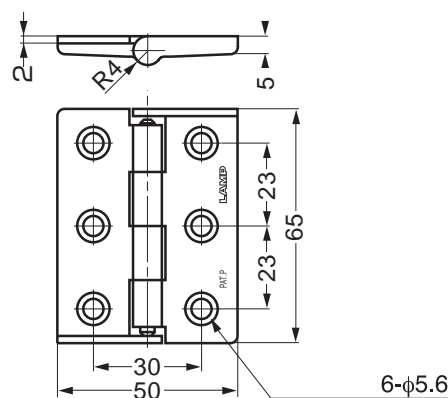

Item Code	Item Name	Material	Finish	Weight	Box	Carton
170-091-560	HG-BF1	Stainless Steel(SUS304)	Polished	63g	20pcs	120pcs

# BUTT HINGE



LSS



LSS-H-N65

LSS-Z-A65

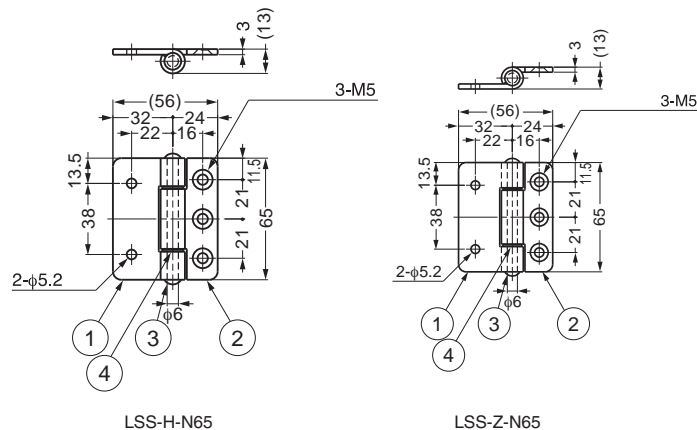

No.	Part Name	Material	Finish
①	BodyA	Stainless Steel(SUS304)	Satin
②	BodyB	Stainless Steel(SUS304)	Satin
③	Shaft	Stainless Steel(SUS304)	-
④	Washer	Stainless Steel(SUS304)	-

Item Code	Item Name	Holes	Weight	Box
170-090-542	LSS-H-A65	without	125g	80pcs
170-090-541	LSS-H-N65	with	125g	80pcs
170-090-544	LSS-Z-A65	without	125g	80pcs
170-090-543	LSS-Z-N65	with	125g	80pcs

# BUTT HINGE



28100



- 316 Stainless Steel construction ideal for exposed application.
- Door weight: Max. 4kg/pair.

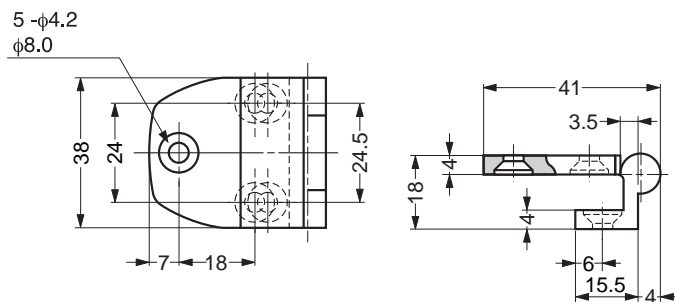

Item Code	Item Name	Material	Finish	Door Width	Door Height	Door Thickness	Door Weight	Weight	Box	Carton
170-096-006	28100	Stainless Steel(SCS14)	Mirror	Max.450	Max.700	Max.21	Max.4kg	78.5g	20pcs	1,400/1pcs

\*SCS14 is similar to SUS316

**BUTT HINGE**



**SR75/SR75B**



SR75

SR75B

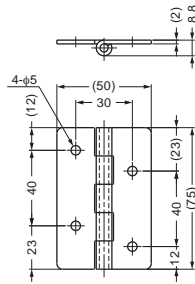

SR75

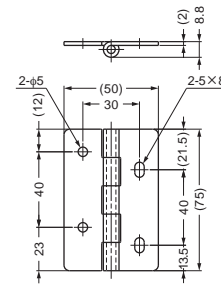

SR75B

Item Code	Item Name	Material	Finish	Box
170-099-086	SR75	Stainless Steel(SUS304)	Plain	100pcs
170-099-047	SR75B	Stainless Steel(SUS304)	Plain	100pcs

**BUTT HINGE**



**SBR40**

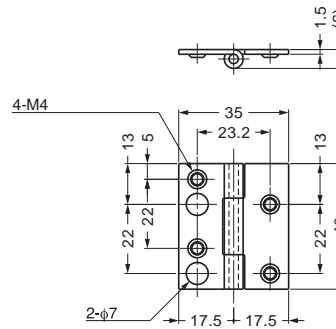

Item Code	Item Name	Material	Finish	Weight	Box
170-099-088	SBR40	Stainless Steel(SUS304)	Plain	21g	100pcs

**BUTT HINGE**



**SR40/SR50**

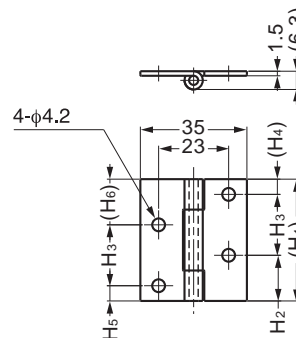

Item Code	Item Name	Material	Finish	(H <sub>1</sub> )	H <sub>2</sub>	H <sub>3</sub>	(H <sub>4</sub> )	H <sub>5</sub>	(H <sub>6</sub> )	Box
170-099-044	SR40	Stainless Steel(SUS304)	Plain	40	15	20	5	5	15	250pcs
170-099-042	SR50	Stainless Steel(SUS304)	Plain	50	18.5	26	5.5	5.5	18.5	250pcs



# BUTT HINGE (W/BALL BEARING)



**4545BSS**

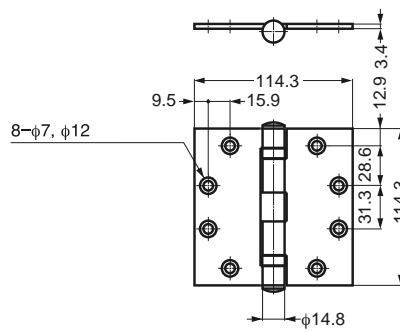

- Ball bearing provides smooth movement.
- Door weight: Max. 45kg/pair.

Item Code	Item Name	Material	Finish	Door Weight	Weight	Box	Carton
170-920-184	4545BSS	Stainless Steel(SUS304)	Satin	Max.45kg	420g	2pcs	50pcs

# BUTT HINGE



**3535SS, 4040SS**

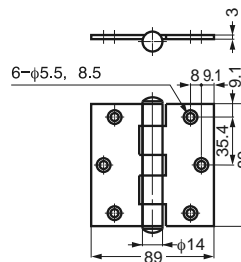
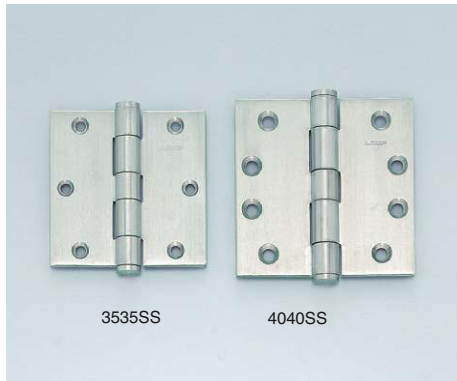

3535SS

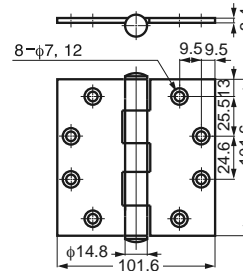

4040SS

- Door weight:  
3535/SS Max. 25kg/pair.  
4040/SS Max. 40kg/pair.
- A special plastic washer is also available. For more information contact a sales representative.

Item Code	Item Name	Material	Finish	Door Weight	Weight	Box	Carton
170-920-181	3535SS	Stainless Steel(SUS304)	Satin	Max.25kg	145g	2pcs	100pcs
170-920-182	4040SS	Stainless Steel(SUS304)	Satin	Max.40kg	195g	2pcs	50pcs

# BUTT HINGE



**FHS**

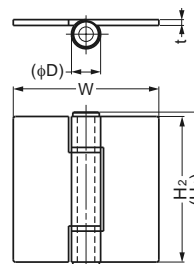

FHS-100

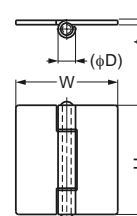

FHS-75

Item Code	Item Name	Material	Finish	(H <sub>1</sub> )	H <sub>2</sub>	W	(φ D)	t	Knuckles	Weight	Box
170-090-479	FHS-50	Stainless Steel(SUS304)	Satin	-	50	50	12	3	3	20g	12pcs
170-090-478	FHS-60	Stainless Steel(SUS304)	Satin	-	60	64	12	3	3	25g	12pcs
170-090-477	FHS-75	Stainless Steel(SUS304)	Satin	-	75	70	12	3	3	30g	12pcs
170-090-476	FHS-100	Stainless Steel(SUS304)	Satin	110	100	100	20	4	3	60g	40pcs
170-090-475	FHS-125	Stainless Steel(SUS304)	Satin	135	125	100	20	4	5	70g	30pcs
170-090-474	FHS-150	Stainless Steel(SUS304)	Satin	160	150	120	20	4	5	90g	25pcs

# STAINLESS STEEL WELD-ON BUTT HINGE



LSK

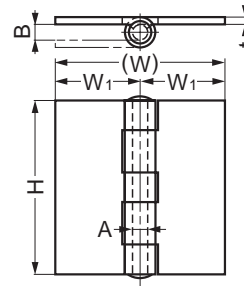

Item Code	Item Name	Material	Finish	H	W <sub>1</sub>	W	A	B	t	Weight	Box	Carton
170-090-445	LSK-1157-1	Stainless Steel(SUS304)	Satin	51	25	50	6	6	2.5	76g	10pcs	250pcs
170-090-446	LSK-1157-2	Stainless Steel(SUS304)	Satin	64	32	64	7	7	3	141g	10pcs	150pcs
170-090-447	LSK-1157-3	Stainless Steel(SUS304)	Satin	76	37	74	7	7	3	188g	10pcs	100pcs
170-090-448	LSK-1157-4	Stainless Steel(SUS304)	Satin	89	43.5	87	8	8	3	257g	10pcs	80pcs
170-090-449	LSK-1157-5	Stainless Steel(SUS304)	Satin	101.6	49.5	99	8	8	4	417g	10pcs	50pcs
170-090-450	LSK-1157-6	Stainless Steel(SUS304)	Satin	127	59.5	119	11	11	4	681g	6pcs	30pcs
170-090-451	LSK-1157-7	Stainless Steel(SUS304)	Satin	152	71.5	143	12	12	4	928g	4pcs	20pcs

# BUTT HINGE



OLY



• Pin can be remove.

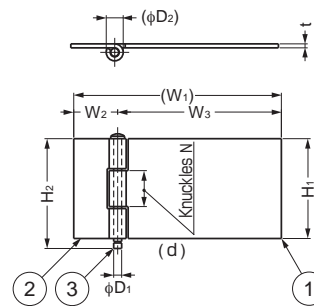

Item Code	Item Name	Material	Finish	H <sub>1</sub>	H <sub>2</sub>	(W <sub>1</sub> )	W <sub>2</sub>	W <sub>3</sub>	t	φ D <sub>1</sub>	(φ D <sub>2</sub> )	N	d	Weight	Box
170-099-794	OLY-90S	Stainless Steel(SUS304)	Plain	30	35	90	18	72	2	4	8.5	3	3	55g	100pcs
170-099-793	OLY-98S	Stainless Steel(SUS304)	Plain	38	43	98	18	80	2	4	8.5	3	3	75g	100pcs
170-099-423	OLY-104S	Stainless Steel(SUS304)	Plain	50	55	104	22	82	2	4	8.5	3	3	100g	80pcs

# BUTT HINGE



OLYA



• Pin can be remove.

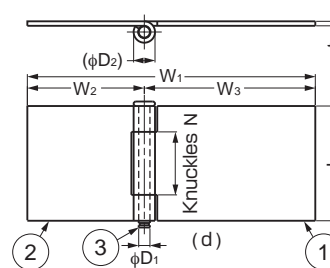

No.	Part Name	Material	Finish
①	BodyA	Stainless Steel(SUS304)	Polished
②	BodyB	Stainless Steel(SUS304)	Polished
③	Shaft	Stainless Steel(SUS304)	Plain

Item Code	Item Name	L	W <sub>1</sub>	W <sub>2</sub>	W <sub>3</sub>	t	d	D <sub>1</sub>	(D <sub>2</sub> )	N	Weight
170-099-772	OLYA-128S	51	128	52	76	2	4	5	9.5	3	120g
170-099-771	OLYA-185S	65	185	30	155	3	5	6	12.5	5	330g

# PIANO HINGE (WELD-ON)



LSN

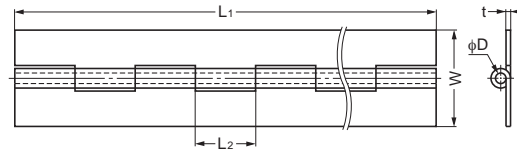
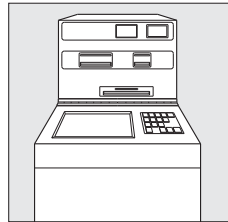

Material	Finish
Stainless Steel(SUS304)	Polished(LSN-8, 15, 20) Plain(LSN30, 40)

Item Code	Item Name	L <sub>1</sub>	L <sub>2</sub>	W	t	D
170-099-376	LSN8-2300	300	12.5	25	0.8	2.6
170-099-377	LSN8-25-600	600	12.5	25	0.8	2.6
170-099-362	LSN8-25-1000	1000	12.5	25	0.8	2.6
170-099-187	LSN8-25-1800	1800	12.5	25	0.8	2.6
170-099-378	LSN8-32-300	300	12.5	32	0.8	2.6
170-099-372	LSN8-32-600	600	12.5	32	0.8	2.6
170-099-361	LSN8-32-1000	1000	12.5	32	0.8	2.6
170-099-186	LSN8-32-1800	1800	12.5	32	0.8	2.6
170-099-198	LSN8-38-1000	1000	12.5	38	0.8	2.6
170-099-184	LSN8-38-1800	1800	12.5	38	0.8	2.6
170-149-329	LSN15-32-300	300	20	32	1.5	3.5
170-099-373	LSN15-32-350	350	20	32	1.5	3.5
170-149-330	LSN15-32-450	450	20	32	1.5	3.5
170-149-331	LSN15-32-600	600	20	32	1.5	3.5

Item Code	Item Name	L <sub>1</sub>	L <sub>2</sub>	W	t	D
170-099-982	LSN15-32-750	750	20	32	1.5	3.5
170-099-374	LSN15-32-850	850	20	32	1.5	3.5
170-099-375	LSN15-32-900	900	20	32	1.5	3.5
170-099-808	LSN15-32-1000	1000	20	32	1.5	3.5
170-099-030	LSN15-38-1000	1000	20	38	1.5	3.5
170-099-031	LSN15-38-1800	1800	20	38	1.5	3.5
170-090-709	LSN15-50-1000	1000	20	50	1.5	3.5
170-099-182	LSN15-50-1800	1800	20	50	1.5	3.5
170-099-029	LSN20-50-1000	1000	50	50	2	5
170-012-596	LSN30-100-1000	1000	50	100	3.0	8.0
170-012-597	LSN30-100-2000	2000	50	100	3.0	8.0
170-012-598	LSN40-100-500*	500	90	100	4.0	10.0
170-012-599	LSN40-100-1000*	1000	90	100	4.0	10.0

\*The knuckles on both ends are welded to prevent the pin from being removed.

# PIANO HINGE



LHN

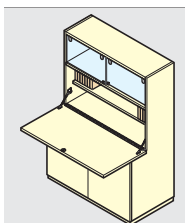
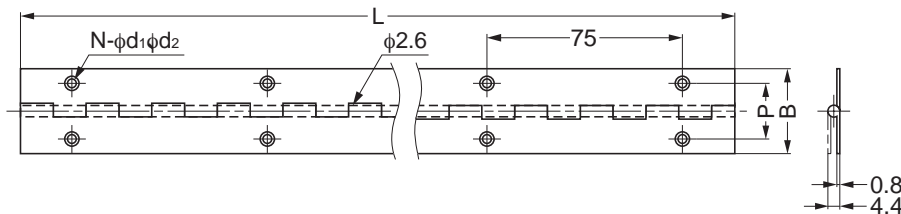
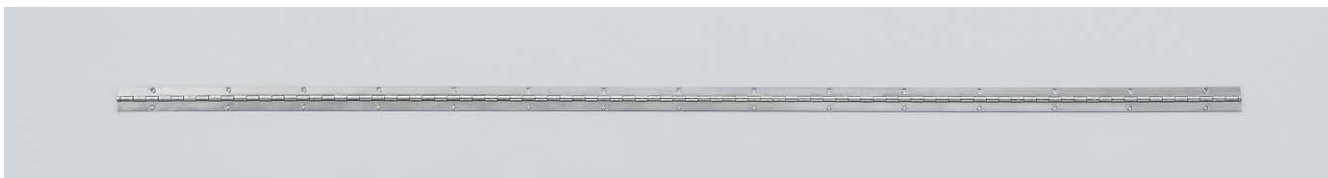

Item Code	Item Name	Material	Finish	L	B	P	Holes	d <sub>1</sub>	d <sub>2</sub>	Weight	Carton
170-097-846	LHN-32-1200	Stainless Steel(SUS304)	Mirror	1200	32	20	32	4	5.2	340g	30pcs
170-097-847	LHN-32-1500	Stainless Steel(SUS304)	Mirror	1500	32	20	40	4	5.2	425g	30pcs
170-097-848	LHN-32-1872	Stainless Steel(SUS304)	Mirror	1872	32	20	50	4	5.2	530g	30pcs
170-097-849	LHN-32-2100	Stainless Steel(SUS304)	Mirror	2100	32	20	56	4	5.2	595g	30pcs
170-097-850	LHN-38-1200	Stainless Steel(SUS304)	Mirror	1200	38	22.5	32	4.6	6	384g	30pcs
170-097-843	LHN-38-1500	Stainless Steel(SUS304)	Mirror	1500	38	22.5	40	4.6	6	480g	30pcs
170-097-844	LHN-38-1872	Stainless Steel(SUS304)	Mirror	1872	38	22.5	50	4.6	6	600g	30pcs
170-097-845	LHN-38-2100	Stainless Steel(SUS304)	Mirror	2100	38	22.5	56	4.6	6	670g	30pcs

# PIANO HINGE



## LSD

- Double folded construction provides extra rigidity.
- The knuckles on both ends are crimped to prevent the pin from being removed. The hinge pin does not occupy the crimped knuckles on both ends.

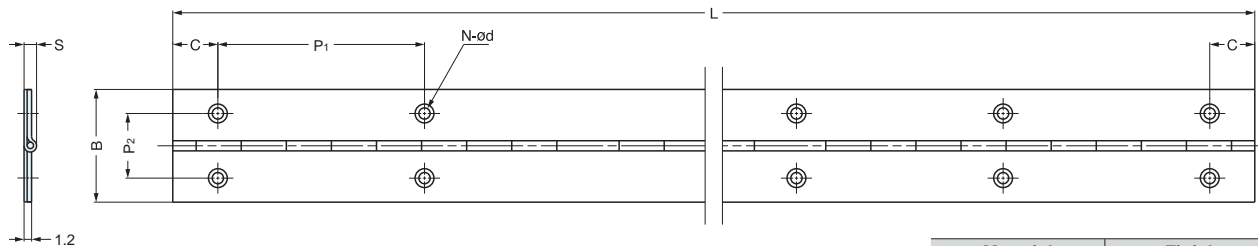

Material	Finish
304 Stainless Steel	Satin

Item Code	Item Name	L	B	C	P <sub>1</sub>	P <sub>2</sub>	N	d	S	Weight	Box	Carton
170-090-246	LSD-240	240	30	10.5	43.5	17	12	3	3.5	65g	20pcs	200pcs
170-090-247	LSD-300	300	30	10.5	46.3	17	14	3	3.5	80g	20pcs	200pcs
170-090-248	LSD-360	360	30	15	47	17	16	3	3.5	95g	20pcs	200pcs
170-090-249	LSD-450	450	30	14.5	60	17	16	3	3.5	120g	20pcs	200pcs
170-090-250	LSD-600	600	30	14	63.3	17	20	3	3.5	190g	20pcs	200pcs
170-090-251	LSD-900	900	30	14	62.3	17	30	3	3.5	280g	20pcs	100pcs

# TABLETOP PIANO HINGE



## HG-MH

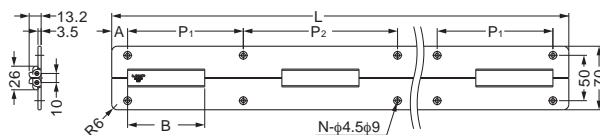

### ■ Bore Dimensions

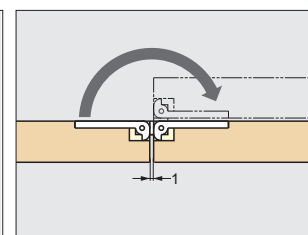
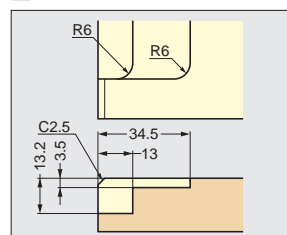

- Unique "Double Joint" mechanism allows 180° opening.
- ※HG-MH is not a load bearing hinge. A secondary support is recommended.

Item Code	Item Name	Material	Finish	L	A	P <sub>1</sub>	P <sub>2</sub>	B	N
170-012-587	HG-MH400S	Aluminum Alloy	Anodized /Matte Silver	400	15	111	148	74	8
170-012-588	HG-MH400BR	Aluminum Alloy	Anodized /Brown	400	15	111	148	74	8
170-012-589	HG-MH400BL	Aluminum Alloy	Anodized /Black	400	15	111	148	74	8
170-012-590	HG-MH800S	Aluminum Alloy	Anodized /Matte Silver	800	17.5	127.5	170	85	12
170-012-591	HG-MH800BR	Aluminum Alloy	Anodized /Brown	800	17.5	127.5	170	85	12
170-012-592	HG-MH800BL	Aluminum Alloy	Anodized /Black	800	17.5	127.5	170	85	12
170-012-593	HG-MH1100S	Aluminum Alloy	Anodized /Matte Silver	1100	16.5	145.5	194	97	14
170-012-594	HG-MH1100BR	Aluminum Alloy	Anodized /Brown	1100	16.5	145.5	194	97	14
170-012-595	HG-MH1100BL	Aluminum Alloy	Anodized /Black	1100	16.5	145.5	194	97	14

# TABLETOP HINGE



## MH-83



- Door Size: Max. W450 x H700 x t21mm.
- Door Weight: Max. 4kg/pair.
- Double pivot hinge with 180° opening.

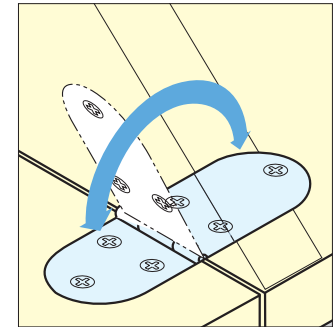
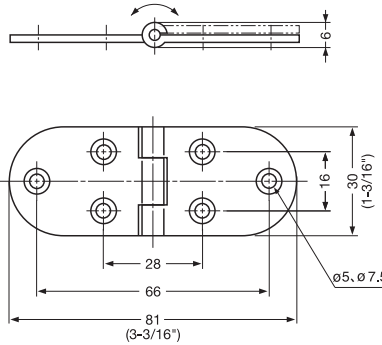

Installation

Item Code	Item Name	Thickness	Weight	Box	Carton	Material	Finish
170-090-045	MH-83S	1.5	28g	100pcs	1000pcs	304 Stainless Steel	Satin (S)
170-090-046	MH-83CR	1.6	31g	100pcs	1000pcs	Steel	Chrome (CR)

# TABLETOP HINGE



## MA-5



- Door Size: Max. W450 x H700 x t21mm.
- Door Weight: Max. 4kg/pair.
- Double pivot hinge with 180° opening.

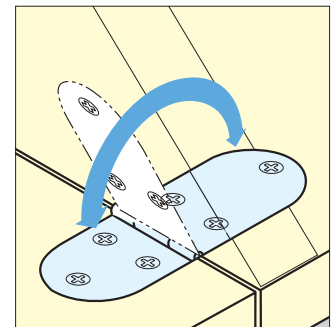
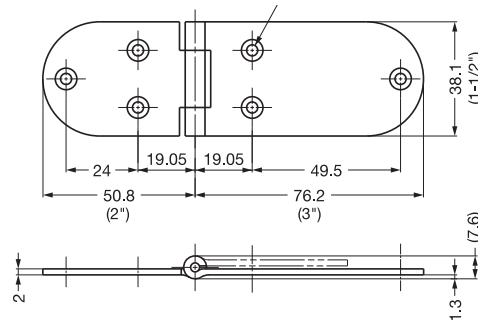

Installation

Material	Finish
304 Stainless Steel	Mirror

Item Code	Item Name	Weight	Box	Carton
170-918-023	MA-5	74g	35pcs	350pcs



**BUTT HINGE**



**YHS**

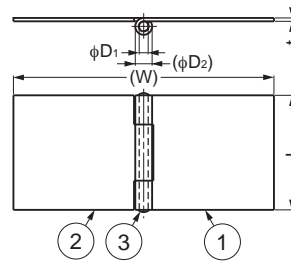

No.	Part Name	Material	Finish
①	BodyA	Stainless Steel(SUS304)	Polished
②	BodyB	Stainless Steel(SUS304)	Polished
③	Shaft	Stainless Steel(SUS304)	Plain

Item Code	Item Name	L	(W)	t	D <sub>1</sub>	(D <sub>2</sub> )	Weight	Box
170-099-428	YHS-32	32	90	1.5	3.5	7	45g	200pcs
170-099-427	YHS-38	38	82	1.2	3	6	35g	250pcs
170-099-426	YHS-51	51	116	1.5	4	7.5	85g	100pcs

**BUTT HINGE**

**HQ**

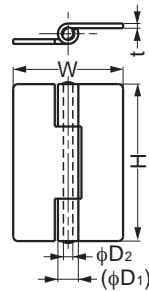

Item Code	Item Name	Material	Finish	H	W	(D <sub>1</sub> )	D <sub>2</sub>	t
170-099-465	HQ-50Y	Steel	Yellow Zinc Chromate	50	35	6.5	3	1.6
170-099-464	HQ-60Y	Steel	Yellow Zinc Chromate	60	50	8.5	4	2
170-099-463	HQ-68Y	Steel	Yellow Zinc Chromate	68	50	8.5	4	2
170-090-508	HQ-50C	Stainless Steel(SUS304)	Plain	50	35	6.5	3	1.5
170-090-513	HQ-60C	Stainless Steel(SUS304)	Plain	60	50	8.5	4	2
170-095-539	HQ-68C	Stainless Steel(SUS304)	Plain	68	50	8.5	4	2

**BUTT HINGE**



**DH-60RC**

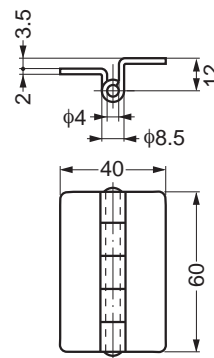

Item Code	Item Name	Material	Finish	Weight
170-090-329	DH-60RC	Stainless Steel(SUS304)	Plain	61g

# BUTT HINGE



**DH60N**

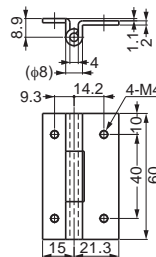

Item Code	Item Name	Material	Finish	Weight	Box
170-099-128	DH60N	Stainless Steel(SUS304)	Plain	51.2g	150pcs

# BUTT HINGE



**DH60**

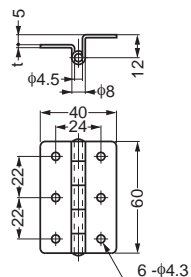

Item Code	Item Name	Material	Finish	t	Holes	Weight
170-090-325	☆DH-60A	Steel	Plain	1.6	without	53g
170-098-159	DH-60C	Stainless Steel(SUS304)	Mirror	1.5	with	52g

☆Limited stock available. Please contact your vendor.

# BUTT HINGE



**AS-HG-IS**

• Designed for aluminum profiles.

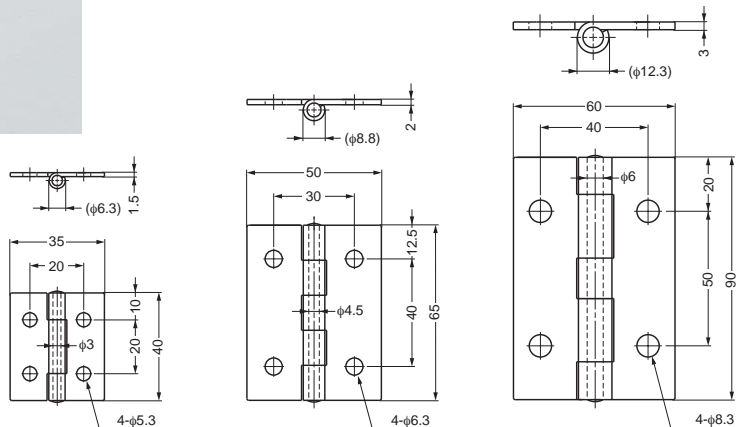

Item Code	Item Name	Material	Finish	Box	Carton
170-098-116	AS-HG-IS40	Stainless Steel(SUS304)	Polished	100pcs	400pcs
170-098-117	AS-HG-IS65	Stainless Steel(SUS304)	Polished	50pcs	200pcs
170-098-118	AS-HG-IS90	Stainless Steel(SUS304)	Polished	10pcs	80pcs

# CLEAN ROOM HINGE (W/BUSHING)



## HG-CV

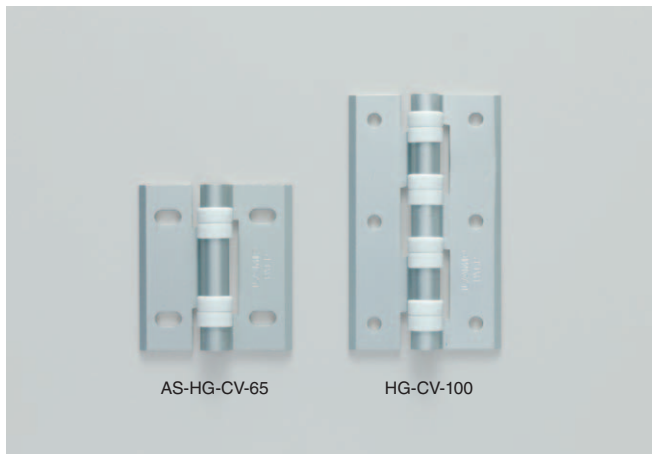

- No metal-to-metal contact.
- Polyacetal bushings minimize particles.
- Ideal for cleanroom application.
- Door weight:  
HG-CV- 65 Max. 8kg/pair.  
HG-CV-100 Max. 13kg/pair.
- Door size: Max. W600xH800.

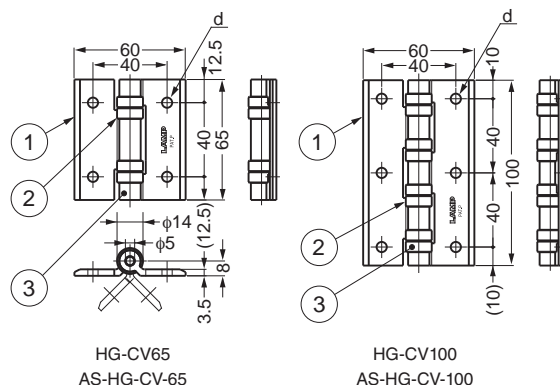

Item Code	Item Name	Spec.	d	Weight	Box	Carton
170-091-441	HG-CV-65	Round Hole	φ 5.5	50g	20pcs	240pcs
170-091-442	HG-CV-100	Round Hole	φ 5.5	78g	20pcs	160pcs
170-090-537	AS-HG-CV-65	Oval Hole	5.5x10.5	49g	20pcs	240pcs
170-090-540	AS-HG-CV-100	Oval Hole	5.5x10.5	76g	20pcs	160pcs

No.	Part Name	Material	Finish/Color
①	Body	Aluminum Alloy	Anodized
②	Bushing	Polyacetal	White
③	Hinge Pin	Stainless Steel(SUS303)	-

# CLEAN ROOM HINGE (W/BUSHING)



## HG-CV65N



- No metal-to-metal contact.
- Polyacetal bushings minimize particles.
- Ideal for cleanroom application.
- Door weight:Max.8kg/pair.
- Door size:Max.W600xH800.

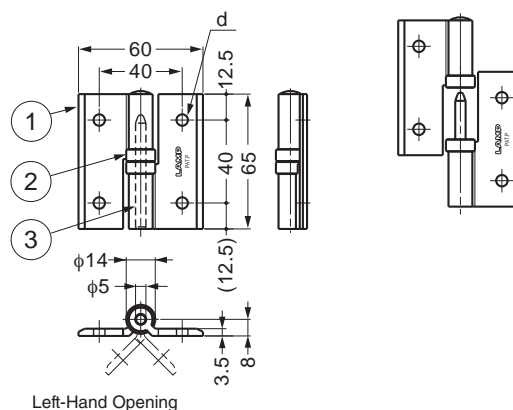

Item Code	Item Name	Spec.	d	Weight	Box	Carton
170-091-452	HG-CV-65NR	Right.Round Hole	φ 5.5	49g	20pcs	240pcs
170-091-451	HG-CV-65NL	Left.Round Hole	φ 5.5	49g	20pcs	240pcs
170-090-538	AS-HG-CV-65NR	Right.Oval Hole	5.5x10.5	48g	20pcs	240pcs
170-090-539	AS-HG-CV-65NL	Left.Oval Hole	5.5x10.5	48g	20pcs	240pcs

No.	Part Name	Material	Finish/Color
①	Body	Aluminum Alloy	Anodized
②	Bushing	Polyacetal	White
③	Hinge Pin	Stainless Steel(SUS303)	-

# HEAVY DUTY CLEAN ROOM HINGE



## HG-CV-127



HG-CV-127R

- No metal-to-metal contact.
- Special bearings minimize particles.
- Successfully passed 1,000,000 cycle test at the following door size.
  - Door Weight: MAX.100kg/pair.
  - Door Height: MAX.2,000mm.
  - Door Width: MAX.900mm.

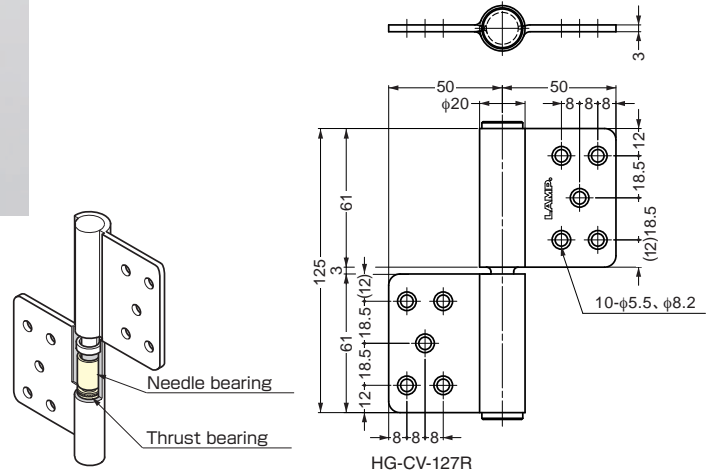
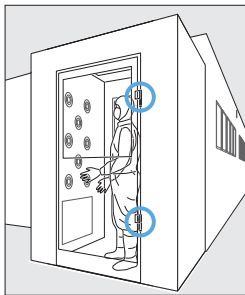

Item Code	Item Name	Spec.	Material	Finish	Weight	Box	Carton
170-013-013	HG-CV-127L	Left	Stainless Steel (SUS304)	Satin	388g	5pcs	50pcs
170-014-422	HG-CV-127R	Right	Stainless Steel (SUS304)	Satin	388g	5pcs	50pcs

# CLEAN ROOM HINGE

## HG-P100



- Made with PVC material: - Ideal for semiconductor manufacturing machinery and transparent applications. - Weather proof, chemical proof.
- Environmentally friendly - Lead free.
- Titanium pin is used.
- Recommended fastening torque 2.0N·m.

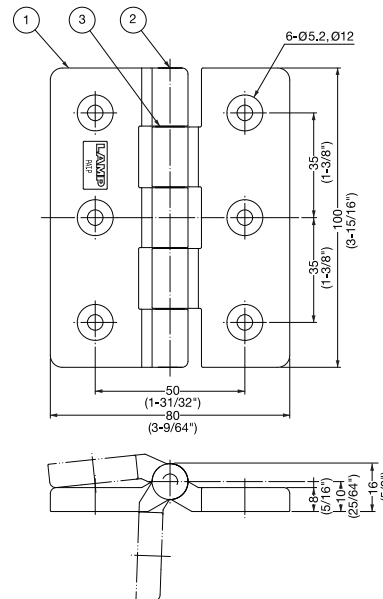

Item Code	Item Name	Weight	Box	Carton
170-020-836	HG-P100	74g	30pcs	240pcs

Material	Finish
Body	PVC
Hinge Pin	Titanium

# BUTT HINGE



## AS-HG-AL



- Designed for aluminum profiles.
- Plastic bushes provides smooth movement.

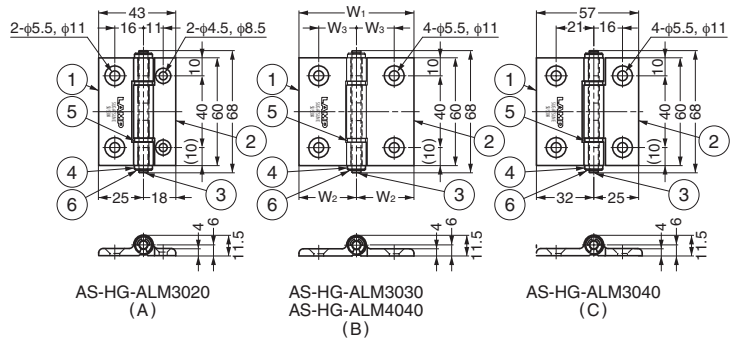

Item Code	Item Name	Material	Finish	Figure	W <sub>1</sub>	W <sub>2</sub>	W <sub>3</sub>	Box	Carton
170-011-679	AS-HG-ALM3020	Aluminum Alloy	Matte Silver	A		–		20pcs	300pcs
170-011-680	AS-HG-ALM3030	Aluminum Alloy	Matte Silver	B	50	25	16	20pcs	300pcs
170-011-681	AS-HG-ALM3040	Aluminum Alloy	Matte Silver	C		–		20pcs	300pcs
170-011-682	AS-HG-ALM4040	Aluminum Alloy	Matte Silver	B	64	32	21	20pcs	300pcs

# BUTT HINGE



## AS-HG-SUS



- Designed for aluminum profiles.
- Plastic bushes provides smooth movement.

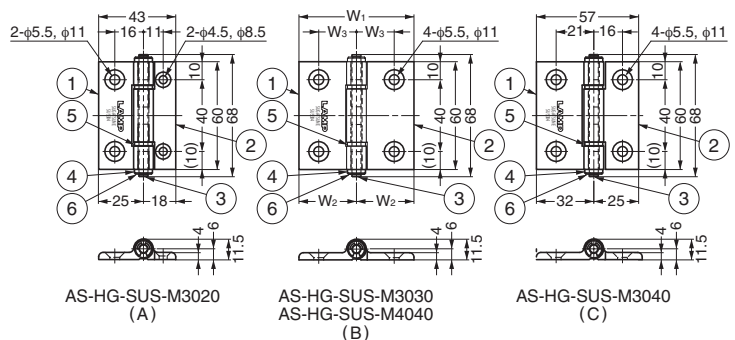

Item Code	Item Name	Material	Finish	Figure	W <sub>1</sub>	W <sub>2</sub>	W <sub>3</sub>	Box	Carton
170-011-886	AS-HG-SUS-M3020	Stainless Steel(SUS304)	Mirror	A		–		10pcs	100pcs
170-011-887	AS-HG-SUS-M3030	Stainless Steel(SUS304)	Mirror	B	50	25	16	10pcs	100pcs
170-011-888	AS-HG-SUS-M3040	Stainless Steel(SUS304)	Mirror	C		–		10pcs	100pcs
170-011-889	AS-HG-SUS-M4040	Stainless Steel(SUS304)	Mirror	B	64	32	21	10pcs	100pcs

# LIFT-OFF HINGE



## AS-HG-AL-N

- Designed for aluminum profiles.
- Plastic bushes provides smooth movement.



Fixing nut, See Page.25

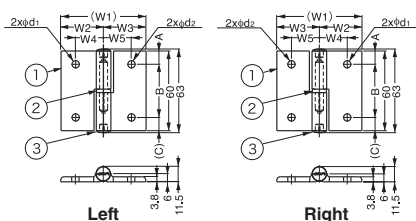
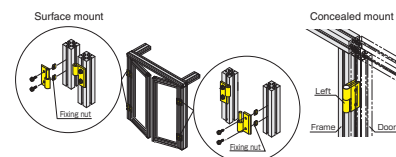

No.	Part Name	Material	Finish
①	Body	Aluminum Alloy	Matte Silver
②	Shaft	Stainless Steel(SUS303), Polyacetal(POM)	White(POM)
③	Cover	Polyacetal(POM)	White

Item Code	Item Name	Spec.	Holes	W1	W2	W3	W4	W5	d1	d2	A	B	C
170-018-210	AS-HG-AL-NL3020	Left	With	43	18	25	11	16	4.5	5.5	10	40	10
170-018-209	AS-HG-AL-NR3020	Right	With	43	18	25	11	16	4.5	5.5	10	40	10
170-018-212	AS-HG-AL-NL3030	Left	With	50	25	25	16	16	5.5	5.5	10	40	10
170-018-211	AS-HG-AL-NR3030	Right	With	50	25	25	16	16	5.5	5.5	10	40	10
170-018-214	AS-HG-AL-NL3040	Left	With	57	25	32	16	21	5.5	5.5	10	40	10
170-018-213	AS-HG-AL-NR3040	Right	With	57	25	32	16	21	5.5	5.5	10	40	10
170-018-216	AS-HG-AL-NL4040	Left	With	64	32	32	21	21	5.5	5.5	10	40	10
170-018-215	AS-HG-AL-NR4040	Right	With	64	32	32	21	21	5.5	5.5	10	40	10
170-020-684	AS-HG-AL-NL3020N	Left	Without	43	18	25	—	—	—	—	—	—	—
170-020-685	AS-HG-AL-NR3020N	Right	Without	43	18	25	—	—	—	—	—	—	—
170-020-686	AS-HG-AL-NL3030N	Left	Without	50	25	25	—	—	—	—	—	—	—
170-020-687	AS-HG-AL-NR3030N	Right	Without	50	25	25	—	—	—	—	—	—	—

# PIVOT HINGE



## AS-AF-25D

- Designed for aluminum profiles.
- Vertically and Horizontally adjustable for better compression.

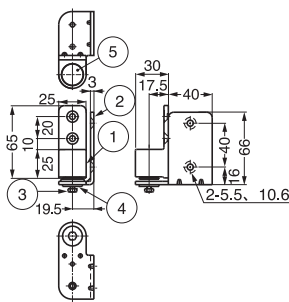

Item Code	Item Name	Door Width	Door Height	Door Thickness	Door Weight
170-090-693	AS-AF-25D	Max.900	Max.2200	33~ 42	Max.35kg

No.	Part Name	Material	Finish
①	Body	Aluminum Alloy	Matte Silver
②	Bracket	Stainless Steel(SUS304)	Polished
③	Fall-preventing bolt	Stainless Steel(SUS304)	—
④	Fall-preventing plate	Stainless Steel(SUS304)	—
⑤	Cover	ABS Plastic	Grey

### Vertical Adjustment

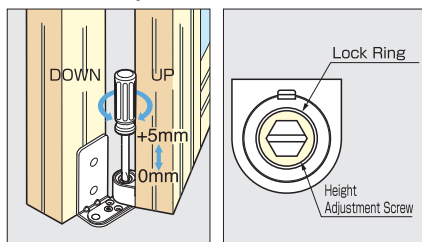

### Lateral Adjustment

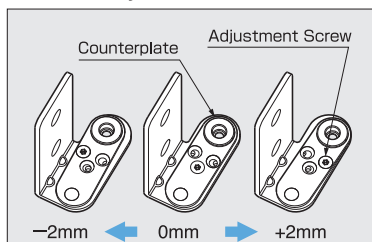

### Safety screw

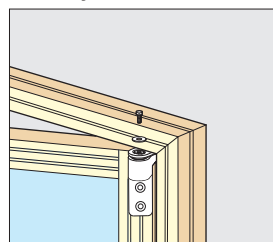

### Easy Door Installation

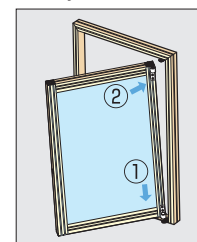

MonoFlat LIN-X hinge™

LIN-X450,600

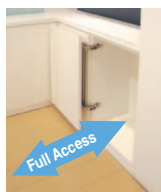

	LIN-X450	LIN-X600
Door Width	400 ~ 500mm	550 ~ 650mm
Door Height	600~2400mm	
Door Thickness	15~24mm	
Door Weight	Max. 17kg / Door	Max. 24kg / Door

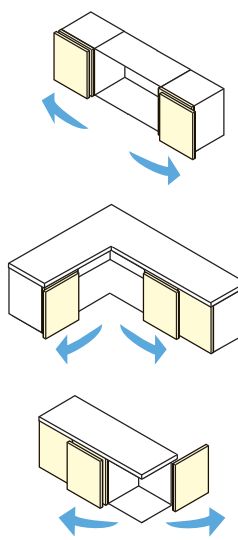
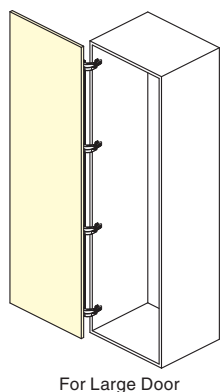
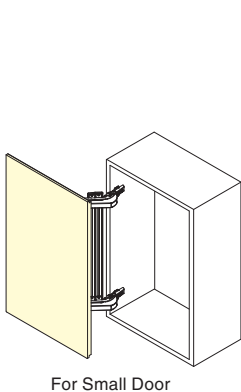







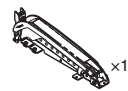

- Lateral Swing Mechanism Allows to swing out laterally in small radius, ideal for tight front space application.
- Full access to cabinet Door will not get in the way when fully opened providing full access to the cabinet.
- Free swing & soft-close.
- Easy Installation.
- 4-way Adjustable.
- Various Applications - Corner use, double door use & overlapped door use.

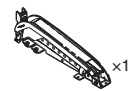
\* Please note handle position on other doors before installation, so that hinges will not interfere with the handles.

MonoFlat LIN-X hinge™

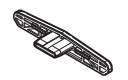
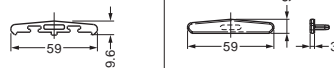
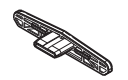
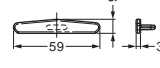
LIN-X450

Item Code	Item Name	Door Height	Door Weight	Parts Details for LIN-X450			
				Hinge set (With Damper) Item Name : LIN-X450ACD	Hinge set (Without Damper) Item Name : LIN-X450A	Connecting Bar Item Name : LIN-X45-Lxxx	End cap for Connecting Bar (Item Name : LIN-X45C)
				 x1  x1  x4	 x1  x1  x4	  	 
Necessary Quantity							
250-016-701	LIN-X450S-0907	600 ~ 900mm	Less than 7kg	2 sets	—	540mm x 1pc	2 pcs
250-016-702	LIN-X450S-0910	900mm	7.1 ~ 10.5kg	3 sets	—	540mm x 1pc	2 pcs
250-016-704	LIN-X450S-1210	901 ~ 1200mm	7.1 ~ 10.5kg	3 sets	—	840mm x 1pc	2 pcs
250-016-705	LIN-X450S-1214	1200mm	10.6 ~ 14kg	3 sets	1 set	840mm x 1pc	2 pcs
250-016-707	LIN-X450S-1510	1201 ~ 1500mm	7.1 ~ 10.5kg	3 sets	—	1140mm x 1pc	2 pcs
250-016-708	LIN-X450S-1514	1500mm	10.6 ~ 14kg	3 sets	1 set	1140mm x 1pc	2 pcs
250-016-709	LIN-X450S-1517	1501 ~ 1800mm	14.1 ~ 17kg	3 sets	2 sets	1140mm x 1pc	2 pcs
250-016-711	LIN-X450S-1810	1800mm	7.1 ~ 10.5kg	3 sets	—	1440mm x 1pc	2 pcs
250-016-712	LIN-X450S-1814	1801 ~ 2100mm	10.6 ~ 14kg	3 sets	1 set	1440mm x 1pc	2 pcs
250-016-713	LIN-X450S-1817	2100mm	14.1 ~ 17kg	3 sets	2 sets	1440mm x 1pc	2 pcs
250-016-716	LIN-X450S-2110	1801 ~ 2100mm	7.1 ~ 10.5kg	3 sets	—	1740mm x 1pc	2 pcs
250-016-717	LIN-X450S-2114	2100mm	10.6 ~ 14kg	3 sets	1 set	1740mm x 1pc	2 pcs
250-016-718	LIN-X450S-2117	2101 ~ 2400mm	14.1 ~ 17kg	3 sets	2 sets	1740mm x 1pc	2 pcs
250-016-723	LIN-X450S-2414	2400mm	10.6 ~ 14kg	3 sets	1 set	2040mm x 1pc	2 pcs
250-016-724	LIN-X450S-2417	2401 ~ 2400mm	14.1 ~ 17kg	3 sets	2 sets	2040mm x 1pc	2 pcs

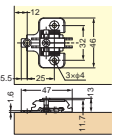
Item Code	Item Name	Parts	Drawing	Specification
160-070-041	230-P4W-32T	 Mounting Plate		Material : Steel Finish : Nickel  Same quality with hinge is necessary

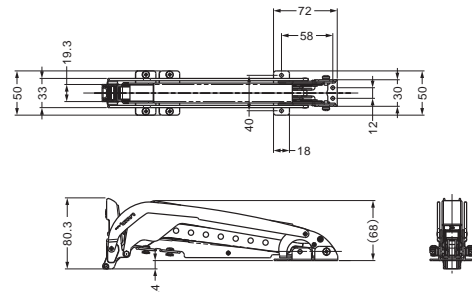

Cup Cover

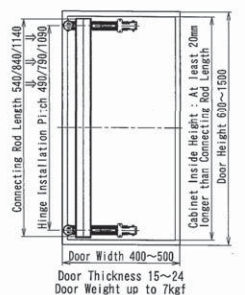
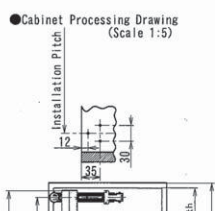
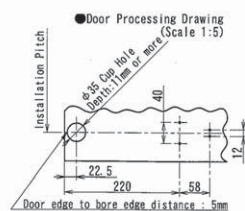
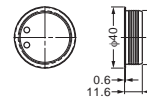

2 Hinges per door  
①Damper and Catch Hinges : 2 pcs

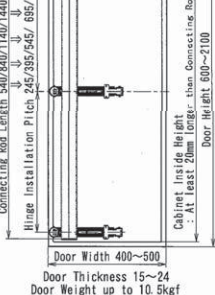

3 Hinges per door  
①Damper and Catch Hinges : 3 pcs

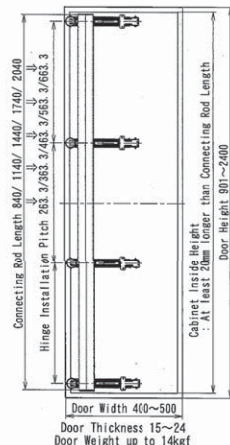

4 Hinges per door  
①Damper and Catch Hinges : 3 pcs  
②Non Damper and Catch Hinges : 1pc  
\*Please install the ② to the second place from the bottom.

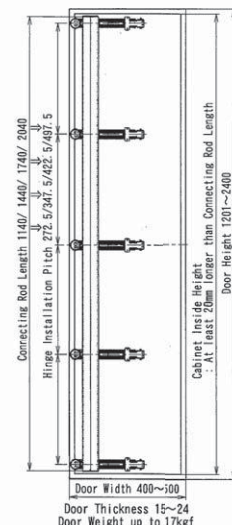



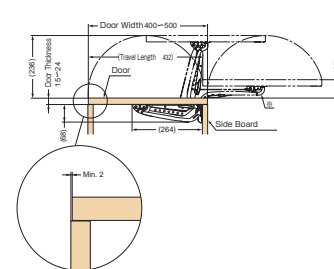

5 Hinges per door  
①Damper and Catch Hinges : 3 pcs  
②Non Damper and Catch Hinges : 2pc  
\*Please install the ② to the 2nd and 3rd place from the bottom.



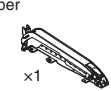

MonoFlat LIN-X hinge™

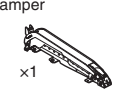
LIN-X600

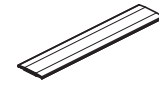
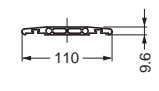
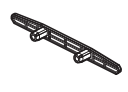
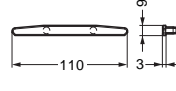
Item Code	Item Name	Door Height	Door Weight	Parts Details for LIN-X600			
				Hinge set (With Damper) Item Name : LIN-X600ACD	Hinge set (Without Damper) Item Name : LIN-X600A	Connecting Bar Item Name : LIN-X60-Lxxx	End cap for Connecting Bar (Item Name : LIN-X60C)
				Hinge Body with Damper  x1 Hole Cover  x1  x4 Screws (3.5x15) Material : Steel Finish : Nickel	Hinge Body without Damper  x1 Hole Cover  x1  x4 Screws (3.5x15) Material : Steel Finish : Nickel	  Material : Aluminum Alloy Finish : Anodized	  Material : Polyacetal
Necessary Quantity							
250-017-492	LIN-X600S-0909	600 ~ 900mm	Less than 9kg	2 sets	—	540mm x 1pc	2 pcs
250-017-067	LIN-X600S-0912	900mm	9.1 ~ 12kg	3 sets	—	540mm x 1pc	2 pcs
250-017-068	LIN-X600S-1212	901 ~ 1200mm	Less than 12kg	2 sets	—	840mm x 1pc	2 pcs
250-017-069	LIN-X600S-1216	1200mm	12.1 ~ 16kg	3 sets	1 set	840mm x 1pc	2 pcs
250-017-071	LIN-X600S-1516	1201 ~ 1500mm	Less than 16kg	3 sets	—	1140mm x 1pc	2 pcs
250-017-072	LIN-X600S-1520	1500mm	16.1 ~ 20kg	3 sets	1 set	1140mm x 1pc	2 pcs
250-017-074	LIN-X600S-1816	1501 ~ 1800mm	Less than 16kg	3 sets	—	1440mm x 1pc	2 pcs
250-017-075	LIN-X600S-1820	1800mm	16.1kg ~ 20kg	3 sets	1 set	1440mm x 1pc	2 pcs
250-017-493	LIN-X600S-1824	1801 ~ 2100mm	20.1 ~ 24kg	3 sets	2 sets	1440mm x 1pc	2 pcs
250-017-077	LIN-X600S-2116	2100mm	Less than 16kg	3 sets	—	1740mm x 1pc	2 pcs
250-017-078	LIN-X600S-2120	2101 ~ 2400mm	16.1kg ~ 20kg	3 sets	1 set	1740mm x 1pc	2 pcs
250-017-079	LIN-X600S-2124	2400mm	20.1 ~ 24kg	3 sets	2 sets	1740mm x 1pc	2 pcs
250-017-082	LIN-X600S-2420	2401 ~ 2700mm	Less than 20kg	3 sets	1 set	2040mm x 1pc	2 pcs
250-017-083	LIN-X600S-2424	2700mm	20.1 ~ 24kg	3 sets	2 sets	2040mm x 1pc	2 pcs

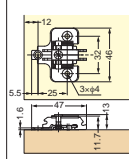
Item Code	Item Name	Parts	Drawing	Specification
160-070-041	230-P4W-32T			Material : Steel Finish : Nickel *Same quality with hinge is necessary

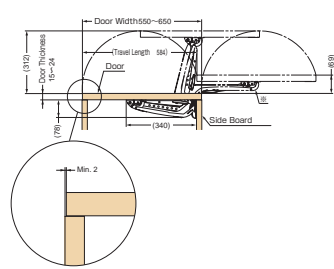
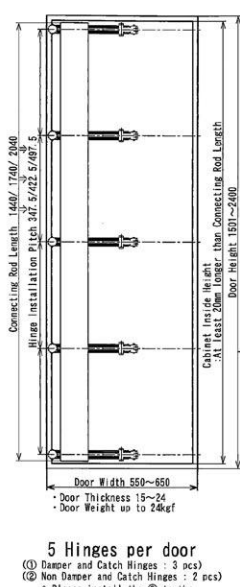
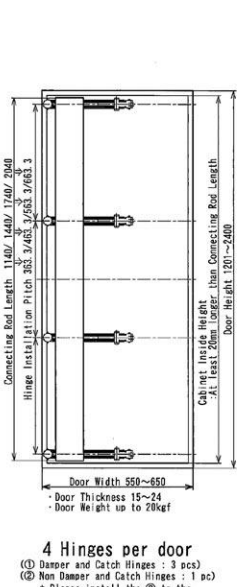
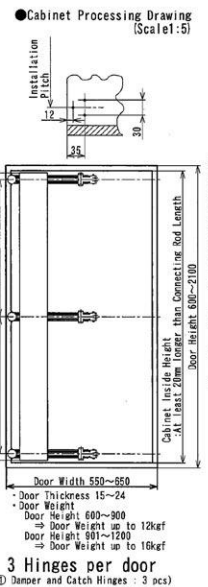
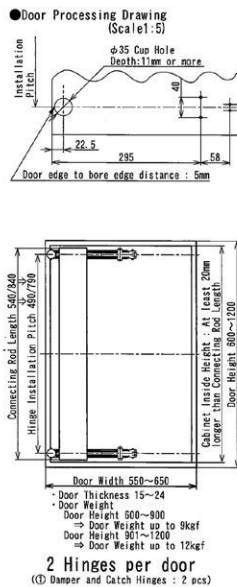
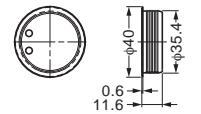
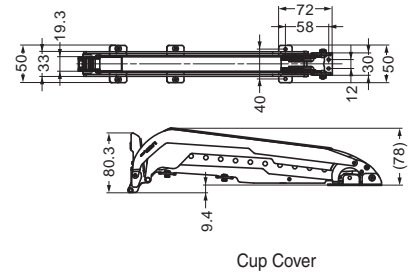

# LIFT-OFF HINGE



## LSW

• Handed: Specific left and right hand mounting.

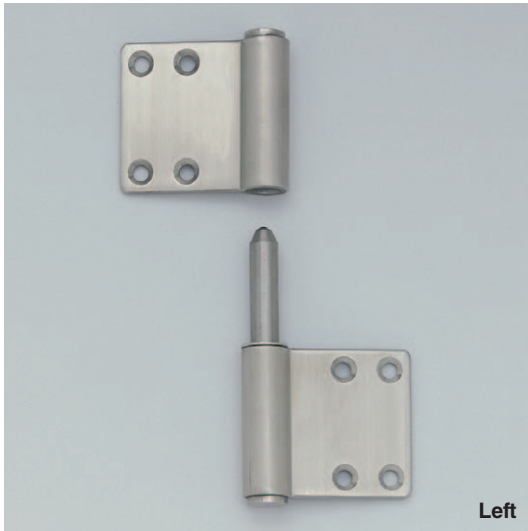

Left

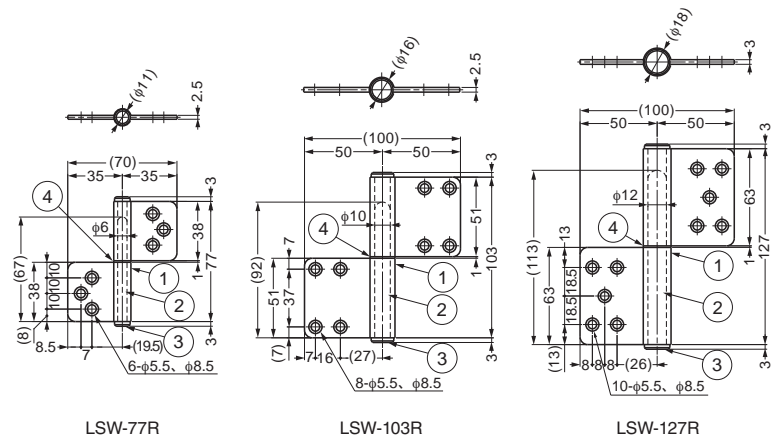

No.	Part Name	Material	Finish
①	Body	Stainless Steel(SUS304)	Satin
②	Shaft	Stainless Steel(SUS304)	Satin
③	Cover	Stainless Steel(SUS304)	—
④	Washer	Stainless Steel(SUS304)	—

Item Code	Item Name	Spec.	Weight	Box
170-090-344	LSW-77L	Left	95g	1pcs
170-090-345	LSW-77R	Right	95g	1pcs
170-090-493	LSW-103L	Left	300g	50pcs
170-090-494	LSW-103R	Right	300g	50pcs
170-090-491	LSW-127L	Left	370g	50pcs
170-090-492	LSW-127R	Right	370g	50pcs

# LIFT-OFF HINGE



## LSX

• Handed: Specific left and right hand mounting.



Right

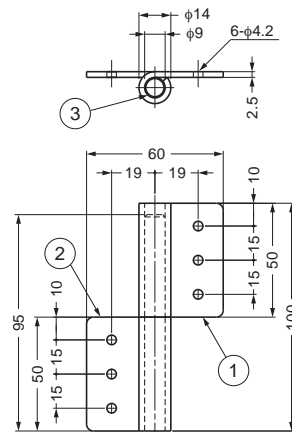

LSX-100R

No.	Part Name	Material	Finish
①	Body A	Stainless Steel(SUS304)	Mirror
②	Body B	Stainless Steel(SUS304)	Mirror
③	Shaft	Stainless Steel(SUS304)	—

Item Code	Item Name	Spec.	Weight	Box	Carton
170-090-341	LSX-100L	Left	170g	20pcs	80pcs
170-090-340	LSX-100R	Right	170g	20pcs	80pcs

# LIFT-OFF HINGE (WELD-ON)



**HNH**



Right

- Weld-on type lift-off hinge.
- Handed: Specific left and right hand mounting.

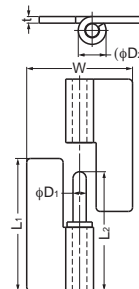

Item Code	Item Name	Spec.	Material	Finish	L <sub>1</sub>	L <sub>2</sub>	W	D <sub>1</sub>	D <sub>2</sub>	t	Weight	Box
170-091-056	HNH-50CL	Left	Stainless Steel(SUS304)	Mirror	50	45	40	5	10.5	2.5	60g	30pcs
170-091-057	HNH-50CR	Right	Stainless Steel(SUS304)	Mirror	50	45	40	5	10.5	2.5	60g	30pcs
170-091-054	HNH-65CL	Left	Stainless Steel(SUS304)	Mirror	65	60	50	5	10.5	2.5	89g	20pcs
170-091-055	HNH-65CR	Right	Stainless Steel(SUS304)	Mirror	65	60	50	5	10.5	2.5	89g	20pcs
170-091-052	HNH-75CL	Left	Stainless Steel(SUS304)	Mirror	75	70	70	6	12	3	165g	10pcs
170-091-053	HNH-75CR	Right	Stainless Steel(SUS304)	Mirror	75	70	70	6	12	3	165g	10pcs
170-091-050	HNH-100CL	Left	Stainless Steel(SUS304)	Mirror	100	90	82	8	16	4	347g	5pcs
170-091-051	HNH-100CR	Right	Stainless Steel(SUS304)	Mirror	100	90	82	8	16	4	347g	5pcs

# LIFT-OFF HINGE



**KN**



Right

- Handed: Specific left and right hand mounting.

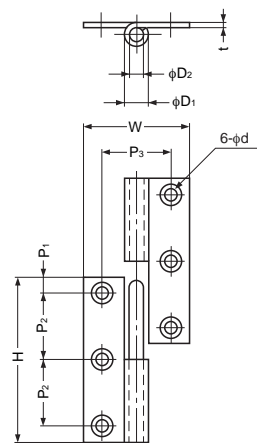

Item Code	Item Name	Spec.	Holes	Material	H	W	P <sub>1</sub>	P <sub>2</sub>	P <sub>3</sub>	D <sub>1</sub>	D <sub>2</sub>	d	t	Weight	Box	Carton
170-090-742	KN-50CL	Left	With	Stainless Steel (SUS304)	50	32	5	20	21	7.5	4	3.2	1.5	30g	100pcs	400pcs
170-090-743	KN-50CR	Right	With	Stainless Steel (SUS304)	50	32	5	20	21	7.5	4	3.2	1.5	30g	100pcs	400pcs
170-090-744	KN-64CL	Left	With	Stainless Steel (SUS304)	64	36	8	24	24	7.5	4	3.2	1.5	38g	100pcs	400pcs
170-090-745	KN-64CR	Right	With	Stainless Steel (SUS304)	64	36	8	24	24	7.5	4	3.2	1.5	38g	100pcs	400pcs
170-090-746	KN-75CL	Left	With	Stainless Steel (SUS304)	75	38	7.5	30	24	8.5	4	3.2	2	60g	50pcs	200pcs
170-090-747	KN-75CR	Right	With	Stainless Steel (SUS304)	75	38	7.5	30	24	8.5	4	3.2	2	60g	50pcs	200pcs

# LIFT-OFF HINGE



## SNR65



Right

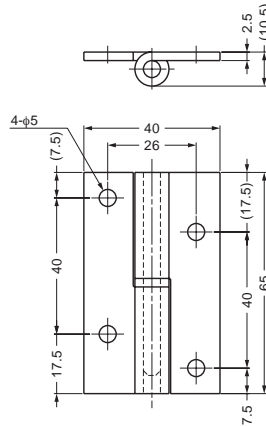

- Handed: Specific left and right hand mounting.

Item Code	Item Name	Spec.	Material	Finish	Weight	Box
170-099-046	SNR65L	Left	Stainless Steel(SUS304)	Plain	76.2g	100pcs
170-099-043	SNR65R	Right	Stainless Steel(SUS304)	Plain	76.2g	100pcs

# LIFT-OFF HINGE



## SNRK65



Right

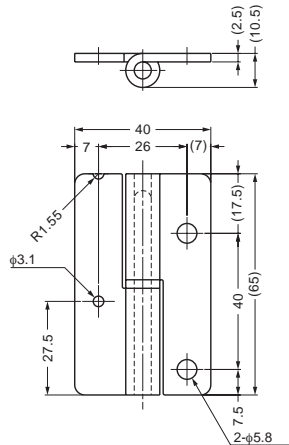

- Handed: Specific left and right hand mounting.

Item Code	Item Name	Spec.	Material	Finish	Weight	Box
170-099-084	SNRK65L	Left	Stainless Steel(SUS304)	Plain	75g	150pcs
170-099-085	SNRK65R	Right	Stainless Steel(SUS304)	Plain	75g	150pcs

# LIFT-OFF HINGE



## NH-40



Left

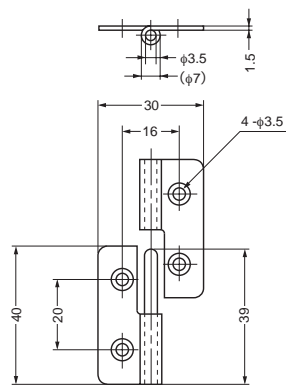

- Handed: Specific left and right hand mounting.

Item Code	Item Name	Spec.	Holes	Material	Finish	Weight	Box
170-090-334	NH-40AL	Left	Without	Steel	Clear Zinc Chromate	21g	50pcs
170-090-332	NH-40AR	Right	Without	Steel	Clear Zinc Chromate	21g	50pcs
170-090-338	NH-40CL	Left	With	Stainless Steel(SUS304)	Polished	21g	150pcs
170-090-336	NH-40CR	Right	With	Stainless Steel(SUS304)	Polished	21g	150pcs

# LIFT-OFF HINGE



BN

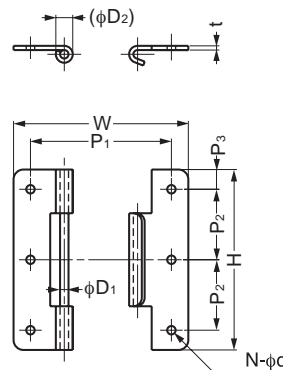

Item Code	Item Name	Material	Finish	H	W	P <sub>1</sub>	P <sub>2</sub>	P <sub>3</sub>	φ d	φ D <sub>1</sub>	(φ D <sub>2</sub> )	t	N	Weight	Box
170-099-770	BN-30S	Stainless Steel(SUS304)	Polished	30	25	18	21	4.5	3	2	4	1	4	2g	600pcs
170-099-769	BN-36S	Stainless Steel(SUS304)	Polished	36	32	20	13	5	3	2	4	1	6	3g	400pcs
170-099-499	BN-40S	Stainless Steel(SUS304)	Polished	40	36	24	15	5	3	2.5	4.5	1	6	4g	300pcs
170-099-498	BN-50S	Stainless Steel(SUS304)	Polished	50	30	20	20	5	3	3	6	1.5	6	6g	200pcs
170-099-497	BN-64S	Stainless Steel(SUS304)	Polished	64	36	24	25	7	3	3	6	1.5	6	8g	150pcs

# LIFT-OFF HINGE

SKH



SKH-60CR

SKH-51S

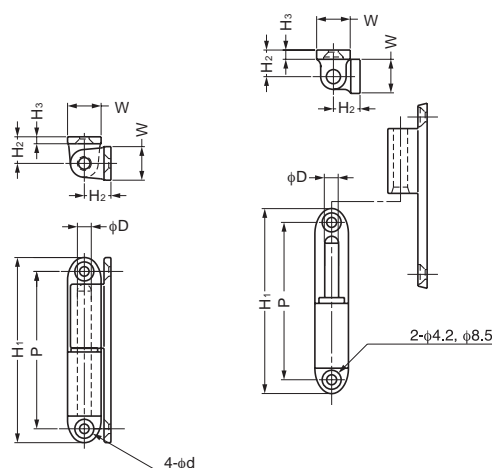

Item Code	Item Name	Material	Finish	H <sub>1</sub>	H <sub>2</sub>	H <sub>3</sub>	W	P	φ D	d	Weight	Box
170-099-345	SKH-35S	Stainless Steel(SUS304)	Mirror	35	6	2	8	27	3	M3	12g	—
170-099-129	SKH-51S	Stainless Steel(SUS304)	Mirror	51	8	2.5	11	40	4	M3	30g	—
170-090-818	SKH-60S	Stainless Steel(SUS304)	Mirror	60	9.5	3	13	48	5	M4	50g	—
170-099-328	SKH-80S	Stainless Steel(SUS304)	Mirror	80	11.5	4.5	14.5	68	6	M4	95g	—
170-090-473	SKH-35CR	Zinc Alloy	Chrome	35	6	2	8	27	3	M3	12g	200pcs
170-099-768	SKH-51CR	Zinc Alloy	Chrome	51	8	2.5	11	40	4	M3	30g	150pcs
170-099-474	SKH-60CR	Zinc Alloy	Chrome	60	9.5	3	13	48	5	M4	50g	100pcs
170-099-473	SKH-80CR	Zinc Alloy	Chrome	80	11.5	4	14.5	68	6	M4	95g	50pcs

# LIFT-OFF HINGE (WELD-ON)



## S-6166-2

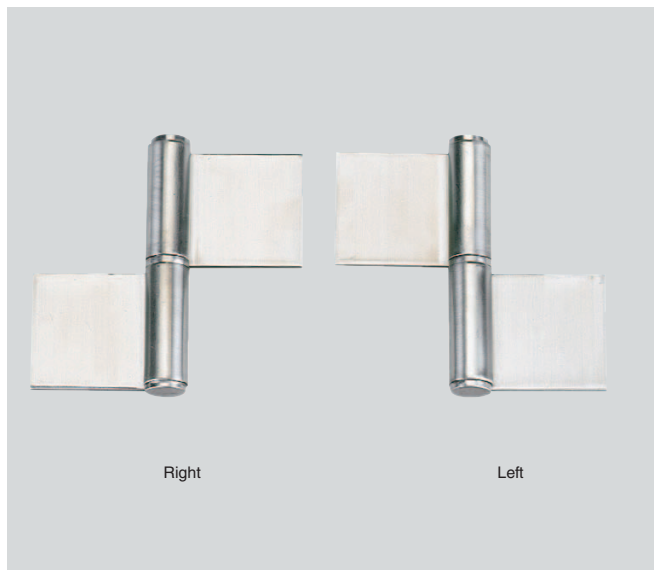

- Weld-on type stainless steel lift-off hinge.
- Handed: Specific left and right hand mounting.
- Door weight: Max. 40kg/pair.

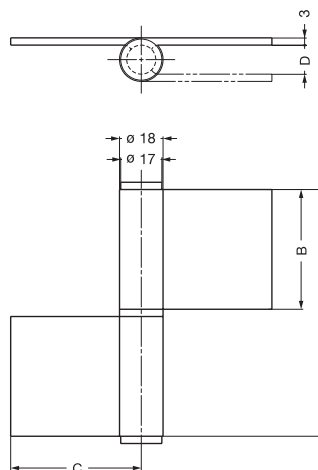

Material	Finish
304 Stainless Steel	Satin

Item Code	Item Name	Spec.	A	B	C	D	Weight	Box	Carton
170-099-400	S-6166-2-L	Left	102 (4-1/64")	49.5 (1-61/64")	55 (2-5/32")	12 (15/32")	300g	12pcs	60pcs
170-099-401	S-6166-2-R	Right							

# LIFT-OFF HINGE (WELD-ON)



## S-6166-6

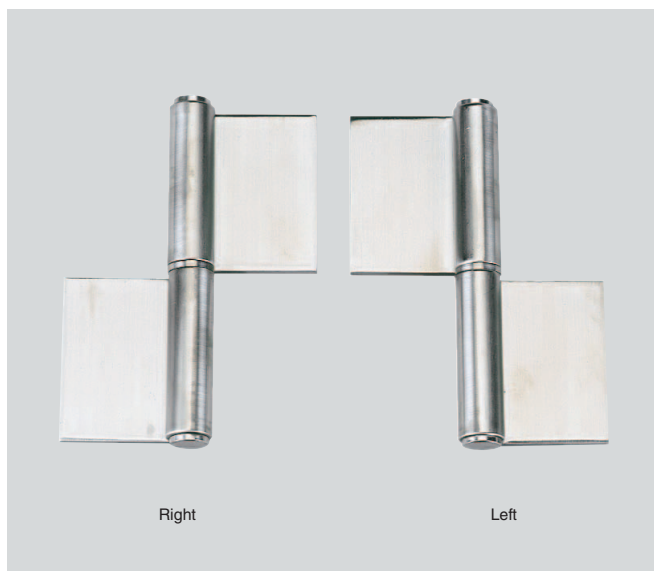

- Weld-on type stainless steel lift-off hinge.
- Handed: Specific left and right hand mounting.
- Door weight: Max. 90kg/pair.

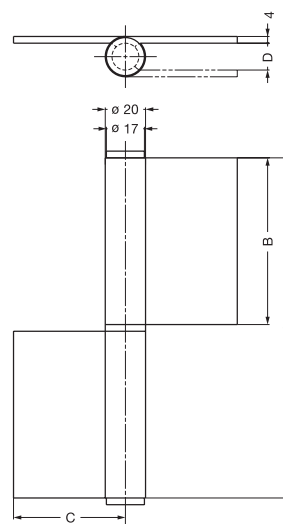

Material	Finish
304 Stainless Steel	Satin

Item Code	Item Name	Spec.	A	B	C	D	Weight	Box	Carton
170-099-402	S-6166-6-L	Left	152 (5-63/64")	74.5 (2-15/16")	55 (2-5/32")	12 (15/32")	570g	8pcs	40pcs
170-099-403	S-6166-6-R	Right							

# LIFT-OFF HINGE



## S-6173-2



- Screw hole is countersunk from both sides.
- Non-Handed: Can be installed on left or right side.
- Door weight: Max. 40kg/pair.

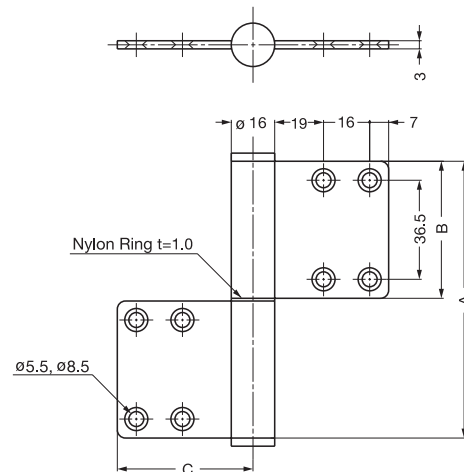

Material	Finish
304 Stainless Steel	Satin

Item Code	Item Name	A	B	C	Weight	Box	Carton
170-099-404	S-6173-2	102 (4-1/64")	50.5 (1-63/64")	50 (1-31/32")	240g	12pcs	60pcs

# LIFT-OFF HINGE



## S-6173-5

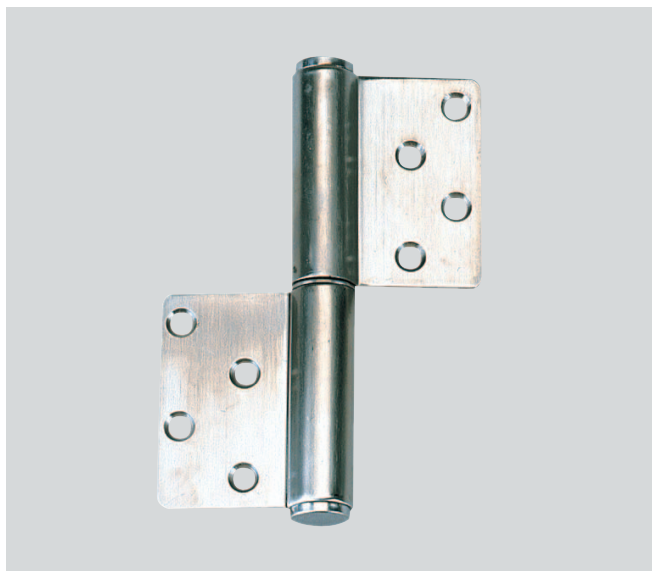

- Screw hole is countersunk from both sides.
- Non-Handed: Can be installed on left or right side.
- Door weight: Max. 50kg/pair.

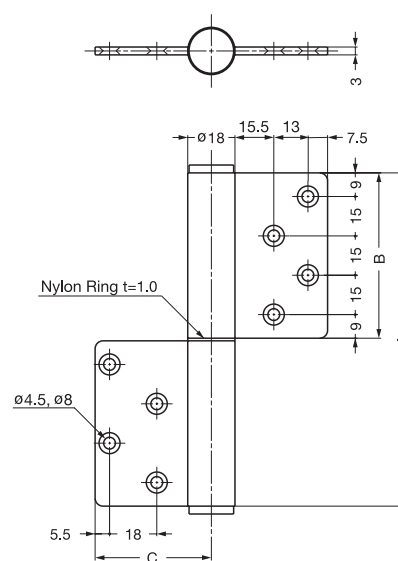

Material	Finish
304 Stainless Steel	Satin

Item Code	Item Name	A	B	C	Weight	Box	Carton
170-099-405	S-6173-5	127 (5")	63 (2-31/64")	45 (1-25/32")	330g	8pcs	40pcs

# QUICK RELEASE HINGE



## HG-OT

- Easy and quick to install/remove doors.
- With or without holes available.
- Non-Handed: Can be installed on left or right side.

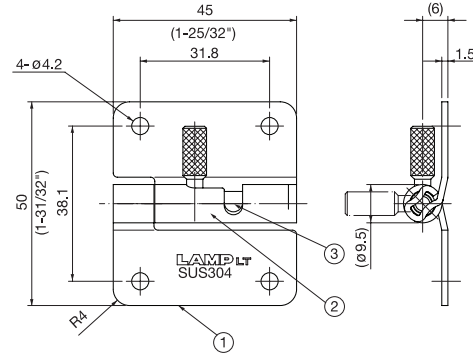
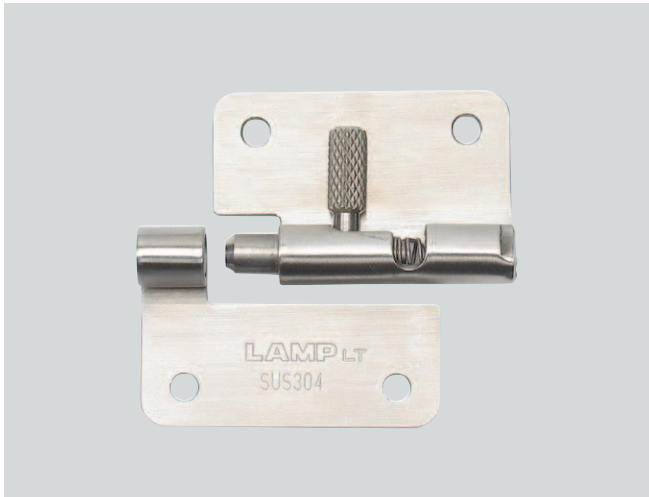

HG-OTA45L

Item Code	Item Name		Holes	Weight	Box	
	Left	Right				
170-090-945	170-090-944	HG-OTA45L	HG-OTA45R	With screw holes	40g	30pcs
170-090-947	170-090-946	HG-OTB45L	HG-OTB45R	Without screw holes		

No.	Part Name	Material	Finish
①	Plate	304 Stainless Steel	Satin
②	Spring		
③	Hinge Pin	303 Stainless Steel	

# QUICK RELEASE HINGE



## HG-OT

- Easy and quick to install/remove doors.
- With or without holes available.

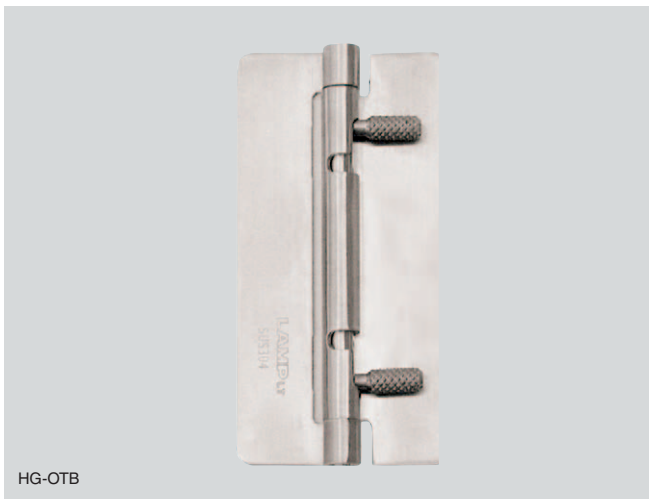

HG-OTB

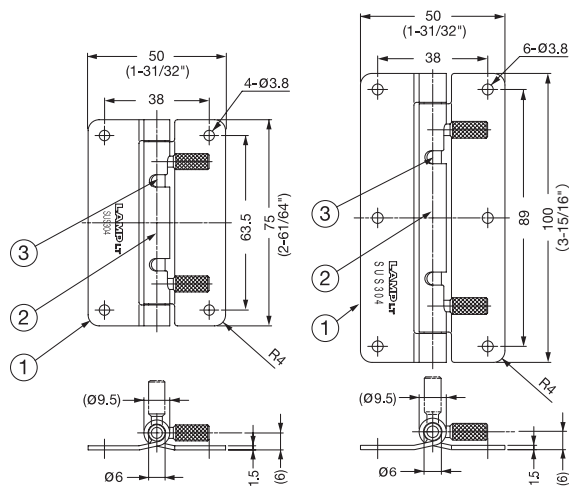

HG-OTA75

HG-OTA100

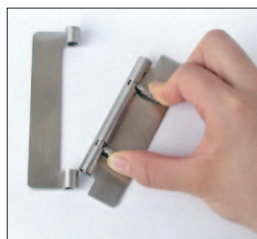

Item Code	Item Name	Holes	Weight	Box	Carton
170-090-942	HG-OTA75	With screw holes	65g	40pcs	160pcs
170-090-943	HG-OTB75	Without screw holes			
170-090-940	HG-OTA100	With screw holes	80g	30pcs	120pcs
170-090-941	HG-OTB100	Without screw holes			

No.	Part Name	Material	Finish
①	Plate	304 Stainless Steel	Satin
②	Spring		
③	Hinge Pin	303 Stainless Steel	



# PIVOT HINGE

# HG-PV-30C



- Easy and quick to remove doors.

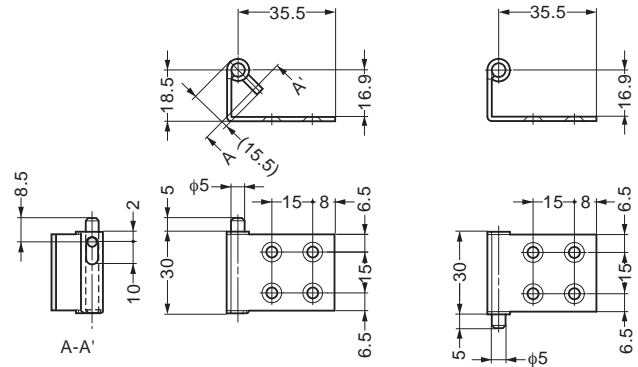

### Installation

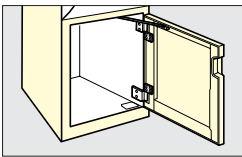

Item Code	Item Name	Material	Finish	Weight	Box	Carton
170-098-215	HG-PV-30C	Stainless Steel (SUS304)	Mirror	54g	100pcs	200pcs

# SPRING LOADED PIVOT HINGE



# HG-PV60AC



- Spring loaded for self closing.
- Lift pin for easy door installation and removal.
- Torsion moment (Hinge closed): 0.76 kgf-cm (0.66 lb-in) per piece.

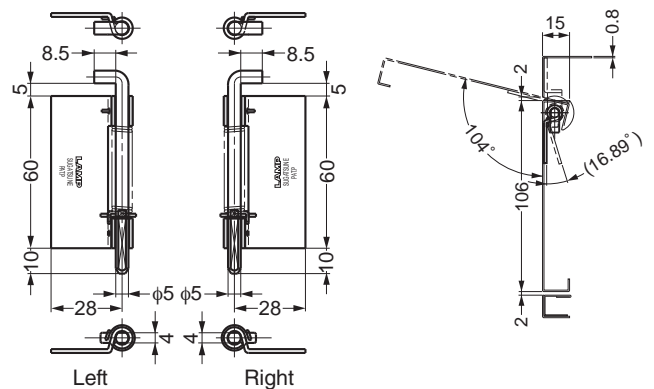

### Installation

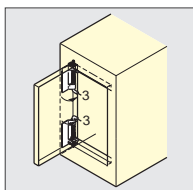
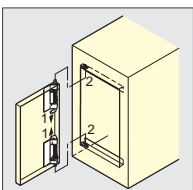

### Cut Out Dimensions

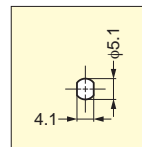

Item Code	Item Name	Spec.	Material	Finish	Door Weight	Weight	Box	Carton
170-090-988	HG-PV60AC-L	Left	Stainless Steel	Plain	2kg	38g	50pcs	200pcs
170-090-987	HG-PV60AC-R	Right	Stainless Steel	Plain	2kg	38g	50pcs	200pcs

# DOUBLE ACTION SPRING HINGE

# DA

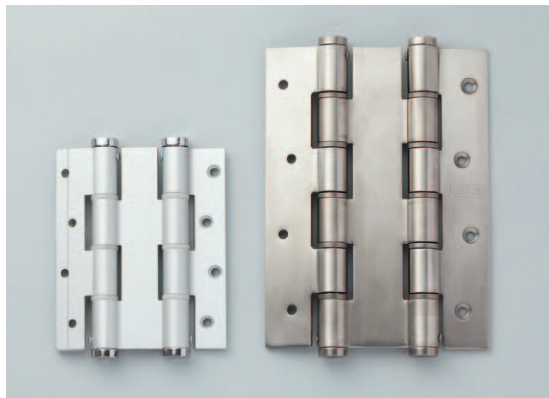

- Spring loaded for self closing.
- Adjustable spring tension.
- Stainless Steel construction suitable for harsh environments.

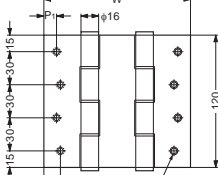
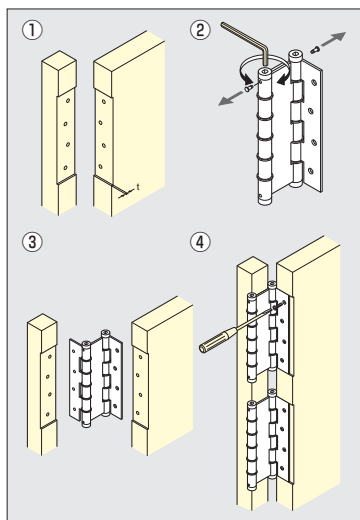

DA 120

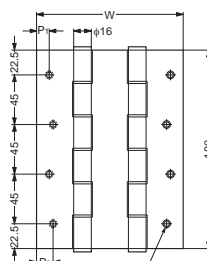

DA 180

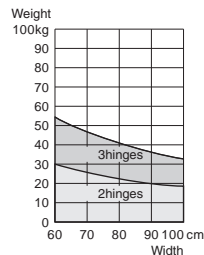

DA120-5404

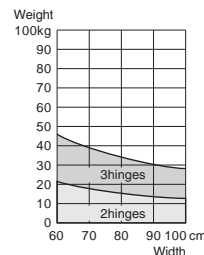

DA120-5414

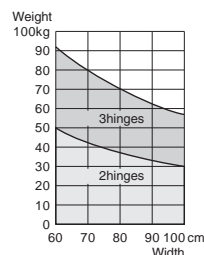

DA180-5904

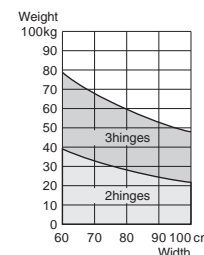

DA180-5914

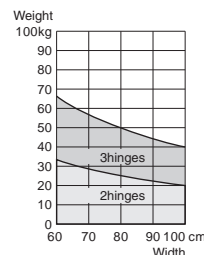

DA180-5934

Item Code	Item Name	Material	Finish	W	W <sub>1</sub>	W <sub>2</sub>	P <sub>1</sub>	P <sub>2</sub>	t	d <sub>1</sub>	d <sub>2</sub>	Door Thickness	Weight	Opening Angle	Box
170-090-803	DA120-5404-01	Aluminum Alloy	Anodized	101	29.5	42	6.5	11.5	4	5	8	Max.30	275g	180°	2pcs
170-090-804	DA120-5414-01	Aluminum Alloy	Anodized	133	40	53	11	16	4	5	8	Max.40	320g	180°	2pcs
170-090-805	DA120-5414-05	Stainless Steel(SUS304)	Plain	133	40	53	11	16	2.5	5.5	9	Max.36	555g	180°	2pcs
170-090-806	DA180-5904-01	Aluminum Alloy	Anodized	101	29.5	42	6.5	11.5	4	5	8	Max.30	407g	180°	2pcs
170-090-807	DA180-5914-01	Aluminum Alloy	Anodized	133	40	53	11	16	4	5	8	Max.40	466g	180°	2pcs
170-090-808	DA180-5914-05	Stainless Steel(SUS304)	Plain	133	40	53	11	16	3	5.5	9	Max.38	947g	180°	2pcs
170-090-809	DA180-5934-01	Aluminum Alloy	Anodized	157	48.5	60	19.5	24.5	4	5	8	Max.50	510g	180°	2pcs

# SPRING HINGE

# SA

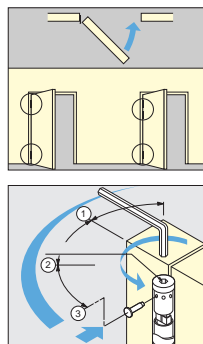

- Spring loaded for self closing.
- Adjustable spring tension.
- Stainless Steel construction suitable for harsh environments.

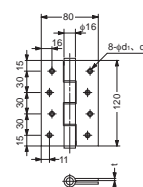

SA 120

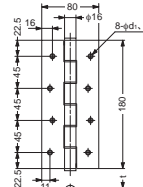

SA 180

Item Code	Item Name	Material	Finish	t	d <sub>1</sub>	d <sub>2</sub>	Load Capacity (Per 3pcs)	Load Capacity (Per 2pcs)	Weight	Box		
170-090-810	SA120-5314-01	Aluminum Alloy	Anodized	4	—	8	294N	30kgf	196N	20kgf	175g	2pcs
170-090-811	SA180-5814-01	Aluminum Alloy	Anodized	4	5	8	588N	60kgf	392N	40kgf	260g	2pcs
170-090-812	SA120-5314-05	Stainless Steel (SUS304)	Plain	2.5	—	9	294N	30kgf	196N	20kgf	303g	2pcs
170-090-813	SA180-5814-05	Stainless Steel (SUS304)	Plain	3	5.5	9	588N	60kgf	392N	40kgf	526g	2pcs

(\* )Load capacity for a door width of 1,000mm.

## BUTT HINGE (W/SPRING)



## HG-SH

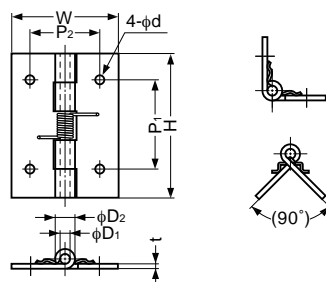

• Designed to keep doors closed.

Item Code	Item Name	Material	Finish	H	W	P <sub>1</sub>	P <sub>2</sub>	D <sub>1</sub>	D <sub>2</sub>	d	t	Torque Moment		Weight
170-098-515	HG-SH-20C	Stainless Steel(SUS304)	Mirror	20	14	—	—	1	2.2	—	0.5	9.7N · cm	0.99kgf · cm	1.5g
170-098-520	HG-SH-25C	Stainless Steel(SUS304)	Mirror	25	32	14	20	3	5.8	3.2	1.2	6.5N · cm	0.66kgf · cm	10g
170-098-521	HG-SH-38C	Stainless Steel(SUS304)	Mirror	38	32	26	20	3	6.5	3.2	1.5	14.7N · cm	1.5kgf · cm	20g
170-098-522	HG-SH-51C	Stainless Steel(SUS304)	Mirror	51	38	32	25	3	6.5	3.2	1.5	13.5N · cm	1.38kgf · cm	35g

## BUTT HINGE (W/SPRING)



## SH

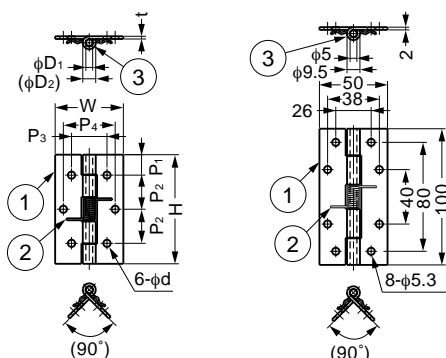

• Designed to keep doors closed.

No.	Part Name	Material	Finish
①	Body	Stainless Steel(SUS304)	Polished
②	Spring	Stainless Steel(SUS304)	—
③	Shaft	Stainless Steel(SUS304)	—

SH-60C, SH-80C

SH-100C

Item Code	Item Name	H	W	t	P <sub>1</sub>	P <sub>2</sub>	P <sub>3</sub>	P <sub>4</sub>	D <sub>1</sub>	D <sub>2</sub>	φ d	Weight
170-099-788	SH-60C	60	40	1.5	10	20	26	26	5	8.5	4.3	44g
170-099-787	SH-80C	80	50	2	15	25	26	38	5	9.5	5.3	86g
170-099-786	SH-100C	Refer to the above drawing										110g

## BUTT HINGE (W/SPRING)



## HG-BF3



HG-BF3-2L-SC

HG-BF3-2R-SO

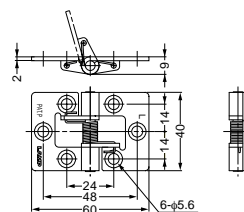

• Spring hinge to hold door.  
• Either closed or open available.

■ Closing Tension(SC type)

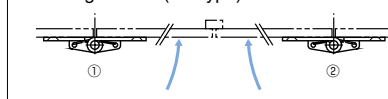

■ Opening Tension(SO type)

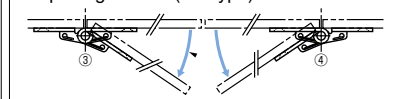

Item Code	Item Name	No.	Spec.	Material	Finish	Weight	Box	Carton
170-091-562	HG-BF3-2L-SC	①	Spec./Left	Stainless Steel (SUS304)	Polished	41g	20pcs	120pcs
170-091-564	HG-BF3-2R-SC	②	Spec./Right	Stainless Steel (SUS304)	Polished	41g	20pcs	120pcs
170-091-561	HG-BF3-2L-SO	③	Spec./Left	Stainless Steel (SUS304)	Polished	41g	20pcs	120pcs
170-091-563	HG-BF3-2R-SO	④	Spec./Right	Stainless Steel (SUS304)	Polished	41g	20pcs	120pcs

# DETENT HINGE



## HG-FH128



- Ideal for doors which need to be compressed.
- Horizontally adjustable for better compression.
- Holds doors at 60° and 120°.
- Max. Open: 152°.
- Plastic washer provides smooth movement.

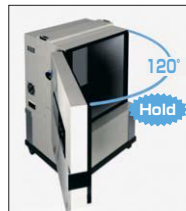
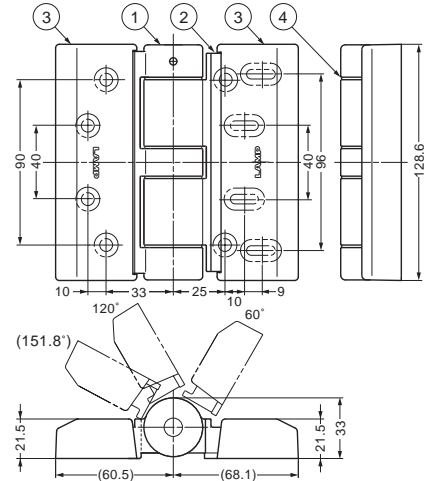
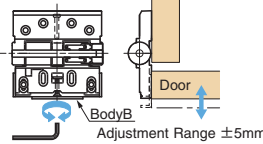
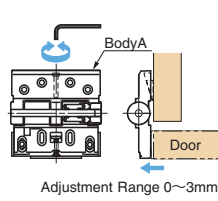
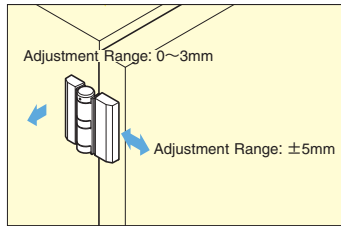

No.	Part Name	Material	Finish
①	BodyA	Zinc Alloy	Nickel
②	BodyB	Zinc Alloy	Nickel
③	CoverA, B	AES	Matte silver
④	Washer	Fluoroplastic	—

Item Code	Item Name	Door Width	Door Height	Door Weight	Retaining force(pc)	Weight	Box	Carton
170-090-317	HG-FH128	600-900	900-1200	Max.40kg	10N · m 102kgf · cm	1500g	1pcs	6pcs

# DETENT HINGE



## HG-YJ50

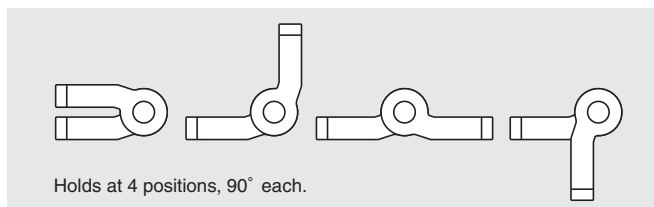

- Plastic hinge holds doors at 4 different positions (90° increment) without secondary support.
- Ivory or Black available.
- Door weight: Max.1.2kg/pair (2.6lbs/pair).

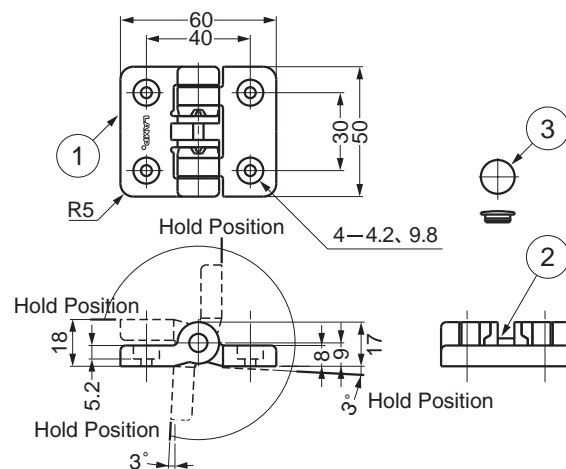

No.	Part Name	Material	Finish/Color
①	Body	Polyacetal	(IV : Ivory) (BL : Black)
②	Shaft	Stainless Steel (SUS303)	—
③	Cover	Polypropylene	(IV : Ivory) (BL : Black)

Item Code	Item Name	Color	Door Width	Door Height	Door Weight	Retaining force(pc)	Weight	Box
170-090-000	HG-YJ50 IV	Ivory	Max.400	Max.500	Max.1.2kg	49N · cm 5kgf · cm	30g	20pcs
170-090-002	HG-YJ50BL	Black	Max.400	Max.500	Max.1.2kg	49N · cm 5kgf · cm	30g	20pcs

# DETENT HINGE (WITH or WITHOUT DAMPER)



## HG-CSH63

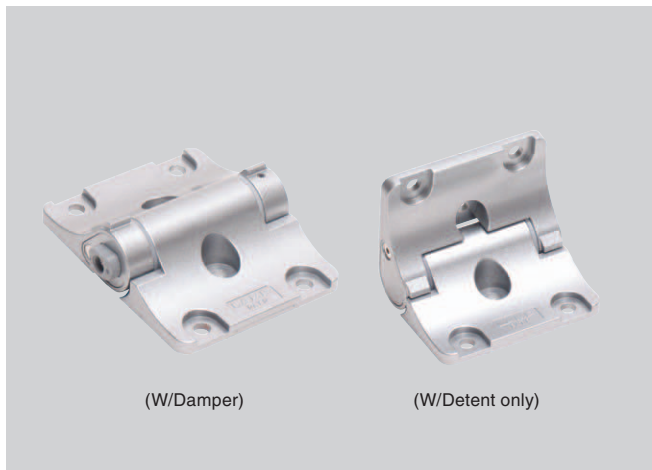

- Detent hinge with built-in damper as an option.
- Detent will hold lid in open/closed position without secondary support, and optional damper will provide soft closing.
- Operating angle: 100°.
- (Detent at both 0° and 100°).
- Detent holding force: 10.2 kgf-cm (8.8 lbs-in).
- Damper torque range: 10.2~25.5 kgf-cm (9~22 lbs-in)/pc.

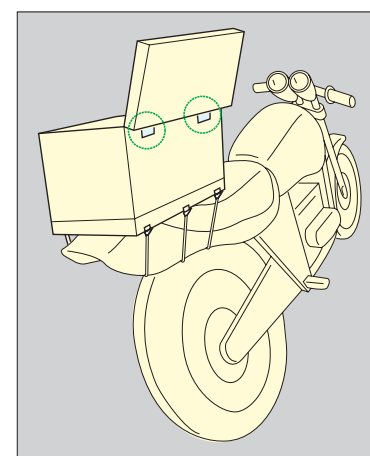
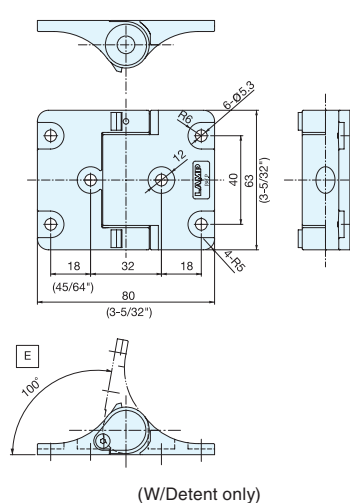
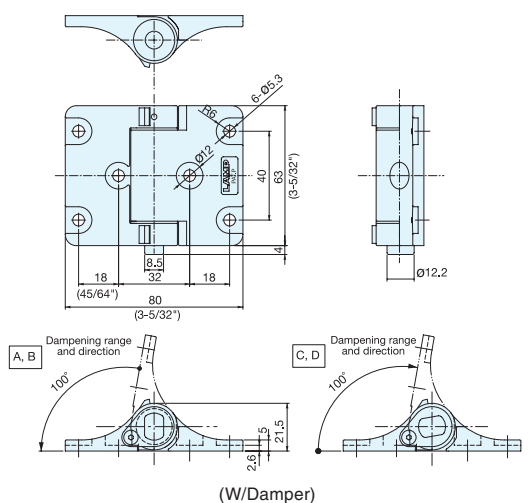

Item Code	Item Name	Torque (kgf-cm)/pc	Dampening Direction	Type	Weight	Box	Carton
170-090-108	HG-CSH63AH	17.3~25.5(15~22lbs-in)	Counter Clockwise	A	114.3g	10pcs	120pcs
170-090-109	HG-CSH63AM	10.2~17.3(9~15lbs-in)		B			
170-090-110	HG-CSH63BH	17.3~25.5(15~22lbs-in)	Clockwise	C	98.7g	10pcs	120pcs
170-090-111	HG-CSH63BM	10.2~17.3(9~15lbs-in)		D			
170-090-044	HG-CSH63	-	-	E	-	-	-

Material	Finish
Zinc Alloy	Silver

# DETENT HINGE



## HG-YC105

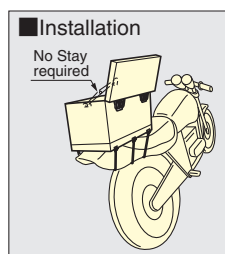

- Snaps in at 115° open position.
- Holds doors open without secondary support.

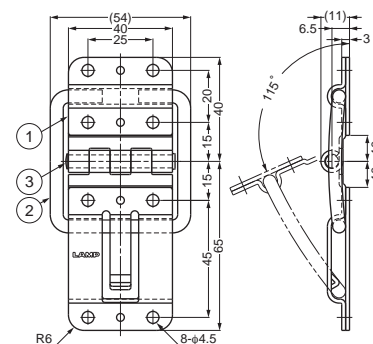

No.	Part Name	Material	Finish
①	Body	Stainless Steel (SUS304)	Mirror
②	Stopper	Stainless Steel (SUS304)	-
③	Shaft	Stainless Steel (SUS304)	-

Item Code	Item Name	Retaining force(pc)	Weight	Box
170-099-093	HG-YC105	118N·cm	122g	10pcs

# CONCEALED HINGE (W/STAY)



## HG-YS65C

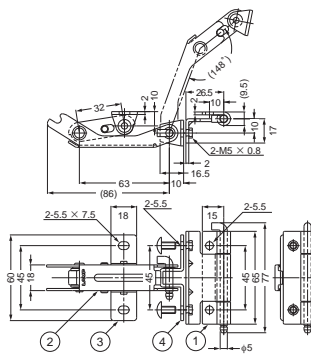

- Combination of hinge and stay.
- Designed for sheet metal applications.
- Stay holds door at 100° open position.
- Removable pin (included) allows for easy door installation/removal.
- Holding force: 30 kgf·cm/piece (26 lbs-in/piece)
- Door weight: Max. 10kg/pair (22 lbs/pair)
- Ring retainer for pins not included.

### Installation

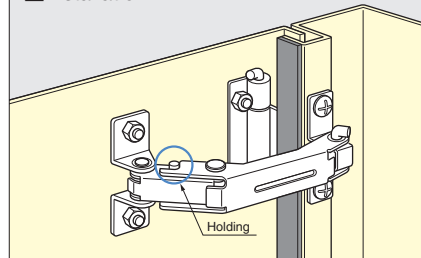

### Preparation

A	B	C
20	19	8.5
21	20	9.5
22	21	10.5
23	22	11.5
24	23	12.5
25	24	13.5

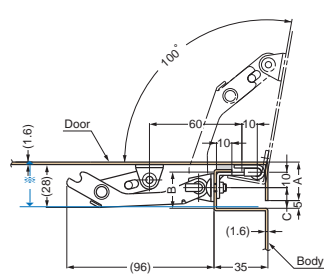

Item Code	Item Name	Weight	Box
170-100-087	HG-YS65C	190g	10pcs

No.	Part Name	Material	Finish
①	Hinge	Stainless Steel (SUS304)	Polished
②	Arm	Stainless Steel (SUS304)	Polished
③	Bracket	Stainless Steel (SUS304)	Polished
④	Hinge Bracket	Stainless Steel (SUS304)	Polished

# MULTI-ANGLE LOCKING STAY

## KA-60



- While the button is depressed, the lock is disengaged and it allows for the hinge angle to be adjusted from 10°-180° at 10° increments.
- When the button is released, the hinge locks in the desired angle.
- No pipe supplied.



### Installation

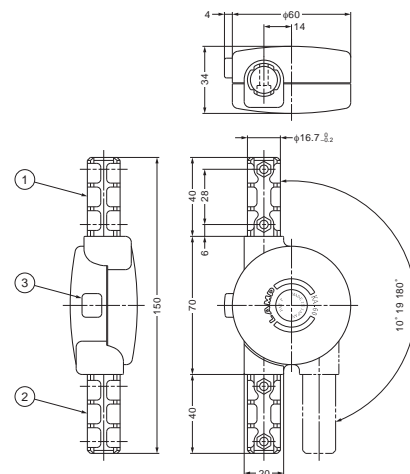
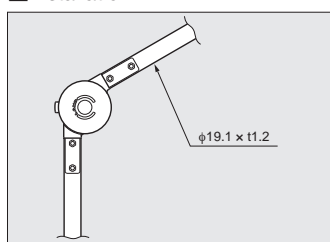

Item Code	Item Name	Applicable Pipe	Load Capacity	Weight	Box	Carton
170-890-570	KA-60	φ 19.1 × t1.2	25N·m 2.5kgf·m	170g	6pcs	60pcs

No.	Part Name	Material	Finish/Color
①	BodyA	Aluminum Alloy	Baked Lacquered/Ivory
②	BodyB	Aluminum Alloy	Baked Lacquered/Ivory
③	Release Button	Aluminum Alloy	Chrome

# HALF OVERLAY GLASS DOOR HINGE



## XL-GH03-48-8



- Half overlay Medium size hinge for glass/acrylic doors.
- Door thickness: 5~8 mm.
- Door size: Max. W650 x H900 x T8mm.
- Door weight: Max. 12kg/pair (26.4 lbs/pair).

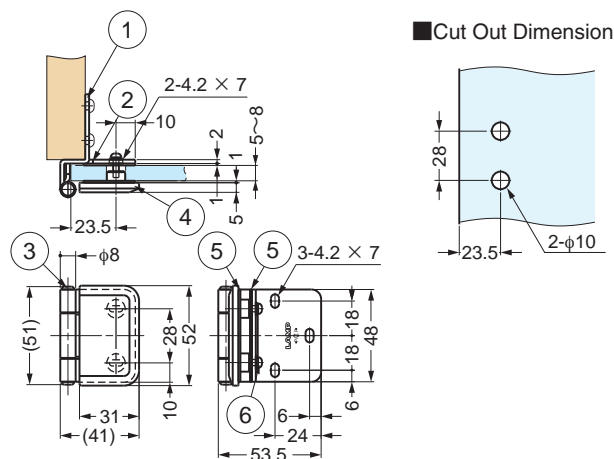

No.	Part Name	Material	Finish	
			CR	GC
①	Body	Stainless Steel (SUS304)	Mirror	Gold,Clear
②	Arm	Stainless Steel (SUS304)	Mirror	Gold,Clear
③	Shaft	Stainless Steel (SUS304)	Mirror	Plain,Gold,Clear
④	Plate	Zinc Alloy	Chrome	Gold,Clear
⑤	Washer	Polyethylene	Natural	Natural
⑥	Screw	Stainless Steel (SUS304)	Plain	Plain,Gold,Clear

Item Code	Item Name	Door Width	Door Height	Glass Thick	Door Weight	Box	Carton
170-098-649	XL-GH03-48-8CR	Max.650	Max.900	5,6,8	Max.12kg	10pcs	100pcs
170-098-650	XL-GH03-48-8GC	Max.650	Max.900	5,6,8	Max.12kg	10pcs	100pcs

# INSET GLASS DOOR HINGE



## XL-GH03-48-0



- Medium size hinge for glass/acrylic doors.
- Door thickness: 5~8 mm.
- Door size: Max. W650 x H900 x T8mm.
- Door weight: Max. 12kg/pair (26.4 lbs/pair).

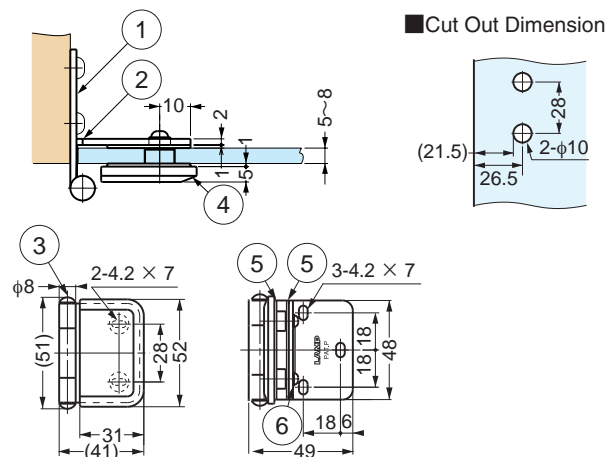

No.	Part Name	Material	Finish	
			CR	GC
①	Body	Stainless Steel (SUS304)	Mirror	Gold,Clear
②	Arm	Stainless Steel (SUS304)	Mirror	Gold,Clear
③	Shaft	Stainless Steel (SUS304)	Mirror	Plain,Gold,Clear
④	Plate	Zinc Alloy	Chrome	Gold,Clear
⑤	Washer	Polyethylene	Natural	Natural
⑥	Screw	Stainless Steel (SUS304)	Plain	Plain,Gold,Clear

Item Code	Item Name	Door Width	Door Height	Glass Thick	Door Weight	Box	Carton
170-098-651	XL-GH03-48-0CR	Max.650	Max.900	5,6,8	Max.12kg	10pcs	100pcs
170-098-652	XL-GH03-48-0GC	Max.650	Max.900	5,6,8	Max.12kg	10pcs	100pcs

## GLASS DOOR HINGE



## XL-GH01-600



- Pre-drilling on glass/acrylic not required.
- Door thickness: 4~8 mm.
- Door size: Max. W400 x H1300mm.
- Please use 2 spacers for 4mm door thickness.

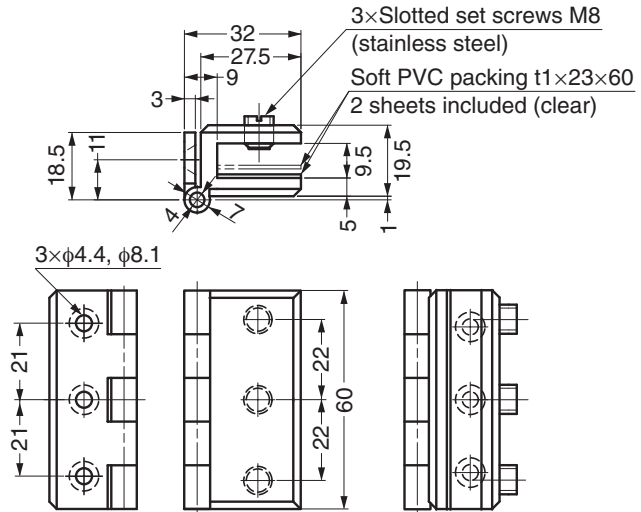

Material	Finish
304 Stainless Steel	Polished

Item Code	Item Name	Weight (g)	Box (pcs)	Carton (pcs)
170-080-501	XL-GH01-600	180	10	50

## GLASS DOOR HINGE



## XL-GH01-250



- Pre-drilling on glass/acrylic not required.
- Door thickness: 4~8 mm.
- Door size: Max. W400 x H600mm.
- Please use 2 spacers for 4mm door thickness.

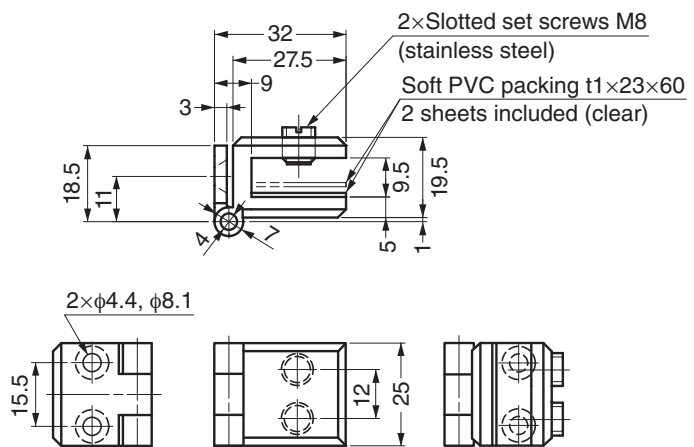

Material	Finish
304 Stainless Steel	Polished

Item Code	Item Name	Weight (g)	Box (pcs)	Carton (pcs)
170-080-500	XL-GH01-250	76	10	100



# INSET GLASS DOOR HINGE



# GH-34/0/S



- Hinge for glass/acrylic doors.
- Door thickness: 4-6 mm.
- Door weight: Max. 4kg/pair (8.8 lbs/pair).

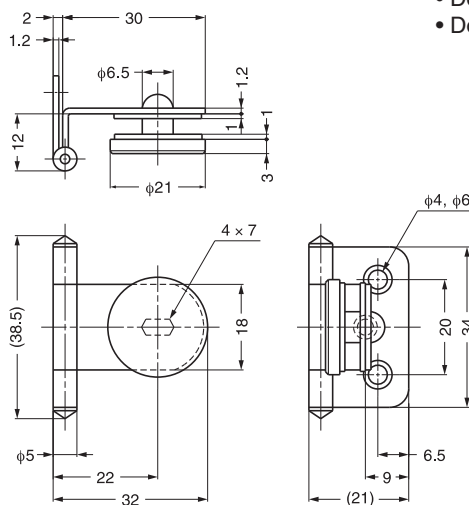

### Installation

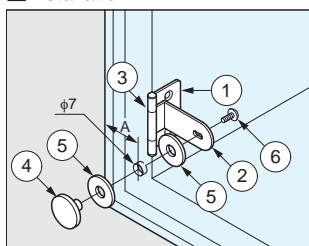

No.	Part Name	Material	Finish
①	Body	Stainless Steel (SUS304)	Plain
②	Arm	Stainless Steel (SUS304)	Plain
③	Shaft	Stainless Steel (SUS304)	Plain
④	Plate	Aluminum Alloy	Anodized
⑤	Washer	Chloroethylene	Clear
⑥	Screw	Stainless Steel (SUS304)	Plain

### Cut Out Dimensions

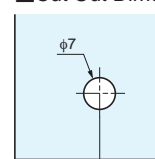

Glass Thick	A
4	19
5	18
6	17

Item Code	Item Name	Glass Thickness	Door Weight	Weight	Box	Carton
170-083-529	GH-34/0/S	4,5,6	Max.4kg	15g	150pcs	900pcs

# HALF OVERLAY GLASS DOOR HINGE



# GH-34/8/S



- Hinge for glass/acrylic doors.
- Door thickness: 4-6 mm.
- Door weight: Max. 4kg/pair (8.8 lbs/pair).

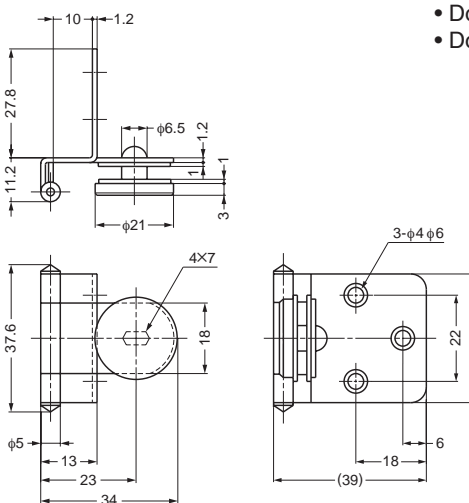

### Installation

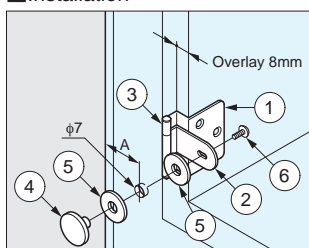

No.	Part Name	Material	Finish
①	Body	Stainless Steel (SUS304)	Plain
②	Arm	Stainless Steel (SUS304)	Plain
③	Shaft	Stainless Steel (SUS304)	Plain
④	Plate	Aluminum Alloy	Anodized
⑤	Washer	Chloroethylene	Clear
⑥	Screw	Stainless Steel (SUS304)	Plain

### Cut Out Dimensions

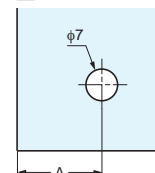

Glass Thick	A	Overlay
4	19	8
5	18	7
6	17	6

Item Code	Item Name	Door Width	Door Height	Door Weight	Glass Thick	Weight	Box	Carton
170-083-530	GH-34/8/S	Max.450	Max.700	Max.4kg	4,5,6	21g	100pcs	600pcs

# HALF OVERLAY GLASS DOOR HINGE



## GH-34/8

- Hinge for glass/acrylic doors.
- Door thickness: 4~6 mm.
- Door size: Max. W450 x H700 x t5mm.
- Door weight: Max. 4kg/pair (8.8 lbs/pair).

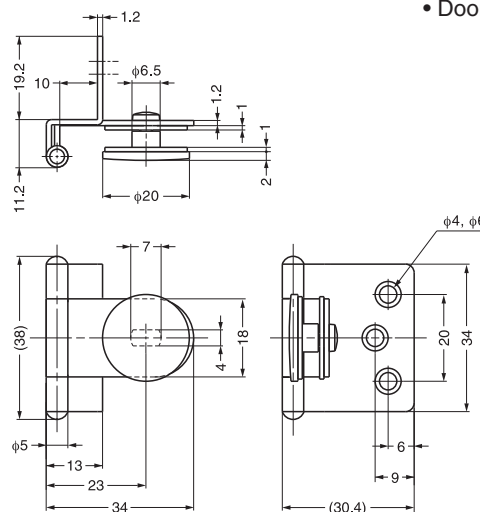

### Cut Out Dimensions

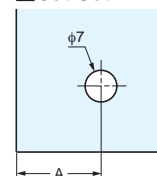

### Installation

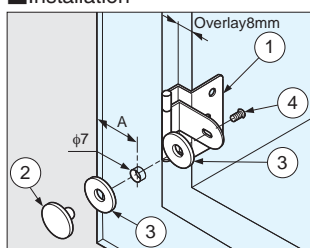

No.	Part Name	Material	Finish
①	Body	Steel	Chrome
②	Plate	Brass	Chrome
③	Washer	Chloroethylene	Clear
④	Screw	Steel	Nickel

Glass Thickness	A	Overlay
4	19	8
5	18	7
6	17	6

Item Code	Item Name	Door Width	Door Height	Glass Thickness	Door Weight	Weight	Box	Carton
170-083-528	GH-34/8/CR	Max.450	Max.700	4,5,6	Max.4kg	25g	50pcs	500pcs

# HALF OVERLAY GLASS DOOR HINGE (W/CATCH)



## GHC-34/8

- Hinge will hold door in closed position without secondary support.
- Door thickness: 4~6 mm.
- Door size: Max. W450 x H700 x t5mm.
- Door weight: Max. 4kg/pair (8.8 lbs/pair).

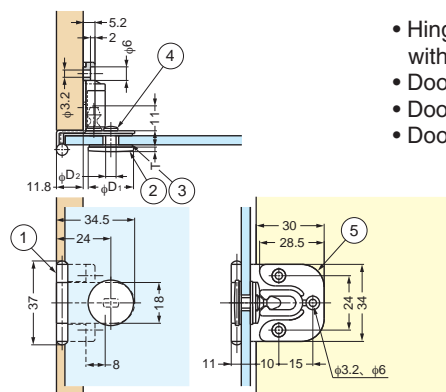

### Cut Out Dimensions

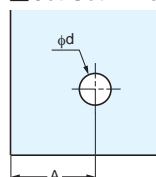

Glass Thickness	A	Overlay
4	19	7
5	18	6
6	17	5

No.	Part Name	Material	Finish/Color
①	Body	GHC-34/8/PB	Steel
①	Body	GHC-34/8/BLK	Stainless Steel (SUS304)
①	Body	GHC-34/8/CR	Steel
②	Plate	GHC-34/8/PB	Brass
②	Plate	GHC-34/8/BLK	Aluminum Alloy
②	Plate	GHC-34/8/CR	Brass
③	Washer	Chloroethylene	
④	Screw	GHC-34/8/CR, GHC-34/8/BLK/Steel	
④	Screw	GHC-34/8/PB/Brass	
⑤	Stopper	Polyacetal	
⑤	Stopper	Polyacetal	

Item Code	Item Name	D <sub>1</sub>	D <sub>2</sub>	d	T	Door Width	Door Height	Glass Thickness	Door Weight	Weight	Box	Carton
170-083-524	GHC-34/8/PB	20	6.5	7	2	Max.450	Max.700	4,5,6	Max.4kg	36g	40pcs	600pcs
170-083-508	GHC-34/8/BLK	21	8	8.5	3	Max.450	Max.700	4,5,6	Max.4kg	32g	40pcs	600pcs
170-083-523	GHC-34/8/CR	20	6.5	7	2	Max.450	Max.700	4,5,6	Max.4kg	36g	40pcs	600pcs
170-083-516	GHC-34/8/CR-W	20	6.5	7	2	Max.450	Max.700	4,5,6	Max.4kg	36g	40pcs	600pcs

# INSET GLASS DOOR LIFT-OFF HINGE



## GH-36/NCR



- Lift-off hinge for glass/acrylic doors.
- Door thickness: 4~6 mm
- Door size: Max. W450 x H700 x t5mm
- Door weight: Max. 4kg/pair (8.8 lbs/pair)

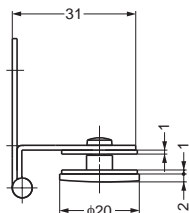

### Installation

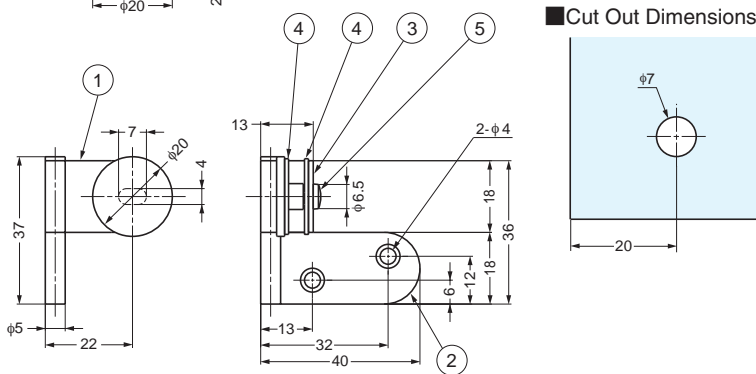
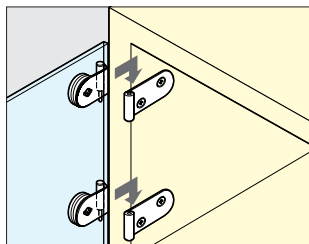

### Cut Out Dimensions

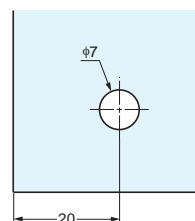

No.	Part Name	Material	Finish
①	Body(Strike)	Steel	Chrome
②	Body(Catch)	Steel	Chrome
③	Plate	Brass	Chrome
④	Washer	Chloroethylene	-
⑤	Screw	Steel	Nickel

Item Code	Item Name	Spec.	Door Width	Door Height	Glass Thickness	Door Weight	Weight	Box	Carton
170-097-958	GH-36/NCRR	Right	Max.450	Max.700	4, 5, 6	Max.4kg	24.5g	100pcs	400pcs
170-097-957	GH-36/NCRL	Left	Max.450	Max.700	4, 5, 6	Max.4kg	24.5g	100pcs	400pcs

# INSET GLASS DOOR HINGE



## GH-34/0



- Hinge for glass/acrylic doors.
- Door thickness: 4~6 mm
- Door size: Max. W450 x H700 x t5mm
- Door weight: Max. 4kg/pair (8.8 lbs/pair)

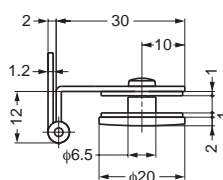

### Installation

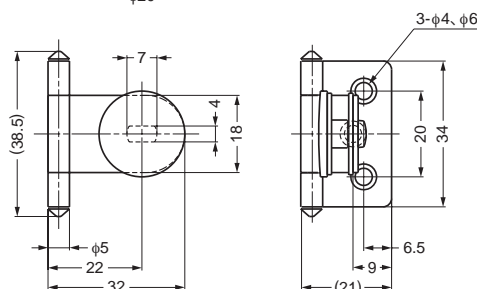
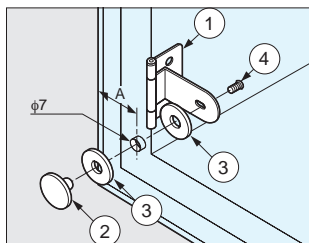

### Cut Out Dimensions

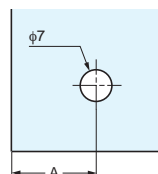

Glass Thickness	A
4	19
5	18
6	17

No.	Part Name	Material	Finish
①	Body	Steel	Chrome
②	Plate	Brass	Chrome
③	Washer	Chloroethylene	-
④	Screw	Steel	Nickel

Item Code	Item Name	Door Width	Door Height	Glass Thickness	Door Weight	Weight	Box	Carton
170-083-513	GH-34/0/CR	Max.450	Max.700	4, 5, 6	Max.4kg	23.5g	150pcs	900pcs

# HALF OVERLAY GLASS DOOR HINGE

# GH34-8CR-K

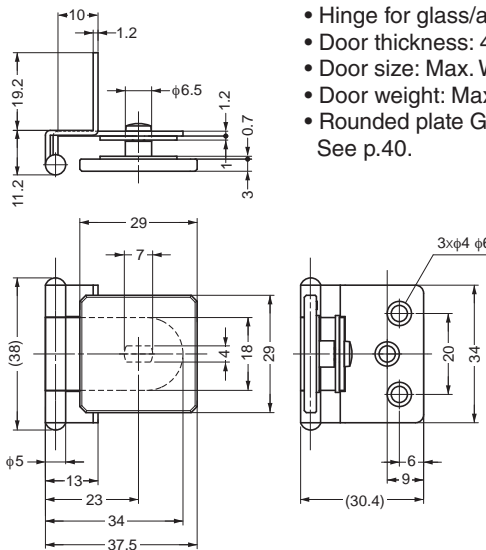

- Hinge for glass/acrylic doors.
- Door thickness: 4 ~ 5 mm.
- Door size: Max. W450 x H750 x t5mm.
- Door weight: Max.4kg/pair.
- Rounded plate GH34-8CR is available. See p.40.

### Installation

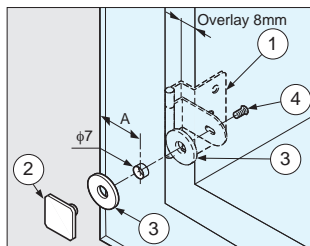

No.	Part Name	Material	Finish/Color
①	Body	Steel	Chrome
②	Plate	Zinc Alloy (ZDC)	Chrome
③	Washer	Polyvinyl Chloride (PVC)	Clear
④	Screw	Steel	Nickel

### Cut Out Dimensions

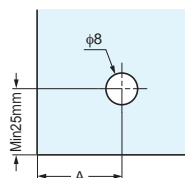

Glass Thickness	A	Overlay
4	19	8
5	18	7

Item Code	Item Name	Door Width	Door Height	Glass Thickness	Door Weight	Weight	Box	Carton
170-019-482	GH34-8CR-K	Max.450	Max.700	4,5	Max.4kg	37g	50pcs	500pcs

# HALF OVERLAY GLASS DOOR HINGE (W/CATCH)

# GHC34-8CR-K



- Hinge for glass/acrylic doors.
- Door thickness: 4 ~ 6 mm.
- Door size: Max. W450 x H750 x t5mm.
- Door weight: Max.4kg/pair.
- Rounded plate GHC34-8CR is available. See p.40.

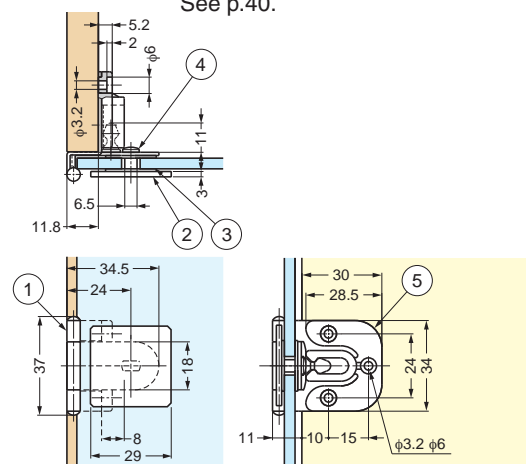

### Cut Out Dimensions

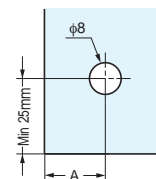

Glass Thickness	A	Overlay
4	19	7
5	18	6
6	17	5

No.	Part Name	Material	Finish/Color
①	Body	Steel	Chrome
②	Plate	Zinc Alloy (ZDC)	Chrome
③	Washer	Polyvinyl Chloride (PVC)	Clear
④	Screw	Steel	Nickel
⑤	Stopper	Polyacetal (POM)	Black

Item Code	Item Name	Door Width	Door Height	Glass Thickness	Door Weight	Weight	Box	Carton
170-019-480	GHC34-8CR-K	Max.450	Max.700	4,5,6	Max.4kg/2pcs	43g	40pcs	600pcs

# INSET GLASS DOOR HINGE

# GH34-0CR-K



- Hinge for glass/acrylic doors.
- Door thickness: 4 ~ 6 mm.
- Door size: Max. W450 x H750 x t5mm.
- Door weight: Max.4kg/pair.
- Rounded plate GH34-0CR is available. See p.41.

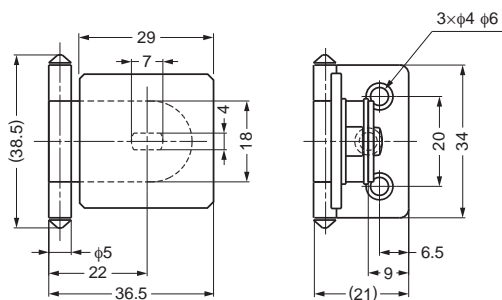
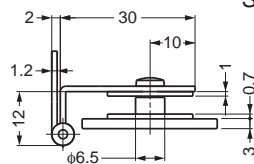

### Installation

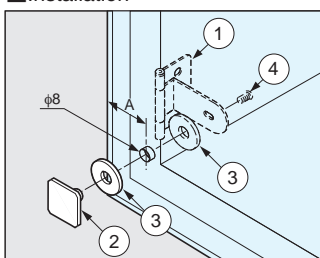

### Cut Out Dimensions

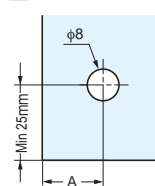

Glass Thickness	A
4	19
5	18
6	17

No.	Part Name	Material	Finish/Color
①	Body	Steel	Chrome
②	Plate	Zinc Alloy (ZDC)	Chrome
③	Washer	Polyvinyl Chloride (PVC)	Clear
④	Screw	Steel	Nickel

Item Code	Item Name	Door Width	Door Height	Glass Thickness	Door Weight	Weight	Box	Carton
170-019-481	GH34-0CR-K	Max.450	Max.700	4,5,6	Max.4kg/2pcs	34g	150pcs	900pcs

# OVERLAY DOOR PIVOT HINGE



# PL-65



- Door Size: Max. W450 x H700 x t21mm. (W17-23/32" x H27-9/16" x t53/64").
- Door weight: Max. 2.6kg/pair (5.7lbs/pair).

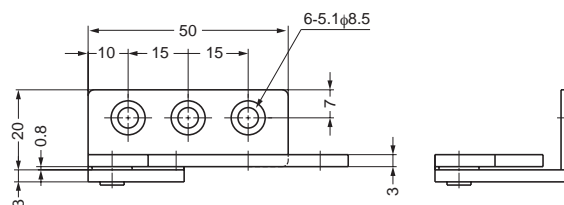
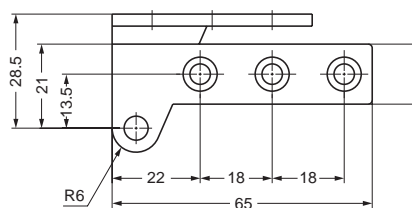
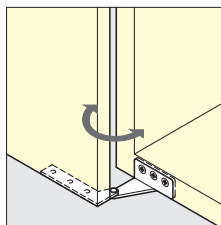

Item Code	Item Name	Spec.	Material	Finish	Door Width	Door Height	Door Thickness	Door Weight	Weight	Box	Carton
170-099-190	PL65R	Right	Stainless Steel (SUS430)	Plain	Max.450	Max.700	22	Max.4kg	55g	40pcs	400pcs
170-099-191	PL65L	Left	Stainless Steel (SUS430)	Plain	Max.450	Max.700	22	Max.4kg	55g	40pcs	400pcs

# OVERLAY DOOR PIVOT HINGE



WP

- Door Size: Max. W300 x H700mm.
- Door weight: Max. 1.8kg/pair.

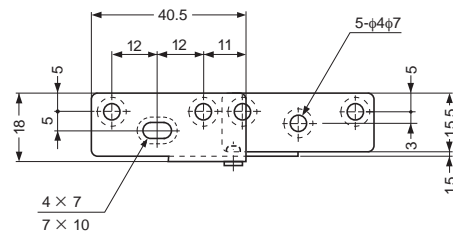
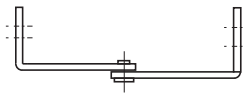
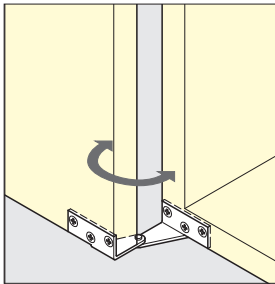
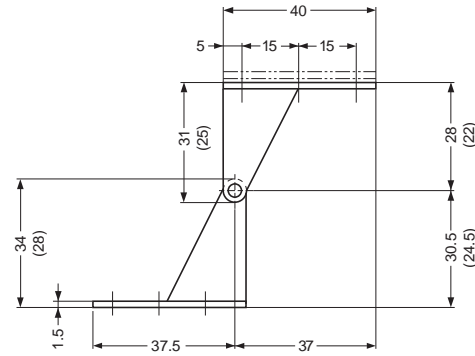
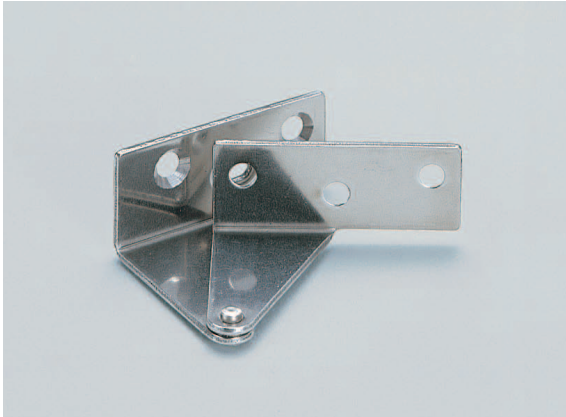

Item Code	Item Name	Spec.	Material	Finish	Door Width	Door Height	Door Thickness	Door Weight	Weight	Box
170-090-257	WP1R	Right	Stainless Steel (SUS430)	Plain	Max.300	Max.700	Max.24	Max.1.8kg	23g	100pcs
170-090-258	WP1L	Left	Stainless Steel (SUS430)	Plain	Max.300	Max.700	Max.24	Max.1.8kg	23g	100pcs
170-090-259	WP3R	Right	Stainless Steel (SUS430)	Plain	Max.300	Max.700	Max.18	Max.1.8kg	21g	100pcs
170-090-260	WP3L	Left	Stainless Steel (SUS430)	Plain	Max.300	Max.700	Max.18	Max.1.8kg	21g	100pcs

# OVERLAY DOOR PIVOT HINGE



PL-60

- Door Size: Max. W450 x H700mm.
- Door weight: Max. 2.6kg/pair.

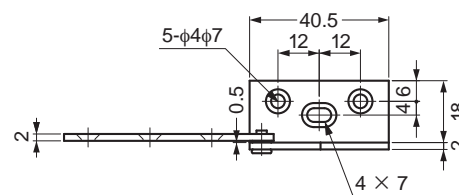
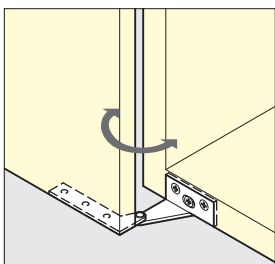
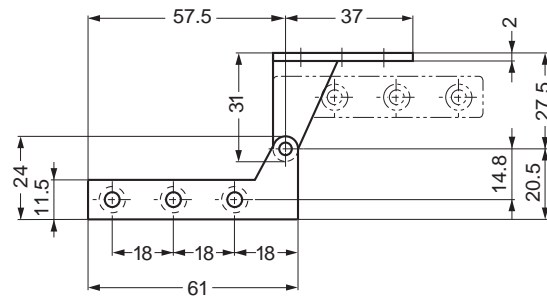
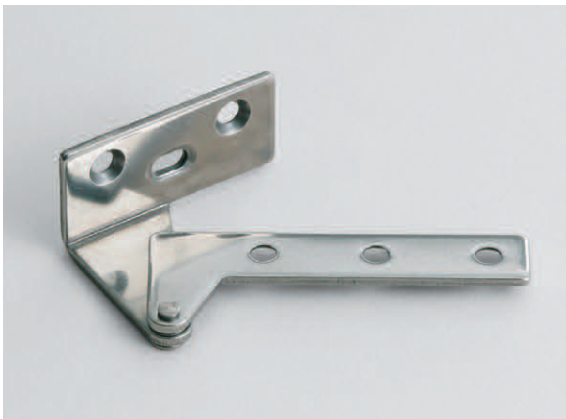

Item Code	Item Name	Spec.	Material	Finish	Door Width	Door Height	Door Thickness	Door Weight	Weight	Box
170-090-263	PL-60R	Right	Stainless Steel (SUS430)	Plain	Max.450	Max.700	22	Max.2.6kg	27g	100pcs
170-090-264	PL-60L	Left	Stainless Steel (SUS430)	Plain	Max.450	Max.700	22	Max.2.6kg	27g	100pcs

## INSET DOOR PIVOT HINGE



## PP-60

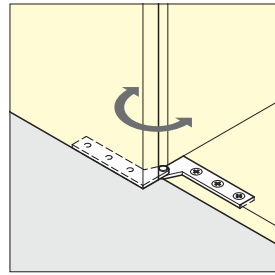

- Door Size: Max. W450 x H700 x t21mm.
- Door weight: Max. 2.6kg/pair.

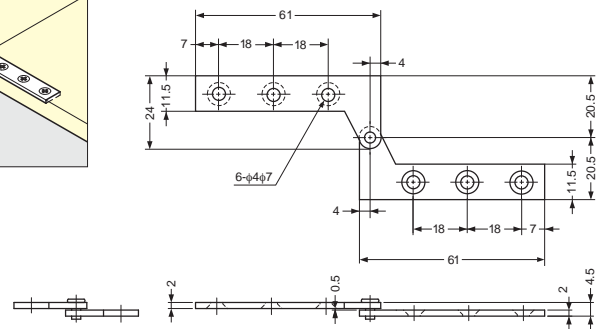

Item Code	Item Name	Spec.	Material	Finish	Door Width	Door Height	Door Weight	Weight	Box
170-090-261	PP-60R	Right	Stainless Steel (SUS430)	Plain	Max.450	Max.700	Max.2.6kg	22g	100pcs
170-090-262	PP-60L	Left	Stainless Steel (SUS430)	Plain	Max.450	Max.700	Max.2.6kg	22g	100pcs

## OVERLAY DOOR PIVOT HINGE



## PL-100

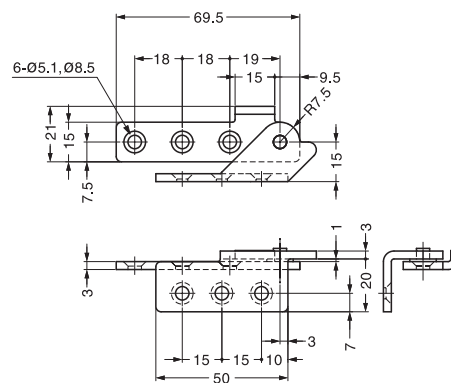

- Door Size: Max. W600 x H750mm.
- Door Weight: Max.6kg/pair.

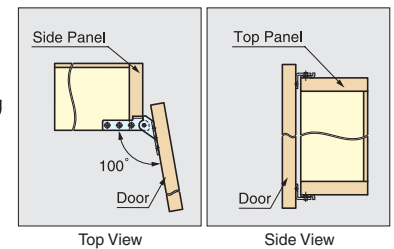

Item Code	Item Name	Weight	Finish	Box	Carton
170-099-380	PL-100L	55	Plain	100pcs	1000pcs
170-099-379	PL-100R	55	Plain	100pcs	1000pcs

Material	Finish
430 Stainless Steel	Plain

## Installation example for metal sheet applications

Concealed hinges can be used in metal sheet applications.

### Bracket Construction

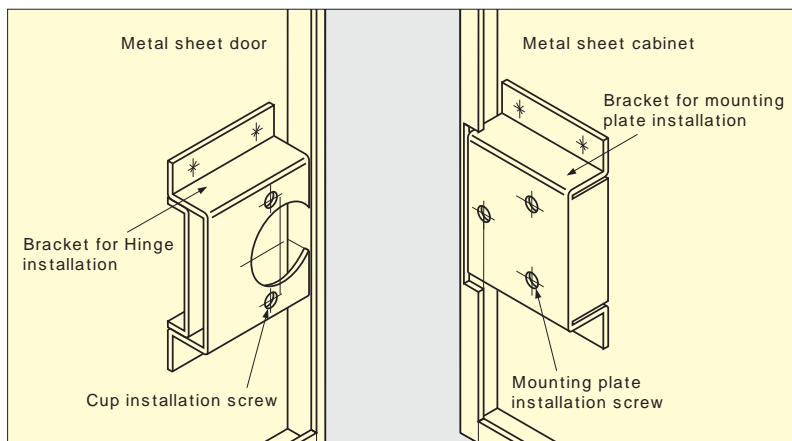

### Installation



# CONCEALED HINGE (CLIP-ON)



HT-160

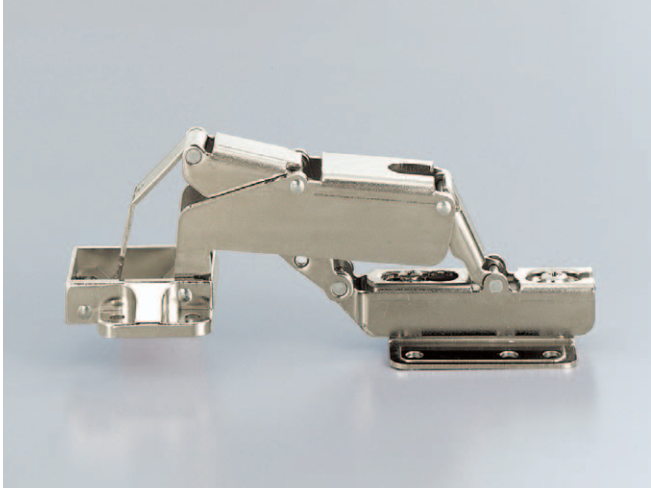

- 95° opening concealed hinge.
- Door opens without interfering side cabinets.
- Ideal when 2 doors are close together.
- The mounting plate is attached to the hinge body.

Item Code	Item Name	Part Name	Finish	Weight (g)	Carton
160-070-328	HT-160	Cup/Zinc Alloy Body/Steel	Nickel	252	100pcs

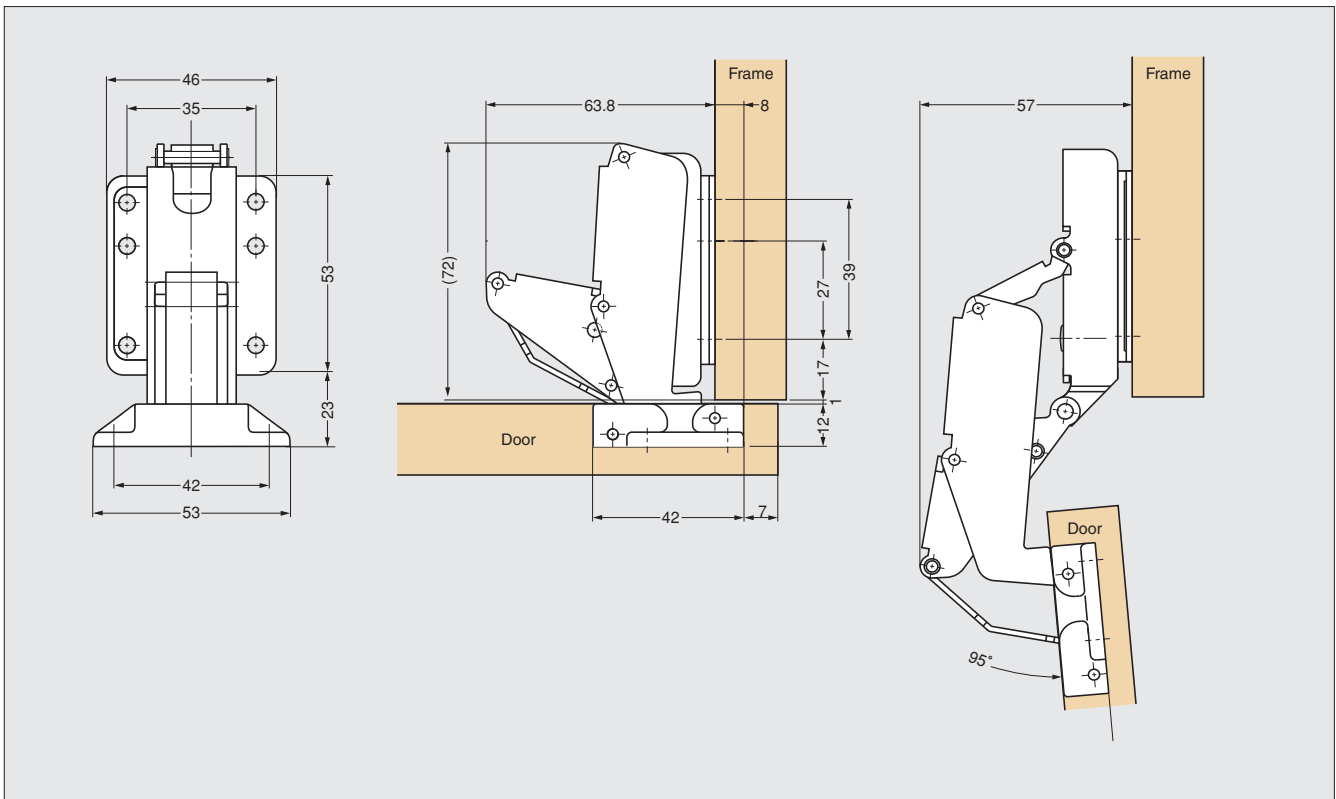

HT-160THV2

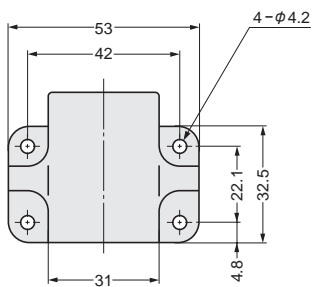

HT-160TZ(Mounting Plate)

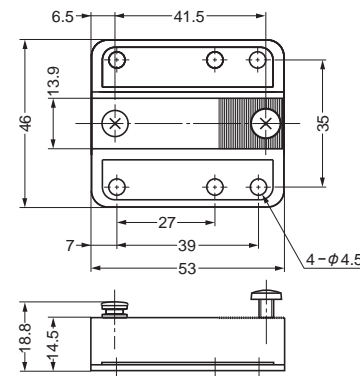

Material	Finish
Steel	Nickel



# CONCEALED HINGE (SNAP-ON)



## HT-160THV2

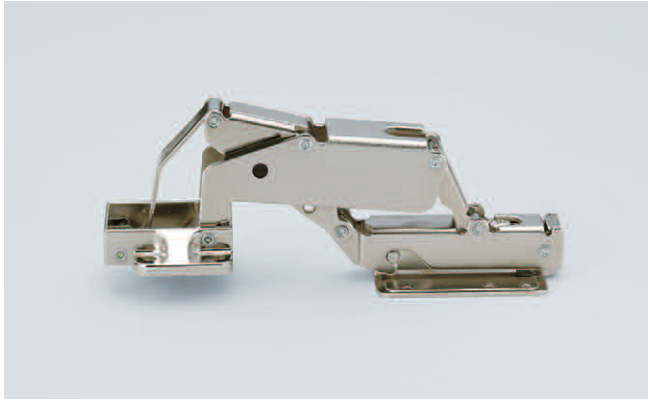

- 95° opening concealed hinge.
- Door opens without interfering side cabinets.
- Ideal when 2 doors are close together.
- Snap-on feature allows easy door installation/removal.
- Ordering instructions:  
-Clip on:order HT-160THV2 & HT-160TZ for complete set.

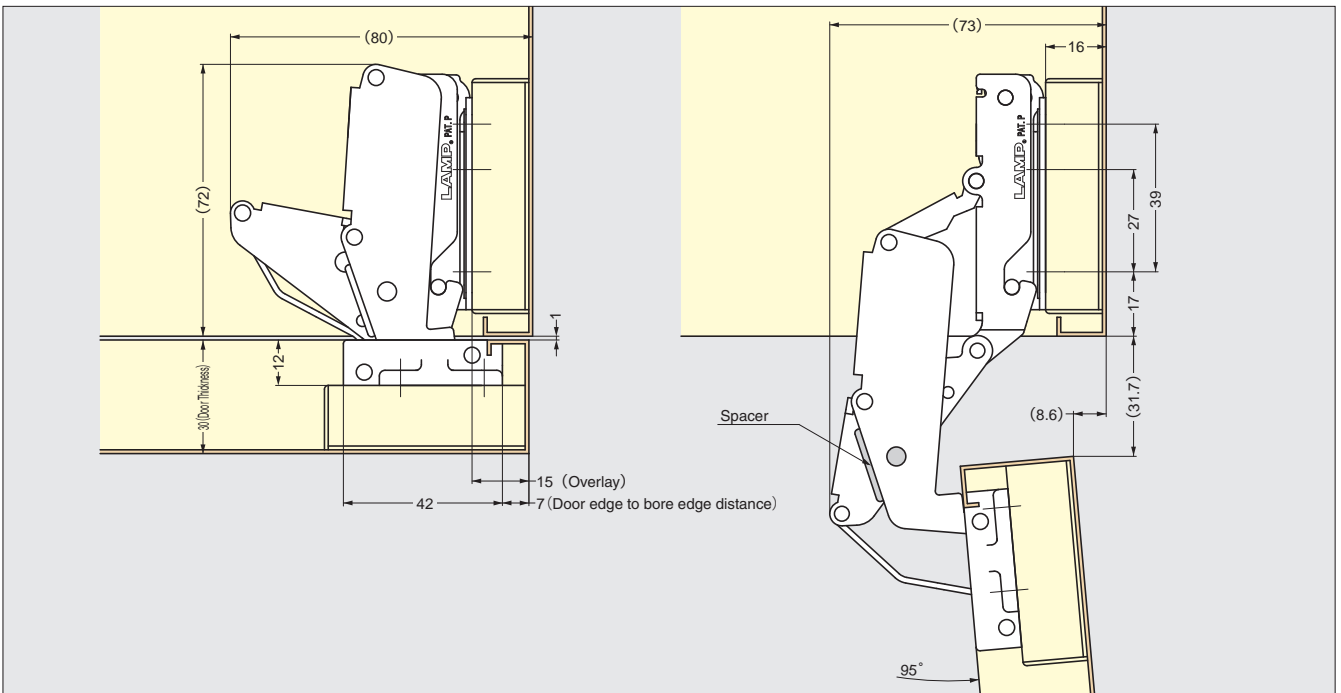

### Installation

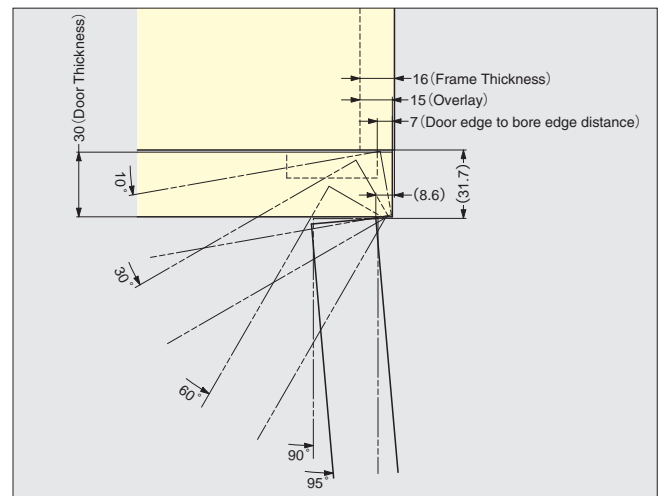
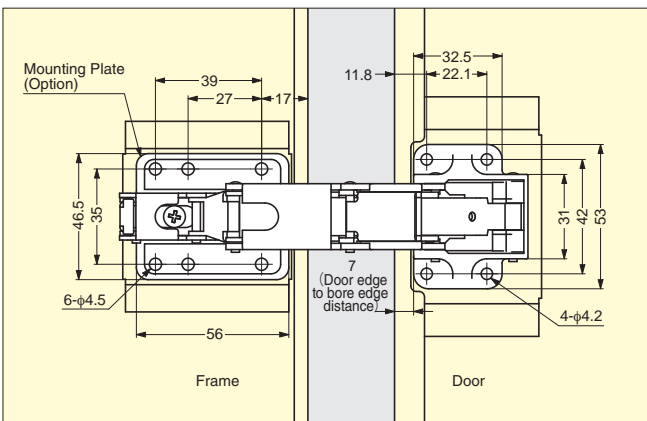

Item Code	Item Name	Part Name	Material	Finish	Weight	Carton
160-070-327	HT160THV2-G	Body (with Plate & Spacer)	Zinc Alloy (Cup) / Steel (Body) / Polyacetal (Spacer)	Nickel (Cup, Body) / Black (Spacer)	205g	100pcs
160-070-391	HT160TZ	Mounting Plate	Steel	Nickel	68g	200pcs

# CONCEALED HINGE (CLIP-ON)



H95TM

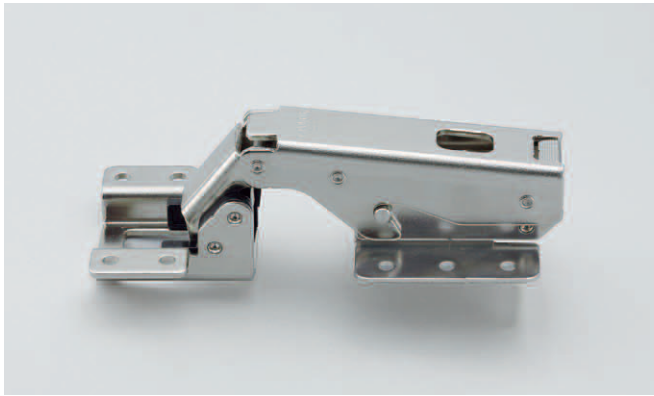

- 95° opening concealed hinge.
- Clip-on feature allows easy door installation/removal.
- Door opens without interfering side cabinets.
- Ideal when 2 doors are close together.

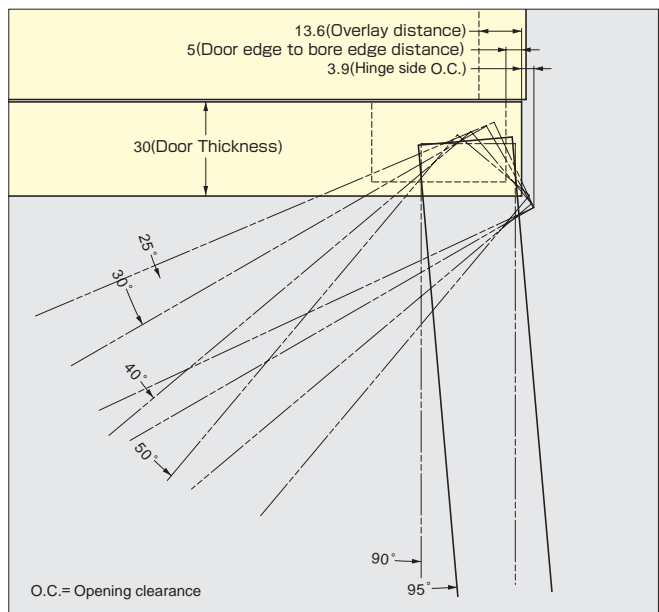
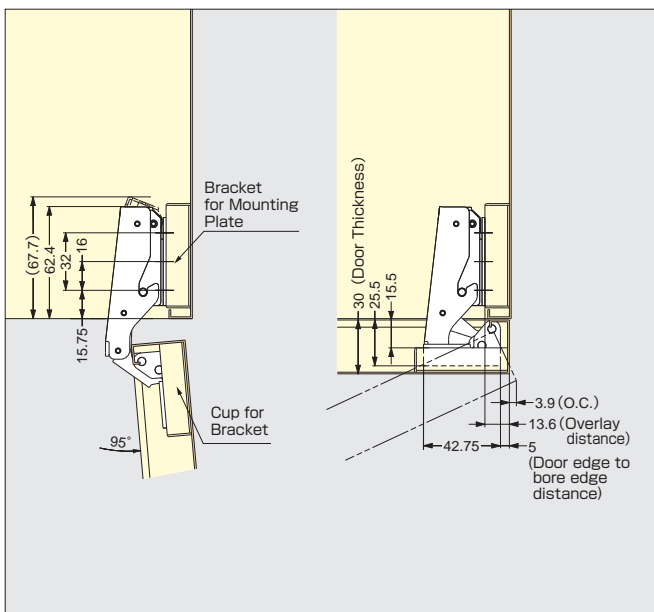

■ Installation

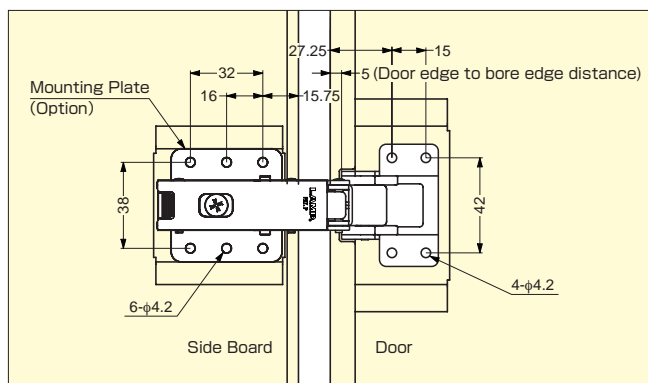

■ Body

Item Code	Item Name	Material	Finish	Carton
160-070-101	H95TMH	Steel	Nickel	100pcs

■ Mounting Plate

Item Code	Item Name	Material	Finish	Carton
160-070-102	H95TMZ	Steel	Nickel	100pcs

# CONCEALED HINGE (CLIP-ON)



## H95TS

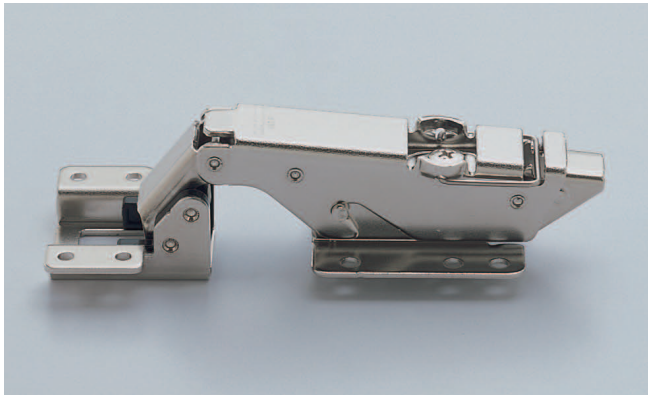

- 95° opening concealed hinge.
- Clip-on feature allows easy door installation/removal.
- Safety lock feature.
- Door opens without interfering side cabinets.
- Ideal when 2 doors are close together.

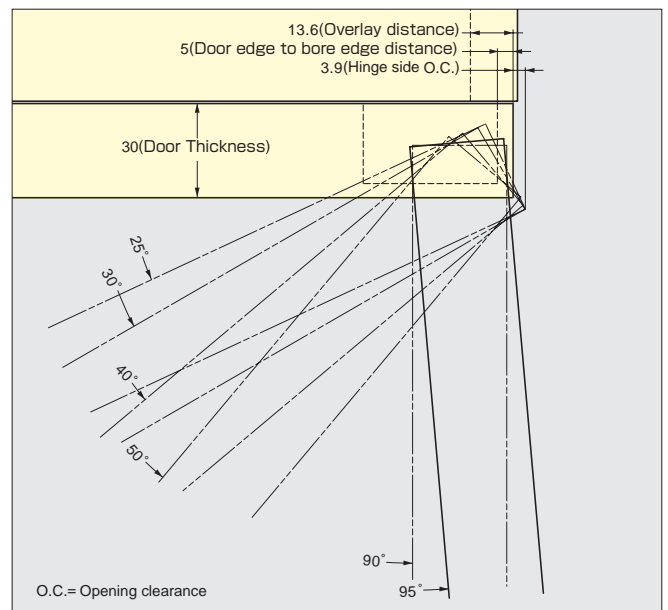
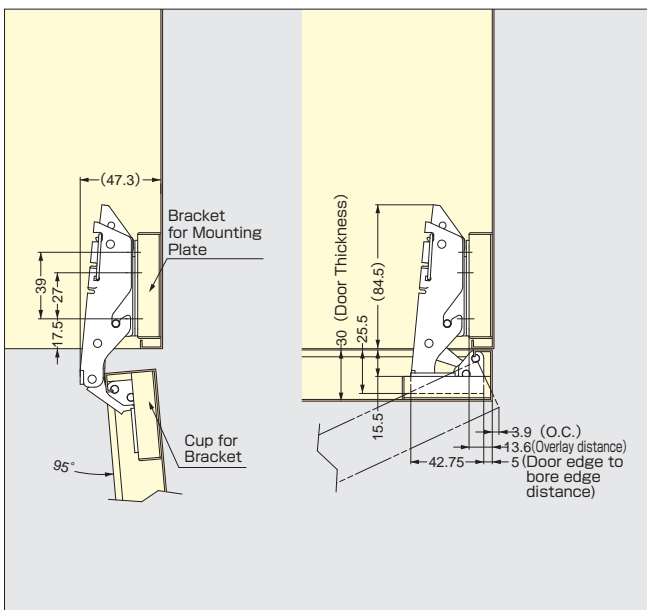

### Installation

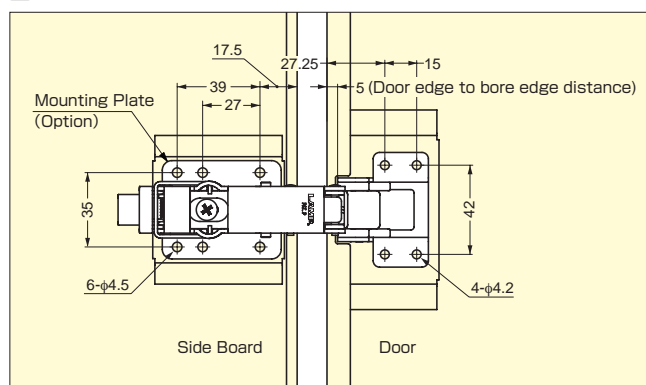

### Body

Item Code	Item Name	Material	Finish	Carton
160-073-590	H95TSH	Steel	Nickel	100pcs

### Mounting Plate

Item Code	Item Name	Material	Finish	Carton
160-073-591	H95TSZ	Steel	Nickel	100pcs

# CONCEALED HINGE (19mm OVERLAY)



100-46/19, C46/19 SUS 304B

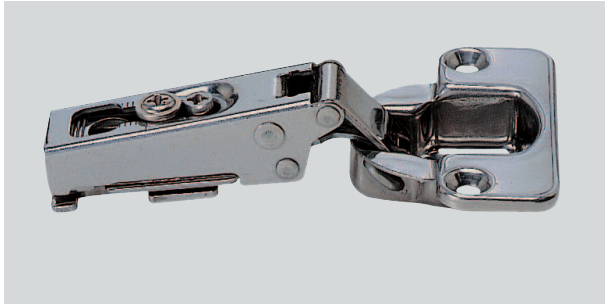

Door edge to bore edge distance (C) and Overlay distance (B) Table 1.

Door edge to bore edge distance (C)	3	4	5
Overlay distance (B)	17	18	19

Hinge side opening clearance chart Table 2.

Door thickness (D)	Door edge to bore edge distance (C)		
	3	4	5
15	0.5	0.5	0.5
16	0.7	0.7	0.7
17	0.8	0.8	0.8
18	1.0	1.0	1.0
19	1.2	1.2	1.2
20	1.4	1.4	1.4
Hinge side O.C. (A)			

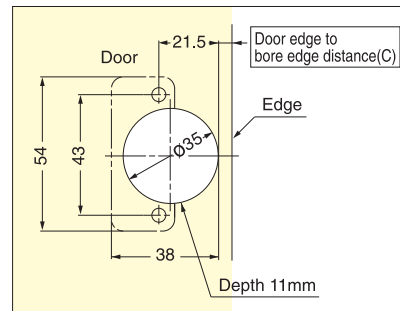
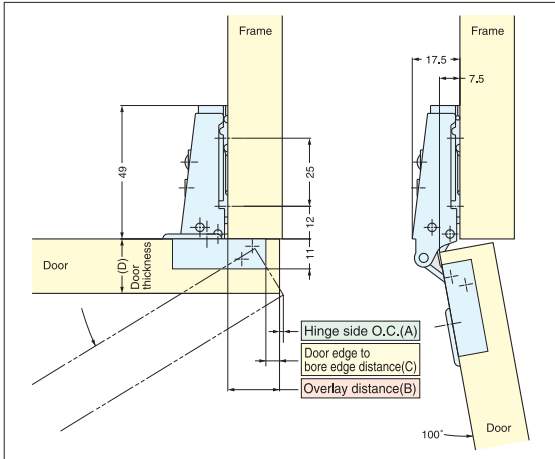

Bore Dimensions

Item Code	Item Name	Type	Weight	Carton
160-073-865	100-46/19 SUS 304B	Free Swinging	60g	200pcs
160-073-870	100-C46/19 SUS 304B	Self-Closing		

Material	Finish
304 Stainless Steel	Polished

# CONCEALED HINGE (14mm OVERLAY)



100-46/14, C46/14 SUS 304B

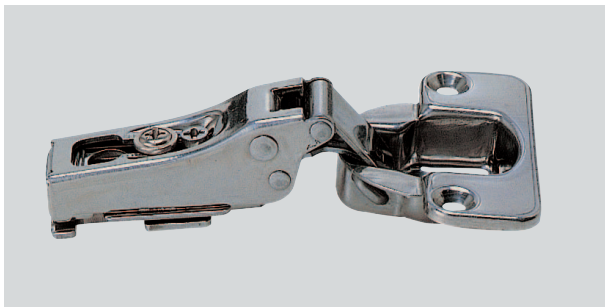

Door edge to bore edge distance (C) and Overlay distance (B) Table 1.

Door edge to bore edge distance (C)	3	4	5
Overlay distance (B)	12	13	14

Hinge side opening clearance chart Table 2.

Door thickness (D)	Door edge to bore edge distance (C)		
	3	4	5
15	0.5	0.5	0.5
16	0.7	0.7	0.7
17	0.8	0.8	0.8
18	1.0	1.0	1.0
19	1.2	1.2	1.2
20	1.4	1.4	1.4
Hinge side O.C. (A)			

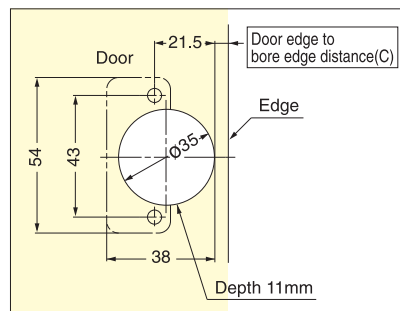
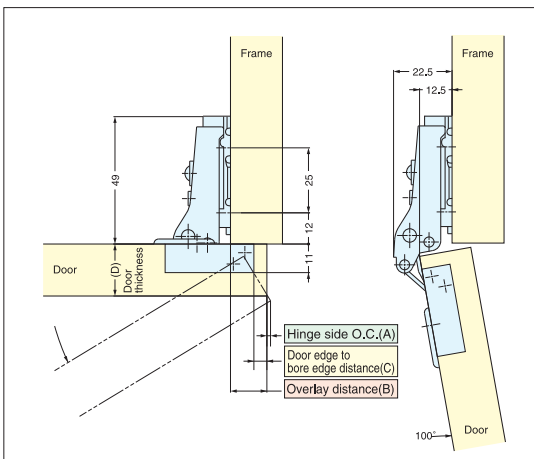

Bore Dimensions

Item Code	Item Name	Type	Weight	Carton
160-073-875	100-46/14 SUS 304B	Free Swinging	60g	200pcs
160-073-880	100-C46/14 SUS 304B	Self-Closing		

Material	Finish
304 Stainless Steel	Polished

# CONCEALED HINGE (9mm OVERLAY)



100-46/9, C46/9 SUS 304B

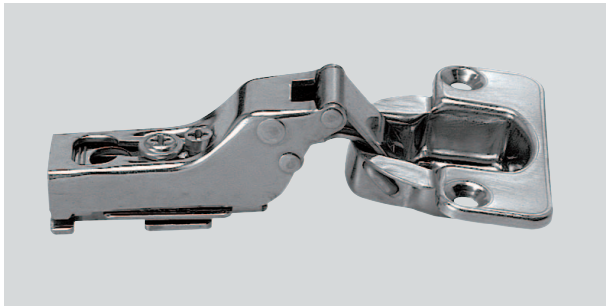

Door edge to bore edge distance (C) and Overlay distance (B) Table 1.

Door edge to bore edge distance (C)	3	4	5
Overlay distance (B)	7	8	9

Hinge side opening clearance chart Table 2.

Door thickness (D)	Door edge to bore edge distance (C)		
	3	4	5
15	0.5	0.5	0.5
16	0.7	0.7	0.7
17	0.8	0.8	0.8
18	1.0	1.0	1.0
19	1.2	1.2	1.2
20	1.4	1.4	1.4

Hinge side O.C. (A)

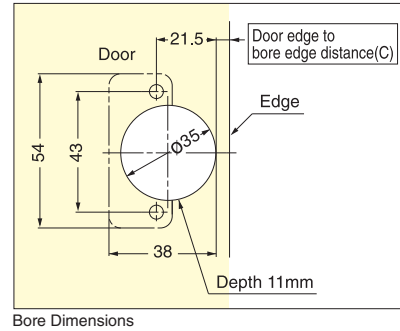
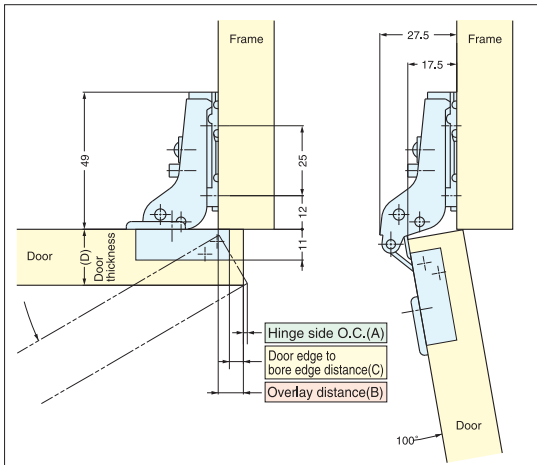

Item Code	Item Name	Type	Weight	Carton
160-073-883	100-46/9 SUS 304B	Free Swinging	60g	200pcs
160-073-884	100-C46/9 SUS 304B	Self-Closing		

Material	Finish
304 Stainless Steel	Polished

# MOUNTING PLATE



100-P3A, P4A/32, P4A/32-3W SUS 304B

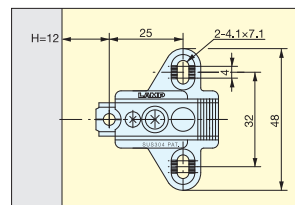
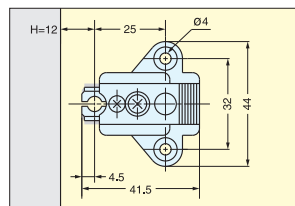
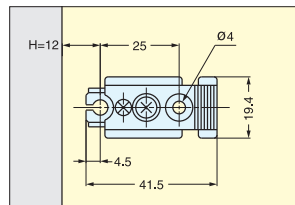
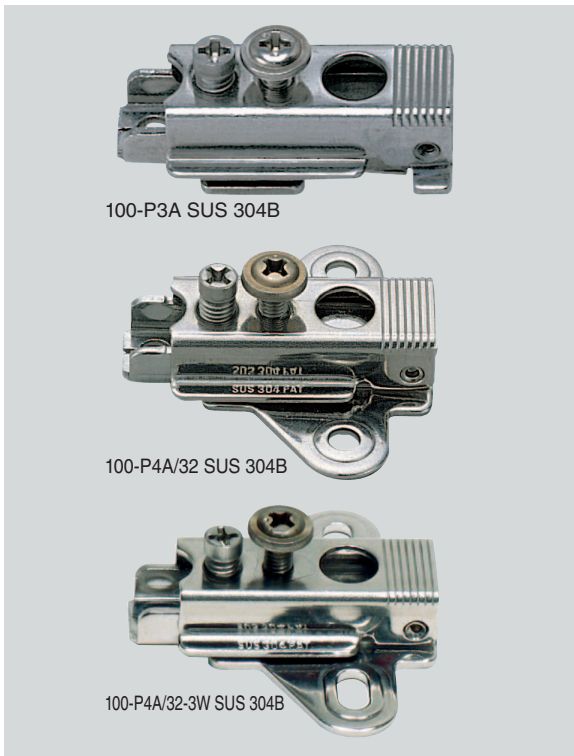

Installation

- Mounting plate for 100 hinges.

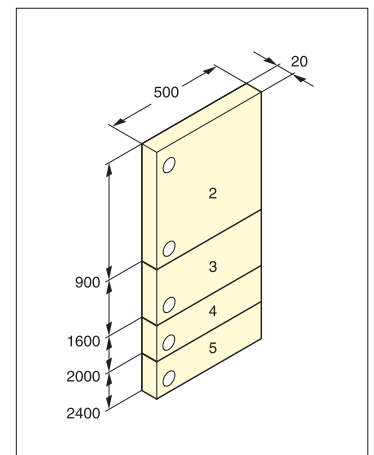

Number of hinges required.

Item Code	Item Name	Weight	Carton
160-074-155	100-P3A SUS 304B	40g	400pcs
160-079-056	100-P4A/32 SUS 304B		
160-079-044	100-P4A/32-3W SUS 304B		

Material	Finish
304 Stainless Steel	Polished

# CONCEALED HINGE



# R SERIES

• Door size: Max. W450×H700×t 21mm.

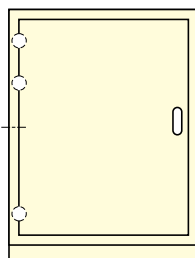
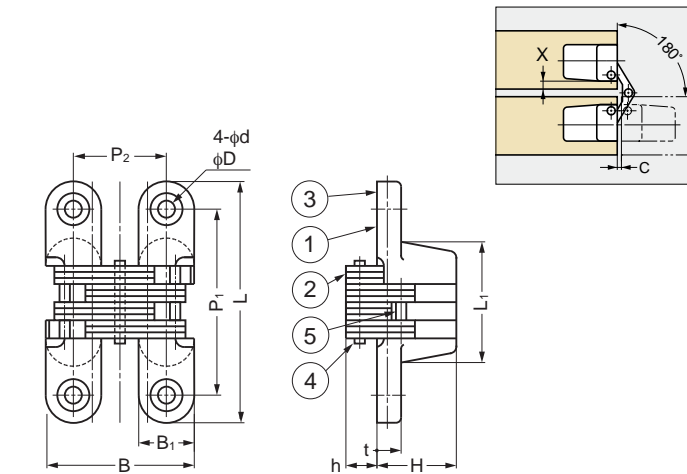
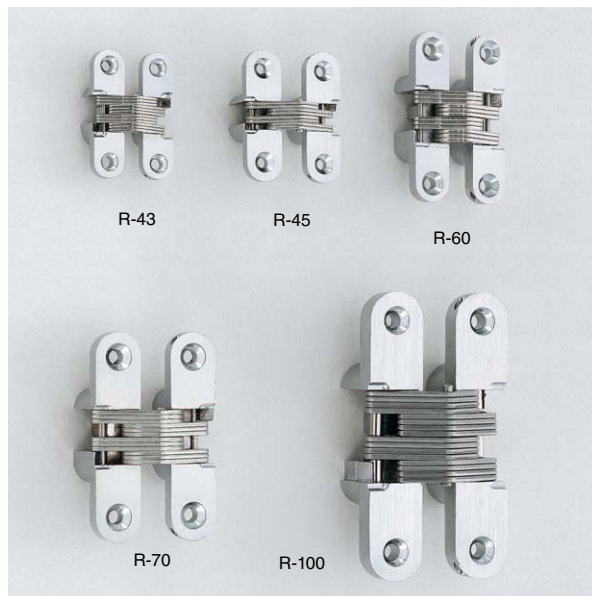

Installation position in case of 3 hinges

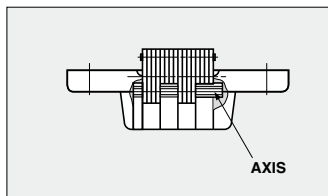

### For Sheet Metal Application

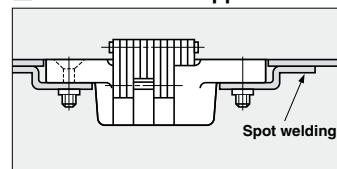

No.	Part Name	Material	Finish
①	Body	Zinc Alloy	Satin Chrome
②	Arm	Stainless Steel (SUS304)	Plain
③	Shaft	R-43/R-45/R-60/R-70: Stainless (SUS304), R-100: Steel	Plain
④	Shaft	R-43/R-45/R-60/R-100: Stainless Steel, R-70: Stainless (SUS304)	Plain
⑤	Shaft	R-43/R-45/R-60/R-70: Stainless (SUS304), R-100: Steel	Plain
※	Roller	Steel: R-100 Only	Nickel

Item Code	Item Name	L	L <sub>1</sub>	B	B <sub>1</sub>	P <sub>1</sub>	P <sub>2</sub>	H	h	t	D	d	C	X	Arm (qty)	Door Width	Door Height	Door Weight	Opening Angle	Weight	Box	Carton
170-090-079	R-43	43	22	29	11	32	18	13	(5)	5	6.2	3.5	0.8	2.3	12	Max. 450	Max. 700	Max. 2.6kg	180°	37g	30pcs	300pcs
170-090-084	R-45	45	19	35.7	13	32	22.7	18.5	(6)	5	7	3.5	0.8	3	8	Max. 450	Max. 700	Max. 2.6kg	180°	56g	20pcs	200pcs
170-090-081	R-60	60	33	35.2	13	47	22.2	18.5	(6.5)	6.5	8.3	4.3	1	3	12	Max. 450	Max. 700	Max. 2.6kg	180°	94g	10pcs	100pcs
170-095-200	R-70	70	35	42.6	16.1	53	26.6	23	(7.3)	7	9.1	4.6	1.2	3.5	12	Max. 450	Max. 700	Max. 4kg	180°	157g	10pcs	100pcs
170-095-201	R-100	100	52	53.2	20	80	33.2	27.5	(9.5)	9.5	10	5.3	1.8	4.8	16	Max. 450	Max. 700	Max. 4kg	180°	342g	10pcs	60pcs

# CONCEALED HINGE



# RK-50

• Door size: Max. W450×H700×t 21 mm.  
• Door weight: Max. 2.6 kg/pair.

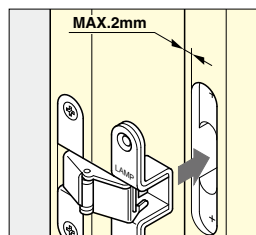
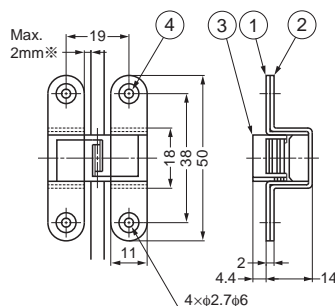

Installation

No.	Part Name	Material	Finish
①	Body	Stainless Steel (SUS304)	Satin
②	Case	Stainless Steel (SUS304)	—
③	Arm	Stainless Steel (SUS304)	Satin
④	Fastener	Stainless Steel (SUS304)	—

Item Code	Item Name	Door Width	Door Height	Door Thickness	Door Weight	Opening Angle	Weight	Box	Carton
170-090-086	RK-50	Max. 450	Max. 700	Min. 15	Max. 2.6kg	180°	28g	24pcs	240pcs

# CONCEALED HINGE



I-66



### Installation

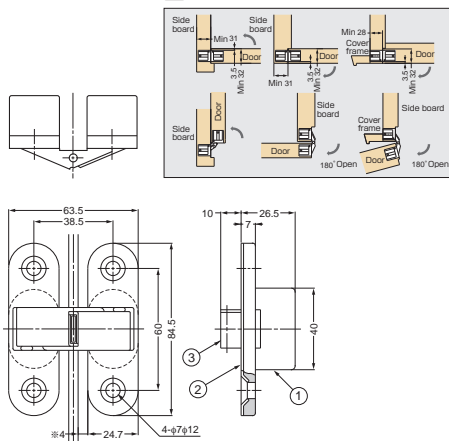

- Door weight:  
I-66 Max. 30kg/pair.  
Max. 50kg/3pcs.

### Bore Dimensions

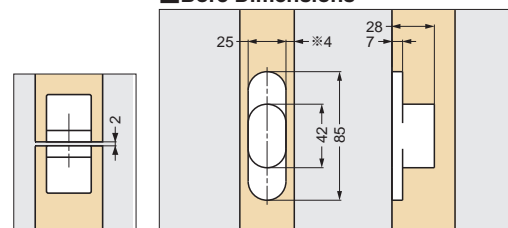

Distance between door edge and hinge must be less than 4mm.

No.	Part Name	Material	Finish
①	Body	Polyamide	White
②	FrontPlate	Stainless Steel (SUS304)	Satin
③	Arm	Stainless Steel (SUS304)	—

Item Code	Item Name	Door Width	Door Height	Door Weight	Door Weight	Opening Angle	Weight	Box	Carton
170-095-018	I-66	Max.800	Max.2100	Max.30kg/2pcs	Max.50kg/3pcs	180°	100g	24pcs	240pcs

# CONCEALED HINGE



I-90



### Installation

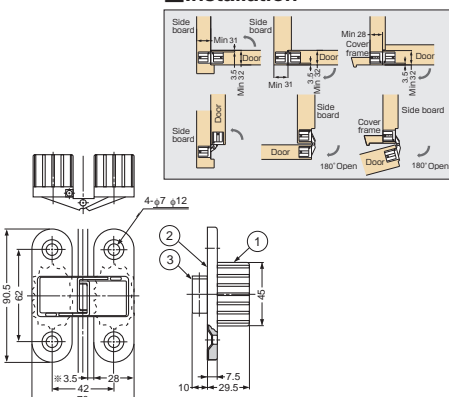

- Door weight:  
I-90 Max. 40kg/pair.  
Max. 60kg/3pcs.
- Limited stock available, please contact your local dealer for projects.

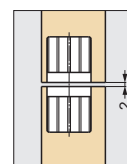

Distance between door edge and hinge must be less than 3.5mm.

No.	Part Name	Material	Finish
①	Body	Polyamide	Brown
②	FrontPlate	Stainless Steel (SUS304)	Satin
③	Arm	Stainless Steel (SUS304)	Satin

Item Code	Item Name	Door Weight	Door Weight	Opening Angle	Weight	Box	Carton
170-095-017	I-90	Max.40kg/2pcs	Max.60kg/3pcs	180°	115g	24pcs	240pcs

# DOUBLE ACTION HINGE



HG-BH

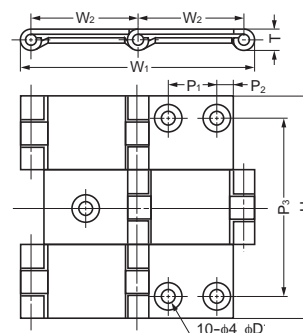

- Opens 180° in both left and right direction.
- Door Size: Max. W450 × H700 × t 21mm.

### Installation

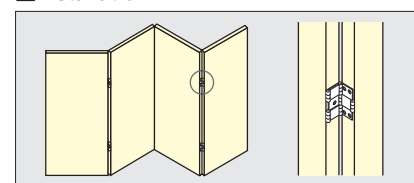

Item Code	Item Name	Material	Finish	H	W <sub>2</sub>	W <sub>1</sub>	T	P <sub>3</sub>	P <sub>2</sub>	P <sub>1</sub>	D	Door Width	Door Height	Door Weight	Weight	Box	Carton
170-090-065	HG-BH60	Stainless Steel (SUS304)	Satin	60	29	64	5.5	47	4.8	13.5	6.5	Max.450	Max.700	Max.2.6kg	65 g	20pcs	260pcs
170-090-066	HG-BH70	Stainless Steel (SUS304)	Satin	70	35	78	7.5	57	6.8	13.5	7	Max.450	Max.700	Max.2.6kg	130 g	10pcs	180pcs
170-090-067	HG-BH80	Stainless Steel (SUS304)	Satin	80	43.2	94	7.5	66	6.5	22	7	Max.450	Max.700	Max.2.6kg	175 g	10pcs	120pcs

# 3WAY ADJUSTABLE CONCEALED HINGE



# HES3D-190



- 3 WAY adjustment function allows vertical, horizontal, and depth adjustment after hinge is installed.
- Easy installation / removal.
- Successfully passed 200,000 open / close private cycle tests.
- Available in Matte Silver or Matte Gold finish.
- Supplied with stainless steel flat head screw. (Screw head painted).
- Door weight: Max. 70kg / 2pcs.
- Door Thickness: Min. 36mm.
- Max. Door Size: H 2400mm × W 900mm.
- Light duty version available.

Item Name	Finish / Color
HES3D-190SL	Matte Silver
HES3D-190GL	Matte Gold

Item Code	Item Name	Weight	Box	Carton
170-090-553	HES3D-190SL	940g	2pcs	12pcs
170-090-554	HES3D-190GL			

No.	Part Name	Material	Finish / Color
①	Body	Zinc Alloy	Matte Silver Matte Gold
②	Base Frame	Zinc Alloy	
③	Arm	Aluminum	
④	Shaft	304 Stainless Steel	—
⑤	Cover	ABS	Matte Silver, Matte Gold

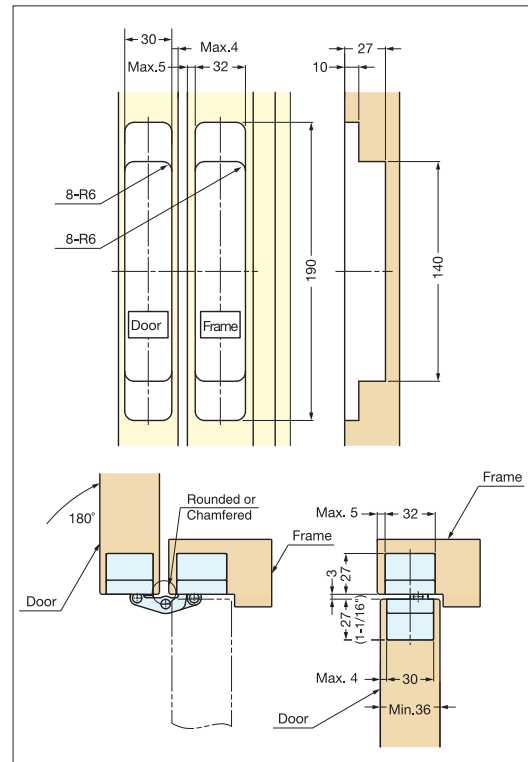
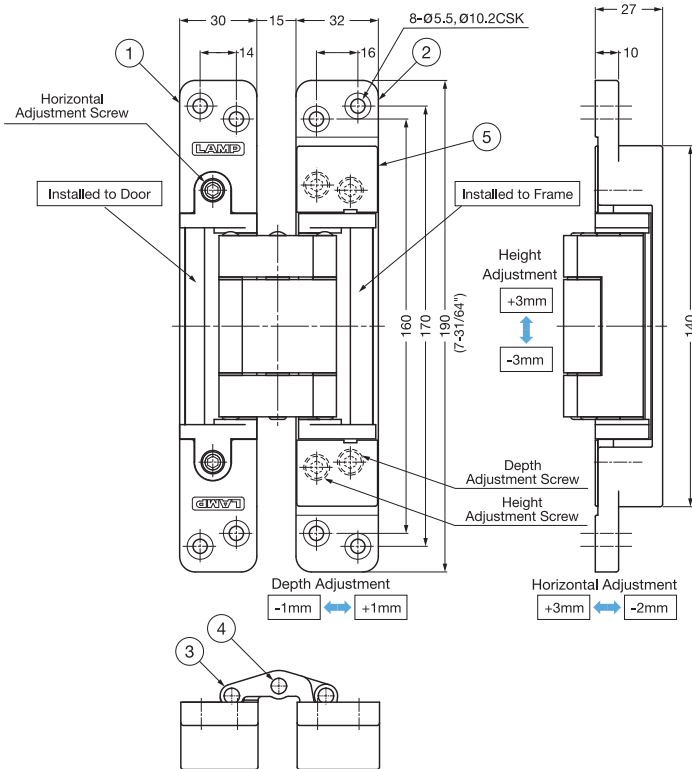

Bore Dimensions

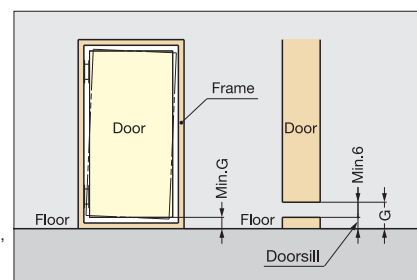

To determine the door and frame dimension, (G) must be taken into account.  
G = Min. 6mm + doorsill



# 3WAY ADJUSTABLE CONCEALED HINGE

# HES3D-120



- 3 WAY adjustment function allows vertical, horizontal, and depth adjustment after hinge installed.
- Easy installation / removal.
- Supplied with flat head screw.
- Cover hide all screws for clean appearance.
- Door weight : 30kgs (2 pcs/door), 40kgs (3pcs/door).
- Door thickness : Min. 29mm.
- Max. Door Size : H 2400mm × W 900mm.

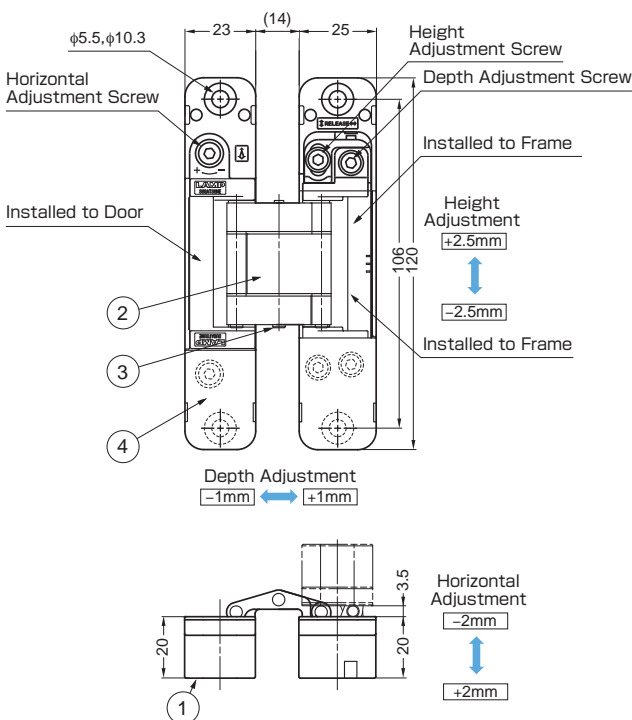
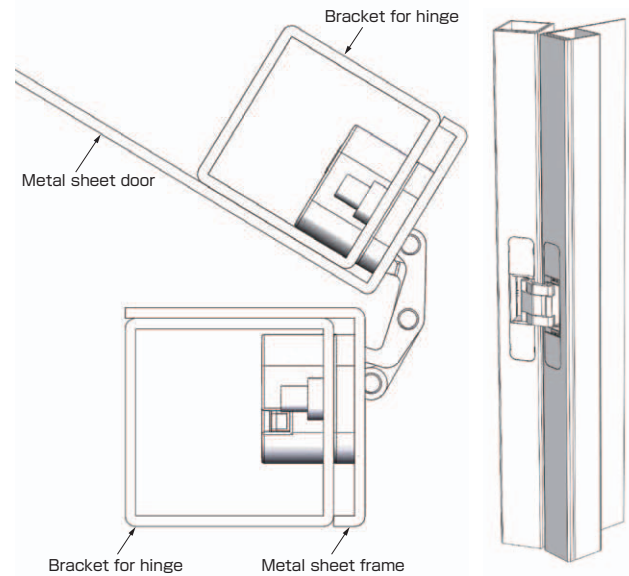

### Example of installation for metal sheet.

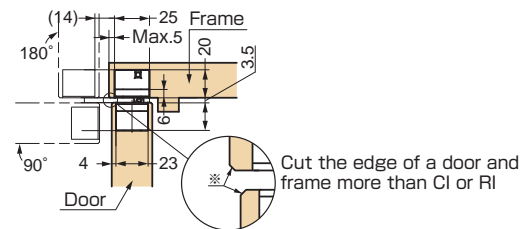

### Bore Dimensions

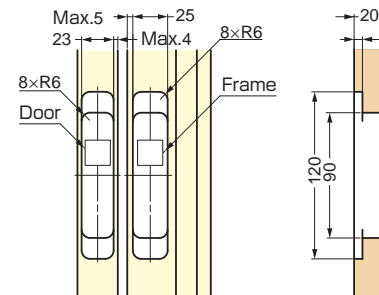

No.	Part Name	Material	Finish (Color)
①	Body	Zinc Alloy (ZDC)	Satin Chrome (Silver), Satin Nickel (Champagne Gold)
②	Arm	Zinc Alloy (ZDC)	Satin Chrome (Silver), Satin Nickel (Champagne Gold)
③	Shaft	Stainless Steel	—
④	Screw Cover	ABS	Satin Chrome (Silver), Satin Nickel (Champagne Gold)

Item Code	Item Name	Color	Door Width	Door Height	Door Thickness	Door Weight	Door Weight	Opening Angle
170-022-086	HES3D-120DC	Silver	Max.900	Max.2400	Min.29	Max.30kg/2pcs	Max.40kg/3pcs	180°
170-022-087	HES3D-120DN	Champagne Gold	Max.900	Max.2400	Min.29	Max.30kg/2pcs	Max.40kg/3pcs	180°

## CONCEALED HINGE

## 2000RV-2

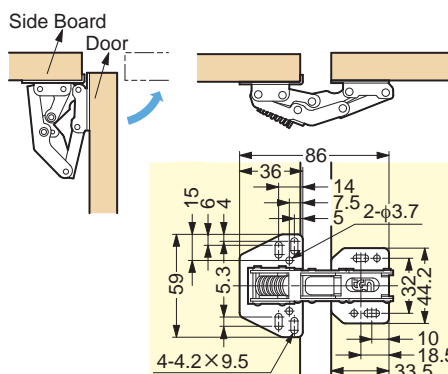

Item Code	Item Name	Material	Finish	Weight
170-090-034	2000RV-2	Steel	Nickel	93g

## CONCEALED HINGE

## 2000-150

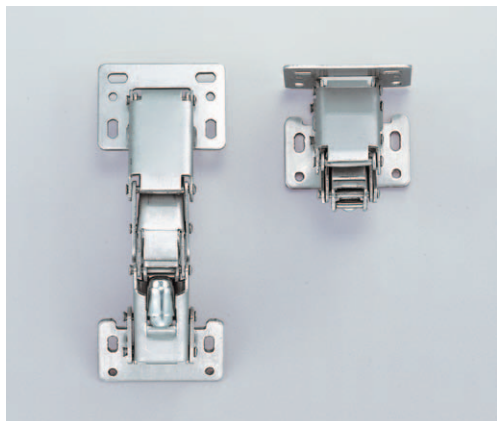

### Application

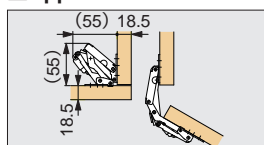

### No. of hinges based on door dimension

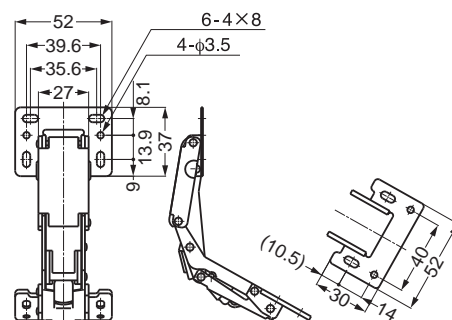
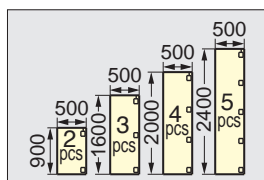

Item Code	Item Name	Material	Finish	Door Thickness	Opening Angle	Weight	Carton
170-090-884	2000-150	Steel	Nickel	Max.20	150°	149g	200pcs

## CONCEALED HINGE

## 2000-MIGNON



### Application

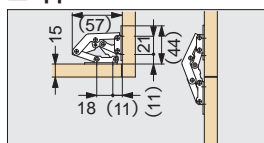

### No. of hinges based on door dimension

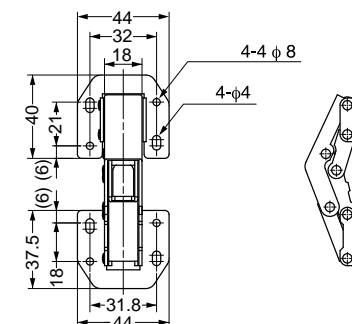
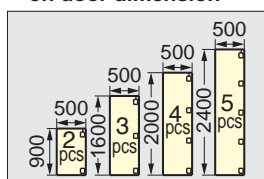

Item Code	Item Name	Material	Finish	Door Thickness	Opening Angle	Weight	Box	Carton
170-090-001	2000-MIGNON	Steel	Nickel	Max.20	90°	86g	20pcs	120pcs

# TORQUE HINGE



# HG-IT

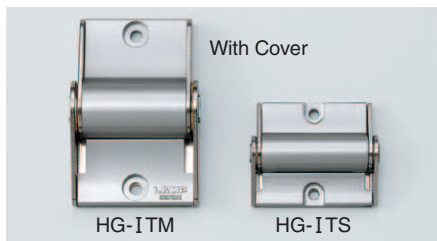

- Hinge with friction torque for holding monitors, displays etc. in desired position.
- Without friction torque available. (HG-ITSF, HG-ITMF)
- Optional cover available for clean appearance.
- Operating Temperature: -10°C ~ 50°C.

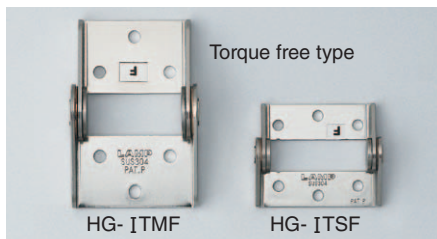

### Installation

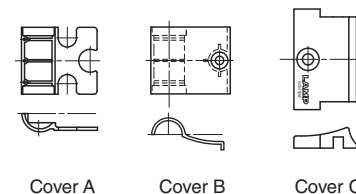
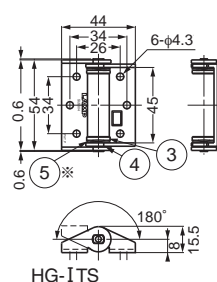
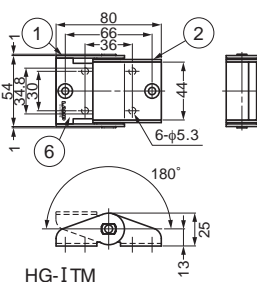
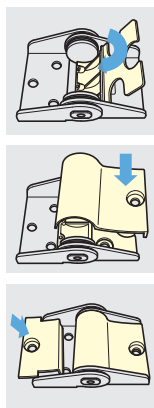

### Hinge

Item Code	Item Name	Torque Moment	Weight	Box	Carton
170-090-106	HG-ITS25	2.5N · m / 25.49kgf · cm	50g	20pcs	160pcs
170-090-115	HG-ITS35	3.5N · m / 35.69kgf · cm	50g	20pcs	160pcs
170-090-114	HG-ITM50	5.0N · m / 50.98kgf · cm	130g	10pcs	80pcs
170-090-113	HG-ITM70	7.0N · m / 71.38kgf · cm	130g	10pcs	80pcs
170-090-999	HG-ITSF	-	50g	20pcs	160pcs
170-090-998	HG-ITMF	-	130g	10pcs	80pcs

No.	Part Name	Material	Finish
①	Base	Stainless Steel (SUS304)	Polished
②	Bracket	Stainless Steel (SUS304)	Polished
③	Shaft	Stainless Steel (SUS303)	Plain
④	Washer	Phosphor Bronze	Polished
⑤	Spring Washer	Steel	Nickel
⑥	Cover	ABS	Silver

Not included in HG-ITSF HG-ITMF (Torque free type)

### Cover

Item Code	Item Name	Cover for	Weight	Box	Carton
170-091-002	HG-ITSC	HG-ITS Type	10g	40pcs	960pcs
170-091-001	HG-ITMC	HG-ITM Type	18g	20pcs	480pcs

# STAINLESS STEEL TORQUE HINGE



# SFTH

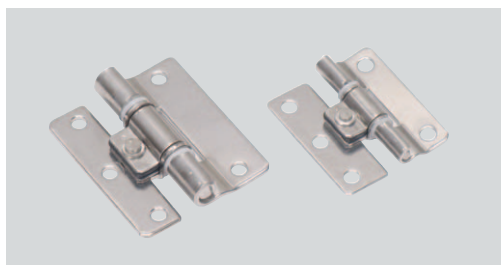

- Hinge with friction torque holds lid/door in desired position.
- Stainless steel construction for corrosive environments.
- Operating temperature: -20°C ~ 60°C.

No.	Part Name	Material	Finish
①	Body A	304 Stainless Steel	Polished
②	Shaft	303 Stainless Steel	
③	Body B	301 Stainless Steel	

Item Code	Item Name	Torque per piece	Weight	Box	Carton
170-098-199	SFTH-02-5	5±1kgf·cm	21g	50pcs	500pcs
170-098-198	SFTH-03-9	9±2kgf·cm	51g	30pcs	300pcs
170-098-197	SFTH-03-19	19±2kgf·cm			
170-098-196	SFTH-05-35	35±5kgf·cm	195g	10pcs	100pcs
170-098-200	SFTH-05-58	58±5kgf·cm			

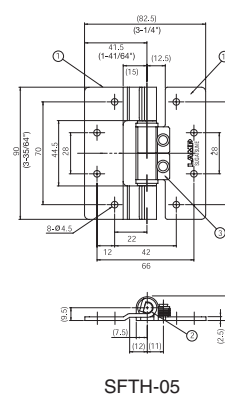
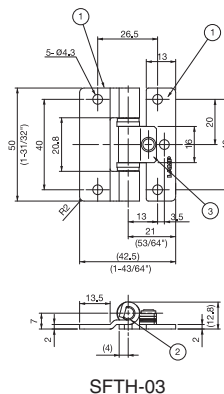
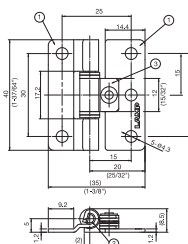

## TORQUE HINGE (DUAL AXIS)



### HG-T70S30



- Dual Axis: free stop at any angle in tilt & swivel.
- Provides torque stability in both directions.
- Suitable for monitor screens.

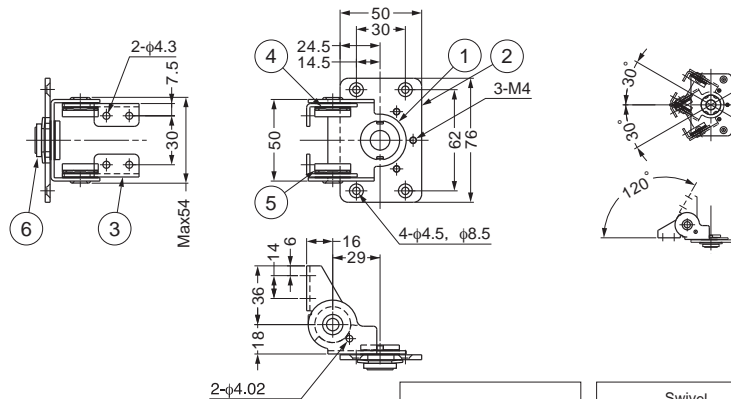

#### Cut Out Dimension

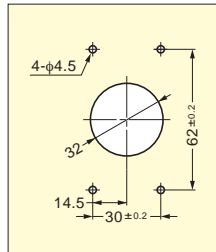
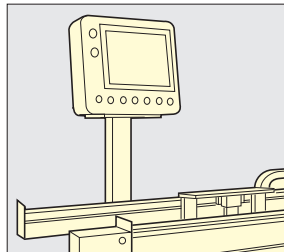

No.	Part Name	Material	Finish
①	Body	Stainless Steel (SUS430)	Polished
②	Base Plate	Stainless Steel (SUS430)	Polished
③	Bracket	Stainless Steel (SUS430)	Polished
④	Spring Washer	Steel	Plain
⑤	Shaft	Stainless Steel (SUS303)	Plain
⑥	Washer	Stainless Steel (SUS430)	Polished

Item Code	Item Name	Torque per piece (tilting)	Torque per piece (swiveling)	Weight (g)	Box	Carton		
170-012-419	HG-T70S30	7.0N.m	71.4kgf.cm	3.0N.m	30.6kgf.cm	232g	5pcs	40pcs

## TORQUE HINGE (DUAL AXIS)



### HG-T30S15

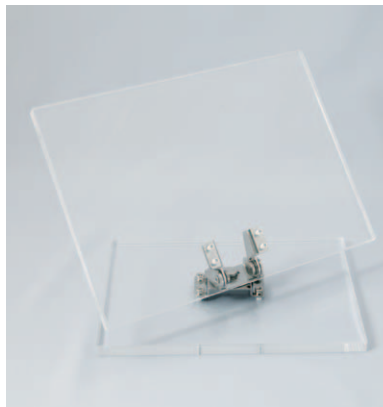
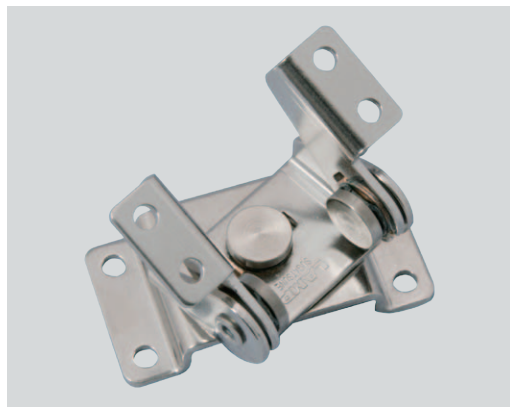

- Dual Axis: free stop at any angle in tilt & swivel.
- Provides torque stability in both directions.
- Suitable for monitor screens.

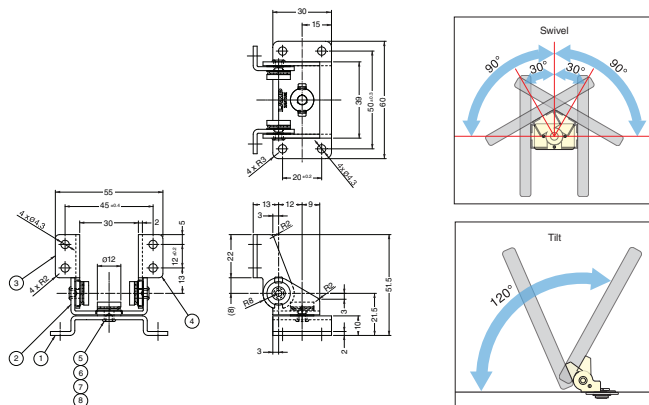

No.	Part Name	Material	Finish
①	Body	430 Stainless Steel	Polished
②	Base		
③	Bracket		
④	Shaft	303 Stainless Steel	-
⑤	Press Washer	Phosphor Bronze	Polished
⑥	Pin		-
⑦	Washer	Steel	-

Item Code	Item Name	Torque per piece (tilting)	Torque per piece (swiveling)	Weight (g)	Box	Carton		
170-020-826	HG-T30S15	2.9N.m	30.5kgf.cm	1.4N.m	14.9kgf.cm	92g	12pcs	96pcs

# TORQUE HINGE



# HG-TA



- Free stop hinge with friction torque.
- Consistent torque through out working range.
- Opening angle 0° ~ 140°

**Applications:**

- Ideal for indoor applications.
- LCD monitors, monitoring cameras, displays etc.

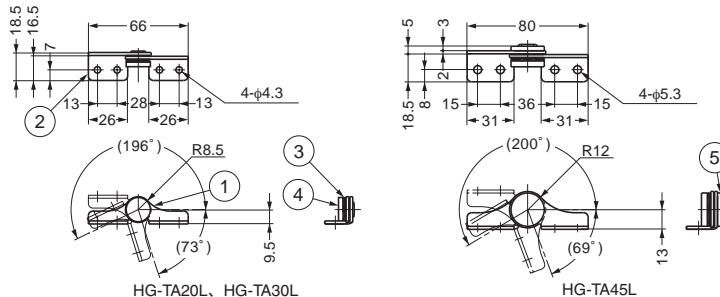

No.	Part Name	Material	Finish
①	Bracket	Stainless Steel (SUS430)	Mirror
②	Base	Stainless Steel (SUS430)	Mirror
③	Spring Washer	Steel	-
④	Shaft	Stainless Steel (SUS303)	-
⑤	Washer	Stainless Steel (SUS430)	-

Item Code	Item Name	Spec.	Torque Moment		Weight	Box	Carton
170-012-403	HG-TA20R	Right	2.0N · m	20.4kgf · cm	30g	40pcs	320pcs
170-012-404	HG-TA20L	Left	2.0N · m	20.4kgf · cm	30g	40pcs	320pcs
170-012-405	HG-TA30R	Right	3.0N · m	30.6kgf · cm	30g	40pcs	320pcs
170-012-406	HG-TA30L	Left	3.0N · m	30.6kgf · cm	30g	40pcs	320pcs
170-012-407	HG-TA45R	Right	4.5N · m	45.9kgf · cm	65g	20pcs	160pcs
170-012-408	HG-TA45L	Left	4.5N · m	45.9kgf · cm	65g	20pcs	160pcs

# TORQUE HINGE



# HG-TB



- Free stop hinge with friction torque.
- Consistent torque through out working range.
- Opening angle 360°

**Applications:**

- Ideal for indoor applications.
- LCD monitors, monitoring cameras, displays etc.

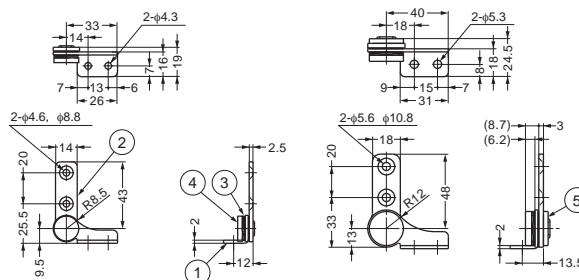

No.	Part Name	Material	Finish
①	Bracket	Stainless Steel (SUS430)	Mirror
②	Base	Stainless Steel (SUS430)	Mirror
③	Spring Washer	Steel	-
④	Shaft	Stainless Steel (SUS303)	-
⑤	Washer	Stainless Steel (SUS430)	-

**Applications**

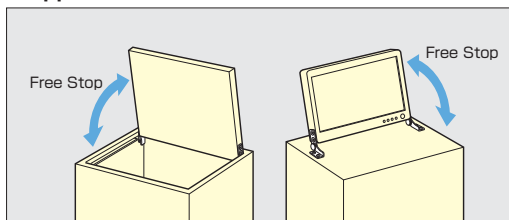

Item Code	Item Name	Spec.	Torque Moment		Weight	Box	Carton
170-012-413	HG-TB20R	Right	2.0N · m	20.4kgf · cm	30g	40pcs	320pcs
170-012-414	HG-TB20L	Left	2.0N · m	20.4kgf · cm	30g	40pcs	320pcs
170-012-415	HG-TB30R	Right	3.0N · m	30.6kgf · cm	30g	40pcs	320pcs
170-012-416	HG-TB30L	Left	3.0N · m	30.6kgf · cm	30g	40pcs	320pcs
170-012-417	HG-TB45R	Right	4.5N · m	45.9kgf · cm	65g	20pcs	160pcs
170-012-418	HG-TB45L	Left	4.5N · m	45.9kgf · cm	65g	20pcs	160pcs

# STAINLESS STEEL TORQUE HINGE



## HG-TS

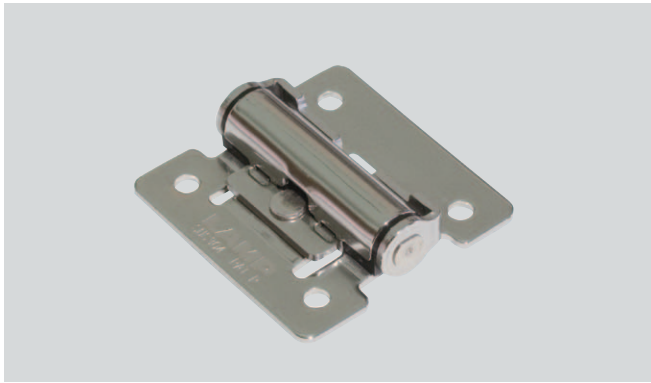

- Hinge with friction torque holds lid/door in desired position.
- Stainless steel material ideal for harsh environments.
- Best durability on continuous open/close cycle.
- Free stop between 0-180 degrees.
- RoHS Compliant.
- Initial torque may vary -20%~+40%.

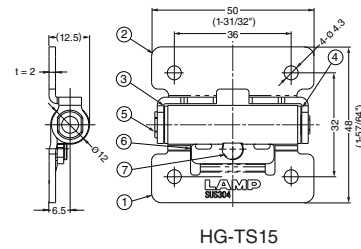
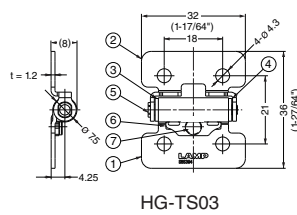
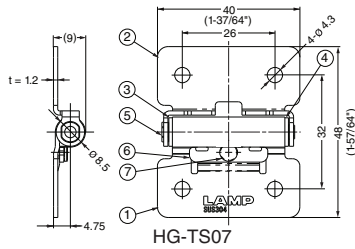

Item Code	Item Name	Torque per piece	
170-018-501	HG-TS03	0.35 N.m	3.6 kgf · cm
170-018-502	HG-TS07	0.7 N.m	7.1 kgf · cm
170-018-503	HG-TS15	1.5 N.m	15.3 kgf · cm

No.	Part Name	Material	Finish
①	Body	Stainless Steel (SUS 304)	Polished
②	Base		
③	Fixing Tube	Polyacetal	Black
④	Fixing Tube		
⑤	Shaft	Stainless Steel (SUS 303)	-
⑥	Press Washer	Stainless Steel(SUS 304)	Polished
⑦	Pin		-

# HIDDEN TORQUE HINGE



## HG-TU



### SPECIFICATIONS:

- Installation on the back side of the door.
- Can be used both for horizontal and vertical applications.

### REMARKS:

- Initial torque may vary -20%~+40%.
- Not suitable for high frequency use.
- Do not lubricate.
- For indoor use only.

### Installation

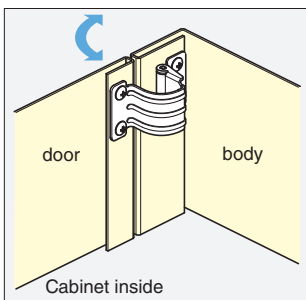

### Installation drawing

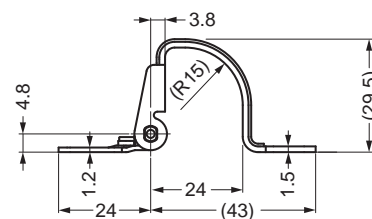
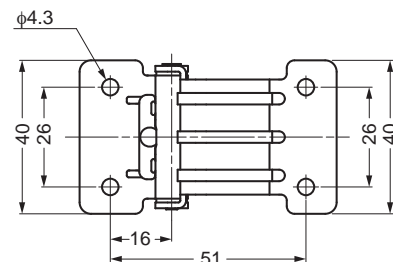
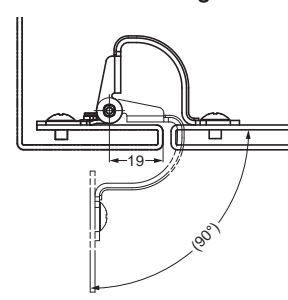

Item Code	Item Name	Material	Finish	Torque Moment		Weight	Box	Carton
170-022-304	HG-TU03	Stainless Steel (SUS304)	Mirror	0.35N · m	3.6kgf · cm	50g	20pcs	200pcs
170-022-305	HG-TU07	Stainless Steel (SUS304)	Mirror	0.7N · m	7.1kgf · cm	50g	20pcs	200pcs

# SWIVEL TORQUE HINGE



## HG-S



- SPECIFICATIONS:**
- Rotation angle: 360°
  - Free stop function.

- APPLICATION:**
- Industrial control panels and monitors.

- REMARKS:**
- Initial torque may vary  $\pm 20\%$ .
  - Not suitable for high frequency use.
  - Do not lubricate.
  - For indoor use only.

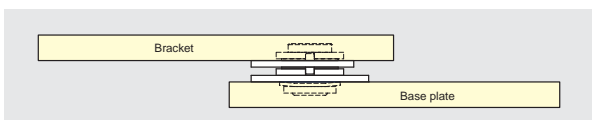
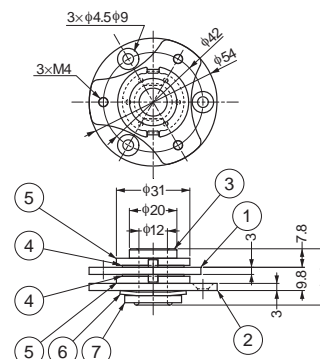
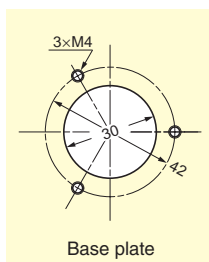
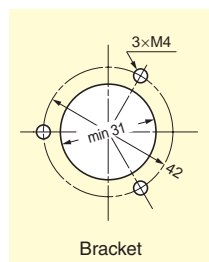
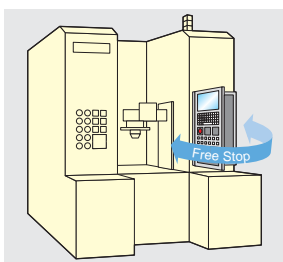

Item Code	Item Name	Torque Moment	
170-021-976	HG-S30-12	3.0N · m	30.6kgf · cm
170-021-975	HG-S50-12	5.0N · m	51.0kgf · cm

Request-based torque up to 5.0N · m is possible: please contact your local dealer.

No.	Part Name	Material	Finish
①	Bracket	Stainless Steel (SUS430)	Mirror
②	Base plate	Stainless Steel (SUS430)	Mirror
③	Sleeve	Stainless Steel (SUS303)	—
④	Fplate	Bronze	—
⑤	Washer	Stainless Steel (SUS430)	Mirror
⑥	Spring	Steel	—
⑦	Washer	Stainless Steel (SUS430)	Plain

# TORQUE HINGE



## SK-T-ZA



Body without cover



with cover

- Hinge with friction torque for holding monitors, displays, lids etc. in desired position.
- Plastic cover provided for clean appearance.
- Recommended for use in pairs.
- Lubricant should not be applied on hinge.

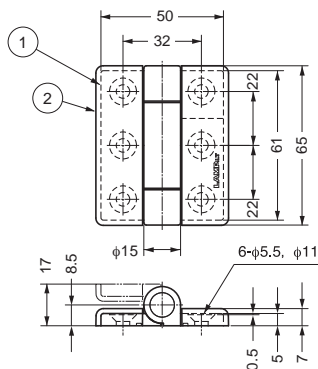

No.	Part Name	Material	Finish
①	Body	Zinc Alloy	Satin Chrome, Chrome
②	Cover	ABS	Satin Chrome, Chrome

Item Code	Item Name	Finish	Torque Moment	
170-090-797	SK-T-ZA-1SCR	Satin Chrome	2.94N · m	30kgf · cm
170-090-799	SK-T-ZA-2SCR	Satin Chrome	1.96N · m	20kgf · cm
170-090-801	SK-T-ZA-3SCR	Satin Chrome	1.47N · m	15kgf · cm
170-090-796	SK-T-ZA-1CR	Chrome	2.94N · m	30kgf · cm
170-090-798	SK-T-ZA-2CR	Chrome	1.96N · m	20kgf · cm
170-090-800	SK-T-ZA-3CR	Chrome	1.47N · m	15kgf · cm

# ONE WAY TORQUE HINGE



**SPECIFICATIONS:**

- Aluminum torque hinge.
- Friction in one direction only: allows for frictionless handling of the door in the opposite direction.
- Tested to 30,000 cycles.
- Torque is constant in torque direction.
- Sold in pairs (Left/Right).

**POSSIBLE USE:**

- Ideal to prevent shock to the door and/or safety: Medical applications, FA applications, OA applications.

**REMARKS:**

- Initial torque may vary -20%~+40%.
- Not suited to vibration environment.
- Torque will be affected by temperature.
- Not suitable for high frequency use.
- Do not lubricate.
- For indoor use only."

**Torque and free stop range**

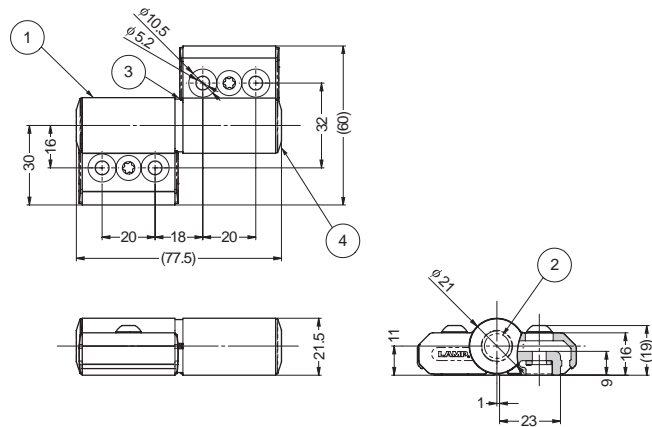
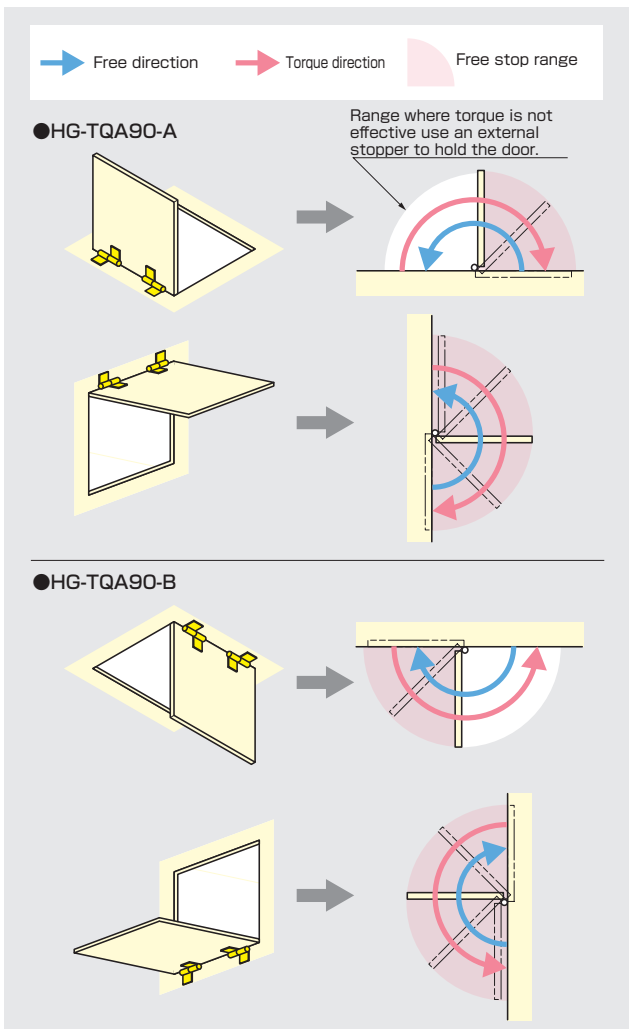

**Installation**

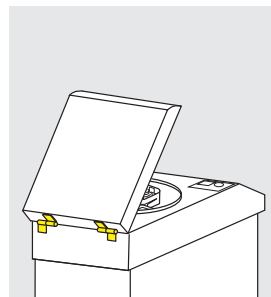

No.	Part Name	Material	Finish
①	Body	Aluminum Alloy	Anodized
②	Arm Shaft	Stainless Steel	Plain
③	Sleeve	Polyacetal (POM)	Black
④	Cover	Polyacetal (POM)	Black

Item Code	Item Name	Torque Moment (per set)		Weight	Box
170-021-244	HG-TQA90-A	9.0N · m	91.8kgf · cm	270g	10sets
170-021-245	HG-TQA90-B	9.0N · m	91.8kgf · cm	270g	10sets



## CELL PHONE HINGE (W/DETENT)



## MPH-30-5TN

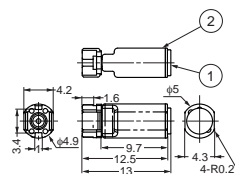

### Installation



- Ultra compact detent hinge ideal for clamshell type cell phone, PDA and other foldable device.
- Designed for 160° opening.
- Detent catch in open and closed position.
- Friction torque moment provided to lightly hold device in any middle angle.
- Easy snap-in for quick assembly.
- Unhanded for easy manufacturing process.
- Passed private 100,000 open/close cycle test.
- Application:
  - Cell phone
  - PDA
  - Head set
  - Gaming device
  - Webcam

Item Code	Item Name	Opening Angle	Weight	Carton
170-097-888	MPH-30-5TN	160°	0.86g	4000pcs

No.	Part Name	Material	Finish
①	Spindle	Steel	Clear Zinc Chrome
②	Body	Stainless Steel	—

## CELL PHONE HINGE (W/DETENT)



## MPH-20-5G2

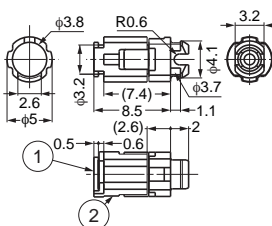

- Ultra compact detent hinge ideal for clamshell type cell phone, PDA and other foldable device.
- Designed for 160° opening.
- Detent catch in open and closed position.
- Friction torque moment provided to lightly hold device in any middle angle.
- Easy snap-in for quick assembly.
- Unhanded for easy manufacturing process.
- Passed private 100,000 open/close cycle test.
- Application:
  - Cell phone
  - PDA
  - Head set
  - Gaming device
  - Webcam

Item Code	Item Name	Opening Angle	Weight	Carton
170-090-536	MPH-20-5G2	160°	0.46g	4000pcs

No.	Part Name	Material	Finish/Color
①	Spindle	Steel	Clear Zinc Chrome
②	Body	Polyacetal	White

## CELL PHONE HINGE (W/DETENT)



## MPH-30

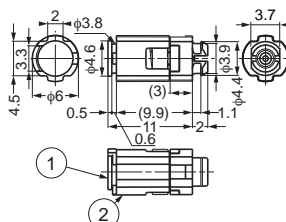

- Ultra compact detent hinge ideal for clamshell type cell phone, PDA and other foldable device.
- Designed for 160° opening.
- Detent catch in open and closed position.
- Friction torque moment provided to lightly hold device in any middle angle.
- Easy snap-in for quick assembly.
- Unhanded for easy manufacturing process.
- Passed private 100,000 open/close cycle test.
- Application:
  - Cell phone
  - PDA
  - Head set
  - Gaming device
  - Webcam

Item Code	Item Name	Opening Angle	Weight	Carton
170-090-024	MPH-30	160°	0.98g	4000pcs

No.	Part Name	Material	Finish/Color
①	Spindle	Steel	Clear Zinc Chrome
②	Body	Polyacetal	Black

## CELL PHONE HINGE (W/DETENT)



## MPH-22G

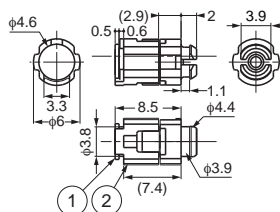

- Ultra compact detent hinge ideal for clamshell type cell phone, PDA and other foldable device.
- Designed for 160° opening.
- Detent catch in open and closed position.
- Friction torque moment provided to lightly hold device in any middle angle.
- Easy snap-in for quick assembly.
- Unhanded for easy manufacturing process.
- Passed private 100,000 open/close cycle test.
- Application:
  - Cell phone
  - PDA
  - Head set
  - Gaming device
  - Webcam

Item Code	Item Name	Opening Angle	Weight	Carton
170-098-727	MPH-22G	160°	0.62g	4000pcs

No.	Part Name	Material	Finish/Color
①	Spindle	Steel	Clear Zinc Chrome
②	Body	Polyacetal	Grey

# STAINLESS STEEL LIFT ASSIST HINGE



# HG-JH210



- Spring assists in opening heavy doors.
- Built-in damper keeps lid from slamming shut.
- Passed private 30,000 open/close cycle tests.
- Maximum torque: 210 kgf·cm per piece.

### Installation

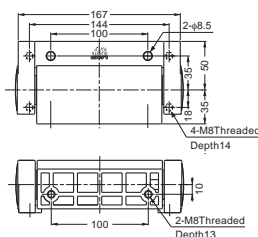
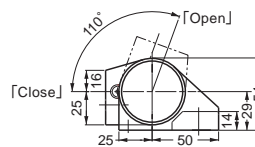
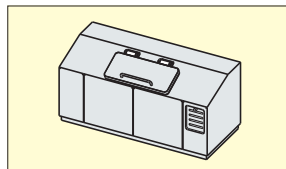

### Moment Formula and Graph

**Door Moment**  $M_t = W \times \frac{L}{2} \times \cos \theta$

**Hinge Moment**  $M_h = M_m \times (1 - \frac{\theta}{115})$

**Torque to lift door**  $M_z = M_h - M_t$

**Force to lift door**  $F = \frac{M_t - M_h}{L}$

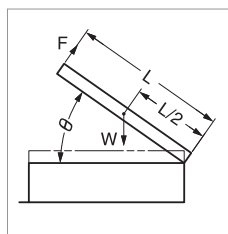

W : Door Weight    θ : Opening Angle  
L : Door Length    Mm : Torque of Assist Hinge

When Mz is:  
"-" shows closing force. "+" shows opening force.

### Assist Hinge Moment

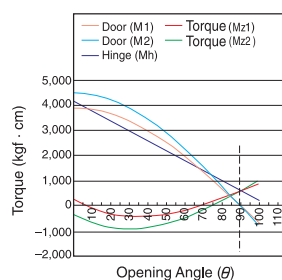

### Working Force at opening Angle (Compared with No Assist)

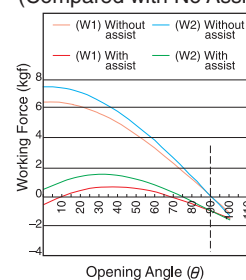

\*In case of JH-210 used in pair. (L: 60cm, W1: 13kg, W2:15kg)

Item Code	Item Name	Material (※)	Finish	Opening Angle
170-090-535	HG-JH210	Stainless Steel (SCS14)	Mirror	110°

(※) SCS14 is Similar to SUS316

# DETENT HINGE (WITH or WITHOUT DAMPER)



# HG-CSH63



- Detent hinge with built-in damper as an option.
- Detent will hold lid in open/closed position without secondary support, and optional damper will provide soft closing.
- Operating angle: 100° (Detent at both 0° and 100°)
- Detent holding force: 10.2 kgf·cm
- Damper torque range: 10.2~25.5 kgf·cm/pc

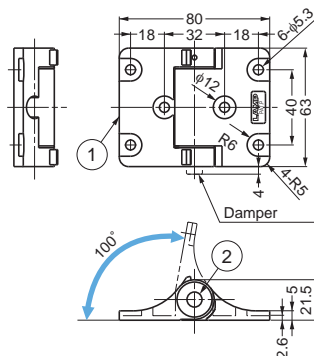

### Installation

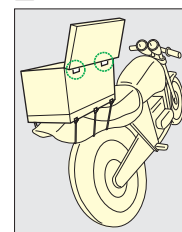

### Installation drawing

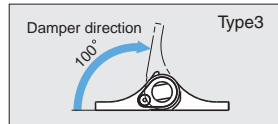
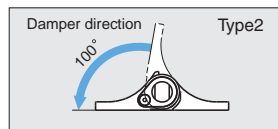
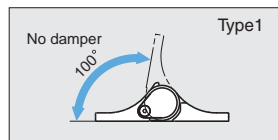
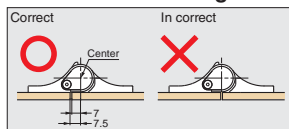

No.	Part Name	Material	Finish
①	Body	Aluminum Alloy	Silver
②	Shaft · Spring	Stainless Steel (SUS304)	-

Item Code	Item Name	Type	Detent	Damper Working Direction	Torque Moment	Detent Retaining Force	Opening Angle	Weight		
170-090-044	HG-CSH63	1	With	-	-	98N · cm/1pcs	10kgf · cm/1pcs	100°	98.7g	
170-090-108	HG-CSH63AH	2	With	Counter Clockwise	170~250N · cm	17.3~25.5kgf · cm	98N · cm/1pcs	10kgf · cm/1pcs	100°	114.3g
170-090-109	HG-CSH63AM	2	With	Counter Clockwise	100~170N · cm	10.2~17.3kgf · cm	98N · cm/1pcs	10kgf · cm/1pcs	100°	114.3g
170-090-110	HG-CSH63BH	3	With	Clockwise	170~250N · cm	17.3~25.5kgf · cm	98N · cm/1pcs	10kgf · cm/1pcs	100°	114.3g
170-090-111	HG-CSH63BM	3	With	Clockwise	100~170N · cm	10.2~17.3kgf · cm	98N · cm/1pcs	10kgf · cm/1pcs	100°	114.3g

SOFT-CLOSE DAMPENING HINGE



HG-JHW / HG-JHWG



- Soft-Close damper keeps lid from slamming shut.
- Surface mount type.
- Two different damper direction available for various applications.
- Operating temperature: 0~40°C.
- Operating angle: 115° / Dead angle 5°.
- Sold per piece.

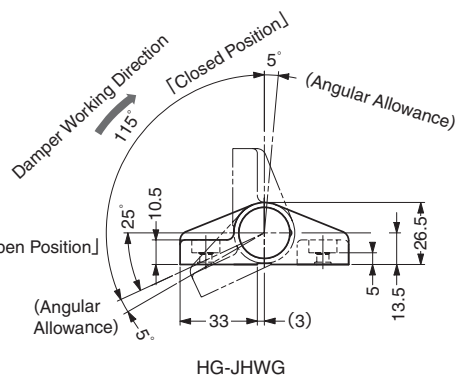
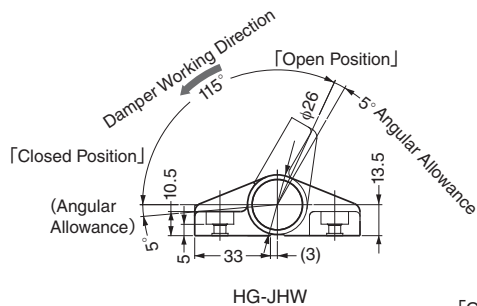
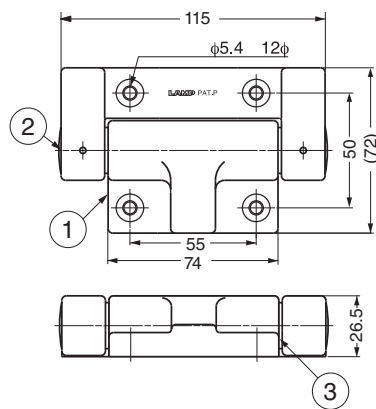
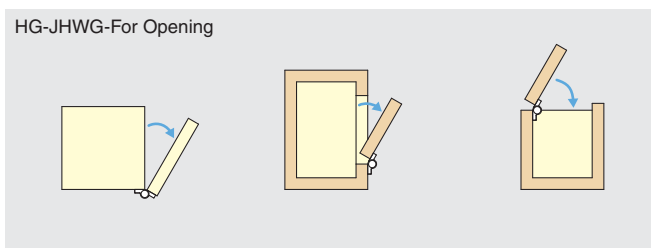
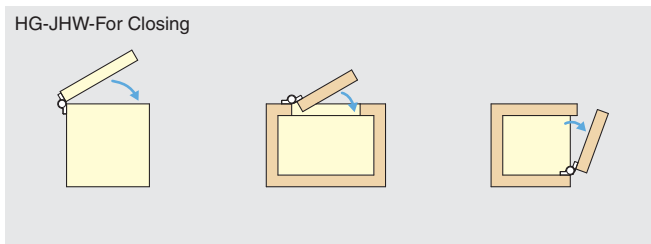

No.	Part Name	Material	Finish
①	Bracket	PBT Plastic/Zinc Alloy	Dark Grey
②	Cover	Polypropylene	Dark Grey
③	Damper	Stainless Steel	—

Item Code	Item Name	Damper Working Direction	Torque Moment(pair)		Marking color(Backside)	Box	Carton
170-092-212	HG-JHW50	For Closing	600~1000N·cm	61.2~102kgf·cm	White	4pcs	64pcs
170-092-211	HG-JHW70	For Closing	1000~1400N·cm	102 ~142.8kgf·cm	Without	4pcs	64pcs
170-092-215	HG-JHW50G	For Opening	600~1000N·cm	61.2~102kgf·cm	White · Red	4pcs	64pcs
170-092-216	HG-JHW70G	For Opening	1000~1400N·cm	102 ~142.8kgf·cm	Red	4pcs	64pcs

# SOFT-CLOSE DAMPENING HINGE



HG-JH



- Soft-Close damper keeps lid from slamming shut.
- Surface mount type.
- Operating temperature: 0~40°C.
- Operating angle: 115° / Dead angle 5°.
- Sold in pairs.

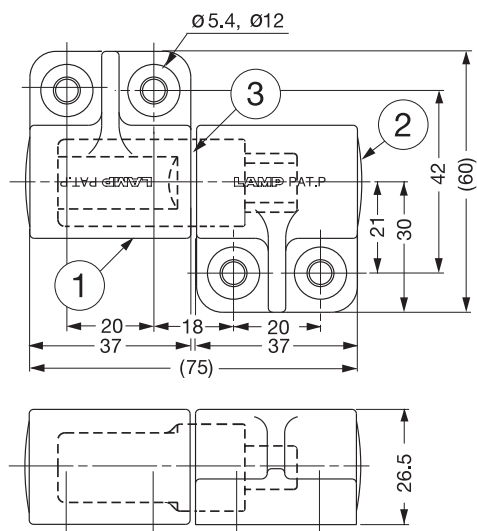

Left-Hand Damper is shown

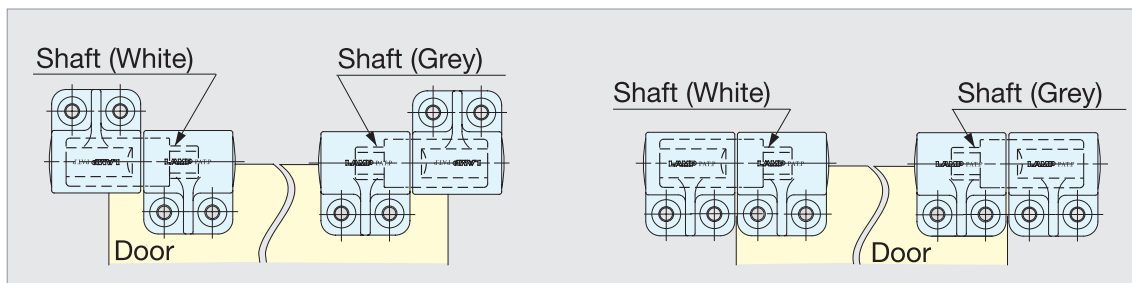
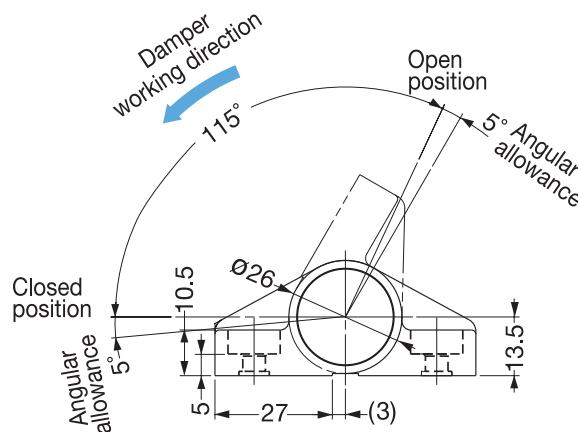

Installation

No.	Part Name	Material	Finish/Color
①	Bracket	PBT Plastic/Zinc Alloy	Dark Grey
②	Cover	Polypropylene	Dark Grey
③	Damper	Stainless Steel	—

Item Code	Item Name	Damper Bottom Color	Torque Moment(pair)		Box	Carton
170-092-209	HG-JH25	Blue	300~500N·cm	30.6~51kgf·cm	4set	64set
170-092-210	HG-JH35	Red	500~700N·cm	51~71.4kgf·cm	4set	64set

STAINLESS STEEL SOFT-CLOSE DAMPENING HINGE



HG-JH14-50



- Soft-Close damper keeps lid from slamming shut.
- Surface mount type.
- Operating temperature: 0~40°C.
- Operating angle: 115° / Dead angle 5°.
- Sold in pairs.

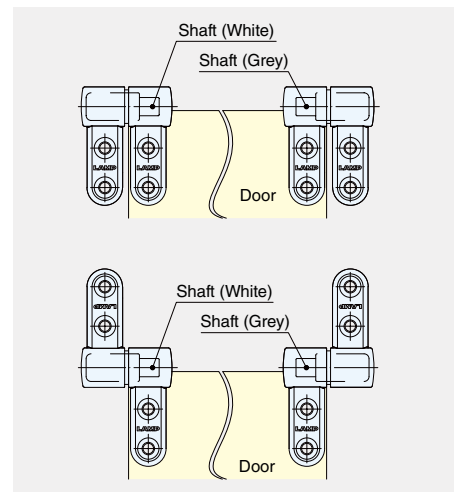
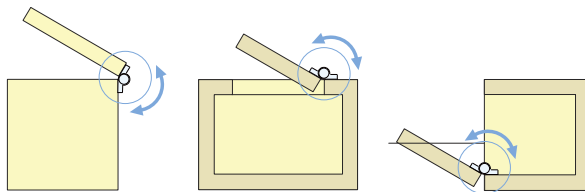

Installation

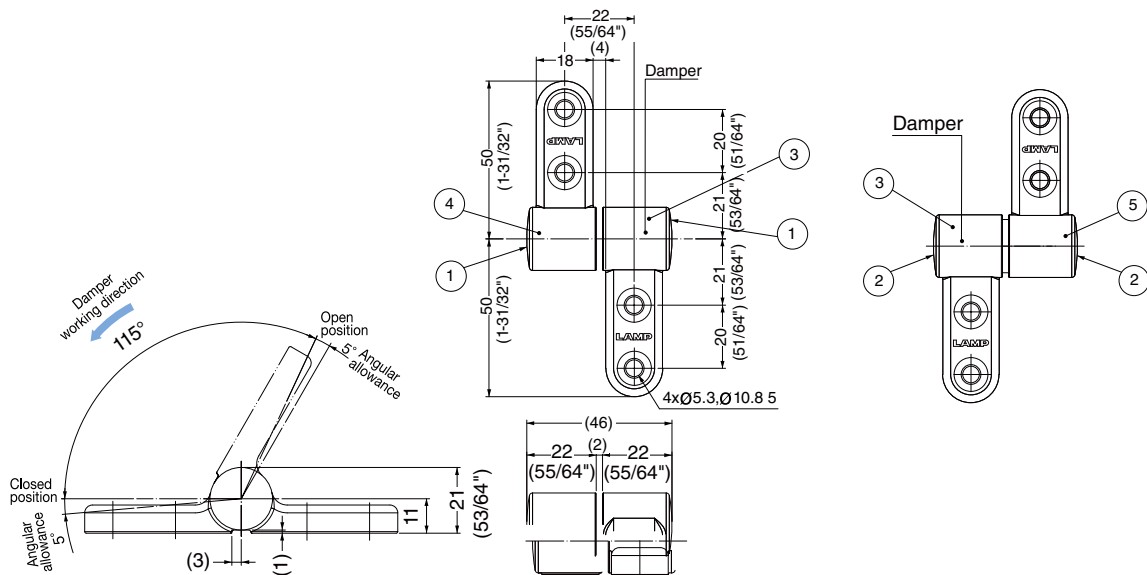

No.	Part Name	Material	Finish
①	Bracket	Stainless Steel (SCS13)	Mirror
②	Damper	Stainless Steel	Plain

\*SCS13 is similar to SUS304

Item Code	Item Name	Torque per pair	Weight	Box	Carton
170-021-173	HG-JH14-50	30~51kgf·cm	275g	8pairs	48pairs

# SOFT-CLOSE DAMPENING HINGE



## HG-JHM20



- Hinge with built-in damper to keep lid from slamming shut.
- Mortise mount type.
- Ideal for small size lid.
- Sold in pairs.
- Torque Calculation:

$$T = m \times 9.8 \times L$$

T: Max. lid torque (cN·m)

m: Lid weight (kg)

L: Length from axis to center of gravity of the lid (cm)

$$L = D/2 - A$$

D: Lid length (cm)

A: Length from axis to the edge of the lid (cm)

Example:

D=45 cm, A=3.6 cm, m=4.32 kg

$$T = 4.32 \times 9.8 \times (45/2 - 3.6) = 800 \text{ (cN·m)} = 8.0 \text{ (N·m)}$$

\* Please see diagram below for applicable torque moment.

\* Please specify face plate color when ordering.

\* Please install Left and Right brackets on correct side.



Black Set



White Set

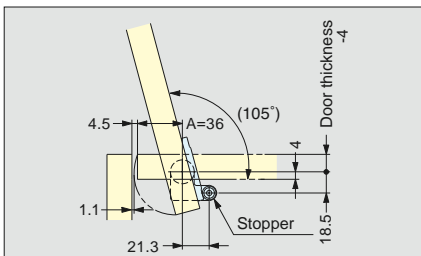
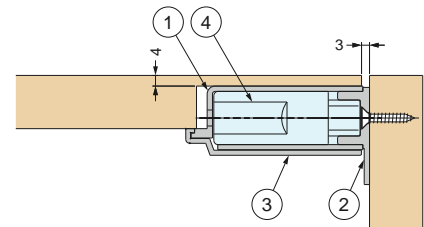
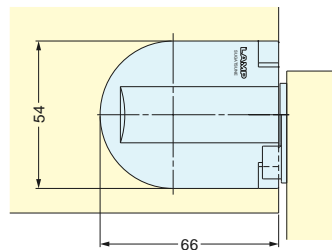
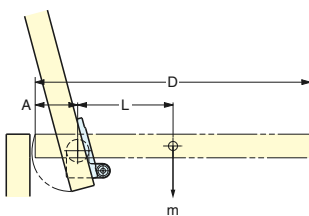
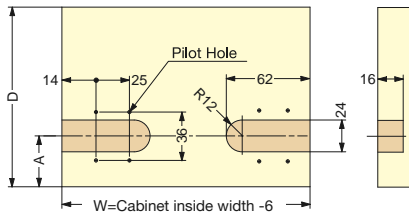
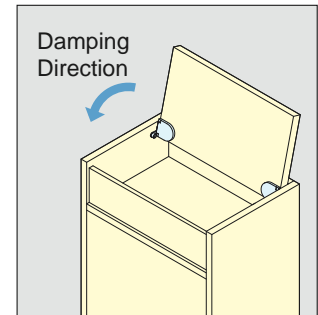

Standard Installation

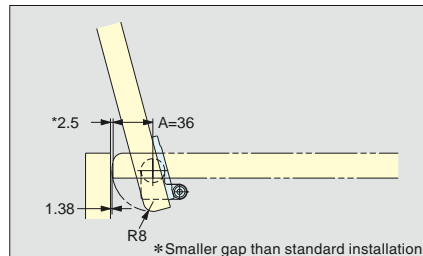

Installation with Rounded Lid Edge

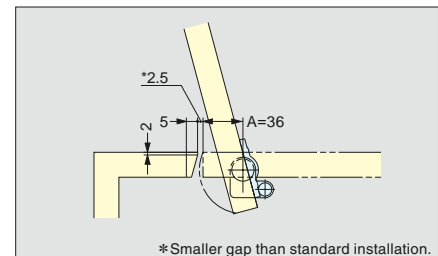

Installation with Inclined Edge

### ■ Criterion of Door Weight

No.	Part Name	Material	Finish/Color
①	Bracket	Polyacetal	Black
②	Strike	Aluminum Alloy	Baking Finish/Black
③	Cover	ABS	Matt/Black or White
④	Damper	-	-

Door Height	Door Weight
250	6.58 ~ 8.77 kg
300	5.18 ~ 6.91 kg
350	4.28 ~ 5.70 kg
400	3.64 ~ 4.86 kg
450	3.17 ~ 4.23 kg

Item Code	Item Name	Color	Torque Moment	Weight	Box	Carton
170-012-854	HG-JHM20-80BL	Black	600~800cN·m 61.2~81.6kgf·cm	206g	10pairs	90pairs
170-012-855	HG-JHM20-80WT	White	600~800cN·m 61.2~81.6kgf·cm	206g	10pairs	90pairs

# SOFT-CLOSE DAMPENING HINGE



# HG-JHM16



- Hinge with built-in damper to keep lid from slamming shut.
- Mortise mount type.
- Ideal for small size lid.
- Sold in pairs.
- Torque Calculation:

$$T = m \times 9.8 \times L$$

T: Max. lid torque (cN·m)

m: Lid weight (kg)

L: Length from axis to center of gravity of the lid (cm)

$$L = D/2 - A$$

D: Lid length (cm)

A: Length from axis to the edge of the lid (cm)

Example:

D=43 cm, A=3.2 cm, m=2.78 kg

$$T = 2.78 \times 9.8 \times (43/2 - 3.2) = 499 \text{ (cN·m)} = 5.0 \text{ (N·m)}$$

\*Please see diagram below for applicable torque moment.

\*Please specify face plate color when ordering.

\*Please install Left and Right brackets on correct side.

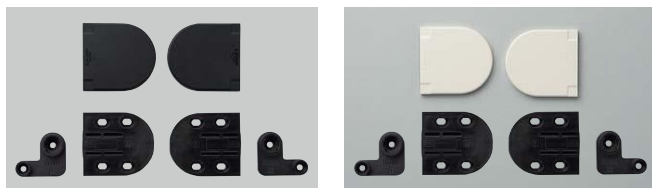

Black Set

White Set

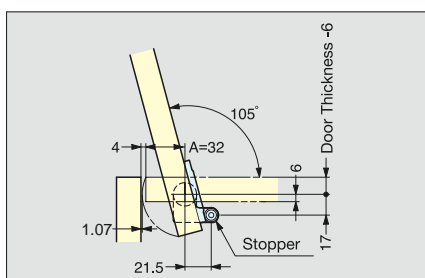
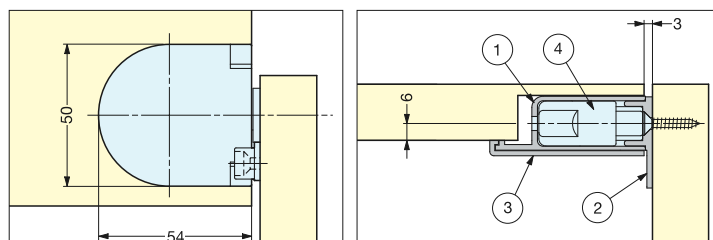
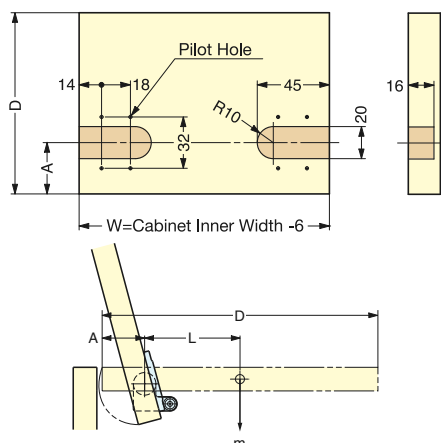
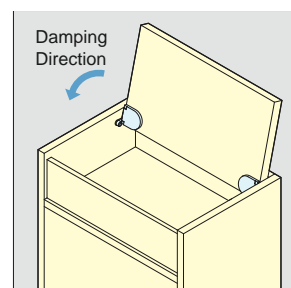

Standard Installation

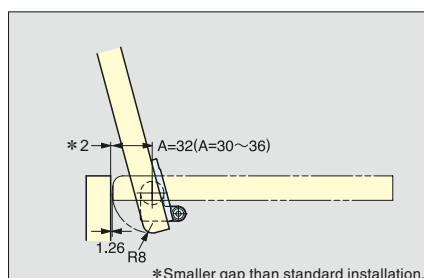

Installation with Rounded Lid Edge

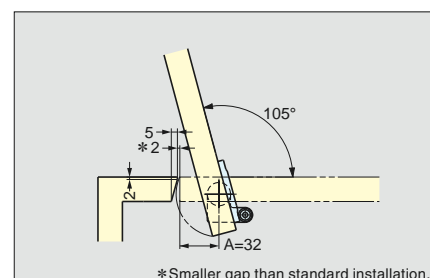

Installation with Inclined Edge

### ■ Criterion of Door Weight

No.	Part Name	Material	Finish/Color
①	Bracket	Polyacetal	Black
②	Strike	Aluminum Alloy	Baking Finish/Black
③	Cover	ABS	Matt/Black or White
④	Damper	-	-

Door Height	Door Weight	
	HG-JHM16-34	HG-JHM16-50
250	2.19 ~ 3.73 kg	3.73 ~ 5.48 kg
300	1.73 ~ 2.94 kg	2.94 ~ 4.32 kg
350	1.43 ~ 2.42 kg	2.42 ~ 3.57 kg
400	1.21 ~ 2.06 kg	2.06 ~ 3.03 kg
450	1.06 ~ 1.80 kg	1.80 ~ 2.64 kg

Item Code	Item Name	Color	Torque Moment	Weight	Box	Carton
170-092-221	HG-JHM16-34BL	Black	200~340cN·m 20.4~34.7kgf·cm	103g	10pairs	120pairs
170-092-222	HG-JHM16-34WT	White	200~340cN·m 20.4~34.7kgf·cm	103g	10pairs	120pairs
170-092-223	HG-JHM16-50BL	Black	340~500cN·m 34.7~51.0kgf·cm	103g	10pairs	120pairs
170-092-224	HG-JHM16-50WT	White	340~500cN·m 34.7~51.0kgf·cm	103g	10pairs	120pairs







## HANDLES, PULLS & KNOBS

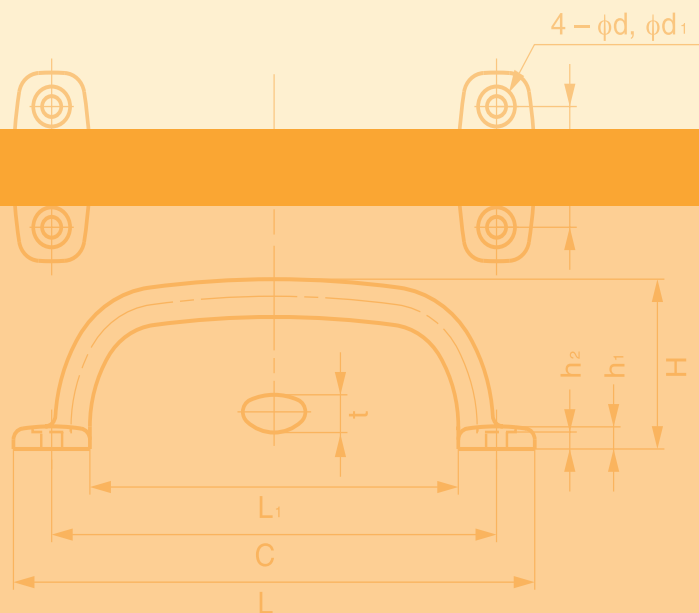



LARGE HANDLE







Picture	Item Name		Page
	MP	STAINLESS 316 STEEL	340
	SSH	STAINLESS 304 STEEL	340
	RH-760	STAINLESS 304 STEEL	341
	SOR	ALUMINIUM	341

Picture	Item Name		Page
	XL-JSR	STAINLESS 316 STEEL	352
	XL-CU	STAINLESS 303 STEEL	352
	XL-CUR	STAINLESS 303 STEEL	353
	FB	STAINLESS 304 STEEL	353
	KPH	STAINLESS 304 STEEL	353

HANDLES (Back Screw Mount)





Picture	Item Name		Page
	I1014	STAINLESS 304 STEEL	342
	I1020	STAINLESS 430 STEEL	342
	I333	STAINLESS 430 STEEL	342
	I120	STAINLESS 304 STEEL	343
	I100	STAINLESS 304 STEEL	343
	I163	STAINLESS 304 STEEL	343
	MG	STAINLESS 316 STEEL	344
	KC-S	STAINLESS 316 STEEL	350
	KC-R	STAINLESS 316 STEEL	350
	EK-S	STAINLESS 316 STEEL	350
	EK-R	STAINLESS 316 STEEL	351
	SWP	STAINLESS 316 STEEL	351
	SWF	STAINLESS 316 STEEL	351
	XL-JS	STAINLESS 316 STEEL	352

	KB	STAINLESS 303 STEEL	354
	EC	STAINLESS 303 STEEL	354
	ECH	STAINLESS 303 STEEL	354
	DS	STAINLESS 303 STEEL	355
	DL	STAINLESS 303 STEEL	355
	XLA-HA		355
	SGH-200		357
	AM	ALUMINIUM	358
	KK-M	ALUMINIUM	358
	KK-H	ALUMINIUM	359
	PC		359
	H-42-B	STAINLESS 304 STEEL	360
	H-42-B-9	STAINLESS 304 STEEL	360
	H-42-F14	STAINLESS 316 STEEL	361
	H-42-C	STAINLESS 304 STEEL	361



Picture	Item Name		Page
	MG	<b>STAINLESS 304 STEEL</b>	361
	LF-12	<b>STAINLESS 304 STEEL</b>	362
	H-75-C	<b>STAINLESS 304 STEEL</b>	362
	H-75-BL-100	<b>STAINLESS 304 STEEL</b>	363
	AS-H30	<b>STAINLESS 304 STEEL</b>	363
	H42-Z	<b>STAINLESS 304 STEEL</b>	363

**HANDLES (Front Screw Mount)**

Picture	Item Name		Page
	2LC	<b>STAINLESS 316 STEEL</b>	344
	4LC	<b>STAINLESS 316 STEEL</b>	344
	3LC	<b>STAINLESS 304 STEEL</b> <b>STAINLESS 316 STEEL</b>	345
	XL-CUY	<b>STAINLESS 303 STEEL</b>	345
	EC-Y	<b>STAINLESS 303 STEEL</b>	345
	FT-120, 150	<b>STAINLESS 304 STEEL</b>	346
	FT-65, 80, 100	<b>STAINLESS 304 STEEL</b>	346
	FT-110S	<b>STAINLESS 304 STEEL</b>	346
	FT-S280, 370	<b>STAINLESS 316 STEEL</b>	347
	FT-200, 280	<b>STAINLESS 316 STEEL</b>	347
	EC-H	<b>STAINLESS 303 STEEL</b>	348
	US	<b>STAINLESS 303 STEEL</b>	348

Picture	Item Name	Page
	WB-130357, WB-902357	348
	WB-901790	349
	WB-900404, WB900405	349
	WB-901225	349

**SPECIALITY HANDLES**

Picture	Item Name		Page
	HK	<b>STAINLESS 304 STEEL</b>	356
	FK-S, FM-S	<b>STAINLESS 316 STEEL</b>	356
	MDH		357

RECESSED PULLS









Picture	Item Name		Page
	HH-M	STAINLESS 304 STEEL	364
	WB-901389		364
	ES-611	STAINLESS 304 STEEL	364
	HH-KS	STAINLESS 316 STEEL	365
	HH-DS	STAINLESS 316 STEEL	365
	HH-K	STAINLESS 316 STEEL	365
	HH-D	STAINLESS 316 STEEL	366
	HH-KL160	STAINLESS 304 STEEL	366
	HH-KP150	STAINLESS 304 STEEL	366
	HH-FB, HH-FC	STAINLESS 304 STEEL	367
	HH-AS2	STAINLESS 304 STEEL	367
	HH-AS3	STAINLESS 304 STEEL	367
	UTZ-130		368
	SD-160		368
	UT	STAINLESS 304 STEEL	368
	SP	STAINLESS 304 STEEL	369
	XLA-HH	ALUMINUM	369
	HH-QTR		370
	HH-P130		370
	HH-PS99		371
	WB-901390		371

Picture	Item Name	Center to Center	Page
	ATS-100		371
	AT-100		372
	AT-70		372
	YK-W100	STAINLESS 304 STEEL	372
	YK-70	STAINLESS 304 STEEL	372
	HN	STAINLESS 304 STEEL	373
	SMH	STAINLESS 304 STEEL	373
	OP-150	STAINLESS 304 STEEL	373







PULLS

Picture	Item Name		Page
	26700	STAINLESS 316 STEEL	374
	26900	STAINLESS 316 STEEL	374
	26901	STAINLESS 316 STEEL	374
	980641, 980642	STAINLESS 304 STEEL	375
	26700	STAINLESS 316 STEEL	375
	980640	STAINLESS 304 STEEL	375
	SND	STAINLESS 304 STEEL	381
	SN	STAINLESS 304 STEEL	381





**KNOBS**

Picture	Item Name		Page
	RSS	<b>STAINLESS 304 STEEL</b>	382
	RS-38	<b>STAINLESS 304 STEEL</b>	382
	EXCEL	<b>ALUMINIUM</b>	382
	KK-T	<b>ALUMINIUM</b>	383
	KK-B	<b>ALUMINIUM</b>	383
	SD	<b>STAINLESS 304 STEEL</b>	383
	AOT35	<b>ALUMINIUM</b>	384
	RD	<b>STAINLESS 316 STEEL</b>	384









**TRUNK HANDLES**

Picture	Item Name		Page
	HCT-150	<b>STAINLESS 316 STEEL</b>	376
	MUD-140		376
	TMU-115		377
	PT-148		377
	TO		378
	WB-901228		378

**HATCH PULLS**

Picture	Item Name		Page
	ST-90, 115	<b>STAINLESS 304 STEEL</b>	379
	ST-80, 100	<b>STAINLESS 304 STEEL</b>	379
	HR	<b>STAINLESS 304 STEEL</b>	380
	HR-R	<b>STAINLESS 304 STEEL</b>	380

**KNURLED KNOB**

Picture	Item Name		Page
	SRT	<b>STAINLESS 303 STEEL</b>	385
	SRT-N	<b>STAINLESS 303 STEEL</b>	385
	BRT-L6		385
	BRT		386
	BRT-NB		386
	BRT-NC		386
	BRB-A4-15CR, BRF		387
	DBN		387

## LARGE HANDLE



MP

- Ideal for harsh and high corrosion environments.
- Designed for machinery applications where a heavy duty handle is required.



### Installation

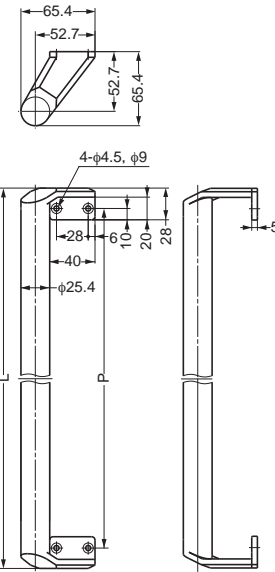
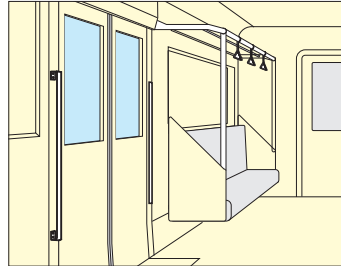

Item Code	Item Name	Material	Finish	L	P	Weight	Box	Carton
100-010-500	MP-500	Stainless Steel(SUS316)	Mirror	500	464	1000g	2pcs	20pcs
100-010-501	MP-750	Stainless Steel(SUS316)	Mirror	750	714	1300g	2pcs	16pcs
100-010-502	MP-1000	Stainless Steel(SUS316)	Mirror	1000	964	1600g	2pcs	12pcs

## LARGE HANDLE



SSH

- Ideal in high corrosion environments and machinery applications.
- Designed for applications where a heavy duty handle is required.
- Recommended screw size: M8x1.25.

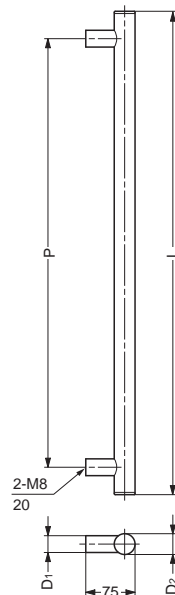

### Installation

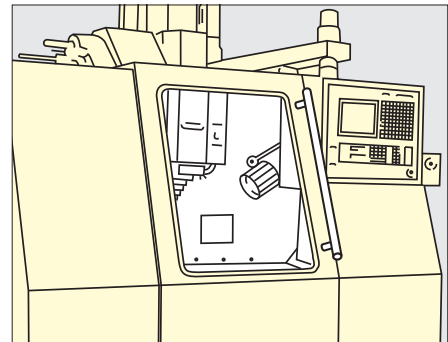

Item Code	Item Name	Material	Finish	L	P	D <sub>1</sub>	D <sub>2</sub>	Weight	Carton
100-181-413	SSH-2540	Stainless Steel(SUS304)	Satin	400	316	φ 19	φ 25	665g	10pcs
100-181-414	SSH-2560	Stainless Steel(SUS304)	Satin	600	516	φ 19	φ 25	750g	10pcs
100-181-415	SSH-2580	Stainless Steel(SUS304)	Satin	800	716	φ 19	φ 25	840g	10pcs
100-181-416	SSH-3240	Stainless Steel(SUS304)	Satin	400	316	φ 25	φ 32	1175g	5pcs
100-181-417	SSH-3260	Stainless Steel(SUS304)	Satin	600	516	φ 25	φ 32	1290g	5pcs
100-181-418	SSH-3280	Stainless Steel(SUS304)	Satin	800	716	φ 25	φ 32	1400g	5pcs

# LARGE HANDLE



# RH-760



- Low profile design.
- Designed for machinery applications where a heavy duty handle is required.

### Installation

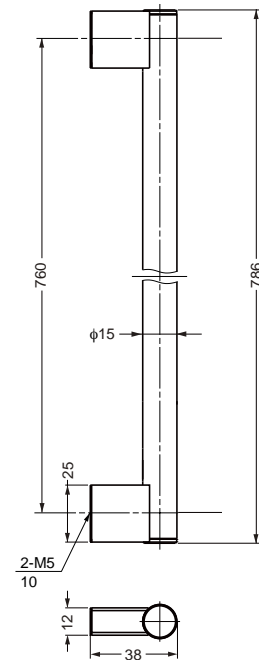
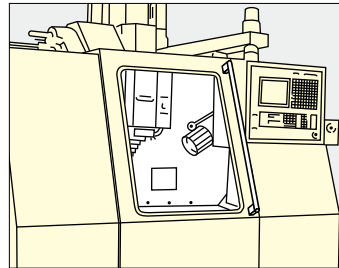

Item Code	Item Name	Material	Finish	Weight	Box
100-010-341	RH-760	Stainless Steel(SUS304)	Satin	340g	20pcs

# LARGE HANDLE



# SOR

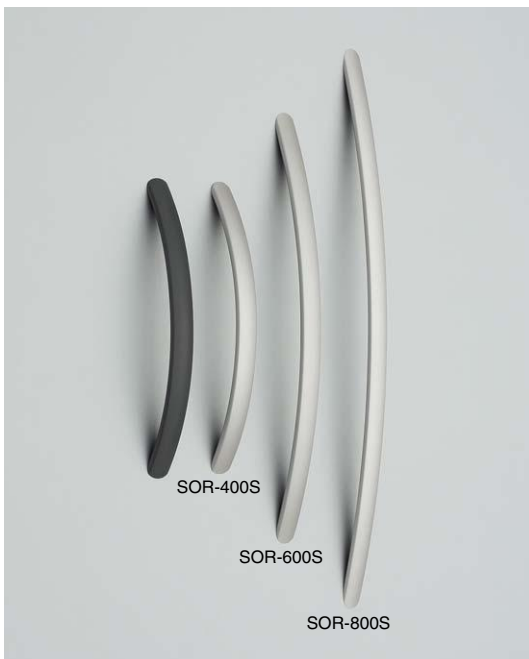

- Ideal for machinery applications where a large handle is required.

### Installation

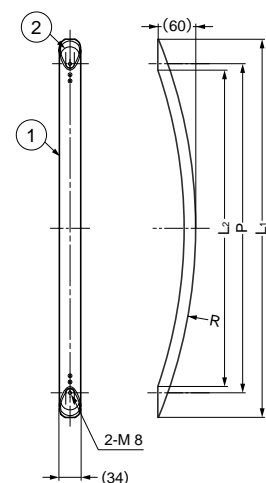
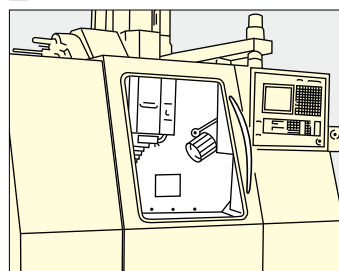

No.	Part Name	Material
①	Body	Aluminum Alloy
②	Insert	Stainless Steel(SCS13)

Item Code	Item Name	Finish	L <sub>1</sub>	L <sub>2</sub>	P	M	Weight	Carton
100-010-961	SOR-400S	Stainless Steel/Anodized	(390)	(323)	335	M6	385g	30pcs
100-010-963	SOR-400BL	Black/Anodized	(390)	(323)	335	M6	385g	30pcs
100-010-962	SOR-600S	Stainless Steel/Anodized	(600)	(502)	522	M6	495g	20pcs
100-010-964	SOR-600BL	Black/Anodized	(600)	(502)	522	M6	495g	20pcs
100-010-960	SOR-800S	Stainless Steel/Anodized	(816)	(686)	710	M8	605g	15pcs
100-010-965	SOR-800BL	Black/Anodized	(816)	(686)	710	M8	605g	15pcs

# HANDLE

STAINLESS  
304  
STEEL

I1014

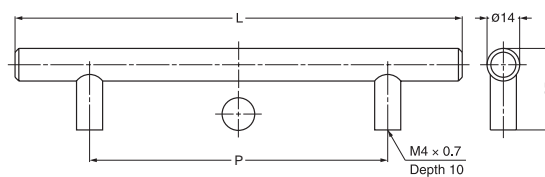

Item Code	Item Name	Material	Finish	L	P	Weight	Box
100-012-629	I1014128	Stainless Steel (SUS304)	Satin	192	128	113g	25pcs
100-012-628	I1014192	Stainless Steel (SUS304)	Satin	256	192	136g	25pcs
100-012-627	I1014342	Stainless Steel (SUS304)	Satin	406	342	187g	25pcs
100-012-626	I1014492	Stainless Steel (SUS304)	Satin	556	492	216g	25pcs

# HANDLE

STAINLESS  
304  
STEEL

I1020

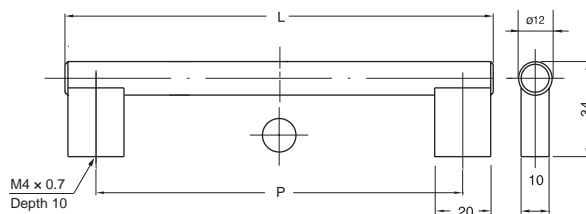

Item Code	Item Name	Material	Finish	L	P	Weight	Box
100-012-961	I1020128	Stainless Steel (SUS304)	Satin	150	128	159g	25pcs
100-012-962	I1020160	Stainless Steel (SUS304)	Satin	182	160	85g	25pcs
100-012-963	I1020192	Stainless Steel (SUS304)	Satin	214	192	93g	25pcs
100-012-964	I1020320	Stainless Steel (SUS304)	Satin	342	320	128g	25pcs
100-012-965	I1020492	Stainless Steel (SUS304)	Satin	514	492	175g	25pcs

# HANDLE

STAINLESS  
304  
STEEL

I333

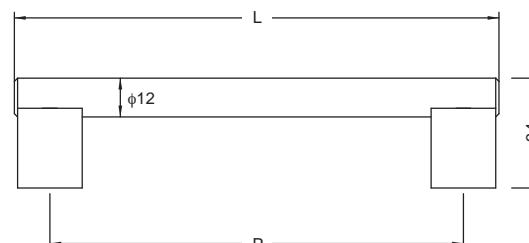

Item Code	Item Name	Material	Finish	L	P	Box
100-023-456	I333128	Stainless Steel (SUS304)	Satin	150	128	25pcs
100-023-457	I333160	Stainless Steel (SUS304)	Satin	182	160	25pcs
100-023-458	I333192	Stainless Steel (SUS304)	Satin	214	192	10pcs
100-023-459	I333292	Stainless Steel (SUS304)	Satin	314	292	10pcs
100-023-460	I333320	Stainless Steel (SUS304)	Satin	342	320	10pcs
100-023-461	I333342	Stainless Steel (SUS304)	Satin	364	342	10pcs



**HANDLE** STAINLESS 304 STEEL **I120**

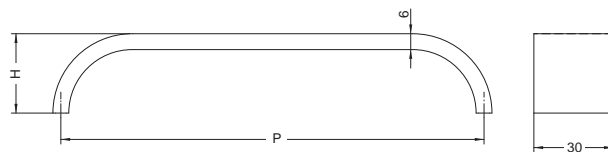

Item Code	Item Name	Material	Finish	P	H	Box
100-023-462	I120096	Stainless Steel (SUS304)	Satin	96	40	25pcs
100-023-463	I120128	Stainless Steel (SUS304)	Satin	128	40	25pcs
100-023-464	I120160	Stainless Steel (SUS304)	Satin	160	40	10pcs
100-023-465	I120192	Stainless Steel (SUS304)	Satin	192	40	10pcs
100-023-466	I120320	Stainless Steel (SUS304)	Satin	320	40	10pcs
100-023-467	I120512	Stainless Steel (SUS304)	Satin	512	40	10pcs

**HANDLE** STAINLESS 304 STEEL **I100**

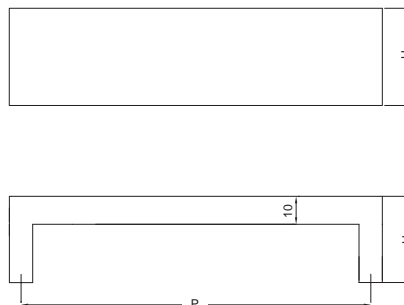
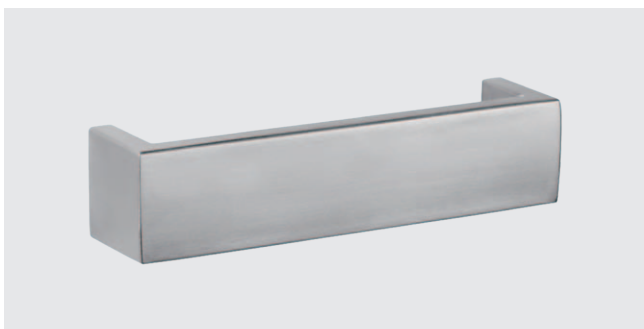

Item Code	Item Name	Material	Finish	P	H	Box
100-023-468	I100096	Stainless Steel (SUS304)	Satin	96	40	25pcs
100-023-469	I100128	Stainless Steel (SUS304)	Satin	128	40	25pcs
100-023-470	I100160	Stainless Steel (SUS304)	Satin	160	40	10pcs
100-023-471	I100192	Stainless Steel (SUS304)	Satin	192	40	10pcs
100-023-472	I100320	Stainless Steel (SUS304)	Satin	320	40	10pcs
100-023-473	I100512	Stainless Steel (SUS304)	Satin	512	40	10pcs

**HANDLE** STAINLESS 304 STEEL **I163**

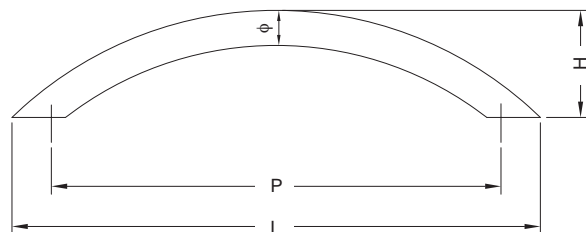

Item Code	Item Name	Material	Finish	L	P	H	Box
100-023-474	I163160	Stainless Steel (SUS304)	Satin	200	160	35	10pcs
100-023-475	I163192	Stainless Steel (SUS304)	Satin	244	192	35	10pcs
100-023-476	I163320	Stainless Steel (SUS304)	Satin	400	320	36	10pcs

# HANDLE



MG

- Ideal for harsh and high corrosion environments.
- Compliant with SEMI S8-0701 guideline.

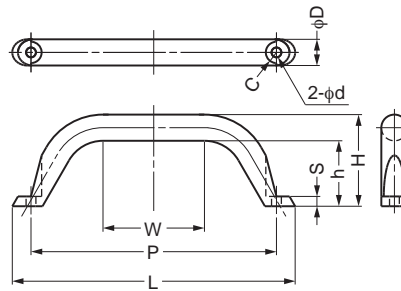

Item Code	Item Name	Material	Finish	D	C	L	P	W	H	h	S	d	Screw	Weight	Box	Carton
100-010-483	MG-150	Stainless Steel (SUS316)	Mirror	16	R6.5	(172.8)	150	62	(56)	40	6	6	M5	295g	10pcs	40pcs
100-010-484	MG-190	Stainless Steel (SUS316)	Mirror	18	R7.5	(216.7)	190	92	(63)	45	8	7	M6	460g	5pcs	20pcs
100-010-485	MG-250	Stainless Steel (SUS316)	Mirror	18	R7.5	(275.5)	250	145	(68)	50	8	7	M6	595g	5pcs	20pcs

# HANDLE



2LC

- Ideal for harsh and high corrosion environments.
- Stainless Steel handles are delivered with tapping screws. when using bolts, use size shown in table.

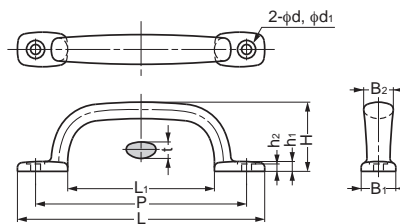

Item Code	Item Name	Material	Finish	L	L <sub>1</sub>	P	B <sub>1</sub>	B <sub>2</sub>	H	h <sub>1</sub>	h <sub>2</sub>	t	d	d <sub>1</sub>	Weight	Bolt	Box
100-010-131	2LC-80	Stainless Steel (SCS14)	Mirror	80	32	64	16	14	35	5.5	4	8	5	9.5	70g	M4	12pcs
100-010-132	2LC-120	Stainless Steel (SCS14)	Mirror	120	64	96	18	16	36	5.5	4.5	9	5	9.5	106g	M4	8pcs
100-010-133	2LC-150	Stainless Steel (SCS14)	Mirror	150	89	128	21	18	42	6	4.5	10	6	11	172g	M5	6pcs
100-010-134	2LC-180	Stainless Steel (SCS14)	Mirror	180	118	160	23	20	45	6.5	5	10	6	11	225g	M5	3pcs
100-010-355	2LC-80TI	Titanium	Shot Blast	80	32	64	16	14	35	5.5	4	8	5	9.5	37g	M4	20pcs
100-010-354	2LC-120TI	Titanium	Shot Blast	120	64	96	18	16	36	5.5	4.5	9	5	9.5	62g	M4	15pcs
100-010-353	2LC-150TI	Titanium	Shot Blast	150	89	128	21	18	42	6	4.5	10	6	11	96g	M5	10pcs

# HANDLE



4LC

- Ideal for harsh and high corrosion environments.
- Stainless Steel handles are delivered with tapping screws. when using bolts, use size shown in table.

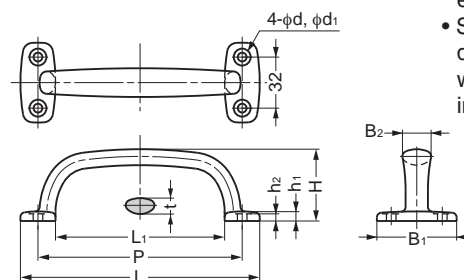

Item Code	Item Name	Material	Finish	L	L <sub>1</sub>	P	B <sub>1</sub>	B <sub>2</sub>	H	h <sub>1</sub>	h <sub>2</sub>	t	d	d <sub>1</sub>	Weight	Bolt	Box
100-010-135	4LC-82	Stainless Steel (SCS14)	Mirror	82	46	64	48	16	36.5	5.5	4	8	5	9.5	110g	M4	8pcs
100-010-136	4LC-114	Stainless Steel (SCS14)	Mirror	114	78	96	48	16	40	6	4.5	9	5	9.5	148g	M4	6pcs
100-010-137	4LC-150	Stainless Steel (SCS14)	Mirror	150	106	128	50	18	45	6	4.5	10	6	11	210g	M5	3pcs
100-010-138	4LC-180	Stainless Steel (SCS14)	Mirror	180	140	160	50	20	48	6.5	5	10	6	11	270g	M5	2pcs

# HANDLE



# 3LC

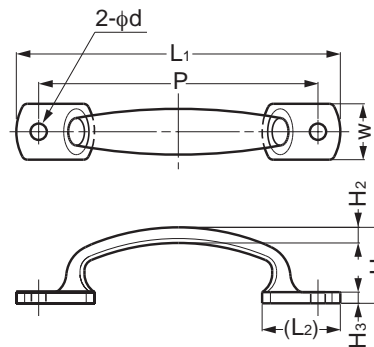

Item Code	Item Name	Material	Finish	L <sub>1</sub>	L <sub>2</sub>	W	H <sub>1</sub>	H <sub>2</sub>	H <sub>3</sub>	P	d	Weight	Box
100-019-846	3LC-120	Stainless Steel (SCS13)	Mirror	120	29	20	30	6	5	105	5.5	90g	100pcs
100-019-845	3LC-130	Stainless Steel (SCS13)	Mirror	130	30	22	33	7	6	115	5.5	120g	100pcs
100-019-747	3LC-145	Stainless Steel (SCS14)	Mirror	145	35	25	34	7	6	125	6.5	155g	80pcs

# HANDLE



# XL-CUY

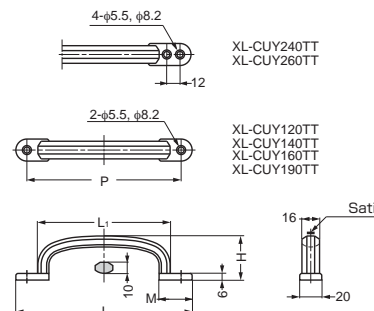

Item Code	Item Name	Material	Finish	L	L <sub>1</sub>	H	M	P	Weight	Box
100-012-834	XL-CUY120TT	Stainless Steel (SUS303)	Mirror and Satin Combination	118	80	36	30	100	148g	5pcs
100-012-835	XL-CUY140TT	Stainless Steel (SUS303)	Mirror and Satin Combination	138	100	38	30	120	171g	5pcs
100-012-836	XL-CUY160TT	Stainless Steel (SUS303)	Mirror and Satin Combination	158	120	40	30	140	195g	3pcs
100-012-837	XL-CUY190TT	Stainless Steel (SUS303)	Mirror and Satin Combination	188	150	42	30	170	228g	2pcs
100-012-838	XL-CUY240TT	Stainless Steel (SUS303)	Mirror and Satin Combination	238	180	44	40	196	278g	2pcs
100-012-839	XL-CUY260TT	Stainless Steel (SUS303)	Mirror and Satin Combination	258	200	46	40	216	301g	2pcs

# HANDLE



# EC-Y

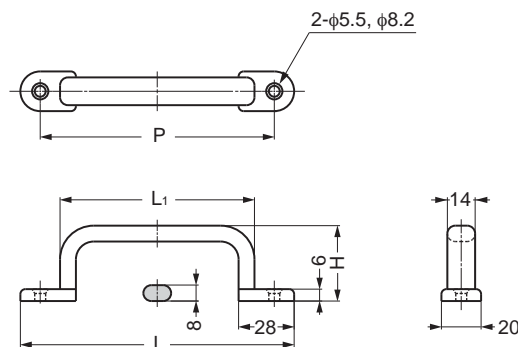

Item Code	Item Name	Material	Finish	L	L <sub>1</sub>	H	P	Weight	Box
100-012-831	EC-Y-140	Stainless Steel (SUS303)	Mirror	138	100	38	120	142g	5pcs
100-012-832	EC-Y-160	Stainless Steel (SUS303)	Mirror	158	120	40	140	160g	3pcs
100-012-833	EC-Y-190	Stainless Steel (SUS303)	Mirror	188	150	42	170	185g	2pcs

# HANDLE



FT-120,150

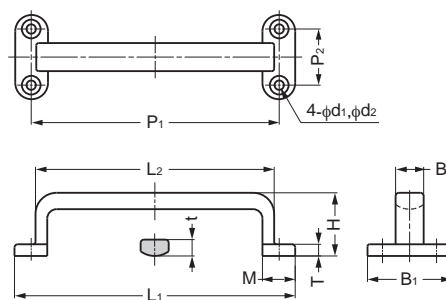

Item Code	Item Name	Material	Finish	L <sub>1</sub>	L <sub>2</sub>	B <sub>1</sub>	B <sub>2</sub>	H	T	t	M	P <sub>1</sub>	P <sub>2</sub>	d <sub>1</sub>	d <sub>2</sub>	Weight	Box	Carton
100-010-067	FT-120	Stainless Steel (SCS13)	Mirror	120	102	36	12	27	5	7	14	106	24	4.1	8	105g	10pcs	120pcs
100-010-068	FT-150	Stainless Steel (SCS13)	Mirror	150	129	45	15	33	6	8	18	132	30	5.3	10.4	191g	5pcs	40pcs

# HANDLE



FT-65,80,100

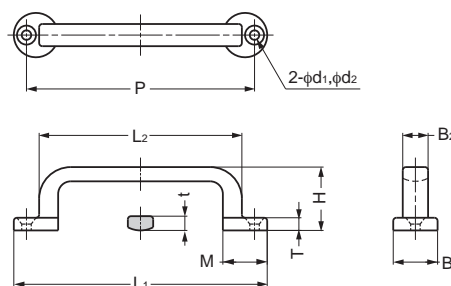

Item Code	Item Name	Material	Finish	L <sub>1</sub>	L <sub>2</sub>	B <sub>1</sub>	B <sub>2</sub>	H	T	t	M	P	d <sub>1</sub>	d <sub>2</sub>	Weight	Box	Carton
100-012-847	FT-65	Stainless Steel (SCS13)	Mirror	65	47	13	7	16	3.5	4	13	57	3.3	6.4	19g	40pcs	480pcs
100-012-848	FT-80	Stainless Steel (SCS13)	Mirror	80	61	14	8	20	4	4.5	14	72	3.3	6.4	32g	30pcs	360pcs
100-012-849	FT-100	Stainless Steel (SCS13)	Mirror	100	75	18	10	25	5	5.5	18	88	4.1	8	58g	20pcs	240pcs

# HANDLE



FT-110S

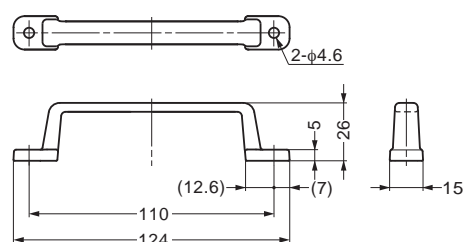

Item Code	Item Name	Material	Finish	Weight	Box	Carton
100-019-029	FT-110S	Stainless Steel (SCS13)	Satin	60g	50pcs	200pcs

# LARGE HANDLE



FT-S

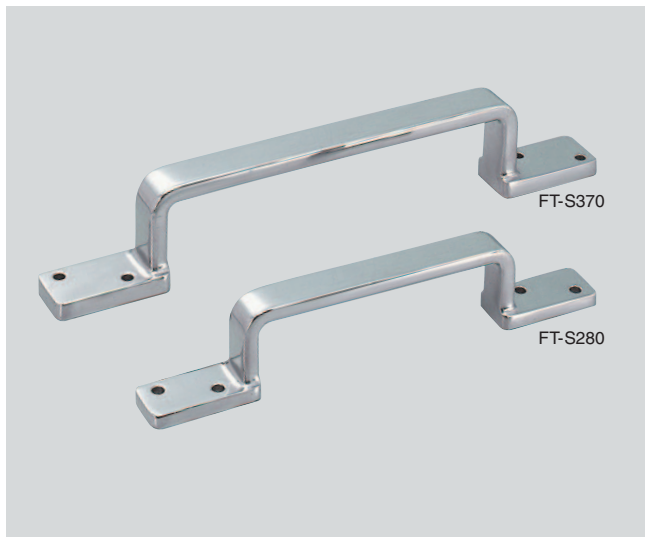

- Ideal for harsh and high corrosion environments.
- Higher profile allows for easy gripping with gloved hand.

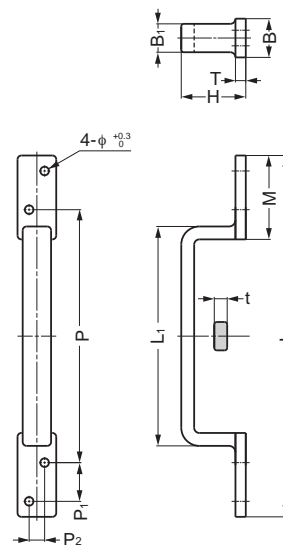

Item Code	Item Name	Material	Finish	L	L <sub>1</sub>	B	B <sub>1</sub>	H	T	t	M	P	P <sub>1</sub>	P <sub>2</sub>	Weight	Box	Carton
100-010-071	FT-S280	Stainless Steel (SCS14)	Mirror	280	170	30	22	50	8	10	65	196	30	12	612g	1pcs	20pcs
100-010-072	FT-S370	Stainless Steel (SCS14)	Mirror	370	250	36	26	62	10	12	72	277	35	18	1154g	1pcs	10pcs

# LARGE HANDLE



FT-200,280



- Ideal for harsh and high corrosion environments.
- Higher profile allows for easy gripping with gloved hand.

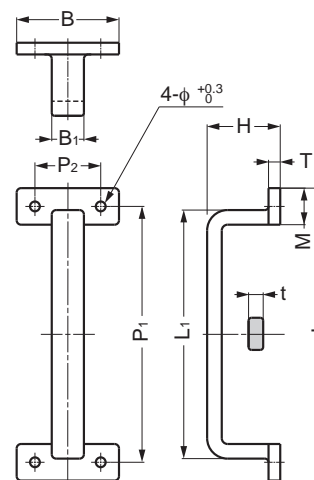

Item Code	Item Name	Material	Finish	L	L <sub>1</sub>	B	B <sub>1</sub>	H	T	t	M	P <sub>1</sub>	P <sub>2</sub>	Weight	Box	Carton
100-010-069	FT-200	Stainless Steel (SCS14)	Mirror	200	170	70	22	50	8	10	25	175	45	586g	1pcs	20pcs
100-010-070	FT-280	Stainless Steel (SCS14)	Mirror	280	250	80	26	62	10	12	27	253	55	1088g	1pcs	10pcs

# HANDLE



# EC-H

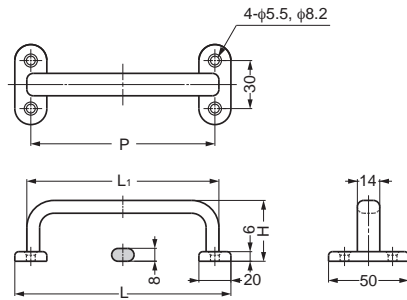

Item Code	Item Name	Material	Finish	L	L <sub>1</sub>	H	P	Weight	Box
100-010-056	EC-H-135	Stainless Steel (SUS303)	Mirror	135	120	40	115	191g	5pcs
100-010-057	EC-H-165	Stainless Steel (SUS303)	Mirror	165	150	42	145	216g	3pcs

# HANDLE



# US



- Rubber grip allows for an easy and comfortable grip.
- Light weight design.

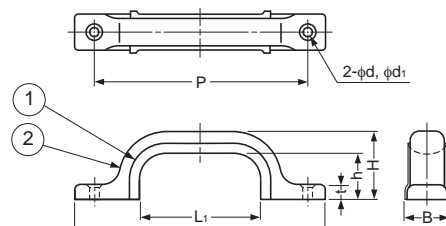

Item Code	Item Name	Finish	L	L <sub>1</sub>	P	B	H	h	t	d	d <sub>1</sub>	Weight	Screw	Box	Carton
100-012-243	US-70S	Satin	70	20	54	17	28	21	5.5	3.3	6.6	20g	3.1×16	20pcs	200pcs
100-012-240	US-70M	Mirror	70	20	54	17	28	21	5.5	3.3	6.6	20g	3.1×16	20pcs	200pcs
100-012-244	US-120S	Satin	120	57	102	19	32	21	6.5	3.8	7.6	45g	3.5×20	20pcs	200pcs
100-012-241	US-120M	Mirror	120	57	102	19	32	21	6.5	3.8	7.6	45g	3.5×20	20pcs	200pcs
100-012-245	US-160S	Satin	160	88	140	22	37.5	23	7.5	4.1	8.1	70g	4.1×25	10pcs	100pcs
100-012-242	US-160M	Mirror	160	88	140	22	37.5	23	7.5	4.1	8.1	70g	4.1×25	10pcs	100pcs

No.	Material	Finish
①	Synthetic Rubber	Black
②	Stainless Steel (SUS304)	Satin and Mirror Combination

# HANDLE

# WB-130357, WB-902357

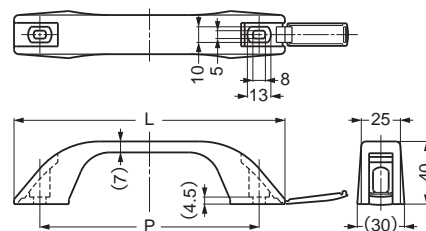

Item Code	Item Name	Material	Finish	L	P	Weight
100-012-911	WB-130357	Polypropylene	Black	173	140	38g
100-010-046	WB-902357	Polypropylene	Black	203	170	50g

# HANDLE

# WB-901790

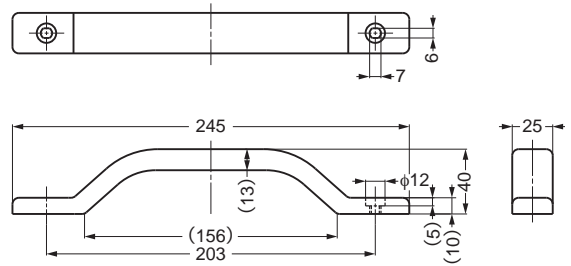

Item Code	Item Name	Material	Finish	Weight
100-012-919	WB-901790	Polypropylene	Black	54g

# HANDLE

# WB-900404, WB-900405

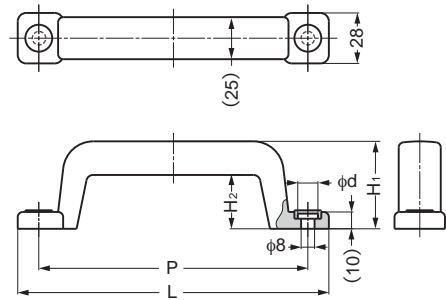

Item Code	Item Name	Material	Color	L	P	H <sub>1</sub>	H <sub>2</sub>	d	Weight
100-012-912	WB-900404	Polyurethane (Steel Core)	Black	188	160	52	32	15	152g
100-012-913	WB-900405	Polyurethane (Steel Core)	Black	275	253	55	40	18	266g

# HANDLE

# WB-901225

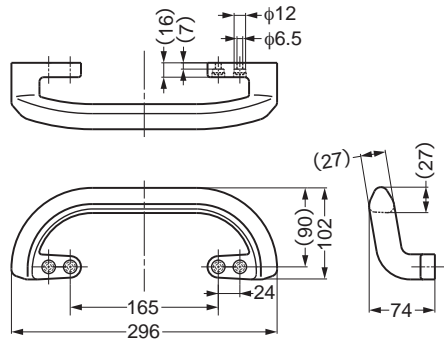

Item Code	Item Name	Material	Color	Weight
100-012-914	WB-901225	Polyurethane (Steel Core)	Black	400g

# HANDLE



## KC-S

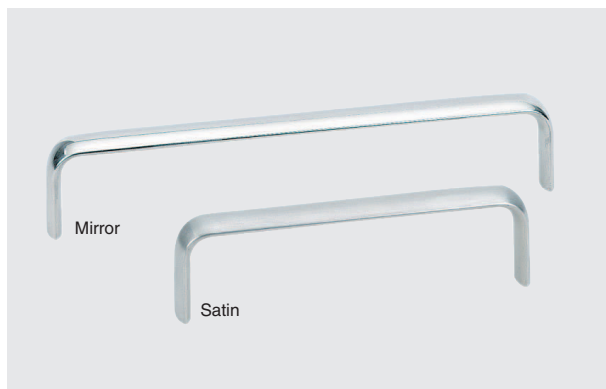

• Ideal for harsh and high corrosion environments.

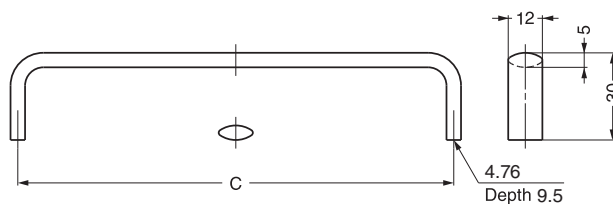

Item Code	Item Name	Item Code	Item Name	C	Weight	Box	Carton
100-023-410	KC-S635/M	100-023-414	KC-S635/S	88.9	67g	20pcs	200pcs
100-023-411	KC-S640/M	100-023-415	KC-S640/S	101.6	71g	20pcs	200pcs
100-023-412	KC-S650/M	100-023-416	KC-S650/S	127	85g	20pcs	200pcs
100-023-413	KC-S660/M	100-023-417	KC-S660/S	152.4	95g	20pcs	200pcs

Material	Finish
316 Stainless Steel	Mirror (M) Satin (S)

# HANDLE



## KC-R

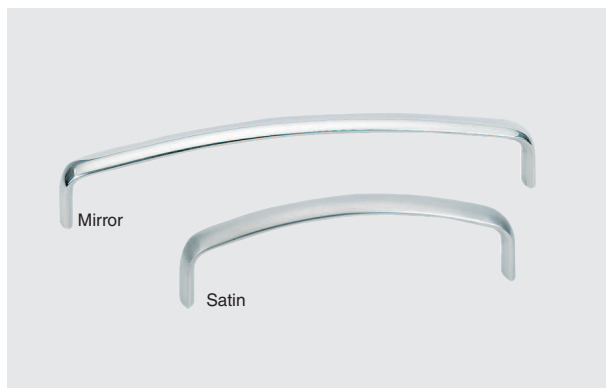

• Ideal for harsh and high corrosion environments.

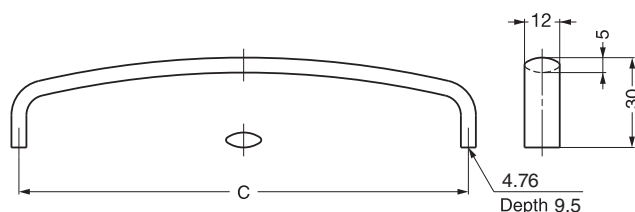

Item Code	Item Name	Item Code	Item Name	C	Weight	Box	Carton
100-023-418	KC-R635/M	100-023-422	KC-R635/S	88.9	60g	20pcs	200pcs
100-023-419	KC-R640/M	100-023-423	KC-R640/S	101.6	67g	20pcs	200pcs
100-023-420	KC-R650/M	100-023-424	KC-R650/S	127	78g	20pcs	200pcs
100-023-421	KC-R660/M	100-023-425	KC-R660/S	152.4	88g	20pcs	200pcs

Material	Finish
316 Stainless Steel	Mirror (M) Satin (S)

# HANDLE



## EK-S

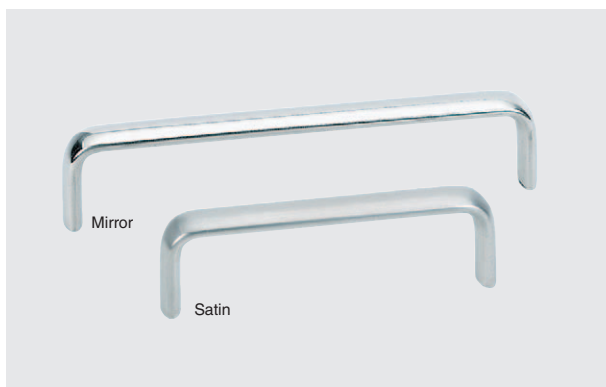

• Ideal for harsh and high corrosion environments.

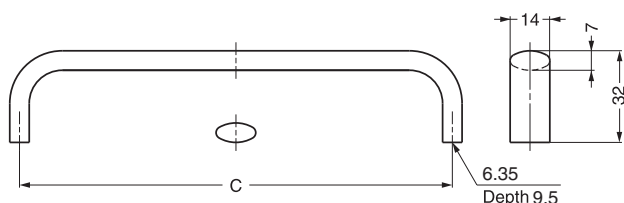

Item Code	Item Name	Item Code	Item Name	C	Weight	Box	Carton
100-023-426	EK-S635/M	100-023-430	EK-S635/S	88.9	106g	20pcs	200pcs
100-023-427	EK-S640/M	100-023-431	EK-S640/S	101.6	116g	20pcs	200pcs
100-023-428	EK-S650/M	100-023-432	EK-S650/S	127	134g	20pcs	200pcs
100-023-429	EK-S660/M	100-023-433	EK-S660/S	152.4	152g	20pcs	200pcs

Material	Finish
316 Stainless Steel	Mirror (M) Satin (S)



# HANDLE



# EK-R

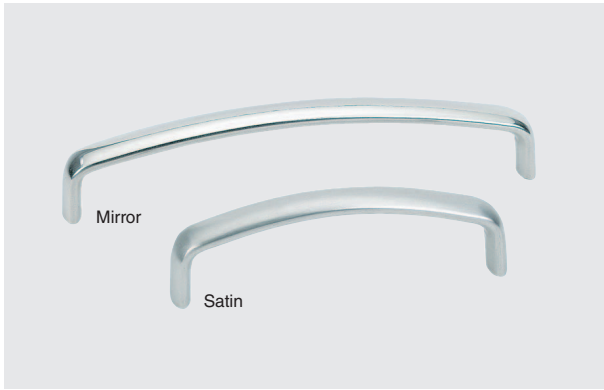

• Ideal for harsh and high corrosion environments.

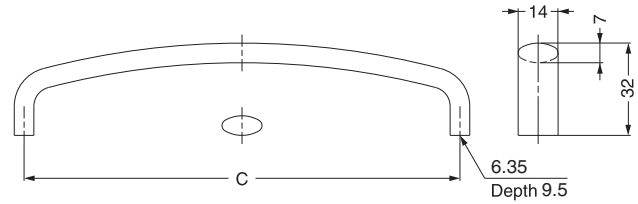

Item Code	Item Name	Item Code	Item Name	C	Weight	Box	Carton
100-010-460	EK-R635/M	100-010-464	EK-R635/S	88.9	95g	20pcs	200pcs
100-010-461	EK-R640/M	100-010-465	EK-R640/S	101.6	106g	20pcs	200pcs
100-010-462	EK-R650/M	100-010-466	EK-R650/S	127	123g	20pcs	200pcs
100-010-463	EK-R660/M	100-010-467	EK-R660/S	152.4	141g	20pcs	200pcs

Material	Finish
316 Stainless Steel	Mirror (M) Satin (S)

# WIRE PULL



# SWP



• Ideal for harsh and high corrosion environments.

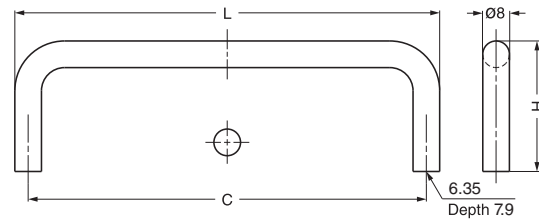

Item Code	Item Name	L	C	H	Weight	Box	Carton
100-023-434	SWP-630/S	84.2	76.2	34	71g	20pcs	200pcs
100-023-435	SWP-635/S	96.9	88.9	34	78g	20pcs	200pcs
100-023-436	SWP-640/S	109.6	101.6	34	85g	20pcs	200pcs
100-023-437	SWP-696/S	104	96	34	91g	20pcs	200pcs

Material	Finish
316 Stainless Steel	Satin

# WIRE PULL



# SWF

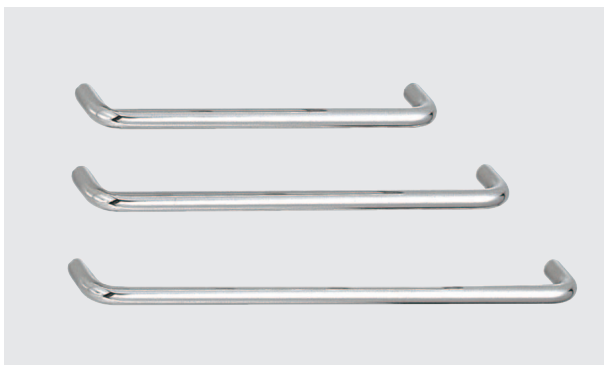

• Ideal for harsh and high corrosion environments.

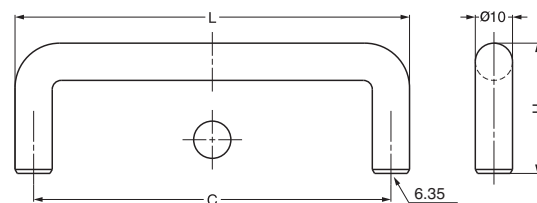

Item Code	Item Name	L	C	H	Weight	Box	Carton
100-023-438	SWF-640	111	101.5	35	90g	20pcs	200pcs
100-023-439	SWF-650	136.5	127	35	110g	20pcs	200pcs
100-023-440	SWF-660	162	152.5	35	130g	20pcs	200pcs
100-023-441	SWF-690	238	228.5	35	200g	20pcs	200pcs
100-023-442	SWF-6120	314.5	305	35	270g	20pcs	200pcs

Material	Finish
316 Stainless Steel	Satin

# HANDLE



## XL-JS



• Ideal for harsh and high corrosion environments.

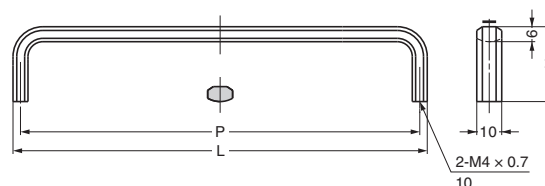

Item Code	Item Name	Material	Finish	L	P	H	Weight	Box	Carton
100-012-792	XL-JS165TT	Stainless Steel (SUS316)	Mirror and Satin Combination	166	160	30	81g	15pcs	150pcs
100-012-793	XL-JS260TT	Stainless Steel (SUS316)	Mirror and Satin Combination	260	254	33	122g	10pcs	100pcs
100-012-794	XL-JS360TT	Stainless Steel (SUS316)	Mirror and Satin Combination	358	352	36	166g	10pcs	100pcs

# HANDLE



## XL-JSR



• Ideal for harsh and high corrosion environments.

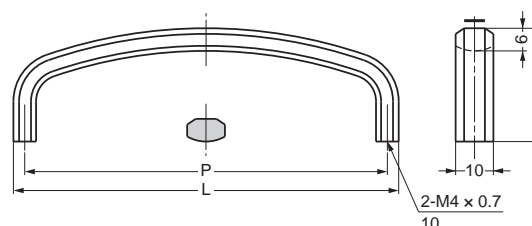

Item Code	Item Name	Material	Finish	L	P	H	Weight	Box	Carton
100-012-795	XL-JSR40TT	Stainless Steel (SUS316)	Mirror and Satin Combination	38	32	27	26g	30pcs	300pcs
100-012-796	XL-JSR70TT	Stainless Steel (SUS316)	Mirror and Satin Combination	70	64	30	35g	20pcs	200pcs
100-012-797	XL-JSR100TT	Stainless Steel (SUS316)	Mirror and Satin Combination	102	96	30	51g	20pcs	200pcs
100-012-798	XL-JSR135TT	Stainless Steel (SUS316)	Mirror and Satin Combination	134	128	30	63g	15pcs	150pcs

# HANDLE



## XL-CU

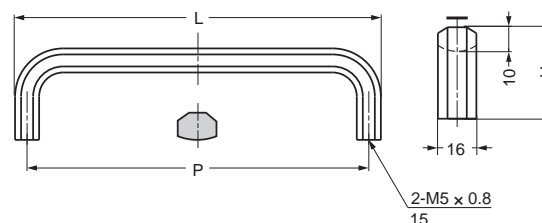

Item Code	Item Name	Material	Finish	L	H	P	Weight	Box	Carton
100-010-470	XL-CU80TT	Stainless Steel (SUS303)	Mirror and Satin Combination	82	32	72	112g	10pcs	100pcs
100-010-471	XL-CU100TT	Stainless Steel (SUS303)	Mirror and Satin Combination	102	34	92	136g	10pcs	100pcs
100-010-472	XL-CU120TT	Stainless Steel (SUS303)	Mirror and Satin Combination	122	36	112	163g	10pcs	100pcs
100-010-473	XL-CU150TT	Stainless Steel (SUS303)	Mirror and Satin Combination	152	38	142	200g	8pcs	80pcs
100-010-474	XL-CU180TT	Stainless Steel (SUS303)	Mirror and Satin Combination	182	40	172	234g	8pcs	80pcs
100-010-475	XL-CU220TT	Stainless Steel (SUS303)	Mirror and Satin Combination	222	42	212	282g	8pcs	40pcs
100-010-476	XL-CU300TT	Stainless Steel (SUS303)	Mirror and Satin Combination	302	44	292	372g	6pcs	30pcs

# HANDLE



# XL-CUR

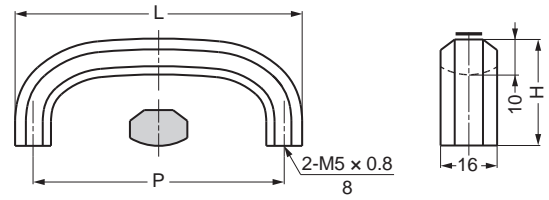

Item Code	Item Name	Material	Finish	L	H	P	Weight	Box
100-012-825	XL-CUR80TT	Stainless Steel (SUS303)	Mirror and Satin Combination	80	30	70	101g	10pcs
100-012-826	XL-CUR100TT	Stainless Steel (SUS303)	Mirror and Satin Combination	100	32	90	125g	10pcs
100-012-827	XL-CUR120TT	Stainless Steel (SUS303)	Mirror and Satin Combination	120	34	110	150g	10pcs
100-012-828	XL-CUR150TT	Stainless Steel (SUS303)	Mirror and Satin Combination	150	36	140	183g	5pcs

# HANDLE



# FB

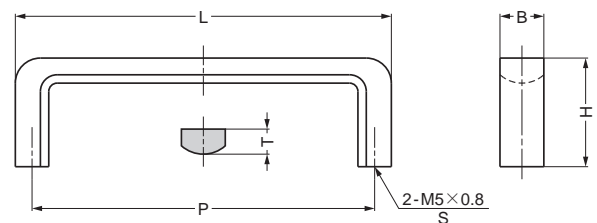

Item Code	Item Name	Material	Finish	L	H	B	T	P	S	Weight	Box	Carton
100-010-074	FB-90	Stainless Steel (SCS13)	Mirror	90	26	10.5	6	82	10	45g	35pcs	280pcs
100-010-075	FB-110	Stainless Steel (SCS13)	Mirror	110	28	12.5	7	102	12	60g	25pcs	200pcs
100-010-076	FB-130	Stainless Steel (SCS13)	Mirror	130	32	14.5	8	120	14	93g	20pcs	160pcs

※ SCS13 is equivalent to SUS304.

# HANDLE



# KPH

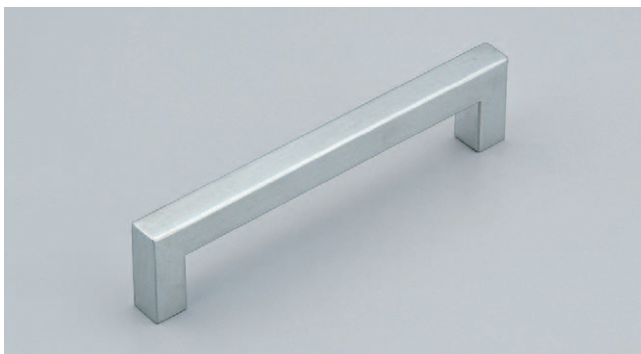

• Ideal for light weight applications.

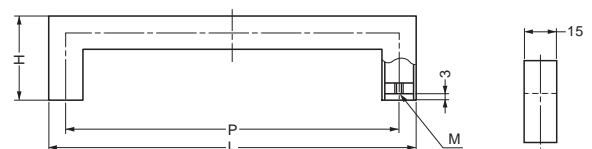

Item Code	Item Name	Material	Finish	L	P	H	M	Weight	Box	Carton
100-019-195	KPH-160	Stainless Steel (SUS304)	Satin	176	160	40	M4x0.7	100g	10pcs	100pcs
100-019-196	KPH-192	Stainless Steel (SUS304)	Satin	208	192	40	M4x0.7	115g	10pcs	100pcs
100-019-197	KPH-224	Stainless Steel (SUS304)	Satin	240	224	50	M5x0.8	130g	10pcs	100pcs
100-019-198	KPH-256	Stainless Steel (SUS304)	Satin	272	256	50	M5x0.8	143g	10pcs	100pcs
100-019-199	KPH-288	Stainless Steel (SUS304)	Satin	304	288	50	M5x0.8	160g	10pcs	100pcs

# HANDLE



**KB**

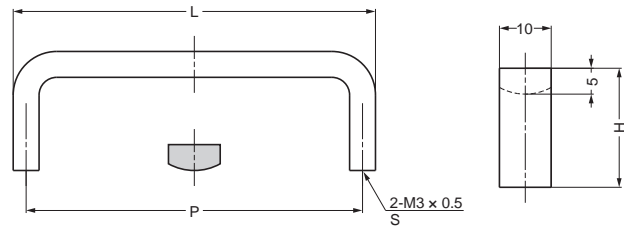
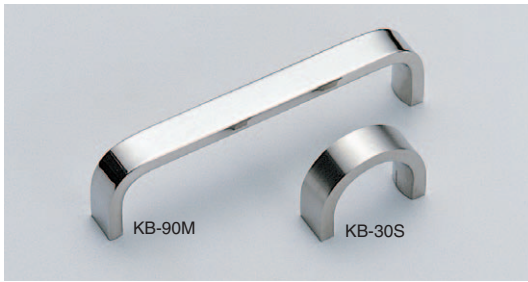

Item Code	Item Name	Material	Finish	L	H	P	S	Weight	Box	Carton
100-011-094	KB-30S	Stainless Steel (SUS303)	Satin	30	23	25	8	18g	40pcs	400pcs
100-011-093	KB-30M	Stainless Steel (SUS303)	Mirror	30	23	25	8	18g	40pcs	400pcs
100-011-096	KB-50S	Stainless Steel (SUS303)	Satin	50	22	45	10	26g	30pcs	300pcs
100-011-095	KB-50M	Stainless Steel (SUS303)	Mirror	50	22	45	10	26g	30pcs	300pcs
100-011-098	KB-70S	Stainless Steel (SUS303)	Satin	70	22.5	65	10	33g	30pcs	300pcs
100-011-097	KB-70M	Stainless Steel (SUS303)	Mirror	70	22.5	65	10	33g	30pcs	300pcs
100-011-100	KB-90S	Stainless Steel (SUS303)	Satin	90	23	85	10	40g	20pcs	200pcs
100-011-099	KB-90M	Stainless Steel (SUS303)	Mirror	90	23	85	10	40g	20pcs	200pcs

# HANDLE



**EC**

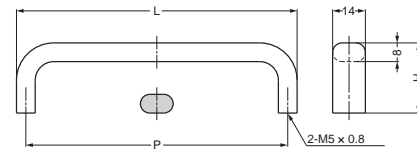

Item Code	Item Name	Material	Finish	L	H	P	S	Weight	Box	Carton
100-017-232	EC-80S	Stainless Steel (SUS304)	Satin	80	30	72	10	84g	20pcs	200pcs
100-017-226	EC-80M	Stainless Steel (SUS304)	Mirror	80	30	72	10	84g	20pcs	200pcs
100-017-233	EC-100S	Stainless Steel (SUS304)	Satin	100	32	92	10	102g	15pcs	150pcs
100-017-227	EC-100M	Stainless Steel (SUS304)	Mirror	100	32	92	10	102g	15pcs	150pcs
100-017-234	EC-120S	Stainless Steel (SUS304)	Satin	120	34	112	12	120g	15pcs	150pcs
100-017-228	EC-120M	Stainless Steel (SUS304)	Mirror	120	34	112	12	120g	15pcs	150pcs
100-017-235	EC-150S	Stainless Steel (SUS304)	Satin	150	36	142	12	148g	10pcs	100pcs
100-017-229	EC-150M	Stainless Steel (SUS304)	Mirror	150	36	142	12	148g	10pcs	100pcs
100-017-236	EC-180S	Stainless Steel (SUS304)	Satin	180	37	172	12	174g	10pcs	100pcs
100-010-049	EC-180M	Stainless Steel (SUS304)	Mirror	180	37	172	12	174g	10pcs	100pcs
100-017-237	EC-220S	Stainless Steel (SUS304)	Satin	220	38	212	12	205g	8pcs	80pcs
100-010-050	EC-220M	Stainless Steel (SUS304)	Mirror	220	38	212	12	205g	8pcs	80pcs

# HANDLE



**ECH**

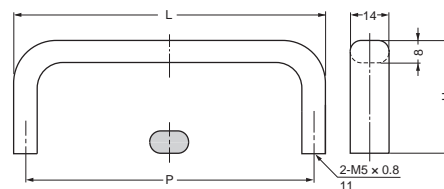

Item Code	Item Name	Material	Finish	L	H	P	Weight	Box	Carton
100-017-249	ECH-75S	Stainless Steel (SUS303)	Satin	83	40	75	115g	10pcs	100pcs
100-017-241	ECH-75M	Stainless Steel (SUS303)	Mirror	83	40	75	115g	10pcs	100pcs
100-017-252	ECH-100S	Stainless Steel (SUS303)	Satin	108	40	100	135g	15pcs	150pcs
100-017-242	ECH-100M	Stainless Steel (SUS303)	Mirror	108	40	100	135g	15pcs	150pcs
100-017-251	ECH-125S	Stainless Steel (SUS303)	Satin	133	40	125	153g	10pcs	100pcs
100-017-243	ECH-125M	Stainless Steel (SUS303)	Mirror	133	40	125	153g	10pcs	100pcs
100-017-244	ECH-150M	Stainless Steel (SUS303)	Mirror	158	50	150	190g	7pcs	70pcs
100-017-245	ECH-200M	Stainless Steel (SUS303)	Mirror	208	50	200	244g	10pcs	100pcs
100-017-246	ECH-250M	Stainless Steel (SUS303)	Mirror	258	50	250	280g	5pcs	50pcs
100-017-247	ECH-300M	Stainless Steel (SUS303)	Mirror	308	50	300	306g	5pcs	50pcs

# HANDLE



# DS

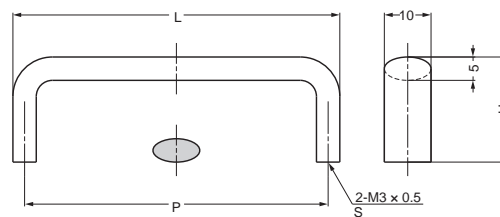

Item Code	Item Name	Material	Finish	L	H	P	S	Weight	Box	Carton
100-011-112	DS-30S	Stainless Steel (SUS303)	Satin	30	23	25	8	15g	40pcs	400pcs
100-011-111	DS-30M	Stainless Steel (SUS303)	Mirror	30	23	25	8	15g	40pcs	400pcs
100-011-114	DS-50S	Stainless Steel (SUS303)	Satin	50	22	45	10	22g	30pcs	300pcs
100-011-113	DS-50M	Stainless Steel (SUS303)	Mirror	50	22	45	10	22g	30pcs	300pcs
100-011-116	DS-70S	Stainless Steel (SUS303)	Satin	70	22.5	65	10	28g	30pcs	300pcs
100-011-115	DS-70M	Stainless Steel (SUS303)	Mirror	70	22.5	65	10	28g	30pcs	300pcs
100-011-118	DS-90S	Stainless Steel (SUS303)	Satin	90	23	85	10	35g	20pcs	200pcs
100-011-117	DS-90M	Stainless Steel (SUS303)	Mirror	90	23	85	10	35g	20pcs	200pcs

# HANDLE



# DL

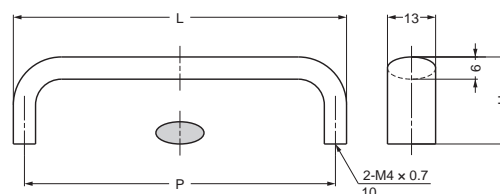

Item Code	Item Name	Material	Finish	L	H	P	Weight	Box	Carton
100-011-102	DL-70S	Stainless Steel (SUS303)	Satin	70	23	64	44g	20pcs	200pcs
100-011-101	DL-70M	Stainless Steel (SUS303)	Mirror	70	23	64	44g	20pcs	200pcs
100-011-104	DL-90S	Stainless Steel (SUS303)	Satin	90	23.5	84	55g	20pcs	200pcs
100-011-103	DL-90M	Stainless Steel (SUS303)	Mirror	90	23.5	84	55g	20pcs	200pcs
100-011-106	DL-110S	Stainless Steel (SUS303)	Satin	110	24	104	65g	15pcs	150pcs
100-011-105	DL-110M	Stainless Steel (SUS303)	Mirror	110	24	104	65g	15pcs	150pcs
100-011-108	DL-130S	Stainless Steel (SUS303)	Satin	130	24.5	124	75g	15pcs	150pcs
100-011-107	DL-130M	Stainless Steel (SUS303)	Mirror	130	24.5	124	75g	15pcs	150pcs
100-011-110	DL-150S	Stainless Steel (SUS303)	Satin	150	25	144	86g	15pcs	150pcs
100-011-109	DL-150M	Stainless Steel (SUS303)	Mirror	150	25	144	86g	15pcs	150pcs

# HANDLE



# XLA-HA

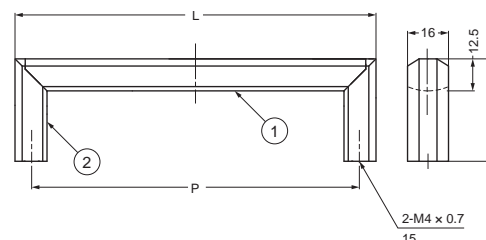

No.	Part Name	Material	Finish
①	Handle	Aluminum Alloy	Anodized
②	Leg	Zinc Alloy	Matte Silver

Item Code	Item Name	L	P	Weight	Box	Carton
100-010-059	XLA-HA96	109	96	120g	20pcs	80pcs
100-010-060	XLA-HA128	141	128	130g	20pcs	80pcs
100-010-061	XLA-HA192	205	192	145g	20pcs	80pcs
100-010-062	XLA-HA256	269	256	160g	10pcs	60pcs
100-010-063	XLA-HA320	333	320	175g	10pcs	60pcs

# FOLDING HANDLE



HK



- 90-degree folding handle.
- Handle clicks into open and closed position.

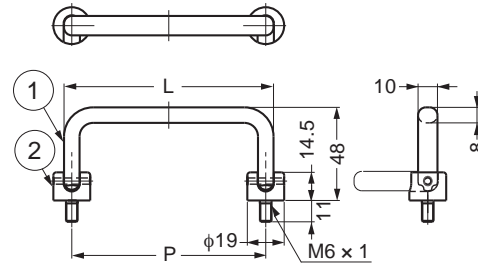

No.	Material	Finish
①	Stainless Steel (SUS304)	Mirror
②		

Item Code	Item Name	P	L	Load Capacity		Weight	Box	Carton
100-010-011	HK-80	80	88	490N	50kgf	125g	10pcs	100pcs
100-010-012	HK-100	100	108	490N	50kgf	136g	10pcs	100pcs
100-010-013	HK-120	120	128	490N	50kgf	146g	10pcs	100pcs

# PITCH ADJUSTABLE HANDLE



FK-S, FM-S

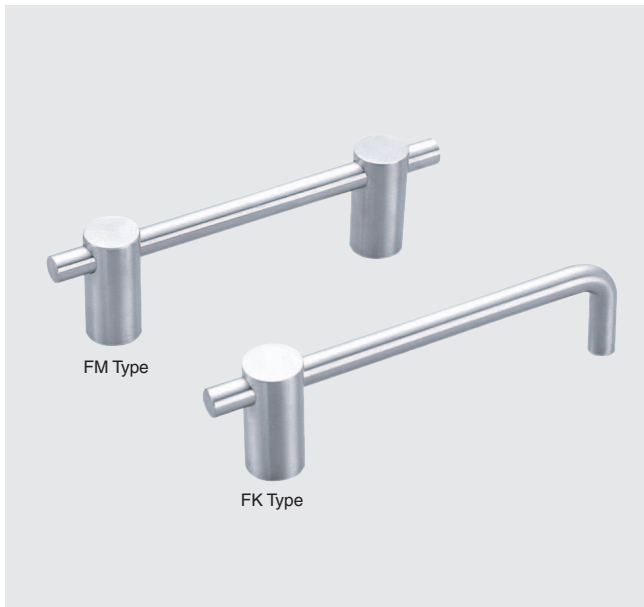

- Pitch adjustable feature to fit prefixed mounting holes.

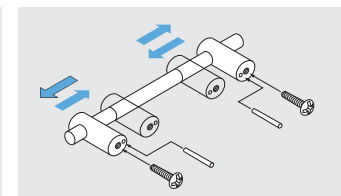
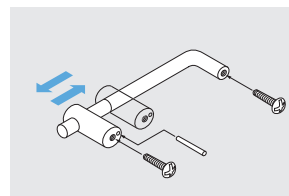
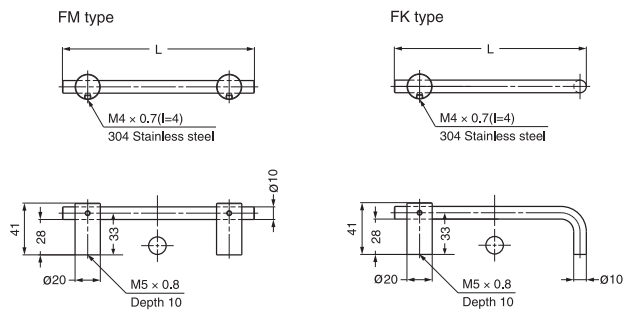

Item Code	Item Name	L	Weight	Box	Carton
100-019-647	FK-S150	152	193g	10pcs	100pcs
100-019-648	FK-S250	254	250g	10pcs	100pcs
100-019-649	FK-S380	381	335g	10pcs	100pcs
100-019-650	FK-S510	508	414g	10pcs	100pcs
100-019-651	FM-S150	152	265g	10pcs	100pcs
100-019-652	FM-S250	254	332g	10pcs	100pcs
100-019-653	FM-S380	381	407g	10pcs	100pcs
100-019-654	FM-S510	508	489g	10pcs	100pcs

Material	Finish
316 Stainless Steel	Satin

HANDLE



MDH



Bracket



- Bracket and pipe are sold separately
- M8×15 Bolt in Option

MDH-BS Bracket and pipe combination

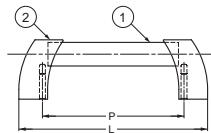

MDH-BF Bracket and pipe combination

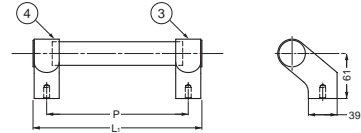

Bracket

Item Code	Item Name	Material	Finish	Weight
100-022-158	MDH-BS	Zinc Alloy (ZDC)	Chrome	1010g
100-022-159	MDH-BFR	Zinc Alloy (ZDC)	Chrome	1122g

Pipe

Item Code	Item Name	Material	Finish	Pipe Length	L	L <sub>1</sub>	P	Weight
100-022-161	MDH-PS192	Stainless Steel (SUS304)	Satin	177	256	226	192	384g
100-022-162	MDH-PS350	Stainless Steel (SUS304)	Satin	335	414	384	350	727g
100-022-163	MDH-PS500	Stainless Steel (SUS304)	Satin	485	564	534	500	1050g
100-022-164	MDH-PS800	Stainless Steel (SUS304)	Satin	785	864	834	800	1700g
100-022-165	MDH-PS1200	Stainless Steel (SUS304)	Satin	1185	1264	1234	1200	2570g
100-022-166	MDH-PC192	Carbon (CFRP)	Clear	177	256	226	192	70g
100-022-167	MDH-PC350	Carbon (CFRP)	Clear	335	414	384	350	132g
100-022-168	MDH-PC500	Carbon (CFRP)	Clear	485	564	534	500	191g
100-022-169	MDH-PC800	Carbon (CFRP)	Clear	785	864	834	800	309g
100-022-170	MDH-PC1200	Carbon (CFRP)	Clear	1185	1264	1234	1200	467g

HANDLE



SGH-200



- 9SGH-200 is a specially insulated handle designed to reduce shock from static electricity build-up as well as inhibit bacterial transfer.
- Textured, soft handle improves grip in manufacturing environments where lubricants are used, improving conditions when slippage is a safety concern.
- Un-obtrusive light blue color.
- Suitable for use in environments -22°F to 176°F (-30°C to 80°C).
- For use in medical, pharmaceutical, and electronic equipment; for use in educational, institutional, and industrial facilities where limiting transfer of static electricity or bacteria is important to operations.

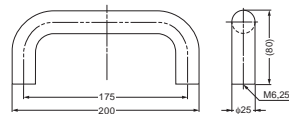

Pathway of releasing Electrical Discharge

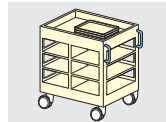
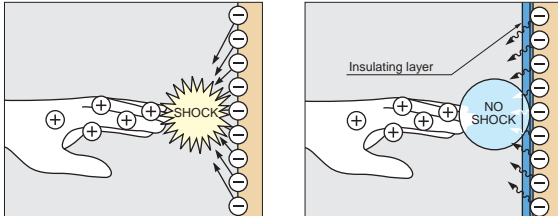

Properties of special Elastomer Coating

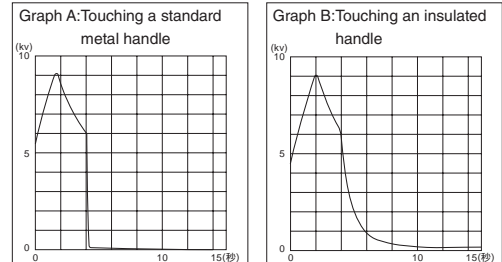

Properties of Special Elastomer Coating

- The y-axis represents the natural voltage of the human body (in kiloVolts), and the x-axis represents elapsed time (in seconds). Contact with the hardware occurs at the 4 second mark.
- There is an instantaneous discharge to 0kV in Graph A, compared to a delayed discharge to 1kV over 2 seconds in Graph B. This would result in a stronger electric discharge and shock for a metal handle (Graph A) compared to the SGH-200 (Graph B).

Pathway of Releasing Electrical Discharge

- In the figures above, a human hand with a positive charge is approaching a conductive surface with a negative charge (e.g., metal). The figure on the right incorporates a layer to insulate the discharge.
- Direct physical contact with a conductive surface (metal, etc.) may result in a discharge of static electricity, causing discomfort. The insulating coating of the SGH-200 acts as a buffer to reduce the rate of discharge and lessen the resulting shock (depicted above). The elastomer used for insulation incorporates a resin specially formulated for a specific conductivity.

Item Code	Item Name	Material	Color	Weight	Box	Carton
100-013-022	SGH-200	Base Material: Polyamide, Coating : Elastomer	Blue	250g	1pcs	20pcs

# HANDLE



AM

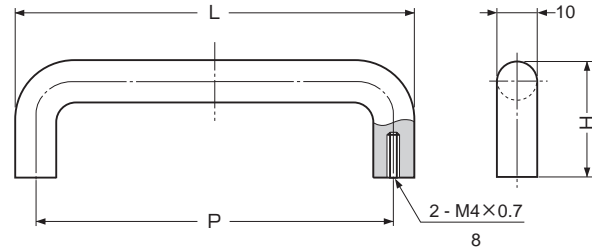

Item Code	Item Name	Material	Finish/Color	L	H	P	Weight	Box
100-017-600	AM-60I	Aluminum Alloy	Paint/Ivory	60	29	50	15.8g	30pcs
100-017-603	AM-80I	Aluminum Alloy	Paint/Ivory	80	29	70	19.8g	30pcs
100-017-606	AM-100I	Aluminum Alloy	Paint/Ivory	100	29	90	23.4g	30pcs
100-017-609	AM-120I	Aluminum Alloy	Paint/Ivory	120	29	110	26.8g	30pcs
100-017-612	AM-310I	Aluminum Alloy	Paint/Ivory	310	38	300	67g	10pcs
100-017-601	AM-60B	Aluminum Alloy	Paint/Black	60	29	50	15.8g	30pcs
100-017-604	AM-80B	Aluminum Alloy	Paint/Black	80	29	70	19.8g	30pcs
100-017-607	AM-100B	Aluminum Alloy	Paint/Black	100	29	90	23.4g	30pcs
100-017-610	AM-120B	Aluminum Alloy	Paint/Black	120	29	110	26.8g	30pcs
100-900-593	AM-310B	Aluminum Alloy	Paint/Black	310	38	300	67g	10pcs
100-017-602	AM-60S	Aluminum Alloy	Anodized/Silver	60	29	50	15.8g	30pcs
100-017-605	AM-80S	Aluminum Alloy	Anodized/Silver	80	29	70	19.8g	30pcs
100-017-608	AM-100S	Aluminum Alloy	Anodized/Silver	100	29	90	23.4g	30pcs
100-017-611	AM-120S	Aluminum Alloy	Anodized/Silver	120	29	110	26.8g	30pcs
100-017-614	AM-310S	Aluminum Alloy	Anodized/Silver	310	38	300	67g	10pcs

# HANDLE



KK-M



• Antibacterial coating.

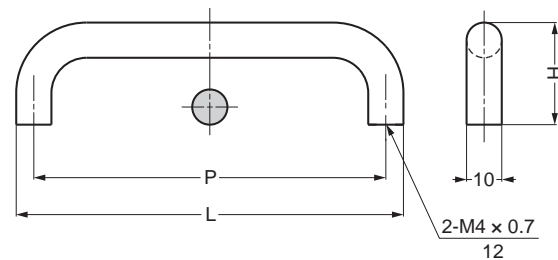

Item Code	Item Name	Material	Finish	L	P	H	Weight	Box	Carton
100-012-896	KK-M 80SNI	Aluminum Alloy	Nickel+Antibacterial Coating	80	70	28	20g	25pcs	200pcs
100-012-897	KK-M 80SSG	Aluminum Alloy	Satin Gold+Antibacterial Coating	80	70	28	20g	25pcs	200pcs
100-012-898	KK-M 80SBR	Aluminum Alloy	Brown+Antibacterial Coating	80	70	28	20g	25pcs	200pcs
100-012-899	KK-M 110SNI	Aluminum Alloy	Nickel+Antibacterial Coating	110	100	29	25g	25pcs	200pcs
100-012-900	KK-M 110SSG	Aluminum Alloy	Satin Gold+Antibacterial Coating	110	100	29	25g	25pcs	200pcs
100-012-901	KK-M 110SBR	Aluminum Alloy	Brown+Antibacterial Coating	110	100	29	25g	25pcs	200pcs
100-012-902	KK-M 130SNI	Aluminum Alloy	Nickel+Antibacterial Coating	130	120	30	30g	25pcs	200pcs
100-012-903	KK-M 130SSG	Aluminum Alloy	Satin Gold+Antibacterial Coating	130	120	30	30g	25pcs	200pcs
100-012-904	KK-M 130SBR	Aluminum Alloy	Brown+Antibacterial Coating	130	120	30	30g	25pcs	200pcs



# HANDLE



# KK-H

• Antibacterial coating.

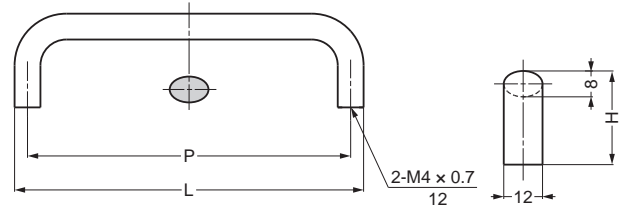

Item Code	Item Name	Material	Finish	L	P	H	Weight	Box	Carton
100-012-887	KK-H80SN I	Aluminum Alloy	Nickel + Antibacterial Coating	78	70	28	20g	25pcs	200pcs
100-012-888	KK-H80SSG	Aluminum Alloy	Satin Gold + Antibacterial Coating	78	70	28	20g	25pcs	200pcs
100-012-889	KK-H80SBR	Aluminum Alloy	Brown + Antibacterial Coating	78	70	28	20g	25pcs	200pcs
100-012-890	KK-H110SN I	Aluminum Alloy	Nickel + Antibacterial Coating	108	100	29	25g	25pcs	200pcs
100-012-891	KK-H110SSG	Aluminum Alloy	Satin Gold + Antibacterial Coating	108	100	29	25g	25pcs	200pcs
100-012-892	KK-H110SBR	Aluminum Alloy	Brown + Antibacterial Coating	108	100	29	25g	25pcs	200pcs
100-012-893	KK-H130SN I	Aluminum Alloy	Nickel + Antibacterial Coating	128	120	30	30g	25pcs	200pcs
100-012-894	KK-H130SSG	Aluminum Alloy	Satin Gold + Antibacterial Coating	128	120	30	30g	25pcs	200pcs
100-012-895	KK-H130SBR	Aluminum Alloy	Brown + Antibacterial Coating	128	120	30	30g	25pcs	200pcs

# PLASTIC HANDLE



# PC

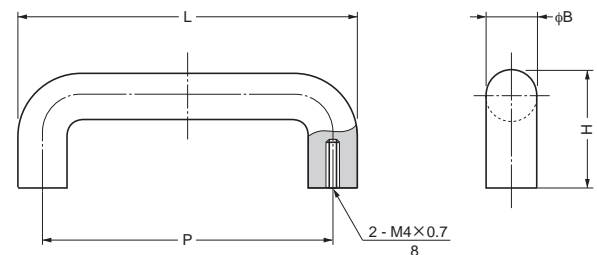

Item Code	Item Name	Material	Color	L	H	P	φ B	Weight	Box
100-015-502	PC-45-W	Polystyrene	White	45	28	35	10	7.5g	60pcs
100-015-503	PC-80-W	Polystyrene	White	80	28	68	12	14g	60pcs
100-015-504	PC-120-W	Polystyrene	White	120	29	108	12	18.3g	60pcs
100-015-505	PC-45-B	Polystyrene	Black	45	28	35	10	7.5g	60pcs
100-015-506	PC-80-B	Polystyrene	Black	80	28	68	12	14g	60pcs
100-015-507	PC-120-B	Polystyrene	Black	120	29	108	12	18.3g	60pcs

# WIRE PULL



## H-42-B

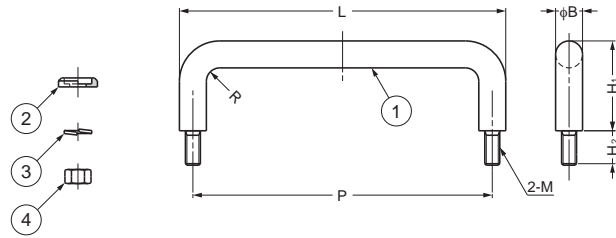

No.	Part Name	Material	Finish
①	Handle	Stainless Steel (SUS304)	Mirror
②	Mounting Plate H42-Z	Stainless Steel (SUS304)	Polished
③	Spring Washer	Stainless Steel	Plain
④	Hex Nut	Stainless Steel	Plain

Item Code	Item Name	L	H <sub>1</sub>	H <sub>2</sub>	B	P	R	M	Weight	Mounting Plate	Box	Carton
100-010-550	H-42-B-8	66	22	7	6	60	3	M4×0.7	20g	H-42-Z-6	100pcs	500pcs
100-010-552	H-42-B-14	86	30	10	6	80	3	M4×0.7	27g	H-42-Z-6	50pcs	250pcs
100-010-551	H-42-B-1	75	30	11	7	68	3.5	M5×0.8	40g	H-42-Z-7	50pcs	250pcs
100-010-553	H-42-B-2	109	30	11	9	100	4.5	M5×0.8	80g	H-42-Z-9	50pcs	150pcs
100-010-554	H-42-B-3	120	40	11	10	110	5	M6×1	120g	H-42-Z-10	50pcs	150pcs
100-010-555	H-42-B-4	130	40	11	10	120	5	M6×1	125g	H-42-Z-10	50pcs	150pcs
100-010-556	H-42-B-15	162	50	20	12	150	6	M8×1.25	235g	H-42-Z-12	30pcs	60pcs
100-010-557	H-42-B-5	200	50	20	12	188	6	M8×1.25	270g	H-42-Z-12	30pcs	60pcs
100-010-558	H-42-B-6	250	50	20	12	238	6	M8×1.25	320g	H-42-Z-12	20pcs	40pcs
100-010-559	H-42-B-7	300	50	20	12	288	6	M8×1.25	365g	H-42-Z-12	20pcs	40pcs

# WIRE PULL



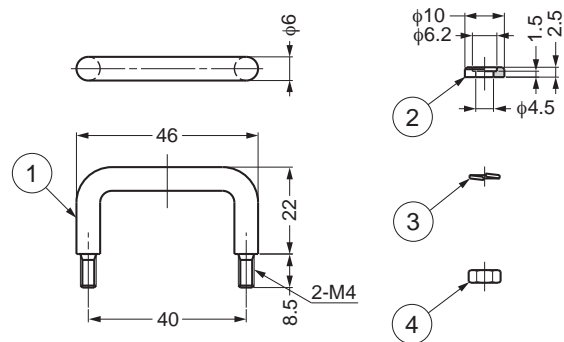

## H-42-B-9



No.	Part Name	Material	Finish
①	Handle	Stainless Steel (SUS304)	Mirror
②	Mounting Plate H42-Z	Stainless Steel (SUS304)	Polished
③	Spring Washer	Stainless Steel (SUS304)	—
④	Hex Nut	Stainless Steel (SUS304)	—

Item Code	Item Name	Weight	Box	Carton
100-019-765	H-42-B-9	15g	50pcs	500pcs

**WIRE PULL** 





**H-42-F14**

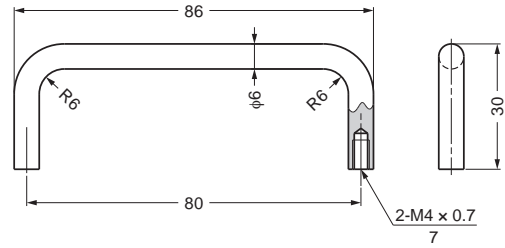

• Ideal for high corrosion environments.



Item Code	Item Name	Material	Finish	Weight	Box	Carton
100-019-233	H-42-F14	Stainless Steel (SUS316)	Mirror	25g	50pcs	250pcs

**WIRE PULL** 

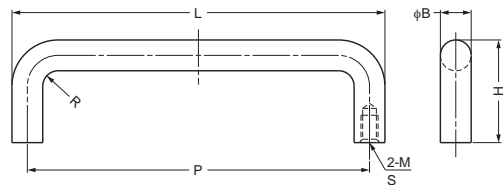

**H-42-C**



■ Handle

Item Code	Item Name	Material	Finish	L	H	B	P	S	M	R	Weight	Box	Carton
100-010-560	H-42-C-8	Stainless Steel (SUS304)	Mirror	66	22	6	60	7	M4x0.7	3	18g	100pcs	500pcs
100-010-562	H-42-C-14	Stainless Steel (SUS304)	Mirror	86	30	6	80	7	M4x0.7	3	25g	50pcs	250pcs
100-010-561	H-42-C-1	Stainless Steel (SUS304)	Mirror	75	30	7	68	8	M5x0.8	3.5	30g	50pcs	250pcs
100-010-563	H-42-C-2	Stainless Steel (SUS304)	Mirror	109	30	9	100	8	M5x0.8	4.5	65g	50pcs	150pcs
100-010-564	H-42-C-3	Stainless Steel (SUS304)	Mirror	120	40	10	110	8	M6x1	5	100g	50pcs	150pcs
100-010-565	H-42-C-4	Stainless Steel (SUS304)	Mirror	130	40	10	120	8	M6x1	5	105g	50pcs	150pcs
100-010-566	H-42-C-15	Stainless Steel (SUS304)	Mirror	162	50	12	150	10	M8x1.25	6	185g	30pcs	60pcs
100-010-567	H-42-C-5	Stainless Steel (SUS304)	Mirror	200	50	12	188	10	M8x1.25	6	220g	30pcs	60pcs
100-010-568	H-42-C-6	Stainless Steel (SUS304)	Mirror	250	50	12	238	10	M8x1.25	6	265g	20pcs	40pcs
100-010-569	H-42-C-7	Stainless Steel (SUS304)	Mirror	300	50	12	288	10	M8x1.25	6	300g	20pcs	40pcs

**WIRE PULL** 

**MG**



• Compliant with SEMI S8-0307 guideline.

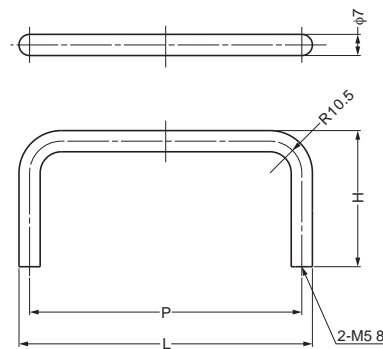

Item Code	Item Name	Material	Finish	L	H	P	Weight	Box	Carton
170-010-488	MG-68	Stainless Steel (SUS304)	Mirror	75	45	68	42g	100	300
170-010-073	MG-90	Stainless Steel (SUS304)	Mirror	97	45	90	48g	100	300

# HANDLE



LF-12

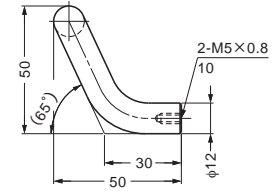
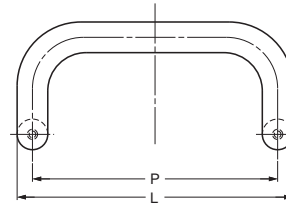

■ Handle

Item Code	Item Name	Material	Finish	L	P	Weight	Box
100-010-520	LF-12-96	Stainless Steel (SUS304)	Satin	108	96	182g	10pcs
100-010-521	LF-12-128	Stainless Steel (SUS304)	Satin	140	128	211g	10pcs
100-010-522	LF-12-160	Stainless Steel (SUS304)	Satin	172	160	236g	10pcs

# HANDLE



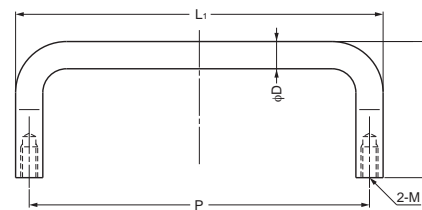

H-75-C



■ Handle

Item Code	Item Name	Material	Finish	L <sub>1</sub>	L <sub>2</sub>	S	H	P	D	M	Weight	Box	Carton
100-010-600	H-75-C-66	Stainless Steel (SUS304)	Polished	66	16	7	30	60	6	M4	23g	100pcs	400pcs
100-010-601	H-75-C-86	Stainless Steel (SUS304)	Polished	86	16	7	31.5	80	6	M4	28g	100pcs	400pcs
100-010-602	H-75-C-108	Stainless Steel (SUS304)	Polished	108	18	10	32	100	8	M5	54g	50pcs	200pcs
100-010-603	H-75-C-128	Stainless Steel (SUS304)	Polished	128	18	10	40	120	8	M5	70g	50pcs	200pcs

**WIRE PULL**    **H-75-BL-100**

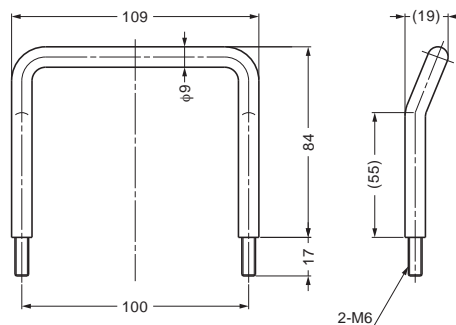

Item Code	Item Name	Material	Finish	Weight	Box
100-010-599	H-75-BL-100	Stainless Steel (SUS304)	Mirror	130g	80pcs

**BRACKET FOR HANDLE**  **AS-H30**



**Dimensions**

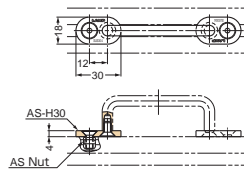

• Back mount type handle can be installed in aluminum frame from front side.

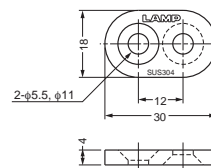

**Installation**



**Installation**

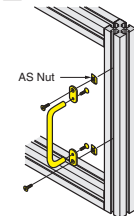

Item Code	Item Name	Material	Finish	Frame Slot	Weight
100-080-026	AS-H30	Stainless Steel (SUS304)	Mirror	Aluminum Frame slot 8-10	13g

**BRACKET FOR HANDLE**   **H42-Z**



• Can be used with wire pull.

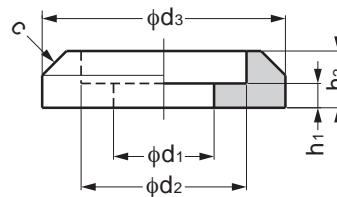

※ Sold in Set

Item Code	Item Name	Material	Finish	h <sub>1</sub>	h <sub>2</sub>	φd <sub>1</sub>	φd <sub>2</sub>	φd <sub>3</sub>	c	Handle Size	Screw Size	Weight	1Set	Box	Carton
100-010-570	H42-Z-6	Stainless Steel (SUS304)	Polished	1.5	2.5	4.5	6.2	10	1	φ6	M4	1g	2pcs	200sets	2000sets
100-010-571	H42-Z-7	Stainless Steel (SUS304)	Polished	1	3	5.2	7.2	10	1	φ7	M5	0.9g	2pcs	200sets	2000sets
100-010-572	H42-Z-9	Stainless Steel (SUS304)	Polished	1	3	5.2	9.2	13	1	φ9	M5	1.6g	2pcs	200sets	2000sets
100-010-573	H42-Z-10	Stainless Steel (SUS304)	Polished	1.5	3.5	6.2	10.2	15	1.5	φ10	M6	2.7g	2pcs	200sets	2000sets
100-010-574	H42-Z-12	Stainless Steel (SUS304)	Polished	1.5	4.5	8.2	12.2	18	1.5	φ12	M8	4.9g	2pcs	200sets	2000sets

# MEGA-RECESSED PULL (WITH BAR HANDLE)



HH-M

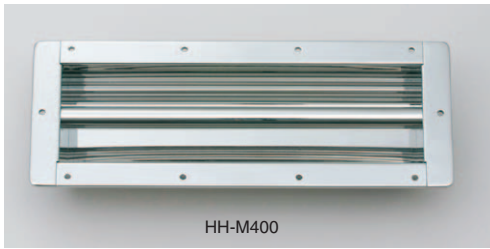

HH-M400

- Designed for industrial applications where use of thick gloves is required.
- Handlebar is recessed into cup keeping it flush and out of the way when not in use.

### ■ Bore Dimensions

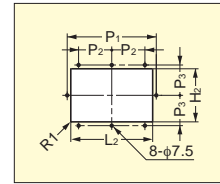
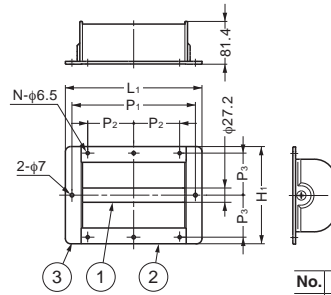

### ■ Installation

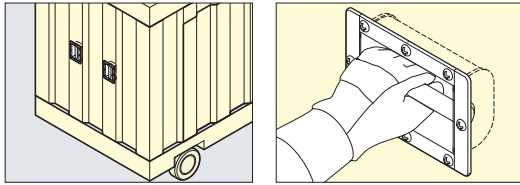

No.	Part Name	Material	Finish
①	Bar	Stainless Steel (SUS304)	Mirror
②	Cup	Stainless Steel (SUS304)	Mirror
③	Cover	Stainless Steel (SCS13)	Mirror

Item Code	Item Name	L <sub>1</sub>	L <sub>2</sub>	(H <sub>1</sub> )	H <sub>2</sub>	P <sub>1</sub>	P <sub>2</sub>	P <sub>3</sub>	N	Holes	Load Capacity	Weight	Box	Carton
100-012-306	HH-M200	260	218	185.3	140	235	87.5	80	6	8	4500N	459kgf	2.6kg	1pcs 4pcs
100-012-305	HH-M400	460	418	185.3	140	435	125	80	8	10	2200N	224kgf	3.7kg	1pcs 2pcs

# RECESSED PULL

WB-901389

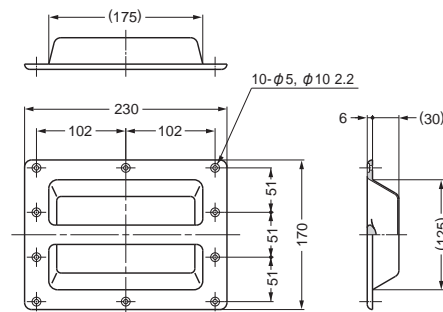

Item Code	Item Name	Material	Finish	Weight
100-012-917	WB-901389	Steel (Plastic Coating)	Black	378g

# RECESSED PULL



ES-611

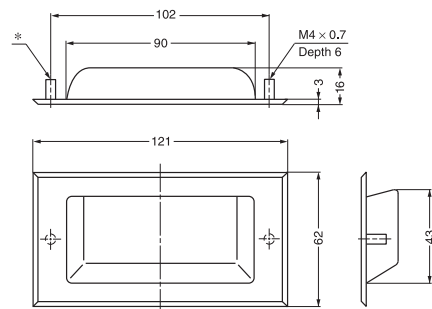

Item Code	Item Name	Weight (g)	Box (pcs)	Carton (pcs)	Material	Finish
017-659	ES-611/ET	68	20	200	304 Stainless Steel	Satin
012-957	ES-611/IT	60				

## RECESSED PULL



## HH-KS



- Ideal for harsh and high corrosion environments.

### ■ Bore Dimensions

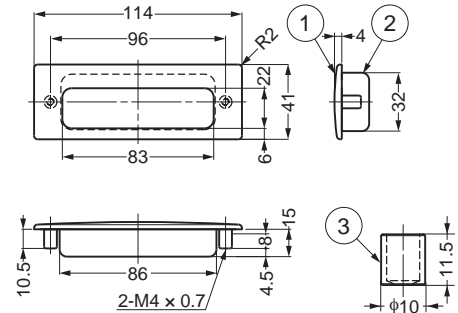
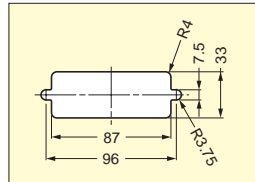

Item Code	Item Name	Finish	Weight	Box	Carton
100-010-583	HH-KS 114M	Mirror	110g	10pcs	60pcs
100-010-584	HH-KS 114S	Satin	110g	10pcs	60pcs

No.	Part Name	Material	Finish
①	Body	Stainless Steel (SCS14)	Mirror/Satin
②	Case	Stainless Steel (SUS304)	Satin
③	Base Plate	Stainless Steel (SUS304)	—

## RECESSED PULL



## HH-DS



- Ideal for harsh and high corrosion environments.

### ■ Bore Dimensions

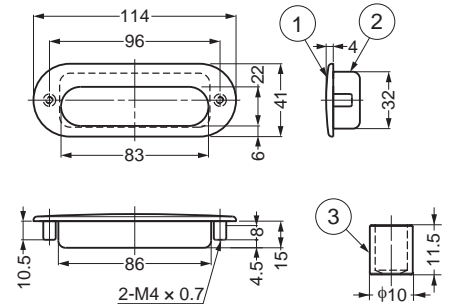
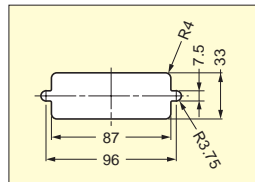

Item Code	Item Name	Finish	Weight	Box	Carton
100-010-585	HH-DS 114M	Mirror	105g	10pcs	60pcs
100-010-586	HH-DS 114S	Satin	105g	10pcs	60pcs

No.	Part Name	Material	Finish
①	Body	Stainless Steel (SCS14)	Mirror/Satin
②	Case	Stainless Steel (SUS304)	Satin
③	Base Plate	Stainless Steel (SUS304)	—

## RECESSED PULL



## HH-K



### ■ Installation

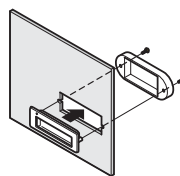

### ■ Bore Dimensions

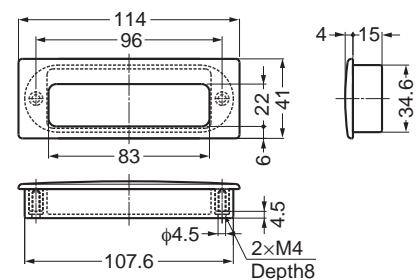
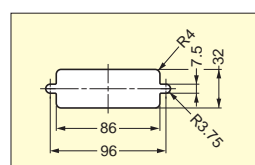

Item Code	Item Name	Material	Finish/Color	Weight	Box	Carton
100-012-952	HH-K	Stainless Steel (SCS14)/ABS	Mirror/Black	90g	10pcs	60pcs

## RECESSED PULL



## HH-D



• Ideal for harsh and high corrosion environments.

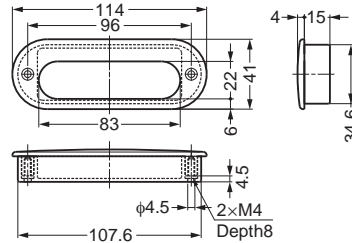

### ■ Bore Dimensions

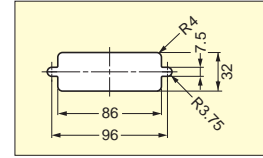

Item Code	Item Name	Material	Finish/Color	Weight	Box	Carton
100-012-951	HH-D	Stainless Steel(SCS14)/ABS	Mirror/Black	85g	10pcs	60pcs

## RECESSED PULL



## HH-KL160



### ■ Installation

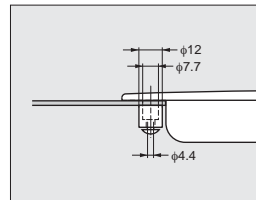

- Compliant with SEMI S8-0600 guideline.
- Spacer for sheet metal application sold separately.

### ■ Bore Dimensions

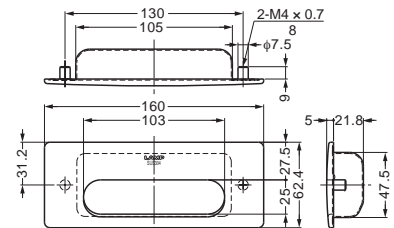
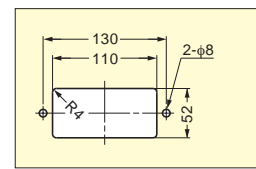

### ■ Spacer (Option)

Item Code	Item Name	Material	Finish	Weight	Box	Carton
100-012-959	HH-KL160	Stainless Steel (SCS13)	Satin	260g	8pcs	48pcs

Item Code	Item Name	Material	Finish
100-019-635	BSP-8	Steel	Yellow Zinc Chromate

## RECESSED PULL



## HH-KP150



• Compliant with SEMI S8-0600 guideline.

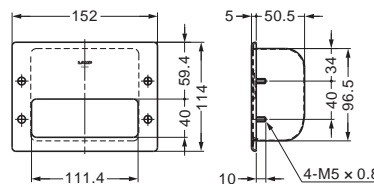
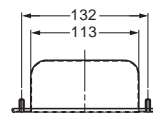

### ■ Bore Dimensions

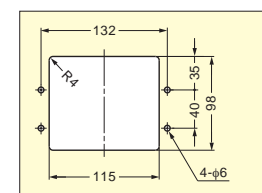

Item Code	Item Name	Material	Finish	Weight	Box	Carton
100-012-960	HH-KP150	Stainless Steel (SUS304)	Satin	390g	5pcs	50pcs



## RECESSED PULL



## HH-FB, HH-FC

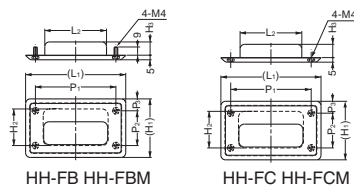

### ■ Bore Dimensions

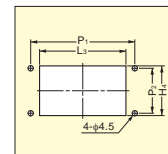

Item Code	Item Name	Bolt/Nut	Material	Finish	(L <sub>1</sub> )	L <sub>2</sub>	L <sub>3</sub>	(H <sub>1</sub> )	H <sub>2</sub>	H <sub>3</sub>	H <sub>4</sub>	P <sub>1</sub>	P <sub>2</sub>	(P <sub>3</sub> )	Weight
100-010-090	HH-FB-1	M4Bolt	Stainless Steel (SUS304)	Satin	138	96	99	88	62	21	64	110	65	11.5	170g
100-010-091	HH-FC-1	M4Nut	Stainless Steel (SUS304)	Satin	138	96	99	88	62	21	64	110	65	11.5	170g
100-010-092	HH-FB-2	M4Bolt	Stainless Steel (SUS304)	Satin	109.5	71	73	64	40	14.5	42	88	38	13	100g
100-010-093	HH-FC-2	M4Nut	Stainless Steel (SUS304)	Satin	109.5	71	73	64	40	14.5	42	88	38	13	100g
100-010-094	HH-FB-3	M4Bolt	Stainless Steel (SUS304)	Satin	94	61	63	60	43	12	45	76	32	14	80g
100-010-095	HH-FC-3	M4Nut	Stainless Steel (SUS304)	Satin	94	61	63	60	43	12	45	76	32	14	80g
100-012-104	HH-FB-1M	M4Bolt	Stainless Steel (SUS304)	Mirror	138	96	99	88	62	21	64	110	65	11.5	170g
100-012-105	HH-FC-1M	M4Nut	Stainless Steel (SUS304)	Mirror	138	96	99	88	62	21	64	110	65	11.5	170g
100-012-106	HH-FB-2M	M4Bolt	Stainless Steel (SUS304)	Mirror	109.5	71	73	64	40	14.5	42	88	38	13	100g
100-012-107	HH-FC-2M	M4Nut	Stainless Steel (SUS304)	Mirror	109.5	71	73	64	40	14.5	42	88	38	13	100g
100-012-108	HH-FB-3M	M4Bolt	Stainless Steel (SUS304)	Mirror	94	61	63	60	43	12	45	76	32	14	80g
100-012-109	HH-FC-3M	M4Nut	Stainless Steel (SUS304)	Mirror	94	61	63	60	43	12	45	76	32	14	80g

## RECESSED PULL



## HH-AS2

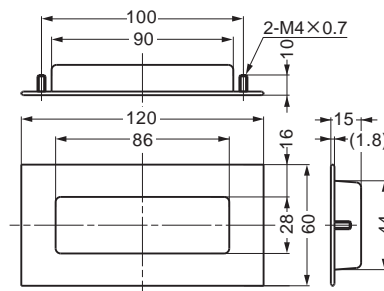

### ■ Bore Dimensions

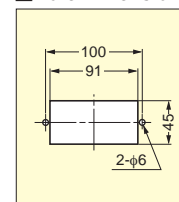

Item Code	Item Name	Material	Finish	Weight	Box	Carton
100-019-030	HH-AS2	Stainless Steel (SUS304)	Satin	50g	12pcs	240pcs

## RECESSED PULL



## HH-AS3



### ■ Option

M5Nut (Clear Zinc Chromate).

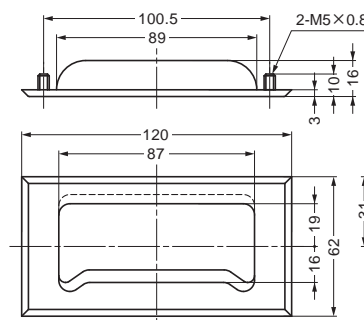

### ■ Bore Dimensions

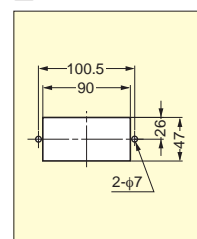

Item Code	Item Name	Material	Finish	Weight	Box	Carton
100-010-008	HH-AS3	Stainless Steel (SUS304)	Satin	50g	12pcs	240pcs

RECESSED PULL



UTZ-130

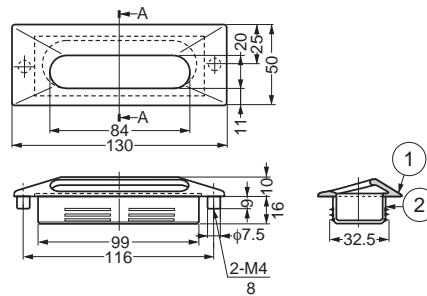

■ Bore Dimensions

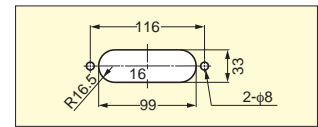

■ Installation

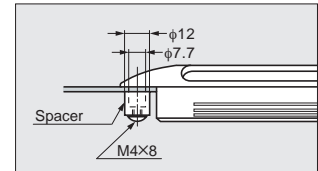

Item Code	Item Name	Finish	Weight	Box	Carton
100-010-225	UTZ-130WB	Satin Nickel	105g	10pcs	60pcs
100-010-226	UTZ-130CR	Chrome	105g	10pcs	60pcs

No.	Part Name	Material	Finish / Color
①	Body	Zinc Alloy	Chrome, Satin Nickel
②	Cup	High Impact Styrol	Black

RECESSED PULL



SD-160

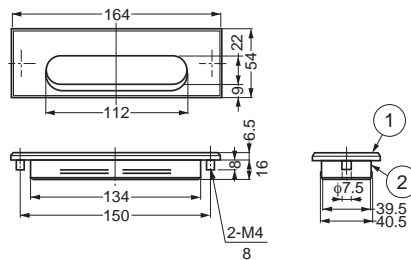
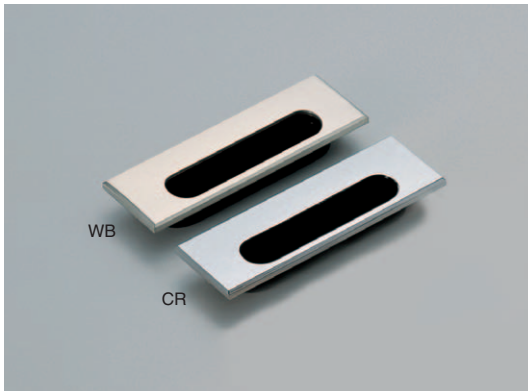

■ Bore Dimensions

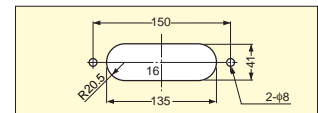

■ Installation

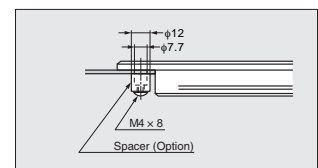

Item Code	Item Name	Finish	Box	Carton
100-010-194	SD-160WB	Satin Nickel	10pcs	60pcs
100-010-181	SD-160CR	Chrome	10pcs	60pcs

No.	Part Name	Material	Finish / Color
①	Body	Zinc Alloy	WB : Satin Nickel, CR : Chrome
②	Cup	ABS	Black

■ Spacer (Option)

Item Code	Item Name	Material	Finish
100-019-635	BSP-8	Steel	Yellow Zinc Chromate

RECESSED PULL



UT

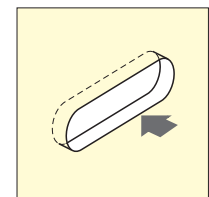
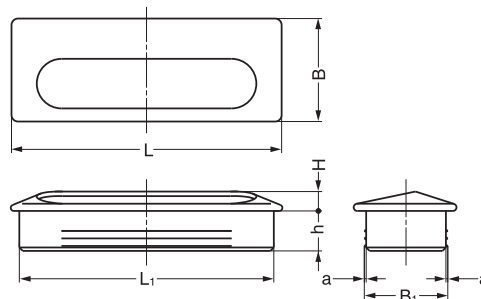

Item Code	Item Name	L	L <sub>1</sub>	H	h	B	B <sub>1</sub>	a	Weight	Box	Carton
100-010-004	UT-75/S	75	71	7	15.5	36	30.8	0.4	15g	40pcs	400pcs
100-010-161	UT-105/S	105	99	7.5	15.5	40	32.5	0.5	30g	25pcs	250pcs
100-012-850	UT-140/S	140	134	7.5	15.5	47	40.5	0.5	45g	15pcs	150pcs
100-019-663	UT-105/PB	105	99	7.5	15.5	40	32.5	0.5	30g	25pcs	250pcs

Material	Finish / Color
304 Stainless Steel	Satin (S)
Brass (UT-105/PB only)	Brass (PB) / (UT-105/PB)
Plastic	Black

# RECESSED PULL



SKH

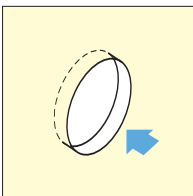
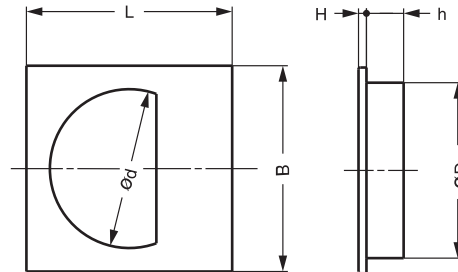

Installation

Material	Finish / Color
304 Stainless Steel	Satin (S)
Brass (SP-35/PB only)	Polished Brass (SP-35/PB)
Plastic	Black

Item Code	Item Name	L	B	H	h	D	d	Weight	Box	Carton
100-010-179	SKH-44	44	44	2.2	9.8	35.1	31	10g	100pcs	1000pcs
100-010-177	SKH-47	47	47	2.2	10.3	37.6	34	11g	60pcs	1440pcs
100-010-178	SKH-57	57	57	2.2	10.3	48.6	44	16g	50pcs	1200pcs
100-019-553	SP-35/PB	44	44	2.2	9.8	35.1	31	10g	50pcs	1000pcs

# RECESSED PULL



XLA-HHA



- Light weight design.
- Bracket for sheet metal available. Item No.: XLA-HHA40B.

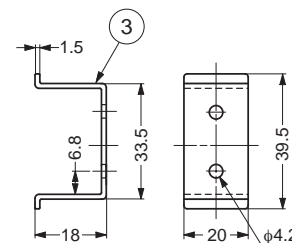
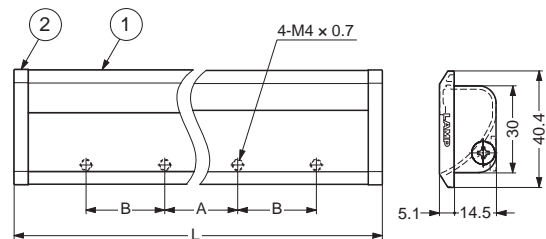

### ■ Bore Dimensions

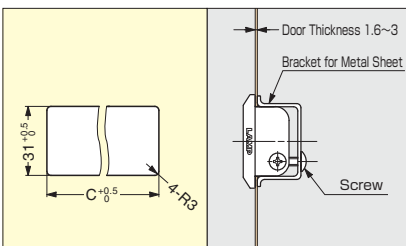

No.	Part Name	Material	Finish
①	Body	Aluminum Alloy	Matte Silver
②	Cover	Zinc Alloy	Chrome
③	Bracket for Metal Sheet (Option)	Stainless Steel (SUS430)	Polished

### ■ Bracket for Metal Sheet (Option)

Item Code	Item Name
100-010-189	XLA-HHA40B

Item Code	Item Name	L	A	B	C	Weight	Box
100-010-190	XLA-HHA300	300	100	50	297	140g	100pcs
100-010-191	XLA-HHA600	600	200	150	597	245g	50pcs



# RECESSED PULL



# HH-QTR



- Elastomer pull is ideal for medical and wash down applications.
- Snap-in type recessed pull for panel thickness of 2mm.

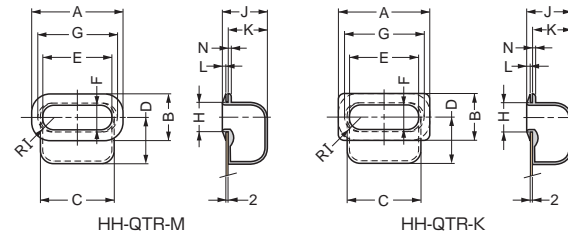

### ■ Bore Dimensions

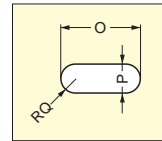

Code	Material	Color
BK	Styrene Synthetic Rubber	Black
IV	Styrene Synthetic Rubber	Ivory

Item Code	Item Name	A	B	C	D	E	F	G	H	I	J	K	L	N	O	P	Q	Weight	Box
100-010-593	HH-QTR-M1 BK	120	58	96	47	92	30	105	38	19	43	35	6	5	106	39	19.5	102g	150pcs
100-010-589	HH-QTR-K1 BK	120	58	96	47	92	30	105	38	19	43	35	6	5	106	39	19.5	95g	150pcs
100-010-595	HH-QTR-M2 BK	82	42	66	42	62	22	72	26	13	37	32	3	3	73	27	13.5	46g	300pcs
100-010-591	HH-QTR-K2 BK	82	42	66	42	62	22	72	26	13	37	32	3	3	73	27	13.5	45g	300pcs
100-010-592	HH-QTR-M1 IV	120	58	96	47	92	30	105	38	19	43	35	6	5	106	39	19.5	102g	150pcs
100-010-588	HH-QTR-K1 IV	120	58	96	47	92	30	105	38	19	43	35	6	5	106	39	19.5	95g	150pcs
100-010-594	HH-QTR-M2 IV	82	42	66	42	62	22	72	26	13	37	32	3	3	73	27	13.5	46g	300pcs
100-010-590	HH-QTR-K2 IV	82	42	66	42	62	22	72	26	13	37	32	3	3	73	27	13.5	45g	300pcs

# RECESSED PULL



# HH-P130



- Made with PVC material:
  - Ideal for semiconductor, manufacturing machinery and transparent applications.
  - Weather proof, chemical proof.
- Large opening allows for easy accessibility with gloved hands.
- Environmentally friendly - Lead free.
- Compliant with SEMI S8-0308 guideline.

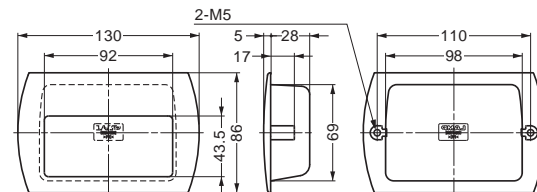

### ■ Bore Dimensions

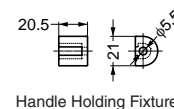
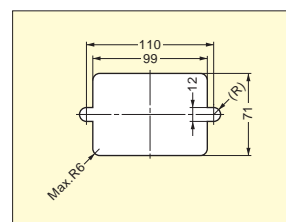

Item Code	Item Name	Material	Color	Door Thickness	Weight	Box
100-013-957	HH-P130	Chloroethylene	Clear	1~11	100g	30pcs

# RECESSED PULL (BACK MOUNT)



## HH-PS99



### Installation

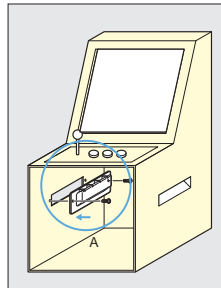

### A

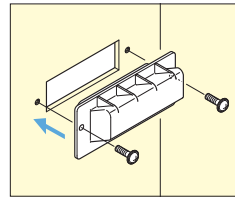

- Designed for back mounting.
- For panel thickness of 15mm.



### Bore Dimensions

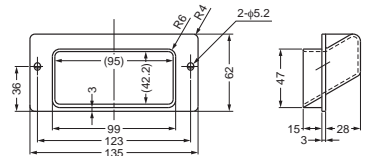
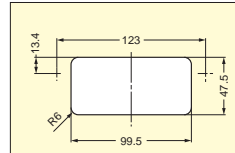

Item Code	Item Name	Material	Color	Door Thickness	Weight	Carton
100-010-343	HH-PS99	Polypropylene	Black	15	41g	200pcs

# RECESSED PULL

## WB-901390

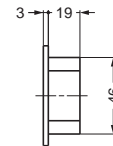
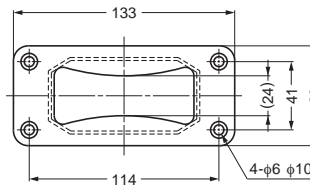
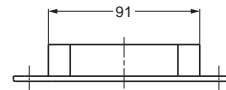

Item Code	Item Name	Material	Color	Weight	Box
100-012-918	WB-901390	Reinforced Nylon	Black	44g	75pcs

# RECESSED PULL



## ATS-100



- Snap-in type recessed pull for sheet metal thickness 0.8/1.6mm.

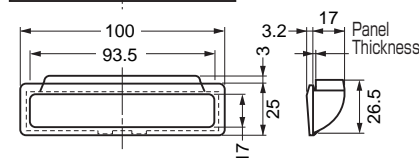
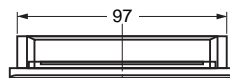

### Bore Dimensions

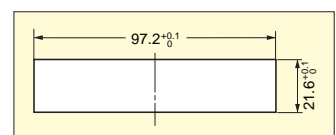

Item Code	Item Name	Material	Color	Panel Thickness	Weight	Box
100-019-180	ATS-100-I	ABS	Ivory	0.8	12.5g	550pcs
100-015-002	ATS-100-BR	ABS	Brown	0.8	12.5g	550pcs
100-019-476	ATS-100-B	ABS	Black	0.8	12.5g	550pcs
100-013-226	ATS-100-16I	ABS	Ivory	1.6	12g	1100pcs
100-013-227	ATS-100-16BR	ABS	Brown	1.6	12g	1100pcs
100-013-228	ATS-100-16B	ABS	Black	1.6	12g	1100pcs



## RECESSED PULL



### AT-100

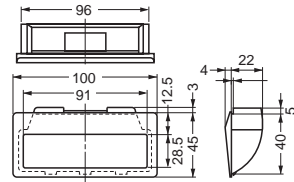

■ Bore Dimensions

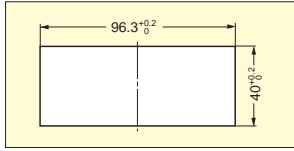

Item Code	Item Name	Material	Color	Door Thickness	Weight	Box
100-017-625	AT-100-I	ABS	Ivory	0.8	23g	250pcs
100-017-626	AT-100-BR	ABS	Brown	0.8	23g	250pcs
100-019-414	AT-100-B	ABS	Black	0.8	23g	250pcs
100-013-211	AT-100-10I	ABS	Ivory	1.0	22.6g	250pcs
100-013-212	AT-100-10BR	ABS	Brown	1.0	22.6g	250pcs
100-013-213	AT-100-10B	ABS	Black	1.0	22.6g	250pcs
100-013-214	AT-100-12I	ABS	Ivory	1.2	22.4g	250pcs
100-013-215	AT-100-12BR	ABS	Brown	1.2	22.4g	250pcs
100-013-216	AT-100-12B	ABS	Black	1.2	22.4g	250pcs
100-013-217	AT-100-16I	ABS	Ivory	1.6	22.3g	250pcs
100-013-218	AT-100-16BR	ABS	Brown	1.6	22.3g	250pcs
100-013-219	AT-100-16B	ABS	Black	1.6	22.3g	250pcs

## RECESSED PULL



### AT-70

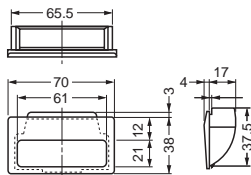

■ Bore Dimensions

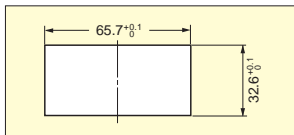

• Snap-in type recessed pull for sheet metal thickness 0.8mm.

Item Code	Item Name	Material	Color	Door Thickness	Weight	Box
100-015-001	AT-70-I	ABS	Ivory	0.8	12g	550pcs
100-017-627	AT-70-BR	ABS	Brown	0.8	12g	550pcs
100-015-000	AT-70-B	ABS	Black	0.8	12g	550pcs
100-013-220	AT-70-12I	ABS	Ivory	1.2	12.8g	1100pcs
100-013-221	AT-70-12BR	ABS	Brown	1.2	12.8g	1100pcs
100-013-222	AT-70-12B	ABS	Black	1.2	12.8g	1100pcs
100-013-223	AT-70-16I	ABS	Ivory	1.6	12.8g	1100pcs
100-013-224	AT-70-16BR	ABS	Brown	1.6	12.8g	1100pcs
100-013-225	AT-70-16B	ABS	Black	1.6	12.8g	1100pcs

## RECESSED PULL



### YK-W100

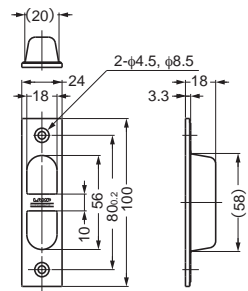

■ Bore Dimensions

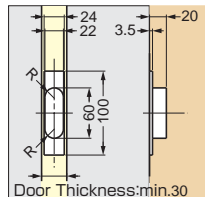

• Ideal for pocket door application.

Item Code	Item Name	Weight	Box	Carton
100-010-391	YK-W100	45g	20pcs	160pcs

No.	Part Name	Material	Finish
①	Body	Stainless Steel	Satin
②	Case	(SUS304)	Plain

## RECESSED PULL



### YK-70

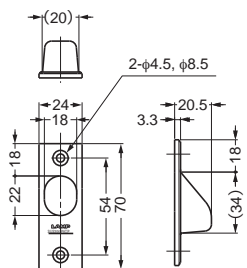

■ Bore Dimensions

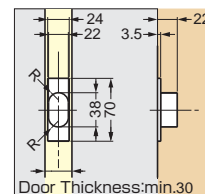

• Ideal for pocket door application.

Item Code	Item Name	Weight	Box	Carton
100-010-390	YK-70	37g	20pcs	200pcs

No.	Part Name	Material	Finish
①	Body	Stainless Steel	Satin
②	Case	(SUS304)	Plain

## RECESSED PULL



HN

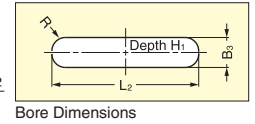
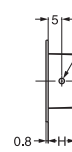
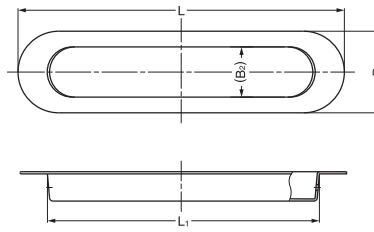

Material	Finish
304 Stainless Steel	Satin

Item Code	Item Name	L	L <sub>1</sub>	H	B	B <sub>1</sub>	B <sub>2</sub>	L <sub>2</sub>	B <sub>3</sub>	H <sub>1</sub>	Weight	Box	Carton
100-012-953	HN-120SH	120	100	10	30	20	18.5	100.5	20.5	10.5	19g	50pcs	500pcs
100-012-954	HN-150SH	150	130	12	35	26	24.5	130.5	26.5	12.5	27g	20pcs	200pcs
100-012-955	HN-200SH	200	170	13.2	50	36	34.5	170.5	36.5	13.7	50g	10pcs	100pcs
100-012-956	HN-250SN	250	220	13.2	50	36	34.5	220.5	36.5	13.7	92g	10pcs	100pcs

## RECESSED PULL



SMH

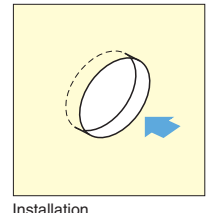
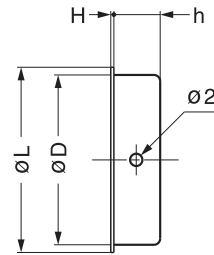
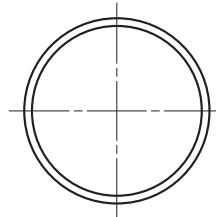

Material	Finish
304 Stainless Steel	Satin

Item Code	Item Name	L	H	h	D	Weight	Box	Carton
100-010-184	SMH-30	30	0.5	7.5	27.5	4g	100pcs	3600pcs
100-010-185	SMH-37	36	0.5	8.5	31.5	6g	100pcs	3600pcs
100-010-186	SMH-45	46	0.5	8.5	41	9.5g	100pcs	2400pcs
100-010-187	SMH-60	60	0.5	9.5	53.5	15g	50pcs	1200pcs
100-010-188	SMH-80	80	0.5	9.5	71	25.5g	25pcs	500pcs

## RECESSED PULL



OP-150

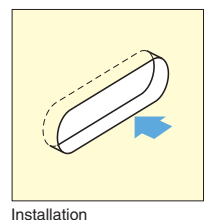
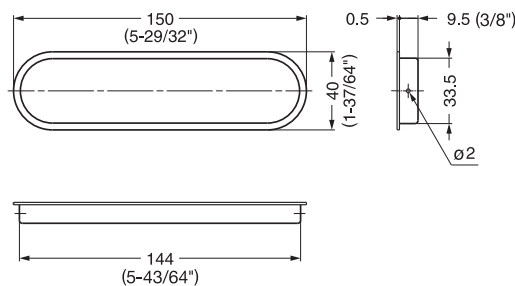

Item Code	Item Name	Weight	Box	Carton	Material	Finish
100-015-016	OP-150	30g	30pcs	720pcs	304 Stainless Steel	Satin

## STAINLESS STEEL FOLDING RING PULL



26700



- The pull is recessed into the mounting plate keeping it flush with the mounting surface.
- Low profile design.

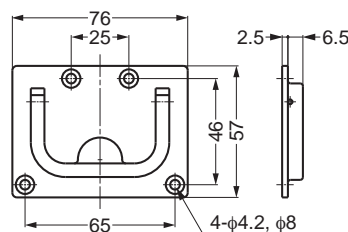

### ■ Bore Dimensions

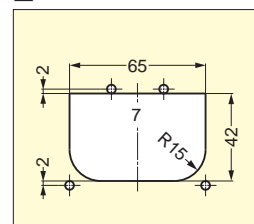

Item Code	Item Name	Material	Finish	Weight	Box	Carton
100-096-011	26700	Stainless Steel (SCS14)	Mirror	120g	10pcs	100pcs

SCS14 is similar to SUS316.

## STAINLESS STEEL FOLDING RING PULL



26900



- The pull is recessed into the mounting plate keeping it flush with the mounting surface.
- Low profile design.

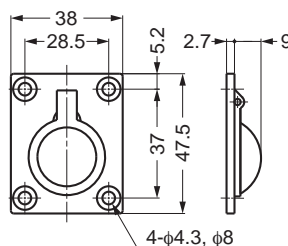

### ■ Bore Dimensions

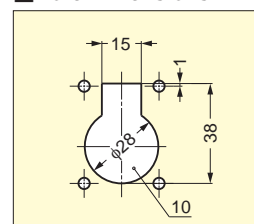

Item Code	Item Name	Material	Finish	Weight	Box	Carton
100-096-009	26900	Stainless Steel (SCS14)	Mirror	45g	20pcs	100pcs

SCS14 is similar to SUS316.

## STAINLESS STEEL FOLDING RING PULL



26901



- The pull is recessed into the mounting plate keeping it flush with the mounting surface.
- Low profile design.

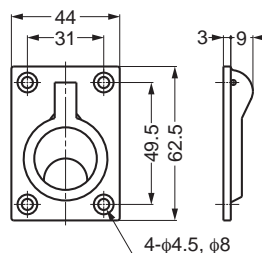

### ■ Bore Dimensions

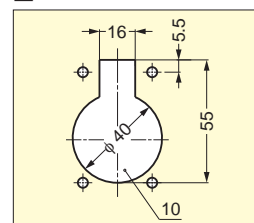

Item Code	Item Name	Material	Finish	Weight	Box	Carton
100-096-010	26901	Stainless Steel (SCS14)	Mirror	85g	20pcs	100pcs

SCS14 is similar to SUS316.



FOLDING RING PULL (SPRING LOADED)



980641, 980642



- The pull is recessed into the mounting plate keeping it flush with the mounting surface.
- Low profile design.
- Spring loaded-snaps flat to stay out of the way when not in use.
- Ideal for vibration or shock applications.

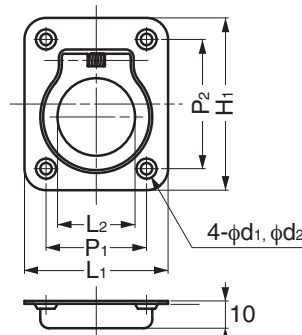

■ Bore Dimensions

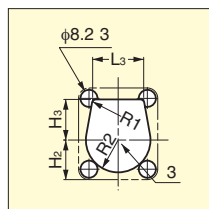

■ For sheet metal

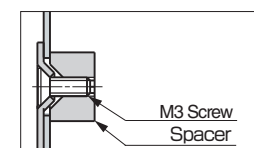

Item Code	Item Name	Material	Finish	L1	L2	L3	H1	H2	H3	R1	φR2	P1	P2	d1	d2	Load Capacity	Weight	Box
100-011-737	980641	Stainless Steel (SUS304)	Mirror	38	18	24.5	44	19	19.5	14.2	14.2	28	34	4	6.2	20kgf	35g	10pcs
100-011-738	980642	Stainless Steel (SUS304)	Mirror	50	27	25	60	25	25	19.5	19.5	35	45	4.4	7	25kgf	52.5g	10pcs

FOLDING RING PULL (SPRING LOADED)



980640



- The pull is recessed into the mounting plate keeping it flush with the mounting surface.
- Low profile design.
- Spring loaded-snaps flat to stay out of the way when not in use.
- Ideal for vibration or shock applications.

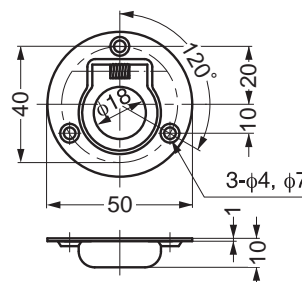

■ Bore Dimensions

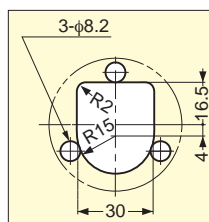

■ For Sheet metal

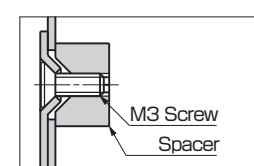

Item Code	Item Name	Material	Finish	Load Capacity	Weight	Box
100-011-740	980640	Stainless Steel (SUS304)	Mirror	20kgf	23g	10pcs

# TRUNK HANDLE



## HCT-150



- 316 Stainless steel handle is ideal for harsh and high corrosion environments.
- The handle is recessed into the mounting plate keeping it flush with the mounting surface.
- Spring loaded:  
Folds and returns to flat position to stay out of the way when not in use.
- 90 degree stop feature.
- Back mounting.

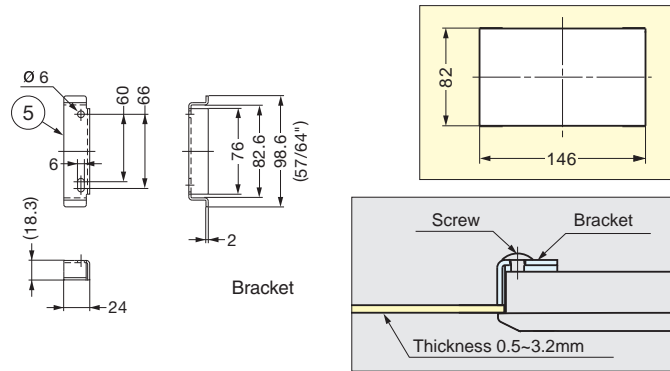
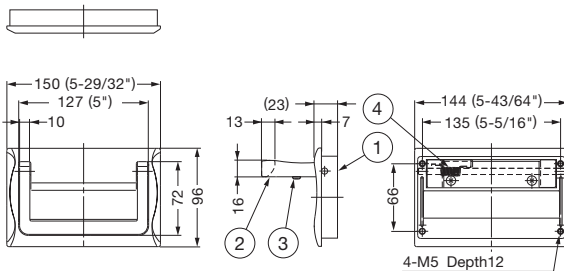

No.	Part Name	Material	Finish
①	Body	316 Stainless Steel	Mirror
②	Handle		
③	Bumper	Ethylene Propylene	Black
④	Spring	316 Stainless Steel	—
⑤	Bracket		Plain

Item Code	Item Name	Material	Finish	Load Capacity	Weight	Box	Carton
100-017-557	HCT-150	316 Stainless Steel	Mirror	980N	100kgf	5pcs	20pcs

# TRUNK HANDLE



## MUD-140



- The handle is recessed into the mounting plate keeping it flush with the mounting surface.
- Spring loaded:  
Folds and returns to flat position to stay out of the way when not in use.
- 90 degree stop feature.
- Rubber pad on handle provides an easy and comfortable grip.
- Back mounting.

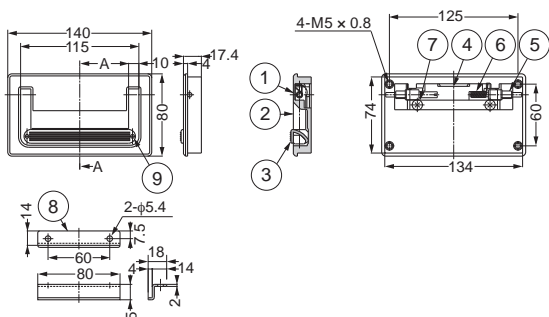

### Installation

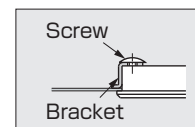

### Bore Dimensions

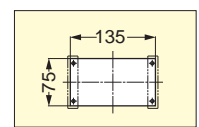

No.	Part Name	Material	Finish/Color
①	Body	Zinc Alloy	Chrome
②	Handle	Zinc Alloy	Chrome
③	Grip	Synthetic Rubber	Black
④	Back Cover	Steel	Yellow Zinc Chromate
⑤	Shaft	Zinc Alloy	Yellow Zinc Chromate
⑥	Spring	Steel	Yellow Zinc Chromate
⑦	Screw	Steel	—
⑧	Bracket	Steel	Yellow Zinc Chromate
⑨	Grip Screw	Stainless Steel	Black

Item Code	Item Name	Load Capacity	Weight	Box	Carton
100-901-272	MUD-140	294N	30kgf	620g	5pcs

# TRUNK HANDLE



# TMU-115



- The handle is recessed into the mounting plate keeping it flush with the mounting surface.
- Spring loaded:  
Folds and returns to flat position to stay out of the way when not in use.
- 90 degree stop feature.
- Rubber pad on handle provides an easy and comfortable grip.
- Front and back mounting options.

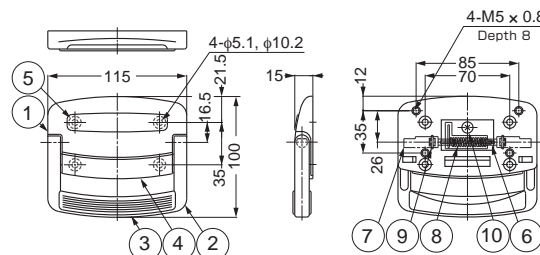

No.	Part Name	Material	Finish/Color
①	Body	Zinc Alloy	Chrome
②	Handle	Zinc Alloy	Chrome
③	Grip	Synthetic Rubber	Black
④	Case Cover 1	Synthetic Rubber	Black
⑤	Case Cover 2	Synthetic Rubber	Black
⑥	Back Cover	Steel	Yellow Zinc Chromate
⑦	Shaft	Steel	Nickel
⑧	Spring	Steel	Yellow Zinc Chromate
⑨	Pivot Ring	—	5103-31
⑩	Screw	Steel	Yellow Zinc Chromate

Item Code	Item Name	Load Capacity	Weight	Box	Carton
100-901-273	TMU-115	392N	40kgf	460g	10pcs / 40pcs

# TRUNK HANDLE



# PT-148

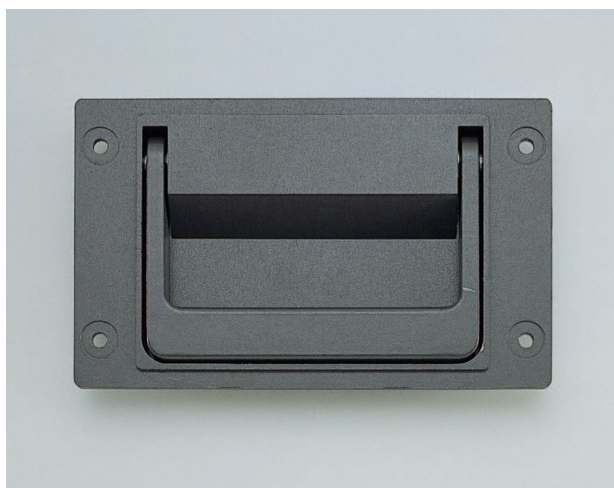

- The handle is recessed into the mounting plate keeping it flush with the mounting surface.
- Spring loaded:  
Folds and returns to flat position to stay out of the way when not in use.
- 90 degree stop feature.
- Front and back mounting options.

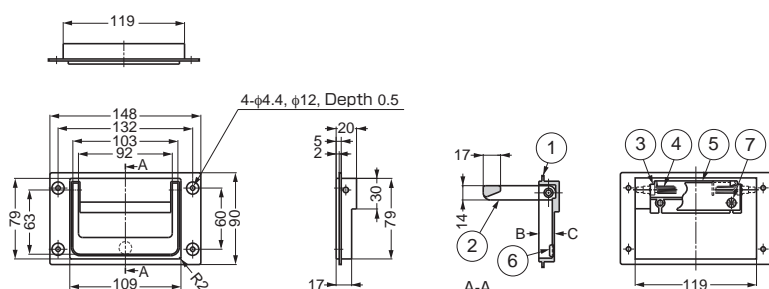

### Bore Dimensions

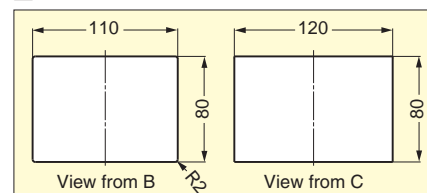

No.	Part Name	Material	Finish/Color
①	Body	Zinc Alloy	Grey
②	Handle	Zinc Alloy	Grey
③	Shaft	Steel	Plain
④	Spring	Spring Steel	—
⑤	Back Cover	Steel	—
⑥	Bumper	Synthetic Rubber	Clear
⑦	Screw	Steel	Chromate

Item Code	Item Name	Load Capacity	Weight	Box
100-019-183	PT-148	490N	50kgf	645g / 20pcs

# FOLDING RING PULL (SPRING LOADED)



TO



- Folding handle provides ample grabbing room under the handle for gloved hands.
- Spring loaded-snaps back into flat position to stay out of the way when not in use.

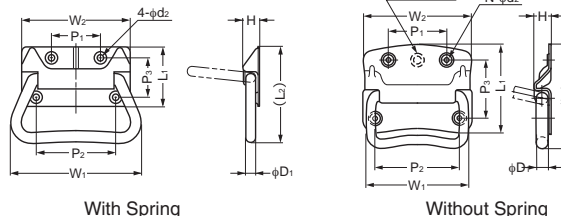

Item Code	Item Name	Spec.	Material	Finish	L <sub>1</sub>	L <sub>2</sub>	W <sub>1</sub>	W <sub>2</sub>	H	P <sub>1</sub>	P <sub>2</sub>	P <sub>3</sub>	φD <sub>1</sub>	φd <sub>2</sub>	N	Weight	Box	Carton
100-012-269	TO-85SS	With Spring	Stainless Steel (SUS304)	Satin	40	62	84	70	12	32	52	24	7	4.5	4	90g	10pcs	200pcs
100-012-270	TO-105SS	With Spring	Stainless Steel (SUS304)	Satin	47	75	105	88	13	40	65	30	8	5.5	4	151g	10pcs	250pcs
100-012-267	TO-85	With Spring	Steel	Chromate	40	62	84	70	12	32	52	24	7	4.5	4	90g	10pcs	200pcs
100-012-268	TO-105	With Spring	Steel	Chromate	47	75	105	88	13	40	65	30	8	5.5	4	153g	10pcs	250pcs
100-012-263	TO-70	Without Spring	Steel	Chromate	54	69	60	68	9	-	49	34	6	4.7	3	60g	10pcs	460pcs
100-012-264	TO-80	Without Spring	Steel	Chromate	73	80	75	83	11	45	63	43	7	5	4	104g	10pcs	300pcs
100-012-265	TO-90	Without Spring	Steel	Chromate	75	91	82	90	12	48	69	47	8	5.5	4	135g	10pcs	240pcs
100-012-266	TO-100	Without Spring	Steel	Chromate	85	105	95	102	14	51	76	54	9	6	4	210g	10pcs	120pcs

# HANDLE



WB-901228

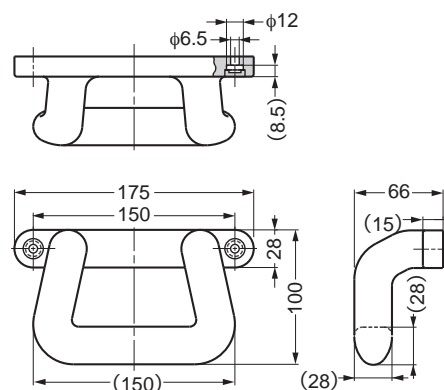

Item Code	Item Name	Material	Color	Weight
100-012-915	WB-901228	Polyurethane (Steel Core)	Black	478g

# HATCH PULL



## ST-90, 115



- The handle is concealed when not in use to stay out of the way.
- T-handle design.

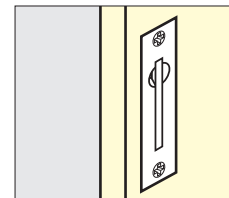
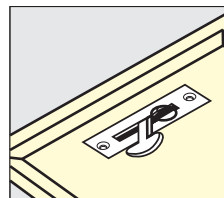
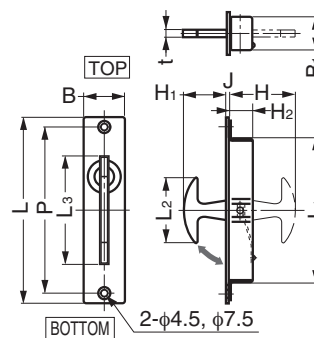

Item Code	Item Name	Material	Finish	L	L <sub>1</sub>	L <sub>2</sub>	L <sub>3</sub>	H	H <sub>1</sub>	H <sub>2</sub>	J	B	B <sub>1</sub>	t	P	Weight	Box	Carton
100-010-240	ST-90	Stainless Steel (SUS304)	Satin	90	66.2	30.2	57	35.5	23.2	10.5	2.2	22	18.5	3.8	80	68g	30pcs	300pcs
100-010-241	ST-115	Stainless Steel (SUS304)	Satin	115	86.2	40	67	42	26	13	2.5	25	20	4	102	102g	20pcs	200pcs

# HATCH PULL



## ST-80, 100



- The handle is concealed when not in use to stay out of the way.
- Hook design.

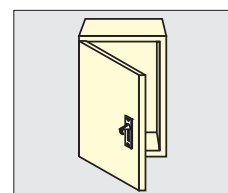
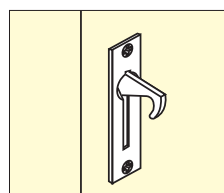
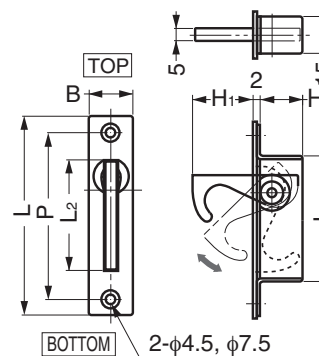

Item Code	Item Name	Material	Finish	L	L <sub>1</sub>	L <sub>2</sub>	H	H <sub>1</sub>	B	P	Weight	Box	Carton
100-010-244	ST-80	Stainless Steel (SUS304)	Satin	80	50	44	18	25	18	68	48g	30pcs	300pcs
100-010-245	ST-100	Stainless Steel (SUS304)	Satin	100	63	54	21	32	20	85	66g	20pcs	200pcs

## HATCH PULL



## HR



- The handle is concealed when not in use to stay out of the way.

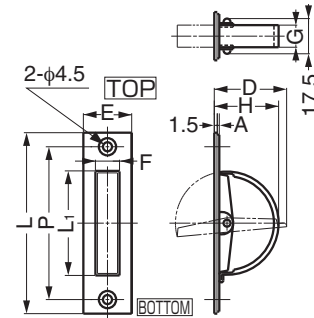

Item Code	Item Name	Material	Finish	L	L <sub>1</sub>	P	H	D	A	E	F	G	Load Capacity	Weight	Box	Carton	
100-012-614	HR-90S	Stainless Steel (SUS304)	Satin	90	52	76	32	36	1	24	12	11	127N	13kgf	49g	30pcs	300pcs
100-012-615	HR-110S	Stainless Steel (SUS304)	Satin	110	64	94	38	42	1	24	12	11	98N	10kgf	59g	20pcs	200pcs
100-012-817	HR-135S	Stainless Steel (SUS304)	Satin	135	90	115	50	55	1.2	25	12.2	12	-	-	88g	15pcs	150pcs

## HATCH PULL



## HR-R



- The handle is concealed when not in use to stay out of the way.

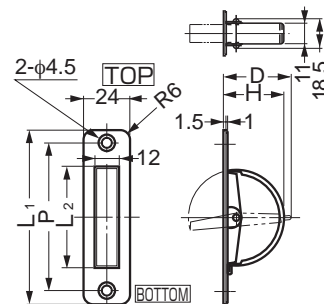

Item Code	Item Name	Material	Finish	L <sub>1</sub>	L <sub>2</sub>	P	H	D	Load Capacity	Weight	Box	Carton	
100-019-058	HR-90RS	Stainless Steel (SUS304)	Satin	90	52	76	32	36	127N	13kgf	46g	30pcs	300pcs
100-019-059	HR-110RS	Stainless Steel (SUS304)	Satin	110	64	94	38	42	98N	10kgf	55g	20pcs	200pcs

PULL



SND

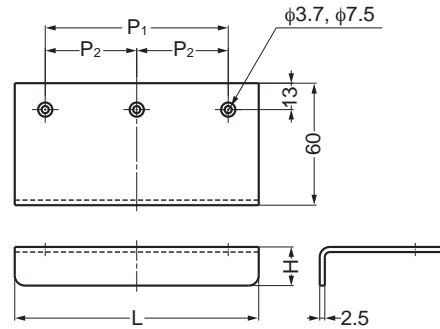

Item Code	Item Name	Material	Finish	L	H	P <sub>1</sub>	P <sub>2</sub>	Holes	Weight	Box	Carton
100-010-150	SND-50M	Stainless Steel (SUS304)	Mirror	50	17	30	-	2	67g	10pcs	200pcs
100-010-151	SND-70M	Stainless Steel (SUS304)	Mirror	70	17	46	-	2	95g	10pcs	200pcs
100-010-152	SND-95M	Stainless Steel (SUS304)	Mirror	95	18	65	-	2	130g	5pcs	100pcs
100-010-153	SND-120M	Stainless Steel (SUS304)	Mirror	120	19	90	45	3	166g	5pcs	50pcs
100-010-154	SND-150M	Stainless Steel (SUS304)	Mirror	150	19	114	57	3	208g	5pcs	50pcs

PULL



SN

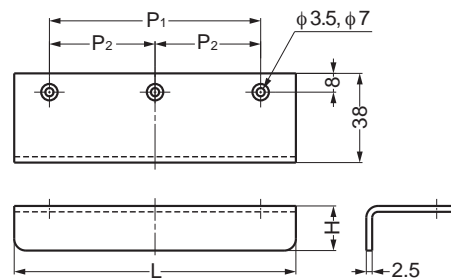

Item Code	Item Name	Material	Finish	L	H	P <sub>1</sub>	P <sub>2</sub>	Holes	Weight	Box	Carton
100-010-162	SN-50S	Stainless Steel (SUS304)	Satin	50	17	30	-	2	47g	40pcs	400pcs
100-010-155	SN-50M	Stainless Steel (SUS304)	Mirror	50	17	30	-	2	47g	40pcs	400pcs
100-010-163	SN-70S	Stainless Steel (SUS304)	Satin	70	17	46	-	2	65g	30pcs	300pcs
100-010-156	SN-70M	Stainless Steel (SUS304)	Mirror	70	17	46	-	2	65g	30pcs	300pcs
100-010-164	SN-95S	Stainless Steel (SUS304)	Satin	95	18	65	-	2	90g	20pcs	200pcs
100-010-157	SN-95M	Stainless Steel (SUS304)	Mirror	95	18	65	-	2	90g	20pcs	200pcs
100-010-165	SN-120S	Stainless Steel (SUS304)	Satin	120	19	90	45	3	112g	20pcs	200pcs
100-010-158	SN-120M	Stainless Steel (SUS304)	Mirror	120	19	90	45	3	112g	20pcs	200pcs
100-010-166	SN-150S	Stainless Steel (SUS304)	Satin	150	19	114	57	3	147g	15pcs	150pcs
100-010-159	SN-150M	Stainless Steel (SUS304)	Mirror	150	19	114	57	3	147g	15pcs	150pcs

**KNOB**



**RSS**



• Light weight design.

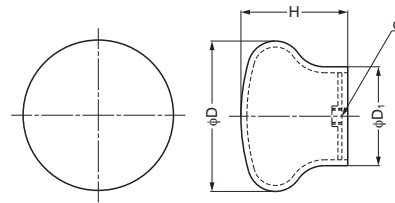

Item Code	Item Name	Material	Finish	H	D	D <sub>1</sub>	d	Weight	Box	Carton
100-011-194	RSS-25S	Stainless Steel (SUS304)	Satin	22	25	18	M4x0.7	8.5g	20pcs	200pcs
100-011-190	RSS-25M	Stainless Steel (SUS304)	Mirror	22	25	18	M4x0.7	8.5g	20pcs	200pcs
100-011-195	RSS-30S	Stainless Steel (SUS304)	Satin	23	30	20	M4x0.7	11g	20pcs	200pcs
100-011-191	RSS-30M	Stainless Steel (SUS304)	Mirror	23	30	20	M4x0.7	11g	20pcs	200pcs
100-011-196	RSS-38S	Stainless Steel (SUS304)	Satin	27	38	25	M5x0.8	16g	20pcs	200pcs
100-011-192	RSS-38M	Stainless Steel (SUS304)	Mirror	27	38	25	M5x0.8	16g	20pcs	200pcs
100-011-197	RSS-50S	Stainless Steel (SUS304)	Satin	34	50	35	M5x0.8	30g	20pcs	200pcs
100-011-193	RSS-50M	Stainless Steel (SUS304)	Mirror	34	50	35	M5x0.8	30g	20pcs	200pcs

■ Backplate (Option)

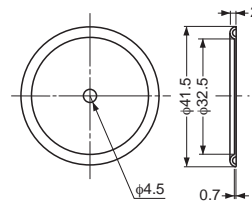
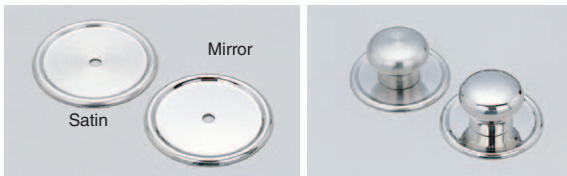

Item Code	Item Name	Material	Finish	Weight	Box	Carton
100-012-145	RSP-25S	Stainless Steel (SUS304)	Satin	6.5g	60pcs	600pcs
100-012-140	RSP-25M	Stainless Steel (SUS304)	Mirror	6.5g	60pcs	600pcs

**KNOB**



**RS-38**



• Light weight design.

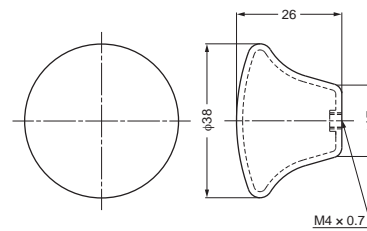

Item Code	Item Name	Material	Finish	Weight	Box	Carton
100-011-198	RS-38S	Stainless Steel(SUS304)	Satin	20g	20pcs	200pcs

**KNOB**



**EXCEL**

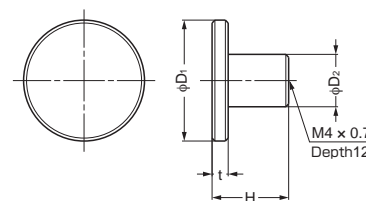

Item Code	Item Name	Material	Finish	D <sub>1</sub>	D <sub>2</sub>	H	t	Weight	Box	Carton
100-012-080	EXCEL20	Aluminum Alloy	Stainless Finish Anodized	20	10	18	4	5g	48pcs	1152pcs
100-012-081	EXCEL25	Aluminum Alloy	Stainless Finish Anodized	25	11	18.5	4.5	8.5g	48pcs	1152pcs
100-012-082	EXCEL30	Aluminum Alloy	Stainless Finish Anodized	30	12	19	5	15g	48pcs	1152pcs
100-012-083	EXCEL35	Aluminum Alloy	Stainless Finish Anodized	35	13	19	5	16.5g	24pcs	576pcs



# KNOB



# KK-T



•Antibacterial coating.

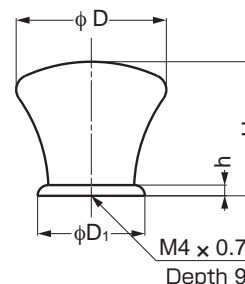

Item Code	Item Name	Material	Finish	D	D <sub>1</sub>	H	h	Weight	Box	Carton
100-012-905	KK-T24SNI	Aluminum Alloy	Nickel+Antibacterial Coating	24	16	23	1.5	10g	25pcs	200pcs
100-012-906	KK-T24SSG	Aluminum Alloy	Satin Gold+Antibacterial Coating	24	16	23	1.5	10g	25pcs	200pcs
100-012-907	KK-T24SBR	Aluminum Alloy	Brown+Antibacterial Coating	24	16	23	1.5	10g	25pcs	200pcs
100-012-908	KK-T28SNI	Aluminum Alloy	Nickel+Antibacterial Coating	28	20	26	2	20g	25pcs	200pcs
100-012-909	KK-T28SSG	Aluminum Alloy	Satin Gold+Antibacterial Coating	28	20	26	2	20g	25pcs	200pcs
100-012-910	KK-T28SBR	Aluminum Alloy	Brown+Antibacterial Coating	28	20	26	2	20g	25pcs	200pcs

# KNOB



# KK-B



•Antibacterial coating.

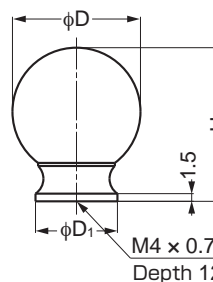

Item Code	Item Name	Material	Finish	D	D <sub>1</sub>	H	Weight	Box	Carton
100-012-881	KK-B20SNI	Aluminum Alloy	Nickel+Antibacterial Coating	20	13	26	10g	25pcs	200pcs
100-012-882	KK-B20SSG	Aluminum Alloy	Satin Gold+Antibacterial Coating	20	13	26	10g	25pcs	200pcs
100-012-883	KK-B20SBR	Aluminum Alloy	Brown+Antibacterial Coating	20	13	26	10g	25pcs	200pcs
100-012-884	KK-B25SNI	Aluminum Alloy	Nickel+Antibacterial Coating	25	16	30	25g	25pcs	200pcs
100-012-885	KK-B25SSG	Aluminum Alloy	Satin Gold+Antibacterial Coating	25	16	30	25g	25pcs	200pcs
100-012-886	KK-B25SBR	Aluminum Alloy	Brown+Antibacterial Coating	25	16	30	25g	25pcs	200pcs

# PULL



# SD

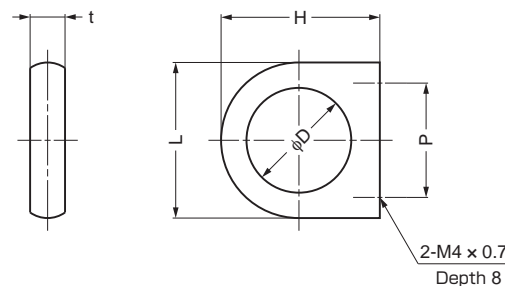

Item Code	Item Name	Material	Finish	L	H	t	D	P	S	Weight	Box	Carton
100-015-022	SD-24S	Stainless Steel (SCS13)	Satin	24.5	25	5.5	16.5	18	5	10g	80pcs	800pcs
100-015-023	SD-24M	Stainless Steel (SCS13)	Mirror	24.5	25	5.5	16.5	18	5	10g	80pcs	800pcs
100-015-020	SD-30S	Stainless Steel (SCS13)	Satin	30.5	31.5	6.5	20.5	21	6	22g	50pcs	500pcs
100-015-021	SD-30M	Stainless Steel (SCS13)	Mirror	30.5	31.5	6.5	20.5	21	6	22g	50pcs	500pcs

# RECESSED PULL



# AOT35

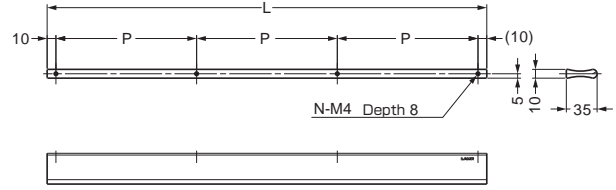
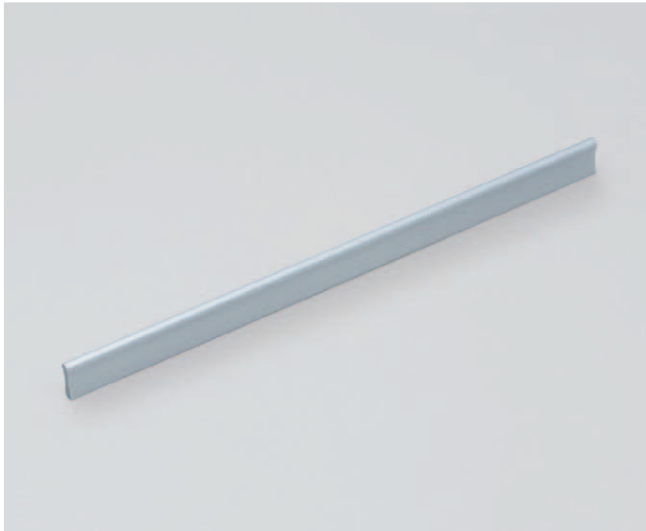

Item Code	Item Name	Material	Finish	L	P	N	Weight	Box
100-012-523	AOT35-180	Aluminum Alloy	Anodized	180	160	2	129g	100pcs
100-012-524	AOT35-340	Aluminum Alloy	Anodized	340	160	3	243g	50pcs
100-012-525	AOT35-500	Aluminum Alloy	Anodized	500	160	4	358g	30pcs

# PULL



# RD



• Ideal for harsh and high corrosion environments.

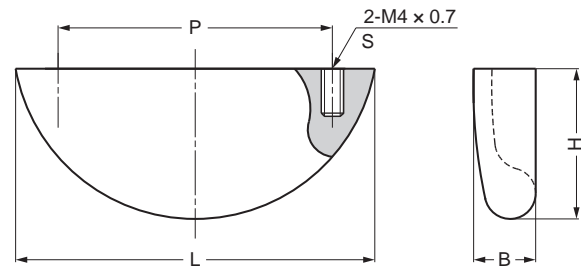

Item Code	Item Name	Material	Finish	L	H	B	P	S	Weight	Box	Carton
100-901-049	RD-55SM	Stainless Steel (SCS14)	Mirror	55	23	9.5	42	8	50g	30pcs	360pcs
100-901-050	RD-90SM	Stainless Steel (SCS14)	Mirror	90	25.5	10.5	74	10	80g	20pcs	240pcs

# KNURLED KNOB



# SRT



• With fall-preventing washer.

No.	Part Name	Material	Finish
①	Knurled Knob	Stainless Steel (SUS303)	Mirror
②	Washer	Polyamide	Natural

Item Code	Item Name	L <sub>1</sub>	L <sub>2</sub>	L <sub>3</sub>	D <sub>1</sub>	D <sub>2</sub>	D <sub>3</sub>	D <sub>4</sub>	d	Weight
100-019-893	SRT4-10	10	8	6	14	8	3	10	M4x0.7	7g
100-019-892	SRT4-15	15	8	10	14	8	3	10	M4x0.7	8g
100-019-891	SRT4-20	20	8	12	14	8	3	10	M4x0.7	9g
100-019-890	SRT4-27	27	8	17	14	8	3	10	M4x0.7	10g
100-019-889	SRT5-22	22	8	14	15	8	3.9	10	M5x0.8	11g
100-019-888	SRT5-27	27	8	17	15	8	3.9	10	M5x0.8	12g
100-019-887	SRT5-37	37	8	22	15	8	3.9	10	M5x0.8	13g
100-019-886	SRT6-21	21	9	13	16	8	4.8	10	M6x1	14g
100-019-885	SRT6-26	26	9	16	16	8	4.8	10	M6x1	14g
100-019-884	SRT6-36	36	9	21	18	10	4.8	10	M6x1	20g
100-019-895	SRT6-50	50	9	35	18	10	4.8	10	M6x1	24g
100-019-883	SRT8-34	34	11	19	22	12	5.8	14	M8x1.25	36g
100-019-882	SRT8-44	44	11	24	22	12	5.8	14	M8x1.25	38g
100-019-894	SRT8-50	50	11	35	22	12	5.8	14	M8x1.25	40g

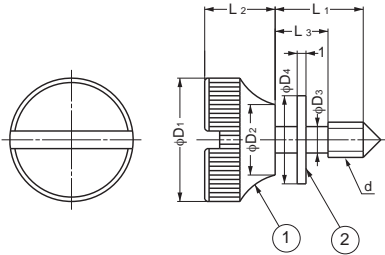

# KNURLED KNOB



# SRT-N

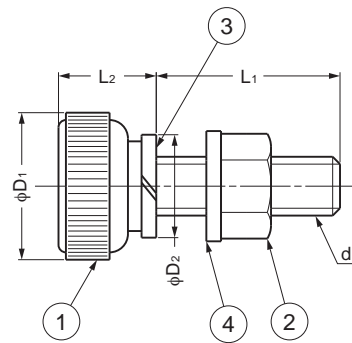

No.	Part Name	Material	Finish
①	Knurled Knob	Stainless Steel (SUS303)	Mirror
②	Hex Nut	Stainless Steel (SUS303)	Clear Zinc Chromate
③	Plate	Stainless Steel (SUS303)	Clear Zinc Chromate
④	Washer	Polyacetal	Natural

Item Code	Item Name	L <sub>1</sub>	L <sub>2</sub>	φD <sub>1</sub>	φD <sub>2</sub>	d	Weight	Box
100-019-842	SRT-N3-20S	20	8	11	8	M3x0.5	6g	500pcs
100-019-841	SRT-N4-20S	20	10	16	11	M4x0.7	15g	300pcs
100-019-843	SRT-N5-20S	20	10	16	11	M5x0.8	16g	-
100-019-138	SRT-N6-25S	25	12	20	14	M6x1	18g	-
100-019-844	SRT-N8-25S	25	12	20	14	M8x1.25	20g	-

# KNURLED KNOB

# BRT-L6

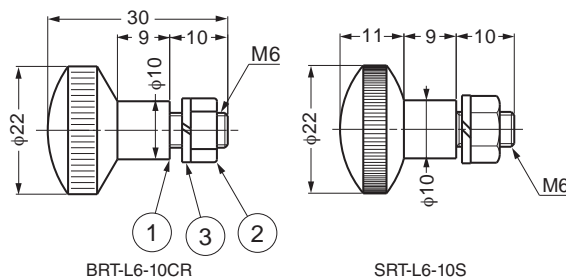
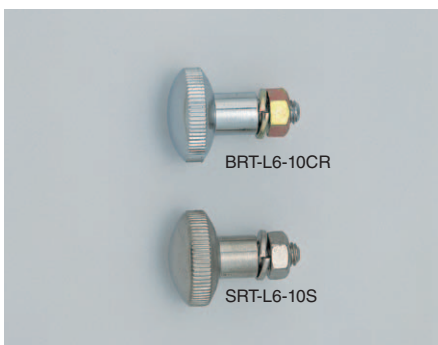

Item Code	Item Name	Material	Finish	Weight	Box
100-019-847	BRT-L6-10CR	Brass & Steel	Chromate & Yellow Zinc Chromate	40g	100pcs
100-010-160	BRT-L6-10S	Stainless Steel	Mirror	40g	100pcs



**BRT**

## KNURLED KNOB



• With fall-preventing washer.

No.	Part Name	Material	Finish
①	Knurled Knob	Brass	Chrome
②	Washer	Polyamide	Natural

Item Code	Item Name	L <sub>1</sub>	L <sub>2</sub>	L <sub>3</sub>	φD <sub>1</sub>	φD <sub>2</sub>	φD <sub>3</sub>	d	Weight
100-019-231	BRT4-10CR	19	8	6	14	8	3	M4×0.7	7g
100-019-244	BRT4-15CR	24.5	8	10	14	8	3	M4×0.7	8g
100-014-070	BRT4-20CR	29.5	8	12	14	8	3	M4×0.7	9g
100-014-069	BRT4-27CR	37	8	17	14	8	3	M4×0.7	10g
100-014-068	BRT5-22CR	32	8	14	15	8	4	M5×0.8	11g
100-014-067	BRT5-27CR	37	8	17	15	8	4	M5×0.8	12g
100-019-809	BRT5-37CR	46.5	8	22	15	8	4	M5×0.8	13g
100-014-065	BRT6-21CR	32	9	13	16	8	4.8	M6×1	14g
100-014-064	BRT6-26CR	36.5	9	16	16	8	4.8	M6×1	14g
100-014-063	BRT6-36CR	47	9	21	18	10	4.8	M6×1	20g
100-014-072	BRT6-50CR	61	9	35	18	10	4.8	M6×1	24g
100-019-805	BRT8-34CR	47.5	11	19	22	12	5.8	M8×1.25	36g
100-014-061	BRT8-44CR	57.5	11	24	22	12	5.8	M8×1.25	38g
100-014-071	BRT8-50CR	63.5	11	35	22	12	5.8	M8×1.25	40g

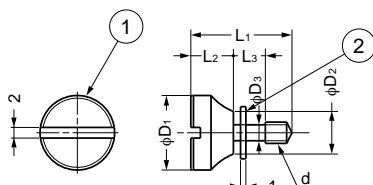

## KNURLED KNOB

**BRT-NB**

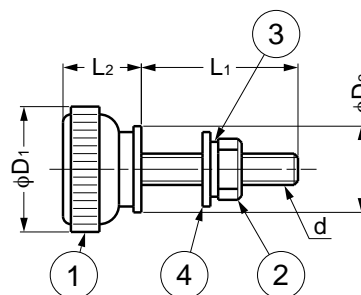

No.	Part Name	Material	Finish
①	Knurled Knob	Brass	Chrome
②	Hex Nut	Brass	Nickel
③	Plate	Bronze	Nickel
④	Washer	Polyacetal	Natural

Item Code	Item Name	L <sub>1</sub>	L <sub>2</sub>	φD <sub>1</sub>	φD <sub>2</sub>	d	Weight	Box
100-019-850	BRT-NB3-20CR	20	8	11	8	M3×0.5	6g	500pcs
100-019-848	BRT-NB4-20CR	20	10	16	11	M4×0.7	15g	300pcs
100-019-851	BRT-NB5-20CR	20	10	16	11	M5×0.8	16g	300pcs
100-019-852	BRT-NB6-25CR	25	12	20	14	M6×1	18g	150pcs
100-019-853	BRT-NB8-25CR	25	12	20	14	M8×1.25	20g	100pcs

## KNURLED KNOB

**BRT-NC**

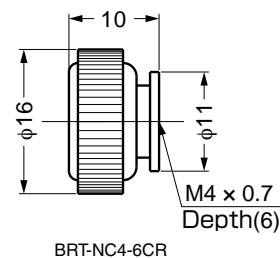
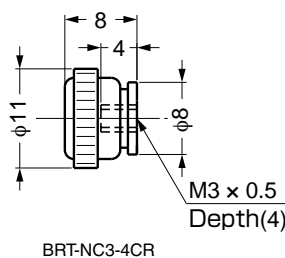

Item Code	Item Name	Material	Finish	Weight	Box
100-019-849	BRT-NC3-4CR	Brass	Chrome	4g	200pcs
100-019-052	BRT-NC4-6CR	Brass	Chrome	12g	500pcs

# KNURLED KNOB

# BRB-A4-15CR, BRF



BRB-A4-15CR

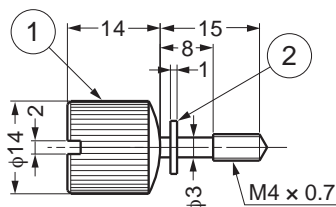

BRF

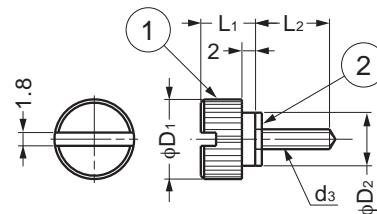

No.	Part Name	Material	Finish
①	Knurled Knob	Brass	Chrome
②	Washer	Polyamide	Natural

Item Code	Item Name	L <sub>1</sub>	L <sub>2</sub>	φD <sub>1</sub>	φD <sub>2</sub>	d <sub>3</sub>	Weight	
100-049-388	BRB-A4-15CR	Refer to the above drawing						19g
100-019-825	BRF-A3-6CR	8	6.5	12	8	M3×0.5	6g	
100-019-824	BRF-A3-10CR	8	10.5	12	8	M3×0.5	7g	
100-019-823	BRF-A4-8CR	10	8	15	10	M4×0.7	13g	
100-019-822	BRF-A4-13CR	10	13	15	10	M4×0.7	14g	
100-019-821	BRF-A5-7CR	10	7.5	15	12	M5×0.8	14g	
100-019-820	BRF-A5-12CR	10	12.5	15	12	M5×0.8	15g	
100-019-819	BRF-A6-7CR	12	7	18	12	M6×1	24g	
100-019-818	BRF-A6-12CR	12	12	18	12	M6×1	25g	

# KNURLED KNOB

# DBN

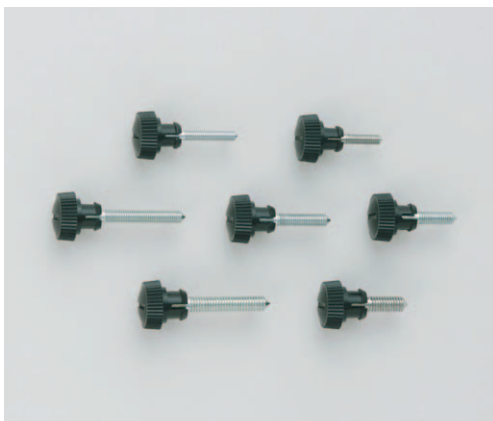

• One-touch installation.

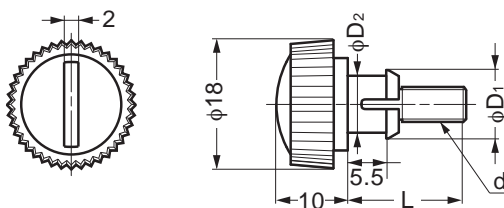

■ Installation

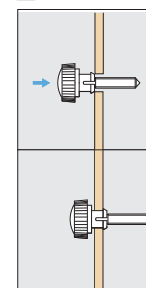

Item Code	Item Name	Material	Finish/Color	L	φD <sub>1</sub>	φD <sub>2</sub>	d	Cut Out Dimensions	Weight	Box
100-011-915	DBN4-21SUS	Stainless Steel, Polyacetal	Plain, Black	22	9.5	8.2	M4	8.5	4.8g	100pcs
100-011-916	DBN4-27SUS	Stainless Steel, Polyacetal	Plain, Black	27	9.5	8.2	M4	8.5	5.3g	100pcs
100-011-917	DBN5-21SUS	Stainless Steel, Polyacetal	Plain, Black	21	10.5	9	M5	9.5	6.4g	100pcs
100-011-918	DBN5-26SUS	Stainless Steel, Polyacetal	Plain, Black	26	10.5	9	M5	9.5	7g	100pcs
100-011-919	DBN5-36SUS	Stainless Steel, Polyacetal	Plain, Black	36	10.5	9	M5	9.5	8.2g	100pcs
100-011-920	DBN6-21SUS	Stainless Steel, Polyacetal	Plain, Black	21	11.5	10	M6	10.5	8.5g	100pcs
100-011-921	DBN6-26SUS	Stainless Steel, Polyacetal	Plain, Black	26	11.5	10	M6	10.5	9.3g	100pcs
100-011-922	DBN6-36SUS	Stainless Steel, Polyacetal	Plain, Black	36	11.5	10	M6	10.5	11g	100pcs
100-011-907	DBN4-21	Steel, Polyacetal	Clear Zinc Chromate, Black	22	9.5	8.2	M4	8.5	4.5g	100pcs
100-011-908	DBN4-27	Steel, Polyacetal	Clear Zinc Chromate, Black	27	9.5	8.2	M4	8.5	5.2g	100pcs
100-011-909	DBN5-21	Steel, Polyacetal	Clear Zinc Chromate, Black	21	10.5	9	M5	9.5	6.4g	100pcs
100-011-910	DBN5-26	Steel, Polyacetal	Clear Zinc Chromate, Black	26	10.5	9	M5	9.5	6.4g	100pcs
100-011-911	DBN5-36	Steel, Polyacetal	Clear Zinc Chromate, Black	36	10.5	9	M5	9.5	8.1g	100pcs
100-011-912	DBN6-21	Steel, Polyacetal	Clear Zinc Chromate, Black	21	11.5	10	M6	10.5	8.4g	100pcs
100-011-913	DBN6-26	Steel, Polyacetal	Clear Zinc Chromate, Black	26	11.5	10	M6	10.5	9.2g	100pcs
100-011-914	DBN6-36	Steel, Polyacetal	Clear Zinc Chromate, Black	36	11.5	10	M6	10.5	11g	100pcs



CASTERS

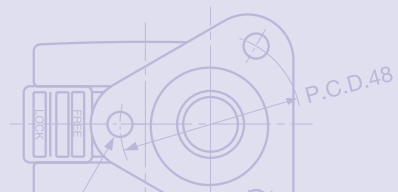

CASTERS

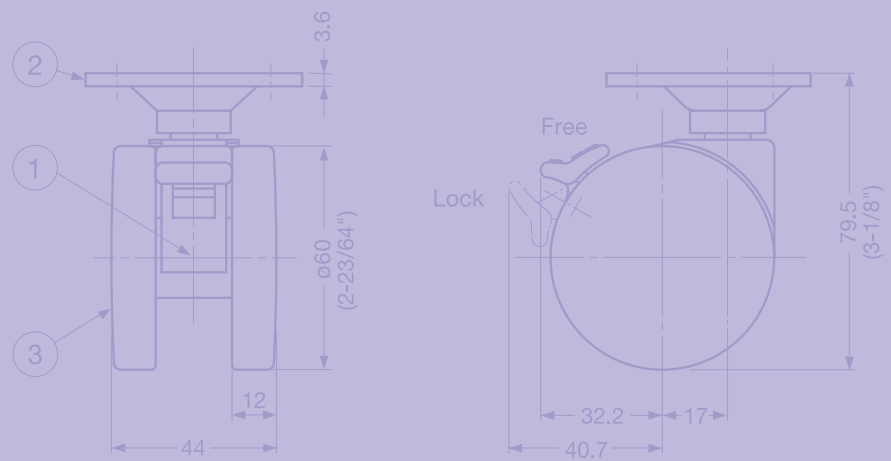

**SHOCK ABSORBING CASTERS**

Picture	Item Name	Load Capacity (kgf)	Wheel Diameter	Page
	TP-LF, TPAH-LF	100 - 900	151 - 201.5	392
	TP-LC, TPAH-LC	100 - 900	151 - 201.5	393
	NPG	30.6	100 - 125	394
	NPR	30.6	100 - 125	395
	NPT	30.6	100 - 125	395
	CUJ-200	204	200	398
	CUK-200	204	200	398

**DUAL BRAKE SYSTEM CASTERS**

Picture	Item Name	Load Capacity (kgf)	Wheel Diameter	Page
	MX-125PS, P	120	125	396
	MX-125N	120	125	396
	EX-100PS, P	100	100	397
	EX-100N	100	100	397

**CASTER WITH LEVELING GLIDES**

Picture	Item Name	Load Capacity (kgf)	Wheel Diameter	Page
	CA	60 -120	50 - 75	399
	AF	255	50 - 65	400

**LOW PROFILE HEAVY DUTY CASTERS**

Picture	Item Name	Load Capacity (kgf)	Wheel Diameter	Page
	UHG	408 - 816	50 - 100	400
	UHGK	408 - 612	50 - 75	401
	HG	163 - 306	50 - 75	401
	HR	163 - 306	50 - 75	402
	HT-65PB	204	65	402
	TSG	120 - 300	50 - 75	403
	TSR	120 - 300	50 - 75	403

**STAINLESS STEEL CASTERS**

Picture	Item Name	Load Capacity (kgf)	Wheel Diameter	Page
	SUS-SJ	50 - 150	65 - 125	404
	SUS-SK	50 - 160	65 - 150	405
	SUS-E	40 - 61	50 - 100	406
	SUS-ER	40 - 61	50 - 100	406
	SUS-ET	30 - 61	50 - 100	407

**GENERAL INDUSTRIAL CASTERS**

Picture	Item Name	Load Capacity (kgf)	Wheel Diameter	Page
	TSG	20 - 60	40 - 100	408
	TSR	20 - 60	40 - 100	408



**TWIN SHEEL CASTERS**

Picture	Item Name	Load Capacity (kgf)	Wheel Diameter	Page
	GX-75-PS, P	200	75	409
	GX-75-N16S, N16	200	75	409
	GX-60-PS, P	150	60	410
	GX-60-N12S, N12	150	60	410
	GX-50-PS, P	100	50	411
	GX-50-N12S, N12	100	50	411
	GX-W50GP	200	50	412
	GX-W50GN	200	50	412
	GX-W50K	200	50	413
	T, TSD	80 - 100	76 - 100	413
	T, TSD	80 - 100	76 - 100	413
	FAU55PS, P	70	53	414
	FAU55N	70	53	414
	FPU55PS, P	50	53	415
	FPU55NS, N	50	53	415
	FA55PS, P	80	53	416
	FA55N	80	53	416
	FP55PS, P	50	53	417
	FP55N	50	53	417
	FA45PS, P	50	47	418
	FA45NS, N	50	47	418
	FA55-FIX	-	-	419
	FP45PS, P	40	47	419
	FP45NS, N	40	47	419

**BALL CASTERS**

Picture	Item Name	Load Capacity (kgf)	Wheel Diameter	Page
	BM	10 - 40	-	420
	BH	10 - 20	-	420
	BHB-12	8	-	420
	NT	25	-	420
	NS	25	-	420

**BASE**

Picture	Item Name	Pipe Φ	Page
	HS-550	38	421
	HO500	50.8	422
	BJ610	50.8	423

# SHOCK-ABSORBING CASTER

LOAD CAPACITY  
100-900 kgf

# TP-LF, TPAH-LF



- Built-in shock absorber provides less vibration and noise.
- Swivel type.

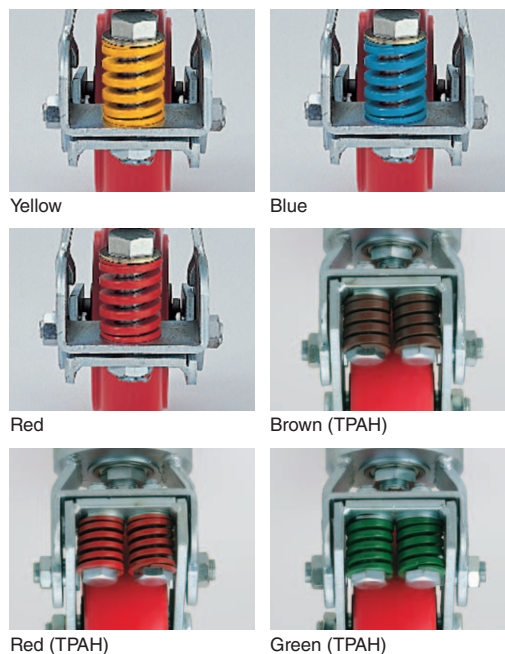

### TP-150LF

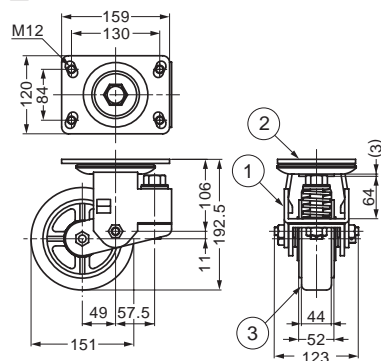

### TP-200LF

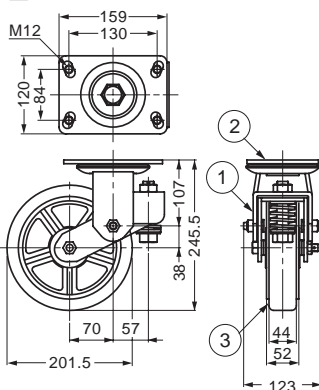

### TPAH-200LF

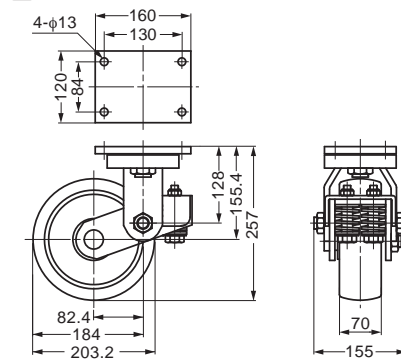

### Application

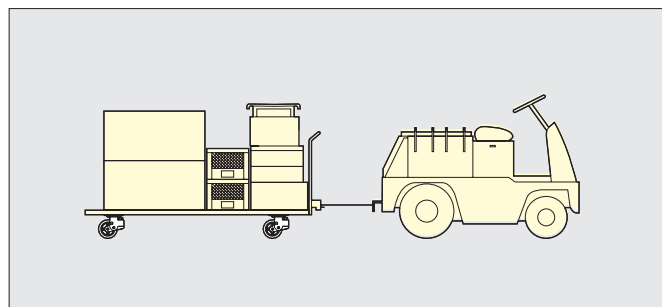

No.	Part Name	Material	Finish/Color
①	Body	Steel	Clear Zinc Chromate
②	Plate	Steel	Clear Zinc Chromate
③	Wheel	Polyurethane	Red

Item Code	Item Name	Wheel dia.	Spring Color	Load Capacity (pc)		Weight	Box
200-130-714	TP-150LF-A-YE	151	Yellow	980N	100kgf	5.1kg	4pcs
200-130-715	TP-150LF-A-BU	151	Blue	2,116N	216kgf	5.1kg	4pcs
200-130-716	TP-150LF-A-RD	151	Red	3,136N	320kgf	5.1kg	4pcs
200-130-717	TP-200LF-A-YE	201.5	Yellow	980N	100kgf	6.7kg	2pcs
200-130-718	TP-200LF-A-BU	201.5	Blue	2,116N	216kgf	6.7kg	2pcs
200-130-719	TP-200LF-A-RD	201.5	Red	3,136N	320kgf	6.7kg	2pcs
200-012-504	TPAH-200LF-A-RD	203.2	Red	4,900N	500kgf	15kg	1pcs
200-012-505	TPAH-200LF-A-GN	203.2	Green	7,056N	720kgf	15kg	1pcs
200-012-506	TPAH-200LF-A-BR	203.2	Brown	8,820N	900kgf	15kg	1pcs

TPAH is special order.

# SHOCK-ABSORBING CASTER

LOAD CAPACITY  
100-900 kgf

# TP-LC, TPAH-LC



- Built-in shock absorber provides less vibration and noise.
- Non-swivel type.

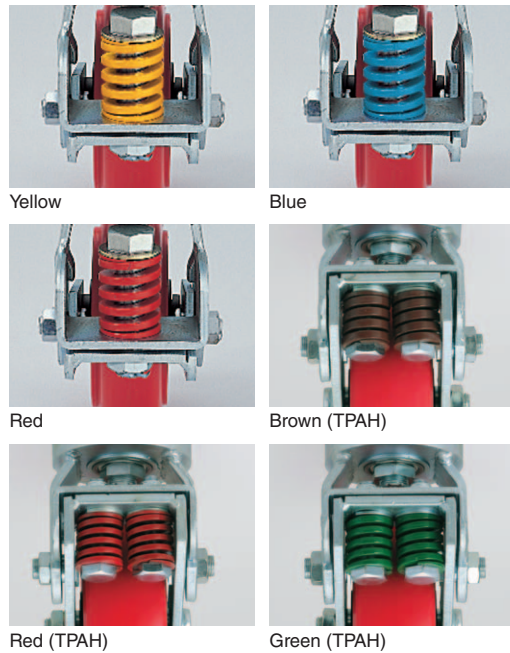

### TP-150LC

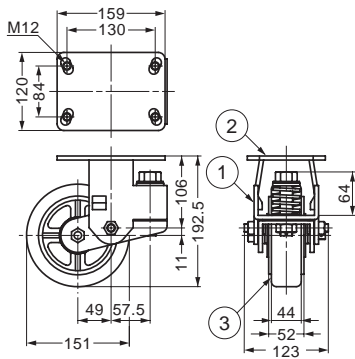

### TP-200LC

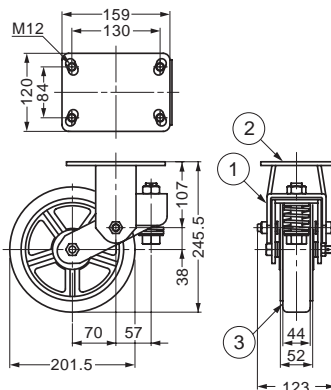

### TPAH-200LC

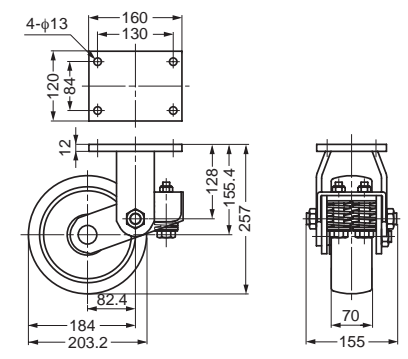

### Application

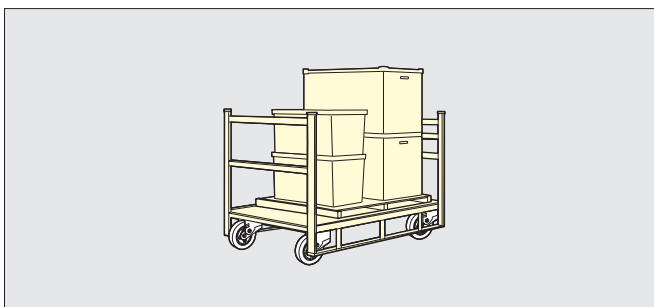

No.	Part Name	Material	Finish/Color
①	Body	Steel	Clear Zinc Chromate
②	Plate	Steel	Clear Zinc Chromate
③	Wheel	Polyurethane	Red

Item Code	Item Name	Wheel dia.	Spring Color	Load Capacity (pc)		Weight	Box
200-130-720	TP-150LC-A-YE	151	Yellow	980N	100kgf	5.1kg	4pcs
200-130-721	TP-150LC-A-BU	151	Blue	2,116N	216kgf	5.1kg	4pcs
200-130-722	TP-150LC-A-RD	151	Red	3,136N	320kgf	5.1kg	4pcs
200-130-723	TP-200LC-A-YE	201.5	Yellow	980N	100kgf	6.7kg	2pcs
200-130-724	TP-200LC-A-BU	201.5	Blue	2,116N	216kgf	6.7kg	2pcs
200-130-725	TP-200LC-A-RD	201.5	Red	3,136N	320kgf	6.7kg	2pcs
200-012-507	TPAH-200LC-A-RD	203.2	Red	4,900N	500kgf	13.5kg	1pcs
200-012-508	TPAH-200LC-A-GN	203.2	Green	7,056N	720kgf	13.5kg	1pcs
200-012-509	TPAH-200LC-A-BR	203.2	Brown	8,820N	900kgf	13.5kg	1pcs

TPAH is special order.

# SHOCK-ABSORBING CASTER

Shock absorber reduces initial shock and also settles vibration quickly. With less shock and vibration, it reduces particles which causes air contamination up to 85%, compared to non-damping casters.

## Shock Absorbing Performance

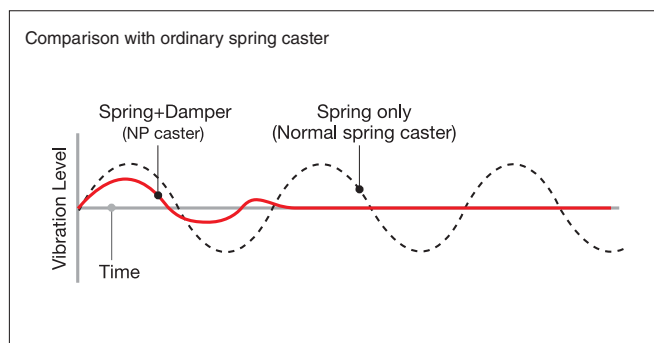
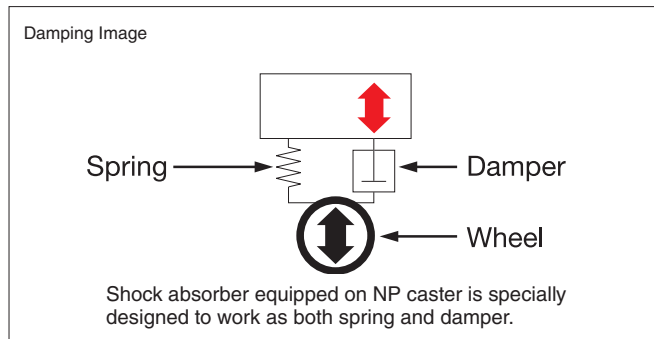

## Shock Absorbing Damper

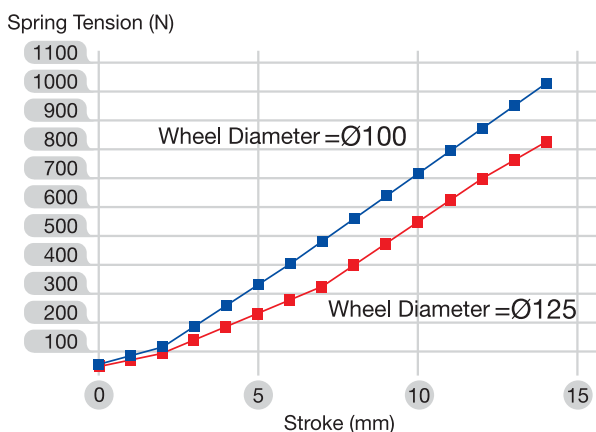
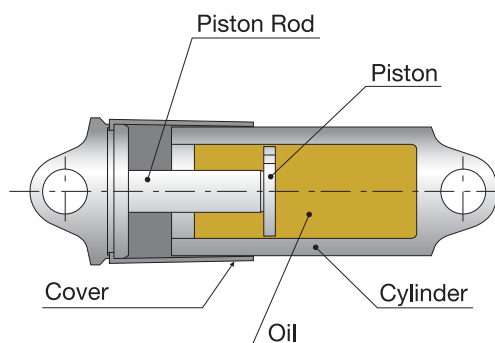

# SHOCK-ABSORBING CASTER (PLATE TYPE)

LOAD CAPACITY  
30 kgf

STAINLESS  
304  
STEEL

NPG

Discontinued



- Swivel type.
- Built-in shock absorber reduces vibration and noise.
- Ideal for carts which carry delicate products such as electronic instruments.
- Stainless steel construction with antistatic polyurethane wheel, ideal for clean room applications.
- Insulation resistance value:  $4.8 \times 10^8$
- Operating temperature: 10°C~30°C
- Available option (special order): Steel body, wheel in Nylon or Polyurethane.

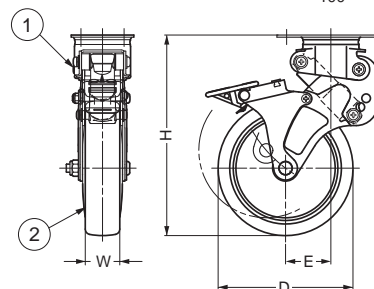
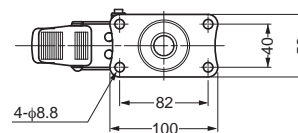

No.	Part Name	Material	Finish
①	Body	Stainless Steel	Plain
②	Wheel	Urethane	Yellow

Item Code	Item Name	Spec.	D	W	H	E	Load Capacity(pc)	Weight	Carton
200-130-582	NPG-100SUES-3	With Brake	100	28	165~150	35~51	300N	30.6kgf	935g 20pcs
200-130-581	NPG-100SUE-3	Without Brake	100	28	165~150	35~51	300N	30.6kgf	860g 25pcs
200-130-588	NPG-125SUES-3	With Brake	125	32	186~170	42~59	300N	30.6kgf	1065g 15pcs
200-130-587	NPG-125SUE-3	Without Brake	125	32	186~170	42~59	300N	30.6kgf	920g 20pcs

# SHOCK-ABSORBING CASTER (RIGID TYPE)

LOAD CAPACITY  
30 kgf

STAINLESS  
304  
STEEL

NPR

**Discontinued**



- Non-swivel (Rigid) type.
- Built-in shock absorber reduces vibration and noise.
- Ideal for carts which carry delicate products such as electronic instruments.
- Stainless steel construction with antistatic polyurethane wheel, ideal for clean room applications.
- Insulation resistance value:  $4.8 \times 10^8$
- Operating temperature:  $10^{\circ}\text{C} \sim 30^{\circ}\text{C}$
- Available option (special order): Steel body, wheel in Nylon, or Polyurethane.

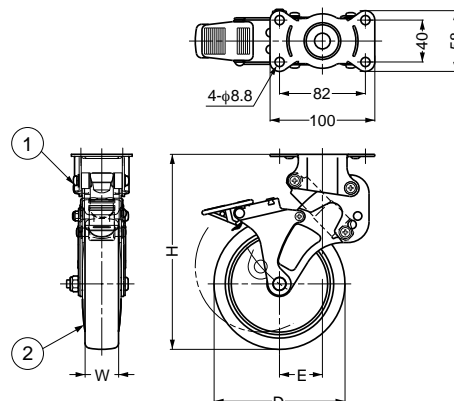

No.	Part Name	Material	Finish
①	Body	Stainless Steel	Plain
②	Wheel	Urethane	Yellow

Item Code	Item Name	Spec.	D	W	H	E	Load Capacity(pc)	Weight	Carton
200-130-584	NPR-100SUES-3	With Brake	100	28	165~150	35~51	300N 30.6kgf	795g	20pcs
200-130-583	NPR-100SUE-3	Without Brake	100	28	165~150	35~51	300N 30.6kgf	720g	25pcs
200-130-590	NPR-125SUES-3	With Brake	125	32	186~170	42~59	300N 30.6kgf	905g	15pcs
200-130-589	NPR-125SUE-3	Without Brake	125	32	186~170	42~59	300N 30.6kgf	760g	20pcs

# SHOCK-ABSORBING CASTER (THREADED BOLT TYPE)

LOAD CAPACITY  
30 kgf

STAINLESS  
304  
STEEL

NPT

**Discontinued**



- Built-in shock absorber reduces vibration and noise.
- Ideal for carts which carry delicate products such as electronic instruments.
- Stainless steel construction with antistatic polyurethane wheel, ideal for clean room applications.
- Insulation resistance value:  $4.8 \times 10^8$
- Operating temperature:  $10^{\circ}\text{C} \sim 30^{\circ}\text{C}$
- Available option (special order): Steel body, wheel in Nylon, or Polyurethane.

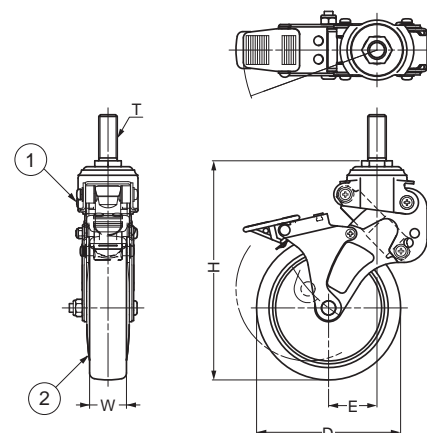

No.	Part Name	Material	Finish
①	Body	Stainless Steel	Plain
②	Wheel	Urethane	Yellow

Item Code	Item Name	Spec.	D	W	T	H	E	Load Capacity(pc)	Weight	Carton
200-130-586	NPT-100SUES-3	With Brake	100	28	M12×35	169~154	35~51	300N 30.6kgf	940g	20pcs
200-130-585	NPT-100SUE-3	Without Brake	100	28	M12×35	169~154	35~51	300N 30.6kgf	865g	25pcs
200-130-592	NPT-125SUES-3	With Brake	125	32	M16×40	190~174	42~59	300N 30.6kgf	1050g	15pcs
200-130-591	NPT-125SUE-3	Without Brake	125	32	M16×40	190~174	42~59	300N 30.6kgf	905g	20pcs

## DUAL BRAKE SYSTEM CASTER (PLATE TYPE)



LOAD CAPACITY  
120 kgf

### MX-125PS, P

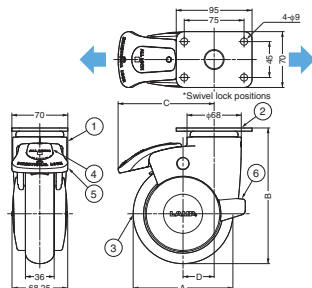

- Unique dual brake system:
  - Can be locked on "swivel only" or "wheel and swivel" in one step.
  - Large lock lever for swivel, and small lock lever for wheel.
- Works as rigid type when swivel locked for easy movability.
- Easy operation.

No.	Part Name	Material	Finish/Color
①	Body	Polypropylene	Light Grey
②	Plate	Steel	Chromate
③	Wheel	Polyamide/Polyurethane	Dark Grey
④	Brake	Polyamide	Blue
⑤	Brake	Polyamide	Light Blue
⑥	Rear Bumper	Polyurethane	Dark Grey

Item Code	Item Name	Spec.	A	B	C	D	Load Capacity(pc)	Box
200-130-053	MX-125PS	With Brake	125	170	120.5	39	1176N	120kgf 2pcs
200-130-052	MX-125P	Without Brake	125	170	101.5	39	1176N	120kgf 2pcs

## DUAL BRAKE SYSTEM CASTER (THREADED BOLT TYPE)



LOAD CAPACITY  
120 kgf

### MX-125N

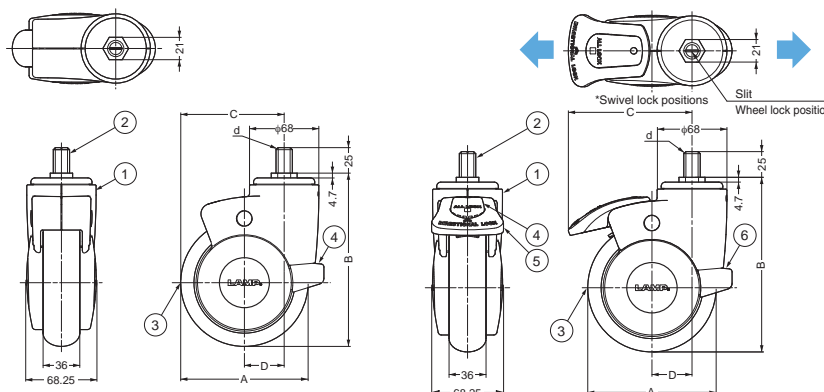

- Unique dual brake system:
  - Can be locked on "swivel only" or "wheel and swivel" in one step.
  - Large lock lever for swivel, and small lock lever for wheel.
- Works as rigid type when swivel locked for easy movability.
- Easy operation.

No.	Part Name	Material	Finish/Color
①	Body	Polypropylene	Light Grey
②	Threaded Bolt	Steel	Chromate
③	Wheel	Polyamide/Polyurethane	Dark Grey
④	Rear Bumper	Polyurethane	Dark Grey

No.	Part Name	Material	Finish/Color
①	Body	Polypropylene	Light Grey
②	Threaded Bolt	Steel	Chromate
③	Wheel	Polyamide/Polyurethane	Dark Grey
④	Brake	Polyamide	Blue
⑤	Brake	Polyamide	Light Blue
⑥	Rear Bumper	Polyurethane	Dark Grey

### Application

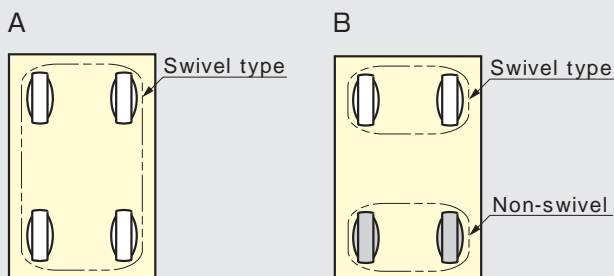

A | Easy to manoeuvre in limited space.

B | Use of swivel caster towards the handles for easy and smooth operation.

Item Code	Item Name	Spec.	A	B	C	D	d	Load Capacity(pc)	Box
200-130-055	MX-125N16S	With Brake	125	170	120.5	39	M16	1176N 120kgf	2pcs
200-130-054	MX-125N16	Without Brake	125	170	101.5	39	M16	1176N 120kgf	2pcs

## DUAL BRAKE SYSTEM CASTER (PLATE TYPE)

TEST

LOAD CAPACITY  
100 kgf

## EX-100PS, P



- Locks both wheel and swivel.
- Ball bearing equipped in both swivel and wheel to provide maximum smooth movements.
- Front rubber bumper offer protection from impact.
- Large brake lever and indicator for easy operation.

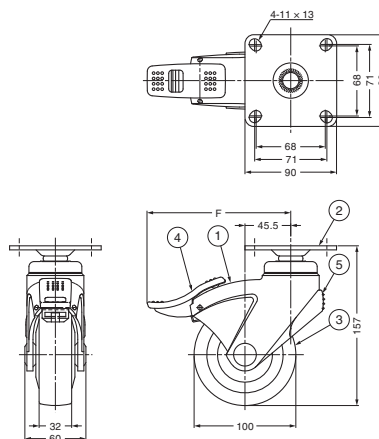

No.	Part Name	Material	Finish/Color
①	Body	Reinforced Nylon	Light Grey
②	Plate	Steel	Yellow Zinc Chromate
③	Wheel	Polyamide/Polyurethane	Grey
④	Brake	Reinforced Nylon	Grey
⑤	Rear Bumper	Synthetic Rubber	Grey

Item Code	Item Name	Spec	F	Load Capacity(pc)	Box
200-132-735	EX-100PS	With Brake	(139)	980N 100kgf	20pcs
200-132-734	EX-100P	Without Brake	(105)	980N 100kgf	20pcs

## DUAL BRAKE SYSTEM CASTER (THREADED BOLT TYPE)

TEST

LOAD CAPACITY  
100 kgf

## EX-100N



- Locks both wheel and swivel.
- Ball bearing equipped in both swivel and wheel to provide maximum smooth movements.
- Front rubber bumper offer protection from impact.
- Large brake lever and indicator for easy operation.

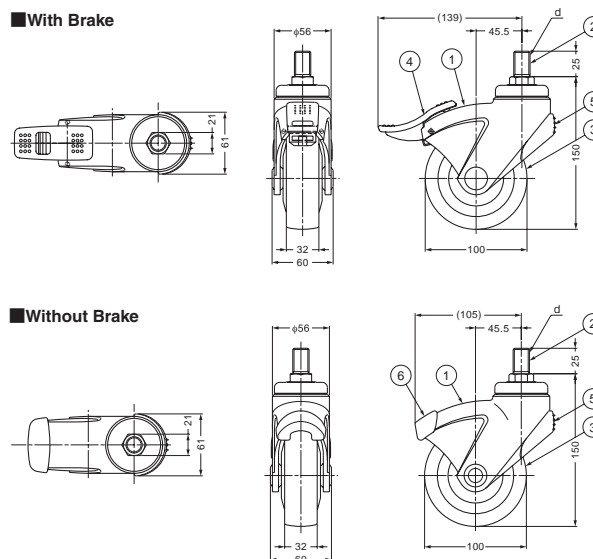

No.	Part Name	Material	Finish/Color
①	Body	Reinforced Nylon	Light Grey
②	Threaded Bolt	Steel	Yellow Zinc Chromate
③	Wheel	Polyamide/Polyurethane	Grey
④	Brake	Reinforced Nylon	Grey
⑤	Rear Bumper	Synthetic Rubber	Grey
⑥	Front Bumper	Synthetic Rubber	Grey

Item Code	Item Name	Spec	d	Load Capacity(pc)	Box
200-132-736	EX-100N12S	With Brake	M12x1.75	980N 100kgf	20pcs
200-132-730	EX-100N12	Without Brake	M12x1.75	980N 100kgf	20pcs
200-132-733	EX-100N16S	With Brake	M16x2	980N 100kgf	20pcs
200-132-732	EX-100N16	Without Brake	M16x2	980N 100kgf	20pcs

# SHOCK-ABSORBING CASTER (PLATE TYPE)

LOAD CAPACITY  
102~204 kgf

## CUJ-200

Discontinued



- Swivel type
- Built-in shock absorber reduces vibration and noise
- Sealed heavy duty ball bearing provides smooth movement
- Available option (special order): with brake

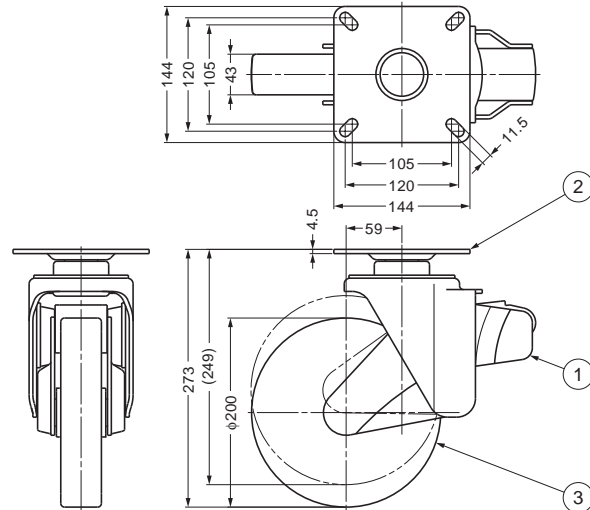

No.	Part Name	Material	Finish/Color
①	Body	Steel	Clear Zinc Chromate
②	Plate	Steel	Clear Zinc Chromate
③	Wheel	Rubber	Black

Item Code	Item Name	Load Capacity(pc)	Weight	Box
200-014-082	CUJ-200WF	1000~2000N	102~204kgf	6.9kg 2pcs
200-021-999	CUJ-200UWF	1000~2000N	102~204kgf	7.1kg 2pcs

# SHOCK-ABSORBING CASTER

LOAD CAPACITY  
102~204 kgf

## CUK-200

Discontinued



- Non-swivel (Rigid) type
- Built-in shock absorber reduces vibration and noise
- Sealed heavy duty ball bearing provides smooth movement

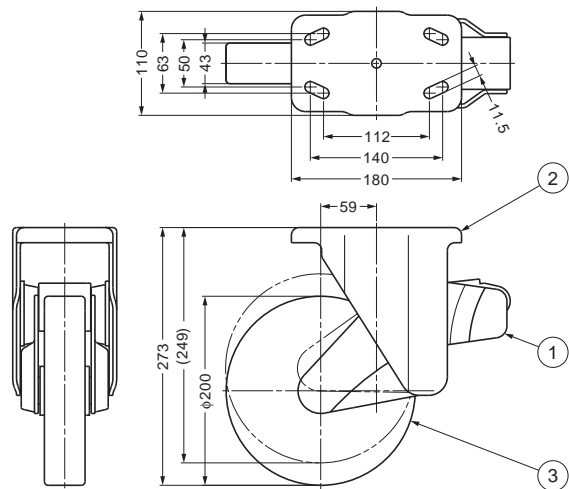

No.	Part Name	Material	Finish/Color
①	Body	Steel	Clear Zinc Chromate
②	Plate	Steel	Clear Zinc Chromate
③	Wheel	Rubber	Black

Item Code	Item Name	Load Capacity(pc)	Weight	Box
200-014-081	CUK-200WF	1000~2000N	102~204kgf	5.8kg 2pcs
200-021-998	CUK-200UWF	1000~2000N	102~204kgf	6.0kg 2pcs



# PARTS SEPARABLE CASTER (W/GLIDE)

LOAD CAPACITY  
60-120 kgf

STAINLESS  
304  
STEEL

CA



- Caster with Built-in leveling glide.
- Glides provide better stability than a regular caster with stopper.
- Caster body rotates freely when raised by the glide. Tighten fixing screw to fix the position.
- Parts can be easily separated for recycling purpose.

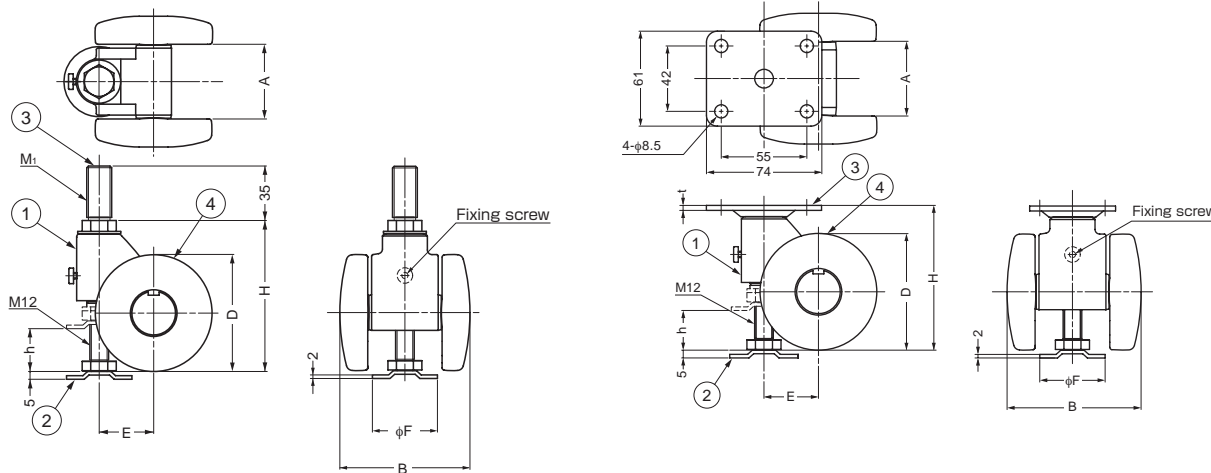

No.	Part Name	Material	Finish/Color
①	Body	Polyamide	Black (B)/White (W)
②	Adjuster	Steel	Yellow Zinc Chromate
		Stainless Steel (SUS304)	Passivation
③	Plate/Threaded Bolt	Steel	Yellow Zinc Chromate
		Stainless Steel (SUS304)	Passivation
④	Wheel	Polyamide/Synthetic Rubber	Black (B)/a (W)

## ■ Plate Type

Item Code	Item Name	Material	Finish/Color	D	H	h	E	F	A	B	t	Load Capacity(pc)	Weight	Box	
200-130-238	CAPF50B	Steel,Polyamide	Yellow Zinc Chromate,Black	50	63	10	30	34	40	70	3.2	588N	60kgf	306g	40pcs
200-130-239	CAPF50W	Steel,Polyamide	Yellow Zinc Chromate,White	50	63	10	30	34	40	70	3.2	588N	60kgf	306g	40pcs
200-130-808	CAPF50UB	Steel,Synthetic Rubber	Yellow Zinc Chromate,Black	50	63	10	30	34	40	70	3.2	588N	60kgf	300g	40pcs
200-130-809	CAPF50UW	Steel,Synthetic Rubber	Yellow Zinc Chromate,White	50	63	10	30	34	40	70	3.2	588N	60kgf	300g	40pcs
200-130-240	CAPF75B	Steel,Polyamide	Yellow Zinc Chromate,Black	75	92	24	35	42	50	85	3.2	1176N	120kgf	424g	20pcs
200-130-241	CAPF75W	Steel,Polyamide	Yellow Zinc Chromate,White	75	92	24	35	42	50	85	3.2	1176N	120kgf	424g	20pcs
200-130-810	CAPF75UB	Steel,Synthetic Rubber	Yellow Zinc Chromate,Black	75	92	24	35	42	50	85	3.2	1176N	120kgf	460g	20pcs
200-130-811	CAPF75UW	Steel,Synthetic Rubber	Yellow Zinc Chromate,White	75	92	24	35	42	50	85	3.2	1176N	120kgf	460g	20pcs
200-130-250	CAPS50W	Stainless Steel,Polyamide	Passivation,White	50	63	10	30	34	40	70	3	588N	60kgf	300g	40pcs
200-130-820	CAPS50UW	Stainless Steel,Synthetic Rubber	Passivation,White	50	63	10	30	34	40	70	3	588N	60kgf	300g	40pcs
200-130-251	CAPS75W	Stainless Steel,Polyamide	Passivation,White	75	92	24	35	42	50	85	3	1176N	120kgf	420g	20pcs
200-130-821	CAPS75UW	Stainless Steel,Synthetic Rubber	Passivation,White	75	92	24	35	42	50	85	3	1176N	120kgf	460g	20pcs

## ■ Threaded Bolt Type

Item Code	Item Name	Material	Finish/Color	D	H	h	E	F	A	B	M <sub>1</sub>	Load Capacity(pc)	Weight	Box	
200-130-230	CABF50B	Steel,Polyamide	Yellow Zinc Chromate,Black	50	67	10	30	34	40	70	M12	588N	60kgf	260g	40pcs
200-130-231	CABF50W	Steel,Polyamide	Yellow Zinc Chromate,White	50	67	10	30	34	40	70	M12	588N	60kgf	260g	40pcs
200-130-800	CABF50UB	Steel,Synthetic Rubber	Yellow Zinc Chromate,Black	50	67	10	30	34	40	70	M12	588N	60kgf	260g	40pcs
200-130-801	CABF50UW	Steel,Synthetic Rubber	Yellow Zinc Chromate,White	50	67	10	30	34	40	70	M12	588N	60kgf	260g	40pcs
200-130-232	CABF75B	Steel,Polyamide	Yellow Zinc Chromate,Black	75	96	24	35	42	50	85	M16	1176N	120kgf	400g	20pcs
200-130-233	CABF75W	Steel,Polyamide	Yellow Zinc Chromate,White	75	96	24	35	42	50	85	M16	1176N	120kgf	400g	20pcs
200-130-802	CABF75UB	Steel,Synthetic Rubber	Yellow Zinc Chromate,Black	75	96	24	35	42	50	85	M16	1176N	120kgf	430g	20pcs
200-130-803	CABF75UW	Steel,Synthetic Rubber	Yellow Zinc Chromate,White	75	96	24	35	42	50	85	M16	1176N	120kgf	430g	20pcs
200-130-246	CABS50W	Stainless Steel,Polyamide	Passivation,White	50	67	10	30	34	40	70	M12	588N	60kgf	262g	40pcs
200-130-816	CABS50UW	Stainless Steel,Synthetic Rubber	Passivation,White	50	67	10	30	34	40	70	M12	588N	60kgf	230g	40pcs
200-130-247	CABS75W	Stainless Steel,Polyamide	Passivation,White	75	96	24	35	42	50	85	M16	1176N	120kgf	402g	20pcs
200-130-817	CABS75UW	Stainless Steel,Synthetic Rubber	Passivation,White	75	96	24	35	42	50	85	M16	1176N	120kgf	430g	20pcs

# CASTER WITH LEVELING GLIDE



AF



- Heavy duty, low profile caster with integrated leveling glide.
- Allows solid support by leveler once equipment is in place.

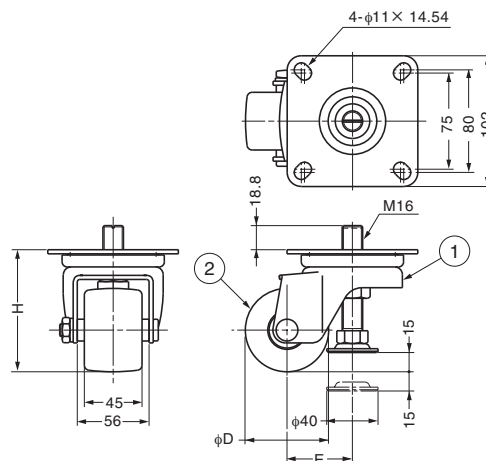

No.	Part Name	Material	Finish/Color
①	Body	Steel	Clear Zinc Chromate
②	Wheel	Reinforced Nylon	Black

Item Code	Item Name	D	H	E	Swivel Radius	Load Capacity(pc)	Weight	Box
200-130-390	AF-50	50	74	46	73	2500N 255kgf	1190g	18pcs
200-130-391	AF-65	65	95	51	84	2500N 255kgf	1320g	12pcs

# LOW PROFILE HEAVY DUTY CASTER



UHG



- Low profile and heavy duty up to 816kg, ideal for manufacturing equipment.
- Sealed heavy duty ball bearing swivel assembly provides smooth and long-term service.
- Hexavalent chromium free. Using trivalent chromium for RoHS compliance.
- Optional wheel types: Phenolic, Reinforced Nylon, MC Nylon or Electro-conductive MC Nylon.

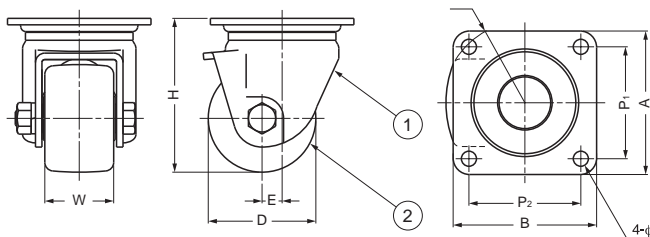

No.	Part Name	Material	Finish/Color
①	Body	Steel	Clear Zinc Chromate
②	Wheel	PB/Phenolic Resin	Black
		GFB/Reinforced Nylon	Black
		MC Nylon	Blue
		MCE/Electro-conductive MC Nylon	Black

Item Code	Item Name	Wheel Material	D	H	E	W	A	B	P <sub>1</sub>	P <sub>2</sub>	d	Swivel Radius	Load Capacity(pc)	Box
200-130-840	UHG-50-PB	Phenolic Resin	50	79	12	38	84	84	64	64	8.5	49	4000N 408kgf	20pcs
200-130-290	UHG-50-MC	MCPolyamide	50	79	12	38	84	84	64	64	8.5	49	4000N 408kgf	20pcs
200-130-291	UHG-50-MCE	Electro-conductive MC Nylon	50	79	12	38	84	84	64	64	8.5	49	4000N 408kgf	20pcs
200-130-841	UHG-65-PB	Phenolic Resin	65	97	14	48	100	100	78	78	10.5	57	5000N 510kgf	12pcs
200-130-292	UHG-65-GFB	Reinforced Nylon	65	97	14	48	100	100	78	78	10.5	57	4000N 408kgf	12pcs
200-130-293	UHG-65-MC	MCPolyamide	65	97	14	48	100	100	78	78	10.5	57	6000N 612kgf	12pcs
200-130-294	UHG-65-MCE	Electro-conductive MC Nylon	65	97	14	48	100	100	78	78	10.5	57	6000N 612kgf	12pcs
200-130-842	UHG-75-PB	Phenolic Resin	75	107	14	48	100	100	78	78	10.5	57	6000N 612kgf	12pcs
200-130-295	UHG-75-GFB	Reinforced Nylon	75	107	14	48	100	100	78	78	10.5	57	5000N 510kgf	12pcs
200-130-296	UHG-75-MC	MCPolyamide	75	107	14	48	100	100	78	78	10.5	57	7000N 714kgf	12pcs
200-130-297	UHG-75-MCE	Electro-conductive MC Nylon	75	107	14	48	100	100	78	78	10.5	57	7000N 714kgf	12pcs
200-130-298	UHG-80-MC	MCPolyamide	80	120	20	48	100	85	80	60	9.0	62	8000N 816kgf	12pcs
200-139-432	UHG-100-MC	MCPolyamide	100	140	20	48	150	110	121	59	13.0	72	8000N 816kgf	8pcs

# LOW PROFILE HEAVY DUTY CASTER

LOAD CAPACITY  
408-612 kgf

UHGK



- Low profile and heavy duty up to 612kg (1346 lbs), ideal for manufacturing equipment.
- Sealed heavy duty ball bearing swivel assembly provides smooth and long-term service.
- Swivel Lock provides easy handling.
- Pull the lever up for rigid caster use, push down the lever for swivel caster use.
- Hexavalent chromium free. Using trivalent chromium for RoHS compliance.
- Optional wheel types from: Phenolic, MC Nylon or Electro-conductive MC Nylon.

\*Please specify wheel type when ordering.

Part Name	Material	Finish
Body / Mounting Plate	Steel	Clear Zinc Chromate (Trivalent Chromium)
Wheel	Phenolic Resin (PB)	Black
	MC Nylon (MC)	
	Electro-conductive MC Nylon (MCE)	

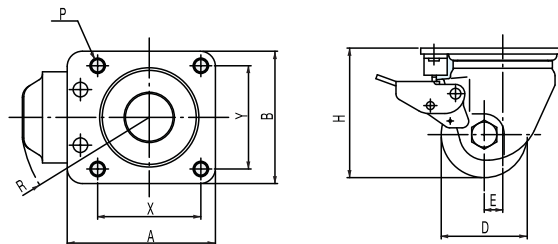

Item Code	Item Name	D	Wheel Width	H	A	B	X	Y	P	E	Swivel Radius	Load Capacity (pc)	Weight	Box	Carton
200-139-543	UHGK-50PB	50	38	79	96	84	64	64	8.5	12	83	408kg	822g	20pcs	200pcs
200-139-544	UHGK-50MC	50	38	79	96	84	64	64	8.5	12	83	408kg	818g	20pcs	200pcs
200-139-545	UHGK-50MCE	50	38	79	96	84	64	64	8.5	12	83	408kg	824g	20pcs	200pcs
200-139-546	UHGK-65PB	65	48	97	112	100	78	78	10.5	14	98	510kg	1559g	12pcs	120pcs
200-139-547	UHGK-65MC	65	48	97	112	100	78	78	10.5	14	98	510kg	1540g	12pcs	120pcs
200-139-548	UHGK-65MCE	65	48	97	112	100	78	78	10.5	14	98	510kg	1549g	12pcs	120pcs
200-139-549	UHGK-75PB	75	48	107	112	100	78	78	10.5	14	98	612kg	1660g	12pcs	120pcs
200-139-550	UHGK-75MC	75	48	107	112	100	78	78	10.5	14	98	612kg	1644g	12pcs	120pcs
200-139-551	UHGK-75MCE	75	48	107	112	100	78	78	10.5	14	98	612kg	1641g	12pcs	120pcs

# LOW PROFILE HEAVY DUTY CASTER

LOAD CAPACITY  
163.2-326 kgf

HG



- Low profile and heavy duty up to 255kg, ideal for manufacturing equipment.
- Hardened frame for maximum rigidity and strength.
- Sealed ball bearing swivel assembly provides smooth and long-term service.
- Hexavalent chromium free. Using trivalent chromium for RoHS compliance.
- Two wheel types:
  - Phenolic
  - Reinforced Nylon with ball bearing spindle
- Wheel brake available on special order.

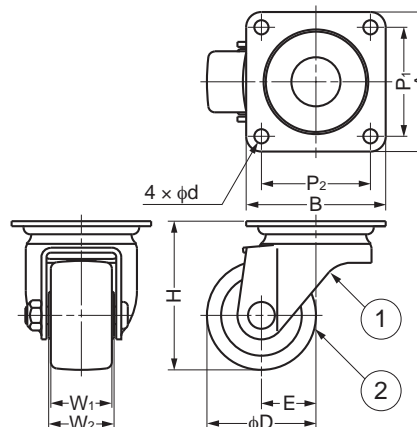

No.	Part Name	Material	Finish/Color
①	Body	Steel	Clear Zinc Chromate
②	Wheel	GNB/Reinforced Nylon	Black
		PB/Phenolic Resin	Black

Item Code	Item Name	Wheel Material	D	H	E	W <sub>1</sub>	W <sub>2</sub>	A	B	P <sub>1</sub>	P <sub>2</sub>	d	Swivel Radius	Load Capacity(pc)	Weight	Box	
200-130-399	HG-50GNB	Reinforced Nylon	50	68	25	28	30	64	64	50	50	6.5	51	1600N	163.2kgf	320g	36pcs
200-130-400	HG-65PB	Phenolic Resin	65	92	22	38	42	90	90	71	71	10.5	57	3000N	306 kgf	880g	20pcs
200-130-401	HG-75PB	Phenolic Resin	75	106	22	38	42	90	90	71	71	10.5	61	3200N	326 kgf	970g	20pcs

# LOW PROFILE HEAVY DUTY CASTER

LOAD CAPACITY  
163-306 kgf

HR



- Low profile and heavy duty up to 255kg, ideal for manufacturing equipment.
- Hardened frame for maximum rigidity and strength.
- Hexavalent chromium free. Using trivalent chromium for RoHS compliance.
- Two wheel types:
  - Phenolic
  - Reinforced Nylon with ball bearing spindle

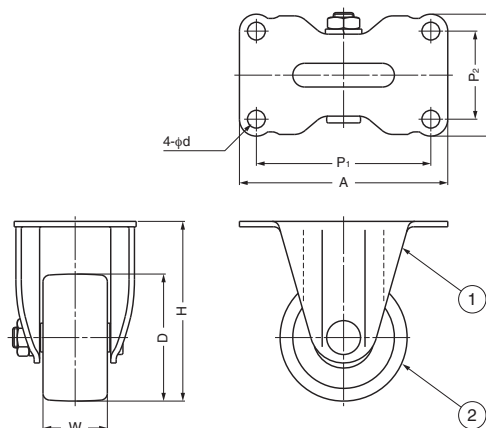

No.	Part Name	Material	Finish/Color
①	Body	Steel	Clear Zinc Chromate
②	Wheel	GNB/Reinforced Nylon	Black
		PB/Phenolic Resin	Black

Item Code	Item Name	Wheel Material	D	H	W	A	B	P <sub>1</sub>	P <sub>2</sub>	d	Load Capacity(pc)	Box	
200-130-843	HR-50-GNB	Reinforced Nylon	50	68	28	80	50	66	36	6.5	1600N	163.2kgf	36pcs
200-130-844	HR-65-PB	Phenolic Resin	65	92	38	111	67	91	47	10.5	2500N	255kgf	12pcs
200-130-845	HR-75-PB	Phenolic Resin	75	106	38	123	72	103	52	10.5	3000N	306kgf	12pcs

# LOW PROFILE HEAVY DUTY CASTER

LOAD CAPACITY  
204 kgf

HT-65PB



- Low profile and heavy duty up to 204kg, ideal for manufacturing equipment.
- Hardened frame provides maximum rigidity and strength.

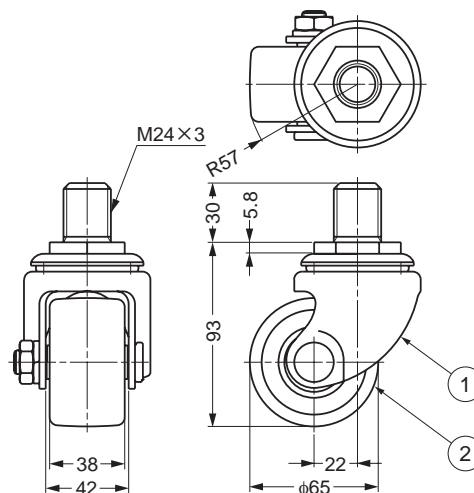

No.	Part Name	Material	Finish/Color
①	Body	Steel	Clear Zinc Chromate
②	Wheel	PB/Phenolic Resin	Black

Item Code	Item Name	Wheel Material	Load Capacity(pc)	Weight	Box	
200-130-398	HT-65PB	Phenolic Resin	2000N	204kgf	775g	20pcs

# HEAVY DUTY CASTER (PLATE TYPE)

LOAD CAPACITY  
120-300 kgf

TSG

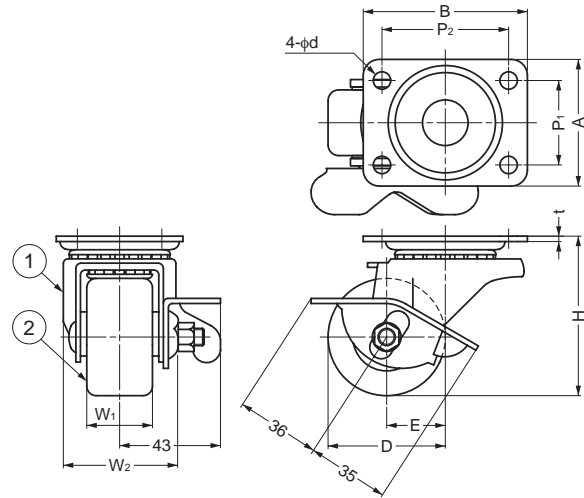

No.	Part Name	Material	Finish
①	Body	Steel	Clear Zinc Chromate
②	Wheel	Reinforced Nylon	Black

Item Code	Item Name	Spec.	D	W <sub>1</sub>	W <sub>2</sub>	E	H	A	B	P <sub>1</sub>	P <sub>2</sub>	t	d	Load Capacity(pc)	Weight	Carton	
200-133-131	TSGS-200-50	With Brake	50	28	48	25	68	54	70	36	54	3.2	6.5	1176N	120kgf	380g	50pcs
200-133-121	TSG-200-50	Without Brake	50	28	48	25	68	54	70	36	54	3.2	6.5	1176N	120kgf	380g	50pcs
200-133-122	TSG-250-65	Without Brake	65	38	63	30	92	90	90	71	71	4	10.5	2548N	260kgf	1100g	25pcs
200-133-123	TSG-300-75	Without Brake	75	38	63	30	106	90	90	71	71	4	10.5	2940N	300kgf	1200g	20pcs

# HEAVY DUTY CASTER (PLATE TYPE)

LOAD CAPACITY  
120-300 kgf

TSR

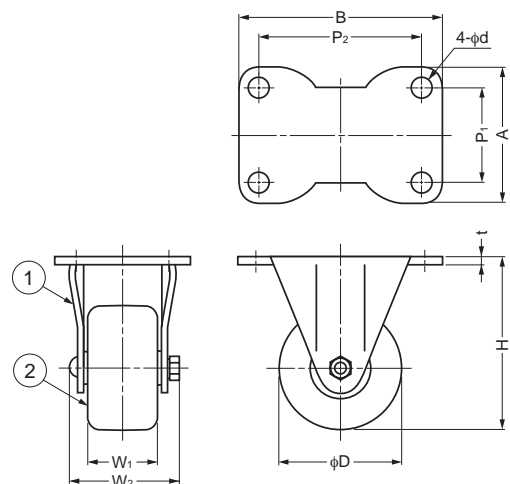

No.	Part Name	Material	Finish
①	Body	Steel	Clear Zinc Chromate
②	Wheel	Reinforced Nylon	Black

Item Code	Item Name	D	W <sub>1</sub>	W <sub>2</sub>	H	A	B	P <sub>1</sub>	P <sub>2</sub>	t	d	Load Capacity(pc)	Weight	Carton	
200-133-124	TSR-200-50	50	28	48	68	50	80	36	66	2.3	6.5	1176N	120kgf	250g	50pcs
200-133-125	TSR-250-65	65	38	63	92	67	111	47	91	3.2	10.5	2548N	260kgf	700g	25pcs
200-133-126	TSR-300-75	75	38	63	106	72	123	52	103	3.2	10.5	2940N	300kgf	850g	20pcs

STAINLESS STEEL CASTER (PLATE TYPE)



SUS-SJ



- Stainless steel (SUS304) product of superior waterproof and corrosion proof. Suitable for use in humid places and applications related to physical and chemical science, medical, and heating. When ordering, specify the wheel type and brake type.

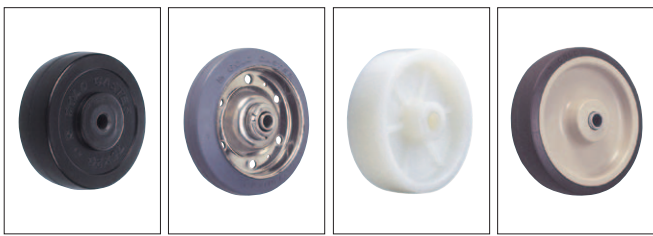

Rubber Rubber (w/B) Polyamide Urethane (w/B)

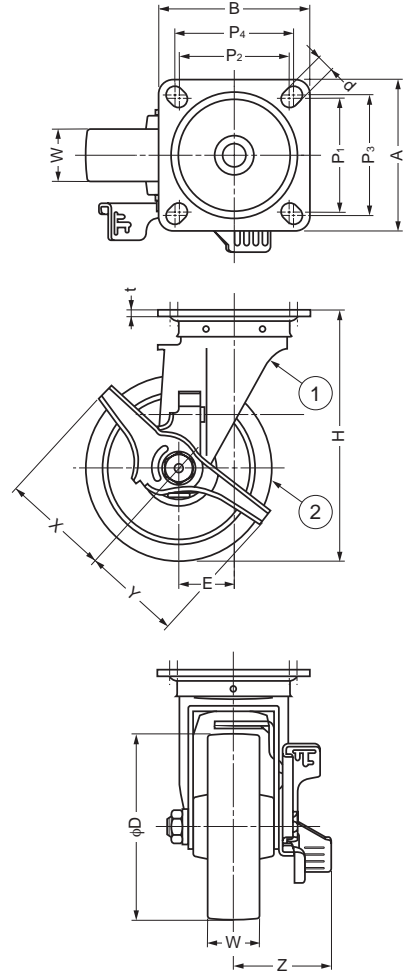

No.	Part Name	Material	Finish
①	Body	Stainless Steel (SUS304)	Satin
②	Wheel	R/Rubber	Black, Grey
		N/Polyamide	White
		UWB/Urethane	Ivory/Dark Brown

w/B: with bearing

Item Code	Item Name	Spec.	Wheel	Wheel Color	D	W	H	E	A	B	P <sub>1</sub>	P <sub>2</sub>	P <sub>3</sub>	P <sub>4</sub>	d	t	X	Y	Z	Load Capacity(pc)	Weight	Cartomn	
200-134-216	SUS-SJ65-S-R	With Brake	Rubber	Black	Without Wheel base	65	25	85	29	70	58	55	42	—	8.8	2	38	37	45	490N	50kgf	380g	40pcs
200-134-218	SUS-SJ65-S-N	With Brake	Polyamide	White	Without Wheel base	65	25	85	29	70	58	55	42	—	8.8	2	38	37	45	686N	70kgf	320g	40pcs
200-134-220	SUS-SJ65-S-UWB	With Brake	Urethane (w/B)	Ivory/Dark Brown	Without Wheel base	65	25	85	29	70	58	55	42	—	8.8	2	38	37	45	686N	70kgf	340g	40pcs
200-134-215	SUS-SJ65-R	Without Brake	Rubber	Black	Without Wheel base	65	25	85	29	70	58	55	42	—	8.8	2	—	—	—	490N	50kgf	340g	50pcs
200-134-217	SUS-SJ65-N	Without Brake	Polyamide	White	Without Wheel base	65	25	85	29	70	58	55	42	—	8.8	2	—	—	—	686N	70kgf	280g	50pcs
200-134-219	SUS-SJ65-UWB	Without Brake	Urethane (w/B)	Ivory/Dark Brown	Without Wheel base	65	25	85	29	70	58	55	42	—	8.8	2	—	—	—	686N	70kgf	300g	50pcs
200-134-222	SUS-SJ75-S-R	With Brake	Rubber	Black	Without Wheel base	75	25	93	28	70	58	55	42	—	8.8	2	38	37	45	588N	60kgf	420g	40pcs
200-134-224	SUS-SJ75-S-N	With Brake	Polyamide	White	Without Wheel base	75	25	93	28	70	58	55	42	—	8.8	2	38	37	45	784N	80kgf	360g	40pcs
200-134-226	SUS-SJ75-S-UWB	With Brake	Urethane (w/B)	Ivory/Dark Brown	Without Wheel base	75	25	93	28	70	58	55	42	—	8.8	2	38	37	45	784N	80kgf	380g	40pcs
200-134-221	SUS-SJ75-R	Without Brake	Rubber	Black	Without Wheel base	75	25	93	28	70	58	55	42	—	8.8	2	—	—	—	588N	60kgf	370g	50pcs
200-134-223	SUS-SJ75-N	Without Brake	Polyamide	White	Without Wheel base	75	25	93	28	70	58	55	42	—	8.8	2	—	—	—	784N	80kgf	310g	50pcs
200-134-225	SUS-SJ75-UWB	Without Brake	Urethane (w/B)	Ivory/Dark Brown	Without Wheel base	75	25	93	28	70	58	55	42	—	8.8	2	—	—	—	784N	80kgf	320g	50pcs
200-134-228	SUS-SJ100-S-R	With Brake	Rubber	Grey	With Wheel base	100	32	132	35	90	90	68	68	71	11	3	55	53	60	1176N	120kgf	1160g	15pcs
200-134-230	SUS-SJ100-S-RB	With Brake	Rubber (w/B)	Grey	With Wheel base	100	32	132	35	90	90	68	68	71	11	3	55	53	60	1176N	120kgf	1200g	15pcs
200-134-232	SUS-SJ100-S-N	With Brake	Polyamide	White	With Wheel base	100	32	132	35	90	90	68	68	71	11	3	55	53	60	1176N	120kgf	950g	15pcs
200-134-234	SUS-SJ100-S-NWB	With Brake	Polyamide (w/B)	White	With Wheel base	100	32	132	35	90	90	68	68	71	11	3	55	53	60	1176N	120kgf	1030g	15pcs
200-134-236	SUS-SJ100-S-UWB	With Brake	Urethane (w/B)	Ivory/Dark Brown	With Wheel base	100	32	132	35	90	90	68	68	71	11	3	55	53	60	1176N	120kgf	1070g	15pcs
200-134-227	SUS-SJ100-R	Without Brake	Rubber	Grey	With Wheel base	100	32	132	35	90	90	68	68	71	11	3	—	—	—	1176N	120kgf	1030g	15pcs
200-134-229	SUS-SJ100-RB	Without Brake	Rubber (w/B)	Grey	With Wheel base	100	32	132	35	90	90	68	68	71	11	3	—	—	—	1176N	120kgf	1070g	15pcs
200-134-231	SUS-SJ100-N	Without Brake	Polyamide	White	With Wheel base	100	32	132	35	90	90	68	68	71	11	3	—	—	—	1176N	120kgf	820g	15pcs
200-134-233	SUS-SJ100-NWB	Without Brake	Polyamide (w/B)	White	With Wheel base	100	32	132	35	90	90	68	68	71	11	3	—	—	—	1176N	120kgf	900g	15pcs
200-134-235	SUS-SJ100-UWB	Without Brake	Urethane (w/B)	Ivory/Dark Brown	With Wheel base	100	32	132	35	90	90	68	68	71	11	3	—	—	—	1176N	120kgf	940g	15pcs
200-134-238	SUS-SJ125-S-R	With Brake	Rubber	Grey	With Wheel base	125	38	168	38	102	102	75	75	80	11	4	70	67	65	1470N	150kgf	1660g	6pcs
200-134-240	SUS-SJ125-S-RB	With Brake	Rubber (w/B)	Grey	With Wheel base	125	38	168	38	102	102	75	75	80	11	4	70	67	65	1470N	150kgf	1790g	6pcs
200-134-242	SUS-SJ125-S-NWB	With Brake	Polyamide (w/B)	White	With Wheel base	125	35	168	38	102	102	75	75	80	11	4	70	67	65	1470N	150kgf	1510g	6pcs
200-134-244	SUS-SJ125-S-UWB	With Brake	Urethane (w/B)	Ivory/Dark Brown	With Wheel base	125	35	168	38	102	102	75	75	80	11	4	70	67	65	1470N	150kgf	1590g	6pcs
200-134-237	SUS-SJ125-R	Without Brake	Rubber	Grey	With Wheel base	125	35	168	38	102	102	75	75	80	11	4	—	—	—	1470N	150kgf	1520g	10pcs
200-134-239	SUS-SJ125-S-R	Without Brake	Rubber (w/B)	Grey	With Wheel base	125	35	168	38	102	102	75	75	80	11	4	—	—	—	1470N	150kgf	1650g	10pcs
200-134-241	SUS-SJ125-NWB	Without Brake	Polyamide (w/B)	White	With Wheel base	125	35	168	38	102	102	75	75	80	11	4	—	—	—	1470N	150kgf	1370g	10pcs
200-134-243	SUS-SJ125-UWB	Without Brake	Urethane (w/B)	Ivory/Dark Brown	With Wheel base	125	35	168	38	102	102	75	75	80	11	4	—	—	—	1470N	150kgf	1450g	10pcs

# STAINLESS STEEL CASTER (PLATE TYPE)



# SUS-SK



• Form of mounting hole depends on the size of product.

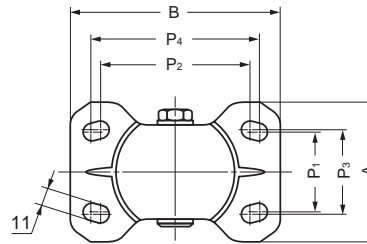

Wheel dia : 100 · 125 · 150mm

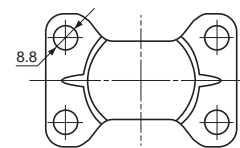
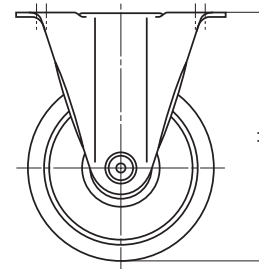
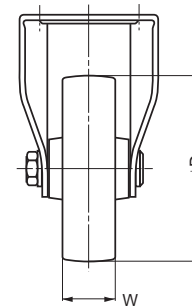

Wheel dia : 65 · 75mm

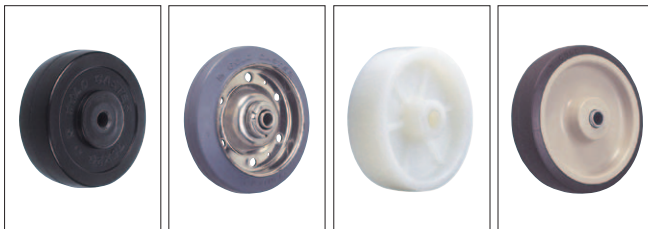

R/Rubber      Rubber (w/B)      N/Polyamide      UWB/Urethane (w/B)

No.	Part Name	Material	Finish
①	Body	Stainless Steel (SUS304)	Satin
②	Wheel	R/Rubber	Black, Grey
		N/Nylon	White
		UWB/Urethane	Ivory/Dark Brown

w/B: with bearing

Item Code	Item Name	Wheel	Wheel Color		D	W	H	A	B	P <sub>1</sub>	P <sub>2</sub>	P <sub>3</sub>	P <sub>4</sub>	Load Capacity(pc)	Weight	Carton	
200-134-253	SUS-SK65-R	Rubber	Black	Without Wheel base	65	25	85	47	70	28	55	—	—	490N	50kgf	220g	50pcs
200-134-255	SUS-SK65-N	Polyamide	White	Without Wheel base	65	25	85	47	70	28	55	—	—	686N	70kgf	160g	50pcs
200-134-257	SUS-SK65-UWB	Urethane (w/B)	Ivory/Dark Brown	Without Wheel base	65	25	85	47	70	28	55	—	—	686N	70kgf	180g	50pcs
200-134-259	SUS-SK75-R	Rubber	Black	Without Wheel base	75	25	93	47	70	28	55	—	—	588N	60kgf	260g	50pcs
200-134-261	SUS-SK75-N	Polyamide	White	Without Wheel base	75	25	93	47	70	28	55	—	—	784N	80kgf	200g	50pcs
200-134-263	SUS-SK75-UWB	Urethane (w/B)	Ivory/Dark Brown	Without Wheel base	75	25	93	47	70	28	55	—	—	784N	80kgf	220g	50pcs
200-134-265	SUS-SK100-R	Rubber	Grey	With Wheel base	100	32	132	78	110	45	80	50	90	1176N	120kgf	780g	15pcs
200-134-267	SUS-SK100-RB	Rubber (w/B)	Grey	With Wheel base	100	32	132	78	110	45	80	50	90	1176N	120kgf	820g	15pcs
200-134-269	SUS-SK100-N	Polyamide	White	With Wheel base	100	32	132	78	110	45	80	50	90	1176N	120kgf	570g	15pcs
200-134-271	SUS-SK100-NWB	Polyamide (w/B)	White	With Wheel base	100	32	132	78	110	45	80	50	90	1176N	120kgf	650g	15pcs
200-134-273	SUS-SK100-UWB	Urethane (w/B)	Ivory/Dark Brown	With Wheel base	100	32	132	78	110	45	80	50	90	1176N	120kgf	690g	15pcs
200-134-275	SUS-SK125-R	Rubber	Grey	With Wheel base	125	38	168	94	140	56	100	53	112	1470N	150kgf	1210g	10pcs
200-134-277	SUS-SK125-RB	Rubber (w/B)	Grey	With Wheel base	125	38	168	94	140	56	100	53	112	1470N	150kgf	1340g	10pcs
200-134-279	SUS-SK125-NWB	Polyamide (w/B)	White	With Wheel base	125	35	168	94	140	56	100	53	112	1470N	150kgf	1060g	10pcs
200-134-281	SUS-SK125-UWB	Urethane (w/B)	Ivory/Dark Brown	With Wheel base	125	38	168	94	140	56	100	53	112	1568N	160kgf	1140g	10pcs
200-134-283	SUS-SK150-R	Rubber	Grey	With Wheel base	150	40	190	94	140	56	100	53	112	1568N	160kgf	1480g	8pcs
200-134-285	SUS-SK150-RB	Rubber (w/B)	Grey	With Wheel base	150	40	190	94	140	56	100	53	112	1568N	160kgf	1600g	8pcs
200-134-287	SUS-SK150-NWB	Polyamide (w/B)	White	With Wheel base	150	35	190	94	140	56	100	53	112	1568N	160kgf	1160g	8pcs
200-134-289	SUS-SK150-UWB	Urethane (w/B)	Ivory/Dark Brown	With Wheel base	150	38	190	94	140	56	100	53	112	1568N	160kgf	1350g	8pcs

# STAINLESS STEEL CASTER (PLATE TYPE)

LOAD CAPACITY  
30-61 kgf

STAINLESS  
304  
STEEL

## SUS-E



- Stainless steel (SUS304) product of superior waterproof and corrosion proof.
- Suitable for use in humid places and applications related to physical and chemical science, medical and commercial kitchen.

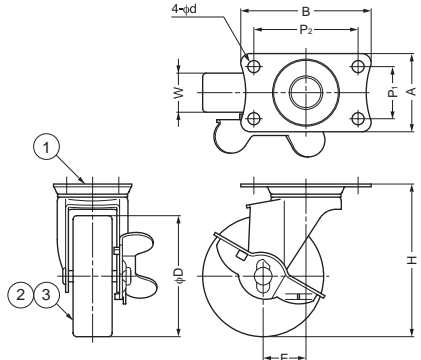

No.	Part Name	Material	Finish/Color
①	Body	Stainless Steel(SUS304)	Polished
②	Wheel	N/Polyamide	White
		UR/Urethane	Brown+White
		RH/Hard Rubber	Black
③	Wheel base	Polyamide	White

Item Code	Item Name	Spec.	Wheel	D	H	E	W	A	B	P <sub>1</sub>	P <sub>2</sub>	d	Load Capacity	Weight	Box	
200-012-556	SUS-E-50NS	With Brake	Polyamide	50	65	22	21	42	70	28	56	6.5	400N	40.8kgf	165g	80pcs
200-012-557	SUS-E-50URS	With Brake	Urethane	50	65	22	21	42	70	28	56	6.5	380N	38.8kgf	175g	80pcs
200-012-558	SUS-E-50N	Without Brake	Polyamide	50	65	22	21	42	70	28	56	6.5	400N	40.8kgf	150g	100pcs
200-012-559	SUS-E-50UR	Without Brake	Urethane	50	65	22	21	42	70	28	56	6.5	380N	38.8kgf	160g	100pcs
200-012-562	SUS-E-65RHS	With Brake	Hard Rubber	65	82	23	21	42	70	28	56	6.5	300N	30.6kgf	255g	60pcs
200-012-560	SUS-E-65NS	With Brake	Polyamide	65	82	23	21	42	70	28	56	6.5	400N	40.8kgf	185g	60pcs
200-012-561	SUS-E-65URS	With Brake	Urethane	65	82	23	21	42	70	28	56	6.5	400N	40.8kgf	200g	60pcs
200-012-565	SUS-E-65RH	Without Brake	Hard Rubber	65	82	23	21	42	70	28	56	6.5	300N	30.6kgf	235g	70pcs
200-012-563	SUS-E-65N	Without Brake	Polyamide	65	82	23	21	42	70	28	56	6.5	400N	40.8kgf	170g	70pcs
200-012-564	SUS-E-65UR	Without Brake	Urethane	65	82	23	21	42	70	28	56	6.5	400N	40.8kgf	185g	70pcs
200-012-568	SUS-E-75RHS	With Brake	Hard Rubber	75	92	27	21	42	70	28	56	6.5	400N	40.8kgf	265g	50pcs
200-012-566	SUS-E-75NS	With Brake	Polyamide	75	92	27	21	42	70	28	56	6.5	500N	51.0kgf	195g	50pcs
200-012-567	SUS-E-75URS	With Brake	Urethane	75	92	27	21	42	70	28	56	6.5	450N	45.9kgf	210g	50pcs
200-012-571	SUS-E-75RH	Without Brake	Hard Rubber	75	92	27	21	42	70	28	56	6.5	400N	40.8kgf	265g	60pcs
200-012-569	SUS-E-75N	Without Brake	Polyamide	75	92	27	21	42	70	28	56	6.5	500N	51.0kgf	180g	60pcs
200-012-570	SUS-E-75UR	Without Brake	Urethane	75	92	27	21	42	70	28	56	6.5	450N	45.9kgf	195g	60pcs
200-012-574	SUS-E-100RHS	With Brake	Hard Rubber	100	122	31	25	58	100	40	82	8.8	500N	51.0kgf	555g	30pcs
200-012-572	SUS-E-100NS	With Brake	Polyamide	100	122	31	25	58	100	40	82	8.8	600N	61.2kgf	360g	30pcs
200-012-573	SUS-E-100URS	With Brake	Urethane	100	122	31	28	58	100	40	82	8.8	600N	61.2kgf	405g	30pcs
200-012-577	SUS-E-100RH	Without Brake	Hard Rubber	100	122	31	25	58	100	40	82	8.8	500N	51.0kgf	490g	35pcs
200-012-575	SUS-E-100N	Without Brake	Polyamide	100	122	31	25	58	100	40	82	8.8	600N	61.2kgf	310g	35pcs
200-012-576	SUS-E-100UR	Without Brake	Urethane	100	122	31	28	58	100	40	82	8.8	600N	61.2kgf	340g	35pcs

# STAINLESS STEEL CASTER (PLATE TYPE)

LOAD CAPACITY  
30-61 kgf

STAINLESS  
304  
STEEL

## SUS-ER



- Stainless steel (SUS304) product of superior waterproof and corrosion proof.
- Suitable for use in humid places and applications related to physical and chemical science, medical and commercial kitchen.

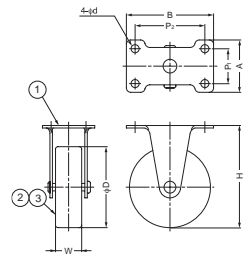

No.	Part Name	Material	Finish/Color
①	Body	Stainless Steel(SUS304)	Polished
②	Wheel	RH/Hard Rubber	Black
		N/Polyamide	White
		UR/Urethane	Brown+White
③	Wheel base	Polyamide	White

Item Code	Item Name	Wheel	D	W	H	A	B	P <sub>1</sub>	P <sub>2</sub>	d	Load Capacity	Weight	Box	
200-014-090	SUS-ER-50N	Polyamide	50	21	65	42	70	28	56	6.5	400N	40.8kgf	100g	100pcs
200-014-091	SUS-ER-50UR	Urethane	50	21	65	42	70	28	56	6.5	380N	38.8kgf	110g	100pcs
200-014-092	SUS-ER-65RH	Hard Rubber	65	21	82	42	70	28	56	6.5	300N	30.6kgf	185g	70pcs
200-014-093	SUS-ER-65N	Polyamide	65	21	82	42	70	28	56	6.5	400N	40.8kgf	125g	70pcs
200-014-094	SUS-ER-65UR	Urethane	65	21	82	42	70	28	56	6.5	400N	40.8kgf	135g	70pcs
200-014-095	SUS-ER-75RH	Hard Rubber	75	21	92	42	70	28	56	6.5	400N	40.8kgf	220g	60pcs
200-014-096	SUS-ER-75N	Polyamide	75	21	92	42	70	28	56	6.5	500N	51.0kgf	135g	60pcs
200-014-097	SUS-ER-75UR	Urethane	75	21	92	42	70	28	56	6.5	450N	45.9kgf	150g	60pcs
200-014-098	SUS-ER-100RH	Hard Rubber	100	25	122	58	100	40	82	8.8	500N	51.0kgf	485g	24pcs
200-014-099	SUS-ER-100N	Polyamide	100	25	122	58	100	40	82	8.8	600N	61.2kgf	305g	24pcs
200-014-110	SUS-ER-100UR	Urethane	100	28	122	58	100	40	82	8.8	600N	61.2kgf	340g	24pcs



# STAINLESS STEEL CASTER (THREADED BOLT TYPE)

LOAD CAPACITY  
30-61 kgf

STAINLESS  
304  
STEEL

## SUS-ET



- Stainless steel (SUS304) product of superior waterproof and corrosion proof.
- Suitable for use in humid places and applications related to physical and chemical science, medical and commercial kitchen.



Polyamide Urethane Hard rubber

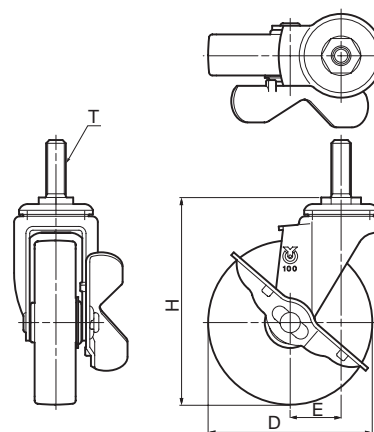

The drawing above show the model with Brake

### Parts set for installation on aluminium profile (Option)

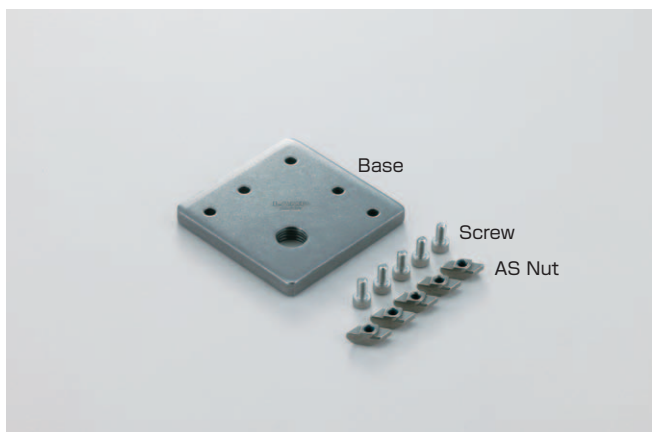

No.	Part Name	Material	Finish/Color
①	Body	Stainless Steel(SUS304)	Polished
②	Wheel	R/Rubber	Black
		N/Polyamide	White
		NR/Polyamide Rubber	Black,Grey
		UR/Urethane	Brown/White
		RH/Hard Rubber	Black
③	Wheel base	Polyamide	White

Item Code	Item Name	Spec.	Wheel Material	D	H	E	T	Load Capacity(pc)	Weight	Carton	
200-130-878	SUS-ET-50RS	With Brake	Rubber	50	68	22	M12	300N	30.6kgf	210g	80pcs
200-130-879	SUS-ET-50NS	With Brake	Polyamide	50	68	22	M12	400N	40.8kgf	180g	80pcs
200-130-880	SUS-ET-50URS	With Brake	Urethane	50	68	22	M12	380N	38.8kgf	190g	80pcs
200-130-865	SUS-ET-50R	Without Brake	Rubber	50	68	22	M12	300N	30.6kgf	195g	100pcs
200-130-866	SUS-ET-50N	Without Brake	Polyamide	50	68	22	M12	400N	40.8kgf	165g	100pcs
200-130-867	SUS-ET-50UR	Without Brake	Urethane	50	68	22	M12	380N	38.8kgf	175g	100pcs
200-130-881	SUS-ET-65RHS	With Brake	Hard Rubber	65	85	23	M12	300N	30.6kgf	225g	60pcs
200-130-882	SUS-ET-65NS	With Brake	Polyamide	65	85	23	M12	400N	40.8kgf	200g	60pcs
200-130-883	SUS-ET-65URS	With Brake	Urethane	65	85	23	M12	400N	40.8kgf	220g	60pcs
200-130-868	SUS-ET-65RH	Without Brake	Hard Rubber	65	85	23	M12	300N	30.6kgf	245g	70pcs
200-130-869	SUS-ET-65N	Without Brake	Polyamide	65	85	23	M12	400N	40.8kgf	185g	70pcs
200-130-870	SUS-ET-65UR	Without Brake	Urethane	65	85	23	M12	400N	40.8kgf	195g	70pcs
200-130-884	SUS-ET-75RHS	With Brake	Hard Rubber	75	95	27	M12	400N	40.8kgf	295g	50pcs
200-130-885	SUS-ET-75NS	With Brake	Polyamide	75	95	27	M12	500N	51.0kgf	210g	50pcs
200-130-886	SUS-ET-75URS	With Brake	Urethane	75	95	27	M12	450N	45.9kgf	230g	50pcs
200-130-871	SUS-ET-75RH	Without Brake	Hard Rubber	75	95	27	M12	400N	40.8kgf	250g	60pcs
200-130-872	SUS-ET-75N	Without Brake	Polyamide	75	95	27	M12	500N	51.0kgf	195g	60pcs
200-130-873	SUS-ET-75UR	Without Brake	Urethane	75	95	27	M12	450N	45.9kgf	210g	60pcs
200-130-887	SUS-ET-100RHS	Without Brake	Hard Rubber	100	126	31	M12	500N	51.0kgf	615g	35pcs
200-130-888	SUS-ET-100NRS	With Brake	Polyamide Rubber	100	126	31	M12	600N	61.2kgf	550g	35pcs
200-130-889	SUS-ET-100NS	With Brake	Polyamide	100	126	31	M12	600N	61.2kgf	420g	35pcs
200-130-890	SUS-ET-100URS	With Brake	Urethane	100	126	31	M12	600N	61.2kgf	470g	35pcs
200-130-874	SUS-ET-100RH	Without Brake	Hard Rubber	100	126	31	M12	500N	51.0kgf	555g	24pcs
200-130-875	SUS-ET-100NR	Without Brake	Polyamide Rubber	100	126	31	M12	600N	61.2kgf	490g	40pcs
200-130-876	SUS-ET-100N	Without Brake	Polyamide	100	126	31	M12	600N	61.2kgf	375g	24pcs
200-130-877	SUS-ET-100UR	Without Brake	Urethane	100	126	31	M12	600N	61.2kgf	405g	40pcs

# WHEEL CASTER (PLATE TYPE)

LOAD CAPACITY  
20-60 kgf

# TSG, TSGS

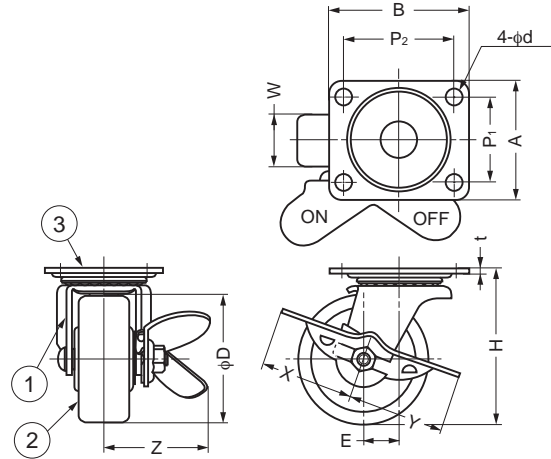
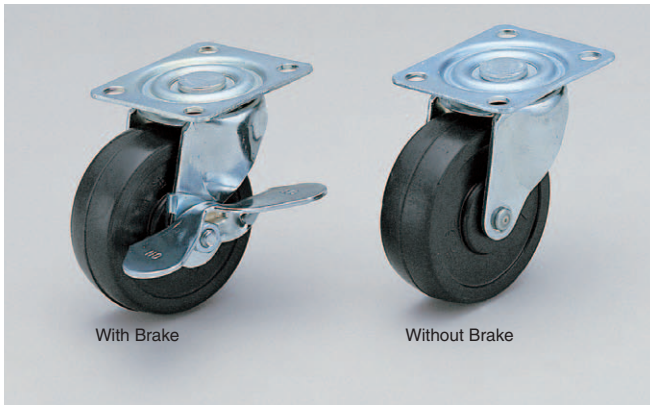

No.	Part Name	Material	Finish/Color
①	Body	Steel	See①Body Finish
②	Wheel	Styrene-butadiene rubber	Black
③	Plate	Steel	Clear Zinc Chromate

Item Code	Item Name	Spec.	D	W	H	E	A	B	P <sub>1</sub>	P <sub>2</sub>	d	t	X	Y	Z	Load Capacity(pc)	Weight	Brake Shapes	Box	Carton	
200-133-052	TSGS211-40	With Brake	40	18	55	18	37	54	27	42	5.2	2	26.5	27.5	30	196N	20kgf	155g	1	8pcs	136pcs
200-133-051	TSG211-40	Without Brake	40	18	55	18	37	54	27	42	5.2	2	-	-	-	196N	20kgf	137g	-	8pcs	200pcs
200-133-054	TSGS212-50	With Brake	50	20	65	20	46	60	35	46	6.2	2	35.5	41.5	30	294N	30kgf	192g	1	8pcs	112pcs
200-133-053	TSG212-50	Without Brake	50	20	65	20	46	60	35	46	6.2	2	-	-	-	294N	30kgf	174g	-	8pcs	136pcs
200-133-056	TSGS220-55	With Brake	55	25	73	18	60	70	42	55	8.5	2.3	38.5	38.5	43	392N	40kgf	380g	2	4pcs	32pcs
200-133-055	TSG220-55	Without Brake	55	25	73	18	60	70	42	55	8.5	2.3	-	-	-	392N	40kgf	330g	-	4pcs	64pcs
200-133-058	TSGS221-65	With Brake	65	25	78	18	60	70	42	55	8.5	2.3	41.5	42	50	441N	45kgf	400g	2	4pcs	32pcs
200-133-057	TSG221-65	Without Brake	65	25	78	18	60	70	42	55	8.5	2.3	-	-	-	441N	45kgf	350g	-	4pcs	64pcs
200-133-060	TSGS222-75	With Brake	75	25	90	24	60	70	42	55	8.5	2.3	41.5	42	50	490N	50kgf	480g	2	4pcs	32pcs
200-133-059	TSG222-75	Without Brake	75	25	90	24	60	70	42	55	8.5	2.3	-	-	-	490N	50kgf	430g	-	4pcs	48pcs
200-133-062	TSGS143-100	With Brake	100	26	119	30	60	70	44	54	9.2	2.3	70	-	-	588N	60kgf	740g	3	-	30pcs
200-133-061	TSG143-100	Without Brake	100	26	119	30	60	70	44	54	9.2	2.3	-	-	-	588N	60kgf	700g	-	-	40pcs

# WHEEL CASTER (PLATE TYPE)

LOAD CAPACITY  
20-60 kgf

# TSR

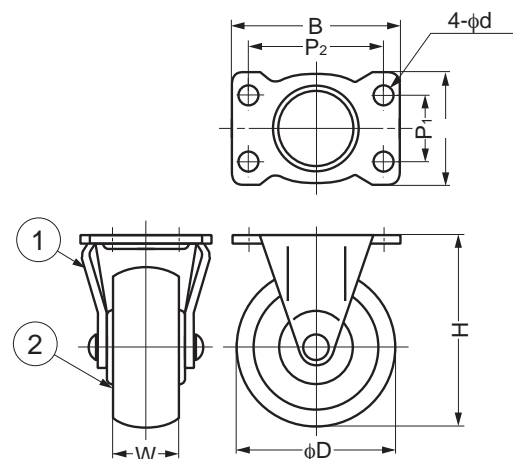

No.	Part Name	Material	Finish/Color
①	Body	Steel	See①Body Finish
②	Wheel	Styrene-butadiene rubber	Black

Item Code	Item Name	D	W	H	A	B	P <sub>1</sub>	P <sub>2</sub>	d	① Body Finish	Load Capacity(pc)	Weight	Box	Carton	
200-133-063	TSR249-40	40	18	55	37	54	27	42	5.2	Clear Zinc Chromate	196N	20kgf	70g	8pcs	200pcs
200-133-064	TSR250-50	50	20	65	40	58	25	45	6.2	Clear Zinc Chromate	294N	30kgf	140g	8pcs	136pcs
200-133-065	TSR251-55	55	25	73	47	70	28	55	8.5	Chrome	392N	40kgf	195g	4pcs	64pcs
200-133-066	TSR252-65	65	25	78	47	70	28	55	8.5	Chrome	441N	45kgf	280g	4pcs	64pcs
200-133-067	TSR253-75	75	25	90	44	69	28	55	8.5	Chrome	490N	50kgf	300g	4pcs	48pcs
200-133-068	TSR254-100	100	26	120	60	70	30	43	9.2	Chrome	588N	60kgf	600g	-	30pcs

## TWIN WHEEL CASTER (PLATE TYPE)

TEST

LOAD CAPACITY  
200 kgf

### GX75PS, P

• Heavy duty and low profile.

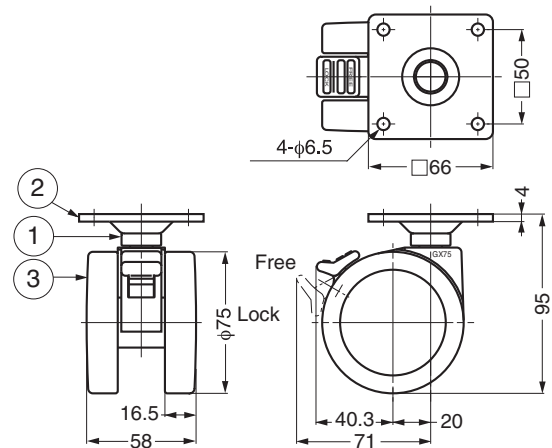
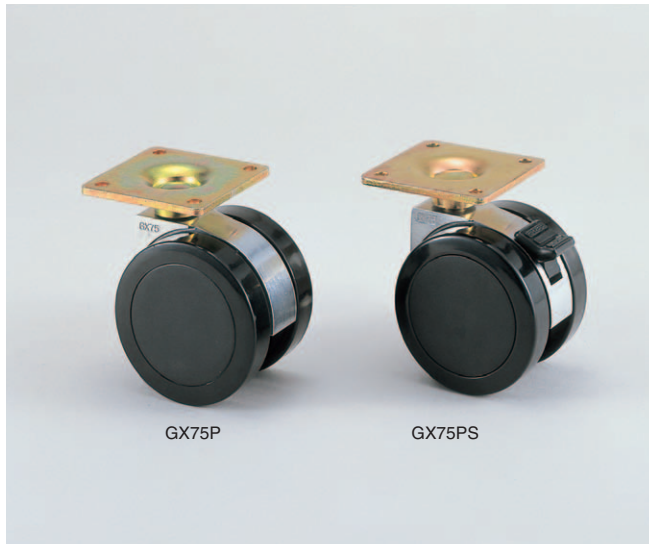

The drawing above show the model with Brake

No.	Part Name	Material	Finish/Color
①	Body	Aluminum Alloy	Polished
②	Plate	Steel	Yellow Zinc Chromate
③	Wheel	Polyamide	Black

Item Code	Item Name	Spec.	Load Capacity(pc)		Weight	Box	Carton
200-133-218	GX75PS	With Brake	1960N	200kgf	445g	2pcs	24pcs
200-133-217	GX75P	Without Brake	1960N	200kgf	430g	2pcs	24pcs

## TWIN WHEEL CASTER (THREADED BOLT TYPE)

TEST

LOAD CAPACITY  
200 kgf

### GX75N16S, N16

• Heavy duty and low profile.

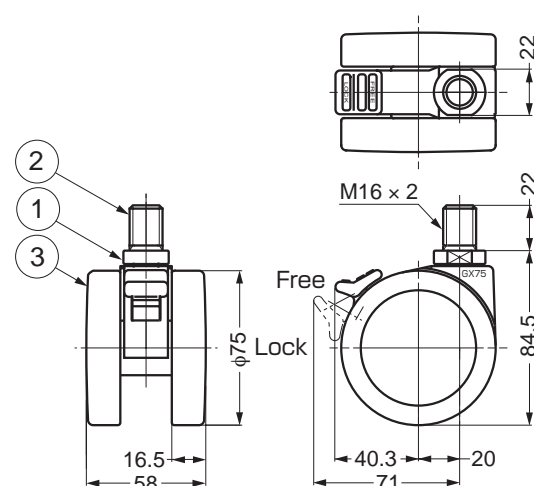

The drawing above show the model with Brake

No.	Part Name	Material	Finish/Color
①	Body	Aluminum Alloy	Polished
②	Threaded Bolt	Steel	Yellow Zinc Chromate
③	Wheel	Polyamide	Black

Item Code	Item Name	Spec.	Load Capacity(pc)		Weight	Box	Carton
200-133-220	GX75N16S	With Brake	1960N	200kgf	350g	2pcs	24pcs
200-133-219	GX75N16	Without Brake	1960N	200kgf	340g	2pcs	24pcs

## TWIN WHEEL CASTER (PLATE TYPE)

TEST

LOAD CAPACITY  
150 kgf

## GX60PS, P



• Heavy duty and low profile.

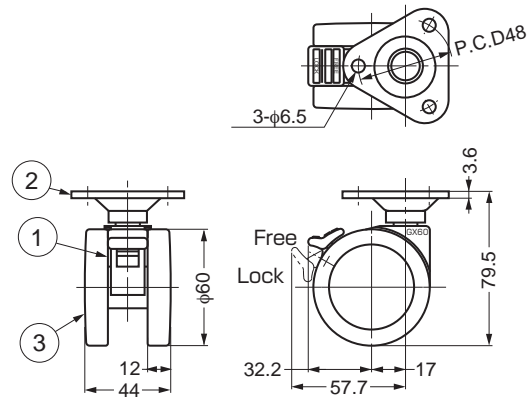

The drawing above show the model with Brake

No.	Part Name	Material	Finish/Color
①	Body	Aluminum Alloy	Polished
②	Plate	Steel	Yellow Zinc Chromate
③	Wheel	Polyamide	Black

Item Code	Item Name	Spec	Load Capacity(pc)		Weight	Box	Carton
200-133-181	GX60PS	With Brake	1470N	150kgf	225g	4pcs	60pcs
200-130-033	GX60P	Without Brake	1470N	150kgf	225g	4pcs	60pcs

## TWIN WHEEL CASTER (THREADED BOLT TYPE)

TEST

LOAD CAPACITY  
150 kgf

## GX60N12S, N12



• Heavy duty and low profile.

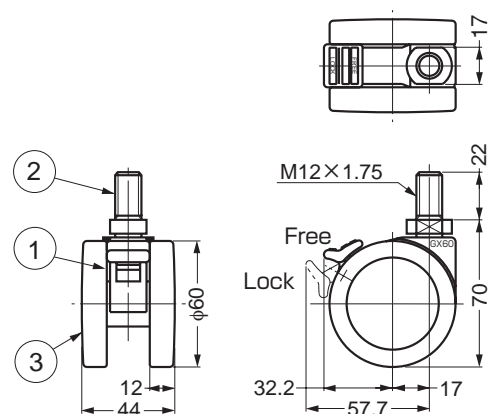

The drawing above show the model with Brake

No.	Part Name	Material	Finish/Color
①	Body	Aluminum Alloy	Polished
②	Threaded Bolt	Steel	Yellow Zinc Chromate
③	Wheel	Polyamide	Black

Item Code	Item Name	Spec	Load Capacity(pc)		Weight	Box	Carton
200-133-183	GX60N12S	With Brake	1470N	150kgf	185g	4pcs	60pcs
200-133-182	GX60N12	Without Brake	1470N	150kgf	180g	4pcs	60pcs

## TWIN WHEEL CASTER (PLATE TYPE)

TEST

LOAD CAPACITY  
100 kgf

### GX50PS, P

• Heavy duty and low profile.

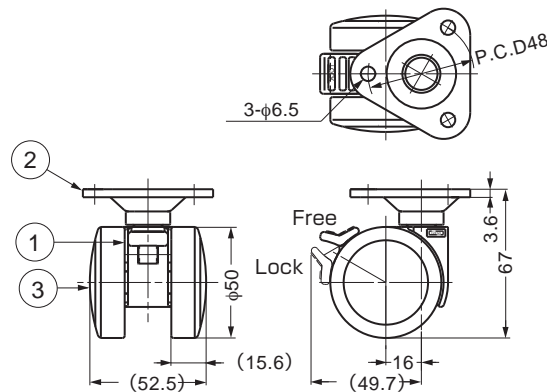

The drawing above show the model with Brake

No.	Part Name	Material	Finish/Color
①	Body	Aluminum Alloy	Polished
②	Plate	Steel	Yellow Zinc Chromate
③	Wheel	Polyamide	Black

Item Code	Item Name	Spec	Load Capacity		Weight	Box	Carton
200-133-173	GX50PS	With Brake	980N	100kgf	235g	4pcs	72pcs
200-133-172	GX50P	Without Brake	980N	100kgf	230g	4pcs	72pcs

## TWIN WHEEL CASTER (THREADED BOLT TYPE)

TEST

LOAD CAPACITY  
100 kgf

### GX50N12S, N12

• Heavy duty and low profile.

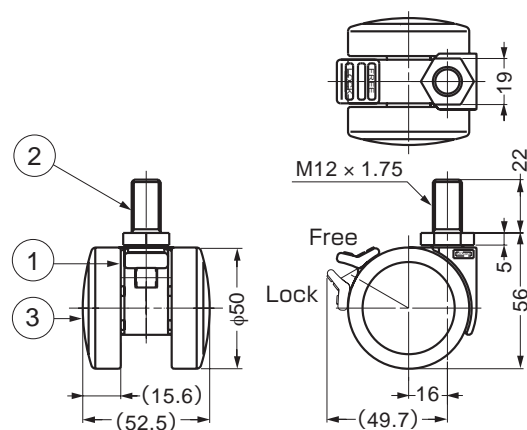

The drawing above show the model with Brake

No.	Part Name	Material	Finish/Color
①	Body	Aluminum Alloy	Polished
②	Threaded Bolt	Steel	Yellow Zinc Chromate
③	Wheel	Polyamide	Black

Item Code	Item Name	Spec	Load Capacity(pc)		Weight	Box	Carton
200-133-175	GX50N12S	With Brake	980N	100kgf	175g	4pcs	72pcs
200-133-174	GX50N12	Without Brake	980N	100kgf	170g	4pcs	72pcs

## TWIN WHEEL CASTER (THREADED BOLT & PLATE)

TEST

LOAD CAPACITY  
200 kgf

### GX-W50GP



- Heavy duty and low profile.
- Use in combination with GX-W50K (Non-swivel type) for easy handling.
- Threaded bolt or plate type available.

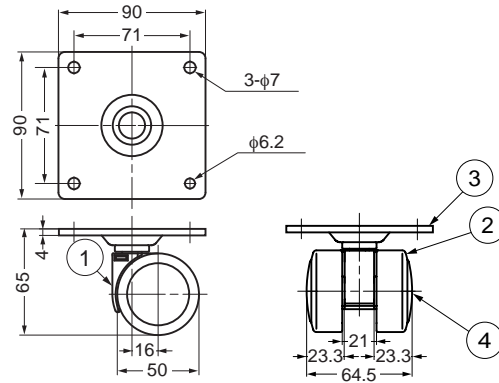

No.	Part Name	Material	Finish/Color
①	Body	Aluminum Alloy	Polished
②	Wheel	Polycetal	Black
③	Plate	Steel	Yellow Zinc Chromate
④	Cover	Polyamide	Black

Item Code	Item Name	Load Capacity(pc)		Weight	Box	Carton
200-130-027	GX-W50GP	1960N	200kgf	420g	2pcs	40pcs

## TWIN WHEEL CASTER (THREADED BOLT & PLATE)

TEST

LOAD CAPACITY  
200 kgf

### GX-W50GN



- Heavy duty and low profile.
- Use in combination with GX-W50K (Non-swivel type) for easy handling.
- Threaded bolt or plate type available.

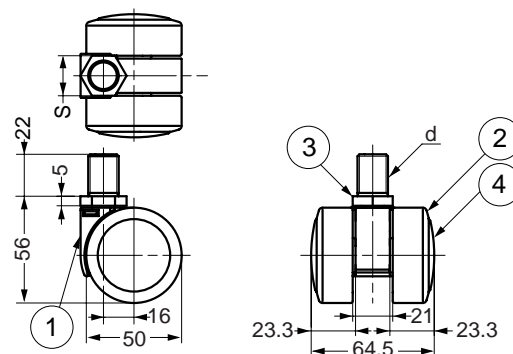

No.	Part Name	Material	Finish/Color
①	Body	Aluminum Alloy	Polished
②	Wheel	Polycetal	Black
③	Threaded Bolt Mounting Plate (GP)	Steel	Yellow Zinc Chromate
④	Cover	Polyamide	Black

Item Code	Item Name	d	S	Load Capacity(pc)		Weight	Box	Carton
200-130-028	GX-W50GN12	M12	19	1960N	200kgf	208g	4pcs	80pcs
200-130-029	GX-W50GN16	M16	21	1960N	200kgf	223g	4pcs	80pcs

# TWIN WHEEL CASTER (NON-SWIVEL)



# GX-W50K

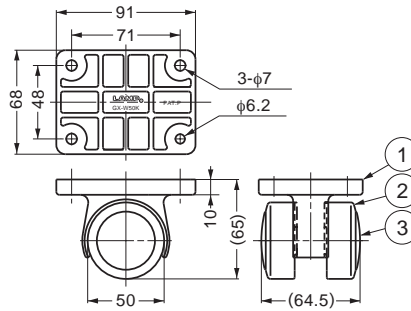

- Non-swivel (Rigid) caster.
- Heavy duty and low profile.
- Use in combination with GX-W50GN12, GN16 or GP (Swivel Type) for easy handling.

No.	Part Name	Material	Finish/Color
①	Body	Aluminum Alloy	Polished
②	Wheel	Polyacetal	Black
③	Cover	Polyamide	Black

Item Code	Item Name	Load Capacity(pc)		Weight	Box	Carton
200-130-032	GX-W50K	1960N	200kgf	300g	2pcs	48pcs

# CASTER (PLATE TYPE)



# T, TSD

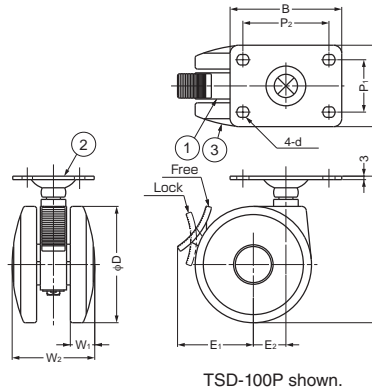

- Wheels absorb vibrations with urethane for smooth and quiet movement.

No.	Part Name	Material	Finish/Color
①	Body	Polyamide	Light Grey
②	Plate	Steel	Clear Zinc Chromate
③	Wheel	Polyamide+Urethane	Light Grey

Item Code	Item Name	Spec.	D	W <sub>1</sub>	W <sub>2</sub>	H	A	B	P <sub>1</sub>	P <sub>2</sub>	E <sub>1</sub>	E <sub>2</sub>	d	Load Capacity(pc)	Weight	Carton	
200-130-167	TSD-75P	With Brake	76	19	61	94	58	70	42	55	45	21	8.5	784N	80kgf	340g	60pcs
200-130-166	T-75P	Without Brake	76	19	61	94	58	70	42	55	45	21	8.5	784N	80kgf	320g	60pcs
200-130-431	TSD-100P	With Brake	100	20	69	126.5	70	96	45	74	64	28	9×10.5	980N	100kgf	710g	20pcs
200-130-432	T-100P	Without Brake	100	20	69	126.5	70	96	45	74	64	28	9×10.5	980N	100kgf	700g	20pcs

# CASTER (THREADED BOLT TYPE)



# T, TSD

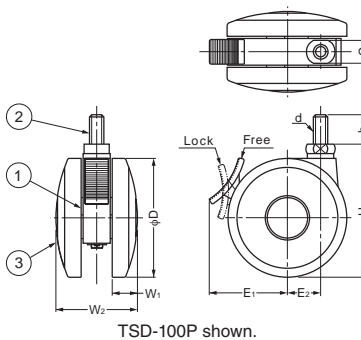

- Wheels absorb vibrations with urethane for smooth and quiet movement.

No.	Part Name	Material	Finish/Color
①	Body	Polyamide	Light Grey
②	Threaded Bolt	Steel	Clear Zinc Chromate
③	Wheel	Polyamide+Urethane	Light Grey

Item Code	Item Name	Spec.	D	W <sub>1</sub>	W <sub>2</sub>	H	h	E <sub>1</sub>	E <sub>2</sub>	C	d	Load Capacity(pc)	Weight	Carton	
200-130-169	TSD-75B	With Brake	76	19	61	86	20	45	21	17	M10×1.5	784N	80kgf	260g	60pcs
200-130-165	T-75B	Without Brake	76	19	61	86	20	45	21	17	M10×1.5	784N	80kgf	240g	60pcs
200-130-430	TSD-100B	With Brake	100	20	69	117.5	25	64	28	21	M12×1.25	980N	100kgf	565g	20pcs
200-130-168	T-100B	Without Brake	100	20	69	117.5	25	64	28	21	M12×1.25	980N	100kgf	555g	20pcs
200-133-159	TSD-100BM16	With Brake	100	20	69	117.5	25	64	28	21	M16×2	980N	100kgf	565g	20pcs
200-133-158	T-100BM16	Without Brake	100	20	69	117.5	25	64	28	21	M16×2	980N	100kgf	555g	20pcs

## TWIN WHEEL CASTER (PLATE TYPE)

LOAD CAPACITY  
70 kgf

## FAU55PS, P



- Wheels absorb vibrations with elastomer covering (rubber) for smooth and quiet movement.
- Light & durable aluminum body construction.



Use of FAU55-FIX (P.419) prevents caster swivel.

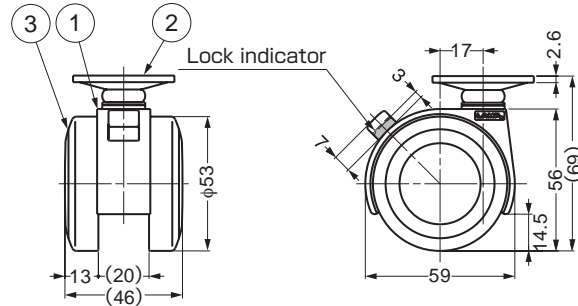
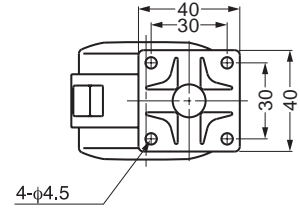
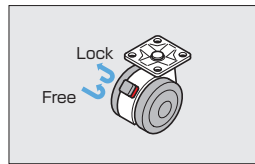

No.	Part Name	Material	Finish/Color
①	Body	Aluminum Alloy	Silver
②	Plate	Steel	Yellow Zinc Chromate
③	Wheel	Polyamide + Synthetic Rubber	Black

Item Code	Item Name	Spec	Load Capacity(pc)		Weight	Box	Carton
200-133-278	FAU55PSR	With Brake	686N	70kgf	179g	4pcs	72pcs
200-133-283	FAU55PR	Without Brake	686N	70kgf	175g	4pcs	72pcs

## TWIN WHEEL CASTER (THREADED BOLT TYPE)

LOAD CAPACITY  
70 kgf

## FAU55N



- Wheels absorb vibrations with elastomer covering (rubber) for smooth and quiet movement.
- Light & durable aluminum body construction.

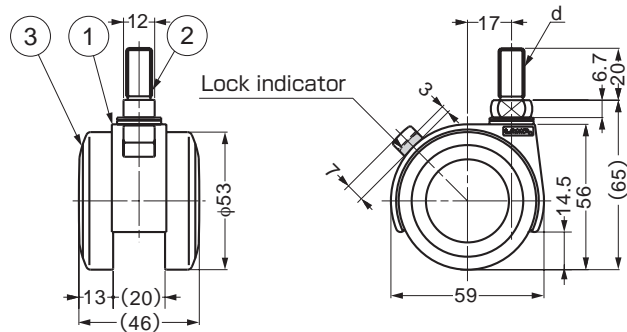
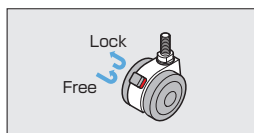

No.	Part Name	Material	Finish/Color
①	Body	Aluminum Alloy	Silver
②	Threaded Bolt	Steel	Yellow Zinc Chromate
③	Wheel	Polyamide + Synthetic Rubber	Black

Item Code	Item Name	Spec	d	Load Capacity(pc)		Weight	Box	Carton
200-133-279	FAU55N3SR	With Brake	W3/8	686N	70kgf	155g	4pcs	72pcs
200-133-284	FAU55N3R	Without Brake	W3/8	686N	70kgf	151g	4pcs	72pcs
200-133-280	FAU55N10SR	With Brake	M10	686N	70kgf	155g	4pcs	72pcs
200-133-285	FAU55N10R	Without Brake	M10	686N	70kgf	151g	4pcs	72pcs
200-133-281	FAU55N12SR	With Brake	M12	686N	70kgf	155g	4pcs	72pcs
200-133-286	FAU55N12R	Without Brake	M12	686N	70kgf	151g	4pcs	72pcs



## TWIN WHEEL CASTER (PLATE TYPE)

LOAD CAPACITY  
50 kgf

## FPU55PS, P



FPU55PR

FPU55PSR



Use of FA55-FIX (P.419) prevents caster swivel.

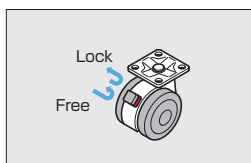

- Wheels absorb vibrations with elastomer covering (rubber) for smooth and quiet movement.
- Caster with high quality polyamide body.
- Excellent durability: chemical / weather / wear resistant.

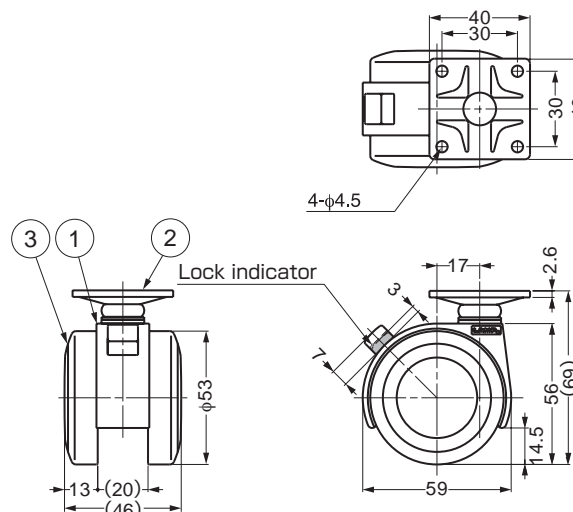

No.	Part Name	Material	Finish/Color
①	Body	Polyamide	Black
②	Plate	Steel	Yellow Zinc Chromate
③	Wheel	Polyamide + Synthetic Rubber	Black

Item Code	Item Name	Spec	Load Capacity(pc)		Weight	Box	Carton
200-133-288	FPU55PSR	With Brake	490N	50kgf	151g	4pcs	72pcs
200-133-293	FPU55PR	Without Brake	490N	50kgf	146g	4pcs	72pcs

## TWIN WHEEL CASTER (THREADED BOLT TYPE)

LOAD CAPACITY  
50 kgf

## FPU55NS, N



FPU55N3R

FPU55N3SR

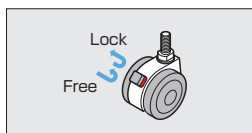

- Wheels absorb vibrations with elastomer covering (rubber) for smooth and quiet movement.
- Caster with high quality polyamide body.
- Excellent durability: chemical / weather / wear resistant.

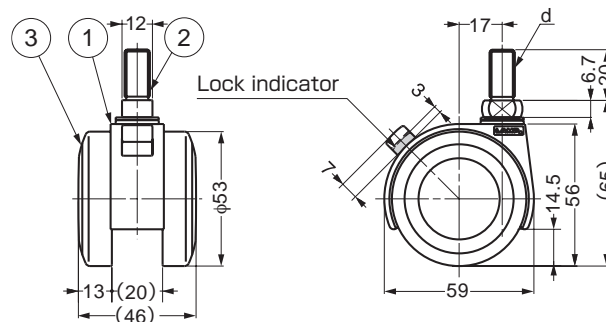

No.	Part Name	Material	Finish/Color
①	Body	Polyamide	Black
②	Threaded Bolt	Steel	Yellow Zinc Chromate
③	Wheel	Polyamide + Synthetic Rubber	Black

Item Code	Item Name	Spec	d	Load Capacity(pc)		Weight	Box	Carton
200-133-289	FPU55N3SR	With Brake	W3/8	490N	50kgf	128g	4pcs	72pcs
200-133-294	FPU55N3R	Without Brake	W3/8	490N	50kgf	123g	4pcs	72pcs
200-133-290	FPU55N10SR	With Brake	M10	490N	50kgf	128g	4pcs	72pcs
200-133-295	FPU55N10R	Without Brake	M10	490N	50kgf	123g	4pcs	72pcs
200-133-291	FPU55N12SR	With Brake	M12	490N	50kgf	128g	4pcs	72pcs
200-133-296	FPU55N12R	Without Brake	M12	490N	50kgf	123g	4pcs	72pcs

# TWIN WHEEL CASTER (PLATE TYPE)

LOAD CAPACITY  
80 kgf

## FA55PS, P

• Light & durable aluminum body construction.



FA55PR

FA55PSR



Use of FA55-FIX (P.419) prevents caster swivel.

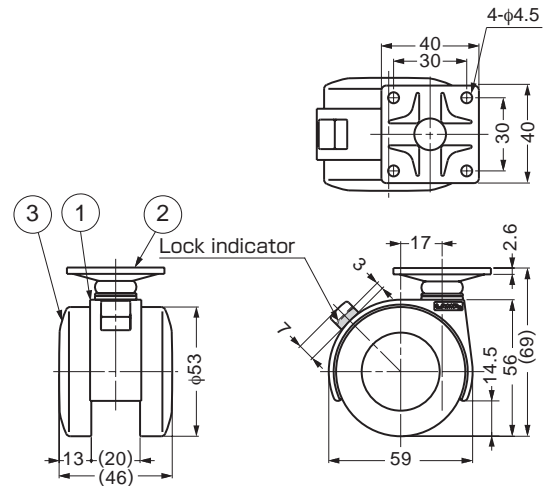
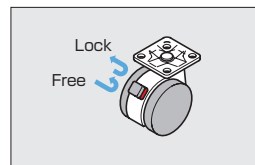

No.	Part Name	Material	Finish/Color
①	Body	Aluminum Alloy	Silver
②	Plate	Steel	Yellow Zinc Chromate
③	Wheel	Polyamide	Black

Item Code	Item Name	Spec	Load Capacity(pc)		Weight	Box	Carton
200-133-258	FA55PSR	With Brake	784N	80kgf	176g	4pcs	72pcs
200-133-263	FA55PR	Without Brake	784N	80kgf	171g	4pcs	72pcs

# TWIN WHEEL CASTER (THREADED BOLT TYPE)

LOAD CAPACITY  
80 kgf

## FA55N

• Light & durable aluminum body construction.



FA55N3R

FA55N3SR

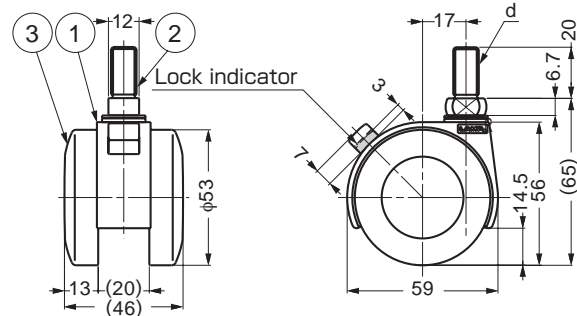
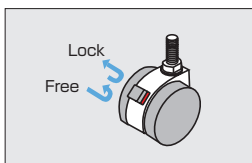

No.	Part Name	Material	Finish/Color
①	Body	Aluminum Alloy	Silver
②	Threaded Bolt	Steel	Yellow Zinc Chromate
③	Wheel	Polyamide	Black

Item Code	Item Name	Spec	d	Load Capacity(pc)		Weight	Box	Carton
200-133-259	FA55N3SR	With Brake	W3/8	784N	80kgf	152g	4pcs	72pcs
200-133-264	FA55N3R	Without Brake	W3/8	784N	80kgf	147g	4pcs	72pcs
200-133-260	FA55N10SR	With Brake	M10	784N	80kgf	152g	4pcs	72pcs
200-133-265	FA55N10R	Without Brake	M10	784N	80kgf	147g	4pcs	72pcs
200-133-261	FA55N12SR	With Brake	M12	784N	80kgf	152g	4pcs	72pcs
200-133-266	FA55N12R	Without Brake	M12	784N	80kgf	147g	4pcs	72pcs

# TWIN WHEEL CASTER (PLATE TYPE) LOAD CAPACITY 50 kgf **FP55PS, P**



FP55PR

FP55PSR

• Light & durable aluminum body construction.

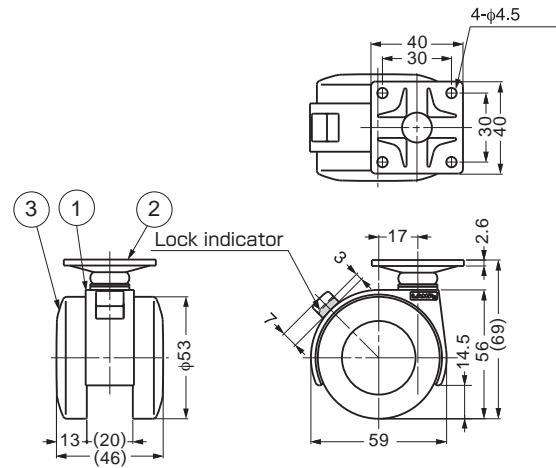

Use of FA55-FIX (P.419) prevents caster swivel.

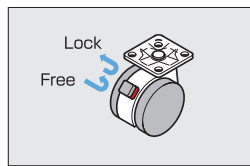

No.	Part Name	Material	Finish/Color
①	Body	Polyamide	Black
②	Plate	Steel	Yellow Zinc Chromate
③	Wheel	Polyamide	Black

Item Code	Item Name	Spec.	Load Capacity(pc)		Weight	Box	Carton
200-133-268	FP55PSR	With Brake	490N	50kgf	148g	4pcs	72pcs
200-133-273	FP55PR	Without Brake	490N	50kgf	144g	4pcs	72pcs

# TWIN WHEEL CASTER (THREADED BOLT TYPE) LOAD CAPACITY 50 kgf **FP55N**



FP55N3R

FP55N3SR

• Caster with high quality polyamide body.  
• Excellent durability: chemical / weather / wear resistant.

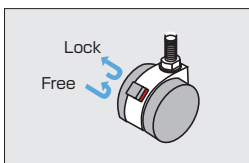
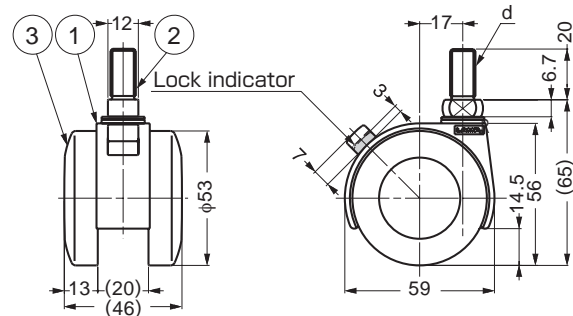

No.	Part Name	Material	Finish/Color
①	Body	Polyamide	Black
②	Threaded Bolt	Steel	Yellow Zinc Chromate
③	Wheel	Polyamide	Black

Item Code	Item Name	Spec.	d	Load Capacity(pc)		Weight	Box	Carton
200-133-269	FP55N3SR	With Brake	W3/8	490N	50kgf	126g	4pcs	72pcs
200-133-274	FP55N3R	Without Brake	W3/8	490N	50kgf	121g	4pcs	72pcs
200-133-270	FP55N10SR	With Brake	M10	490N	50kgf	126g	4pcs	72pcs
200-133-275	FP55N10R	Without Brake	M10	490N	50kgf	121g	4pcs	72pcs
200-133-271	FP55N12SR	With Brake	M12	490N	50kgf	126g	4pcs	72pcs
200-133-276	FP55N12R	Without Brake	M12	490N	50kgf	121g	4pcs	72pcs

## TWIN WHEEL CASTER (PLATE TYPE)

LOAD CAPACITY  
50 kgf

## FA45PS, P

- Light & durable aluminum body construction.

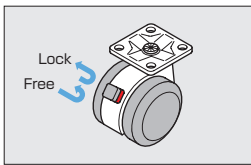
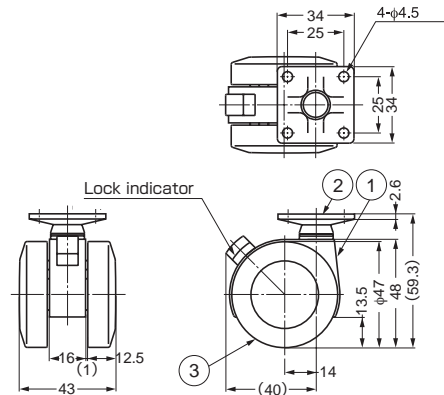

No.	Part Name	Material	Finish/Color
①	Body	Aluminum Alloy	Silver
②	Plate	Steel	Yellow Zinc Chromate
③	Wheel	Polyamide	Black

Item Code	Item Name	Spec.	Load Capacity(pc)	Weight	Box	Carton
200-133-213	FA45PSR	With Brake	490N 50kgf	117g	4pcs	100pcs
200-133-212	FA45PR	Without Brake	490N 50kgf	113g	4pcs	100pcs

## TWIN WHEEL CASTER (THREADED BOLT TYPE)

LOAD CAPACITY  
50 kgf

## FA45NS, N

- Light & durable aluminum body construction.

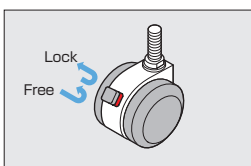
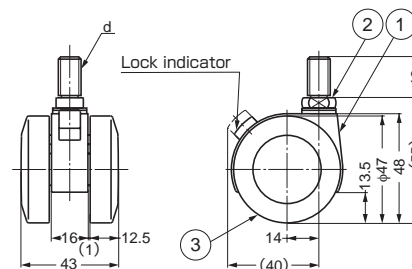

No.	Part Name	Material	Finish/Color
①	Body	Aluminum Alloy	Silver
②	Threaded Bolt	Steel	Yellow Zinc Chromate
③	Wheel	Polyamide	Black

Item Code	Item Name	Spec.	d	Load Capacity(pc)	Weight	Box	Carton
200-133-211	FA45N3SR	With Brake	W3/8	490N 50kgf	100g	4pcs	100pcs
200-133-210	FA45N3R	Without Brake	W3/8	490N 50kgf	97g	4pcs	100pcs
200-133-215	FA45N10SR	With Brake	M10	490N 50kgf	100g	4pcs	100pcs
200-133-209	FA45N10R	Without Brake	M10	490N 50kgf	97g	4pcs	100pcs

# CASTER BRACKET

# FA55-FIX

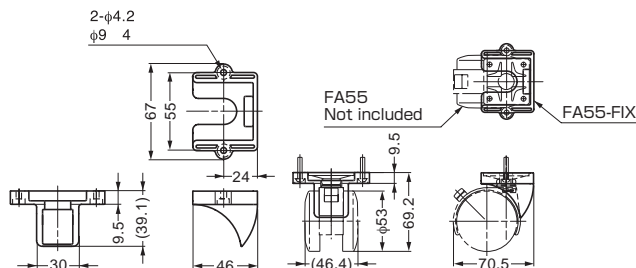

### Application



### Installation

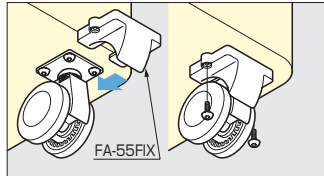

Item Code	Item Name	Material	Color	Weight	Carton
200-012-101	FA55-FIX	Reinforced Nylon	Black	23g	500pcs

# TWIN WHEEL CASTER (PLATE TYPE)

LOAD CAPACITY  
40 kgf

# FP45PS, P

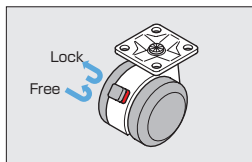

- Caster with high quality polyamide body. Excellent durability: chemical / weather / wear resistant.

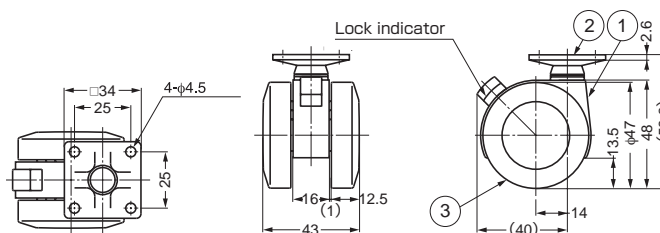

No.	Part Name	Material	Finish/Color
①	Body	Polyamide	Black
②	Plate	Steel	Yellow Zinc Chromate
③	Wheel	Polyamide	Black

Item Code	Item Name	Spec.	Load Capacity(pc)	Weight	Box	Carton
200-133-202	FP45PSR	With Brake	392N 40kgf	98g	4pcs	100pcs
200-133-201	FP45PR	Without Brake	392N 40kgf	94g	4pcs	100pcs

# TWIN WHEEL CASTER (THREADED BOLT TYPE)

LOAD CAPACITY  
40 kgf

# FP45NS, N

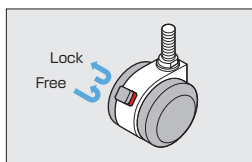

- Caster with high quality polyamide body.
- Excellent durability: chemical / weather / wear resistant.

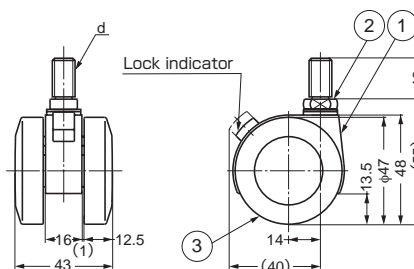

No.	Part Name	Material	Finish/Color
①	Body	Polyamide	Black
②	Threaded Bolt	Steel	Yellow Zinc Chromate
③	Wheel	Polyamide	Black

Item Code	Item Name	Spec.	d	Load Capacity(pc)	Weight	Box	Carton
200-133-204	FP45N3SR	With Brake	W3/8	392N 40kgf	84g	4pcs	100pcs
200-133-203	FP45N3R	Without Brake	W3/8	392N 40kgf	79g	4pcs	100pcs
200-133-206	FP45N10SR	With Brake	M10	392N 40kgf	84g	4pcs	100pcs
200-133-205	FP45N10R	Without Brake	M10	392N 40kgf	79g	4pcs	100pcs

## SURFACE MOUNT BALL CASTER



LOAD CAPACITY  
10-40 kgf

BM

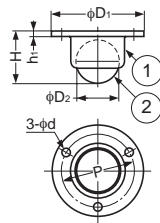

No.	Part Name	Material	Finish
①	Body	Steel (SPCC)	Brass
②	Balls	Steel (SWCH), Steel (SUJ) BM-12only	Polished

Item Code	Item Name	D <sub>1</sub>	D <sub>2</sub>	H	h	P	h <sub>1</sub>	d	Load Capacity(pc)	Weight	Box	Carton
200-013-982	BM-12	28.9	11.9	15.2	21.8	1.7	2.5	98N	10kgf	17.5g	100pcs	800pcs
200-013-983	BM-15	33.7	14.3	19.3	26.6	2.1	2.8	118N	12kgf	31.5g	8pcs	400pcs
200-133-020	BM-20	37	17.5	23	29.5	3	2.7	147N	15kgf	52g	8pcs	400pcs
200-133-021	BM-25	44	22.2	27	36	3.2	2.8	245N	25kgf	93g	4pcs	200pcs
200-133-022	BM-32	57	25.4	32	47	3.2	4.7	392N	40kgf	150g	4pcs	200pcs

## RECESSED BALL CASTER



LOAD CAPACITY  
10-20 kgf

BH

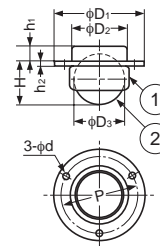

No.	Part Name	Material	Finish
①	Body	Steel (SPCC)	Brass
②	Balls	Steel (SWCH)	Polished

Item Code	Item Name	D <sub>1</sub>	D <sub>2</sub>	D <sub>3</sub>	H	h	P	h <sub>1</sub>	d	Load Capacity(pc)	Weight	Box	Carton
200-133-030	BH-20	30	18.3	17.5	16	5	24	1.6	2	98N	10kgf	35g	8pcs 400pcs
200-133-031	BH-25	41	24.7	22.2	19.5	6	36	2.3	2.6	147N	15kgf	73g	4pcs 200pcs
200-133-032	BH-32	48	29.3	25.4	24.5	6	41	2.3	2.6	196N	20kgf	113g	4pcs 200pcs

## SMALL RECESSED BALL CASTER



LOAD CAPACITY  
8 kgf

BHB

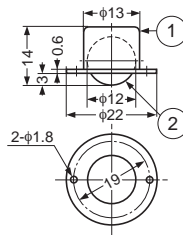

No.	Part Name	Material	Finish
①	Body	Steel	Clear Zinc Chromate
②	Balls	Steel	Polished

Item Code	Item Name	Load Capacity(pc)	Weight	Box	Carton
200-133-040	BHB-12	78.4N	8kgf	11g	100pcs 2,000pcs

## PLASTIC CASTER



LOAD CAPACITY  
25 kgf

NT

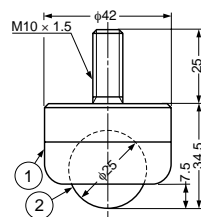

No.	Part Name	Material	Color
①	Body	Polyamide	Brown
②	Ball	Melamine resin	Ivory

Item Code	Item Name	Load Capacity(pc)	Weight	Box	Carton
200-133-010	NT-25	245N	25kgf	58g	20pcs 200pcs

## PLASTIC CASTER



LOAD CAPACITY  
25 kgf

NS

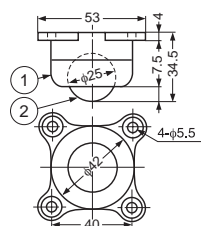

No.	Part Name	Material	Color
①	Body	Polyamide	Brown
②	Ball	Melamine resin	Ivory

Item Code	Item Name	Load Capacity(pc)	Weight	Box	Carton
200-130-422	NS-25	245N	25kgf	43g	20pcs 200pcs

BASE



HS-550



- Can be used with  $\phi 38$  pipe.
- Suitable for using with EX-100N type.

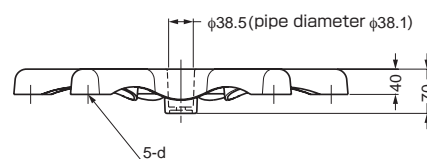
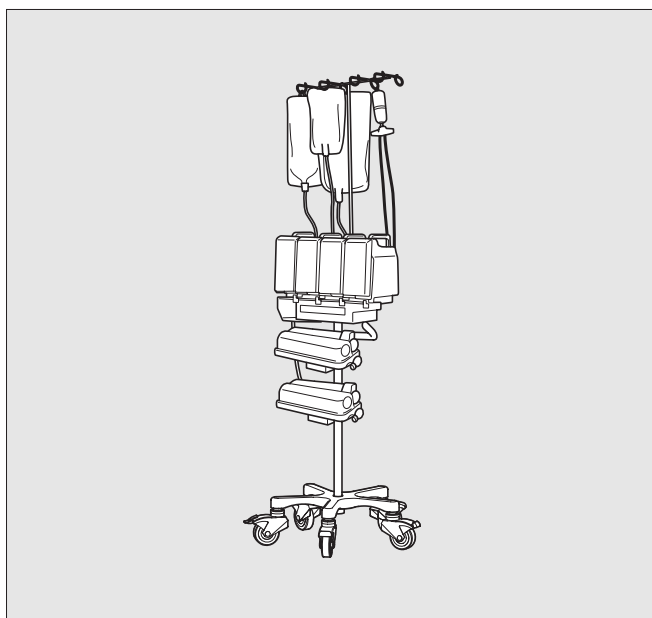
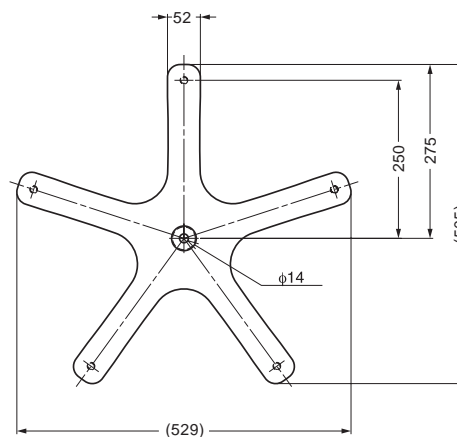
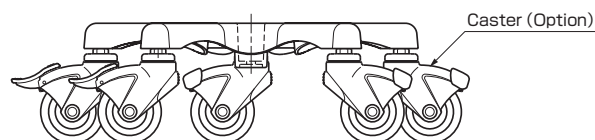

Illustration with EX-100N (P.397)



Item Code	Item Name	Material	Color	d	Carton
200-013-966	HS-550M10	Aluminum Alloy	White	M10	5
200-012-545	HS-550M12	Aluminum Alloy	White	M12	5
200-017-128	HS-550M10M	Aluminum Alloy	Mirror	M10	5
200-014-984	HS-550M12M	Aluminum Alloy	Mirror	M12	5

# BASE



# HO500



- Light aluminum body.
- Can be used for  $\varnothing 50.8$  pipe without optional fixing plate (HOS-Z).
- Can be used for  $\varnothing 25$ ,  $\varnothing 32$ ,  $\varnothing 38$  pipe with optional spacer (HOS) & optional fixing plate (HOS-Z).
- Screw is not included.

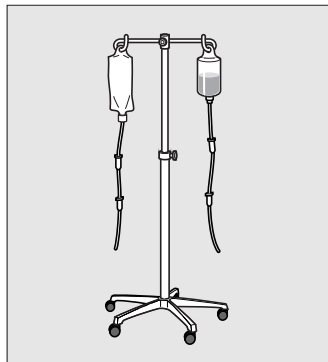
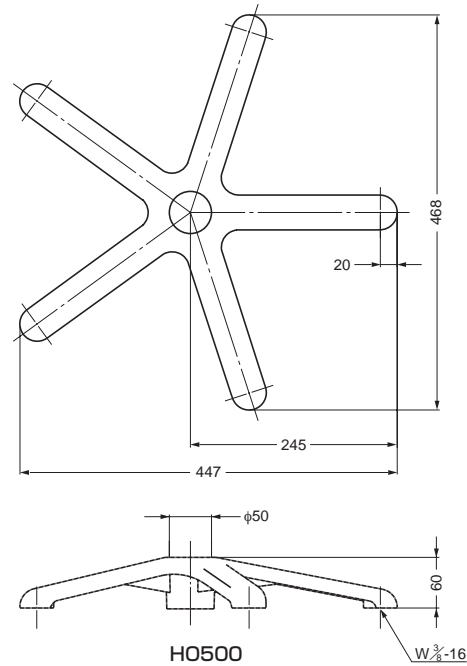

### ■ Spacer (Option)

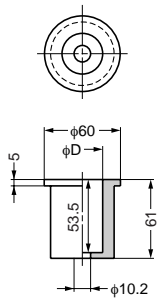

Item Code	Item Name	Material	Color	$\varnothing D$	Carton
200-881-320	HOS-25	Polyamide	Black	25	100
200-881-321	HOS-32	Polyamide	Black	32	100
200-881-322	HOS-38	Polyamide	Black	38	100

### ■ Fixing plate (Option)

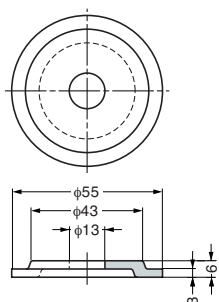

Item Code	Item Name	Material	Finish	Carton
200-881-323	HOS-Z	Stainless Steel (SUS304)	Polished	250

### ■ Base HO500

Item Code	Item Name	Material	Finish	Carton
200-881-326	HO500	Aluminum Alloy	Mirror	5

### ■ Caster (Option)



### ■ Installation

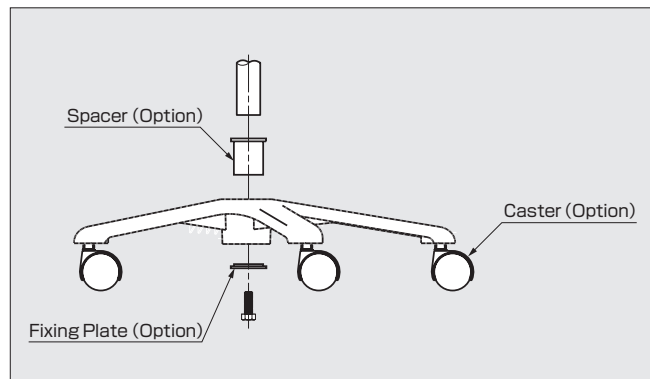



**BASE**

**BJ610**



- Polyamide body resistances to chemicals.
- Can be used for  $\varnothing 50.8$  pipe without optional fixing plate (HOS-Z).
- Can be used for  $\varnothing 25$ ,  $\varnothing 32$ ,  $\varnothing 38$  pipe with optional spacer (HOS) & optional fixing plate (HOS-Z).
- Screw is not included.

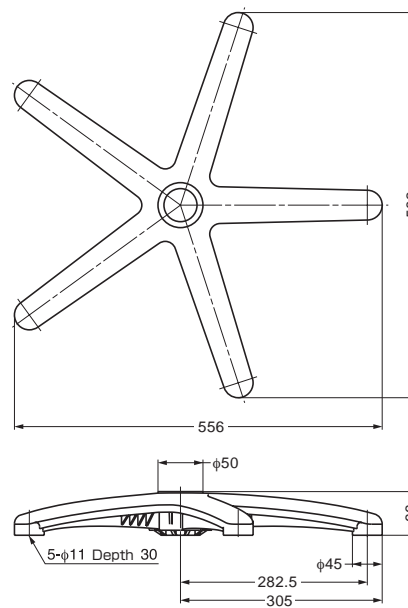
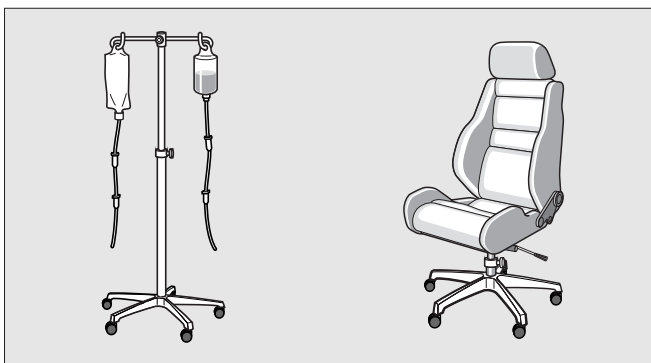

BJ610

■ **Spacer (Option)**

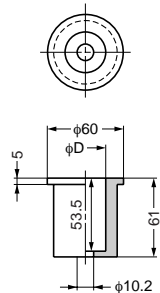

Item Code	Item Name	Material	Color	$\varnothing D$	Carton
200-881-320	HOS-25	Polyamide	Black	25	100
200-881-321	HOS-32	Polyamide	Black	32	100
200-881-322	HOS-38	Polyamide	Black	38	100

■ **Base**

Item Code	Item Name	Material	Color	Carton
200-881-319	BJ610	Reinforced Nylon	Dark Gray	10

■ **Caster (Option)**



Item Code	Item Name	Material	Color	Wheel dia.	H	Carton
200-881-324	CTW38	Nylon/Urethane	Black	$\varnothing 50$	126	100

■ **Fixing plate (Option)**

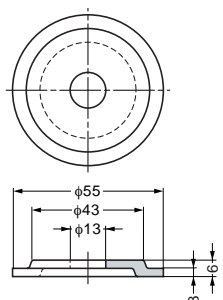

Item Code	Item Name	Material	Finish	Carton
200-881-323	HOS-Z	Stainless Steel (SUS304)	Polished	250

■ **Installation**

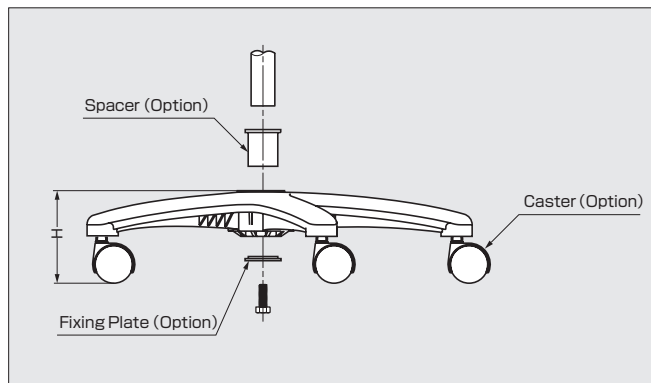



## LEVELING GLIDES

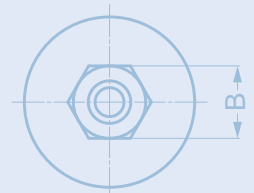
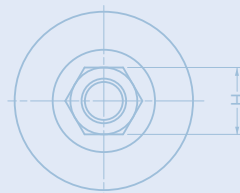



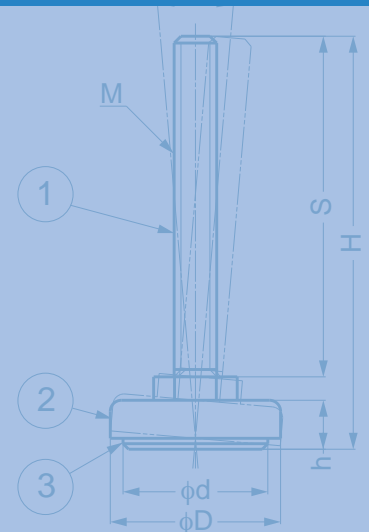
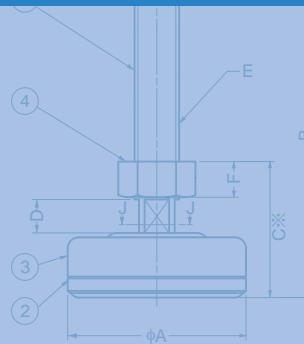



## LEVELING GLIDES



LEVELING GLIDES

Picture	Item Name	Load Capacity (kgf)	Stem Size	Page
	MDSF	35 - 700	M10 - 20	428
	ADHS/ADHSK/ADH	3000 - 4500	M24 - 30	429
	ADPS/ADP	300 - 880	M8 - 20	430
	ADZS/ADZ	-	-	430
	MKPLS	200 - 340	M10 - 16	431
	MKRLS	80 - 100	M10 - 16	431
	MKRL	60 - 80	M10 - 20	432
	TN-S	140	M10	432
	RP	60 - 622	M6 - 14 W5/16 - 3/8	433
	EA	50 - 270	M6 - 12	433
	MKPS	200 - 400	M10 - 12 W3/8	434
	MKRS	40 - 100	M10 - 14 W3/8	434
	MKP	120 - 160	M10 - 14 W3/8	435
	MKR	40 - 80	M10 - 14 W3/8	435
	MN	120 - 160	M8 - 12 W5/16 - 1/2	436

Picture	Item Name	Load Capacity (kgf)	Stem Size	Page
	TG	100 - 180	M8 - 10	436
	SG	120 - 160	M8	436
	AP36	-	-	437
	AD-559	-	-	437
	AS-AJ	-	-	437
	AD-438	-	-	437

STAINLESS  
304  
STEEL

STAINLESS  
430  
STEEL



MDSF

# SWAY FOOT - LEVELING GLIDE

- Sway foot-leveling glide suitable for data center racks, mechanical machines, medical equipments & other type of industrial furniture.
- The base isolation structure absorbs vibrations and shocks.
- Easy installation and cost efficient.
- Can be used on raised floor.



MDSF80-20-100    MDSF58-16-80    MDSF58-10-40

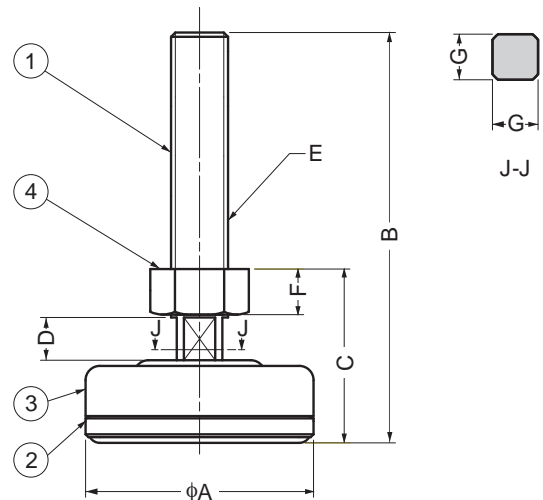
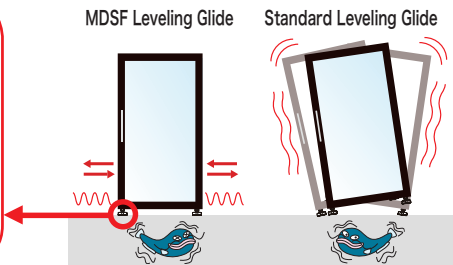
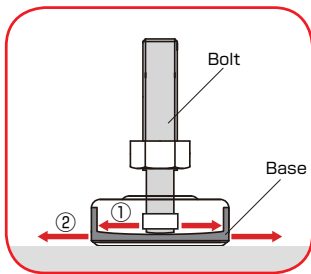
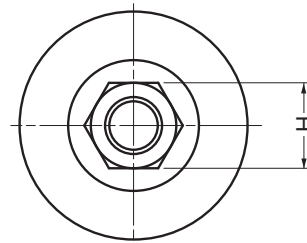

No.	Part Name	Material	Finish
①	Bolt	Steel	Nickel
②	Base	Steel, Fluoroplastic	Nickel
③	Cover	Rubber(NBR70)	—
④	Hex Nut	Steel	Clear Zinc Chromate

Item Name	A	B	C	D	E	F	G	H
MDSF58-10-40	58	65.5	34.5	7.5	M10	8	8	17
MDSF58-16-80	58	114	48	10.5	M16	13	13	24
MDSF80-20-100	80	144	61	15	M20	16	16	30

Item Code	Item Name	Load Capacity (set)		Weight	Max. Application
200-014-807	MDSF58-10-40	343N	35kgf	180g	W410×D630×H390
200-014-805	MDSF58-16-80	5008N	511kgf	300g	W730×D730×H1460
200-014-806	MDSF80-20-100	6860N	700kgf	580g	W1000×D1000×H2000

※ 4 pcs in one set

# HEAVY DUTY LEVELING GLIDE

LOAD CAPACITY  
3000-4500 kgf

# ADHS, ADH



- Adjuster withstanding heavy weight.
  - Three types of models, steel model ADH, stainless steel model ADH, and stainless steel scuffing preventive model ADHSK are available.
  - Model ADHSK allows smoother vertical adjustment for galling preventive treatment.
  - Two types of M24 and M30 screw dia. enables application to large fixture and furniture.
  - Recess for Allen key wrench at the screw head allows effective adjustment.
- Applications: Machine tool, conveyor, semiconductor, LCD production equipment.

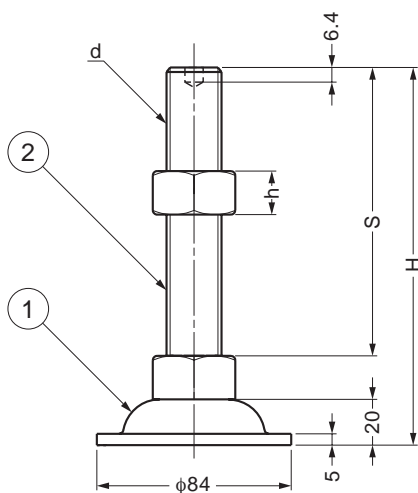
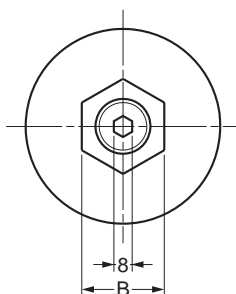

### Application

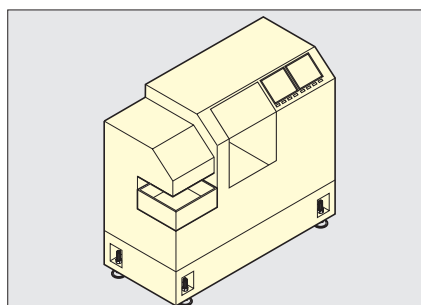

### ADHS (Stainless Steel)

No.	Part Name	Material	Finish
①	Body	Stainless Steel(SUS304)	Satin
②	Threaded Bolt	Stainless Steel(SUS304)	Satin

Item Code	Item Name	H	S	h	B	d	Load Capacity(pc)	Weight	
200-012-534	ADHS-85-24-150	189	150	19	36	M24	29400N	3000kgf	841g
200-012-535	ADHS-85-24-200	239	200	19	36	M24	34300N	3500kgf	1091g
200-012-536	ADHS-85-30-150	194	150	24	46	M30	39200N	4000kgf	1461g
200-012-537	ADHS-85-30-200	244	200	24	46	M30	44100N	4500kgf	1685g

### ADHSK (Stainless Steel · Scuffing preventive treated)

No.	Part Name	Material	Finish
①	Body	Stainless Steel(SUS304)	Satin
②	Threaded Bolt	Stainless Steel(SUS304)	Baking Finish

Item Code	Item Name	H	S	h	B	d	Load Capacity(pc)	Weight	
200-012-538	ADHS-85-24-150K	189	150	19	36	M24	29400N	3000kgf	951g
200-012-539	ADHS-85-24-200K	239	200	19	36	M24	34300N	3500kgf	1092g
200-012-540	ADHS-85-30-150K	194	150	24	46	M30	39200N	4000kgf	1558g
200-012-541	ADHS-85-30-200K	244	200	24	46	M30	44100N	4500kgf	1690g

### ADH (Steel)

No.	Part Name	Material	Finish
①	Body	Steel	Clear Zinc Chromate
②	Threaded Bolt	Steel	Clear Zinc Chromate

Item Code	Item Name	H	S	h	B	d	Load Capacity(pc)	Weight	
200-012-530	ADH-85-24-150	189	150	19	36	M24	29400N	3000kgf	945g
200-012-531	ADH-85-24-200	239	200	19	36	M24	34300N	3500kgf	1081g
200-012-532	ADH-85-30-150	194	150	24	46	M30	39200N	4000kgf	1450g
200-012-533	ADH-85-30-200	244	200	24	46	M30	44100N	4500kgf	1682g

# STAINLESS STEEL LEVELING GLIDE



LOAD CAPACITY  
300-880 kgf

STAINLESS  
304  
STEEL

## ADPS



- Nut on bottom of glide allows easy installation and height adjustment with socket wrench.

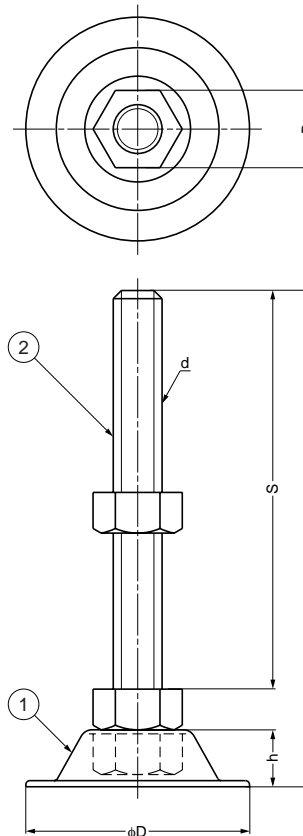

### Application

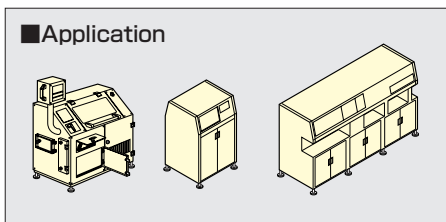

### ADPS (Stainless Steel)

No.	Part Name	Material	Finish
①	Body	Stainless Steel (SUS304)	Satin
②	Threaded Bolt	Stainless Steel (SUS304)	Satin

Item Code	Item Name	D	H	h	S	B	d	Load Capacity(pc)	Weight	Carton	
200-141-182	ADPS37-8-60	37	76	10.5	60	13	M8×1.25	2940N	300kgf	56g	200pcs
200-141-183	ADPS37-10-50	37	67.5	10.5	50	17	M10×1.5	2940N	300kgf	78g	200pcs
200-141-184	ADPS55-12-100	55	122	14	100	19	M12×1.75	2940N	300kgf	174g	100pcs
200-141-185	ADPS55-12-120	55	142	14	120	19	M12×1.75	2940N	300kgf	184g	80pcs
200-141-186	ADPS55-12-150	55	172	14	150	19	M12×1.75	2940N	300kgf	210g	70pcs
200-141-187	ADPS75-16-100	75	128	18	100	24	M16×2	5488N	560kgf	318g	50pcs
200-141-188	ADPS75-16-130	75	158	18	130	24	M16×2	5488N	560kgf	358g	40pcs
200-141-189	ADPS75-16-150	75	178	18	150	24	M16×2	5488N	560kgf	382g	30pcs
200-141-190	ADPS75-16-180	75	208	18	180	24	M16×2	5488N	560kgf	426g	30pcs
200-141-191	ADPS75-20-100	75	131	18	100	30	M20×2.5	8624N	880kgf	490g	40pcs
200-141-192	ADPS75-20-130	75	161	18	130	30	M20×2.5	8624N	880kgf	553g	30pcs
200-141-193	ADPS75-20-150	75	181	18	150	30	M20×2.5	8624N	880kgf	593g	30pcs
200-141-194	ADPS75-20-180	75	211	18	180	30	M20×2.5	8624N	880kgf	655g	25pcs

# STAINLESS STEEL LEVELING GLIDE WASHER

## ADZS/ADZ

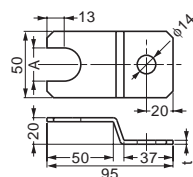

Item Code	Item Name	A	t	Material	Finish	Weight	Box	Carton
200-141-243	ADZS-M12	19	3	Stainless Steel(SUS304)	Polished	104g	50pcs	100pcs
200-141-244	ADZS-M16	24.5	3	Stainless Steel(SUS304)	Polished	100g	50pcs	100pcs
200-141-245	ADZS-M20	30.5	3	Stainless Steel(SUS304)	Polished	96g	50pcs	100pcs
200-141-240	ADZ-M12	19	3.2	Steel	Clear Zinc Chromate	115g	50pcs	100pcs
200-141-241	ADZ-M16	24.5	3.2	Steel	Clear Zinc Chromate	110g	50pcs	100pcs
200-141-242	ADZ-M20	30.5	3.2	Steel	Clear Zinc Chromate	106g	50pcs	100pcs



# STAINLESS STEEL LONG-STEM LEVELING GLIDE



# MKPLS



- Double structure of cover/bolt and base allows easy height adjustment without lifting the leg.
- Swivels approximately 10° to compensate for uneven floors.
- 304 stainless steel construction is ideal for humid environments or applications where corrosion is an issue.

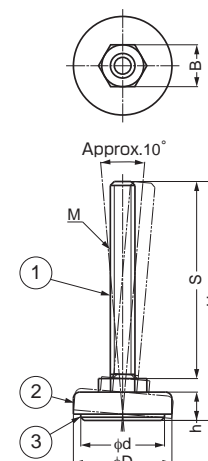

No.	Part Name	Material	Finish
①	Body	Stainless Steel	Satin
②	Cover	Stainless Steel (SUS304)	Satin
③	Base	Stainless Steel (SUS304)	Plain

Item Code	Item Name	M	φ D	φ d	H	h	S	B	Load Capacity(pc)	Weight	Box	Carton	
200-130-347	MKPLS-32-10-80	M10×1.5	32	27	96	10.5	80	17	1960N	200kgf	79g	30pcs	240pcs
200-141-336	MKPLS-40-12-80	M12×1.75	40	34	97	11.5	80	17	2940N	300kgf	125g	30pcs	240pcs
200-141-337	MKPLS-50-12-80	M12×1.75	50	44	97	11.5	80	17	3332N	340kgf	150g	20pcs	160pcs
200-141-338	MKPLS-50-16-78	M16×2	50	44	100	11.5	78.5	24	3136N	320kgf	220g	15pcs	120pcs

# STAINLESS STEEL LONG-STEM LEVELING GLIDE



# MKRLS



- Double structure of cover/bolt and base allows easy height adjustment without lifting the leg.
- Swivels approximately 10° to compensate for uneven floors.
- Leveling glide with elastomer base prevents skidding.

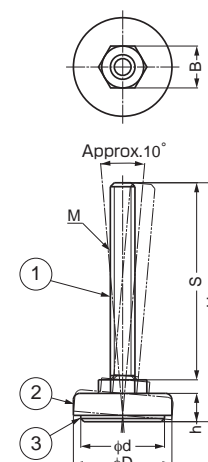

No.	Part Name	Material	Finish/Color
①	Body	Stainless Steel	Satin
②	Cover	Stainless Steel (SUS304)	Satin
③	Base	Synthetic Rubber	Black

Item Code	Item Name	M	φ D	φ d	H	h	S	B	Load Capacity(pc)	Weight	Box	Carton	
200-130-348	MKRLS-32-10-80	M10×1.5	32	27	96	11	80	17	784N	80kgf	76g	30pcs	240pcs
200-141-339	MKRLS-40-12-80	M12×1.75	40	34	97	11.5	80	17	784N	80kgf	120g	30pcs	240pcs
200-141-340	MKRLS-50-12-80	M12×1.75	50	44	97	11.5	80	17	980N	100kgf	140g	20pcs	160pcs
200-141-341	MKRLS-50-16-78	M16×2	50	44	100	11.5	78.5	24	784N	80kgf	215g	15pcs	120pcs

# LEVELING GLIDE

LOAD CAPACITY  
60-80 kgf

## MKRL



- Double structure of cover/bolt and base allow easy height adjustment without lifting the leg.
- Easy installation with hex socket on the bottom for allen key.

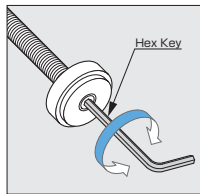
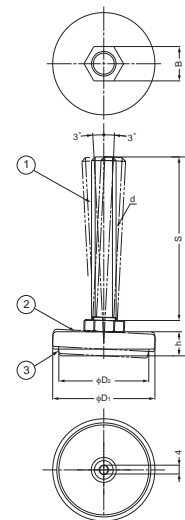

Height can be adjusted by 4mm hex key (not included)

No.	Part Name	Material	Finish/Color
①	Body	Steel	Black Zinc Chromate
②	Cover	Steel	Black Zinc Chromate
③	Base	Synthetic Rubber	Black

Item Code	Item Name	φ D1	φ D2	H	h	S	B	d	Load Capacity(pc)	Weight	Box	Carton	
200-141-159	MKRL-32-10-80B6	32	27	95.8	10.8	80	17	M10×1.5	588N	60kgf	77g	30pcs	300pcs
200-147-014	MKRL-32-12-66B6	32	27	81.8	10.8	66	17	M12×1.75	735N	75kgf	85g	30pcs	300pcs
200-141-120	MKRL-32-12-80B6	32	27	95.8	10.8	80	17	M12×1.75	588N	60kgf	94g	30pcs	300pcs
200-141-160	MKRL-40-10-80B6	40	34	96.2	11.2	80	17	M10×1.5	588N	60kgf	95g	25pcs	250pcs
200-141-115	MKRL-40-12-32B6	40	34	48.2	11.2	32	17	M12×1.75	588N	60kgf	78g	30pcs	300pcs
200-141-110	MKRL-40-12-43B6	40	34	59.2	11.2	43	17	M12×1.75	588N	60kgf	86g	25pcs	250pcs
200-141-124	MKRL-40-12-55B6	40	34	71.2	11.2	55	17	M12×1.75	588N	60kgf	94g	25pcs	250pcs
200-149-111	MKRL-40-12-80B6	40	34	96.2	11.2	80	17	M12×1.75	588N	60kgf	111g	25pcs	250pcs
200-141-111	MKRL-40-12-120B6	40	34	136.2	11.2	120	17	M12×1.75	588N	60kgf	142g	15pcs	150pcs
200-141-161	MKRL-50-10-80B6	50	44	96.8	11.8	80	17	M10×1.5	588N	60kgf	120g	20pcs	200pcs
200-149-112	MKRL-50-12-80B6	50	44	96.8	11.8	80	17	M12×1.75	588N	60kgf	136g	20pcs	200pcs
200-141-112	MKRL-50-12-120B6	50	44	136.8	11.8	120	17	M12×1.75	588N	60kgf	169g	10pcs	100pcs
200-149-113	MKRL-50-16-78B6	50	44	100.3	11.8	78.5	24	M16×2	784N	80kgf	214g	15pcs	120pcs
200-141-113	MKRL-70-20-101B6	70	64	124.5	11.5	101	30	M20×2.5	784N	80kgf	448g	8pcs	64pcs

# LEVELING GLIDE



LOAD CAPACITY  
140 kgf

## TN-S

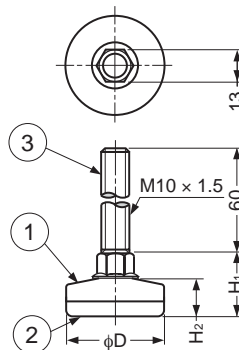

No.	Part Name	Material	Finish
①	Body	Steel	Chrome
②	Base	Polypropylene	Natural
③	Threaded Bolt	Steel	Clear Zinc Chromate

Item Code	Item Name	φ D	H1	H2	Load Capacity(pc)	Weight	Box	Carton	
200-140-249	TN-25S	25	21	12	1372N	140kgf	50pcs	500pcs	
200-140-250	TN-35S	35	22.5	13.5	1372N	140kgf	60g	30pcs	300pcs
200-140-251	TN-45S	43.5	22.5	13.5	1372N	140kgf	70g	20pcs	200pcs

# LEVELING GLIDE



LOAD CAPACITY  
60-622 kgf

RP



- Swivels approximately 30° to compensate for uneven floors.

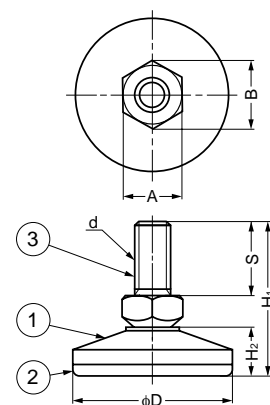
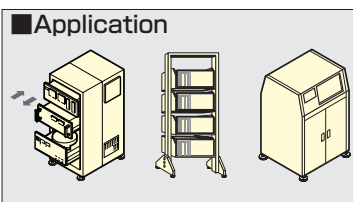
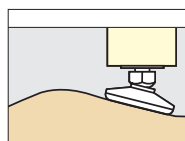
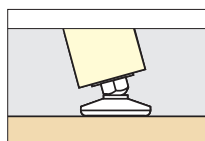

Item Code	Item Name	A	D	B	H1	S	H2	d	Load Capacity(pc)	Weight	Box	Carton
200-140-028	RP-25M6-G	8	25	9.2	31	14	9.7	M6	588N	60kgf	11g	50pcs / 500pcs
200-140-029	RP-30M8-G	10	30	11.5	37.5	19	11.2	M8	1078N	110kgf	21g	35pcs / 350pcs
200-140-023	RP-30N25	10	30	11.5	37.5	19	11.2	W5/16	1078N	110kgf	21g	35pcs / 350pcs
200-140-031	RP-40M10-G	13	40	15	42.5	20	13.7	M10	1568N	160kgf	38g	25pcs / 250pcs
200-140-032	RP-40N3-G	13	40	15	42.5	20	13.7	W3/8	1568N	160kgf	38g	25pcs / 250pcs
200-140-033	RP-50M12-G	17	50	19.6	51	25	16	M12	3136N	320kgf	70g	15pcs / 150pcs
200-140-027	RP-70M14-G	19	70	22	66.5	30	24.7	M14	6100N	622kgf	150g	10pcs / 100pcs

No.	Part Name	Material	Finish/Color
①	Body	Stainless Steel (SUS304)	Satin
②	Base	Polyamide	Natural
③	Threaded Bolt	Steel	Clear Zinc Chromate

# LEVELING GLIDE (PARTS SEPARABLE)



LOAD CAPACITY  
50-270 kgf

EA



- Bolt swivels to compensate for uneven floors.
- Parts can be easily separated for recycling purpose.

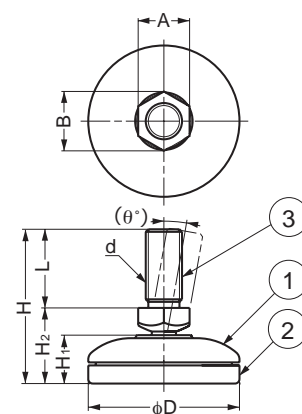
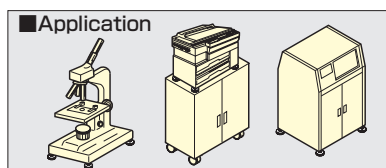
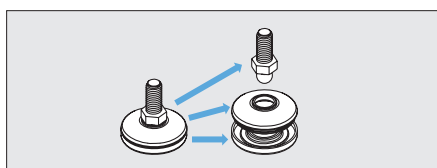

No.	Part Name	Material	Finish/Color
①	Body	ABS Plastic	Dark Grey
②	Base	ABS Plastic	Dark Grey
③	Threaded Bolt	Steel	Clear Zinc Chromate

Item Code	Item Name	A	B	D	H	H1	H2	L	θ°	d	Load Capacity(pc)	Weight	Box	Carton
200-140-911	EA-25M6	8	9.2	25	31	8.5	14	17	10	M6	490N	50kgf	10g	120pcs / 1200pcs
200-140-912	EA-30M8	10	11.5	30	37.5	10.5	17	20.5	15	M8	980N	100kgf	20g	80pcs / 800pcs
200-140-913	EA-40M10	13	15	40	42.5	13	20.5	22	12.5	M10	1274N	130kgf	32g	40pcs / 400pcs
200-140-910	EA-50M12	17	19.6	50	51	16	25	26	10	M12	2646N	270kgf	60g	20pcs / 200pcs

# STAINLESS STEEL LEVELING GLIDE



## MKPS



- Double structure of cover/bolt and base allows easy height adjustment without lifting the leg.
- Swivels approximately 10° to compensate for uneven floors.
- 304 stainless steel constructions is ideal for humid environments or applications where corrosion is an issue.

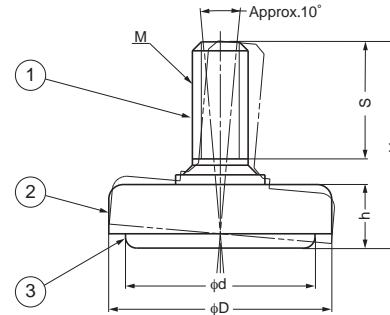

No.	Part Name	Material	Finish
①	Body	Stainless Steel	Satin
②	Cover	Stainless Steel (SUS304)	Satin
③	Base	Stainless Steel (SUS304)	Plain

Item Code	Item Name	M	D	d	H	h	S	Load Capacity(pc)	Weight	Box	Carton
200-141-320	MKPS-32M10	M10	32	27	36	11	21	1960N 200kgf	50g	60pcs	480pcs
200-141-321	MKPS-32N3	W3/8	32	27	36	11	21	1960N 200kgf	50g	60pcs	480pcs
200-141-322	MKPS-40M10	M10	40	34	37	11.4	21	3136N 320kgf	70g	40pcs	320pcs
200-141-323	MKPS-40N3	W3/8	40	34	37	11.4	21	3136N 320kgf	70g	40pcs	320pcs
200-141-324	MKPS-50M10	M10	50	44	37.5	11.5	21	3528N 360kgf	95g	30pcs	240pcs
200-141-325	MKPS-50N3	W3/8	50	44	37.5	11.5	21	3528N 360kgf	95g	30pcs	240pcs
200-141-326	MKPS-60M12	M12	60	54	51.5	11.5	35	3920N 400kgf	140g	15pcs	120pcs

# STAINLESS STEEL LEVELING GLIDE (W/RUBBER PAD)



## MKRS



- Leveling glide with elastomer base prevents skidding.
- Double structure of cover/bolt and base allows easy height adjustment without lifting the leg.
- Swivels approximately 10° to compensate for uneven floors.
- 304 stainless steel constructions is ideal for humid environments or applications where corrosion is an issue.

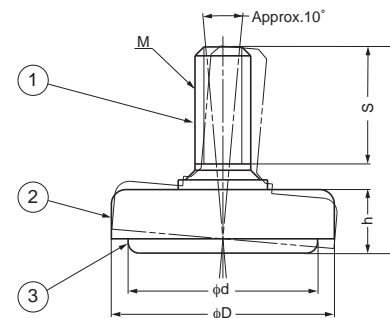

No.	Part Name	Material	Finish/Color
①	Body	Stainless Steel	Satin
②	Cover	Stainless Steel (SUS304)	Satin
③	Base	Synthetic Rubber	Black

Item Code	Item Name	M	D	d	H	h	S	Load Capacity(pc)	Weight	Box	Carton
200-141-328	MKRS-32M10	M10	32	27	36	11	21	392N 40kgf	50g	60pcs	480pcs
200-141-329	MKRS-32N3	W3/8	32	27	36	11	21	392N 40kgf	50g	60pcs	480pcs
200-141-330	MKRS-40M10	M10	40	34	37	11.4	21	784N 80kgf	70g	40pcs	320pcs
200-141-331	MKRS-40N3	W3/8	40	34	37	11.4	21	784N 80kgf	70g	40pcs	320pcs
200-141-332	MKRS-50M10	M10	50	44	37.5	11.5	21	980N 100kgf	90g	30pcs	240pcs
200-141-333	MKRS-50N3	W3/8	50	44	37.5	11.5	21	980N 100kgf	90g	30pcs	240pcs
200-141-334	MKRS-60M12	M12	60	54	51.5	11.5	35	980N 100kgf	150g	15pcs	120pcs
200-141-335	MKRS-70M14	M14	70	64	51.5	11.5	35	980N 100kgf	200g	15pcs	120pcs

# LEVELING GLIDE

LOAD CAPACITY  
120-160 kgf

MKP



- Double structure of cover/bolt and base allows easy height adjustment without lifting the leg.
- Swivels approximately 10° to compensate for uneven floors.

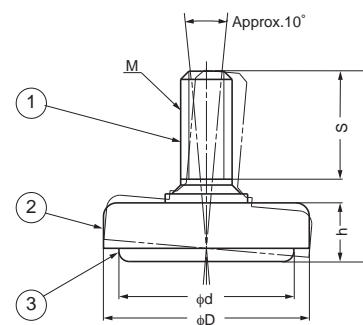

No.	Part Name	Material	Finish/Color
①	Body	Steel	Chrome
②	Cover	Steel	Chrome
③	Base	Steel	Chrome

### Installation

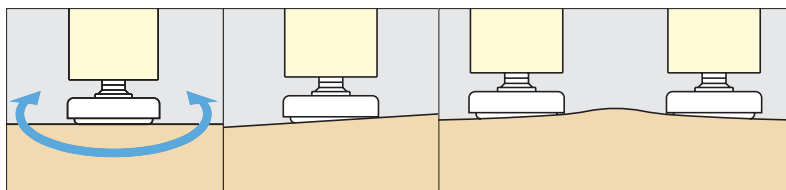

Item Code	Item Name	M	D	d	H	h	S	Load Capacity(pc)	Weight	Box	Carton	
200-141-503	MKP-32M10	M10	32	27	36	11	21	1568N	160kgf	44g	80pcs	480pcs
200-140-090	MKP-32N3	W3/8	32	27	36	11	21	1568N	160kgf	44g	80pcs	480pcs
200-140-094	MKP-40M10	M10	40	34	37	11.4	21	1568N	160kgf	65g	50pcs	300pcs
200-140-091	MKP-40N3	W3/8	40	34	37	11.4	21	1568N	160kgf	65g	50pcs	300pcs
200-140-095	MKP-50M10	M10	50	44	37.5	11.5	21	1176N	120kgf	90g	20pcs	120pcs
200-140-092	MKP-50N3	W3/8	50	44	37.5	11.5	21	1176N	120kgf	90g	20pcs	120pcs
200-141-100	MKP-60M12	M12	60	54	51.5	11.5	35	1568N	160kgf	155g	15pcs	120pcs
200-141-101	MKP-70M14	M14	70	64	51.5	11.5	35	1568N	160kgf	195g	15pcs	120pcs

# LEVELING GLIDE (W/RUBBER PAD)

LOAD CAPACITY  
40-80 kgf

MKR



- Leveling glide with elastomer base prevents skidding.
- Double structure of cover/bolt and base allows easy height adjustment without lifting the leg.
- Swivels approximately 10° to compensate for uneven floors.

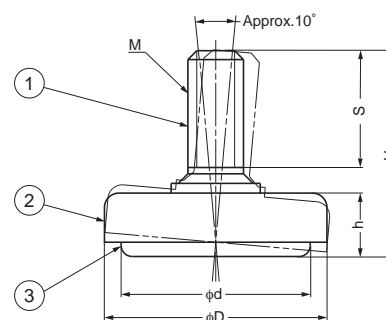

No.	Part Name	Material	Finish/Color
①	Body	Steel	Chrome
②	Cover	Steel	Chrome
③	Base	Synthetic Rubber	Black

Item Code	Item Name	M	D	d	H	h	S	Load Capacity(pc)	Weight	Box	Carton	
200-141-513	MKR-32M10	M10	32	27	36	11	21	392N	40kgf	41g	80pcs	480pcs
200-140-096	MKR-32N3	W3/8	32	27	36	11	21	392N	40kgf	41g	80pcs	480pcs
200-141-514	MKR-40M10	M10	40	34	37	11.4	21	588N	60kgf	60g	50pcs	300pcs
200-140-097	MKR-40N3	W3/8	40	34	37	11.4	21	588N	60kgf	60g	50pcs	300pcs
200-141-515	MKR-50M10	M10	50	44	37.5	11.5	21	588N	60kgf	87g	20pcs	120pcs
200-140-098	MKR-50N3	W3/8	50	44	37.5	11.5	21	588N	60kgf	87g	20pcs	120pcs
200-141-103	MKR-60M12	M12	60	54	51.5	11.5	35	784N	80kgf	150g	15pcs	120pcs
200-141-102	MKR-70M14	M14	70	64	51.5	11.5	35	784N	80kgf	215g	15pcs	120pcs

# LEVELING GLIDE



LOAD CAPACITY  
120-400 kgf

MN



- Easy installation with phillips screw driver.
- Swivels approximately 8° to compensate for uneven floors.
- White polypropylene base prevents floor damage.

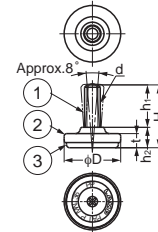

No.	Part Name	Material	Finish/Color
①	Threaded Bolt	Steel	Chrome
②	Cover	Stainless Steel (SUS304)	-
③	Base	Polypropylene	Natural

Item Code	Item Name	D	H	h1	h2	t	d	Load Capacity(pc)	Weight	Box	Carton
200-140-401	MN-25M8	25	40	27	13	9	M8	1176N	120kgf	26g	100pcs 600pcs
200-140-400	MN-25N2.5	25	40	27	13	9	W5/16	1176N	120kgf	26g	100pcs 600pcs
200-140-403	MN-32M10	32	40	27	13	9	M10	1568N	160kgf	34g	80pcs 480pcs
200-140-402	MN-32N3	32	40	27	13	9	W3/8	1568N	160kgf	34g	80pcs 480pcs
200-140-405	MN-36M10	36	40	27	13	9	M10	1568N	160kgf	39g	60pcs 360pcs
200-140-404	MN-36N3	36	40	27	13	9	W3/8	1568N	160kgf	39g	60pcs 360pcs
200-140-407	MN-40M10	40	40	27	13	9	M10	1568N	160kgf	42g	50pcs 300pcs
200-140-406	MN-40N3	40	40	27	13	9	W3/8	1568N	160kgf	42g	50pcs 300pcs
200-140-409	MN-50M12	50	50	34	16	11	M12	3920N	400kgf	77g	20pcs 120pcs
200-140-408	MN-50N4	50	50	34	16	11	W1/2	3920N	400kgf	77g	20pcs 120pcs

# LEVELING GLIDE



LOAD CAPACITY  
100-180 kgf

TG



TG-40

TG-30WT

TG-20



No.	Part Name	Material	Finish/Color
①	Body	Polyamide	Dark Grey · White
②	Threaded Bolt	Steel	Clear Zinc Chromate

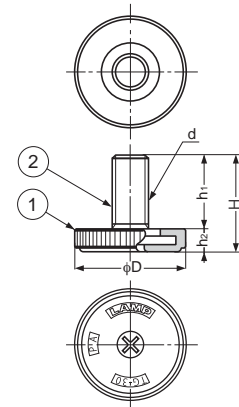

Item Code	Item Name	Finish/Color	D	H	h1	h2	d	Load Capacity(pc)	Weight	Box	Carton
200-140-240	TG-20	Dark Grey	20	21	15	6	M8	980N	100kgf	11g	120pcs 720pcs
200-936-848	TG-20WT	White	20	21	15	6	M8	980N	100kgf	11g	120pcs 720pcs
200-142-501	TG-30	Dark Grey	30	26	20	6	M10	1470N	150kgf	25g	100pcs 600pcs
200-936-849	TG-30WT	White	30	26	20	6	M10	1470N	150kgf	25g	100pcs 600pcs
200-142-520	TG-40	Dark Grey	40	26	20	6	M10	1764N	180kgf	36g	60pcs 360pcs
200-936-850	TG-40WT	White	40	26	20	6	M10	1764N	180kgf	36g	60pcs 360pcs

# SYSTEM FOOT

LOAD CAPACITY  
120-160 kgf

SG



SG-40M8

SG-32M8

- Swivels approximately 20° to compensate for uneven floors.

■ Installation

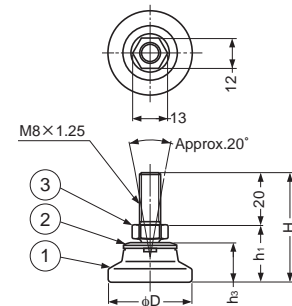
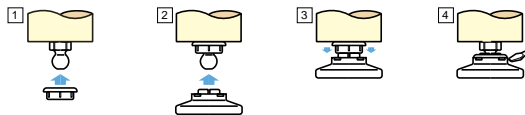

No.	Part Name	Material	Finish/Color
①	Base	Polyacetal	Dark Grey
②	Cap	Polyamide	Dark Grey
③	Body	Steel	Black Zinc

Item Code	Item Name	D	H	h1	h3	Load Capacity(pc)	Weight	Box	Carton
200-142-506	SG-32M8	32	42	22	15.5	1176N	120kgf	25g	60pcs 480pcs
200-142-504	SG-40M8	40	42.5	22.5	16	1568N	160kgf	30g	35pcs 280pcs

# STAINLESS STEEL GLIDE BASE



AP36

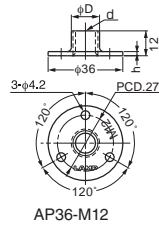

Item Code	Item Name	Material	Finish	d	φD	h	Weight	Box	Carton
200-140-501	AP36-M8	Stainless Steel (SUS304)	Barrel Polishing	M8	(9.8)	1.5	13g	100pcs	1,000pcs
200-140-502	AP36-M10	Stainless Steel (SUS304)	Barrel Polishing	M10	(11.5)	1.5	13g	100pcs	1,000pcs
200-140-503	AP36-N3	Stainless Steel (SUS304)	Barrel Polishing	W3/8	(10.9)	1.5	14g	100pcs	1,000pcs
200-140-504	AP36-M12	Stainless Steel (SUS304)	Barrel Polishing	M12	(14.2)	2	19g	80pcs	800pcs

# GLIDE BASE



AD-559

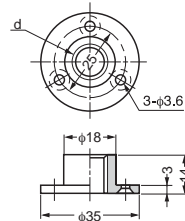

Item Code	Item Name	Material	Finish	d	Weight	Box	Carton
200-141-310	AD-559M12	Zinc Alloy	Clear Zinc Chromate	M12	26.5g	100pcs	400pcs
200-141-311	AD-559M14	Zinc Alloy	Clear Zinc Chromate	M14	23.5g	100pcs	400pcs
200-140-073	AD-559U1/2	Zinc Alloy	Clear Zinc Chromate	1/2-20UNF	24.6g	100pcs	400pcs

# GLIDE BASE



AS-AJ

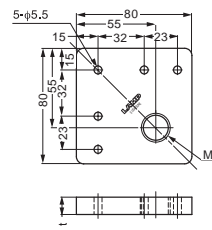

Item Code	Item Name	M	t	Material	Finish	Weight
200-140-455	AS-AJ-M10	M10	6	Stainless Steel (SUS430)	Polished	279g
200-140-456	AS-AJ-M12	M12	6			279g
200-140-457	AS-AJ-M16	M16	9			414g

### Installation

40×40mm Aluminum Frame

30×30mm Aluminum Frame

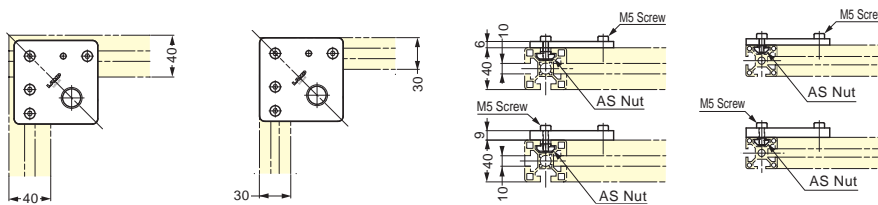

### Installation

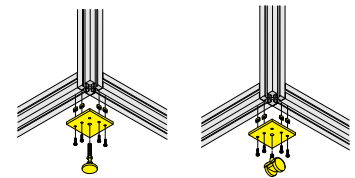

# BASE



AD-438



• Leveling glide guide allows easy installation.

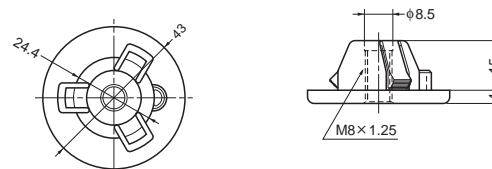

### Installation

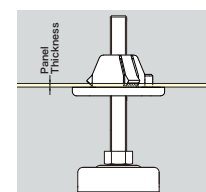

### Bore Dimensions

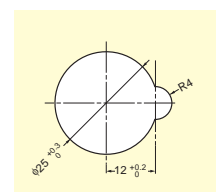

Item Code	Item Name	Material	Color	Panel Thickness	Load Capacity (pc)	Weight
200-014-819	AD-438	Polyacetal	Grey	0.8 ~ 1.6	490N 50kgf	10g





LOCKS

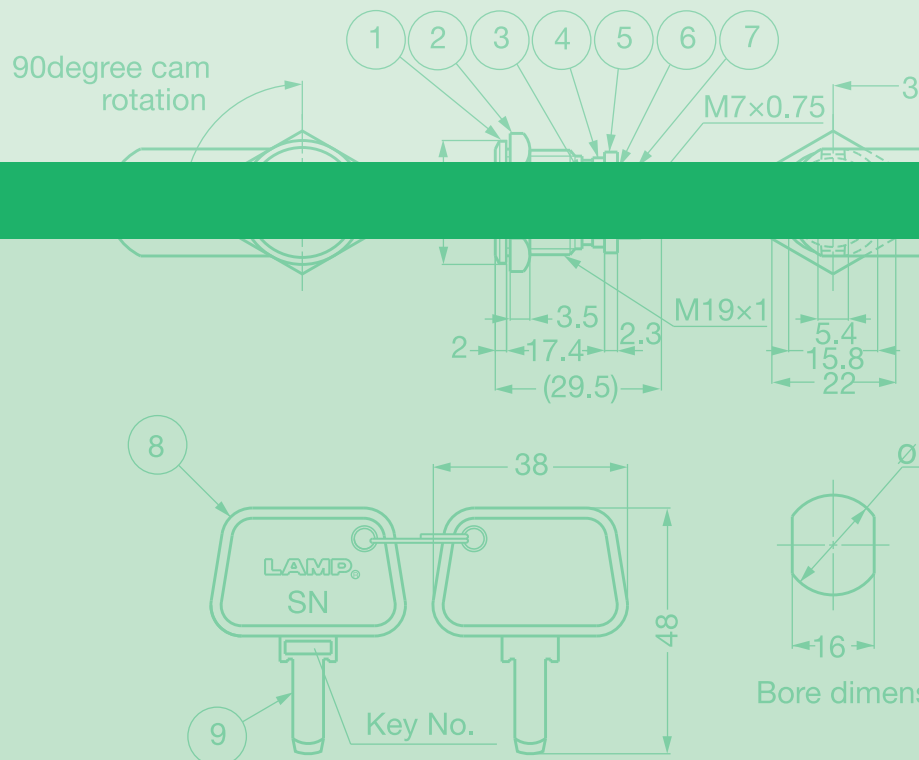

LOCKS

**CAM LOCKS**

Picture	Item Name	Key Changes	Master Key Option	Page
	NO990	40000	-	441
	DCY-34	2000	●	441
	900	1 Million	●	442
	3800S	300	●	442
	CLI-31	108	-	443
	SN-711-8	1500	-	443
	NAL-S	100	-	444
	NAL	5000	-	444

**PUSH LOCKS**

Picture	Item Name	Key Changes	Master Key Option	Page
	2100B	12	-	445
	2110B	12	-	445
	2150B	24	-	446
	6300	96	-	446

**CABINET LOCKS**

Picture	Item Name	Key Changes	Master Key Option	Page
	2200QL	300	●	447
	3810S	300	●	447

**GLASS LOCK**

Picture	Item Name	Key Changes	Master Key Option	Page
	1100GL	25	-	448

**BOX LATCH**

Picture	Item Name	Key Changes	Master Key Option	Page
	BL-70Y	5	-	448

**NOTEBOOK LOCKS**

Picture	Item Name	Key Changes	Master Key Option	Page
	WL-N1800	10000	●	449
	WL-P1800	250	-	449
	WL-S1800	10000	●	450
	PC20K	-	-	450

# HIGH SECURITY LOCK



## NO990



- Lock & release by special key implanted magnet.
- Pin cylinder is worked by magnetic impact.
- Avoid lock-picking & duplication of the key.
- With Drill-Protection cover type available.
- Max. 40,000 key changes available.
- Key is removable in locked position only.
- [JVMA1001] standard approved by "Japan Vending Machine Manufacturers Association".

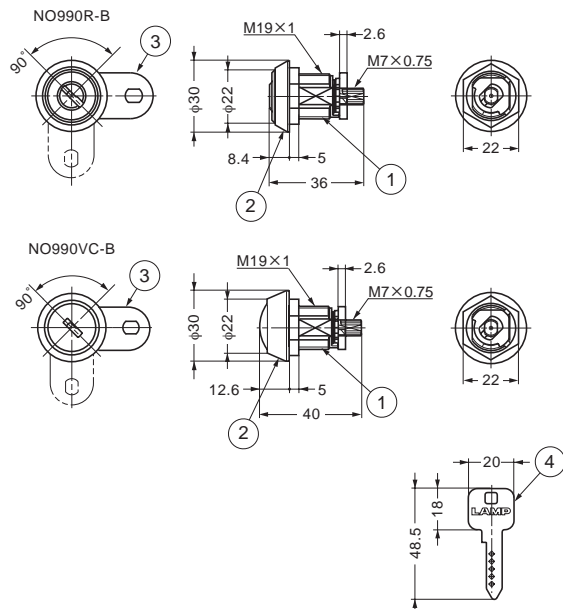

### Installation

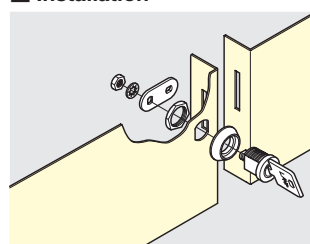

### Cut Out Dimensions

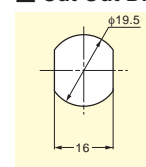

No.	Part Name	Material	Finish
①	Body	Brass	Chrome
②	Ring	NO990R-B : Brass, NO990VC-B : Zinc Alloy	Chrome
③	Cam	Steel	Clear Zinc Chromate
④	Key	Brass/Magnet	Chrome

Item Code	Item Name	Key type	Drill Protection Cover	Door Thickness	Weight	Box	Carton
150-013-020	NO990R-B	Key Different	without	0.8~8	103g	25pcs	100pcs
150-013-019	NO990VC-B	Key Different	with	0.8~8	109g	25pcs	100pcs

# SHEET METAL CAM LOCK



## DCY-34



- High security with special key design.
- Reversible key.
- 90 degree cam rotation.
- Key is removable in locked position only. (Key works as a knob in unlocked position.)
- Universal direction - Cam direction changeable.
- 2,000 key changes available.
- Master key type available at surcharge. (Maximum 866 key changes per master key)

### Installation

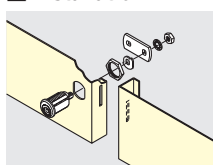

### Cut Out Dimensions

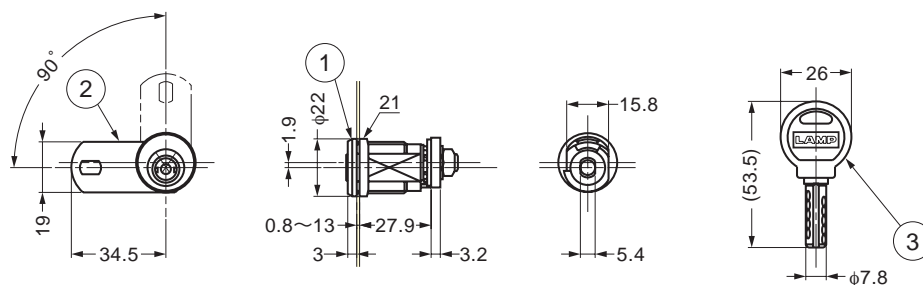
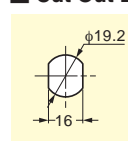

No.	Part Name	Material	Finish/Color
①	Body	Brass	Chrome
②	Cam	Copper	Yellow Zinc Chromate
③	Key	Brass/ABS	Nickel/Black

Item Code	Item Name	Key type	Door Thickness	Weight
150-014-159	DCY-34-B	Key Different	0.8~13	101g
150-014-158	DCY-34-D	Key Alike	0.8~13	101g

# SHEET METAL CAM LOCK

900



- Brass cylinder cam lock.
- Reversible key.
- 90 degree cam rotation.
- Key is removable in locked position only.  
(Key works as a knob in unlocked position.)
- 1 million key changes available.
- Master key type available at surcharge.  
(Maximum 2,520 key changes per master key.)

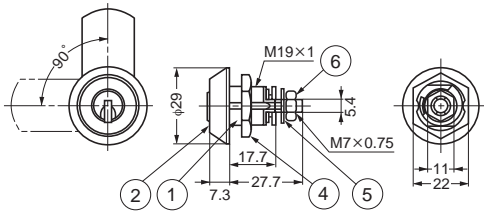

Standard type

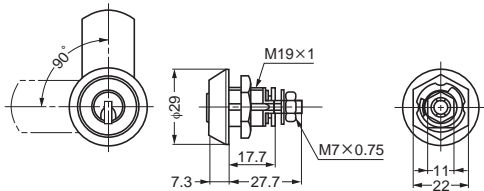

Master key type

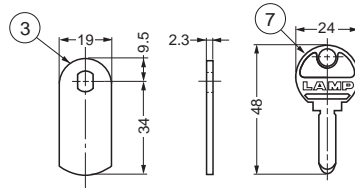

■ Cut Out Dimensions

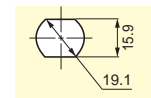

Standard type

■ Cut Out Dimensions

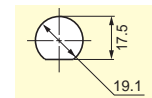

Master key type

No.	Part Name	Material	Finish
①	Body	Brass	Chrome
②	Ring	Brass	Chrome
③	Cam	Steel	Yellow Zinc Chromate
④	Hex Nut	Steel	Yellow Zinc Chromate
⑤	Washer	Steel	Nickel
⑥	Hex Nut	Steel	Yellow Zinc Chromate
⑦	Key	Brass	Nickel

■ Installation

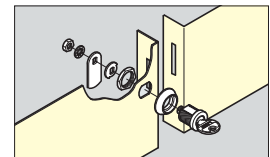

Item Code	Item Name	Key type	Weight	Box	Carton
150-060-247	900-B	Key Different	120g	12pcs	60pcs
150-001-080	900-D	Key Alike	120g	12pcs	60pcs

# SHEET METAL CAM LOCK



3800S



- High corrosion with stainless steel material in use.
- Reversible key.
- Key is removable in locked position only.  
(Key works as a knob in unlocked position.)
- Universal direction - Cam direction changeable.
- 300 key changes available.
- Master key type available at surcharge.  
(Maximum 300 key changes per master key.)

■ Cut Out Dimensions

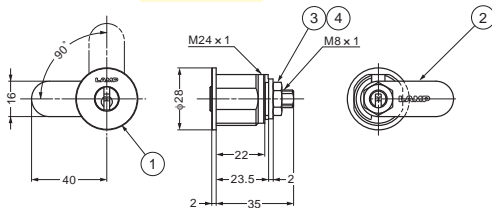
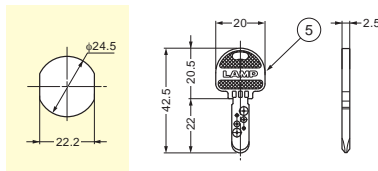

■ Installation

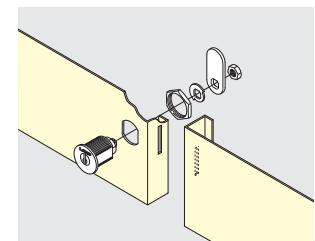

No.	Part Name	Material	Finish
①	Body	Stainless Steel (SUS303)	Satin
②	Cam	Stainless Steel (SUS304)	Satin
③	Hex Nut	Stainless Steel (SUS303)	Satin
④	Washer	Stainless Steel (SUS304)	Satin
⑤	Key	Nickel Silver	-

Item Code	Item Name	Key type	Weight	Box	Carton
150-012-921	3800S-B	Key Different	119g	12pcs	60pcs
150-012-920	3800S-D	Key Alike	119g	12pcs	60pcs

# SHEET METAL CAM LOCK CLI-31



- Clip-on installation.
- Key is removable in locked position only.
- Max. 108 key changes.

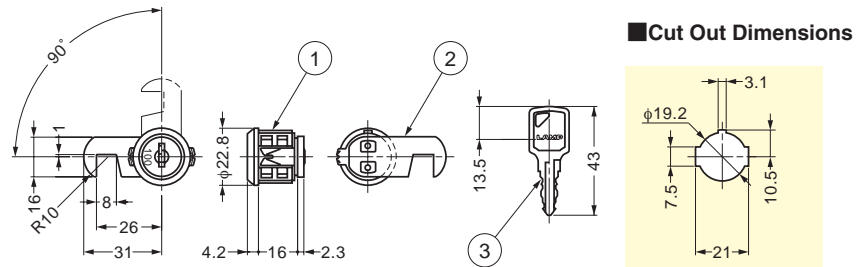

No.	Part Name	Material	Finish
①	Body	Zinc Alloy	Chrome
②	Cam	Copper	Clear Zinc Chromate
③	Key	Brass	Nickel

Item Code	Item Name	Key type	Door Thickness	Weight
150-014-155	CLI-31-B	Key Different	0.8	58g
150-014-154	CLI-31-D	Key Alike	0.8	58g

# SHEET METAL CAM LOCK SN-711-8



- Brass cylinder cam lock.
- 90 degree cam rotation.
- Key is removable in locked position only.
- 1,500 key changes available.
- \* Extreme pressure on key when in unlocked position may cause damage to the lock.

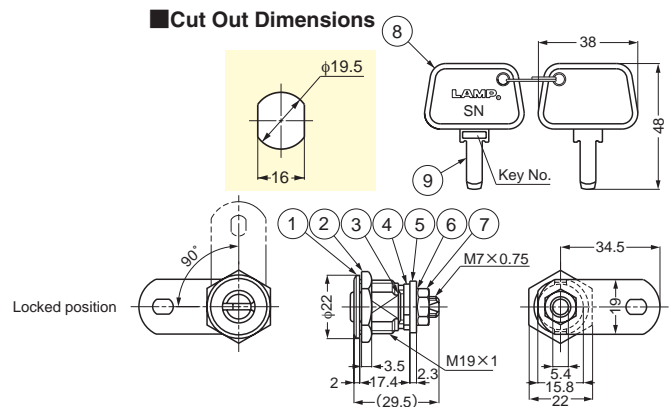

No.	Part Name	Material	Finish
①	Body	Brass	Chrome
②	Large Hex Nut	Steel	Clear Zinc Chromate
③	Ring	Stainless Steel (SUS304)	Plain
④	Cam	Steel	Clear Zinc Chromate
⑤	Plate	Steel	Clear Zinc Chromate
⑥	Washer	Steel	Clear Zinc Chromate
⑦	Small Hex Nut	Steel	Clear Zinc Chromate
⑧	Cover	ABS	Black
⑨	Key	Brass	Nickel

Item Code	Item Name	Key type	Weight
150-060-621	SN-711-8-D	Key Alike	77g



# SHEET METAL MINI CAM LOCK

# NAL-S



- Mini zinc alloy cylinder cam lock for sheet metal doors.
- 90 degrees cam rotation.
- Cam is reversible.
- NAL-S-1: Key withdrawals in locked position only. (Key works as a knob in unlocked position.)
- NAL-S-2: Key withdrawals in both locked and unlocked positions.
- Master key type available upon request. (Special order)
- \* Not suitable for compression latch situation.
- \* Pressure to cam may cause damage to cylinder.
- 100 key changes available.

No.	Part Name	Material	Finish
①	Body	Zinc Alloy	Chrome
②	Hex Nut	Steel	Clear Zinc Chromate
③	Cam	Steel	Chrome
④	Screw	Steel	Clear Zinc Chromate
⑤	Key	Steel & Brass	Chrome
⑥	Key/Ring	Stainless Steel (SUS304)	-

### ■ Cover Cap for dust-Optional

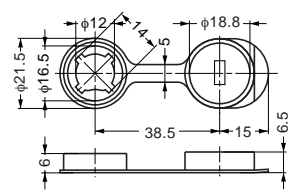

Item Code	Item Name	Material	Color	Weight	Box	Carton
150-039-050	NAL-S CAP	Polythylene	Black	1.5g	500pcs	2,000pcs

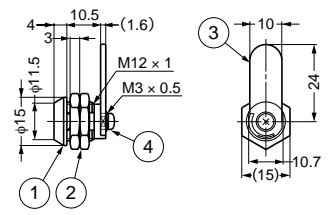

### ■ Cut Out Dimensions

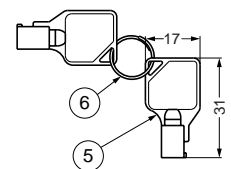
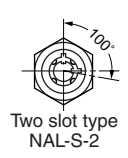
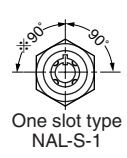
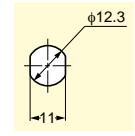

※ Turn the cam (3) over to use NAL-S as a counterclockwise turn lock.

Item Code	Item Name	Number of Slot (s)	Key type	Weight	Box	Carton
150-060-667	NAL-S-1-D	1	Key Alike	25g	100pcs	500pcs
150-060-666	NAL-S-2-D	2	Key Alike	25g	100pcs	500pcs

# SHEET METAL CAM LOCK

# NAL



- Brass cylinder tubular cam lock.
- 90 degree cam rotation.
- Key is removable in locked position only. (Key can be used as knob in un-locked position.)
- Special order for different key configuration available upon request.
- 5,000 key changes available.

### ■ Installation

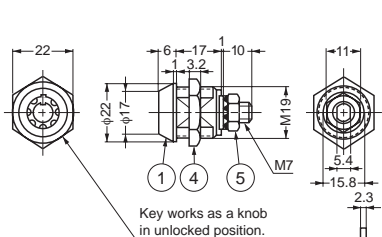
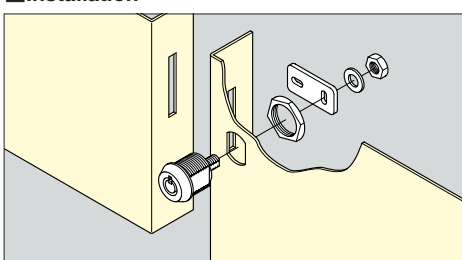

### ■ Cut Out Dimensions

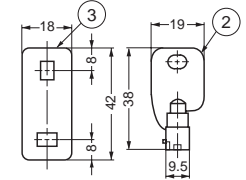
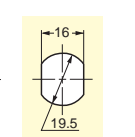

Key works as a knob in unlocked position.

No.	Part Name	Material	Finish
①	Body	Brass	Chrome
②	Key	Steel	Nickel
③	Cam	Steel	Yellow Zinc Chromate
④	Hex Nut	Zinc Alloy	Yellow Zinc Chromate
⑤	Hex Nut	Zinc Alloy	Yellow Zinc Chromate

Item Code	Item Name	Key type	Cylinder Diameter	Door Thickness	Weight	Box
150-061-067	NAL-B	Key Different	φ 19 (Width 15.8)	Max. 10	55g	100pcs
150-061-068	NAL-D	Key Alike	φ 19 (Width 15.8)	Max. 10	55g	100pcs

# PUSH LOCK

# 2100B



- Zinc alloy cylinder push lock for metal-framed glass doors or sheet metal double sliding doors.
- Push cylinder to lock.
- Cylinder Diameter: 18.6mm (47/64")
- Keys can be shared with other 2100 series locks.
- 12 key changes available.

### Installation

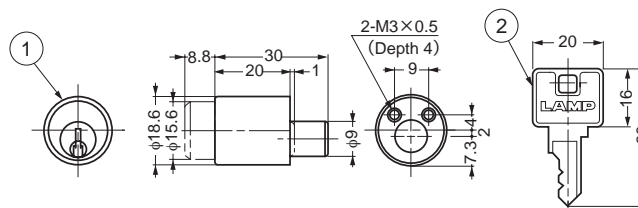
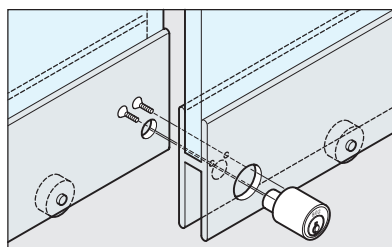

No.	Part Name	Material	Finish
①	Body	Zinc Alloy	Satin Nickel
②	Key	Brass	Nickel

Item Code	Item Name	Key type	Cylinder Diameter	Metal Frame Thickness	Weight	Box	Carton
150-001-070	2100B-B	Key Different	φ 18.6	20	50g	40pcs	400pcs
150-001-071	2100B-D	Key Alike	φ 18.6	20	50g	40pcs	400pcs

# PUSH LOCK

# 2110B



- Zinc alloy cylinder push lock for metal-framed glass doors or sheet metal double sliding doors.
- Key is required to lock and to unlock.
  - To Lock: Insert key and turn 60° clockwise. Push-in the cylinder and turn the key 60° back.
- Cylinder Diameter: 18.6mm
- Keys can be shared with other 2100 series locks.
- 12 key changes available.

### Installation

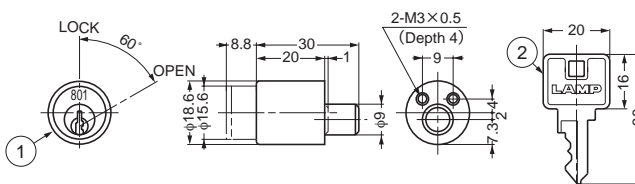
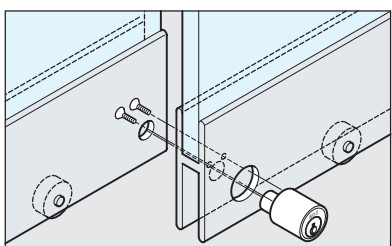

No.	Part Name	Material	Finish
①	Body	Zinc Alloy	Satin Nickel
②	Key	Brass	Nickel

Item Code	Item Name	Key type	Cylinder Diameter	Metal Frame Thickness	Weight	Box	Carton
150-001-072	2110B-B	Key Different	φ 18.6	20	50g	40pcs	400pcs
150-001-073	2110B-D	Key Alike	φ 18.6	20	50g	40pcs	400pcs

# PUSH LOCK

# 2150B



- Zinc alloy cylinder push lock for metal-framed glass door or sheet metal double sliding doors.
- Push cylinder to lock.
- Cylinder Diameter: 18.6mm
- Master key NOT available.
- 24 key changes available.

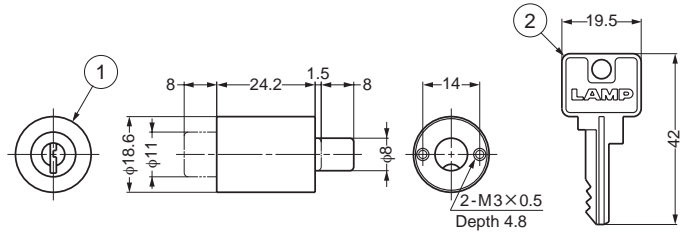

### Installation

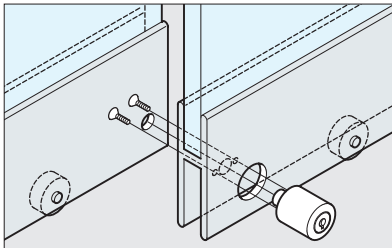

No.	Part Name	Material	Finish
①	Body	Zinc Alloy	Nickel
②	Key	Brass	Nickel

Item Code	Item Name	Key type	Cylinder Diameter	Metal Frame Thickness	Weight	Box	Carton
150-060-410	2150B-B	Key Different	φ 18.6	24	50g	24pcs	240pcs
150-060-411	2150B-D	Key Alike	φ 18.6	24	50g	24pcs	240pcs
150-060-069	2160B-B	Key Different	φ 18.6	24	50g	24pcs	240pcs
150-060-070	2160B-D	Key Alike	φ 18.6	24	50g	24pcs	240pcs

# PUSH LOCK

# 6300



- Zinc alloy cylinder push lock for metal-framed glass doors.
- Easy installation. Only 10mm hole required on door.
- Cylinder Diameter: 17.6mm
- Bolt Length: 25mm
- Bolt Diameter: 9.8mm
- 96 key changes.
- Master key NOT available.
- Sheet metal thickness is 1.2mm.

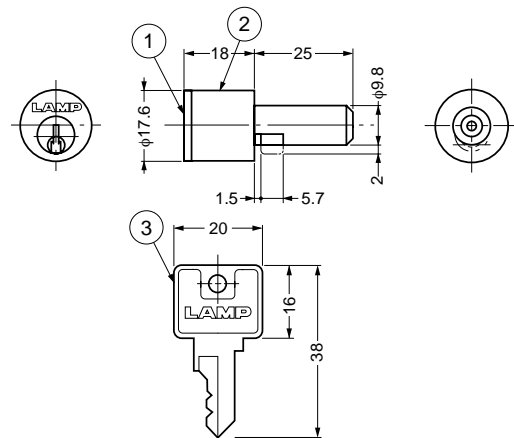

### Installation

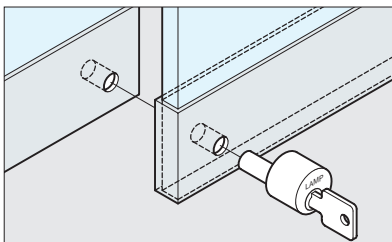

No.	Part Name	Material	Finish
①	Body	Zinc Alloy	Satin Nickel
②	Cover	Brass	Nickel
③	Key	Brass	Nickel

Item Code	Item Name	Key type	Cylinder Diameter	Metal Frame Thickness	Sheet Metal Thickness	Weight	Box	Carton
150-001-145	6300-D	Key Alike	φ 9.8	19	1.2	50g	24pcs	240pcs



# CABINET LOCK (W/INDICATOR)



2200QL



### Installation

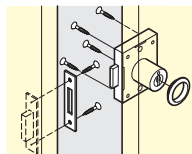
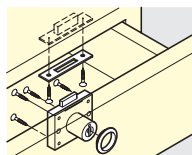

※Lock for Right side application is made to order

- Only 1/8 turn is needed to unlock/lock the door.
- Key automatically returns to original position making it easy to remove the key.
- 300 key changes comes with indicator available.
- Master key type available at surcharge. (Maximum 170 key changes per master key)
- Spacer (6810-SP) sold separately.

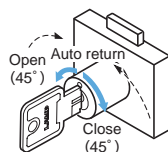
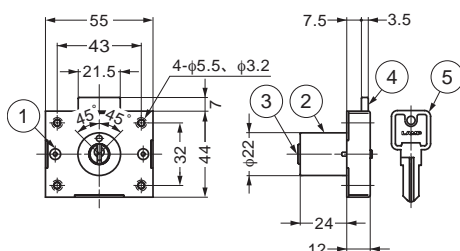

No.	Part Name	Material	Finish
①	Body	Stainless Steel (SUS304)	—
②	Cylinder (Outer)	Brass	Chrome
③	Cylinder (Inner)	Zinc Alloy	Chrome
④	Dead Bolt	Zinc Alloy	Nickel
⑤	Key	Brass	Nickel

Item Code	Item Name	Key type	Cylinder Diameter	Door Thickness	Weight	Box	Carton
150-012-927	2200QL-24-B	Key Different	φ 22	24	200g	12pcs	60pcs
150-012-926	2200QL-24-D	Key Alike	φ 22	24	200g	12pcs	60pcs

# CABINET LOCK



3810S



### Installation

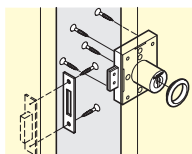
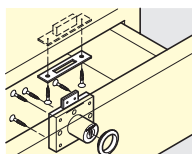

- Stainless steel body, cylinder & dead bolt.
- Turn the key 360° to lock or unlock.
- Reversible key.
- Cylinder rotates for either drawer or cabinet door application.
- 300 key changes available.
- Master key is available as made to order.
- Spacer (6810-SP) sold separately.

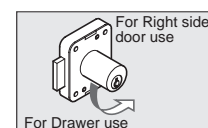
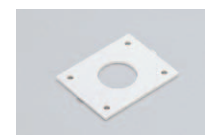
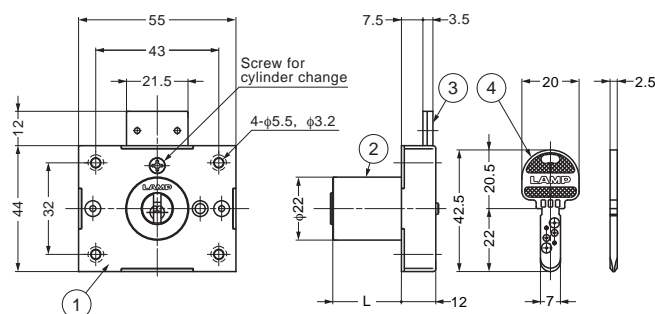

No.	Part Name	Material	Finish
①	Body	Stainless Steel (SUS304)	—
②	Cylinder	Stainless Steel (SUS303)	Satin
③	Dead Bolt	Stainless Steel (SUS304)	—
④	Key	Nickel Silver	Plain

Item Code	Item Name	Key type	Cylinder Diameter	L	Door Thickness	Weight	Box	Carton
150-012-923	3810S-24-B	Key Different	φ 22	24	24	180g	12pcs	60pcs
150-012-925	3810S-30-B	Key Different	φ 22	30	30	195g	12pcs	60pcs
150-012-922	3810S-24-D	Key Alike	φ 22	24	24	180g	12pcs	60pcs
150-012-924	3810S-30-D	Key Alike	φ 22	30	30	195g	12pcs	60pcs

# GLASS DOOR CAM LOCK

# 1100GL



- Chrome or polished brass cylinder glass door lock with 2 keys.
- Cylinder Diameter: 18mm. (45/64")
- Key works as a knob in unlocked position.
- 25 key changes.
- Master key NOT available.

### Installation

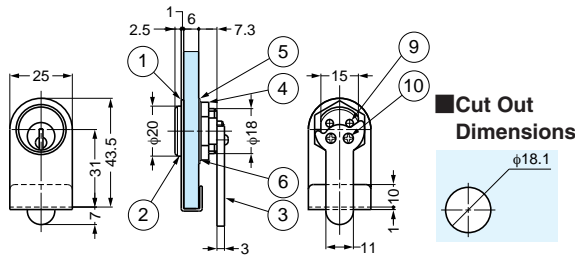
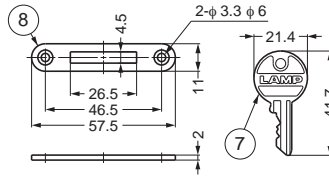
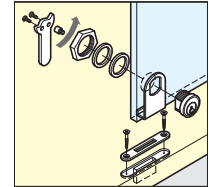

No.	Part Name	Material	Finish/Color/Specs	
			1100GLCR	1100GLM
①	Front Plate	Stainless Steel (SUS304) :CR	Polished	Polished, Clear
①	Front Plate	Brass:M	Polished	Polished, Clear
②	Body	Brass	Chrome	Polished, Clear
③	Cam	Steel	Nickel	Brass, Clear
④	Hex Nut	Brass	Nickel	Plain
⑤	Plastic Washer	Polyamide	Natural	Natural
⑥	Washer	Steel	Chrome	Chrome
⑦	Key	Brass	Nickel	Brass, Clear
⑧	Counter Plate	Steel	Chrome	Brass, Clear
⑨	Lock Pin	Brass	Plain	Plain
⑩	Screw	Steel	Clear Zinc Chromate	Screw M2.6×6

Item Code	Item Name	Key type	Cylinder Diameter	Glass Thickness	Finish	Weight	Box	Carton
150-069-510	1100GLCR-B	Key Different	φ 18	4~6	Chrome	65g	25pcs	250pcs
150-001-060	1100GLCR-D	Key Alike	φ 18	4~6	Chrome	65g	25pcs	250pcs
150-061-276	1100GLM-B	Key Different	φ 18	4~6	Polished	65g	25pcs	250pcs
150-001-062	1100GLM-D	Key Alike	φ 18	4~6	Polished	65g	25pcs	250pcs

# BOX LATCH (W/LOCK)



# BL-70Y



- Latch ideal for box and case.
- Automatically latches when lid closed.
- Push button to release.
- 2 keys included.
- 5 key changes available on request.

### Installation

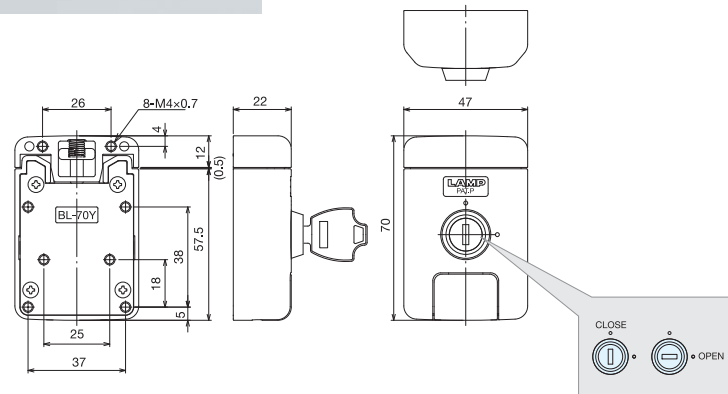
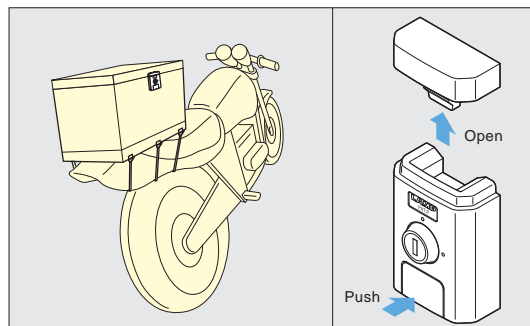

Item Code	Item Name	Weight (g)	Box (pcs)
150-001-076	BL-70Y	220	10

Part Name	Material	Finish/Color
Body, Strike	Zinc Alloy	Silver
Push Button	POM	Grey

# NOTEBOOK LOCK



# NOTEBOOK LOCK

# WL-N1800



- Suitable for security of notebook.
- Wire length 1,800mm.
- Wire dia.  $\Phi$ 5mm.
- 10,000 key changes.
- Master key available as made to order. (Max. 200 key changes per master key)
- Key is removable in locked position only.

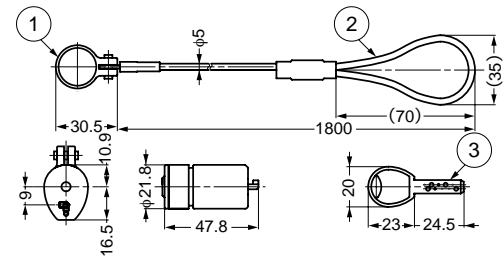
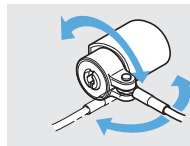
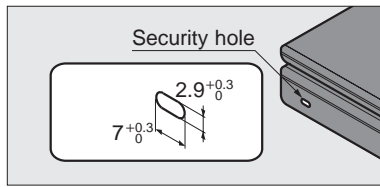
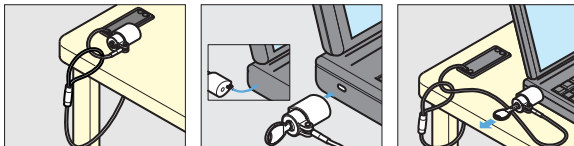

No.	Part Name	Material	Finish
①	Lock Body	Zinc Alloy	Satin Nickel
②	Wire	Steel	PVC Coating
③	Key	Brass	Nickel

Item Code	Item Name	Key type	Weight	Box	Carton
150-001-081	WL-N1800-B	Key Different	194.2g	10pcs	100pcs

# NOTEBOOK LOCK

# WL-P1800



- Suitable for security of notebook.
- Slim design for thin type notebook.
- Wire length 1,800mm.
- Wire dia.  $\Phi$ 4mm.
- 250 key changes.
- Key is removable in locked position only.

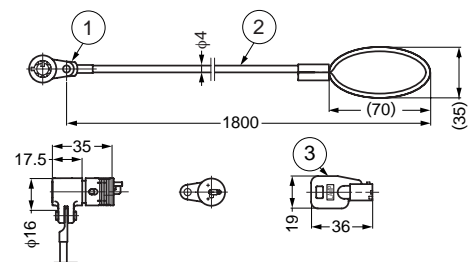
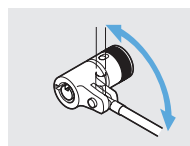
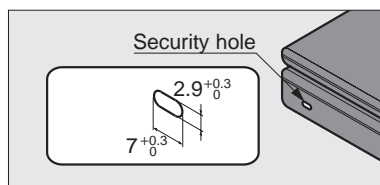
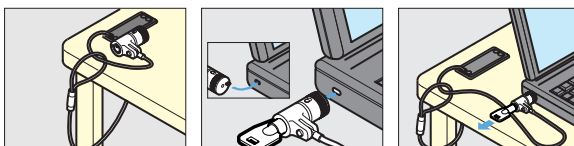

No.	Part Name	Material	Finish
①	Lock Body	Zinc Alloy	Satin Nickel
②	Wire	Steel	PVC Coating
③	Key	Brass	Nickel

Item Code	Item Name	Key type	Weight	Box	Carton
150-060-063	WL-P1800-B	Key Different	134g	10pcs	100pcs

# NOTEBOOK LOCK

# WL-S1800



- Suitable for security of notebook.
- Wire length 1,800mm.
- Wire dia.  $\Phi$ 3.5mm.
- 10,000 key changes.
- Master key available. (Max. 250 key changes per master key)
- Key is removable in locked position only.

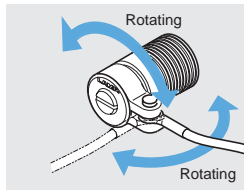
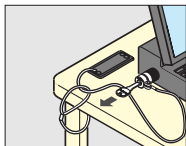
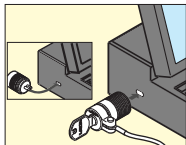
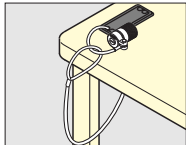
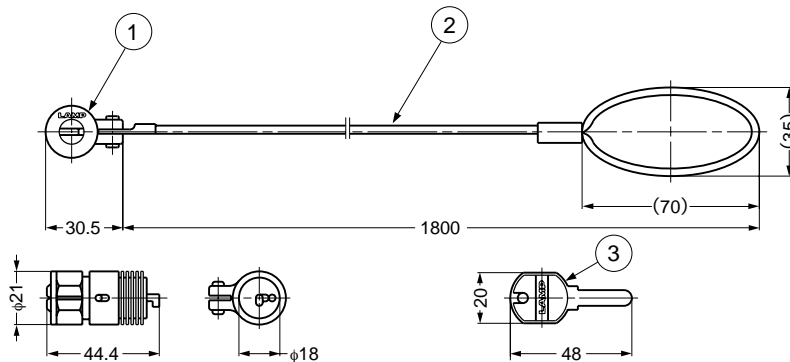

No.	Part Name	Material	Finish
①	Lock Body	Zinc Alloy	Satin Nickel
②	Wire	Steel	PVC Coating
③	Key	Brass	Nickel

### Master Key (Sold Separately)

Item Code	Item Name
150-001-082	WL-S1800MK1

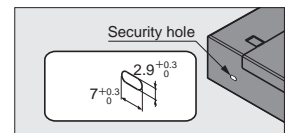

Item Code	Item Name	Key type	Master Key	Weight	Box	Carton
150-001-127	WL-S1800-B	Key Different	with	165g	5pcs	50pcs
150-060-675	WL-S1800-D	Key Alike	without	165g	5pcs	50pcs

# ADAPTOR (FOR WL-S1800)

# PC20K



- For connecting WL-S1800 to RS-232C.

### Installation

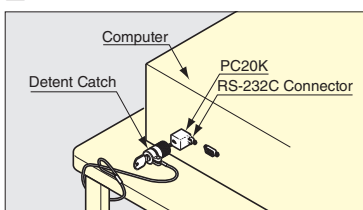

### Installation

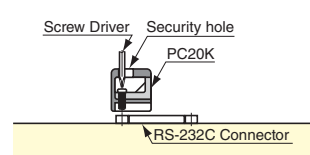

### RS-232C Connector port

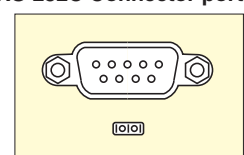

Item Code	Item Name	Material	Finish	Box	Carton
150-060-008	PC20K	Zinc Alloy	Nickel	40pcs	400pcs

## MISCELLANEOUS



## MISCELLANEOUS

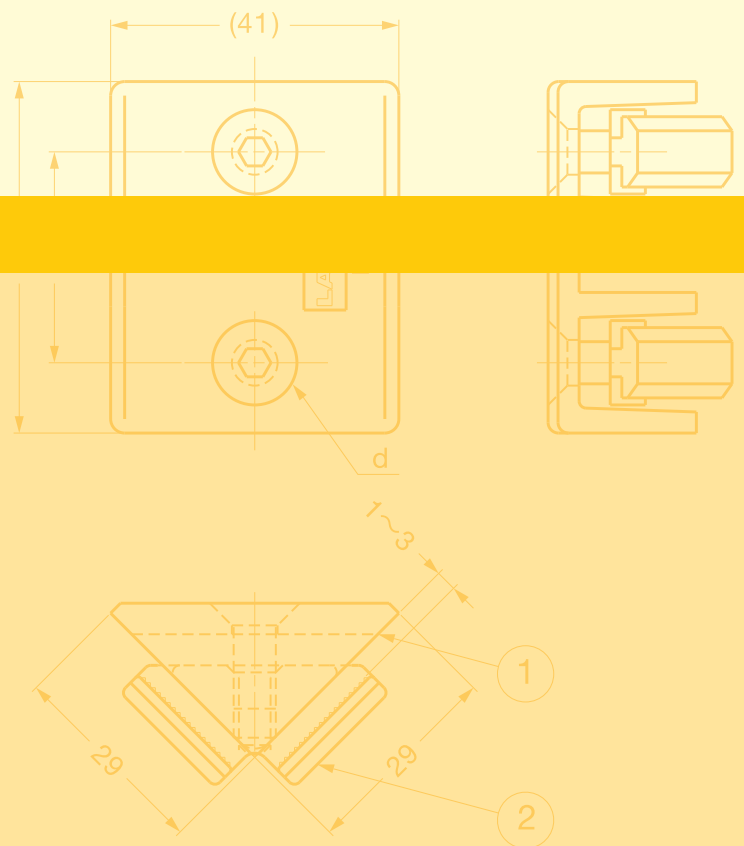

CABLE GROMMETS

Picture	Item Name	Page
	APD-KH	453
	LN72S	453
	S445, S51, S60, S76, S89	454
	LS	454
	ST	455
	V60, V80	455
	8001, 8002	456
	S93-35	456
	ALU	456
	S165-76	457
	SI2520	457
	V2000	457
	S1015-51	457
	ART973	458
	S100-50	458
	8000N	458
	CL-24	458

VENTILATORS

Picture	Item Name	Page
	AST	459
	ASM	459
	SA-M	459
	SA-D	460
	ASD	460
	AST-160, 210	460
	1-1212	461
	1-2222	461
	1-1122	461
	1-2211	462

SWIVEL

Picture	Item Name	Page
	HF	462

LED LIGHTS

Picture	Item Name	Page
	SL-WPG	463 ~ 464
	SL-T	465

BELT REEL PARTITION

Picture	Item Name	Page
	AP-BR06	466

# VENTILATOR



# APD-KH

• Ventilator and Cable Grommet Combination.



■ APD-KH66

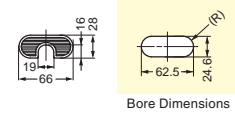

■ APD-KH170

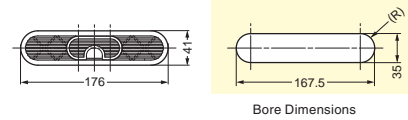

■ APD-KH260

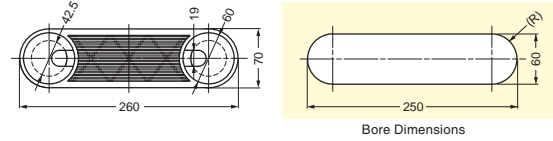

※APD-KH260: Ivory, Black, and Brown only.



Chromate(CR)

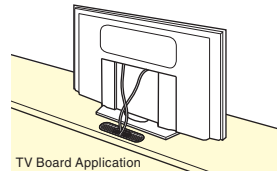

Black(BL)



Brown(BR)



Ivory(IV)



White(WT)

Item Code	Item Name	Color	Material	Air Flow Volume	Weight	Box	Carton
210-020-910	APD-KH66-CR	Chrome	ABS	610 mm <sup>3</sup>	4g	100pcs	500pcs
210-020-912	APD-KH66-IV	Ivory	ABS	610 mm <sup>3</sup>	4g	100pcs	500pcs
210-020-914	APD-KH66-BL	Black	ABS	610 mm <sup>3</sup>	4g	100pcs	500pcs
210-020-911	APD-KH66-BR	Brown	ABS	610 mm <sup>3</sup>	4g	100pcs	500pcs
210-020-913	APD-KH66-WT	White	ABS	610 mm <sup>3</sup>	4g	100pcs	500pcs
210-020-564	APD-KH170-CR	Chrome	ABS	1690 mm <sup>3</sup>	17g	40pcs	320pcs
210-020-566	APD-KH170-IV	Ivory	ABS	1690 mm <sup>3</sup>	17g	40pcs	320pcs
210-020-568	APD-KH170-BL	Black	ABS	1690 mm <sup>3</sup>	17g	40pcs	320pcs
210-020-565	APD-KH170-BR	Brown	ABS	1690 mm <sup>3</sup>	17g	40pcs	320pcs
210-020-567	APD-KH170-WT	White	ABS	1690 mm <sup>3</sup>	17g	40pcs	320pcs
210-020-570	APD-KH260-IV	Ivory	ABS	3150 mm <sup>3</sup>	57g	10pcs	80pcs
210-020-571	APD-KH260-BL	Black	ABS	3150 mm <sup>3</sup>	57g	10pcs	80pcs
210-020-569	APD-KH260-BR	Brown	ABS	3150 mm <sup>3</sup>	57g	10pcs	80pcs

# CABLE GROMMET



# LN72S

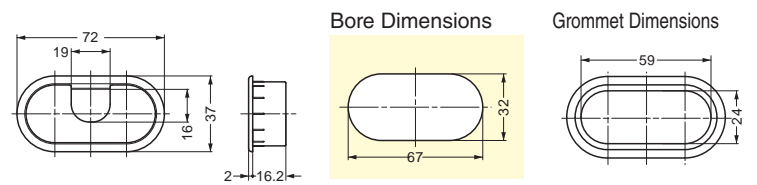

Item Code	Item Name	Color	Material	Weight	Box	Carton
210-021-706	LN72S-WT	White	ABS	8g	40pcs	320pcs
210-021-707	LN72S-BL	Black	ABS	8g	40pcs	320pcs



# CABLE GROMMET

# S445, S51, S60, S76, S89

454

Miscellaneous

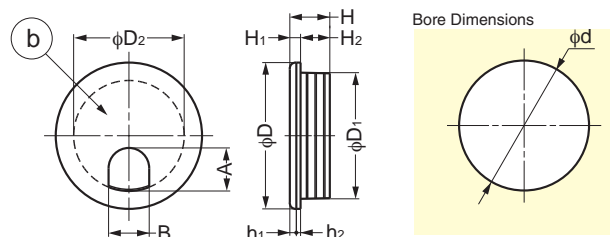

Item Code	Item Name	Color	Material	D	D <sub>1</sub>	D <sub>2</sub>	H	H <sub>1</sub>	H <sub>2</sub>	h <sub>1</sub>	h <sub>2</sub>	A	B	d	Weight	Box	Carton
210-031-830	S445CM	Creme	ABS	45	38.8	34	19.7	3.3	16.4	2	1.3	16.7	12.5	39	9g	50pcs	450pcs
210-031-831	S445W	White	ABS	45	38.8	34	19.7	3.3	16.4	2	1.3	16.7	12.5	39	9g	50pcs	450pcs
210-031-829	S445G	Grey	ABS	45	38.8	34	19.7	3.3	16.4	2	1.3	16.7	12.5	39	9g	50pcs	450pcs
210-031-828	S445B	Black	ABS	45	38.8	34	19.7	3.3	16.4	2	1.3	16.7	12.5	39	9g	50pcs	450pcs
210-031-834	S51CM	Creme	ABS	51	44.8	39.7	19.9	3.6	16.3	2	1.6	19	15.5	45	11g	30pcs	300pcs
210-031-835	S51W	White	ABS	51	44.8	39.7	19.9	3.6	16.3	2	1.6	19	15.5	45	11g	30pcs	300pcs
210-031-833	S51G	Grey	ABS	51	44.8	39.7	19.9	3.6	16.3	2	1.6	19	15.5	45	11g	30pcs	300pcs
210-031-832	S51B	Black	ABS	51	44.8	39.7	19.9	3.6	16.3	2	1.6	19	15.5	45	11g	30pcs	300pcs
210-031-838	S60CM	Creme	ABS	60.5	48.8	44	19.8	3.6	16.2	2	1.6	20.8	19	49	14g	25pcs	250pcs
210-031-839	S60W	White	ABS	60.5	48.8	44	19.8	3.6	16.2	2	1.6	20.8	19	49	14g	25pcs	250pcs
210-031-837	S60G	Grey	ABS	60.5	48.8	44	19.8	3.6	16.2	2	1.6	20.8	19	49	14g	25pcs	250pcs
210-031-836	S60B	Black	ABS	60.5	48.8	44	19.8	3.6	16.2	2	1.6	20.8	19	49	14g	25pcs	250pcs
210-031-814	S76CM	Creme	ABS	76.5	64.8	59	20.3	4.2	16.1	2.6	1.6	21.5	21.5	65	22g	15pcs	150pcs
210-031-815	S76W	White	ABS	76.5	64.8	59	20.3	4.2	16.1	2.6	1.6	21.5	21.5	65	22g	15pcs	150pcs
210-031-813	S76G	Grey	ABS	76.5	64.8	59	20.3	4.2	16.1	2.6	1.6	21.5	21.5	65	22g	15pcs	150pcs
210-031-812	S76B	Black	ABS	76.5	64.8	59	20.3	4.2	16.1	2.6	1.6	21.5	21.5	65	22g	15pcs	150pcs
210-031-818	S89CM	Creme	ABS	89.4	76.8	71.4	20.6	4.1	16.5	2.6	1.5	25	22	77	30g	10pcs	90pcs
210-031-819	S89W	White	ABS	89.4	76.8	71.4	20.6	4.1	16.5	2.6	1.5	25	22	77	30g	10pcs	90pcs
210-031-817	S89G	Grey	ABS	89.4	76.8	71.4	20.6	4.1	16.5	2.6	1.5	25	22	77	30g	10pcs	90pcs
210-031-816	S89B	Black	ABS	89.4	76.8	71.4	20.6	4.1	16.5	2.6	1.5	25	22	77	30g	10pcs	90pcs

# CABLE GROMMET

# SL

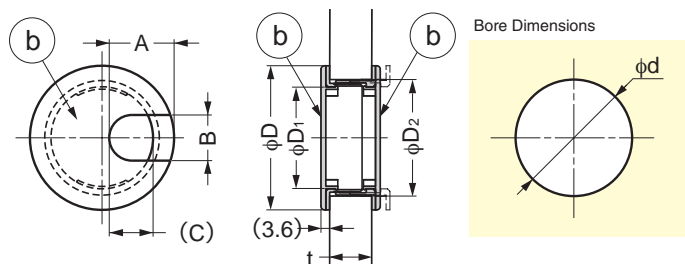

Item Code	Item Name	Color	Material	D	D <sub>1</sub>	D <sub>2</sub>	A	B	C	t	d	Weight	Box	Carton
210-035-071	SL60WT	White	ABS	60	42.5	48.5	27	19	18	18~24	48.5	20g	20pcs	300pcs
210-035-070	SL60BL	Black	ABS	60	42.5	48.5	27	19	18	18~24	48.5	20g	20pcs	300pcs
210-031-304	SL76WT	White	ABS	76	58.2	64.2	34	22	25.1	25~40	64.2	25g	12pcs	96pcs
210-031-305	SL76BL	Black	ABS	76	58.2	64.2	34	22	25.1	25~40	64.2	25g	12pcs	96pcs



# CABLE GROMMET



ST

• Cover rotate 90°.

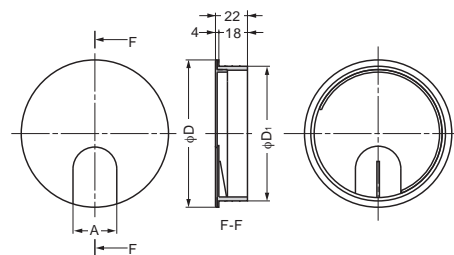

Bore Dimensions

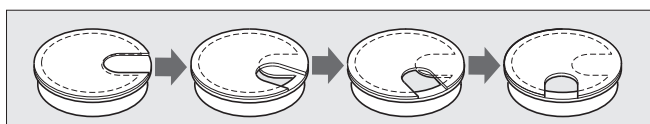
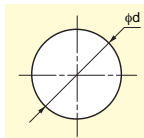

Item Code	Item Name	Color	Material	A	D	D1	d	Weight	Box	Carton
210-031-802	ST70W	White	ABS	22	70	60	60	13.7g	15pcs	150pcs
210-031-803	ST70CM	Ivory	ABS	22	70	60	60	13.7g	15pcs	150pcs
210-031-804	ST70SL	Silver	ABS	22	70	60	60	13.7g	15pcs	150pcs
210-031-805	ST70G	Grey	ABS	22	70	60	60	13.7g	15pcs	150pcs
210-031-806	ST70B	Black	ABS	22	70	60	60	13.7g	15pcs	150pcs
210-031-807	ST88W	White	ABS	26	88	80	80	13.2g	10pcs	80pcs
210-031-808	ST88CM	Ivory	ABS	26	88	80	80	13.2g	10pcs	80pcs
210-031-809	ST88SL	Silver	ABS	26	88	80	80	13.2g	10pcs	80pcs
210-031-810	ST88G	Grey	ABS	26	88	80	80	13.2g	10pcs	80pcs
210-031-811	ST88B	Black	ABS	26	88	80	80	13.2g	10pcs	80pcs

# CABLE GROMMET

V60, V80

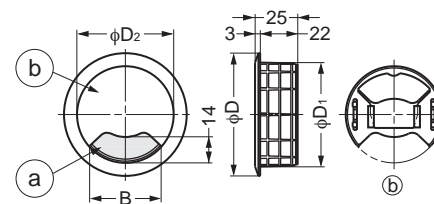

Bore Dimensions

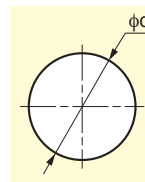

Item Code	Item Name	Color	Material	D	D1	D2	B	d	Weight	Box	Carton
210-031-857	V60W	White	High impact polystyrene	72	61	56.7	41	60.5	25.5g	15pcs	150pcs
210-031-859	V60BE	Beige	High impact polystyrene	72	61	56.7	41	60.5	25.5g	15pcs	150pcs
210-031-858	V60DBE	Dark Beige	High impact polystyrene	72	61	56.7	41	60.5	25.5g	15pcs	150pcs
210-031-866	V60SL	Silver	High impact polystyrene	72	61	56.7	41	60.5	25.5g	15pcs	150pcs
210-031-865	V60RG	Light Brown	High impact polystyrene	72	61	56.7	41	60.5	25.5g	15pcs	150pcs
210-031-856	V60B	Black	High impact polystyrene	72	61	56.7	41	60.5	25.5g	15pcs	150pcs
210-031-853	V80W	White	High impact polystyrene	92	80.5	77	50	80	39g	10pcs	80pcs
210-031-855	V80BE	Beige	High impact polystyrene	92	80.5	77	50	80	39g	10pcs	80pcs
210-031-854	V80DBE	Dark Beige	High impact polystyrene	92	80.5	77	50	80	39g	10pcs	80pcs
210-031-867	V80SL	Silver	High impact polystyrene	92	80.5	77	50	80	39g	10pcs	80pcs
210-031-864	V80RG	Light Brown	High impact polystyrene	92	80.5	77	50	80	39g	10pcs	80pcs
210-031-852	V80B	Black	High impact polystyrene	92	80.5	77	50	80	39g	10pcs	80pcs

# CABLE GROMMET

8001,8002



Bore Dimensions

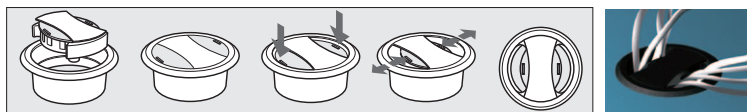
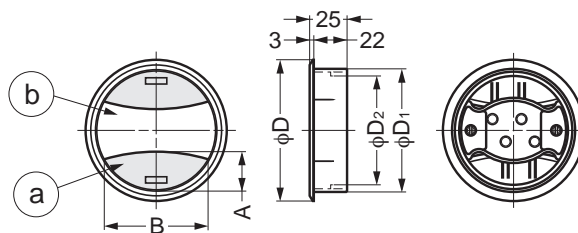
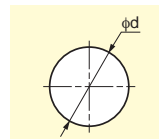

Item Code	Item Name	Color	Material	D	D1	D2	A	B	d	Weight	Box	Carton
210-031-843	8001W	White	ABS	71	60	51.5	18.5	50	60	31g	15pcs	150pcs
210-031-842	8001G	Grey	ABS	71	60	51.5	18.5	50	60	31g	15pcs	150pcs
210-031-846	8001SL	Silver	ABS	71	60	51.5	18.5	50	60	31g	15pcs	150pcs
210-031-845	8001BR	Brown	ABS	71	60	51.5	18.5	50	60	31g	15pcs	150pcs
210-031-844	8001B	Black	ABS	71	60	51.5	18.5	50	60	31g	15pcs	150pcs
210-031-848	8002W	White	ABS	91	80	71.5	24	67	80	47g	10pcs	80pcs
210-031-847	8002G	Grey	ABS	91	80	71.5	24	67	80	47g	10pcs	80pcs
210-031-851	8002SL	Silver	ABS	91	80	71.5	24	67	80	47g	10pcs	80pcs
210-031-850	8002BR	Brown	ABS	91	80	71.5	24	67	80	47g	10pcs	80pcs
210-031-849	8002B	Black	ABS	91	80	71.5	24	67	80	47g	10pcs	80pcs

# CABLE GROMMET

S93-35



Application

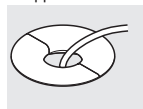

Bore Dimensions

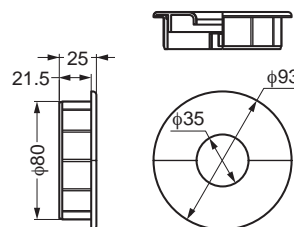
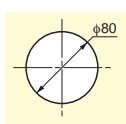

Item Code	Item Name	Material	Color	Weight	Box
210-030-314	S93-35SL	ABS	Silver	35g	132pcs
210-030-315	S93-35CG	ABS (Strike) Zinc Alloy (Cover)	Chrome	139g	132pcs

# CABLE GROMMET

ALU25-20



Bore Dimensions

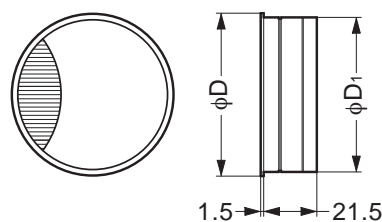
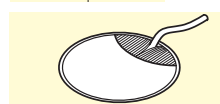
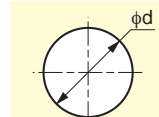

Item Code	Item Name	D	D1	d	Material	Color	Weight	Box
210-030-162	ALU25-20-325	66	60	60	Aluminum Alloy, Polyamide	Anodized, Black	45g	250pcs
210-030-163	ALU25-20-330	86	80	80	Aluminum Alloy, Polyamide	Anodized, Black	80g	250pcs

# CABLE GROMMET



S165-76

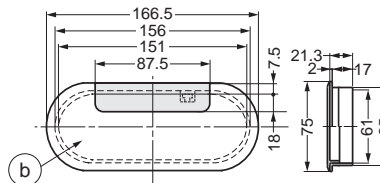

Bore Dimensions

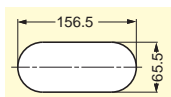

Item Code	Item Name	Color	Material	Weight	Box	Carton
210-031-827	S165-76CM	Ivory	ABS	50g	5pcs	50pcs
210-031-826	S165-76W	White	ABS	50g	5pcs	50pcs
210-031-825	S165-76G	Grey	ABS	50g	5pcs	50pcs
210-031-824	S-165-76B	Black	ABS	50g	5pcs	50pcs

# CABLE GROMMET

SI2520

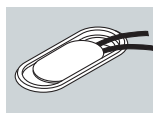

Bore Dimensions

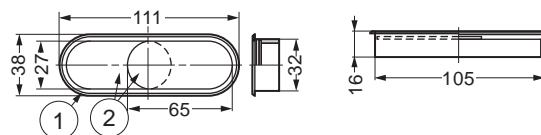
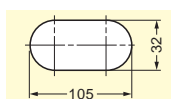

No.	Part Name	Material	Finish/Color
①	Body	Polyethylene	Black
②	Cover	Stainless Steel	Satin

Item Code	Item Name	Weight	Box	Carton
210-031-473	SI2520	35g	20pcs	200pcs

# CABLE GROMMET



V2000

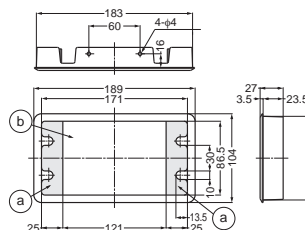

Bore Dimensions

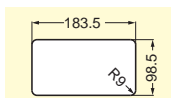

- With or without screw holes type available.
- With or without screw holes type available.

Item Code	Item Name	Color	Material	Weight	Box	Carton
210-031-861	V2000W	White	High impact polystyrene	104g	1pcs	10pcs
210-031-863	V2000BE	Beige	ABS	104g	1pcs	10pcs
210-031-862	V2000DBE	Dark Beige	ABS	104g	1pcs	10pcs
210-031-860	V2000B	Black	ABS	104g	1pcs	10pcs

# CABLE GROMMET



S1015-51

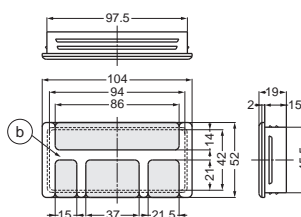
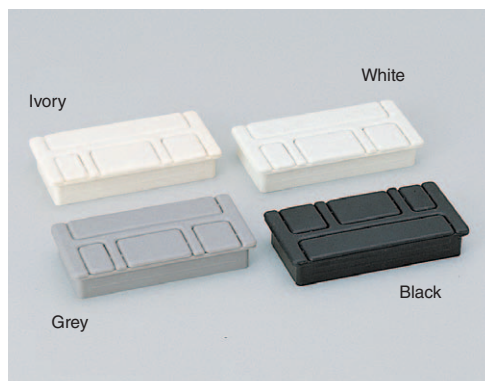

Bore Dimensions

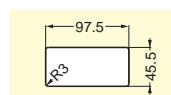

Item Code	Item Name	Color	Material	Weight	Box	Carton
210-031-822	S1015-51CM	Ivory	ABS	22g	15pcs	150pcs
210-031-823	S1015-51W	White	ABS	22g	15pcs	150pcs
210-031-821	S1015-51G	Grey	ABS	22g	15pcs	150pcs
210-031-820	S1015-51B	Black	ABS	22g	15pcs	150pcs

# CABLE GROMMET



## ART973

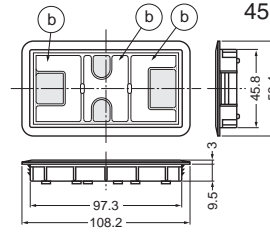
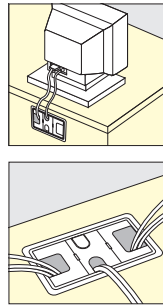

- Cut out dimensions for metal sheat : 97.8 x 46.5mm ( sheat thickness 0.8 - 1mm ).
- Cut out dimensions for wood : 97.5 x 45.8mm.

Item Code	Item Name	Color	Material	Weight	Box
210-035-132	ART973	White	ABS	20g	140pcs

# CABLE GROMMET



## S100-50

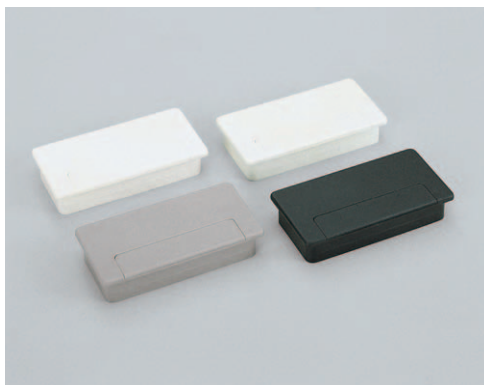

Bore Dimensions

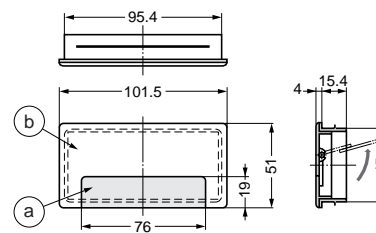
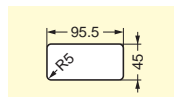

Item Code	Item Name	Color	Material	Weight	Box	Carton
210-031-800	S100-50W	White	ABS	24g	15pcs	150pcs
210-031-801	S100-50BE	Beige	ABS	24g	15pcs	150pcs
210-031-840	S100-50DBE	Dark Beige	ABS	24g	15pcs	150pcs
210-031-841	S100-50BL	Black	ABS	24g	15pcs	150pcs

# CABLE GROMMET

## 8000N

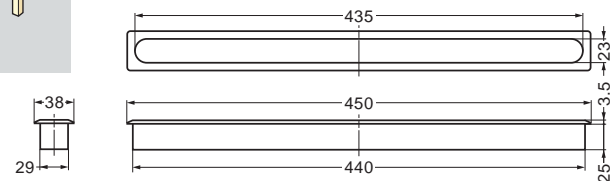
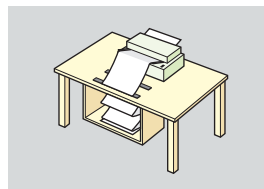
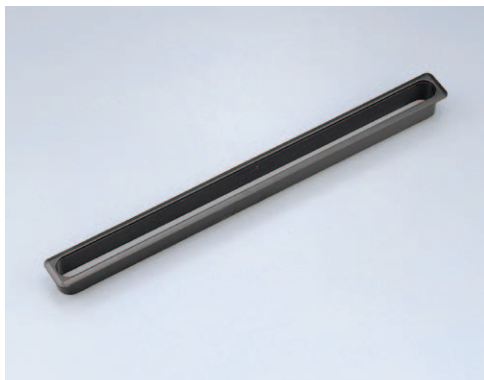

Item Code	Item Name	Color	Material	Weight	Box
210-030-894	8000N	Black	ABS	80g	25pcs

# CABLE GROMMET

## CL-24

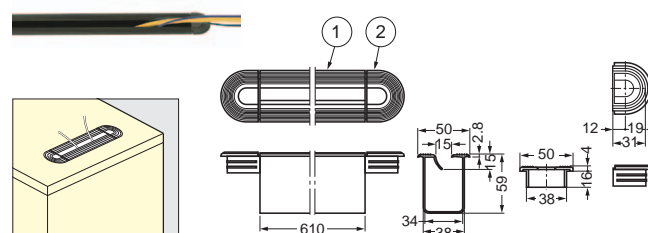

Item Code	Item Name	Length	Weight
210-035-267	CL-24	610	343g

No.	Part Name	Material	Color
①	Body	Chloroethylene	Black
②	End Cap	Chloroethylene	Black

# VENTILATOR



# AST

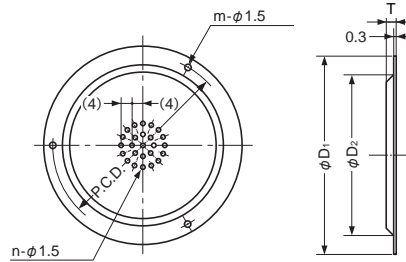

- 1.5 mm (1/16") diameter holes.
- Supplied with Stainless Steel nail. (1.2x10)

Installation

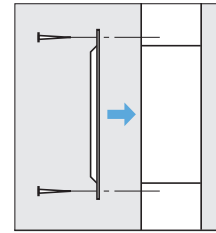

Material	Finish
Stainless Steel(SUS304)	Satin

Item Code	Item Name	D <sub>1</sub>	D <sub>2</sub>	T	P.C.D.	m	n	Max.Exhaust Area	Weight	Box	Carton
210-030-044	AST-45	45	34	3	40	3	37	≈65mm <sup>2</sup>	4g	100pcs	3,600pcs
210-030-045	AST-55	55	44	3	50	3	59	≈104mm <sup>2</sup>	5g	100pcs	3,600pcs
210-030-046	AST-70	70	55	3	64	3	127	≈224mm <sup>2</sup>	9g	100pcs	2,400pcs
210-030-047	AST-100	100	81	4	91	4	271	≈478mm <sup>2</sup>	19g	50pcs	500pcs

# VENTILATOR



# ASM

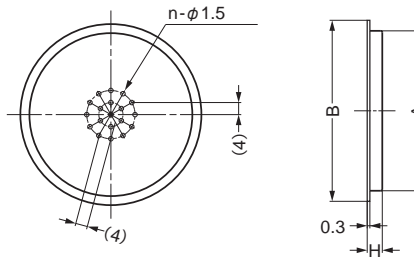

- 1.5 mm (1/16") diameter holes.

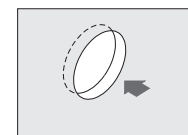

Installation

Material	Finish
Stainless Steel(SUS304)	Satin

Item Code	Item Name	A	B	H	n	Max.Exhaust Area	Weight	Box	Carton
210-030-010	ASM-37	31	36	4.5	37	≈65mm <sup>2</sup>	3g	100pcs	3,600pcs
210-030-011	ASM-45	41	46	4.5	59	≈104mm <sup>2</sup>	5g	100pcs	3,600pcs
210-030-012	ASM-60	53	60	5	127	≈224mm <sup>2</sup>	8g	100pcs	2,400pcs
210-030-013	ASM-85	77	85	5	271	≈478mm <sup>2</sup>	13.5g	50pcs	1,000pcs

# VENTILATOR



# SA-M

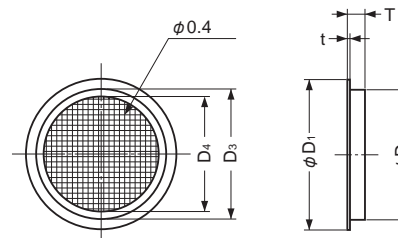

- 0.4mm mesh wire diameter.

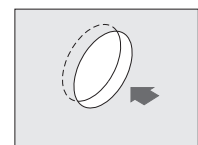

Installation

Material	Finish
Stainless Steel(SUS304)	Satin

Item Code	Item Name	D <sub>1</sub>	D <sub>2</sub>	D <sub>3</sub>	D <sub>4</sub>	T	t	Max.Exhaust Area	Weight	Box	Carton
210-030-164	SA-M37	36	31.5	30	25	5.7	0.3	≈290mm <sup>2</sup>	4.5g	70pcs	1,400pcs
210-030-165	SA-M45	46	41.5	40	35	5.2	0.3	≈570mm <sup>2</sup>	6g	60pcs	1,200pcs
210-030-166	SA-M60	60	53.5	52	46	6.0	0.3	≈1000mm <sup>2</sup>	9.5g	50pcs	1,000pcs
210-030-167	SA-M85	85	77.8	76.5	68	6.2	0.3	≈2150mm <sup>2</sup>	16.5g	30pcs	600pcs
210-030-168	SA-M120	120	110.5	108	99	7.2	0.5	≈4480mm <sup>2</sup>	46.5g	20pcs	200pcs

# VENTILATOR



## SA-D

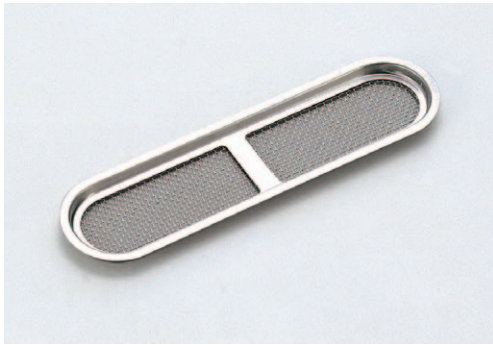

• 0.4mm mesh wire diameter.

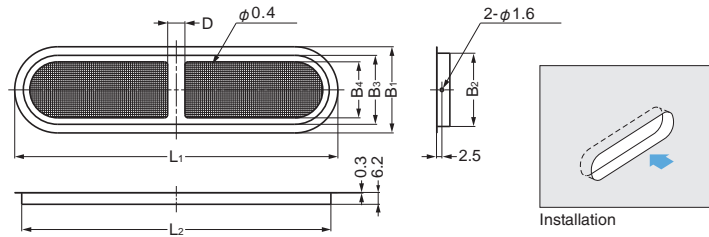

Material	Finish
Stainless Steel(SUS304)	Satin

Item Code	Item Name	L <sub>1</sub>	L <sub>2</sub>	B <sub>1</sub>	B <sub>3</sub>	B <sub>4</sub>	B <sub>2</sub>	D	Max.Exhaust Area	Weight	Box	Carton
210-030-169	SA-D150	150	143.5	40	32	26	34	8	≅ 1880mm <sup>2</sup>	18.5g	30pcs	600pcs
210-030-170	SA-D200	200.5	194	50	42	35	44	10	≅ 3800mm <sup>2</sup>	30g	30pcs	300pcs

# VENTILATOR



## ASD



• 1.5 mm (1/16") diameter holes.

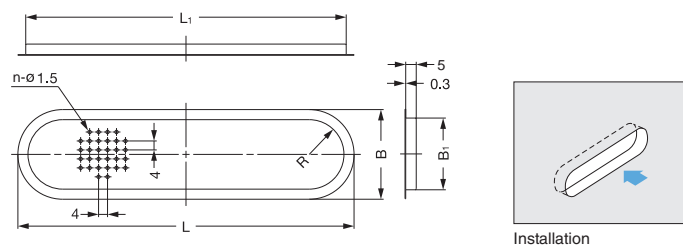

Material	Finish
304 Stainless Steel	Satin

Item Code	Item Name	L	L <sub>1</sub>	B	B <sub>1</sub>	R	n	Max.Exhaust Area	Weight	Box	Carton
210-030-018	ASD-150	150	143	40	33	16	268	≅ 470mm <sup>2</sup>	14.5g	80pcs	1920pcs
210-030-019	ASD-200	200	193	50	42.8	21	450	≅ 790mm <sup>2</sup>	23g	40pcs	960pcs

# VENTILATOR



## AST-160, 210

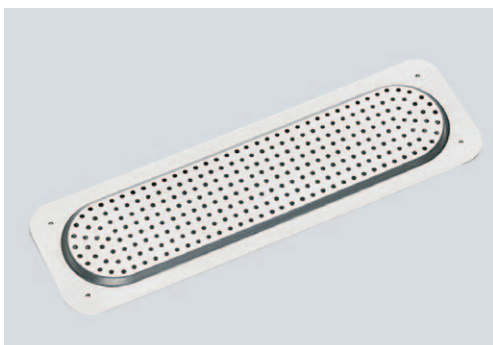

• 1.5 mm (1/16") diameter holes.  
• Supplied with Stainless Steel nail. (1.2x10)

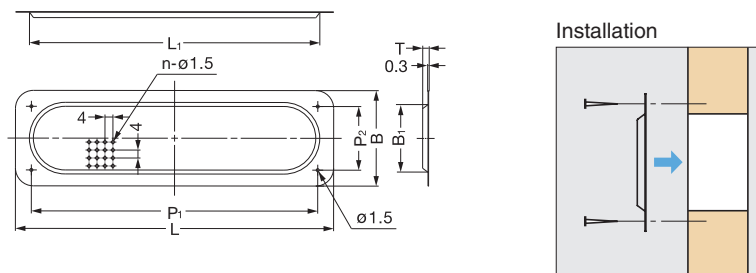

Material	Finish
304 Stainless Steel	Satin

Item Code	Item Name	L	L <sub>1</sub>	B	B <sub>1</sub>	P <sub>1</sub>	P <sub>2</sub>	T	n	Max.Exhaust Area	Weight	Box	Carton
210-030-052	AST-160	160	146	48	36	144	32	3	268	≅ 470mm <sup>2</sup>	18g	50pcs	1000pcs
210-030-053	AST-210	210	196	58	46	194	42	4	450	≅ 790mm <sup>2</sup>	28g	50pcs	1200pcs

**VENTILATOR**   **1-1212**

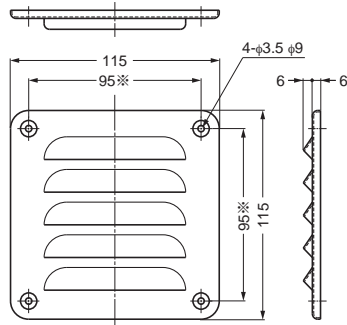

Item Code	Item Name	Material	Finish	Max Exhaust Area	Weight	Box
210-172-012	1-1212	Stainless Steel(SUS316)	Satin	1900mm <sup>2</sup>	89g	10pcs

**VENTILATOR**   **1-2222**

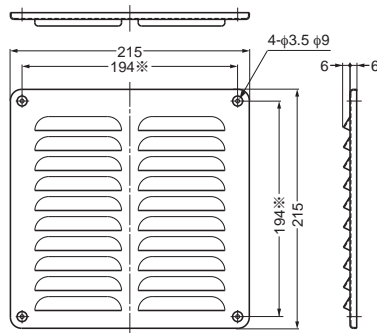

Item Code	Item Name	Material	Finish	Max Exhaust Area	Weight	Box
210-172-014	1-2222	Stainless Steel(SUS316)	Satin	7500mm <sup>2</sup>	308g	10pcs

**VENTILATOR**   **1-1122**

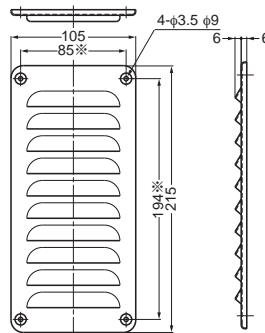

Item Code	Item Name	Material	Finish	Max Exhaust Area	Weight	Box
210-172-011	1-1122	Stainless Steel(SUS316)	Satin	3700mm <sup>2</sup>	156g	10pcs

# VENTILATOR



1-2211

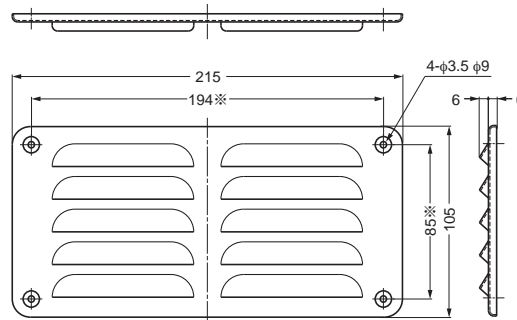

Item Code	Item Name	Material	Finish	Max.Exhaust Area	Weight	Box
210-172-013	1-2211	Stainless Steel(SUS316)	Satin	3700mm <sup>2</sup>	154g	10pcs

# SWIVEL

HF

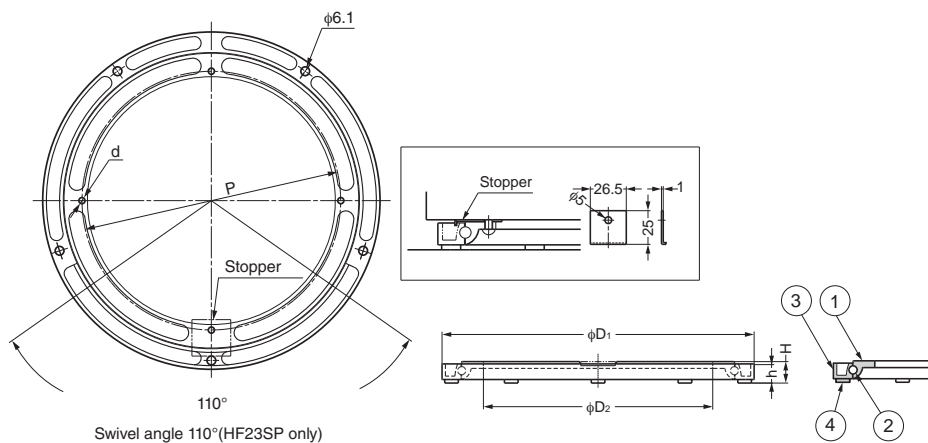
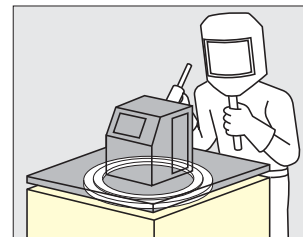
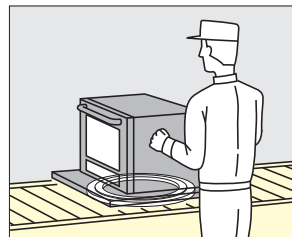

No.	Part Name	Material	Finish/Color
①	Plate	Aluminum Alloy	See Below
②	Ball	Steel	—
③	Base Plate	Aluminum Alloy	See Below
④	Leg	Synthetic Rubber	White

Item Code	Item Name	Stopper	Finish/Color	D <sub>1</sub>	D <sub>2</sub>	P	H	h	d	Holes	Load Capacity	Weight	Box
210-035-222	HF23SP	With	Barrel Polishing	230	166	176	16	15	φ 4.8	4pcs	392N / 40kgf	370g	40pcs
210-035-220	HF30	Without	Barrel Polishing	325	265	273.5	16	15	φ 4.8	6pcs	588N / 60kgf	550g	20pcs
210-035-221	HF45	Without	Barrel Polishing	442	380	392	22	16.5	φ 4.8, φ 10	6pcs	980N / 100kgf	1600g	10pcs
210-035-226	HF60	Without	Baking Finish	600	520	538	24	18.5	φ 4.8, φ 12	4pcs	1960N / 200kgf	3200g	5pcs



# LED Tough Light

# SL-WPG

**Discontinued**



- 3000 lx @ 1 meter lumens.
- Low Energy Consumption.
- 50,000 Hours.
- 24 volts.
- Soft Cool White illumination.
- Conical and Oval projected light beam.
- IP67F Rated.
- Water, Oil, Dust Resistant.
- Slim and Compact.
- Corrosion Resistant.
- Tempered Glass.
- Easy to Install.
- Heat Dissipating.

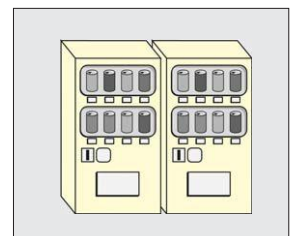
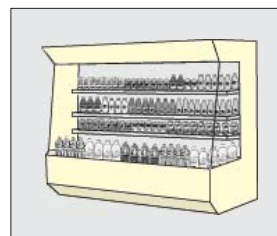
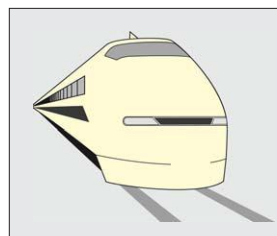
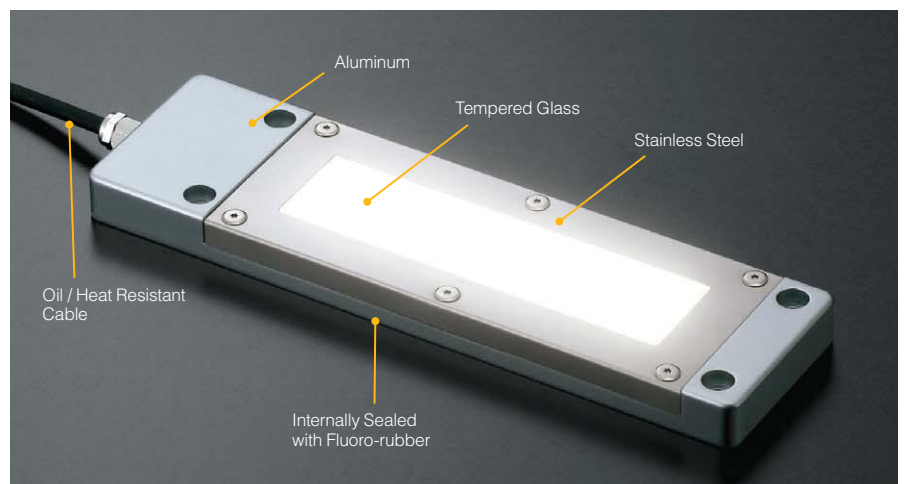

### ■ Dimensions (All 3Types)

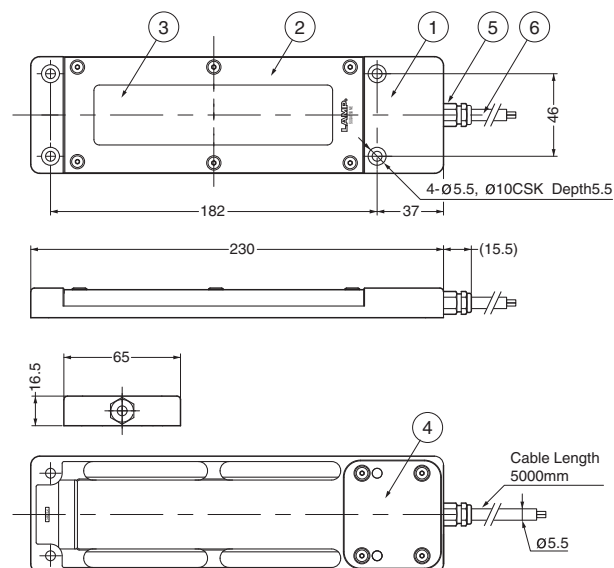

No.	Part Name	Material	Finish
①	Body	Aluminum	Urethane Coating
②	Body Cover	Stainless Steel	Plain
③	Cover Glass	Tempered Glass	Clear
④	Back Cover	Stainless Steel	Plain
⑤	Nut	Brass	Nickel
⑥	Cable	Oil / heat resistant vinyl	Matte Finish

### ■ Illuminating Area

#### Light distribution character

[SL-WPG 1]

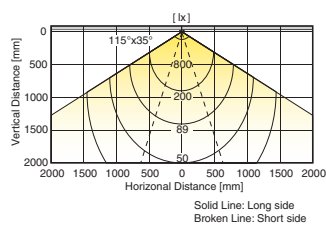

#### Horizontal illuminance (At 1m distance)

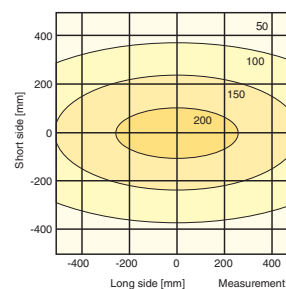

[SL-WPG 2]

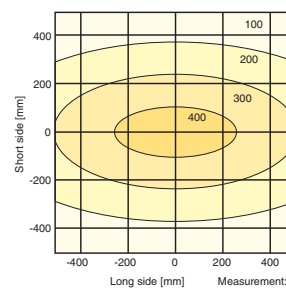
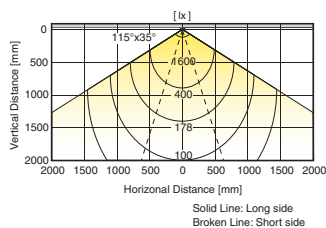

[SL-WPG 3T]

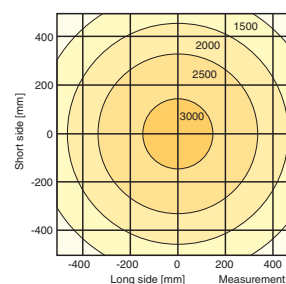
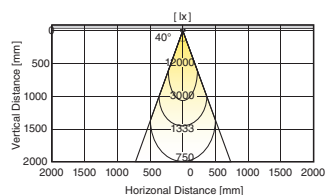

### ■ Installation Information (All 3Types)

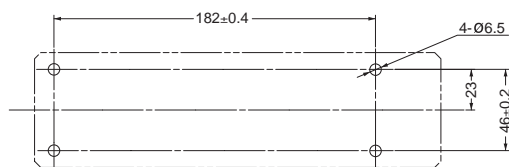

- Always install on metal surface. Install with bolts / nuts.
- Allow min. 10m spacing around the body for heat release.
- Sealing rubber may be damaged and reduce protection quality depending on the type of cutting oil or environment.

**Do not use under environments where aluminum may corrode:**  
Place where product is not in contact with mortar, concrete, and/or electrolyte fluids/objects.

### ■ Specifications

Item Code	220-016-403	220-016-404	220-016-405
Item Name	SL-WPG1-24WNSL-S	SL-WPG2-24WNSL-S	SL-WPG3-24WNSL-S
Rated Voltage	DC24V (Polar, White: + Black: -)		
Working Voltage Range	DC23~25V		
Power Consumption	6.7W	13.4W	12.0W
Light Color	Cool White		
Color Temperature	5000K		
Beam Angle	Long Side : 115° Short Side: 35°		40°
Illuminance (at 1m)	200 lx	400 lx	3000 lx
Protection Rating	IP67F (JIS C 0920:2003)		
Vibration Resistance	1. Applicable Standard: JIS C 60068-2-6 Sinusoidal vibration test 2. Vibration Direction: X, Y, Z direction 3. Frequency Range: 10 ~ 55 Hz 4. Amplitude: 50m/s <sup>2</sup> 5. Duration: 90 min. each		
Insulation Resistance	1MΩ over (DC500V )		
Light Life	50,000 hours (70% of initial light volume)		
Operating Temperature Range	-30~+60°C		
Operating Humidity Range	0 ~ 95%RH (No condensation)		
Storage Temperature Range	-30~+60°C		
Storage Humidity Range	0 ~ 95%RH (No condensation)		
Cable Length	5000mm		
Product Weight	390g	410g	380g

# LED SLIM LIGHT

# SL-T

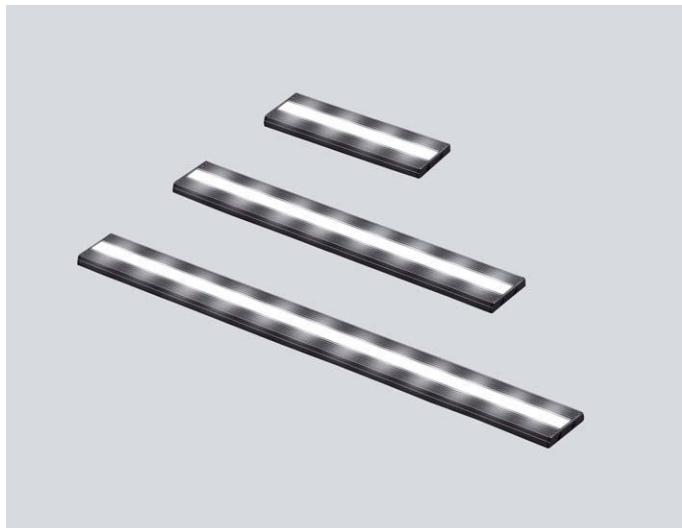

- Compact and ultra slim LED lighting unit. (Thickness 8.8mm)
  - Brightness 80 ~ 270 lm/W.
  - Low energy consumption.
  - Long life time 60,000 hours.
  - Low heat generation, no ultraviolet radiation.
  - Operating Temperature: -20~40°C (-4~104F)
  - Surface mount type. Cover will hide screw head for clean appearance.
  - Cover with screw access hole for easy installation available as special order.
  - IP66 compatible.
  - Slim design is ideal for compact and hard to reach places where extra brightness is needed.
  - Can be directly connected to input voltage.
  - Black housing available as special order.
  - Limited stock available.
- Please contact your vendor.

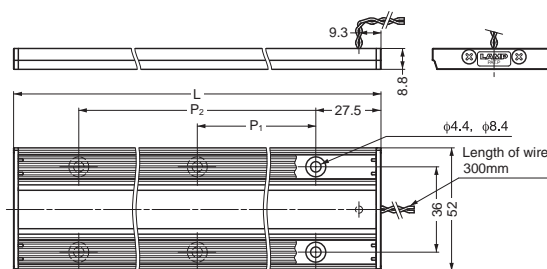
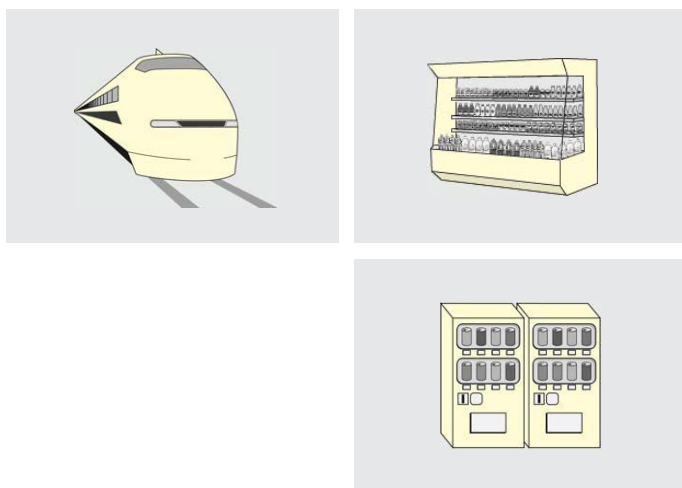

Cover with screw hidden

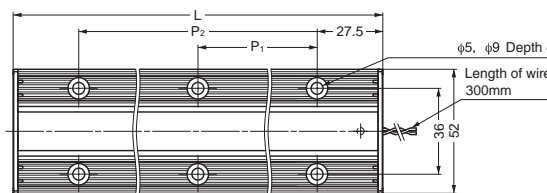

Cover with screw visible

Item Code	Item Name	Voltage	Wattage	Illuminance	Color Temperature (K)	LED Color	Cover	Material	Finish	L	P <sub>1</sub>	P <sub>2</sub>	Weight
220-500-212	SL-T-24-155-WN-BL	DC 24V	3.6W	90 lx (d=0.5m)	5000K	Neutral	Cover with screw hidden	Aluminum	Black Alumite	155	100	—	125g
220-500-229	SL-T-24-155-WL-SL	DC 24V	3.6W	80 lx (d=0.5m)	2900K	Incandescent	Cover with screw hidden	Aluminum	Silver Alumite	155	100	—	125g
220-500-213	SL-T-24-155-WL-BL	DC 24V	3.6W	80 lx (d=0.5m)	2900K	Incandescent	Cover with screw hidden	Aluminum	Black Alumite	155	100	—	125g
220-500-230	SL-T-24-310-WN-SL	DC 24V	7.2W	180 lx (d=0.5m)	5000K	Neutral	Cover with screw hidden	Aluminum	Silver Alumite	310	255	—	240g
220-500-214	SL-T-24-310-WN-BL	DC 24V	7.2W	180 lx (d=0.5m)	5000K	Neutral	Cover with screw hidden	Aluminum	Black Alumite	310	255	—	240g
220-500-231	SL-T-24-310-WL-SL	DC 24V	7.2W	160 lx (d=0.5m)	2900K	Incandescent	Cover with screw hidden	Aluminum	Silver Alumite	310	255	—	240g
220-500-215	SL-T-24-310-WL-BL	DC 24V	7.2W	160 lx (d=0.5m)	2900K	Incandescent	Cover with screw hidden	Aluminum	Black Alumite	310	255	—	240g
220-500-216	SL-T-24-465-WN-BL	DC 24V	10.8W	270 lx (d=0.5m)	5000K	Neutral	Cover with screw hidden	Aluminum	Black Alumite	465	205	410	355g
220-500-233	SL-T-24-465-WL-SL	DC 24V	10.8W	240 lx (d=0.5m)	2900K	Incandescent	Cover with screw hidden	Aluminum	Silver Alumite	465	205	410	355g
220-500-217	SL-T-24-465-WL-BL	DC 24V	10.8W	240 lx (d=0.5m)	2900K	Incandescent	Cover with screw hidden	Aluminum	Black Alumite	465	205	410	355g
220-500-234	SL-T-24-155-WN-BL-A	DC 24V	3.6W	90 lx (d=0.5m)	5000K	Neutral	Cover with screw visible	Aluminum	Black Alumite	155	100	—	125g
220-500-249	SL-T-24-155-WL-SL-A	DC 24V	3.6W	80 lx (d=0.5m)	2900K	Incandescent	Cover with screw visible	Aluminum	Silver Alumite	155	100	—	125g
220-500-250	SL-T-24-310-WN-SL-A	DC 24V	7.2W	180 lx (d=0.5m)	5000K	Neutral	Cover with screw visible	Aluminum	Silver Alumite	310	255	—	240g
220-500-236	SL-T-24-310-WN-BL-A	DC 24V	7.2W	180 lx (d=0.5m)	5000K	Neutral	Cover with screw visible	Aluminum	Black Alumite	310	255	—	240g
220-500-251	SL-T-24-310-WL-SL-A	DC 24V	7.2W	160 lx (d=0.5m)	2900K	Incandescent	Cover with screw visible	Aluminum	Silver Alumite	310	255	—	240g
220-500-237	SL-T-24-310-WL-BL-A	DC 24V	7.2W	160 lx (d=0.5m)	2900K	Incandescent	Cover with screw visible	Aluminum	Black Alumite	310	255	—	240g
220-500-252	SL-T-24-465-WN-SL-A	DC 24V	10.8W	270 lx (d=0.5m)	5000K	Neutral	Cover with screw visible	Aluminum	Silver Alumite	465	205	410	355g
220-500-238	SL-T-24-465-WN-BL-A	DC 24V	10.8W	270 lx (d=0.5m)	5000K	Neutral	Cover with screw visible	Aluminum	Black Alumite	465	205	410	355g
220-500-253	SL-T-24-465-WL-SL-A	DC 24V	10.8W	240 lx (d=0.5m)	2900K	Incandescent	Cover with screw visible	Aluminum	Silver Alumite	465	205	410	355g
220-500-239	SL-T-24-465-WL-BL-A	DC 24V	10.8W	240 lx (d=0.5m)	2900K	Incandescent	Cover with screw visible	Aluminum	Black Alumite	465	205	410	355g

# BELT REEL PARTITION

STAINLESS  
304  
STEEL

## AP-BR06

- Can be recessed inside of the wall.
- The strike plate is supplied separately.

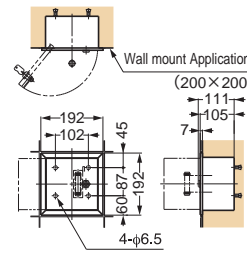

AP-BR063 (Belt length 3.5m)

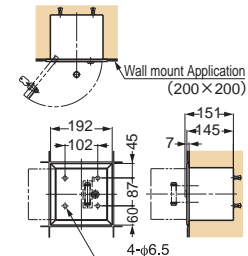

AP-BR065 (Belt length 5m)

### ■ Belt Reel Partition

Item Code	Item Name	Material	Finish	Belt Color	Size	Belt Length
290-885-007	AP-BR063(SH)	Stainless Steel(SUS304)	Satin	Red	W192 x D7(105) x H192	3.5m
290-885-008	AP-BR065(SH)	Stainless Steel(SUS304)	Satin	Red	W192 x D7(145) x H192	5m



### ■ Hook Catch(Optional)

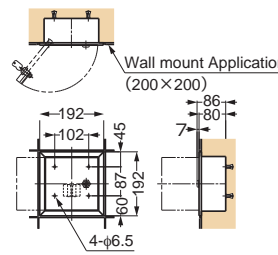

AP-BR060 (Mortise Mount)

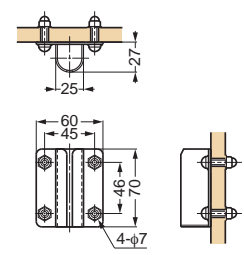

AP-BR061 (Surface Mount)

Item Code	Item Name	Spec.	Material	Finish	Size
290-885-009	AP-BR060(SH)	Mortise Mount	Stainless Steel(SUS304)	Satin	W192 x D7(80) x H192
290-885-010	AP-BR061(SH)	Surface Mount	Stainless Steel(SUS304)	Satin	W60 x D27x H70

# BELT REEL PARTITION



Aluminum type



Stacking · Rotating Head type



Surface Mount Long type(Belt length 7m)

## TEST METHODS

■ About Test Methods

Various values about products with Test **TEST** logo, such as the load capacity, hanging load capacity, catch force and retaining force, are determined by the tests performed by our company as described below. Values are to provide guidance for the safe use of our products. Product without Test **TEST** logo may not be based on these criteria in some cases.

### TEST LOAD CAPACITY TEST (TEST 1)

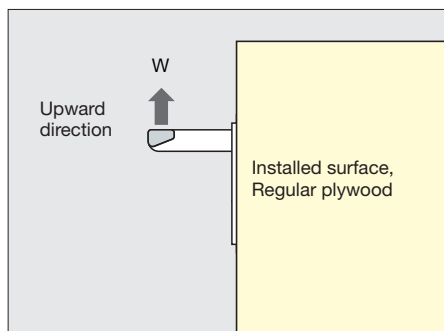

The load capacity is measured when the force (W) is gently applied in the direction of the arrow under the condition indicated by the figure.

### TEST LOAD CAPACITY TEST (TEST 2)

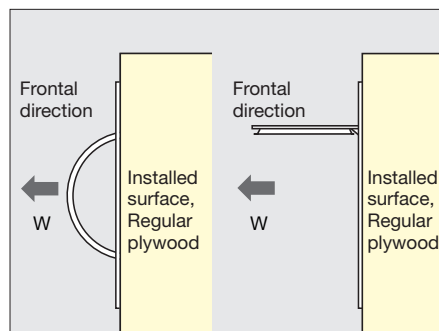

The load capacity is measured when the force (W) is gently applied in the direction of the arrow under the condition indicated by the figure. Product may fail or distort if the force is applied in a direction

other than the frontal direction. Please do not use on application other than in the pull direction.

### TEST HANGING-LOAD CAPACITY TEST (TEST 3)

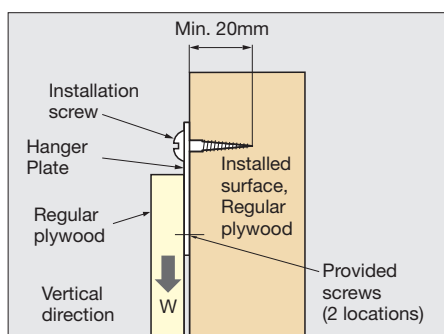

The hanging-load capacity is measured when the force (W) is gently applied in the direction of the arrow under the condition indicated by the figure. This value will vary according to the

diameter / length of the screw(s) used and strength of the installed surface.

Hanging load of 10kg (22 lbs), in case of using round-head wood screw 3.8 x 25.

### TEST HANGING-LOAD CAPACITY TEST (TEST 4)

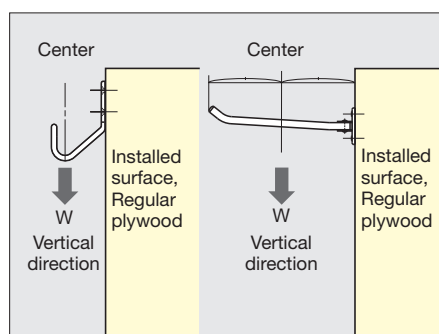

The hanging-load capacity is measured when the force (W) is gently applied at the center of the product in the direction of the arrow under the condition indicated by the figure.

### TEST MAXIMUM HANGING-LOAD TEST (TEST 5)

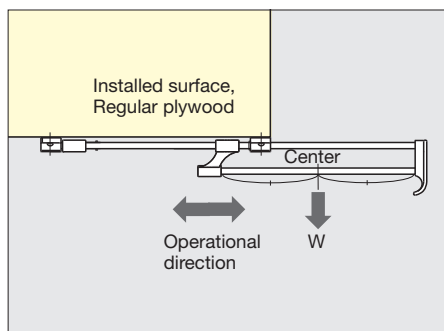

The maximum hanging-load capacity is measured when the force (W) is gently applied in the direction of the arrow and operated under the condition indicated by the figure.

If the load is concentrated at the front tip of the hanger, the front tip may sag or the movement may become heavy.

### TEST LOAD CAPACITY TEST (TEST 6)

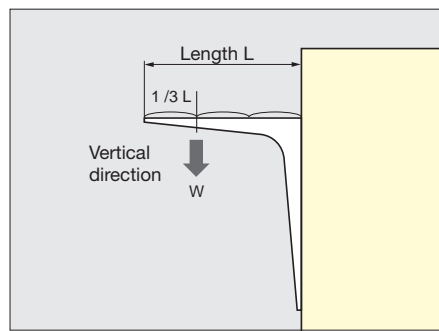

The load capacity is measured when the force (W) is gently applied in the direction of the arrow under the condition indicated by the figure. (This is based on the force (W) applied at the center

of the shelf board with its length 4/3 times longer than the shelf bracket or angle bracket.)

TEST METHODS

**TEST** LOAD CAPACITY TEST (TEST 7)

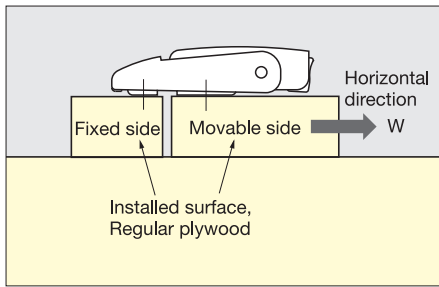

The load capacity is measured when the force (W) is gently applied in the direction of the arrow under the condition indicated by the figure.

**TEST** CLAMPING FORCE TEST UNDER STANDARD INSTALLATION (TEST 8)

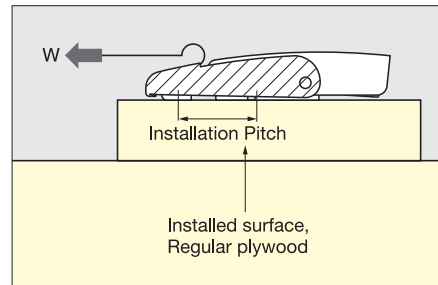

The capacity of the clamping force under standard installation is measured when the force (W) is gently applied in the direction of the arrow under the condition indicated by the figure, and when the shaded portion begins to slide.

**TEST** LOAD CAPACITY TEST (TEST 9)

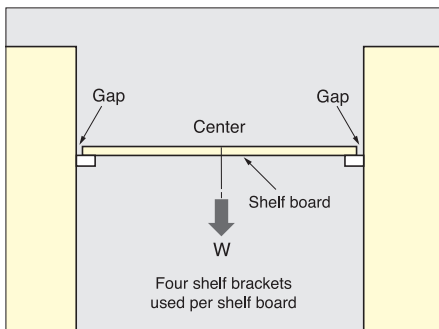

The load capacity is measured when the force (W) is gently applied in the direction of the arrow under the condition indicated by the figure.

Follow the conditions below to prevent the shelf bracket or shelf board from falling off.

- 1: The total gap between the shelf board and side board shall be 1mm or less.
- 2: Use shelf board which has sufficient durability.

**TEST** CATCH FORCE TEST (TEST 10)

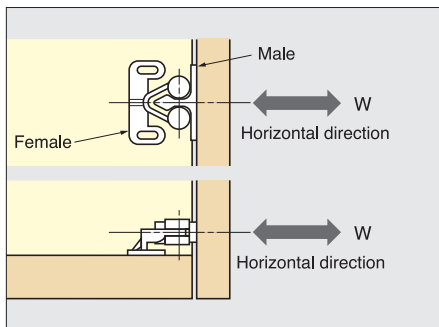

The catch force is measured when the force (W) is gently applied in the direction of the arrow under the condition indicated by the figure. Note: Misalignment of the male and female parts may cause the catch force to decrease or parts failure.

**TEST** RETAINING FORCE TEST (TEST 11)

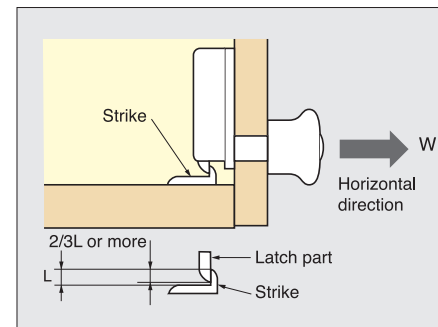

The retaining force is measured when the force (W) is gently applied in the direction of the arrow under the condition indicated by the figure. Note: Latch and strike must be engaged at least 2/3L or more. (See the figure.)

TEST METHODS

**TEST** LOAD CAPACITY TEST (TEST 12)

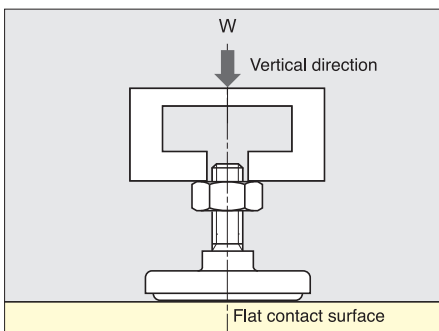

The load capacity is measured when the force (W) is applied in the direction of the arrow under the condition indicated in the figure. Product may break or distort if the contact surface is not flat.

**TEST** LOAD CAPACITY OF CASTER (TEST 13)

The load capacity is based on a flat steel floor surface. Following is the safety factor which should be taken into consideration in case of using four casters:



$$\text{Proper load kg (lbs)} = \text{Load capacity value kg (lbs)} \times 4 \text{ (each)} \times 0.75$$

The safety factor will vary depending on the conditions of use such as the rolling surface, rolling speed, etc. When using under adverse conditions, please test the casters in the intended application.

**TEST** PULL LOAD TEST (TEST 14)

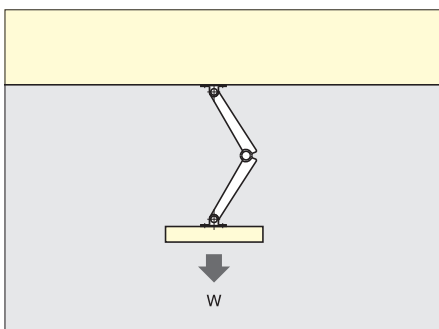

The pull load capacity is measured when the force (W) is gently applied in the direction of the arrow under the condition indicated by the figure.

**TEST** COMPRESSION LOAD TEST (TEST 15)

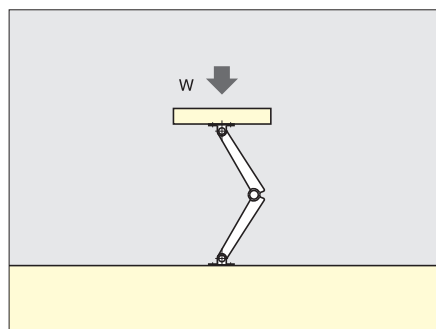

The compression load capacity is measured when the force (W) is gently applied in the direction of the arrow under the condition indicated by the figure.

**TEST** PERMISSIBLE LOAD OF FASTENER (TEST 16)

The permissible load is based on the following safety factor:

$$\text{Permissible load kg (lbs)} = \text{Ultimate Load} \div 3$$

The safety factor will vary depending on the conditions of use. When used under adverse conditions, please test the fastener in intended application.

**TEST** HOOK LOAD CAPACITY TEST (TEST 17)

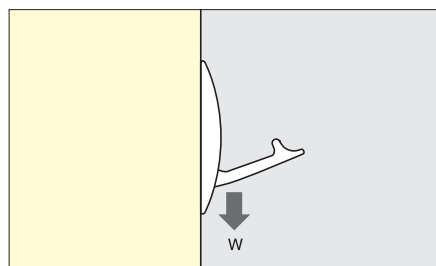

The load capacity is measured when the force (W) is gently applied in the direction of the arrow under the condition indicated by the figure.

The load capacity is based on the following safety factor:

$$\text{Load capacity kg (lbs)} = \text{Ultimate Load} \div 3$$

However, the safety factor will vary depending on the conditions of use. When used under adverse conditions, please test the hook in intended application.

## MATERIALS

Material	Type	Characteristics
430 Stainless Steel	Ferretic	18% Chromium (Cr) added to steel. Commonly used because of its excellent formability and cost performance. Low corrosion resistance compared to 304 grade.
304 Stainless Steel	Austenitic	Most common grade which contains 18% chromium and 8% nickel, also called 18/8 stainless steel. Low carbon content, excellent formability and weldability with good corrosion resistance.
316 Stainless Steel	Austenitic	Nickel (Ni) and Molybdenum (Mo) added to maximize corrosion resistance. Better acid and pitting resistance than 304 grade. Also has high strength at high temperature.
Zinc Alloy	-	This is an alloy having zinc (Zn) as main component along with other materials such as aluminum (Al), copper (Cu), magnesium (Mg), iron (Fe), etc. This alloy is widely used along with aluminum alloy for die-casting. Zinc alloy facilitates the manufacturing of product with high dimensional accuracy, beautiful cast surface, and it can be plated for superior corrosion resistance. Zinc Alloy also has superior mechanical characteristics such as high tensile strength, compressive strength, hardness, bend (flexural) strength, modulus of elasticity, etc. Also zinc alloy can be plated with good corrosion resistance.
Aluminum Alloy	-	This is an alloy having aluminum (Al) as a main component along with other materials such as copper (Cu), silicon (Si), iron (Fe), magnesium (Mg), zinc (Zn), etc. Aluminum alloy is the most widely used material today for die-casting. This alloy facilitates the manufacturing of lightweight product having appropriate mechanical characteristics and corrosion resistance. Also it has good physical characteristics such as fine thermal conductivity, and also the characteristics do not change at low temperature.
Brass	-	Brass is an alloy having copper (Cu) and zinc (Zn) as the main components. It has yellow (or golden) color and good cutting characteristics. This alloy is easy to fabricate and is often used for the body of locks, hinges, handles, etc.

Material	Acronym	Characteristics
ABS Resin	ABS	Thermal plastic developed to enhance the impact resistance of polystyrene. ABS can be plated.
Polyamide	PA	Very resistant to wear and abrasion suitable for parts like gears and bearings. Also has good chemical and oil resistance.
Polypropylene	PP	Strong against organic solvent. Difficult for adhesion and painting. Resistant to bending stress ideal for bending applications.
Polyacetal	POM	Superior abrasion resistance. Good tensile/bending strength and elasticity.
Polyethylene	PE	Low material cost. Excellent formability usable for various application. Has very low water absorption rate, suitable for water resistant purpose.
Polycarbonate	PC	High impact resistance and good dimensional stability for high precision. Also has high transparency.



Name	Characteristics
Zinc Plating	Zinc plating is commonly used on steel to prevent oxidation. Chromate is generally applied over zinc to enhance corrosion resistance.
Chromate Conversion Coating	Major coating mainly applied on parts after zinc plated or cadmium plated. Parts are immersed in a solution mainly consisting of chromic acid or heavy chromic acid to create the coating. This is used to improve corrosion resistance and appearance of metals, metal coloration, and is also used as a pre-treatment for painting. Various chromate coatings are developed such as yellow chromate (rainbow color), clear chromate, black chromate, green chromate, etc.
Chrome Plating	Common electroplating for various industrial purposes. Reflective finish can be achieved by polishing. High hardness and good corrosion resistance along with thermal resistance, abrasion resistance and good adhesion characteristics. Generally used as final finish for various decorative parts and products due to its uniquely deep coloration.
Nickel Plating	Nickel is commonly used for decorative and anti-corrosion purpose because of its stability against air or humidity compared to iron. However, since the surface of the nickel plating will slightly discolor through exposure to air, chrome is often used after nickel to keep the finish/color. Nickel plating has moderate hardness / corrosion-resistance and widely used on industrial application.
Alumite or Anodizing (Anodic Oxidation Film Processing)	Also called the "anodic oxidation film processing". This process thickens and toughens natural oxide layer on metal, commonly applied to aluminum for corrosion resistance and dyeing. In aluminum anodizing, aluminum object serves as the anode (the positive electrode) when electrolyzed in the sulfuric acid. This will create a layer of porous oxide film which has high electric insulation and abrasion resistance. The film is normally transparent when it is thin, although it becomes dull as the thickness increases. The pores produced by anodizing are closed by a process called sealing, which is done by high-pressurized or boiling-hot deionized water. This process fills the pores and creates a thin layer that is corrosion resistant, suitable for various aluminum parts / products.

\* Hexavalent-Chromium (CR6) Free

Sugatsune is strictly controlling the use of chemicals that would adversely impact the environment. We are designing and developing products with minimum use of materials which has adverse environmental impact. Hexavalent chromium compound is especially known for its adverse effects on the human body. We are eagerly substituting this Hexavalent-chromium (CR6) with the less toxic substance Trivalent-chromium (CR3).



Item Name	Description	Page
<b>1</b>		
1-1122	PUSH LOCK	446
1-1212	VENTILATOR	461
1-2211	VENTILATOR	461
1-2222	VENTILATOR	462
1-555-2	ADJUSTABLE KNUCKLE CATCH	60
100-46/14, C46/14 SUS 304B	CONCEALED HINGE (14mm OVERLAY)	314
100-46/19, C46/19 SUS 304B	CONCEALED HINGE (19mm OVERLAY)	314
100-46/9, C46/9 SUS 304B	CONCEALED HINGE (9mm OVERLAY)	315
100-P3A, P4A/32, P4A/32-3W SUS 304B	MOUNTING PLATE	315
1100GL	GLASS DOOR CAM LOCK	448
149 SERIES	PUSH LOCK FASTENER (PUSH-TURN TYPE)	93
<b>2</b>		
2000-150	CONCEALED HINGE	320
2000-MIGNON	CONCEALED HINGE	320
2000RV-2	CONCEALED HINGE	320
2100B	PUSH LOCK	445
2110B	PUSH LOCK	445
2150B	PUSH LOCK	446
2200QL	CABINET LOCK (W/INDICATOR)	447
251F, 151F	PUSH LOCK FASTENER (LARGE/FLUSH TYPE)	90
252F, 152F	PUSH LOCK FASTENER (MINI/FLUSH TYPE)	91
255F, 155F	PUSH LOCK FASTENER (MINI/BUTTON TYPE)	92
272SL	3/4 EXTENSION SLIDE	178
273SL	FULL EXTENSION SLIDE	171
26700	STAINLESS STEEL FOLDING RING PULL	374
26700	STAINLESS STEEL FOLDING RING PULL	375
26900	STAINLESS STEEL FOLDING RING PULL	374
26901	STAINLESS STEEL FOLDING RING PULL	374
27900, 27800	BUTT HINGE	270
28000, 28500	BUTT HINGE	270
28100	BUTT HINGE	272
28300, 28400	BUTT HINGE	269
2H	HOOK	222
2LC	HANDLE	344
2LC-80Ti, 120Ti, 150Ti	HANDLE	29
<b>3</b>		
388	FOLDING BRACKET	237
3535SS, 4040SS	BUTT HINGE	274
3800S	SHEET METAL CAM LOCK	442
3810S	CABINET LOCK	447
3LC	HANDLE	345
<b>4</b>		
4060	PUSH TO OPEN SLIDE - SIDE MOUNT	186
4061	PUSH TO OPEN SLIDE - UNDER MOUNT	187
4070	SOFT CLOSE SLIDE - SIDE MOUNT	184
4071	SOFT CLOSE SLIDE - UNDER MOUNT	185
4545BSS	BUTT HINGE (W/BALL BEARING)	274
4LC	HANDLE	344

Item Name	Description	Page
<b>5</b>		
5302	FULL EXTENSION SLIDE	163
50704, 50706	LEAF HINGE	269
<b>6</b>		
6300	PUSH LOCK	446
<b>8</b>		
8000N	CABLE GROMMET	458
8001, 8002	CABLE GROMMET	456
<b>9</b>		
900	SHEET METAL CAM LOCK	442
980640	FOLDING RING PULL (SPRING LOADED)	375
980641, 980642	FOLDING RING PULL (SPRING LOADED)	375
<b>A</b>		
A SERIES	KNOB	382
AD-438	BASE	437
AD-559	GLIDE BASE	437
ADHS, ADH	HEAVY DUTY LEVELING GLIDE	429
ADPS	STAINLESS STEEL LEVELING GLIDE	430
ADZS, ADZ	STAINLESS STEEL LEVELING GLIDE WASHER	430
AF	CASTER WITH LEVELING GLIDE	400
ALU25-20	CABLE GROMMET	456
AM	HANDLE	358
AOT35	RECESSED PULL	384
AP-BR06	BELT REEL PARTITION	466
AP-DM , AP-DH	SHELF STANDARD	249
AP-EC20	END CAP	247
AP-EC20	END CAP	249
AP-FB20	SHELF SUPPORT	249
AP-FC20	SHELF SUPPORT CAP	249
AP36	STAINLESS STEEL GLIDE BASE	437
APD-KH	VENTILATOR	453
AR2	3/4 EXTENSION SLIDE	189
AR2-K	3/4 EXTENSION SLIDE (W/HOLD-OUT DETENT)	189
AR3	FULL EXTENSION SLIDE	188
AR3-16	ALUMINUM MINI SLIDE	190
AR3-K	FULL EXTENSION SLIDE (W/HOLD-OUT DETENT)	188
ARL2-16	ALUMINUM MINI GUIDE	190
ART973	CABLE GROMMET	458
ARW2-16	ALUMINUM MINI SLIDE (2-WAY)	190
AS-68	STAINLESS STEEL COUNTERPLATE	51
AS-6M, 8M, 10M	FIXING NUTS FOR ALMINUM PROFILE	25
AS-AF-25D	PIVOT HINGE	284
AS-AJ	GLIDE BASE	437
AS-C	CORNER CAP PAT.P	25
AS-H30	BRACKET FOR HANDLE	363
AS-HG-AL	BUTT HINGE	283
AS-HG-AL-N	LIFT-OFF HINGE	284
AS-HG-IS	BUTT HINGE	280
AS-HG-SUS	BUTT HINGE	283
AS-NSDX	NSDX Brackets for stay	125
ASD	VENTILATOR	460
ASM	VENTILATOR	459
AST	VENTILATOR	459

Item Name	Description	Page
AST-160, 210	VENTILATOR	460
AT-100	RECESSED PULL	372
AT-70	RECESSED PULL	372
ATL-64	FLUSH SLAM LATCH	95
ATS-100	RECESSED PULL	371
<b>B</b>		
B	HOOK	221
B-KR	SLIDE BOLT	69
BCT	TENSION CATCH	62
BCT-60W	TENSION CATCH	63
BCTS	STAINLESS STEEL TENSION CATCH	62
BCU	TENSION CATCH	63
BH	RECESSED BALL CASTER	420
BHB	SMALL RECESSED BALL CASTER	420
BJ610	BASE	423
BL-40, BL-60	BARREL BOLT	72
BL-40S, BL-60S	SPRING LOADED BARREL BOLT	71
BL-70Y	BOX LATCH (W/LOCK)	448
BLL	SPRING LOADED BAR LATCH	75
BLS	SPRING LOADED BARREL BOLT	71
BLT	BAR LATCH	75
BM	SURFACE MOUNT BALL CASTER	420
BN	LIFT-OFF HINGE	291
BOS	FOLDING BRACKET (W/STOPPER)	235
BRB-A4-15CR, BRF	KNURLED KNOB	387
BRT	KNURLED KNOB	386
BRT-L6	KNURLED KNOB	385
BRT-NB	KNURLED KNOB	386
BRT-NC	KNURLED KNOB	386
BS	BARREL BOLT	72
BS-SL	SPRING LOADED BARREL BOLT	74
BSS	SPRING LOADED BARREL BOLT	73
BSS2/BSS3	SPRING LOADED BARREL BOLT	73
BT, BTK	BRACKET	238
BTO	FOLDING BRACKET	236
BY	BRACKET	235
<b>C</b>		
C	HOOK	221
CA	PARTS SEPARABLE CASTER (W/GLIDE)	399
CBL-D402	3/4 EXTENSION SLIDE	206
CBL-D409	ALMINUM LINEAR BALL BEARING GUIDE	212
CBL-D444	FULL EXTENSION SLIDE	206
CBL-D48	ALMINUM LINEAR BALL BEARING GUIDE	211
CBL-D500	FULL EXTENSION SLIDE	205
CBL-E1012	FULL EXTENTION SLIDE	196
CBL-E1014	ULTRA OVER EXTENSION SLIDE	198
CBL-E1020	FULL EXTENSION SLIDE	196
CBL-E1400	FULL EXTENSION SLIDE	201
CBL-E1700	FULL EXTENSION SLIDE	197
CBL-E1708	FULL EXTENTION SLIDE	193
CBL-E1902	FULL EXTENSION SLIDE	197
CBL-E1904	ULTRA OVER EXTENTION SLIDE	199
CBL-E1908	FULL EXTENSION SLIDE	193

Item Name	Description	Page
CBL-E28	LINEAR BALL BEARING GUIDE	211
CBL-E46	LINEAR BALL BEARING GUIDE	208
CBL-E47	LINEAR BALL BEARING GUIDE	210
CBL-E48	LINEAR BALL BEARING GUIDE	209
CBL-E50	LINEAR BALL BEARING GUIDE	209
CBL-E53	LINEAR BALL BEARING GUIDE	210
CBL-E72	LINEAR BALL BEARING GUIDE	208
CBL-E98	LINEAR BALL BEARING GUIDE	207
CBL-R20	3/4 EXTENSION SLIDE	205
CBL-R26	3/4 EXTENSION SLIDE	201
CBL-R53	3/4 EXTENSION SLIDE	200
CBL-R71	3/4 EXTENSION SLIDE	199
CBL-RA31	FULL EXTENSION SLIDE	204
CBL-RA41	FULL EXTENSION SLIDE	202
CBL-RA44	FULL EXTENSION SLIDE	203
CBL-RA554R	ULTRA OVER EXTENSION SLIDE	202
CBL-RA5R	FULL EXTENSION SLIDE	200
CBL-RA654	ULTRA OVER EXTENSION SLIDE	204
CBL-RA7R	FULL EXTENSION SLIDE	198
CBL-RT3D	FULL EXTENSION SLIDE	203
CBL-ST448	FULL EXTENSION SLIDE	195
CBL-ST45	STAINLESS STEEL LINEAR BALL	207
CBL-ST508	FULL EXTENTION SLIDE	194
CBL-ST58	3/4 EXTENSION SLIDE	194
CBL-ST658	ULTRA OVER EXTENSION SLIDE	195
CHN	ADJUSTABLE DRAW LATCH	79
CL-24	CABLE GROMMET	458
CLI-31	SHEET METAL CAM LOCK	443
CM-2B	MINI MAGNETIC CATCH (SNAP-IN TYPE)	39
CUJ-200	SHOCK-ABSORBING CASTER (PLATE TYPE)	398
CUK-200	SHOCK-ABSORBING CASTER	398
<b>D</b>		
D-S-A	BUTT HINGE	268
D-S-B	BUTT HINGE	268
D-S-C	BUTT HINGE	268
DA	DOUBLE ACTION SPRING HINGE	296
DBN	KNURLED KNOB	387
DC	DAMPER CATCH	97
DCY-34	SHEET METAL CAM LOCK	441
DH-60RC	BUTT HINGE	279
DH60	BUTT HINGE	280
DH60N	BUTT HINGE	280
DL	HANDLE	355
DS	HANDLE	355
DS-H	LARGE UTILITY HOOK	219
DZ-270	BUTTERFLY HOOK	229
<b>E</b>		
EA	LEVELING GLIDE (PARTS SEPARABLE)	433
EB-303/EP	FOLDING BRACKET	237
EC	HANDLE	354
EC-H	HANDLE	348
EC-Y	HANDLE	345
ECH	HANDLE	354
EK-R	HANDLE	351



Item Name	Description	Page
EK-S	HANDLE	350
EL	HOOK	223
EN-K	LATCH HOOK	226
EN-R100F	LATCH HOOK	227
EN-R80	LATCH HOOK	226
EN-R80-K	LATCH HOOK	227
EP	HOOK	223
ES-611	RECESSED PULL	364
ESN-195	NON-MAGNETIC MINI TOUCH LATCH	65
ESR-1	3/4 EXTENSION SLIDE	175
ESR-3813	FULL EXTENSION SLIDE	165
ESR-4513	FULL EXTENSION SLIDE	164
ESR10	FULL EXTENSION SLIDE	162
ESR2	3/4 EXTENSION SLIDE	180
ESR2021	3/4 EXTENSION SLIDE	179
ESR2031	FULL EXTENSION SLIDE	172
ESR3	FULL EXTENSION SLIDE	173
ESR5	3/4 EXTENSION SLIDE	174
ESR7	FULL EXTENSION SLIDE	167
ESR9	LINEAR BALL BEARING GUIDE	182
EU	FORK HOOK	222
EW	HOOK	224
EX-100N	DUAL BRAKE SYSTEM CASTER (THREADED BOLT TYPE)	397
EX-100PS, P	DUAL BRAKE SYSTEM CASTER (PLATE TYPE)	397
EXCEL	KNOB	382
EY-R	HEAVY DUTY FOLDING PAD EYE	229
EZS-ELAN	LIFT ASSIST STAY	112
<b>F</b>		
F-100	LID STAY	151
F-150, 200, 250	LID STAY	151
F-300	LID STAY	151
FA45NS, N	TWIN WHEEL CASTER (THREADED BOLT TYPE)	418
FA45PS, P	TWIN WHEEL CASTER (PLATE TYPE)	418
FA55-FIX	CASTER BRACKET	419
FA55N	TWIN WHEEL CASTER (THREADED BOLT TYPE)	416
FA55PS, P	TWIN WHEEL CASTER (PLATE TYPE)	416
FAU55N	TWIN WHEEL CASTER (THREADED BOLT TYPE)	414
FAU55PS, P	TWIN WHEEL CASTER (PLATE TYPE)	414
FB	HANDLE	353
FC	HOOK	224
FC-50 Ti, 65 Ti	HOOK	30
FHS	BUTT HINGE	274
FK-S, FM-S	PITCH ADJUSTABLE HANDLE	356
FL2	SLIDE BOLT	68
FL4	SLIDE BOLT	68
FM46S	MAGNETIC CATCH	48
FP45NS, N	TWIN WHEEL CASTER (THREADED BOLT TYPE)	419
FP45PS, P	TWIN WHEEL CASTER (PLATE TYPE)	419
FP55N	TWIN WHEEL CASTER (THREADED BOLT TYPE)	417
FP55PS, P	TWIN WHEEL CASTER (PLATE TYPE)	417

Item Name	Description	Page
FPU55NS, N	TWIN WHEEL CASTER (THREADED BOLT TYPE)	415
FPU55PS, P	TWIN WHEEL CASTER (PLATE TYPE)	415
FT-120,150	HANDLE	346
FT-65,80,100	HANDLE	346
FT-200,280	LARGE HANDLE	347
FT-110S	HANDLE	346
FT-S	LARGE HANDLE	347
<b>G</b>		
GDSR144-R	DRAWER DAMPER	183
GH-34/0	INSET GLASS DOOR HINGE	305
GH-34/0/S	INSET GLASS DOOR HINGE	303
GH-34/8	HALF OVERLAY GLASS DOOR HINGE	304
GH-34/8/S	HALF OVERLAY GLASS DOOR HINGE	303
GH-36/NCR	INSET GLASS DOOR LIFT-OFF HINGE	305
GH34-0CR-K	INSET GLASS DOOR HINGE	307
GH34-8CR-K	HALF OVERLAY GLASS DOOR HINGE	306
GHC-34/8	HALF OVERLAY GLASS DOOR HINGE (W/CATCH)	304
GHC34-8CR-K	HALF OVERLAY GLASS DOOR HINGE (W/CATCH)	306
GTS-300	SPRING LOADED BRACKET	236
GX-W50GN	TWIN WHEEL CASTER (THREADED BOLT & PLATE)	412
GX-W50GP	TWIN WHEEL CASTER (THREADED BOLT & PLATE)	412
GX-W50K	TWIN WHEEL CASTER (NON-SWIVEL)	413
GX50N12S, N12	TWIN WHEEL CASTER (THREADED BOLT TYPE)	411
GX50PS, P	TWIN WHEEL CASTER (PLATE TYPE)	411
GX60N12S, N12	TWIN WHEEL CASTER (THREADED BOLT TYPE)	410
GX60PS, P	TWIN WHEEL CASTER (PLATE TYPE)	410
GX75N16S, N16	TWIN WHEEL CASTER (THREADED BOLT TYPE)	409
GX75PS, P	TWIN WHEEL CASTER (PLATE TYPE)	409
<b>H</b>		
H-42-B	WIRE PULL	360
H-42-B-9	WIRE PULL	360
H-42-C	WIRE PULL	361
H-42-F14	WIRE PULL	361
H-75-BL-100	WIRE PULL	363
H-75-C	HANDLE	362
H42-BT-2, 4, 15	WIRE PULL	28
H42-CT-2, 4, 15	WIRE PULL	28
H42-Z	BRACKET FOR HANDLE	363
H95TM	CONCEALED HINGE (CLIP-ON)	312
H95TS	CONCEALED HINGE (CLIP-ON)	313
HBFN	HORIZONTAL BI-FOLDING DOOR MECHANISM	137
HC-30	SLIDING DOOR LATCH	100
HC-30H	SLIDING DOOR LATCH W/INDICATOR	101
HC-30HL	SLIDING DOOR LATCH W/INDICATOR	103
HC-30L	SLIDING DOOR LATCH	102
HC-30R	SLIDING DOOR LATCH	100
HC-65	SLIDING DOOR LATCH	103
HC-70	SLIDING DOOR LATCH	101
HC-70H	SLIDING DOOR LATCH W/INDICATOR	102
HC-85SS	SLIDING DOOR LATCH	104

Item Name	Description	Page
HCT-150	TRUNK HANDLE	376
HDS-10	HEAVY DUTY SOFT-DOWN STAY	127
HDS-20	HEAVY DUTY SOFT-DOWN STAY	128
HDS-30	HEAVY DUTY SOFT-DOWN STAY	129
HDSN-30	HEAVY DUTY SOFT-DOWN STAY	130
HES3D-120	3WAY ADJUSTABLE CONCEALED HINGE	319
HES3D-190	3WAY ADJUSTABLE CONCEALED HINGE	318
HF	SWIVEL	462
HG	LOW PROFILE HEAVY DUTY CASTER	401
HG-BF1	BUTT HINGE	271
HG-BF3	BUTT HINGE (W/SPRING)	297
HG-BH	DOUBLE ACTION HINGE	317
HG-CSH63	DETENT HINGE (WITH or WITHOUT DAMPER)	299
HG-CSH63	DETENT HINGE (WITH or WITHOUT DAMPER)	328
HG-CV	CLEAN ROOM HINGE (W/BUSHING)	281
HG-CV-127	HEAVY DUTY CLEAN ROOM HINGE	282
HG-CV65N	CLEAN ROOM HINGE (W/BUSHING)	281
HG-FH128	DETENT HINGE	298
HG-IT	TORQUE HINGE	321
HG-JH	SOFT-CLOSE DAMPENING HINGE	330
HG-JH14-50	STAINLESS STEEL SOFT-CLOSE DAMPENING HINGE	331
HG-JH210	STAINLESS STEEL LIFT ASSIST HINGE	328
HG-JHM16	SOFT-CLOSE DAMPENING HINGE	333
HG-JHM20	SOFT-CLOSE DAMPENING HINGE	332
HG-JHW / HG-JHWG	SOFT-CLOSE DAMPENING HINGE	329
HG-KH	HEAVY DUTY FLAG HINGE (W/BALL BEARING)	266
HG-KM	HEAVY DUTY FLAG HINGE (W/BALL BEARING)	266
HG-MH	TABLETOP PIANO HINGE	277
HG-OT	QUICK RELEASE HINGE	294
HG-P100	CLEAN ROOM HINGE	282
HG-PV-30C	PIVOT HINGE	295
HG-PV60AC	SPRING LOADED PIVOT HINGE	295
HG-S	SWIVEL TORQUE HINGE	325
HG-SH	BUTT HINGE (W/SPRING)	297
HG-T30S15	TORQUE HINGE (DUAL AXIS)	322
HG-T70S30	TORQUE HINGE (DUAL AXIS)	322
HG-TA	TORQUE HINGE	323
HG-TB	TORQUE HINGE	323
HG-TQA	ONE WAY TORQUE HINGE	326
HG-TS	STAINLESS STEEL TORQUE HINGE	324
HG-TU	HIDDEN TORQUE HINGE	324
HG-YC105	DETENT HINGE	299
HG-YJ50	DETENT HINGE	298
HG-YS65C	CONCEALED HINGE (W/STAY)	300
HH-AS2	RECESSED PULL	367
HH-AS2 Ti	RECESSED PULL	29
HH-AS3	RECESSED PULL	367
HH-D	RECESSED PULL	366
HH-DS	RECESSED PULL	365
HH-FB, HH-FC	RECESSED PULL	367
HH-K	RECESSED PULL	365
HH-KL160	RECESSED PULL	366
HH-KP150	RECESSED PULL	366

Item Name	Description	Page
HH-KS	RECESSED PULL	365
HH-M	MEGA-RECESSED PULL (WITH BAR HANDLE)	364
HH-P130	RECESSED PULL	370
HH-PS99	RECESSED PULL (BACK MOUNT)	371
HH-QTR	RECESSED PULL	370
HHC-85	SLIDING DOOR LATCH	104
HJ	HOOK	222
HJT	HOOK	222
HK	FOLDING HANDLE	356
HN	RECESSED PULL	373
HNH	LIFT-OFF HINGE (WELD-ON)	289
HO500	BASE	422
HP	STAINLESS STEEL HASP	77
HP-635, 645, 660	WELD-ON STAINLESS STEEL HASP	77
HP-635S, 645S, 660S	STAINLESS STEEL HASP	77
HP-AK	LATCH HASP	76
HQ	BUTT HINGE	279
HR	HATCH PULL	380
HR	LOW PROFILE HEAVY DUTY CASTER	402
HR-R	HATCH PULL	380
HR35	LEVER BOLT	70
HS	LID STAY	150
HS-550	BASE	421
HT-160	CONCEALED HINGE (CLIP-ON)	310
HT-160THV2	CONCEALED HINGE (SNAP-ON)	311
HT-65PB	LOW PROFILE HEAVY DUTY CASTER	402
<b>I</b>		
I-66	CONCEALED HINGE	317
I-90	CONCEALED HINGE	317
I100	HANDLE	343
I1014	HANDLE	342
I1020	HANDLE	342
I120	HANDLE	343
I163	HANDLE	343
I333	HANDLE	342
<b>J</b>		
JC-24,JC-26	KNUCKLE CATCH	61
JC-T50	KNUCKLE CATCH	61
JCU	KNUCKLE CATCH(MORTISE TYPE)	61
JCU-F	SNAP-IN KNUCKLE CATCH	61
JF-45, 70, 110	LARGE UTILITY HOOK	216
JF-50, 80, 120	LARGE UTILITY HOOK	217
JF-T	SWING HOOK (W/FRICTION)	228
JFT-180, 260	LARGE UTILITY HOOK	217
<b>K</b>		
KA-60	MULTI-ANGLE LOCKING STAY	300
KB	HANDLE	354
KB-F-70	HOOK	224
KB-F-75	HOOK	224
KB-H	HOOK	223
KC-R	HANDLE	350
KC-S	HANDLE	350
KHA	BUTT HINGE	267



Item Name	Description	Page
KK-B	KNOB	383
KK-H	HANDLE	359
KK-M	HANDLE	358
KK-T	KNOB	383
KMS	MAGNETIC CATCH (RUBBER ROLL TYPE)	50
KN	LIFT-OFF HINGE	289
KPH	HANDLE	353
KR-50	SLIDE BOLT	69
KR65	SLIDE BOLT	70
KR75	SLIDE BOLT	70
<b>L</b>		
L	LID STAY	144
L-100S,L-140S	ULTRA MINI LID STAY	142
L-195A Ti, 270A Ti	LID STAY	30
L-200P	LOW PROFILE LID STAY	143
L-FS140	MINI LID STAY (W/LOCK)	143
L-FS350A	MULTI-ANGLE LID STAY (W/LOCK)	147
L-FSP350A	MULTI-ANGLE STAY (W/LOCK)	148
L-FSS350A	MULTI-ANGLE LID STAY	148
L-S-BT	MOUNTING BRACKET	142
L-SL140	MINI LID STAY (W/LOCK)	143
LB	LID STAY	145
LB-215, 290	LID STAY	145
LB-CV215A	LID STAY (CLEAN ROOM)	147
LB-S	HEAVY DUTY LID STAY	146
LBTS	HEAVY DUTY MULTI-ANGLE LID STAY	146
LC-48	FLUSH SLAM LATCH	94
LC-65A	FLUSH SLAM LATCH	94
LC-PK32-L	QUICK RELEASE LATCH WITH LOCKING	98
LC-PK32-K	PANEL LATCH WITH LOCKING	99
LF-12	HANDLE	362
LH-203	LATCH HANDLE	94
LHN	PIANO HINGE	276
LIN-X450	MonoFlat LIN-X hinge	286
LIN-X450,600	MonoFlat LIN-X hinge	285
LIN-X600	MonoFlat LIN-X hinge	287
LJ-61	FLUSH SLAM LATCH	96
LK	LID STAY	140
LL-66	LEVER LATCH	67
LL-66S	STAINLESS STEEL LEVER LATCH	67
LN72S	CABLE GROMMET	453
LSA, LSB	BUTT HINGE	267
LSD	PIANO HINGE	277
LSF	BUTT HINGE	269
LSK	STAINLESS STEEL WELD-ON BUTT HINGE	275
LSN	PIANO HINGE (WELD-ON)	276
LSP	LID STAY (W/LOCK)	144
LSS	BUTT HINGE	272
LSW	LIFT-OFF HINGE	288
LSX	LIFT-OFF HINGE	288
<b>M</b>		
MA-5	TABLETOP HINGE	278
MC-0051	MAGNETIC CATCH	49
MC-0083	HEAVY DUTY MAGNETIC CATCH	37

Item Name	Description	Page
MC-0083D	HEAVY DUTY MAGNETIC CATCH	37
MC-110NF	STRONG MAGNETIC CATCH	38
MC-111, 112, 113	MAGNETIC CATCH	42
MC-125	MAGNETIC TOUCH LATCH	53
MC-158, MC-159	ULTRA THIN & STRONG MAGNETIC CATCH	35
MC-28	NON-MAGNETIC TOUCH LATCH	66
MC-37F	NON-MAGNETIC TOUCH LATCH	66
MC-84	MAGNETIC CATCH	48
MC-E	MAGNETIC CATCH	46
MC-EA	MAGNETIC CATCH	48
MC-FM20S	MAGNETIC CATCH	49
MC-FM20W	MAGNETIC CATCH	49
MC-FP5S	MAGNETIC CATCH	40
MC-FS	THIN MAGNETIC CATCH (SNAP-IN TYPE)	41
MC-FS, MC-FP	MAGNETIC CATCH	40
MC-FS17W	MAGNETIC CATCH (SNAP-IN TYPE)	40
MC-H	STRONG MAGNETIC CATCH	50
MC-IS	MAGNETIC CATCH	41
MC-IS4F	MAGNETIC CATCH	41
MC-JM45	SEALED MAGNETIC CATCH	34
MC-JM49	STAINLESS STEEL COUNTERPLATE	51
MC-JM50	SEALED MAGNETIC CATCH	34
MC-JM63G	SEALED MAGNETIC CATCH	34
MC-JM74SW-30	SEALED MAGNETIC CATCH (W/SWITCH)	54
MC-K	MAGNETIC CATCH	46
MC-S78	MAGNETIC CATCH	43
MC-S88	MAGNETIC CATCH	43
MC-SM10	MAGNETIC CATCH	43
MC-SP	MAGNETIC CATCH	46
MC-SS30	MAGNETIC CATCH (SNAP-IN TYPE)	39
MC-YN001	ULTRA THIN MAGNETIC CATCH	35
MC-YN001U	COUNTER PLATE	51
MC-YN003	THIN MAGNETIC CATCH	42
MC-YN005	STAINLESS STEEL MAGNETIC CATCH	37
MC-YN005HP	HIGH TEMPERATURE MAGNETIC CATCH	36
MC-YN015S	ULTRA THIN STAINLESS STEEL MAGNETIC CATCH	35
MC-YS	MINI MAGNETIC CATCH	48
MC-YSW	MAGNETIC CATCH (SNAP-IN TYPE)	39
MC0083HP	HIGH TEMPERATURE MAGNETIC CATCH	36
MC009	MAGNETIC CATCH	47
MC0097	MAGNETIC CATCH	47
MC0099	MAGNETIC CATCH	38
MC0750	MAGNETIC CATCH	42
MC12, MC12S	MAGNETIC CATCH	44
MC16, MC16S	MAGNETIC CATCH	45
MC17, MC17S	MAGNETIC CATCH	45
MC200	MAGNETIC CATCH	47
MC50	MAGNETIC CATCH	45
MC800	MAGNETIC CATCH	50
MCH	HEAVY DUTY MAGNETIC CATCH	38
MDH	HANDLE	357
MDSF	SWAY FOOT - LEVELING GLIDE	428
MG	HANDLE	344

Item Name	Description	Page
MG	WIRE PULL	361
MH-83	TABLETOP HINGE	278
MKP	LEVELING GLIDE	435
MKPLS	STAINLESS STEEL LONG-STEM LEVELING GLIDE	431
MKPS	STAINLESS STEEL LEVELING GLIDE	434
MKR	LEVELING GLIDE (W/RUBBER PAD)	435
MKRL	LEVELING GLIDE	432
MKRLS	STAINLESS STEEL LONG-STEM LEVELING GLIDE	431
MKRS	STAINLESS STEEL LEVELING GLIDE (W/RUBBER PAD)	434
ML-120	MAGNETIC TOUCH LATCH (LONG STROKE)	52
ML-30S	MAGNETIC TOUCH LATCH	53
ML-30W	MAGNETIC TOUCH LATCH	53
ML-80	MAGNETIC TOUCH LATCH	52
MN	LEVELING GLIDE	436
MP	LARGE HANDLE	340
MPH-20-5G2	CELL PHONE HINGE (W/DETENT)	327
MPH-22G	CELL PHONE HINGE (W/DETENT)	327
MPH-30	CELL PHONE HINGE (W/DETENT)	327
MPH-H30-5TN	CELL PHONE HINGE (W/DETENT)	327
MRS20, MR-20CS	MINI GUIDE BLOCK & RAIL	191
MRS30, MR-50C	GUIDE BLOCK & RAIL	192
MUD-140	TRUNK HANDLE	376
MX-125N	DUAL BRAKE SYSTEM CASTER (THREADED BOLT TYPE)	396
MX-125PS, P	DUAL BRAKE SYSTEM CASTER (PLATE TYPE)	396
<b>N</b>		
NAC	KNUCKLE CATCH	60
NAL	SHEET METAL CAM LOCK	444
NAL-S	SHEET METAL MINI CAM LOCK	444
NB01	MAGNETIC CATCH (OPTIONAL SNAP-IN HOLDER)	41
NF-60	RECESSED HOOK	233
NF-R64	RECESSED HOOK	232
NH-40	LIFT-OFF HINGE	290
NMS	HIGH POWER RUBBER MAGNETIC CATCH	50
NO990	HIGH SECURITY LOCK	441
NPG	SHOCK-ABSORBING CASTER (PLATE TYPE)	394
NPR	SHOCK-ABSORBING CASTER (RIGID TYPE)	395
NPT	SHOCK-ABSORBING CASTER (THREADED BOLT TYPE)	395
NS	PLASTIC CASTER	420
NS2	NON-MAGNETIC MINI TOUCH LATCH	64
NSD-10	ADJUSTABLE SOFT-DOWN STAY	121
NSD-20	ADJUSTABLE SOFT-DOWN STAY	122
NSD-35	ADJUSTABLE SOFT-DOWN STAY	123
NSDX	NSDX Arm Mounting Plates	125
NSDX-10 (R/L)K/TV	ADJUSTABLE SOFT-DOWN STAY (SHORT-ARM)	124
NT	PLASTIC CASTER	420
<b>O</b>		
OLY	BUTT HINGE	275
OLYA	BUTT HINGE	275
OP-150	RECESSED PULL	373

Item Name	Description	Page
<b>P</b>		
P-102H/SS	DRAW LATCH	89
P-1040/SS	DRAW LATCH	89
P10	FLUSH SLAM LATCH	95
P100	DRAW LATCH	86
P11	FASTENER	87
P3	DRAW LATCH	85
P3	DRAW LATCH	86
P3-10N	DRAW LATCH	85
P34	FASTENER	87
P8	FASTENER	87
P91	FASTENER	87
PC	PLASTIC HANDLE	359
PC20K	ADAPTOR (FOR WL-S1800)	450
PF	HOOK	221
PJ-60, 80, 100	SLIDE-IN TYPE CORNER CONNECTOR	23
PJ-60A, 80A, 100HA	DROP-IN TYPE CORNER CONNECTOR	22
PJ-60W, 80W	SLIDE-IN TYPE CORNER CONNECTOR	24
PL-100	OVERLAY DOOR PIVOT HINGE	309
PL-60	OVERLAY DOOR PIVOT HINGE	308
PL-65	OVERLAY DOOR PIVOT HINGE	307
PN-51	MINI DRAW LATCH	89
PP-60	INSET DOOR PIVOT HINGE	309
PR-20P	NON-MAGNETIC TOUCH LATCH	64
PR-21P	NON-MAGNETIC TOUCH LATCH	64
PR3PK	NON-MAGNETIC TOUCH LATCH	65
PR4PK	NON-MAGNETIC MINI TOUCH LATCH	65
PRS-40	PUSH BARREL BOLT	69
PS	DRAW LATCH	85
PS, P	DRAW LATCH	86
PS34A	CORNER FASTENER	84
PS35	DRAW LATCH	86
PT-148	TRUNK HANDLE	377
<b>R</b>		
R SERIES	CONCEALED HINGE	316
RB-102	DOUBLE HOOK	225
RC6900, RC6901	ROTARY CATCH	60
RCU	ROTARY CATCH(MORTISE TYPE)	60
RD	PULL	384
RF-50	ROTATING HOOK	231
RF-D35	HOOK	229
RF-U50	ROTATING / SWING HOOK	231
RH-760	LARGE HANDLE	341
RI-074	DOUBLE HOOK	225
RK-50	CONCEALED HINGE	316
RKA5	DRAWER RUNNER	183
RN-50	HOOK	225
RP	LEVELING GLIDE	433
RS-38	KNOB	382
RSS	KNOB	382
<b>S</b>		
S-100T30	TORQUE LID STAY (FREE STOP)	141
S-20	LID STAY (W/CATCH)	152



Item Name	Description	Page
S-21	LID STAY (W/CATCH)	152
S-23	LID STAY (W/CATCH)	152
S-52T15	TORQUE LID STAY (FREE STOP)	141
S-6166-2	LIFT-OFF HINGE (WELD-ON)	292
S-6166-6	LIFT-OFF HINGE (WELD-ON)	292
S-6173-2	LIFT-OFF HINGE	293
S-6173-5	LIFT-OFF HINGE	293
S-91, 92, 93	LID STAY	150
S-AT	HEAVY DUTY SPRING LOADED LID STAY	139
S-YT	SPRING LOADED LID STAY	138
S100-50	CABLE GROMMET	458
S1015-51	CABLE GROMMET	457
S165-76	CABLE GROMMET	457
S445, S51, S60, S76, S89	CABLE GROMMET	454
S93-35	CABLE GROMMET	456
SA	SPRING HINGE	296
SA-D	VENTILATOR	460
SA-M	VENTILATOR	459
SAD-160	DOOR STOPPER LID STAY	150
SB11A-AA-1	MAGNETIC CATCH	44
SB11B-AA-1	MAGNETIC CATCH	44
SBR40	BUTT HINGE	273
SCC-30	COMPRESSION DRAW LATCH	83
SCC-40	COMPRESSION DRAW LATCH	83
SCC-60	COMPRESSION DRAW LATCH	83
SCCA-40	COMPRESSION DRAW LATCH	84
SCCA-60	COMPRESSION DRAW LATCH	84
SD	PULL	383
SD-160	RECESSED PULL	368
SDS-100-TV/TVZ	SOFT-DOWN STAY (SHORT-ARM)	115
SDS-400-W	SOFT-DOWN STAY	117
SDS-50G	SDS FACE PLATE	119
SDS-C100	SOFT-DOWN STAY	116
SDS-C301N	SOFT-DOWN STAY	118
SFTH	STAINLESS STEEL TORQUE HINGE	321
SG	SYSTEM FOOT	436
SGH-200	HANDLE	357
SH	BUTT HINGE (W/SPRING)	297
SI2520	CABLE GROMMET	457
SK-T-ZA	TORQUE HINGE	325
SKH	LIFT-OFF HINGE	291
SL	CABLE GROMMET	454
SL-T	LED SLIM LIGHT	465
SL-WPG	LED Tough Light	463
SL-WPG	LED Tough Light	464
SLD	SWING DOWN STAY	135
SLS-ELAN	EASY LIFT-UP STAY	110
SLU-ELAN	SWING LIFT-UP STAY	134
SLUN-N	VERTICAL SWING LIFT-UP MECHANISH	133
SM	SHELF STANDARD	246
SMB-15R	SHELF SUPPORT	246
SMC	MAGNETIC CATCH (W/SWITCH)	54
SMH	RECESSED PULL	373

Item Name	Description	Page
SN	PULL	381
SN-711-8	SHEET METAL CAM LOCK	443
SND	PULL	381
SNR65	LIFT-OFF HINGE	290
SNRK65	LIFT-OFF HINGE	290
SNS27D	FULL EXTENSION SLIDE	170
SNS27S	3/4 EXTENCION SLIDE	177
SNS35D	FULL EXTENSION	169
SNS35S	3/4 EXTENCION SLIDE	176
SNS35W	FULL EXTENSION	168
SOR	LARGE HANDLE	341
SP	SHELF STANDARD	244
SP	RECESSED PULL	369
SP-18E	END CAP	242
SP-35	SHELF HOOK	244
SP0207	COUNTER PLATE	51
SPB-15R	SHELF SUPPORT	244
SPB-20	SHELF SUPPORT	245
SPE	SHELF STANDARD	247
SPE-FB20	SHELF SUPPORT	247
SPE-FC20	LEVELING CAP	247
SPF-20	SHELF SUPPORT	245
SPF-20A	SHELF HOLDER	245
SPF-20LC	LEVELING CAP	245
SPH	SHELF STANDARD	242
SPH-15	SHELF SUPPORT	243
SPH-20	SHELF SUPPORT	243
SPH-5	SHELF SUPPORT (W/HOLDER)	243
SPHL-1820	HEAVY DUTY SHELF STANDARD	241
SPHL-25	HEAVY DUTY SHELF SUPPORT	241
SPHL-30	SHELF SUPPORT	241
SPM-20B	SHELF SUPPORT	246
SPN-15	SHELF SUPPORT	248
SPN-17EC	END CAP	248
SPN-1820	NARROW SHELF STANDARD	248
SR40/SR50	BUTT HINGE	273
SR75/SR75B	BUTT HINGE	273
SRT	KNURLED KNOB	385
SRT-N	KNURLED KNOB	385
SSG	GATE LATCH	74
SSH	LARGE HANDLE	340
SSL	BAR LATCH	76
ST	CABLE GROMMET	455
ST-80, 100	HATCH PULL	379
ST-90, 115	HATCH PULL	379
STBRC	STAINLESS STEEL ROLLER CATCH	63
STF-A56AH, AC	CORNER FASTENER	82
STF-C64A, B	CORNER FASTENER (W/LOCK)	81
STF-CV150	DRAW LATCH (CLEAN ROOM)	80
STF100	DRAW LATCH (W/SAFETY LOCK)	78
STF40	DRAW LATCH	79
STF80	DRAW LATCH (SPRING LOADED)	79
STF82L	DRAW LATCH (W/SAFETY LOCK)	78
STH-C64	CORNER FASTENER HINGE (W/LOCK)	82



Item Name	Description	Page
SU	ANGLE BRACKET	240
SU-A	ANGLE BRACKET	239
SU-B	ANGLE BRACKET	240
SUS-E	STAINLESS STEEL CASTER (PLATE TYPE)	406
SUS-ER	STAINLESS STEEL CASTER (PLATE TYPE)	406
SUS-ET	STAINLESS STEEL CASTER (THREADED BOLT TYPE)	407
SUS-SJ	STAINLESS STEEL CASTER (PLATE TYPE)	404
SUS-SK	STAINLESS STEEL CASTER (PLATE TYPE)	405
SV	ANGLE BRACKET	240
SWF	WIRE PULL	351
SWP	WIRE PULL	351
SX-48	QUICK RELEASE LATCH	98
SYR140	BUTT HINGE	271
<b>T</b>		
T, TSD	CASTER (PLATE TYPE)	413
T, TSD	CASTER (THREADED BOLT TYPE)	413
TA3	HOOK	223
TC-42	MAGNETIC CATCH	49
TF	WIRE HOOK	220
TF40C	HEAVY DUTY COUNTERPLATE	80
TG	LEVELING GLIDE	436
THF-100	DRAW LATCH (W/HANDLE)	88
THF-75	DRAW LATCH	88
TK	SWING HOOK	228
TL	WIRE HOOK	220
TMU-115	TRUNK HANDLE	377
TN-S	LEVELING GLIDE	432
TO	FOLDING RING PULL (SPRING LOADED)	378
TP-LF, TPAH-LF	SHOCK-ABSORBING CASTER(PLATE TYPE)	392
TP-LC, TPAH-LC	SHOCK-ABSORBING CASTER(PLATE TYPE)	393
TSG	HEAVY DUTY CASTER (PLATE TYPE)	403
TSG, TSGS	WHEEL CASTER (PLATE TYPE)	408
TSR	HEAVY DUTY CASTER (PLATE TYPE)	403
TSR	WHEEL CASTER (PLATE TYPE)	408
TSS3	FULL EXTENSION SLIDE	166
TSSL	LINEAR BALL BEARING GUIDE	181
TY	WIRE HOOK	220
TZ-360	BUTTERFLY HOOK	228
<b>U</b>		
U-3005	MULTI-ANGLE LID STAY	149
U-3031	MULTI-ANGLE LID STAY	149
UC	SWING HOOK	230
UDD	DISK DAMPER	254
UDH	TORQUE DAMPER	255
UDH-16N	TORQUE DAMPER	256
UDH-16S	TORQUE DAMPER	258
UDH14	TORQUE DAMPER	259
UDH16	TORQUE DAMPER	257
UHG	LOW PROFILE HEAVY DUTY CASTER	400
UH GK	LOW PROFILE HEAVY DUTY CASTER	401
UJ	SWING HOOK	230
US	HANDLE	348
UT	RECESSED PULL	368

Item Name	Description	Page
UTZ-130	RECESSED PULL	368
<b>V</b>		
V2000	CABLE GROMMET	457
V60, V80	CABLE GROMMET	455
<b>W</b>		
W SERIES	COUNTERPLATE	51
WB-130357, WB-902357	HANDLE	348
WB-900404, WB900405	HANDLE	349
WB-900418, WB-900408	FLUSH SLAM LATCH	95
WB-901145	HOOK	234
WB-901146	HOOK	234
WB-901225	HANDLE	349
WB-901228	HANDLE	378
WB-901389	RECESSED PULL	364
WB-901390	RECESSED PULL	371
WB-901503, WB-901504	FOLDING HANDLE LATCH	96
WB-901551, WB-901552	FOLDING HANDLE LATCH	96
WB-901790	HANDLE	349
WH	LATCH HOOK	226
WL-N1800	NOTEBOOK LOCK	449
WL-P1800	NOTEBOOK LOCK	449
WL-S1800	NOTEBOOK LOCK	450
WP	OVERLAY DOOR PIVOT HINGE	308
<b>X</b>		
XL-CU	HANDLE	352
XL-CUF	LARGE UTILITY HOOK	216
XL-CUJ	LARGE UTILITY HOOK	219
XL-CUR	HANDLE	353
XL-CUY	HANDLE	345
XL-GH01-250	GLASS DOOR HINGE	302
XL-GH01-600	GLASS DOOR HINGE	302
XL-GH03-48-0	INSET GLASS DOOR HINGE	301
XL-GH03-48-8	HALF OVERLAY GLASS DOOR HINGE	301
XL-JS	HANDLE	352
XL-JSF40TT	SWING HOOK	230
XL-JSR	HANDLE	352
XL-SA01	ANGLE BRACKET	239
XL-SB210	LARGE UTILITY HOOK	218
XL-SF115	LARGE UTILITY HOOK	218
XLA-HA	HANDLE	355
XLA-HHA	RECESSED PULL	369
<b>Y</b>		
YA-0812, 1216	DOOR HOLDER	155
YA-2020	DOOR HOLDER	154
YF	FOOT STAYS	153
YF-300W	FOOT STAYS	153
YHS	BUTT HINGE	279
YK-70	RECESSED PULL	372
YK-W100	RECESSED PULL	372
YS-P05	SPACER	51



## Inch to Metric Conversion table

	1"	2"	3"	4"	5"	6"	7"	8"	9"	10"	11"	12"	
0/0	0.0	25.4	50.8	76.2	101.6	127.0	152.4	177.8	203.2	228.6	254.0	279.4	304.8
1/64	0.4	25.8	51.2	76.6	102.0	127.4	152.8	178.2	203.6	229.0	254.4	279.8	305.2
1/32	0.8	26.2	51.6	77.0	102.4	127.8	153.2	178.6	204.0	229.4	254.8	280.2	305.6
3/64	1.2	26.6	52.0	77.4	102.8	128.2	153.6	179.0	204.4	229.8	255.2	280.6	306.0
1/16	1.6	27.0	52.4	77.8	103.2	128.6	154.0	179.4	204.8	230.2	255.6	281.0	306.4
5/64	2.0	27.4	52.8	78.2	103.6	129.0	154.4	179.8	205.2	230.6	256.0	281.4	306.8
3/32	2.4	27.8	53.2	78.6	104.0	129.4	154.8	180.2	205.6	231.0	256.4	281.8	307.2
7/64	2.8	28.2	53.6	79.0	104.4	129.8	155.2	180.6	206.0	231.4	256.8	282.2	307.6
1/8	3.2	28.6	54.0	79.4	104.8	130.2	155.6	181.0	206.4	231.8	257.2	282.6	308.0
9/64	3.6	29.0	54.4	79.8	105.2	130.6	156.0	181.4	206.8	232.2	257.6	283.0	308.4
5/32	4.0	29.4	54.8	80.2	105.6	131.0	156.4	181.8	207.2	232.6	258.0	283.4	308.8
11/64	4.4	29.8	55.2	80.6	106.0	131.4	156.8	182.2	207.6	233.0	258.4	283.8	309.2
3/16	4.8	30.2	55.6	81.0	106.4	131.8	157.2	182.6	208.0	233.4	258.8	284.2	309.6
13/64	5.2	30.6	56.0	81.4	106.8	132.2	157.6	183.0	208.4	233.8	259.2	284.6	310.0
7/32	5.6	31.0	56.4	81.8	107.2	132.6	158.0	183.4	208.8	234.2	259.6	285.0	310.4
15/64	6.0	31.4	56.8	82.2	107.6	133.0	158.4	183.8	209.2	234.6	260.0	285.4	310.8
1/4	6.4	31.8	57.2	82.5	108.0	133.4	158.8	184.2	209.6	235.0	260.4	285.8	311.2
17/64	6.7	32.1	57.5	82.9	108.3	133.7	159.1	184.5	209.9	235.3	260.7	286.1	311.5
9/32	7.1	32.5	57.9	83.3	108.7	134.1	159.5	184.9	210.3	235.7	261.1	286.5	311.9
19/64	7.5	32.9	58.3	83.7	109.1	134.5	159.9	185.3	210.7	236.1	261.5	286.9	312.3
5/16	7.9	33.3	58.7	84.1	109.5	134.9	160.3	185.7	211.1	236.5	261.9	287.3	312.7
21/64	8.3	33.7	59.1	84.5	109.9	135.3	160.7	186.1	211.5	236.9	262.3	287.7	313.1
11/32	8.7	34.1	59.5	84.9	110.3	135.7	161.1	186.5	211.9	237.3	262.7	288.1	313.5
23/64	9.1	34.5	59.9	85.3	110.7	136.1	161.5	186.9	212.3	237.7	263.1	288.5	313.9
3/8	9.5	34.9	60.3	85.7	111.1	136.5	161.9	187.3	212.7	238.1	263.5	288.9	314.3
25/64	9.9	35.3	60.7	86.1	111.5	136.9	162.3	187.7	213.1	238.5	263.9	289.3	314.7
13/32	10.3	35.7	61.1	86.5	111.9	137.3	162.7	188.1	213.5	238.9	264.3	289.7	315.1
27/64	10.7	36.1	61.5	86.9	112.3	137.7	163.1	188.5	213.9	239.3	264.7	290.1	315.5
7/16	11.1	36.5	61.9	87.3	112.7	138.1	163.5	188.9	214.3	239.7	265.1	290.5	315.9
29/64	11.5	36.9	62.3	87.7	113.1	138.5	163.9	189.3	214.7	240.1	265.5	290.9	316.3
15/32	11.9	37.3	62.7	88.1	113.5	138.9	164.3	189.7	215.1	240.5	265.9	291.3	316.7
31/64	12.3	37.7	63.1	88.5	113.9	139.3	164.7	190.1	215.5	240.9	266.3	291.7	317.1
1/2	12.7	38.1	63.5	88.9	114.3	139.7	165.1	190.5	215.9	241.3	266.7	292.1	317.5
33/64	13.1	38.5	63.9	89.3	114.7	140.1	165.5	190.9	216.3	241.7	267.1	292.5	317.9
17/32	13.5	38.9	64.3	89.7	115.1	140.5	165.9	191.3	216.7	242.1	267.5	292.9	318.3
35/64	13.9	39.3	64.7	90.1	115.5	140.9	166.3	191.7	217.1	242.5	267.9	293.3	318.7
9/16	14.3	39.7	65.1	90.5	115.9	141.3	166.7	192.1	217.5	242.9	268.3	293.7	319.1
37/64	14.7	40.1	65.5	90.9	116.3	141.7	167.1	192.5	217.9	243.3	268.7	294.1	319.5
19/32	15.1	40.5	65.9	91.3	116.7	142.1	167.5	192.9	218.3	243.7	269.1	294.5	319.9
39/64	15.5	40.9	66.3	91.7	117.1	142.5	167.9	193.3	218.7	244.1	269.5	294.9	320.3
5/8	15.9	41.3	66.7	92.1	117.5	142.9	168.3	193.7	219.1	244.5	269.9	295.3	320.7
41/64	16.3	41.7	67.1	92.5	117.9	143.3	168.7	194.1	219.5	244.9	270.3	295.7	321.1
21/32	16.7	42.1	67.5	92.9	118.3	143.7	169.1	194.5	219.9	245.3	270.7	296.1	321.5
43/64	17.1	42.5	67.9	93.3	118.7	144.1	169.5	194.9	220.3	245.7	271.1	296.5	321.9
11/16	17.5	42.9	68.3	93.7	119.1	144.5	169.9	195.3	220.7	246.1	271.5	296.9	322.3
45/64	17.9	43.3	68.7	94.1	119.5	144.9	170.3	195.7	221.1	246.5	271.9	297.3	322.7
23/32	18.3	43.7	69.1	94.5	119.9	145.3	170.7	196.1	221.5	246.9	272.3	297.7	323.1
47/64	18.7	44.1	69.5	94.9	120.3	145.7	171.1	196.5	221.9	247.3	272.7	298.1	323.5
3/4	19.1	44.5	69.9	95.2	120.7	146.1	171.5	196.9	222.3	247.7	273.1	298.5	323.9
49/64	19.4	44.8	70.2	95.6	121.0	146.4	171.8	197.2	222.6	248.0	273.4	298.8	324.2
25/32	19.8	45.2	70.6	96.0	121.4	146.8	172.2	197.6	223.0	248.4	273.8	299.2	324.6
51/64	20.2	45.6	71.0	96.4	121.8	147.2	172.6	198.0	223.4	248.8	274.2	299.6	325.0
13/16	20.6	46.0	71.4	96.8	122.2	147.6	173.0	198.4	223.8	249.2	274.6	300.0	325.4
53/64	21.0	46.4	71.8	97.2	122.6	148.0	173.4	198.8	224.2	249.6	275.0	300.4	325.8
27/32	21.4	46.8	72.2	97.6	123.0	148.4	173.8	199.2	224.6	250.0	275.4	300.8	326.2
55/64	21.8	47.2	72.6	98.0	123.4	148.8	174.2	199.6	225.0	250.4	275.8	301.2	326.6
7/8	22.2	47.6	73.0	98.4	123.8	149.2	174.6	200.0	225.4	250.8	276.2	301.6	327.0
57/64	22.6	48.0	73.4	98.8	124.2	149.6	175.0	200.4	225.8	251.2	276.6	302.0	327.4
29/32	23.0	48.4	73.8	99.2	124.6	150.0	175.4	200.8	226.2	251.6	277.0	302.4	327.8
59/64	23.4	48.8	74.2	99.6	125.0	150.4	175.8	201.2	226.6	252.0	277.4	302.8	328.2
15/16	23.8	49.2	74.6	100.0	125.4	150.8	176.2	201.6	227.0	252.4	277.8	303.2	328.6
61/64	24.2	49.6	75.0	100.4	125.8	151.2	176.6	202.0	227.4	252.8	278.2	303.6	329.0
31/32	24.6	50.0	75.4	100.8	126.2	151.6	177.0	202.4	227.8	253.2	278.6	304.0	329.4
63/64	25.0	50.4	75.8	101.2	126.6	152.0	177.4	202.8	228.2	253.6	279.0	304.4	329.8

## Metric to Inch Conversion

mm	Inches
0.1	0.0039
0.2	0.0079
0.3	0.0118
0.4	0.0157
0.5	0.0197
0.6	0.0236
0.7	0.0276
0.8	0.0315
0.9	0.0354
1	0.0394
2	0.0787
3	0.1181
4	0.1575
5	0.1969
6	0.2362
7	0.2756
8	0.3150
9	0.3543
10	0.3937
11	0.4331
12	0.4724
13	0.5118
14	0.5512
15	0.5906
16	0.6299
17	0.6693
18	0.7087
19	0.7480
20	0.7874
21	0.8268
22	0.8661
23	0.9055
24	0.9449
25	0.9843
26	1.0236
27	1.0630
28	1.1024
29	1.1417
30	1.1811
31	1.2205
32	1.2598
33	1.2992
34	1.3386
35	1.3780
36	1.4173
37	1.4567
38	1.4961
39	1.5354
40	1.5748
41	1.6142
42	1.6535
43	1.6929
44	1.7323
45	1.7717
46	1.8110
47	1.8504
48	1.8898
49	1.9291
50	1.9685
51	2.0079
52	2.0472
53	2.0866
54	2.1260
55	2.1654



[Inch]

# Measurement Conversions

## LENGTH

cm	mm	inch	feet
1	10	0.394	0.0328
0.1	1	0.0394	0.00328
2.54	25.4	1	0.083
30.48	304.8	12	1

inch = mm ÷ 25.4

mm = inch x 25.4

## WEIGHT

g	kg	oz	lb
1	0.001	0.0353	0.0022
1000	1	35.27	2.205
28.4	0.0284	1	0.0625
453.6	0.454	16	1

lb = kg x 2.205

kg = lb ÷ 2.205

## FORCE

N	kgf	lbf
1	0.10197	0.225
9.807	1	2.205
4.448	0.454	1

lbf = kgf x 2.205      N = kgf x 9.807

kgf = lbf ÷ 2.205      kgf = N ÷ 9.807

## MOMENT

N • m	kgf • cm	lbs • in
1	10.197	8.85
0.0981	1	0.868
0.113	1.152	1

lbs • in = kgf • cm x 0.868      N • m = kgf • cm x 0.0981

kgf • cm = lbs • in ÷ 0.868      kgf • cm = N • m ÷ 0.0981

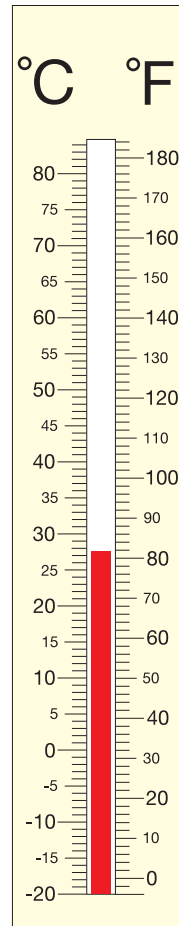

## TEMPERATURE

°C	°F
0	32
-17.77	0

°C = (°F - 32) x 5 ÷ 9

°F = °C ÷ 5 x 9 + 32

\*All tools and figures are for reference only.

[Metric]



# LAMP®

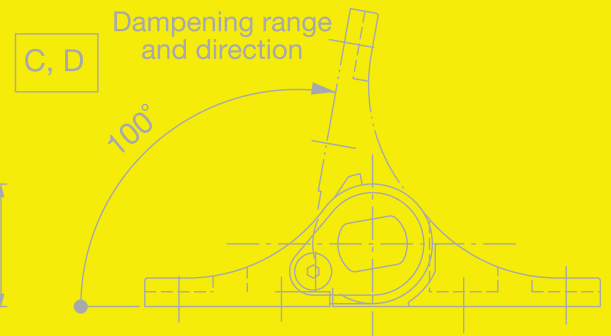
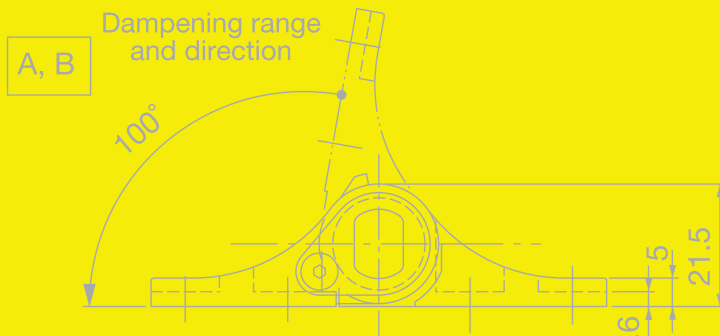
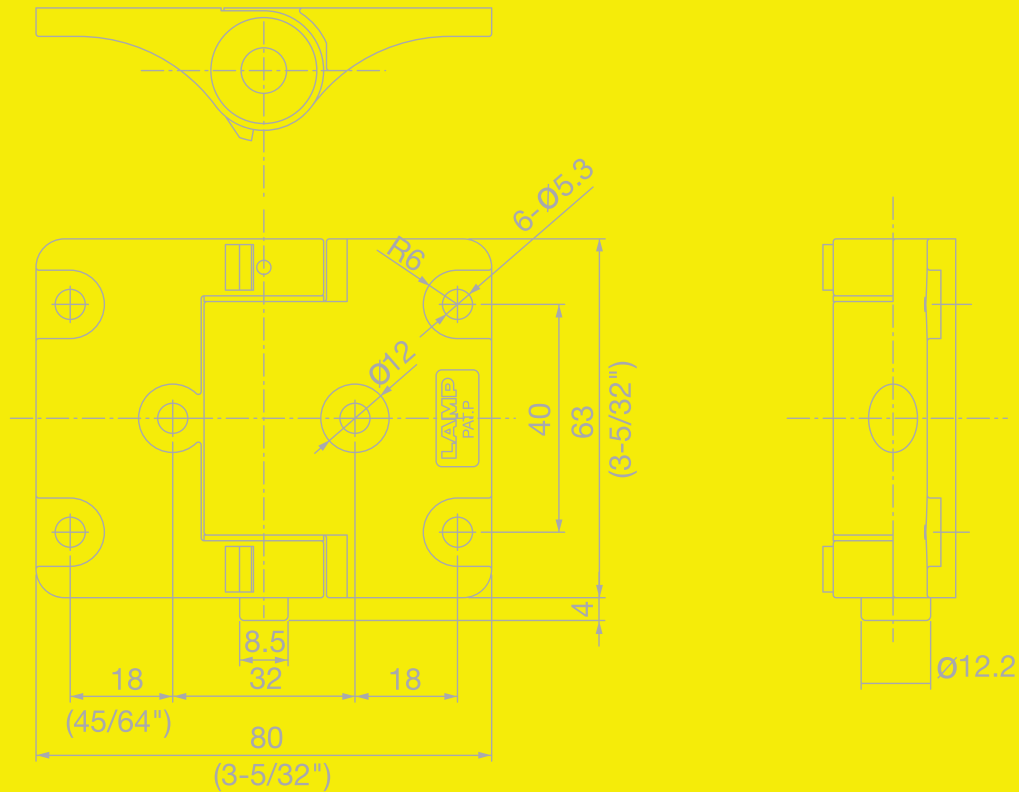

Providing solutions since 1930.



**GLOBAL HEADQUARTERS:**

**SUGATSUNE KOGYO CO.,LTD.**

Tokyo JAPAN

E-mail : [export@sugatsune.co.jp](mailto:export@sugatsune.co.jp)

[www.sugatsune-intl.com](http://www.sugatsune-intl.com)

**UK BRANCH:**

**SUGATSUNE KOGYO (UK) LTD.**

Reading UK

E-mail : [sales@sugatsune.co.uk](mailto:sales@sugatsune.co.uk)

[www.sugatsune.co.uk](http://www.sugatsune.co.uk)