

simply
practical

FATH[®]

Components



Bodenelemente 1
Floor Elements

Scharniere 2
Hinges

Nutmuttern und -schrauben 3
T-Nuts and T-Bolts

Verbindungstechnik 4
Connecting Systems

Griffe und Verschlüsse 5
Handles and Latches

Arbeitsplatzkomponenten 6
Components for Work Stations

Gleiter und Rollen 7
Sliders and Rollers

Fördertechnik 8
Conveyors

Schutz- und Trennwandelemente 9
Enclosures, Guards, Partitions

Flächenbefestigungen 10
Panel Fasteners

Abdeckelemente 11
Cover Elements

Kabelführungen 12
Cable Management

Diverse Komponenten 13
Miscellaneous Components

Rundrohrkomponenten 14
Tubular Frame Components



MASCHINENBAUKOMPONENTEN
FATH *ENGINEERING COMPONENTS*
VERSION 18.1

Informationen *Information*
über diesen Katalog *About this Catalog*

INHALTSÜBERSICHT *CONTENT OVERVIEW*





11 - 130
Bodenelemente
Floor Elements 1



135 - 229
Scharniere
Hinges 2



235 - 311
Nutmuttern und -schrauben
T-Nuts and T-Bolts 3



321 - 522
Verbindungstechnik
Connecting Systems 4



527 - 561
Griffe und Verschlüsse
Handles and Latches 5



565 - 580
Arbeitsplatzkomponenten
Components for Work Stations 6



583 - 606
Gleiter und Rollen
Sliders and Rollers 7



611 - 656
Fördertechnik
Conveyors 8



659 - 667
Schutz- und Trennwandelemente
Enclosures, Guards, Partitions 9



673 - 716
Flächenbefestigungen
Panel Fasteners 10



719 - 744
Abdeckelemente
Cover Elements 11



747 - 754
Kabelführungen
Cable Management 12



757 - 763
Diverse Komponenten
Miscellaneous Components 13



767 - 787
Rundrohrkomponenten
Tubular Frame Components 14



KUNDENINDIVIDUELLE KOMponentEN VON FATH

CUSTOMIZED COMPONENTS MADE BY FATH

Beispiel: Clip-Kabelbinder

Example: Clip Cable Binder

Variante 1

Der Kabelbinder wird im Markt eingeführt mit einer Bohrung zur Befestigung mittels Schraube und Nutenstein. So lässt er sich sowohl auf Flächenelementen als auch – mit dem passenden Nutenstein – an allen Profilsystemen einsetzen.

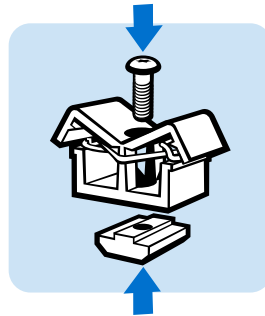

Option 1

The Clip Cable Binder is introduced into the market with a plain bore to allow fixation to the profile with a screw and a T-slot nut. That way it can be used both on ordinary panels (wood, Perspex or other) and on any Aluminum profile system.

Variante 2

Kurz danach stellen wir den Kabelbinder mit einem Hammer vor, der in viele der gängigen Profile passt. Die Montage wird durch den Hammer erheblich vereinfacht, Schraube und Nutenstein sind nicht mehr nötig. Zahlreiche Nutzer von Aluprofil-Systemen können das Teil kostengünstig einsetzen.

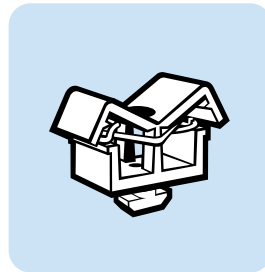

Option 2

Shortly afterwards we launch the Clip Cable Binder with a hammer that fits in the most commonly used profiles. Assembly of the Clip Cable Binder to the profile is considerably easier that way as no screw or T-slot nut are required. Thus, numerous users of aluminum profiles are able to use this part cost effectively.

Variante 3

Für Kunden die das wünschen passen wir, ab einer gewissen Stückzahl, den Hammer an deren spezielles Profil an. Sie nehmen das Teil in ihren Katalog auf und verdienen am Weiterverkauf.

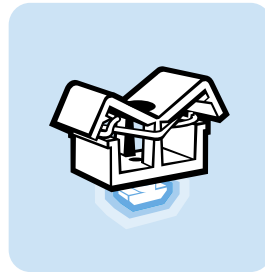

Option 3

For customers wishing so we can modify the hammer to suit their individual profile. That way they can include it in their catalogue and make a profit on the resale.

Auf Wunsch machen wir Ihnen gerne ein Angebot zur Anpassung unseres Zubehör-Programms an Ihr Profil. Sprechen Sie mit uns:
Telefon: +49 (0) 9175 7909-200
E-mail: sales@fath.net



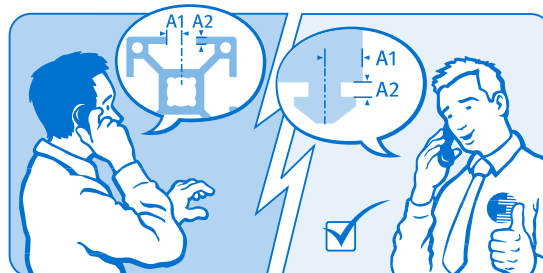



































We will gladly quote you for customizing our accessories program to your profile. Give us a call today.
Phone: +49 (0) 9175 7909-200 (Europe)
Phone: 407-601-5900 (USA)
E-mail: sales@fath.net









































INHALTSÜBERSICHT *CONTENT OVERVIEW*



Bodenelemente <i>Floor Elements</i>	1
Scharniere <i>Hinges</i>	2
Nutmuttern und -schrauben <i>T-Nuts and T-Bolts</i>	3
Verbindungstechnik <i>Connecting Systems</i>	4
Griffe und Verschlüsse <i>Handles and Latches</i>	5
Arbeitsplatzkomponenten <i>Components for Work Stations</i>	6
Gleiter und Rollen <i>Sliders and Rollers</i>	7
Fördertechnik <i>Conveyors</i>	8
Schutz- und Trennwandelemente <i>Enclosures, Guards, Partitions</i>	9
Flächenbefestigungen <i>Panel Fasteners</i>	10
Abdeckelemente <i>Cover Elements</i>	11
Kabelführungen <i>Cable Management</i>	12
Diverse Komponenten <i>Miscellaneous Components</i>	13
Rundrohrkomponenten <i>Tubular Frame Components</i>	14

































	Teller für Gelenkstellfüße, Kugel 10	<i>Base for Swivel Feet, Ball Joint 10</i>	13		Gewindestange für Gelenkstellfüße, Kugel 15	<i>Threaded Rod for Swivel Feet, Ball Joint 15</i>	32
	Gewindestange für Gelenkstellfüße, Kugel 10	<i>Threaded Rod for Swivel Feet, Ball Joint 10</i>	14		UNC-Gewindestange für Gelenkstellfüße, Kugel 15	<i>UNC Threaded Rod for Swivel Feet, Ball Joint 15</i>	33
	Anti-Slip-Platte	<i>Anti-slip Plate</i>	15		UNC-Gewindestange für Gelenkstellfüße, Kugel 15	<i>UNC Threaded Rod for Swivel Feet, Ball Joint 15</i>	34
	Teller für Gelenkstellfüße, Kugel 15	<i>Base for Swivel Feet, Ball Joint 15</i>	16		Kugelpopf mit Innengewinde, Kugel 15	<i>Ball Joint with Female Thread, Ball Joint 15</i>	35
	Teller für Gelenkstellfüße, Kugel 15	<i>Base for Swivel Feet, Ball Joint 15</i>	17		Teller für Gelenkstellfüße, Kugel 22	<i>Base for Swivel Feet, Ball Joint 22</i>	36
	Teller für Gelenkstellfüße, Kugel 15	<i>Base for Swivel Feet, Ball Joint 15</i>	18		Teller für Gelenkstellfüße, Kugel 22	<i>Base for Swivel Feet, Ball Joint 22</i>	37
	Teller für Gelenkstellfüße, Kugel 15	<i>Base for Swivel Feet, Ball Joint 15</i>	19		Teller für Gelenk-Schwerlastfüße, Kugel 22	<i>Base for Heavy-duty Swivel Feet, Ball Joint 22</i>	38
	Teller für Gelenkstellfüße, Kugel 15	<i>Base for Swivel Feet, Ball Joint 15</i>	20		Gewindestange für Gelenkstellfüße, Kugel 22	<i>Threaded Rod for Swivel Feet, Ball Joint 22</i>	39
	Teller für Gelenkstellfüße, Kugel 15	<i>Base for Swivel Feet, Ball Joint 15</i>	21		Gewindestange für Gelenkstellfüße, Kugel 22	<i>Threaded Rod for Swivel Feet, Ball Joint 22</i>	40
	Teller für Integral-Stellfüße, Kugel 15	<i>Base for Sealed Leveling Feet, Ball Joint 15</i>	22		Anti-Slip-Platte	<i>Anti-slip Plate</i>	41
	Teller 40 mit Ausleger für Gelenkstellfüße, Kugel 15	<i>Extended Base 40 for Swivel Feet, Ball Joint 15</i>	23		Anti-Slip-Platte	<i>Anti-slip Plate</i>	42
	Teller 60 mit Ausleger für Gelenkstellfüße, Kugel 15	<i>Extended Base 60 for Swivel Feet, Ball Joint 15</i>	24		Anti-Slip-Platte	<i>Anti-slip Plate</i>	43
	Teller 80 mit Ausleger für Gelenkstellfüße, Kugel 15	<i>Extended Base 80 for Swivel Feet, Ball Joint 15</i>	25		Anti-Slip-Platte	<i>Anti-slip Plate</i>	44
	Teller 80 mit Ausleger für Gelenkstellfüße, Kugel 15	<i>Extended Base 80 for Swivel Feet, Ball Joint 15</i>	26		Teller für feste Stellfüße	<i>Base for Pivot Feet</i>	45
	Trapezteller für Gelenkstellfüße, Kugel 15	<i>Trapezoid Base for Swivel Feet, Ball Joint 15</i>	27		Teller für feste Stellfüße	<i>Base for Pivot Feet</i>	46
	Quadratteller für Gelenkstellfüße, Kugel 15	<i>Square Base for Swivel Feet, Ball Joint 15</i>	28		Teller für feste Stellfüße	<i>Base for Pivot Feet</i>	47
	Gewindestange für Gelenkstellfüße, Kugel 15	<i>Threaded Rod for Swivel Feet, Ball Joint 15</i>	29		Teller für feste Stellfüße	<i>Base for Pivot Feet</i>	48
	Gewindestange für Gelenkstellfüße, Kugel 15	<i>Threaded Rod for Swivel Feet, Ball Joint 15</i>	30		Teller für feste Stellfüße	<i>Base for Pivot Feet</i>	49
	Gewindestange für Gelenkstellfüße, Kugel 15	<i>Threaded Rod for Swivel Feet, Ball Joint 15</i>	31		Teller für feste Stellfüße	<i>Base for Pivot Feet</i>	50







	Trapezteller für feste Stellfüße	<i>Trapezoid Base for Pivot Feet</i>	51		Anti-Slip-Platte	<i>Anti-slip Plate</i>	70
	Teller 80 mit Ausleger für feste Stellfüße	<i>Extended Base 80 for Pivot Feet</i>	52		Teller für starre Schwerlastfüße	<i>Base for Heavy-duty Fixed Feet</i>	71
	Quadratteller für feste Stellfüße	<i>Square Base for Pivot Feet</i>	53		Gewindestange für starre Schwerlastfüße	<i>Threaded Rod for Heavy-duty Fixed Feet</i>	72
	Teller für feste Schwerlastfüße	<i>Base for Heavy-duty Pivot Feet</i>	54		Gewindestange für starre Schwerlastfüße	<i>Threaded Rod for Heavy-duty Fixed Feet</i>	73
	Bodenbefestigung	<i>Floor Mounting</i>	55		Anti-Slip-Platte	<i>Anti-slip Plate</i>	74
	Gewindestange für feste Stellfüße	<i>Threaded Rod for Pivot Feet</i>	56		Teller für Entenfuß 16	<i>Base for Duck Foot 16</i>	75
	Gewindestange für feste Stellfüße	<i>Threaded Rod for Pivot Feet</i>	57		Teller für Entenfuß 20	<i>Base for Duck Foot 20</i>	76
	UNC-Gewindestange für feste Stellfüße	<i>UNC Threaded Rod for Pivot Feet</i>	58		Montagesatz für Enten-Stellfuß	<i>Assembling Set for Duck Foot</i>	77
	UNC-Gewindestange für feste Stellfüße	<i>UNC Threaded Rod for Pivot Feet</i>	59		Enten-Stellfuß	<i>Duck Foot</i>	78
	Anti-Slip-Platte	<i>Anti-slip Plate</i>	60		Enten-Stellfuß	<i>Duck Foot</i>	79
	Anti-Slip-Platte	<i>Anti-slip Plate</i>	61		Mutter DIN 439 für Gewindestange	<i>Nut DIN 439 for Threaded Rod</i>	80
	Anti-Slip-Platte	<i>Anti-slip Plate</i>	62		Mutter DIN 934 für Gewindestange	<i>Nut DIN 934 for Threaded Rod</i>	81
	Fester Stellfuß – Glocke	<i>Pivot Foot – Bell</i>	63		Hub-Schrauber	<i>Adjustable Leveling Foot</i>	82
	Anti-Slip-Platte	<i>Anti-slip Plate</i>	64		Gewindestopfen für Vierkantrohre	<i>Threaded Bush for Square Tubes</i>	83
	Teller für ECO-Stellfüße	<i>Base for ECO Feet</i>	65		Gewindestopfen für Vierkantrohre	<i>Threaded Bush for Square Tubes</i>	84
	Teller für ECO-Stellfüße	<i>Base for ECO Feet</i>	66		Gewindestopfen für Vierkantrohre	<i>Threaded Bush for Square Tubes</i>	85
	Teller für ECO-Stellfüße	<i>Base for ECO Feet</i>	67		Gewindestopfen für Vierkantrohre	<i>Threaded Bush for Square Tubes</i>	86
	Gewindestange für ECO-Stellfüße	<i>Threaded Rod for ECO Feet</i>	68		Gewindestopfen für rechteckige Vierkantrohre	<i>Threaded Bush for Rectangular Tubes</i>	87
	Gewindestange für ECO-Stellfüße	<i>Threaded Rod for ECO Feet</i>	69		Gewindestopfen für Rundrohr Ø 30	<i>Threaded Bush for Round Tubes Ø 30</i>	88

Bodenelemente *Floor Elements*

Inhaltsverzeichnis *Table of Content*



	Gewindestopfen für Rundrohr Ø 38	<i>Threaded Bush for Round Tubes Ø 38</i>	89		Bodenwinkel 140, 1 Nut	<i>Floor Bracket 140, 1 Slot Version</i>	107
	Gewindestopfen für Rundrohr Ø 42,4	<i>Threaded Bush for Round Tubes Ø 42.4</i>	90		Bodenwinkel 140, 2 Nuten	<i>Floor Bracket 140, 2 Slot Version</i>	108
	Gewindestopfen für Rundrohr Ø 48,3	<i>Threaded Bush for Round Tubes Ø 48.3</i>	91		Bodenwinkel 30	<i>Floor Bracket 30</i>	109
	Gewindestopfen für Rundrohr Ø 50,9	<i>Threaded Bush for Round Tubes Ø 50.9</i>	92		Bodenwinkel 45	<i>Floor Bracket 45</i>	110
	Gewindestopfen für Rundrohr Ø 60,3	<i>Threaded Bush for Round Tubes Ø 60.3</i>	93		Bodenwinkel 120	<i>Floor Bracket 120</i>	111
	Gewindehülse	<i>Threaded Sleeve</i>	94		Bodenwinkel 120, höhenverstellbar	<i>Adjustable Floor Bracket 120</i>	112
	Transport- und Fußplatte 40 x 80	<i>Transport and Base Plate 40 x 80</i>	95		Bodenwinkel 160	<i>Floor Bracket 160</i>	113
	Transport- und Fußplatte 80 x 80	<i>Transport and Base Plate 80 x 80</i>	96		Bodenwinkel 160, höhenverstellbar	<i>Adjustable Floor Bracket 160</i>	114
	Transport- und Fußplatte 20 x 40	<i>Transport and Base Plate 20 x 40</i>	97		Bodenwinkel 200	<i>Floor Bracket 200</i>	115
	Transport- und Fußplatte 40 x 40	<i>Transport and Base Plate 40 x 40</i>	98		Bodenwinkel 160	<i>Floor Bracket 160</i>	116
	Transport- und Fußplatte 30 x 60	<i>Transport and Base Plate 30 x 60</i>	99		Pfostenkonsole	<i>Floor Mount Base</i>	117
	Transport- und Fußplatte 60 x 60	<i>Transport and Base Plate 60 x 60</i>	100		Doppelnutenstein für Pfostenkonsole	<i>Double T-slot Nut for Floor Mount Base</i>	118
	Transport- und Fußplatte 40 x 80	<i>Transport and Base Plate 40 x 80</i>	101		Fußkonsole 45/60 - 120	<i>Foot Console 45/60 - 120</i>	119
	Transport- und Fußplatte 80 x 80	<i>Transport and Base Plate 80 x 80</i>	102		Fußkonsole 45/90 - 150	<i>Foot Console 45/90 - 150</i>	120
	Transport- und Fußplatte 45 x 90	<i>Transport and Base Plate 45 x 90</i>	103		Fußplatte 45 / 60 / 90 - 135	<i>Foot Plate 45 / 60 / 90 - 135</i>	121
	Transport- und Fußplatte 90 x 90	<i>Transport and Base Plate 90 x 90</i>	104				
	Transport- und Fußplatte 50 x 100	<i>Transport and Base Plate 50 x 100</i>	105				
	Transport- und Fußplatte 100 x 100	<i>Transport and Base Plate 100 x 100</i>	106				

	Lenkrolle	<i>Swivel Castor</i>	124
	Lenkrolle mit integrierter Anschraubplatte 40 / 45	<i>Swivel Castor with Mounting Plate 40 / 45</i>	125
	Bockrolle	<i>Fixed Castor</i>	126
	Bockrolle mit Anschraubplatte 38 - 1,5" / 40 / 45	<i>Fixed Castor with Mounting Plate 38 - 1,5" / 40 / 45</i>	127
	Set Hubrolle hydraulisch	<i>Set Hydraulic Lift Castor</i>	128
	Hubrolle elektrisch	<i>Electric Lift Castor</i>	129

STELLFÜSSE – DAS BAUKASTENSYSTEM

FATH Stellfüße finden Sie unter vielen Maschinen und Anlagen überall auf der Welt. Das hat gute Gründe, denn neben der Qualität zählt auch die Flexibilität – über 20.000 Variationsmöglichkeiten sind unsere Antwort darauf.

Ihr Stellfuß nach Maß

Stellen Sie sich Ihren maßgeschneiderten Stellfuß selbst zusammen: Fußteller auswählen – entscheiden, ob mit oder ohne Anti-Slip-Platte – Gewindestange auswählen – fertig.

Gerne liefern wir Ihnen Ihre Stellfüße nach Maß auch komplett montiert.

LEVELING FEET – THE MODULAR SYSTEM

FATH leveling feet can be found on many installations and machines around the world as they are not only of high quality, but also offer great flexibility: Thanks to our modular system, more than 20,000 variations are at your disposal.

Your made-to-measure leveling foot

Creating your own leveling foot is easy: choose a base, decide whether you want an anti-slip plate or not, add a threaded rod and your made-to-measure leveling foot is ready.

With pleasure we deliver your made-to-measure leveling feet fully assembled.

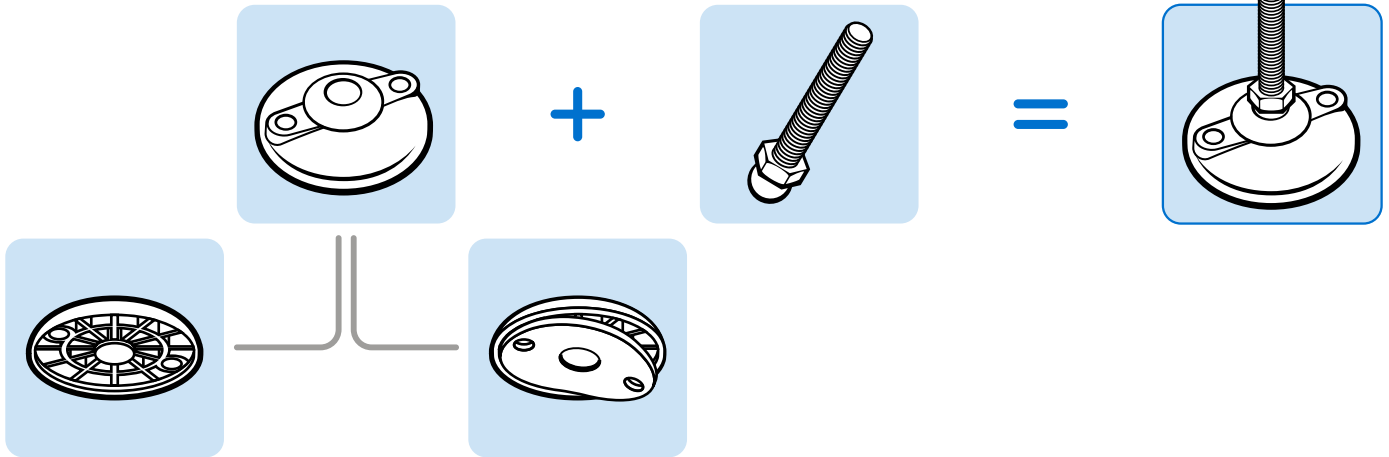

Edelstahl

Unser gesamtes Stellfuß-Programm ist auch in Volledelstahl erhältlich, zum Beispiel für den Einsatz in der Lebensmittel- oder chemischen Industrie. Diese Stellfüße sind nicht nur unempfindlich gegen viele Chemikalien und Umwelteinflüsse, sie bestechen auch durch ihre hochwertige Optik.



Stainless Steel

Our entire range of leveling feet is also available in stainless steel, making them suitable for use in the food and medical industry. These leveling feet are not just resistant against many chemicals and environmental influences, they also look spectacular because of the material used.



STELLFÜSSE – DAS BAUKASTENSYSTEM

Maßtoleranzen für Stellfüße

Folgende Maßtoleranzen gelten für die in diesem Katalog gezeigten Produkte als Standard. Sprechen Sie mit uns, wenn Sie in besonderen Fällen engere Toleranzen benötigen.

Gewindestangen

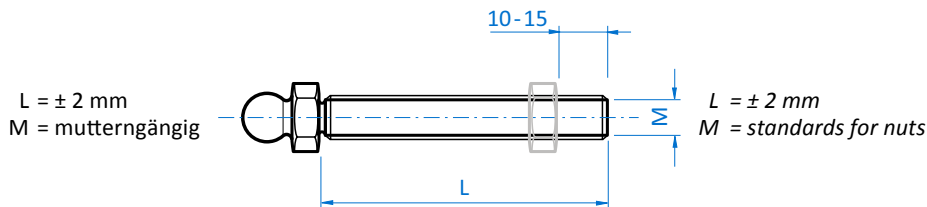

Threaded Rods

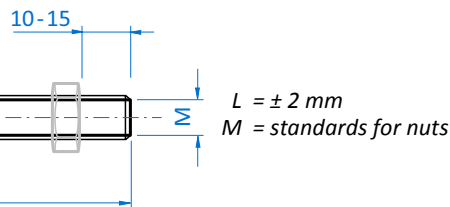

Fußteller

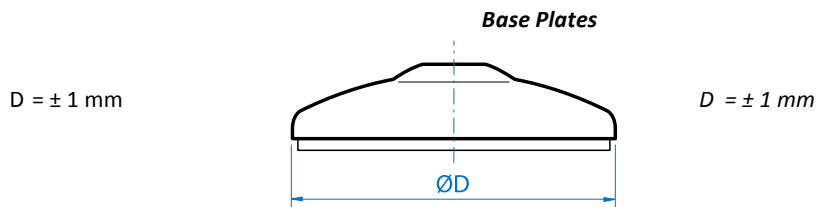

Base Plates

Belastungsprüfungen

FATH Stellfüße, Scharniere und Gewindestopfen wurden auf Belastung getestet. Folgende Testverfahren kamen zur Anwendung:

Stellfüße

Vertikale Belastung der Gewindestangen über eine handelsübliche Mutter. Nach einer Vorlast von ca. 1.500 N wurde die vertikale Last (lotrecht) langsam und stetig bis zu der Kraft gesteigert, die benötigt wurde, die komplette Einheit ca. $1,5 \pm 0,5 \text{ mm}$ zusammen zu drücken. Die Prüfungen wurden an je 3 Mustern durchgeführt. Die Teller wurden zur Prüfung auf Stahlplatten gestellt. Eine horizontale Kraft wurde nicht eingeleitet.

Stopfen

Vertikale Belastung der Stopfen und der Gewindeeinsätze bis Bruch. Die Prüfungen wurden an je drei Mustern durchgeführt.

Bei den oben beschriebenen Testreihen wurden keine Beeinflussungen durch dynamische Belastung, Temperatur, Alterung etc. berücksichtigt. Diese sind im praktischen Einsatz jedoch mit zu beachten. Die im Katalog angegebenen Tragkraftwerte sind daher nur Anhaltspunkte, die eigene Tests unter Einsatzbedingungen nicht ersetzen.

Load Bearing Tests

FATH levelling feet, hinges and threaded bushes were tested for mechanical load. The following test procedures were applied:

Levelling Feet

Vertical load of the threaded rod over an industry standard nut. After an initial load of approx. 1,500N, the vertical load (perpendicular) was increased slowly and steadily to the load that made the complete unit cave in approx. $1.5 \pm 0.5 \text{ mm}$. The tests were performed on 3 samples each. The bases were put on steel plates. No horizontal force was induced.

Threaded Bushes

Vertical load of the threaded bush and the threaded insert until breaking. The tests were performed on 3 samples each.

Please note that influences from dynamic loads, temperatures, modifications etc. were not taken into account in the above mentioned tests. These influences should be taken into account in the practical application of the products and therefore one should take the load bearing capacities indicated in the catalog as a guideline only and own tests under practical application conditions should not be eliminated.



TELLER FÜR GELENKSTELLFÜßEE, KUGEL 10

BASE FOR SWIVEL FEET, BALL JOINT 10

Ausführung	Kunststoff PA, ohne Anschraubbohrungen	Model	Plastics PA, without Bolt-down Holes
Beschreibung	schwenkbarer, nivellierbarer Stellfuß zum Ausgleich von Bodenunebenheiten	Description	A swiveling leveling foot for strong positioning on uneven floors
Material	Kunststoff PA, glaskugelverstärkt	Material	Plastic PA, glass ball reinforced
Farbe	schwarz	Color	Black
Liefereinheit	10 Stück	Pack Quantity	10 pieces
Extras	☁ elektrostatisch entladend, weitere Größen, weitere Farben, geklebte Anti-Slip-Platte auf Anfrage; als montierter Stellfuß auf Anfrage	Specials	☁ electrostatically discharging, other sizes, other colors, glued anti-slip plate on request; as factory assembled leveling foot on request
Hinweis	passende Gewindestange siehe Seite 14, passende Mutter siehe Seite 80 und Seite 81, passende Anti-Slip Platte siehe Seite 15	Tip	Compatible threaded rod see page 14, Compatible nut see page 80 and page 81, Compatible anti-slip plate see page 15

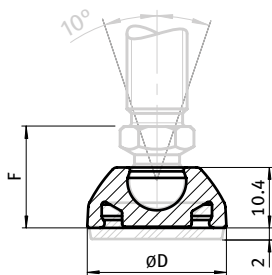

Teller Base	Teller für Gelenkstellfüße, Kugel 10 Base for Swivel Feet, Ball Joint 10	D [mm]	F [mm]	Tragkraft [kg] Max. Load [kg]	Gewicht [g] Weight [g]	Teil-Nr. Part #
20	ohne Anti-Slip-Platte Without Anti-slip plate	19	17.5	100	2.0	098M020K
25	ohne Anti-Slip-Platte Without Anti-slip plate	24	17.5	200	3.0	098M025K
30	ohne Anti-Slip-Platte Without Anti-slip plate	29	17.5	350	4.5	098M030K
40	ohne Anti-Slip-Platte Without Anti-slip plate	39	17.5	500	8.0	098M040K
20	mit Anti-Slip-Platte With Anti-slip plate	19	17.5	100	3.0	098M020KG
25	mit Anti-Slip-Platte With Anti-slip plate	24	17.5	200	4.5	098M025KG
30	mit Anti-Slip-Platte With Anti-slip plate	29	17.5	350	6.5	098M030KG
40	mit Anti-Slip-Platte With Anti-slip plate	39	17.5	500	11.0	098M040KG

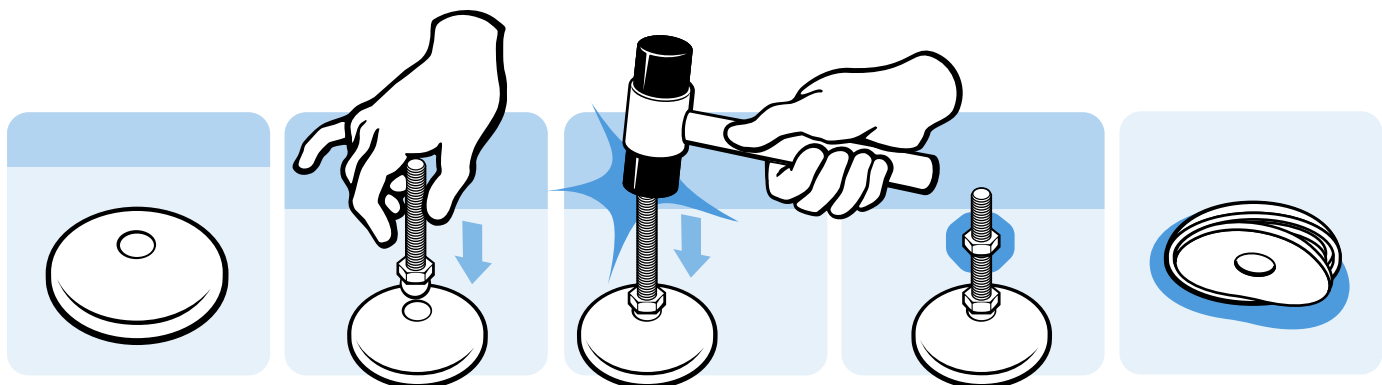

Bodenelemente *Floor Elements*

Stellfüße *Leveling Feet*

Gelenkstellfüße Kugel 10 *Swivel Feet, Ball Joint 10*



GEWINDESTANGE FÜR GELENKSTELLFÜßE, KUGEL 10 *THREADED ROD FOR SWIVEL FEET, BALL JOINT 10*

Ausführung	Stahl	Model	Steel
Beschreibung	Gewindestange für Gelenkstellfüße, Kugel 10	Description	Threaded rod for swiveling levelling feet, ball joint 10
Material	Stahl, verzinkt	Material	Steel, zinc plated
Kugelgelenk	Schwenkbereich ±10°	Ball joint	Swiveling range ±10°
Liefereinheit	10 Stück	Pack Quantity	10 pieces
Extras	Edelstahl, weitere Längen und Größen auf Anfrage	Specials	Stainless steel, other lengths and other sizes on request

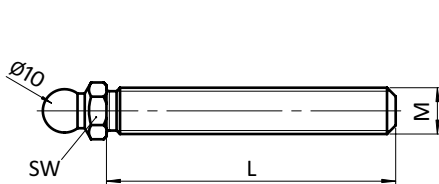

Gewindestange für Gelenkstellfüße, Kugel 10 <i>Threaded Rod for Swivel Feet, Ball Joint 10</i>	M × L	SW [mm]	Tragkraft [kg] <i>Max. Load [kg]</i>	Gewicht [g] <i>Weight [g]</i>	Teil-Nr. <i>Part #</i>
Stahl, verzinkt <i>Steel, zinc plated</i>	M5 × 20	10	50	10.0	098MM05020M
	M5 × 40	10	50	13.0	098MM05040M
	M5 × 60	10	50	15.5	098MM05060M
	M6 × 20	10	100	11.0	098MM06020M
	M6 × 40	10	100	15.0	098MM06040M
	M6 × 60	10	100	21.0	098MM06060M
	M6 × 80	10	100	25.0	098MM06080M
	M8 × 20	13	250	18.0	098MM08020M
	M8 × 40	13	250	20.0	098MM08040M
	M8 × 60	13	250	33.0	098MM08060M
	M8 × 80	13	250	41.0	098MM08080M
	M8 × 100	13	250	49.0	098MM08100M
	M10 × 20	13	400	20.5	098MM10020M
	M10 × 40	13	400	34.0	098MM10040M
	M10 × 60	13	400	46.5	098MM10060M
	M10 × 80	13	400	59.0	098MM10080M
	M10 × 100	13	400	71.0	098MM10100M

Bodenelemente *Floor Elements*

Stellfüße *Leveling Feet*

Gelenkstellfüße Kugel 10 *Swivel Feet, Ball Joint 10*



ANTI-SLIP-PLATTE

ANTI-SLIP PLATE

<p>Ausführung für Gelenkstellfüße, Kugel 10</p> <p>Beschreibung verhindert das Verrutschen von Stellfüßen auf glatten Industrieböden und kann Vibrationen dämpfen</p> <p>Material thermoplastisches Elastomer, ≈70 Shore A</p> <p>Eigenschaften beständig gegen Öl und Wasser (bis 60° C)</p> <p>Liefereinheit 10 Stück</p> <p>Extras elektrostatisch entladend auf Anfrage</p>	<p>Model For swivel feet, ball joint 10</p> <p>Description Prevents movement of leveling feet on slippery surfaces and absorbs some vibration</p> <p>Material Thermoplastic elastomer, ≈70 Shore A</p> <p>Specification Water and oil resistant (up to 60° C)</p> <p>Pack Quantity 10 pieces</p> <p>Specials electrostatically discharging on request</p>
--	--

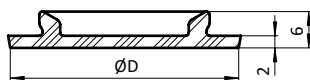

Anti-Slip-Platte Anti-slip Plate	D [mm]	für Teller for Base	Gewicht [g] Weight [g]	Teil-Nr. Part #
	18.5	20	1.0	098MG020
	23.5	25	1.5	098MG025
	28.5	30	2.0	098MG030
	38.5	40	3.0	098MG040

1

Bodenelemente *Floor Elements*

Stellfüße *Leveling Feet*

Gelenkstellfüße Kugel 15 *Swivel Feet, Ball Joint 15*



TELLER FÜR GELENKSTELLFÜßE, KUGEL 15

BASE FOR SWIVEL FEET, BALL JOINT 15

Ausführung	Kunststoff PA, ohne Anschraubbohrungen	Model	Plastic PA, without bolt-down holes
Beschreibung	schwenkbarer, nivellierbarer Stellfuß zum Ausgleich von Bodenunebenheiten	Description	A swiveling leveling foot for a strong positioning on uneven floors
Material	Kunststoff PA, glaskugelverstärkt	Material	Plastic PA, glass ball reinforced
Farbe	schwarz	Color	Black
Liefereinheit	10 Stück	Pack Quantity	10 pieces
Extras	☁elektrostatisch entladend, weitere Größen, weitere Farben, angeschraubte oder geklebte Anti-Slip-Platte auf Anfrage; als montierter Stellfuß auf Anfrage	Specials	☁electrostatically discharging, other sizes, other colors, bolt-on or glued anti-slip plate on request; as factory assembled leveling foot on request
Hinweis	passende Gewindestange siehe Seite 29 f. und Seite 31 f., passende Mutter siehe Seite 80 und Seite 81, passende Anti-Slip Platte siehe Seite 41	Tip	Compatible threaded rod see page 29 et sq. and page 31 et sq., Compatible nut see page 80 and page 81, Compatible anti-slip plate see page 41

F1 (M6 - M16; UNC 1/4" - UNC 1/2")
 F2 (M20 - M30; UNC 5/8" - UNC 2 3/4")
 F3 (UNC 1" - UNC 1 1/4")

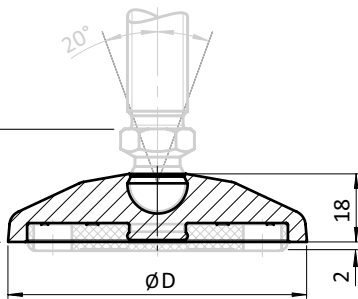

Teller Base	Teller für Gelenkstellfüße, Kugel 15 Base for Swivel Feet, Ball Joint 15	D [mm]	F1 [mm]	F2 [mm]	F3 [mm]	Tragkraft [kg] Max. Load [kg]	Gewicht [g] Weight [g]	Teil-Nr. Part #
30	ohne Anti-Slip-Platte Without anti-slip plate	29	29.5	32.5	33.5	500	8.0	098D030K
40	ohne Anti-Slip-Platte Without anti-slip plate	39	29.5	32.5	33.5	900	13.0	098D040K
45	ohne Anti-Slip-Platte Without anti-slip plate	44	29.5	32.5	33.5	900	15.0	098D045K
50	ohne Anti-Slip-Platte Without anti-slip plate	49	29.5	32.5	33.5	900	16.0	098D050K
60	ohne Anti-Slip-Platte Without anti-slip plate	59	29.5	32.5	33.5	900	22.0	098D060K
80	ohne Anti-Slip-Platte Without anti-slip plate	79	29.5	32.5	33.5	900	44.0	098D080K
100	ohne Anti-Slip-Platte Without anti-slip plate	99	29.5	32.5	33.5	900	84.0	098D100K
30	mit Anti-Slip-Platte With anti-slip plate	29	29.5	32.5	33.5	500	10.0	098D030KG
40	mit Anti-Slip-Platte With anti-slip plate	39	29.5	32.5	33.5	900	17.0	098D040KG
45	mit Anti-Slip-Platte With anti-slip plate	44	29.5	32.5	33.5	900	21.0	098D045KG
50	mit Anti-Slip-Platte With anti-slip plate	49	29.5	32.5	33.5	900	24.0	098D050KG
60	mit Anti-Slip-Platte With anti-slip plate	59	29.5	32.5	33.5	900	34.0	098D060KG
80	mit Anti-Slip-Platte With anti-slip plate	79	29.5	32.5	33.5	900	67.0	098D080KG
100	mit Anti-Slip-Platte With anti-slip plate	99	29.5	32.5	33.5	900	121.0	098D100KG

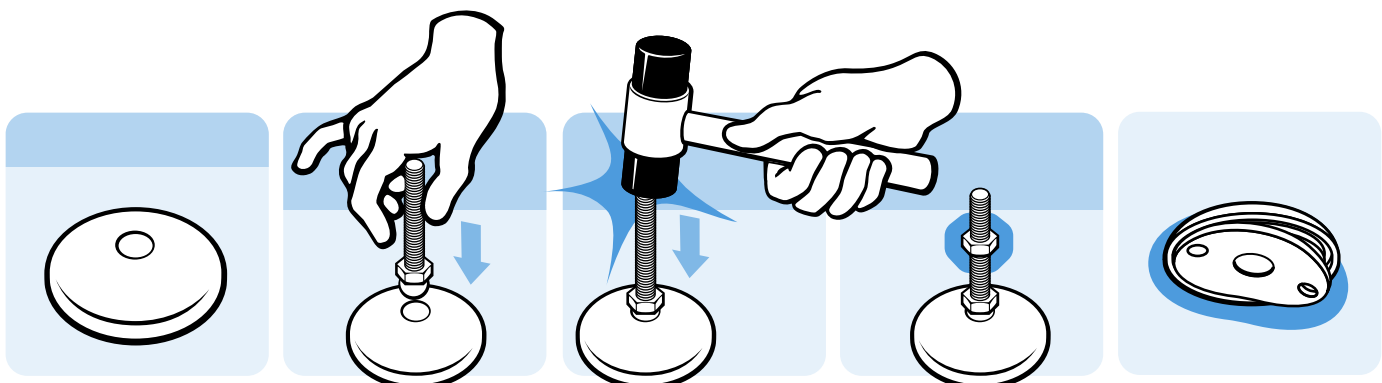

Bodenelemente Floor Elements

Stellfüße Leveling Feet

Gelenkstellfüße Kugel 15 Swivel Feet, Ball Joint 15



TELLER FÜR GELENKSTELLFÜßE, KUGEL 15

BASE FOR SWIVEL FEET, BALL JOINT 15

Ausführung	Kunststoff PA, mit Anschraubbohrungen	Model	Plastic PA, with bolt-down holes
Beschreibung	schwenkbarer, nivellierbarer Stellfuß zur Befestigung am Boden	Description	A swiveling leveling foot which can be fixed to the floor
Material	Kunststoff PA, glaskugelverstärkt	Material	Plastic PA, glass ball reinforced
Farbe	schwarz	Color	Black
Liefereinheit	10 Stück	Pack Quantity	10 pieces
Extras	☁ elektrostatisch entladend, weitere Größen, weitere Farben, angeschraubte oder geklebte Anti-Slip-Platte auf Anfrage; als montierter Stellfuß auf Anfrage	Specials	☁ electrostatically discharging, other sizes, other colors, bolt-on or glued anti-slip plate on request; as factory assembled leveling foot on request
Hinweis	passende Gewindestange siehe Seite 29 f. und Seite 31 f., passende Mutter siehe Seite 80 und Seite 81, passende Anti-Slip Platte siehe Seite 41; * Anschraubbohrung geschlossen	Tip	Compatible threaded rod see page 29 et sq. and page 31 et sq., Compatible nut see page 80 and page 81, Compatible anti-slip plate see page 41; * Bolt-down holes closed

F1 (M6 - M16; UNC 1/4" - UNC 1/2")
 F2 (M20 - M30; UNC 5/8" - UNC 2 1/4")
 F3 (UNC 1" - UNC 1 1/4")

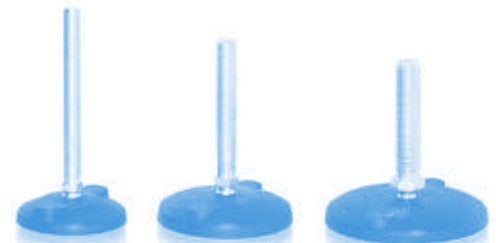
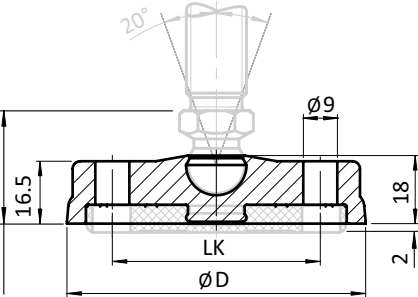

Teller Base	Teller für Gelenkstellfüße, Kugel 15 Base for Swivel Feet, Ball Joint 15	D [mm]	F1 [mm]	F2 [mm]	F3 [mm]	LK [mm]	Tragkraft [kg] Max. Load [kg]	Gewicht [g] Weight [g]	Teil-Nr. Part #
80	ohne Anti-Slip-Platte Without anti-slip plate	79	29.5	32.5	33.5	55	900	46.0	098D080KB
*80	ohne Anti-Slip-Platte Without anti-slip plate	79	29.5	32.5	33.5	55	900	46.0	098D080KBZ
100	ohne Anti-Slip-Platte Without anti-slip plate	99	29.5	32.5	33.5	74	900	86.0	098D100KB
*100	ohne Anti-Slip-Platte Without anti-slip plate	99	29.5	32.5	33.5	74	900	86.0	098D100KBZ
120	ohne Anti-Slip-Platte Without anti-slip plate	119	29.5	32.5	33.5	94	900	104.0	098D120KB
*120	ohne Anti-Slip-Platte Without anti-slip plate	119	29.5	32.5	33.5	94	900	104.0	098D120KBZ
80	mit Anti-Slip-Platte With anti-slip plate	79	29.5	32.5	33.5	55	900	69.0	098D080KBG
*80	mit Anti-Slip-Platte With anti-slip plate	79	29.5	32.5	33.5	55	900	69.0	098D080KBZG
100	mit Anti-Slip-Platte With anti-slip plate	99	29.5	32.5	33.5	74	900	123.0	098D100KBG
*100	mit Anti-Slip-Platte With anti-slip plate	99	29.5	32.5	33.5	74	900	123.0	098D100KBZG
120	mit Anti-Slip-Platte With anti-slip plate	119	29.5	32.5	33.5	94	900	164.0	098D120KBG
*120	mit Anti-Slip-Platte With anti-slip plate	119	29.5	32.5	33.5	94	900	164.0	098D120KBZG

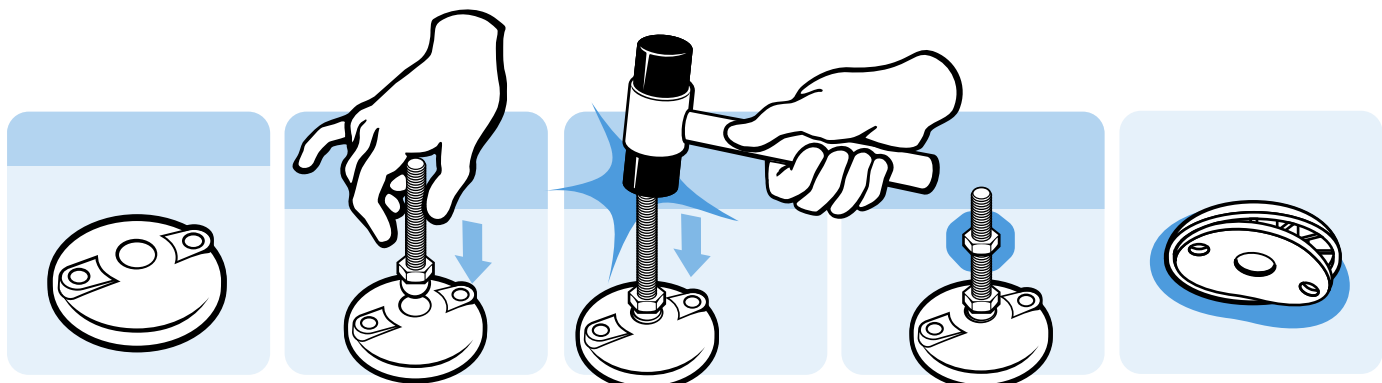

Bodenelemente *Floor Elements*

Stellfüße *Leveling Feet*

Gelenkstellfüße Kugel 15 *Swivel Feet, Ball Joint 15*



TELLER FÜR GELENKSTELLFÜßE, KUGEL 15

BASE FOR SWIVEL FEET, BALL JOINT 15

Ausführung	Zinkdruckguss, ohne Anschraubbohrungen	Model	Zinc die-cast, without bolt-down holes
Beschreibung	schwenkbarer, nivellierbarer Stellfuß zum Ausgleich von Bodenunebenheiten	Description	A swiveling leveling foot for strong positioning on uneven floors
Material	Zinkdruckguss	Material	Zinc die-cast
Liefereinheit	10 Stück	Pack Quantity	10 pieces
Extras	weitere Größen, weitere Oberflächen, weitere Farben, angeschraubte oder geklebte Anti-Slip-Platte auf Anfrage; als montierter Stellfuß auf Anfrage	Specials	Other sizes, other surfaces, other colors, screwed or glued anti-slip plate on request; as factory assembled leveling foot on request
Hinweis	passende Gewindestange siehe Seite 29 f. und Seite 31 f., passende Mutter siehe Seite 80 und Seite 81, passende Anti-Slip Platte siehe Seite 41	Tip	Compatible threaded rod see page 29 et sq. and page 31 et sq., Compatible nut see page 80 and page 81, Compatible anti-slip plate see page 41

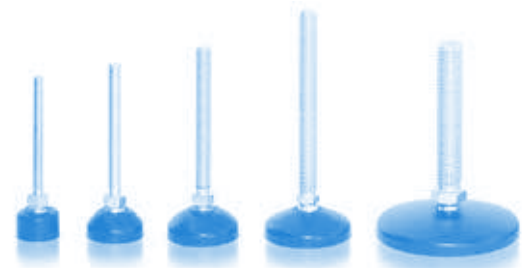
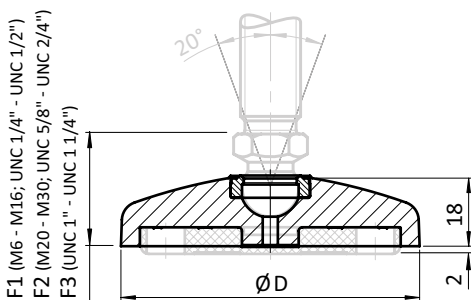

Teller Base	Teller für Gelenkstellsfüße, Kugel 15 Base for Swivel Feet, Ball Joint 15	D [mm]	F1 [mm]	F2 [mm]	F3 [mm]	Tragkraft [kg] Max. Load [kg]	Gewicht [g] Weight [g]	Teil-Nr. Part #
30	ohne Anti-Slip-Platte <i>Without anti-slip plate</i>	29	29.5	32.5	33.5	2000	48.0	098D030ZS
40	ohne Anti-Slip-Platte <i>Without anti-slip plate</i>	39	29.5	32.5	33.5	3000	70.0	098D040ZS
45	ohne Anti-Slip-Platte <i>Without anti-slip plate</i>	44	29.5	32.5	33.5	3000	90.0	098D045ZS
50	ohne Anti-Slip-Platte <i>Without anti-slip plate</i>	49	29.5	32.5	33.5	3000	126.0	098D050ZS
60	ohne Anti-Slip-Platte <i>Without anti-slip plate</i>	59	29.5	32.5	33.5	3000	160.0	098D060ZS
80	ohne Anti-Slip-Platte <i>Without anti-slip plate</i>	79	29.5	32.5	33.5	3000	260.0	098D080ZS
100	ohne Anti-Slip-Platte <i>Without anti-slip plate</i>	99	29.5	32.5	33.5	3500	400.0	098D100ZS
120	ohne Anti-Slip-Platte <i>Without anti-slip plate</i>	119	29.5	32.5	33.5	3500	584.0	098D120ZS
30	mit Anti-Slip-Platte <i>With anti-slip plate</i>	29	29.5	32.5	33.5	2000	50.0	098D030ZSG
40	mit Anti-Slip-Platte <i>With anti-slip plate</i>	39	29.5	32.5	33.5	3000	74.0	098D040ZSG
45	mit Anti-Slip-Platte <i>With anti-slip plate</i>	44	29.5	32.5	33.5	3000	96.0	098D045ZSG
50	mit Anti-Slip-Platte <i>With anti-slip plate</i>	49	29.5	32.5	33.5	3000	134.0	098D050ZSG
60	mit Anti-Slip-Platte <i>With anti-slip plate</i>	59	29.5	32.5	33.5	3000	172.0	098D060ZSG
80	mit Anti-Slip-Platte <i>With anti-slip plate</i>	79	29.5	32.5	33.5	3000	283.0	098D080ZSG
100	mit Anti-Slip-Platte <i>With anti-slip plate</i>	99	29.5	32.5	33.5	3500	437.0	098D100ZSG
120	mit Anti-Slip-Platte <i>With anti-slip plate</i>	119	29.5	32.5	33.5	3500	644.0	098D120ZSG

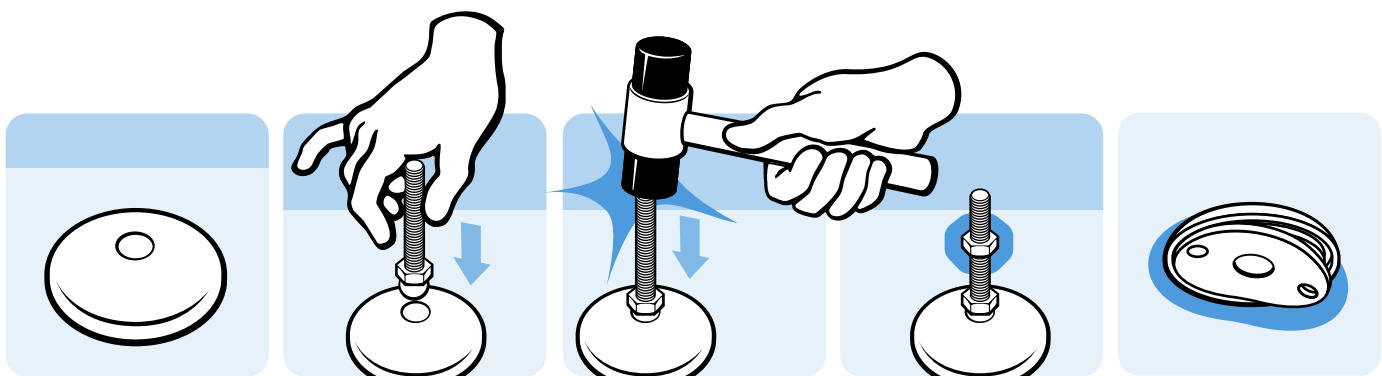



TELLER FÜR GELENKSTELLFÜßE, KUGEL 15

BASE FOR SWIVEL FEET, BALL JOINT 15

Ausführung	Zinkdruckguss, mit Anschraubbohrungen	Model	Zinc die-cast, with bolt-down holes
Beschreibung	schwenkbarer, nivellierbarer Stellfuß zur Befestigung am Boden	Description	A swiveling leveling foot which can be fixed to the floor
Material	Zinkdruckguss	Material	Zinc die-cast
Liefereinheit	10 Stück	Pack Quantity	10 pieces
Extras	weitere Größen, weitere Oberflächen, weitere Farben, angeschraubte oder geklebte Anti-Slip-Platte auf Anfrage; als montierter Stellfuß auf Anfrage	Specials	Other sizes, other surfaces, other colors, screwed or glued anti-slip plate on request; as factory assembled leveling foot on request
Hinweis	passende Gewindestange siehe Seite 29 f. und Seite 31 f., passende Mutter siehe Seite 80 und Seite 81, passende Anti-Slip Platte siehe Seite 41	Tip	Compatible threaded rod see page 29 et sq. and page 31 et sq., Compatible nut see page 80 and page 81, Compatible anti-slip plate see page 41

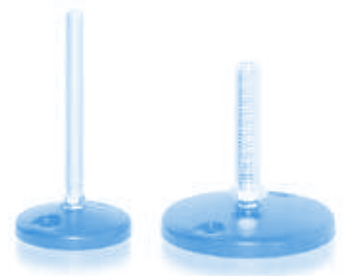
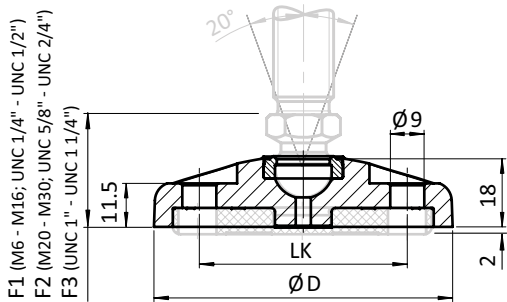

Teller Base	Teller für Gelenkstellfüße, Kugel 15 Base for Swivel Feet, Ball Joint 15	D [mm]	F1 [mm]	F2 [mm]	F3 [mm]	LK [mm]	Tragkraft [kg] Max. Load [kg]	Gewicht [g] Weight [g]	Teil-Nr. Part #
60	ohne Anti-Slip-Platte Without anti-slip plate	59	29.5	32.5	33.5	40	3000	157.0	098D060ZBS
80	ohne Anti-Slip-Platte Without anti-slip plate	79	29.5	32.5	33.5	55	3000	260.0	098D080ZBS
100	ohne Anti-Slip-Platte Without anti-slip plate	99	29.5	32.5	33.5	74	3500	377.0	098D100ZBS
120	ohne Anti-Slip-Platte Without anti-slip plate	119	29.5	32.5	33.5	94	3500	570.0	098D120ZBS
60	mit Anti-Slip-Platte With anti-slip plate	59	29.5	32.5	33.5	40	3000	169.0	098D060ZBSG
80	mit Anti-Slip-Platte With anti-slip plate	79	29.5	32.5	33.5	55	3000	283.0	098D080ZBSG
100	mit Anti-Slip-Platte With anti-slip plate	99	29.5	32.5	33.5	74	3500	414.0	098D100ZBSG
120	mit Anti-Slip-Platte With anti-slip plate	119	29.5	32.5	33.5	94	3500	630.0	098D120ZBSG

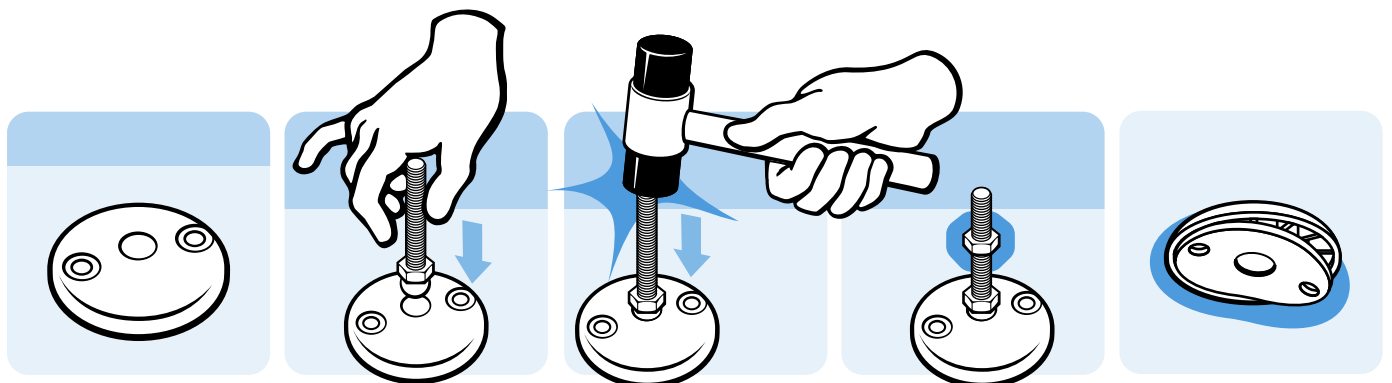

Bodenelemente *Floor Elements*

Stellfüße *Leveling Feet*

Gelenkstellfüße Kugel 15 *Swivel Feet, Ball Joint 15*



TELLER FÜR GELENKSTELLFÜßE, KUGEL 15

BASE FOR SWIVEL FEET, BALL JOINT 15

Ausführung	Edelstahl, ohne Anschraubbohrungen	Model	Stainless steel, without bolt-down holes
Beschreibung	schwenkbarer, nivellierbarer Stellfuß zum Ausgleich von Bodenunebenheiten	Description	A swiveling leveling foot for strong positioning on uneven floors
Material	Edelstahl 1.4305	Material	Stainless steel SS303
Liefereinheit	10 Stück	Pack Quantity	10 pieces
Extras	weitere Größen, geklebte Anti-Slip-Platte auf Anfrage; als montierter Stellfuß auf Anfrage	Specials	Other sizes, glued anti-slip plate on request; as factory assembled leveling foot on request
Hinweis	passende Gewindestange siehe Seite 31 f., passende Mutter siehe Seite 81, passende Anti-Slip Platte siehe Seite 41	Tip	Compatible threaded rod see page 31 et sq., Compatible nut see page 81, Compatible anti-slip plate see page 41

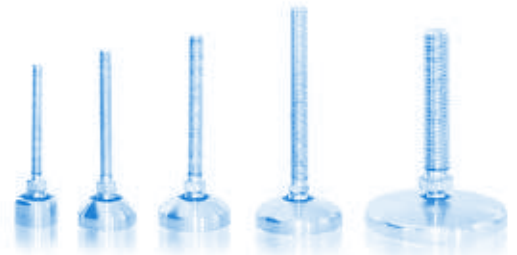
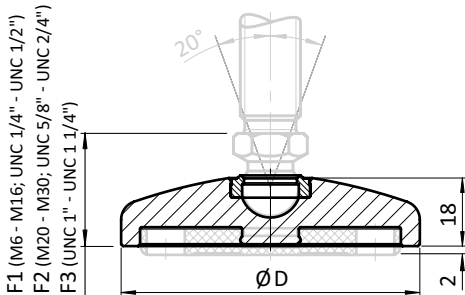

Teller Base	Teller für Gelenkstellfüße, Kugel 15 Base for Swivel Feet, Ball Joint 15	D [mm]	F1 [mm]	F2 [mm]	F3 [mm]	Tragkraft [kg] Max. Load [kg]	Gewicht [g] Weight [g]	Teil-Nr. Part #
30	ohne Anti-Slip-Platte Without anti-slip plate	29	29.5	32.5	33.5	2000	62.0	098D030E
40	ohne Anti-Slip-Platte Without anti-slip plate	39	29.5	32.5	33.5	3000	99.0	098D040E
45	ohne Anti-Slip-Platte Without anti-slip plate	44	29.5	32.5	33.5	3000	123.0	098D045E
50	ohne Anti-Slip-Platte Without anti-slip plate	49	29.5	32.5	33.5	3500	158.0	098D050E
60	ohne Anti-Slip-Platte Without anti-slip plate	59	29.5	32.5	33.5	3500	218.0	098D060E
80	ohne Anti-Slip-Platte Without anti-slip plate	79	29.5	32.5	33.5	3500	380.0	098D080E
100	ohne Anti-Slip-Platte Without anti-slip plate	99	29.5	32.5	33.5	4000	605.0	098D100E
120	ohne Anti-Slip-Platte Without anti-slip plate	119	29.5	32.5	33.5	4000	844.0	098D120E
30	mit Anti-Slip-Platte With anti-slip plate	29	29.5	32.5	33.5	2000	64.0	098D030EG
40	mit Anti-Slip-Platte With anti-slip plate	39	29.5	32.5	33.5	3000	103.0	098D040EG
45	mit Anti-Slip-Platte With anti-slip plate	44	29.5	32.5	33.5	3000	129.0	098D045EG
50	mit Anti-Slip-Platte With anti-slip plate	49	29.5	32.5	33.5	3500	166.0	098D050EG
60	mit Anti-Slip-Platte With anti-slip plate	59	29.5	32.5	33.5	3500	230.0	098D060EG
80	mit Anti-Slip-Platte With anti-slip plate	79	29.5	32.5	33.5	3500	403.0	098D080EG
100	mit Anti-Slip-Platte With anti-slip plate	99	29.5	32.5	33.5	4000	642.0	098D100EG
120	mit Anti-Slip-Platte With anti-slip plate	119	29.5	32.5	33.5	4000	904.0	098D120EG

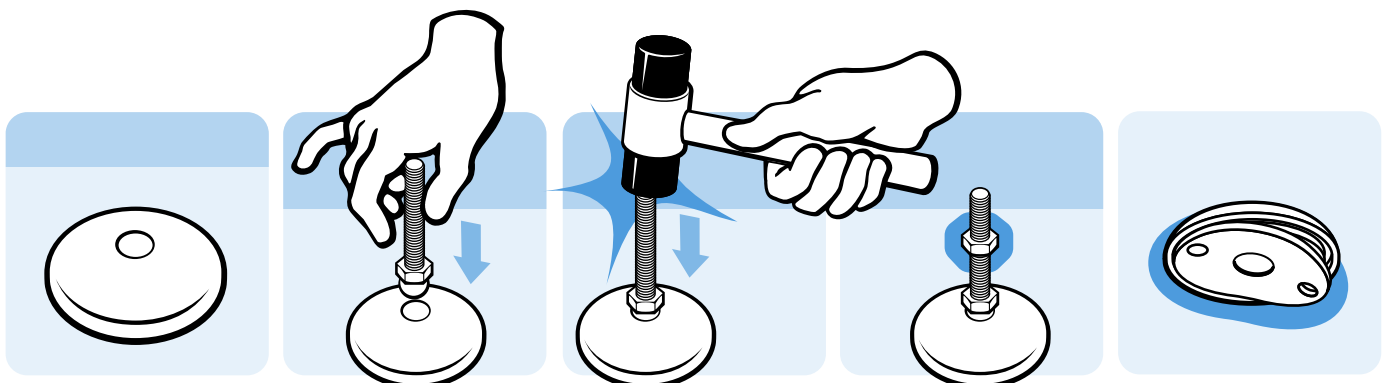

Bodenelemente Floor Elements

Stellfüße Leveling Feet

Gelenkstellfüße Kugel 15 Swivel Feet, Ball Joint 15



TELLER FÜR GELENKSTELLFÜßE, KUGEL 15

BASE FOR SWIVEL FEET, BALL JOINT 15

Ausführung	Edelstahl, mit Anschraubbohrungen	Model	Stainless steel, with bolt-down holes
Beschreibung	schwenkbarer, nivellierbarer Stellfuß zur Befestigung am Boden	Description	A swiveling leveling foot which can be fixed to the floor
Material	Edelstahl 1.4305	Material	Stainless steel SS303
Liefereinheit	10 Stück	Pack Quantity	10 pieces
Extras	weitere Größen, geklebte Anti-Slip-Platte auf Anfrage; als montierter Stellfuß auf Anfrage	Specials	Other sizes, glued anti-slip plate on request; as factory assembled leveling foot on request
Hinweis	passende Gewindestange siehe Seite 31 f., passende Mutter siehe Seite 81, passende Anti-Slip Platte siehe Seite 41	Tip	Compatible threaded rod see page 31 et sq., Compatible nut see page 81, Compatible anti-slip plate see page 41

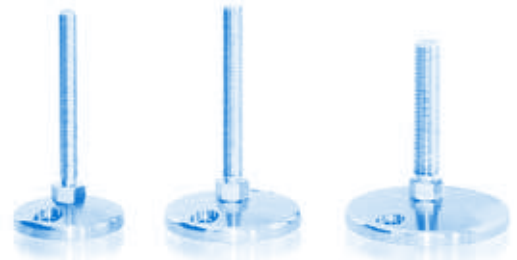
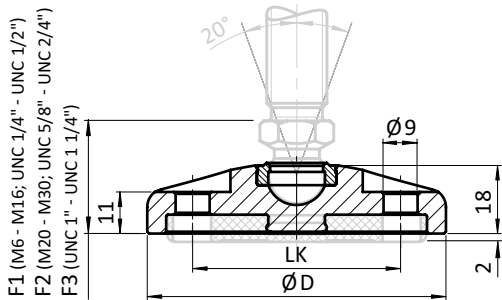

Teller Base	Teller für Gelenkstellfüße, Kugel 15 Base for Swivel Feet, Ball Joint 15	D [mm]	F1 [mm]	F2 [mm]	F3 [mm]	LK [mm]	Tragkraft [kg] Max. Load [kg]	Gewicht [g] Weight [g]	Teil-Nr. Part #
80	ohne Anti-Slip-Platte Without anti-slip plate	79	29.5	32.5	33.5	55	3000	354.0	098D080EB
100	ohne Anti-Slip-Platte Without anti-slip plate	99	29.5	32.5	33.5	74	4000	587.0	098D100EB
120	ohne Anti-Slip-Platte Without anti-slip plate	119	29.5	32.5	33.5	94	4000	830.0	098D120EB
80	mit Anti-Slip-Platte With anti-slip plate	79	29.5	32.5	33.5	55	3000	377.0	098D080EBG
100	mit Anti-Slip-Platte With anti-slip plate	99	29.5	32.5	33.5	74	4000	624.0	098D100EBG
120	mit Anti-Slip-Platte With anti-slip plate	119	29.5	32.5	33.5	94	4000	890.0	098D120EBG

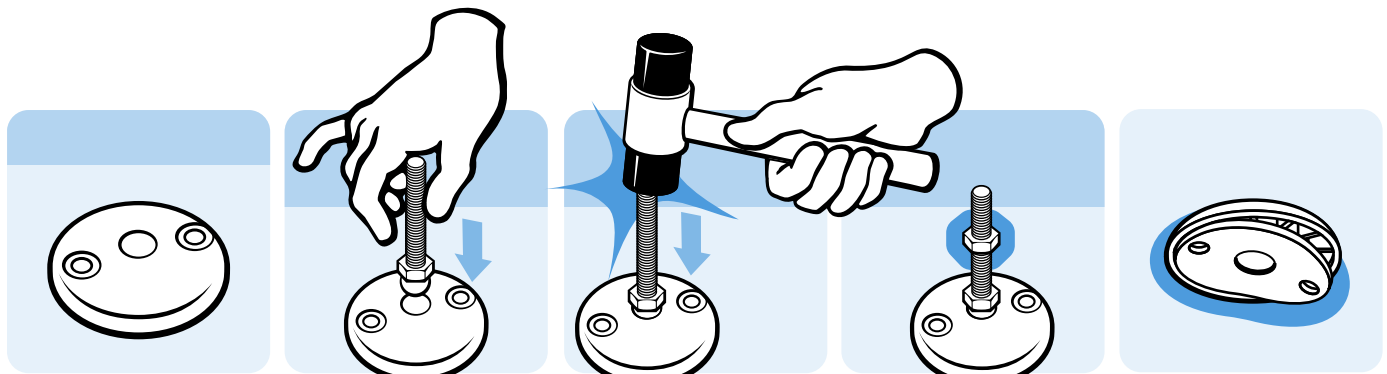

Bodenelemente *Floor Elements*

Stellfüße *Leveling Feet*

Gelenkstellfüße Kugel 15 *Swivel Feet, Ball Joint 15*



TELLER FÜR INTEGRAL-STELLFÜßE, KUGEL 15

BASE FOR SEALED LEVELING FEET, BALL JOINT 15

Ausführung	Edelstahl	Model	Stainless steel
Beschreibung	schwenkbarer, nivellierbarer Stellfuß zum Ausgleich von Bodenunebenheiten; Anti-Slip-Platte integriert; mit Dichtlippe, dicht bis 8° Neigung, max. 20° möglich	Description	Adjustable Pivot foot to equalize uneven floors; with integrated anti-slip plate; including a sealing lip on the bottom that seals up to a slope of 8 degree with a possible max. of 20 degree
Material	Teller: Edelstahl 1.4301 Anti-Slip-Platte: TPE ≈75 Shore A, beständig gegen Öl und Wasser (bis 60°C), mit antibakteriellem und antimikrobiellem Schutz	Material	Base: Stainless steel SS304 Anti-slip Plate: TPE ≈75 Shore A, water and oil resistant (up to 60°C), with antibacterial and anti-microbial protection
Farbe	Anti-Slip-Platte: lichtgrau ≈RAL 7035	Color	Anti-slip Plate: light gray ≈RAL 7035
Liefereinheit	10 Stück	Pack Quantity	10 pieces
Extras	als montierter Stellfuß auf Anfrage	Specials	as factory assembled leveling foot on request
Hinweis	passende Gewindestange siehe Seite 29 f.	Tip	Compatible threaded rod see page 29 et sq.

F1 (M6 - M16; UNC 1/4" - UNC 1/2")
F2 (M20 - M30; UNC 5/8" - UNC 2 1/4")
F3 (UNC 1" - UNC 1 1/4")

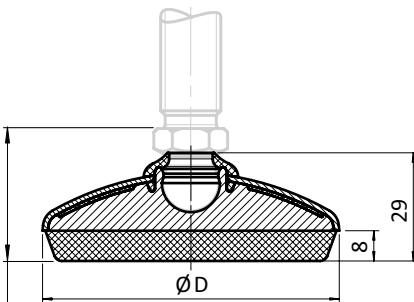

Teller Base	D [mm]	F1 [mm]	F2 [mm]	F3 [mm]	Tragkraft [kg] Max. Load [kg]	Gewicht [g] Weight [g]	Teil-Nr. Part #
60	58.5	35.0	38.0	39.0	700	75.0	098DE060EG
80	78.5	35.0	38.0	39.0	700	150.0	098DE080EG
100	98.5	35.0	38.0	39.0	700	220.0	098DE100EG

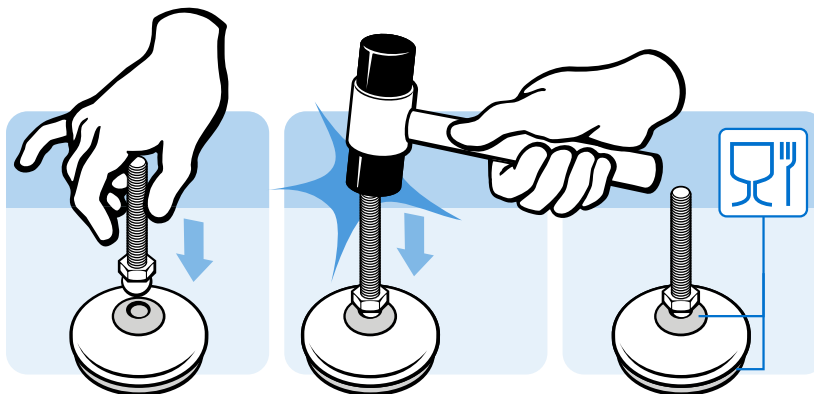

Bodenelemente Floor Elements

Stellfüße Leveling Feet

Gelenkstellfüße Kugel 15 Swivel Feet, Ball Joint 15



TELLER 40 MIT AUSLEGER FÜR GELENKSTELLFÜßE

EXTENDED BASE 40 FOR SWIVEL FEET, BALL JOINT 15

Ausführung	Kunststoff PA	Model	Plastic PA
Beschreibung	schwenkbarer, nivellierbarer Stellfuß zur stabilen Befestigung am Boden	Description	Extended swiveling leveling foot which can be fixed to the floor
Material	Kunststoff PA, glaskugelverstärkt	Material	Plastic PA, glass ball reinforced
Farbe	schwarz	Color	Black
Liefereinheit	10 Stück	Pack Quantity	10 pieces
Extras	☁ elektrostatisch entladend, weitere Farben, angeschraubte oder geklebte Anti-Slip-Platte auf Anfrage; als montierter Stellfuß auf Anfrage	Specials	☁ electrostatically discharging, other colors, bolt-on or glued anti-slip plate on request; as factory assembled leveling foot on request
Hinweis	passende Gewindestange siehe Seite 29 f., passende Mutter siehe Seite 80 f., passende Anti-Slip Platte siehe Seite 41	Tip	Compatible threaded rod see page 29 et sq., Compatible nut see page 80 et sq., Compatible anti-slip plate see page 41

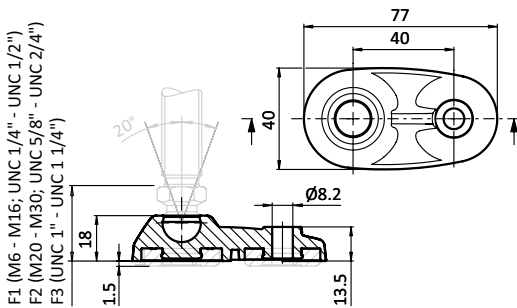

Teller Base	Teller 40 mit Ausleger für Gelenkstellfüße, Kugel 15 Extended Base 40 for Swivel Feet, Ball Joint 15	F1 [mm]	F2 [mm]	F3 [mm]	Tragkraft [kg] Max. Load [kg]	Gewicht [g] Weight [g]	Teil-Nr. Part #
40	ohne Anti-Slip-Platte Without anti-slip plate	29.5	32.5	33.5	600	20.0	098DA040K
40	mit Anti-Slip-Platte With anti-slip plate	29.5	32.5	33.5	600	28.0	098DA040KG

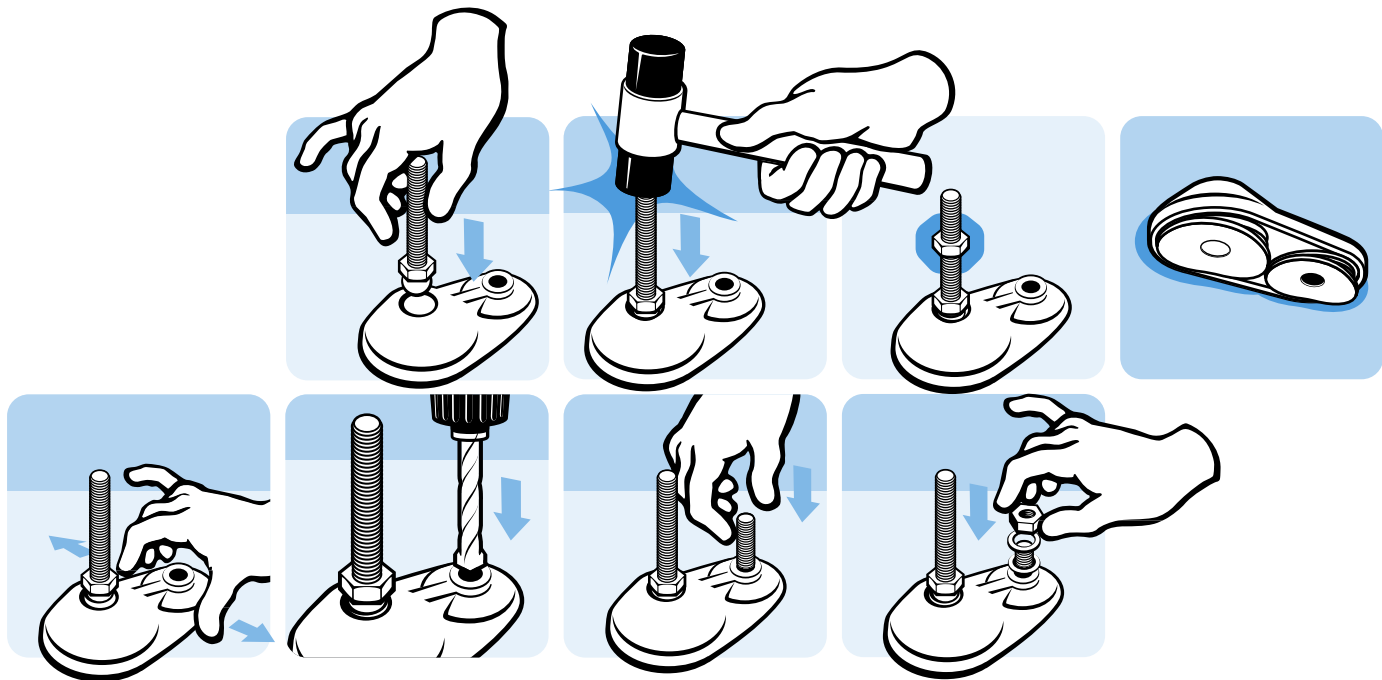

Bodenelemente *Floor Elements*

Stellfüße *Leveling Feet*

Gelenkstellfüße Kugel 15 *Swivel Feet, Ball Joint 15*



TELLER 60 MIT AUSLEGER FÜR GELENKSTELLFÜßE

EXTENDED BASE 60 FOR SWIVEL FEET, BALL JOINT 15

Ausführung	Kunststoff PA	Model	Plastic PA
Beschreibung	schwenkbarer, nivellierbarer Stellfuß zur stabilen Befestigung am Boden	Description	Extended swiveling leveling foot which can be fixed to the floor
Material	Kunststoff PA, glaskugelverstärkt	Material	Plastic PA, glass ball reinforced
Farbe	schwarz	Color	Black
Liefereinheit	10 Stück	Pack Quantity	10 pieces
Extras	☁elektrostatisch entladend, weitere Farben, angeschraubte oder geklebte Anti-Slip-Platte auf Anfrage; als montierter Stellfuß auf Anfrage	Specials	☁electrostatically discharging, other colors, bolt-on or glued anti-slip plate on request; as factory assembled leveling foot on request
Hinweis	passende Gewindestange siehe Seite 29 f., passende Mutter siehe Seite 80 f., passende Anti-Slip Platte siehe Seite 42	Tip	Compatible threaded rod see page 29 et sq., Compatible nut see page 80 et sq., Compatible anti-slip plate see page 42

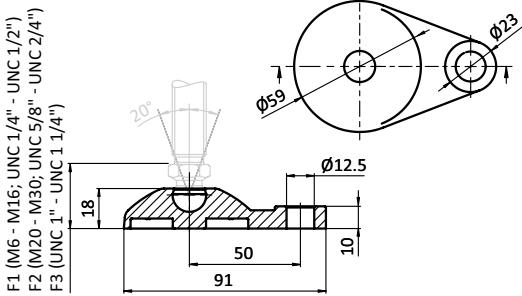

Teller Base	Teller 60 mit Ausleger für Gelenkstellfüße, Kugel 15 Extended Base 60 for Swivel Feet, Ball Joint 15	F1 [mm]	F2 [mm]	F3 [mm]	Tragkraft [kg] Max. Load [kg]	Gewicht [g] Weight [g]	Teil-Nr. Part #
60	ohne Anti-Slip-Platte Without anti-slip plate	29.5	32.5	33.5	900.0	24.0	098DA060K

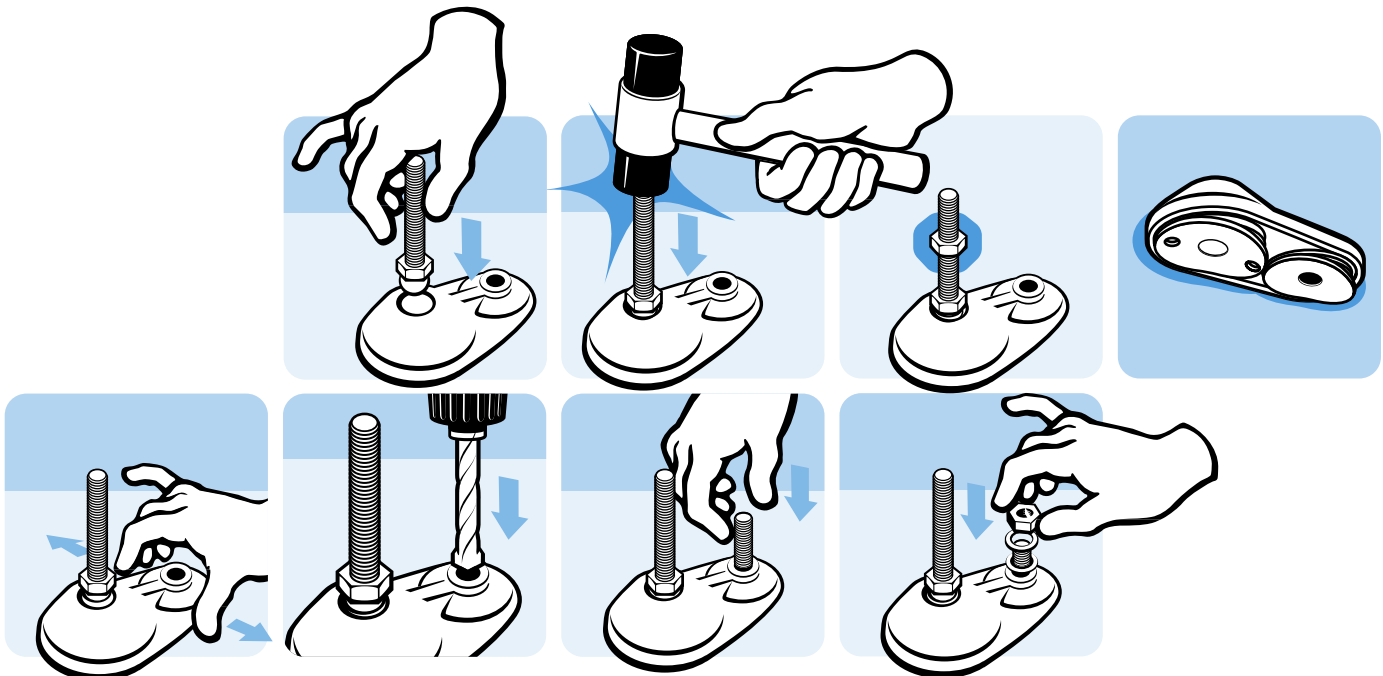



TELLER 80 MIT AUSLEGER FÜR GELENKSTELLFÜßE

EXTENDED BASE 80 FOR SWIVEL FEET, BALL JOINT 15

Ausführung	Kunststoff PA	Model	Plastic PA
Beschreibung	schwenkbarer, nivellierbarer Stellfuß zur stabilen Befestigung am Boden	Description	Extended swiveling leveling foot which can be fixed to the floor
Material	Kunststoff PA, glaskugelverstärkt	Material	Plastic PA, glass ball reinforced
Farbe	schwarz	Color	Black
Liefereinheit	10 Stück	Pack Quantity	10 pieces
Extras	☁ elektrostatisch entladend, weitere Größen, weitere Farben, angeschraubte oder geklebte Anti-Slip-Platte auf Anfrage; als montierter Stellfuß auf Anfrage	Specials	☁ electrostatically discharging, other sizes, other colors, bolt-on or glued anti-slip plate on request; as factory assembled leveling foot on request
Hinweis	passende Gewindestange siehe Seite 29 f., passende Mutter siehe Seite 80 f., passende Anti-Slip Platte siehe Seite 41	Tip	Compatible threaded rod see page 29 et sq., Compatible nut see page 80 et sq., Compatible anti-slip plate see page 41

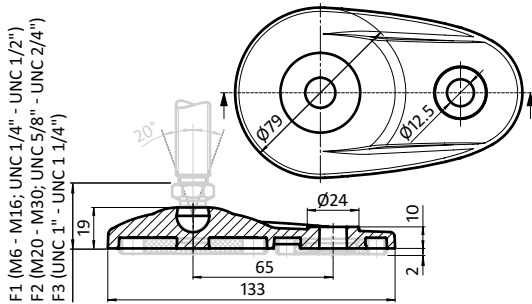

Teller Base	Teller 80 mit Ausleger für Gelenkstellfüße, Kugel 15 Extended Base 80 for Swivel Feet, Ball Joint 15	F1 [mm]	F2 [mm]	F3 [mm]	Tragkraft [kg] Max. Load [kg]	Gewicht [g] Weight [g]	Teil-Nr. Part #
80	ohne Anti-Slip-Platte Without anti-slip plate	30.5	33.5	34.5	1000	58.8	098DA080K
80	mit Anti-Slip-Platte With anti-slip plate	30.5	33.5	34.5	1000	93.8	098DA080KG

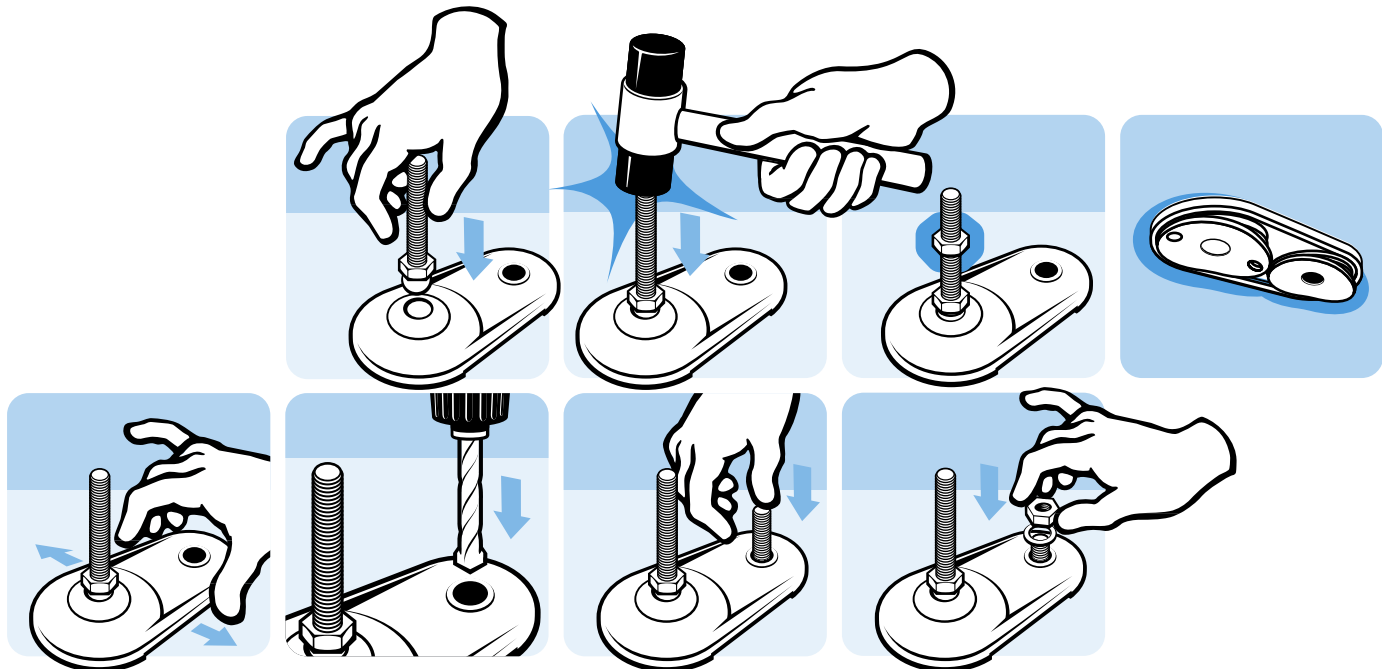

Bodenelemente *Floor Elements*

Stellfüße *Leveling Feet*

Gelenkstellfüße Kugel 15 *Swivel Feet, Ball Joint 15*



TELLER 80 MIT AUSLEGER FÜR GELENKSTELLFÜßE

EXTENDED BASE 80 FOR SWIVEL FEET, BALL JOINT 15

Ausführung	Zinkdruckguss	Model	Zinc die-cast
Beschreibung	schwenkbarer, nivellierbarer Stellfuß zur stabilen Befestigung am Boden	Description	Extended swiveling leveling foot which can be fixed to the floor
Material	Zinkdruckguss	Material	Zinc die-cast
Liefereinheit	10 Stück	Pack Quantity	10 pieces
Extras	weitere Oberflächen, weitere Größen, weitere Farben, angeschraubte oder geklebte Anti-Slip-Platte auf Anfrage; als montierter Stellfuß auf Anfrage	Specials	Other surfaces, other sizes, other colors, screwed or glued anti-slip plate on request; as factory assembled leveling foot on request
Hinweis	passende Gewindestange siehe Seite 29 f., passende Mutter siehe Seite 80 f., passende Anti-Slip Platte siehe Seite 41	Tip	Compatible threaded rod see page 29 et sq., Compatible nut see page 80 et sq., Compatible anti-slip plate see page 41

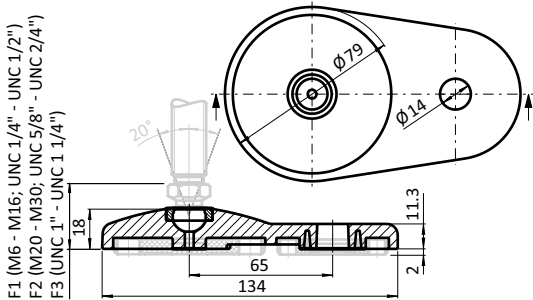

Teller Base	Teller 80 mit Ausleger für Gelenkstellsfüße, Kugel 15 Extended Base 80 for Swivel Feet, Ball Joint 15	F1 [mm]	F2 [mm]	F3 [mm]	Tragkraft [kg] Max. Load [kg]	Gewicht [g] Weight [g]	Teil-Nr. Part #
80	ohne Anti-Slip-Platte <i>Without anti-slip plate</i>	29.5	32.5	33.5	3000	399.0	098DA080ZS
80	mit Anti-Slip-Platte <i>With anti-slip plate</i>	29.5	32.5	33.5	3000	434.0	098DA080ZSG

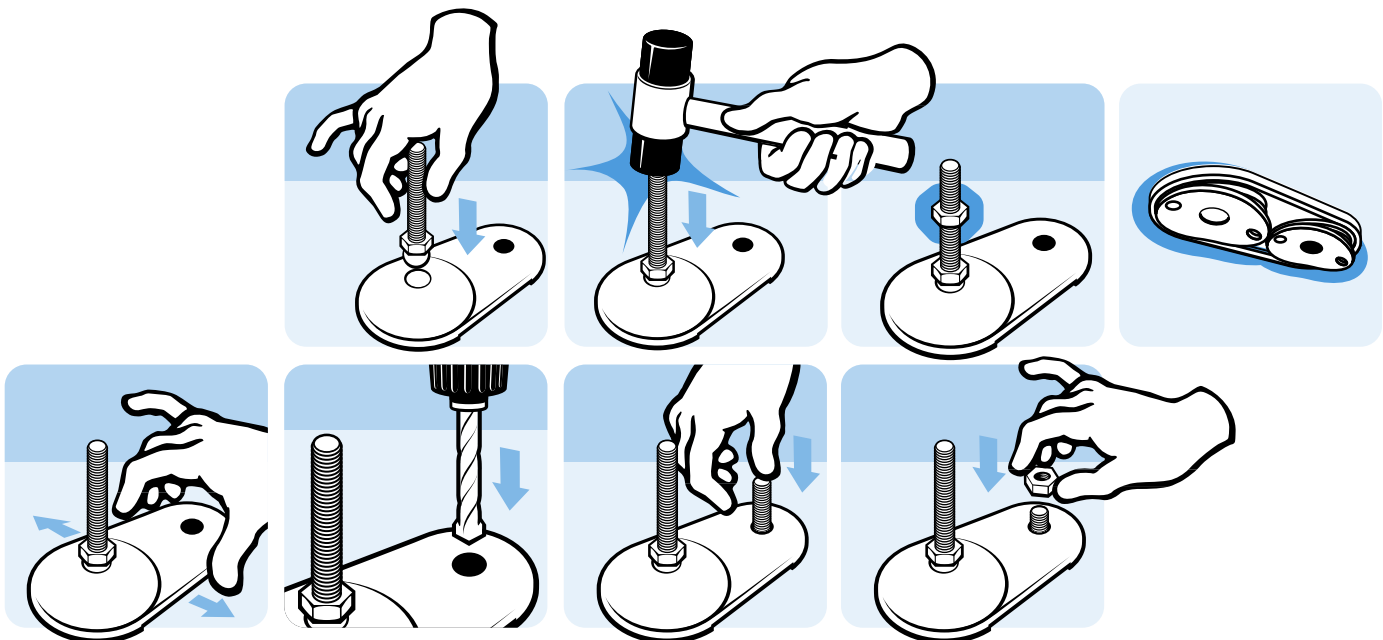



TRAPEZTELLER FÜR GELENKSTELLFÜßE, KUGEL 15

TRAPEZOID BASE FOR SWIVEL FEET, BALL JOINT 15

Ausführung	Zinkdruckguss	Model	Zinc die-cast
Beschreibung	schwenkbarer, nivellierbarer Stellfuß zum Ausgleich von Bodenunebenheiten	Description	A swiveling leveling foot for strong positioning on uneven floors
Material	Zinkdruckguss	Material	Zinc die-cast
Liefereinheit	10 Stück	Pack Quantity	10 pieces
Extras	weitere Oberflächen, weitere Größen, weitere Farben, angeschraubte oder geklebte Anti-Slip-Platte auf Anfrage; als montierter Stellfuß auf Anfrage	Specials	Other surfaces, other sizes, other colors, screwed or glued anti-slip plate on request; as factory assembled leveling foot on request
Hinweis	passende Gewindestange siehe Seite 29 f., passende Mutter siehe Seite 80 f., passende Anti-Slip Platte siehe Seite 41, passende Lasche zur Bodenbefestigung siehe Seite 55	Tip	Compatible threaded rod see page 29 et sq., Compatible nut see page 80 et sq., Compatible anti-slip plate see page 41, Compatible floor mounting see page 55

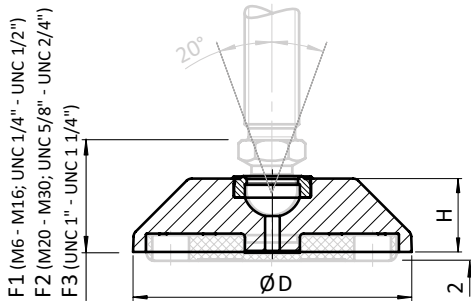

Teller Base	Trapezteller für Gelenkstellfüße, Kugel 15 Trapezoid Base for Swivel Feet, Ball Joint 15	D [mm]	F1 [mm]	F2 [mm]	F3 [mm]	H [mm]	Tragkraft [kg] Max. Load [kg]	Gewicht [g] Weight [g]	Teil-Nr. Part #
60	ohne Anti-Slip-Platte Without anti-slip plate	59	29.5	32.5	33.5	18	2500	98.0	098DI060ZS
80	ohne Anti-Slip-Platte Without anti-slip plate	76	29.5	32.5	33.5	20	3000	199.0	098DI080ZS
60	mit Anti-Slip-Platte With anti-slip plate	59	29.5	32.5	33.5	18	2500	110.0	098DI060ZSG
80	mit Anti-Slip-Platte With anti-slip plate	76	29.5	32.5	33.5	20	3000	122.0	098DI080ZSG

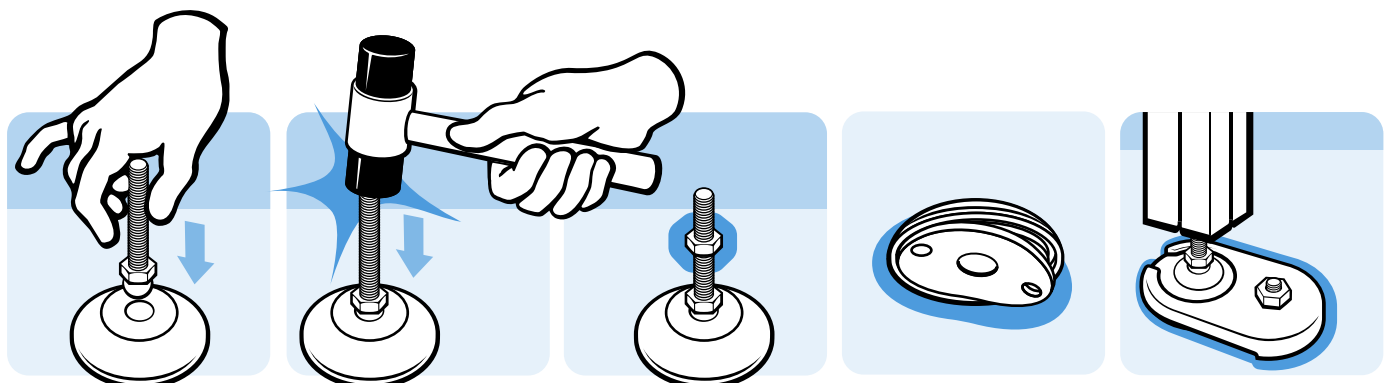

Bodenelemente Floor Elements

Stellfüße Leveling Feet

Gelenkstellfüße Kugel 15 Swivel Feet, Ball Joint 15



QUADRATTELLER FÜR GELENKSTELLFÜßE, KUGEL 15

SQUARE BASE FOR SWIVEL FEET, BALL JOINT 15

Ausführung	Zinkdruckguss	Model	Zinc die-cast
Beschreibung	schwenkbarer, nivellierbarer Stellfuß zum Ausgleich von Bodenunebenheiten	Description	A swiveling leveling foot for strong positioning on uneven floors
Material	Zinkdruckguss	Material	Zinc die-cast
Liefereinheit	10 Stück	Pack Quantity	10 pieces
Extras	weitere Oberflächen, weitere Größen, weitere Farben, Anschraubbohrungen, angeschraubte oder geklebte Anti-Slip-Platte auf Anfrage; als montierter Stellfuß auf Anfrage	Specials	Other surfaces, other sizes, other colors, bolt down holes, screwed or glued anti-slip plate on request; as factory assembled leveling foot on request
Hinweis	passende Gewindestange siehe Seite 29 f., passende Mutter siehe Seite 80 f., passende Anti-Slip Platte siehe Seite 43	Tip	Compatible threaded rod see page 29 et sq., Compatible nut see page 80 et sq., Compatible anti-slip plate see page 43

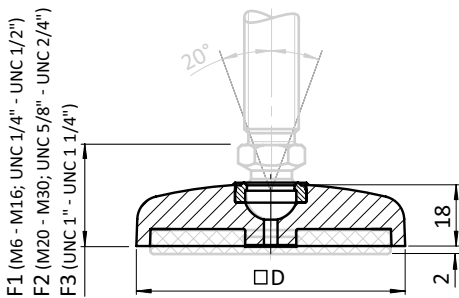

Quadratteller für Gelenkstellsfüße, Kugel 15 Square Base for Swivel Feet, Ball Joint 15	Teller Base	D [mm]	F1 [mm]	F2 [mm]	F3 [mm]	Tragkraft [kg] Max. Load [kg]	Gewicht [g] Weight [g]	Teil-Nr. Part #
ohne Anti-Slip-Platte Without anti-slip plate	60	59 × 59	29.5	32.5	33.5	2500	175.0	098DV060ZS
	80	79 × 79	29.5	32.5	33.5	3000	323.0	098DV080ZS
	100	99 × 99	29.5	32.5	33.5	3500	483.0	098DV100ZS
mit Anti-Slip-Platte With anti-slip plate	60	59 × 59	29.5	32.5	33.5	2500	201.0	098DV060ZSG
	80	79 × 79	29.5	32.5	33.5	3000	360.0	098DV080ZSG
	100	99 × 99	29.5	32.5	33.5	3500	530.0	098DV100ZSG

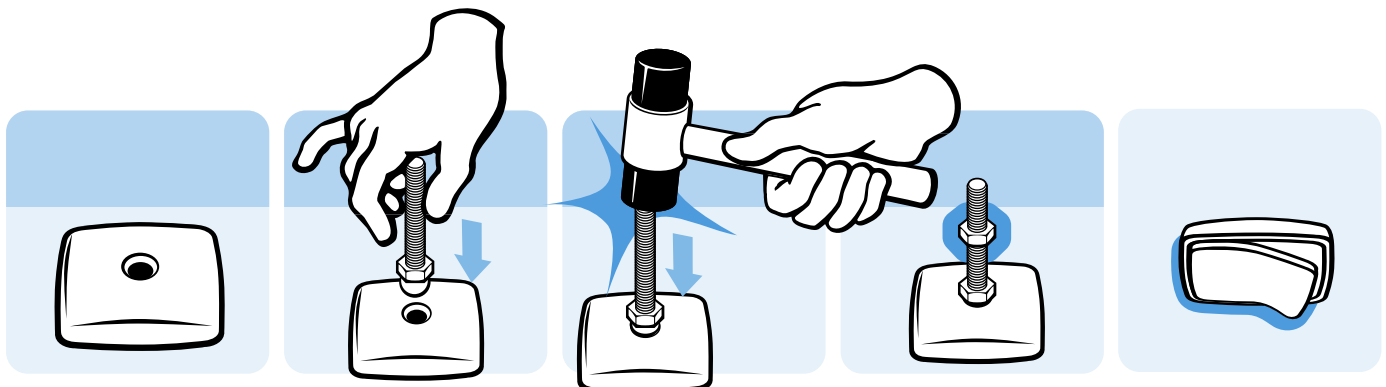

Bodenelemente *Floor Elements*

Stellfüße *Leveling Feet*

Gelenkstellfüße Kugel 15 *Swivel Feet, Ball Joint 15*



GEWINDESTANGE FÜR GELENKSTELLFÜßE, KUGEL 15 *THREADED ROD FOR SWIVEL FEET, BALL JOINT 15*

Ausführung Stahl	Model <i>Steel</i>
Beschreibung Gewindestange für Gelenkstellfüße	Description <i>Threaded rod for swiveling leveling feet</i>
Material Stahl, verzinkt	Material <i>Steel, zinc plated</i>
Kugelgelenk Schwenkbereich ±20°	Ball joint <i>Swiveling range ±20°</i>
Liefereinheit 10 Stück	Pack Quantity <i>10 pieces</i>
Extras weitere Längen und Größen auf Anfrage	Specials <i>Other lengths and sizes on request</i>

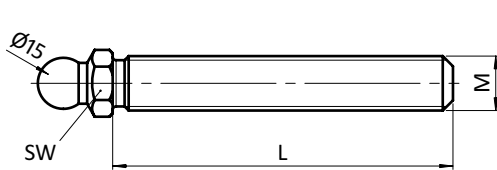

Gewindestange Stahl für Gelenkstellfüße, Kugel 15 <i>Threaded Rod for Swivel Feet, Ball Joint 15</i>	M × L [mm]	SW [mm]	Tragkraft [kg] <i>Max. Load [kg]</i>	Gewicht [g] <i>Weight [g]</i>	Teil-Nr. <i>Part #</i>
Stahl, verzinkt <i>Steel, zinc plated</i>	M8 × 25	14	350	29.0	098DM08025M
	M8 × 40	14	350	36.0	098DM08040M
	M8 × 80	14	350	49.0	098DM08080M
	M10 × 45	14	470	45.0	098DM10045M
	M10 × 70	14	470	55.0	098DM10070M
	M10 × 90	14	470	68.0	098DM10090M
	M10 × 125	14	470	84.0	098DM10125M
	M10 × 150	14	470	92.0	098DM10150M
	M12 × 45	14	770	55.0	098DM12045M
	M12 × 66	14	770	70.0	098DM12066M
	M12 × 100	14	770	94.0	098DM12100M
	M12 × 125	14	770	112.0	098DM12125M
	M12 × 150	14	770	130.0	098DM12150M
	M14 × 66	14	1110	85.0	098DM14066M
	M14 × 100	14	1110	119.0	098DM14100M
	M14 × 125	14	1110	138.0	098DM14125M
	M14 × 150	14	1110	166.0	098DM14150M
	M16 × 66	17	1450	112.0	098DM16066M
	M16 × 100	17	1450	156.0	098DM16100M
	M16 × 125	17	1450	190.0	098DM16125M
	M16 × 150	17	1450	222.0	098DM16150M
	M16 × 200	17	1450	285.0	098DM16200M

Bodenelemente *Floor Elements*

Stellfüße *Leveling Feet*

Gelenkstellfüße Kugel 15 *Swivel Feet, Ball Joint 15*



GEWINDESTANGE FÜR GELENKSTELLFÜßE, KUGEL 15 *THREADED ROD FOR SWIVEL FEET, BALL JOINT 15*

Ausführung Stahl	Model <i>Steel</i>
Beschreibung Gewindestange für Gelenkstellfüße	Description <i>Threaded rod for swiveling leveling feet</i>
Material Stahl, verzinkt	Material <i>Steel, zinc plated</i>
Kugelgelenk Schwenkbereich ±20°	Ball joint <i>Swiveling range ±20°</i>
Liefereinheit 10 Stück	Pack Quantity <i>10 pieces</i>
Extras weitere Längen und Größen auf Anfrage	Specials <i>Other lengths and sizes on request</i>

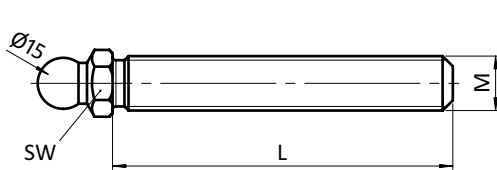

Gewindestange Stahl für Gelenkstellfüße, Kugel 15 <i>Threaded Rod for Swivel Feet, Ball Joint 15</i>	M × L [mm]	SW [mm]	Tragkraft [kg] <i>Max. Load [kg]</i>	Gewicht [g] <i>Weight [g]</i>	Teil-Nr. <i>Part #</i>
Stahl, verzinkt <i>Steel, zinc plated</i>	M20 × 85	22	2430	208.0	098DM20085M
	M20 × 100	22	2430	237.0	098DM20100M
	M20 × 125	22	2430	297.0	098DM20125M
	M20 × 150	22	2430	341.0	098DM20150M
	M20 × 200	22	2430	447.0	098DM20200M
	M20 × 250	22	2430	551.0	098DM20250M
	M24 × 85	24	3610	293.0	098DM24085M
	M24 × 100	24	3610	336.0	098DM24100M
	M24 × 125	24	3610	408.0	098DM24125M
	M24 × 150	24	3610	483.0	098DM24150M
	M24 × 200	24	3610	633.0	098DM24200M
	M24 × 250	24	3610	783.0	098DM24250M

Bodenelemente *Floor Elements*

Stellfüße *Leveling Feet*

Gelenkstellfüße Kugel 15 *Swivel Feet, Ball Joint 15*



GEWINDESTANGE FÜR GELENKSTELLFÜßE, KUGEL 15 *THREADED ROD FOR SWIVEL FEET, BALL JOINT 15*

Ausführung	Edelstahl	Model	Stainless steel
Beschreibung	Gewindestange für Gelenkstellfüße	Description	Threaded rod for swiveling leveling feet
Material	Edelstahl 1.4301	Material	Stainless steel SS304
Kugelgelenk	Schwenkbereich ±20°	Ball joint	Swiveling range ±20°
Liefereinheit	10 Stück	Pack Quantity	10 pieces
Extras	weitere Längen und Größen auf Anfrage	Specials	Other lengths and sizes on request

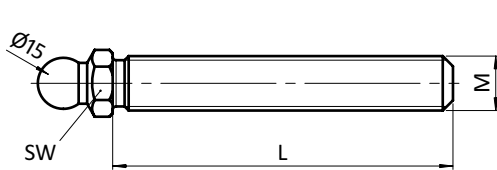

Gewindestange für Gelenkstellfüße, Kugel 15 <i>Threaded Rod for Swivel Feet, Ball Joint 15</i>	M × L [mm]	SW [mm]	Tragkraft [kg] <i>Max. Load [kg]</i>	Gewicht [g] <i>Weight [g]</i>	Teil-Nr. <i>Part #</i>
Edelstahl <i>Stainless steel</i>	M8 × 25	14	350	29.0	098DM08025E
	M8 × 40	14	350	36.0	098DM08040E
	M8 × 80	14	350	49.0	098DM08080E
	M10 × 45	14	470	45.0	098DM10045E
	M10 × 70	14	470	55.0	098DM10070E
	M10 × 90	14	470	68.0	098DM10090E
	M10 × 125	14	470	84.0	098DM10125E
	M10 × 150	14	470	92.0	098DM10150E
	M12 × 45	14	770	55.0	098DM12045E
	M12 × 66	14	770	70.0	098DM12066E
	M12 × 100	14	770	94.0	098DM12100E
	M12 × 125	14	770	112.0	098DM12125E
	M12 × 150	14	770	130.0	098DM12150E
	M14 × 66	14	1110	85.0	098DM14066E
	M14 × 100	14	1110	119.0	098DM14100E
	M14 × 125	14	1110	138.0	098DM14125E
	M14 × 150	14	1110	166.0	098DM14150E
	M16 × 66	17	1450	112.0	098DM16066E
	M16 × 100	17	1450	156.0	098DM16100E
	M16 × 125	17	1450	190.0	098DM16125E
	M16 × 150	17	1450	222.0	098DM16150E
	M16 × 200	17	1450	285.0	098DM16200E

Bodenelemente *Floor Elements*

Stellfüße *Leveling Feet*

Gelenkstellfüße Kugel 15 *Swivel Feet, Ball Joint 15*

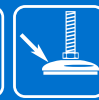

GEWINDESTANGE FÜR GELENKSTELLFÜßE, KUGEL 15 *THREADED ROD FOR SWIVEL FEET, BALL JOINT 15*

Ausführung	Edelstahl	Model	Stainless steel
Beschreibung	Gewindestange für Gelenkstellfüße	Description	Threaded rod for swiveling leveling feet
Material	Edelstahl 1.4301	Material	Stainless steel SS304
Kugelgelenk	Schwenkbereich ±20°	Ball joint	Swiveling range ±20°
Liefereinheit	10 Stück	Pack Quantity	10 pieces
Extras	weitere Längen und Größen auf Anfrage	Specials	Other lengths and sizes on request

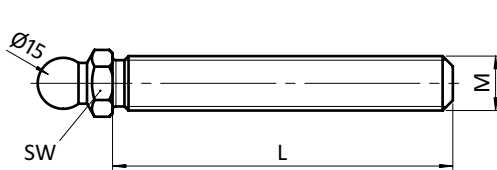

Gewindestange für Gelenkstellfüße, Kugel 15 <i>Threaded Rod for Swivel Feet, Ball Joint 15</i>	M × L [mm]	SW [mm]	Tragkraft [kg] <i>Max. Load [kg]</i>	Gewicht [g] <i>Weight [g]</i>	Teil-Nr. <i>Part #</i>
Edelstahl <i>Stainless steel</i>	M20 × 85	22	2430	208.0	098DM20085E
	M20 × 100	22	2430	237.0	098DM20100E
	M20 × 125	22	2430	297.0	098DM20125E
	M20 × 150	22	2430	341.0	098DM20150E
	M20 × 200	22	2430	447.0	098DM20200E
	M20 × 250	22	2430	551.0	098DM20250E
	M24 × 85	24	3610	293.0	098DM24085E
	M24 × 100	24	3610	336.0	098DM24100E
	M24 × 125	24	3610	408.0	098DM24125E
	M24 × 150	24	3610	483.0	098DM24150E
	M24 × 200	24	3610	633.0	098DM24200E
	M24 × 250	24	3610	783.0	098DM24250E

Bodenelemente *Floor Elements*

Stellfüße *Leveling Feet*

Gelenkstellfüße Kugel 15 *Swivel Feet, Ball Joint 15*



UNC-GEWINDESTANGE FÜR GELENKSTELLFÜßE

UNC THREADED ROD FOR SWIVEL FEET, BALL JOINT 15

Ausführung Stahl	Model Steel
Beschreibung Gewindestange für Gelenkstellfüße	Description Threaded rod for swiveling leveling feet
Material Stahl, verzinkt	Material Steel, zinc plated
Kugelgelenk Schwenkbereich ±20°	Ball joint Swiveling range ±20°
Liefereinheit 10 Stück	Pack Quantity 10 pieces
Extras weitere Längen und Größen auf Anfrage	Specials Other lengths and sizes on request

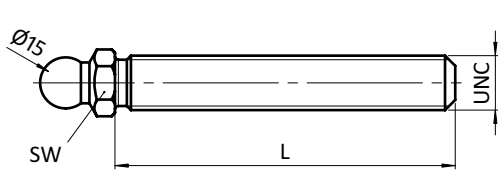

UNC-Gewindestange für Gelenkstellfüße, Kugel 15 UNC Threaded Rod for Swivel Feet, Ball Joint 15	SW [mm]	UNC × L [in]	Tragkraft [kg] Max. Load [kg]	Gewicht [g] Weight [g]	Teil-Nr. Part #
Stahl, verzinkt <i>Steel, zinc plated</i>	22 - 7/8"	3/4-10 UNC × 3"	2430	192.0	098DU3/4-3M
	22 - 7/8"	3/4-10 UNC × 4"	2430	241.0	098DU3/4-4M
	22 - 7/8"	3/4-10 UNC × 5"	2430	283.0	098DU3/4-5M
	22 - 7/8"	3/4-10 UNC × 6"	2430	330.0	098DU3/4-6M
	22 - 7/8"	3/4-10 UNC × 6.5"	2430	353.0	098DU3/4-6,5M
	22 - 7/8"	3/4-10 UNC × 8"	2430	426.0	098DU3/4-8M
	22 - 7/8"	3/4-10 UNC × 9.5"	2430	496.0	098DU3/4-9,5M
	22 - 7/8"	1-8 UNC × 4"	3610	336.0	098DU1-4M
	22 - 7/8"	1-8 UNC × 5"	3610	408.0	098DU1-5M
	22 - 7/8"	1-8 UNC × 6"	3610	483.0	098DU1-6M
	22 - 7/8"	1-8 UNC × 8"	3610	633.0	098DU1-8M

1

Bodenelemente *Floor Elements*

Stellfüße *Leveling Feet*

Gelenkstellfüße Kugel 15 *Swivel Feet, Ball Joint 15*



UNC-GEWINDESTANGE FÜR GELENKSTELLFÜßE

UNC THREADED ROD FOR SWIVEL FEET, BALL JOINT 15

Ausführung	Edelstahl	Model	Stainless steel
Beschreibung	Gewindestange für Gelenkstellfüße	Description	Threaded rod for swiveling leveling feet
Material	Edelstahl 1.4301	Material	Stainless steel SS304
Kugelgelenk	Schwenkbereich ±20°	Ball joint	Swiveling range ±20°
Liefereinheit	10 Stück	Pack Quantity	10 pieces
Extras	weitere Längen und Größen auf Anfrage	Specials	Other lengths and sizes on request



UNC-Gewindestange für Gelenkstellfüße, Kugel 15 UNC Threaded Rod for Swivel Feet, Ball Joint 15	SW [mm]	UNC × L [in]	Tragkraft [kg] Max. Load [kg]	Gewicht [g] Weight [g]	Teil-Nr. Part #
Edelstahl <i>Stainless steel</i>	14 - 9/16"	1/4-20 UNC × 1.5"	210	32.0	098DU1/4-1,5E
	14 - 9/16"	5/16-18 UNC × 1.5"	350	37.0	098DU5/16-1,5E
	14 - 9/16"	5/16-18 UNC × 2.5"	350	45.0	098DU5/16-2,5E
	14 - 9/16"	5/16-18 UNC × 3.5"	350	53.0	098DU5/16-3,5E
	14 - 9/16"	3/8-16 UNC × 1.5"	470	43.0	098DU3/8-1,5E
	14 - 9/16"	3/8-16 UNC × 2"	470	48.0	098DU3/8-2E
	14 - 9/16"	3/8-16 UNC × 2.5"	470	55.0	098DU3/8-2,5E
	14 - 9/16"	3/8-16 UNC × 3"	470	59.0	098DU3/8-3E
	14 - 9/16"	3/8-16 UNC × 4"	470	69.0	098DU3/8-4E
	14 - 9/16"	3/8-16 UNC × 5"	470	81.0	098DU3/8-5E
	14 - 9/16"	3/8-16 UNC × 6"	470	92.0	098DU3/8-6E

Bodenelemente *Floor Elements*

Stellfüße *Leveling Feet*

Gelenkstellfüße Kugel 15 *Swivel Feet, Ball Joint 15*



KUGELKOPF MIT INNENGEWINDE, KUGEL 15

BALL JOINT WITH FEMALE THREAD, BALL JOINT 15

Ausführung	für Gelenkstellfüße, Stahl / Edelstahl	Model	For swivel feet, steel / stainless steel
Beschreibung	zur direkten Befestigung von Stellfüßen mittels Standardschrauben	Description	To fix leveling feet using standard screws
Material	Stahl, verzinkt / Edelstahl 1.4301	Material	Steel, zinc plated / stainless steel SS304
Liefereinheit	10 Stück	Pack Quantity	10 pieces

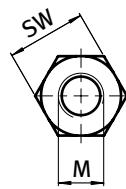
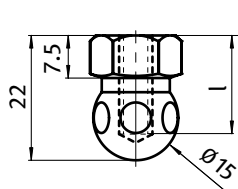

Kugelpkopf mit Innengewinde, Kugel 15 <i>Ball Joint with Female Thread, Ball Joint 15</i>	SW	Gewicht [g] <i>Weight [g]</i>	Teil-Nr. <i>Part #</i>
Stahl, verzinkt <i>Steel, zinc plated</i>	14 mm	20.0	098DSW14M06M
	14 mm	20.0	098DSW14M08M
	14 mm - 9/16"	20.0	098DSW14U1/4M
Edelstahl <i>Stainless steel</i>	14 mm	20.0	098DSW14M06E
	14 mm	20.0	098DSW14M08E
	14 mm - 9/16"	20.0	098DSW14U1/4E



TELLER FÜR GELENKSTELLFÜßE, KUGEL 22

BASE FOR SWIVEL FEET, BALL JOINT 22

<p>Ausführung Kunststoff PA, ohne Anschraubbohrungen</p> <p>Beschreibung schwenkbarer, nivellierbarer Stellfuß zum Ausgleich von Bodenunebenheiten</p> <p>Material Kunststoff PA, glaskugelverstärkt</p> <p>Farbe schwarz</p> <p>Liefereinheit 10 Stück</p> <p>Extras elektrostatisch entladend, weitere Größen, weitere Farben, angeschraubte oder geklebte Anti-Slip-Platte auf Anfrage; als montierter Stellfuß auf Anfrage</p> <p>Hinweis passende Gewindestange siehe Seite 39, passende Mutter siehe Seite 80 f., passende Anti-Slip Platte siehe Seite 41</p>	<p>Model Plastic PA, without bolt-down holes</p> <p>Description A swiveling leveling foot for strong positioning on uneven floors</p> <p>Material Plastic PA, glass ball reinforced</p> <p>Color Black</p> <p>Pack Quantity 10 pieces</p> <p>Specials electrostatically discharging, other sizes, other colors, bolt-on or glued anti-slip plate on request; as factory assembled leveling foot on request</p> <p>Tip Compatible threaded rod see page 39, Compatible nut see page 80 et sq., Compatible anti-slip plate page 41</p>
--	--

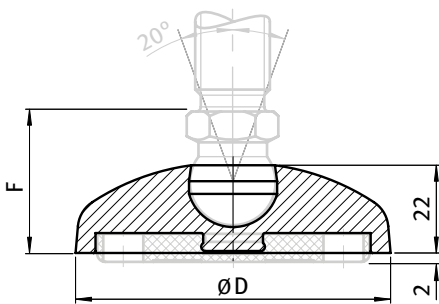

Teller Base	Teller für Gelenkstellfüße, Kugel 22 Base for Swivel Feet, Ball Joint 22	D [mm]	F [mm]	Tragkraft [kg] Max. Load [kg]	Gewicht [g] Weight [g]	Teil-Nr. Part #
60	ohne Anti-Slip-Platte <i>Without anti-slip plate</i>	59	38.5	1000	27.5	098C060K
80	ohne Anti-Slip-Platte <i>Without anti-slip plate</i>	79	38.5	1200	48.9	098C080K
100	ohne Anti-Slip-Platte <i>Without anti-slip plate</i>	99	38.5	1200	72.0	098C100K
60	mit Anti-Slip-Platte <i>With anti-slip plate</i>	59	38.5	1000	39.5	098C060KG
80	mit Anti-Slip-Platte <i>With anti-slip plate</i>	79	38.5	1200	71.9	098C080KG
100	mit Anti-Slip-Platte <i>With anti-slip plate</i>	99	38.5	1200	109.0	098C100KG

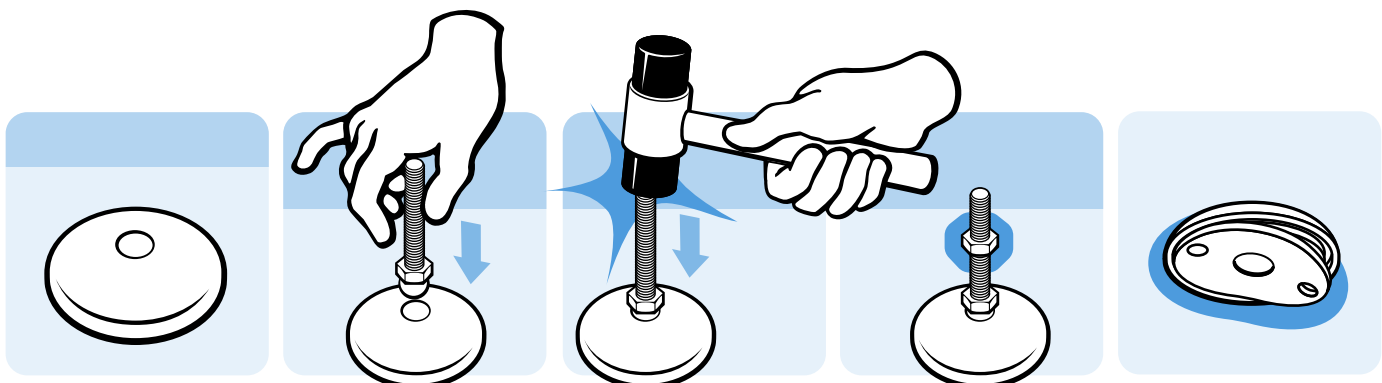



TELLER FÜR GELENKSTELLFÜßE, KUGEL 22

BASE FOR SWIVEL FEET, BALL JOINT 22

Ausführung	Kunststoff PA, mit Anschraubbohrungen	Model	Plastic PA, without bolt-down holes
Beschreibung	schwenkbarer, nivellierbarer Stellfuß zur Befestigung am Boden	Description	A swiveling leveling foot which can be fixed to the floor
Material	Kunststoff PA, glaskugelverstärkt	Material	Plastic PA, glass ball reinforced
Farbe	schwarz	Color	Black
Liefereinheit	10 Stück	Pack Quantity	10 pieces
Extras	☁elektrostatisch entladend, weitere Größen, weitere Farben, angeschraubte oder geklebte Anti-Slip-Platte auf Anfrage; als montierter Stellfuß auf Anfrage	Specials	☁electrostatically discharging, other sizes, other colors, bolt-on or glued anti-slip plate on request; as factory assembled leveling foot on request
Hinweis	passende Gewindestange siehe Seite 39, passende Mutter siehe Seite 80 f., passende Anti-Slip Platte siehe Seite 41; * Anschraubbohrung geschlossen	Tip	Compatible threaded rod see page 39, Compatible nut see page 80 et sq., Compatible anti-slip plate page 41; * Bolt-down holes closed

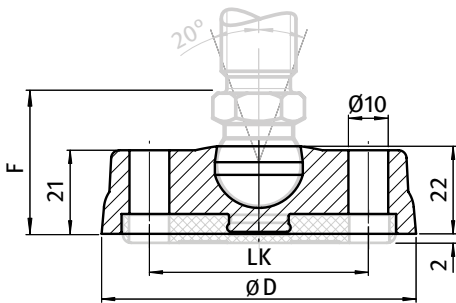

Teller Base	Teller für Gelenkstellfüße, Kugel 22 Base for Swivel Feet, Ball Joint 22	D [mm]	F [mm]	LK [mm]	Tragkraft [kg] Max. Load [kg]	Gewicht [g] Weight [g]	Teil-Nr. Part #
80	ohne Anti-Slip-Platte Without anti-slip plate	79	38.5	55	1200	54.0	098C080KB
*80	ohne Anti-Slip-Platte Without anti-slip plate	79	38.5	55	1200	54.8	098C080KBZ
100	ohne Anti-Slip-Platte Without anti-slip plate	99	38.5	74	1200	72.0	098C100KB
*100	ohne Anti-Slip-Platte Without anti-slip plate	99	38.5	74	1200	87.0	098C100KBZ
80	mit Anti-Slip-Platte With anti-slip plate	79	38.5	55	1200	77.0	098C080KBG
*80	mit Anti-Slip-Platte With anti-slip plate	79	38.5	55	1200	77.8	098C080KBZG
100	mit Anti-Slip-Platte With anti-slip plate	99	38.5	74	1200	109.0	098C100KBG
*100	mit Anti-Slip-Platte With anti-slip plate	99	38.5	74	1200	124.0	098C100KBZG

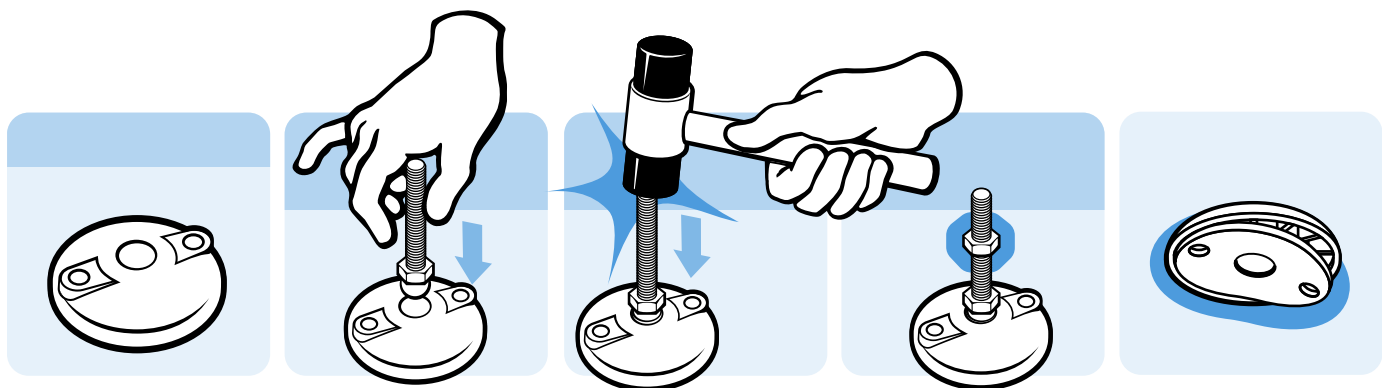



TELLER FÜR GELENK-SCHWERLASTFÜßE, KUGEL 22

BASE FOR HEAVY-DUTY SWIVEL FEET, BALL JOINT 22

<p>Ausführung Kunststoff PA, mit Anschraubbohrungen</p> <p>Beschreibung schwenkbarer, nivellierbarer Stellfuß für schwere Maschinen</p> <p>Material Kunststoff PA, glaskugelverstärkt</p> <p>Farbe schwarz</p> <p>Liefereinheit 1 Stück</p> <p>Extras elektrostatisch entladend, weitere Größen, weitere Farben, angeschraubte oder geklebte Anti-Slip-Platte auf Anfrage; als montierter Stellfuß auf Anfrage</p> <p>Hinweis passende Gewindestange siehe Seite 39, passende Mutter siehe Seite 80 f., passende Anti-Slip Platte siehe Seite 44</p>	<p>Model Plastic PA, with bolt-down holes</p> <p>Description A swiveling leveling foot for a strong positioning of heavy machinery on uneven floors</p> <p>Material Plastic PA, glass ball reinforced</p> <p>Color Black</p> <p>Pack Quantity 1 piece</p> <p>Specials electrostatically discharging, other sizes, other colors, bolt-on or glued anti-slip plate on request; as factory assembled leveling foot on request</p> <p>Tip Compatible threaded rod see page 39, Compatible nut see page 80 et sq., Compatible anti-slip plate page 44</p>
--	--

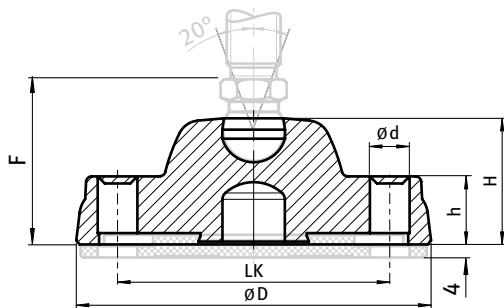

Teller Base	Teller für Gelenk-Schwerlastfüße, Kugel 22 Base for Heavy-duty Swivel Feet, Ball Joint 22	D [mm]	F [mm]	H [mm]	LK [mm]	Tragkraft [kg] Max. Load [kg]	Gewicht [g] Weight [g]	Teil-Nr. Part #
125	ohne Anti-Slip-Platte Without anti-slip plate	125	61.5	44	96	1800	239.0	098CK125KBZ
175	ohne Anti-Slip-Platte Without anti-slip plate	175	63.5	46	135	2500	343.0	098CK175KBZ
125	mit Anti-Slip-Platte With anti-slip plate	125	61.5	44	96	1800	327.0	098CK125KBZG
175	mit Anti-Slip-Platte With anti-slip plate	175	63.5	46	135	2500	565.0	098CK175KBZG

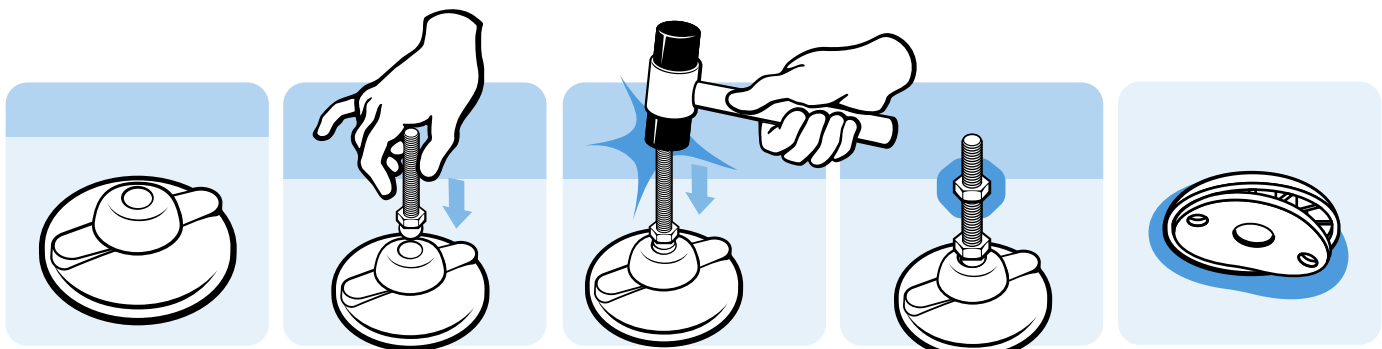

Bodenelemente *Floor Elements*

Stellfüße *Leveling Feet*

Gelenkstellfüße Kugel 22 *Swivel Feet, Ball Joint 22*



GEWINDESTANGE FÜR GELENKSTELLFÜßE, KUGEL 22 *THREADED ROD FOR SWIVEL FEET, BALL JOINT 22*

Ausführung	Stahl	Model	Steel
Beschreibung	Gewindestange für Gelenkstellfüße, Kugel 22	Description	Threaded rod for swiveling leveling feet, ball joint 22
Material	Stahl, verzinkt	Material	Steel, zinc plated
Kugelgelenk	Schwenkbereich ±20°	Ball joint	Swiveling range ±20°
Liefereinheit	10 Stück	Pack Quantity	10 pieces
Extras	weitere Längen und Größen auf Anfrage	Specials	Other lengths and sizes on request

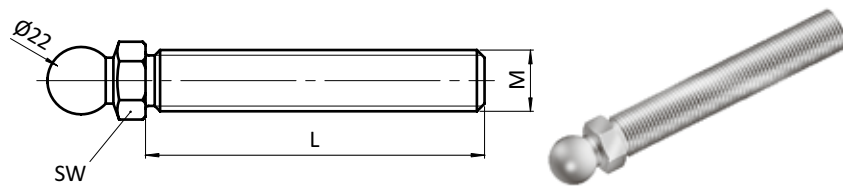

Gewindestange für Gelenkstellfüße, Kugel 22 <i>Threaded Rod for Swivel Feet, Ball Joint 22</i>	M × L [mm]	SW [mm]	Tragkraft [kg] <i>Max. Load [kg]</i>	Gewicht [g] <i>Weight [g]</i>	Teil-Nr. <i>Part #</i>
Stahl, verzinkt <i>Steel, zinc plated</i>	M16 × 66	22	1450	112.0	098CM16066M
	M16 × 100	22	1450	156.0	098CM16100M
	M16 × 125	22	1450	190.0	098CM16125M
	M16 × 150	22	1450	222.0	098CM16150M
	M16 × 200	22	1450	285.0	098CM16200M
	M20 × 85	22	2430	208.0	098CM20085M
	M20 × 100	22	2430	237.0	098CM20100M
	M20 × 125	22	2430	297.0	098CM20125M
	M20 × 150	22	2430	341.0	098CM20150M
	M20 × 200	22	2430	447.0	098CM20200M
	M20 × 250	22	2430	551.0	098CM20250M
	M24 × 85	24	3610	293.0	098CM24085M
	M24 × 100	24	3610	336.0	098CM24100M
	M24 × 125	24	3610	408.0	098CM24125M
	M24 × 150	24	3610	483.0	098CM24150M
	M24 × 200	24	3610	633.0	098CM24200M
	M24 × 250	24	3610	783.0	098CM24250M
	M30 × 100	24	5770	512.0	098CM30100M
	M30 × 150	24	5770	744.0	098CM30150M
	M30 × 200	24	5770	976.0	098CM30200M
	M30 × 250	24	5770	1115.0	098CM30250M
	M30 × 300	24	5770	1420.0	098CM30300M

Bodenelemente *Floor Elements*

Stellfüße *Leveling Feet*

Gelenkstellfüße Kugel 22 *Swivel Feet, Ball Joint 22*



GEWINDESTANGE FÜR GELENKSTELLFÜßE, KUGEL 22 *THREADED ROD FOR SWIVEL FEET, BALL JOINT 22*

Ausführung	Edelstahl	Model	Stainless steel
Beschreibung	Gewindestange für Gelenkstellfüße, Kugel 22	Description	Threaded rod for swiveling leveling feet, ball joint 22
Material	Edelstahl 1.4301	Material	Stainless steel SS304
Kugelgelenk	Schwenkbereich ±20°	Ball joint	Swiveling range ±20°
Liefereinheit	10 Stück	Pack Quantity	10 pieces
Extras	weitere Längen und Größen auf Anfrage	Specials	Other lengths and sizes on request

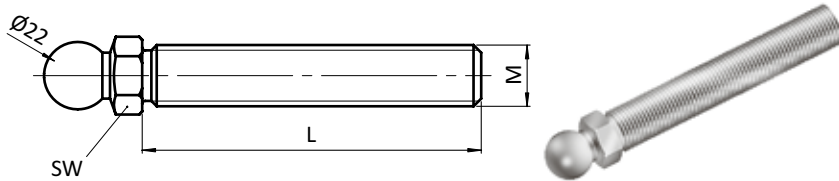

Gewindestange für Gelenkstellfüße, Kugel 22 <i>Threaded Rod for Swivel Feet, Ball Joint 22</i>	M × L [mm]	SW [mm]	Tragkraft [kg] <i>Max. Load [kg]</i>	Gewicht [g] <i>Weight [g]</i>	Teil-Nr. <i>Part #</i>
Edelstahl <i>Stainless steel</i>	M16 × 66	22	1450	112.0	098CM16066E
	M16 × 100	22	1450	156.0	098CM16100E
	M16 × 125	22	1450	190.0	098CM16125E
	M16 × 150	22	1450	222.0	098CM16150E
	M16 × 200	22	1450	285.0	098CM16200E
	M20 × 85	22	2430	208.0	098CM20085E
	M20 × 100	22	2430	237.0	098CM20100E
	M20 × 125	22	2430	297.0	098CM20125E
	M20 × 150	22	2430	341.0	098CM20150E
	M20 × 200	22	2430	447.0	098CM20200E
	M20 × 250	22	2430	551.0	098CM20250E
	M24 × 85	24	3610	293.0	098CM24085E
	M24 × 100	24	3610	336.0	098CM24100E
	M24 × 125	24	3610	408.0	098CM24125E
	M24 × 150	24	3610	483.0	098CM24150E
	M24 × 200	24	3610	633.0	098CM24200E
	M24 × 250	24	3610	783.0	098CM24250E
	M30 × 100	24	5770	512.0	098CM30100E
	M30 × 150	24	5770	744.0	098CM30150E
	M30 × 200	24	5770	976.0	098CM30200E
	M30 × 250	24	5770	1115.0	098CM30250E
	M30 × 300	24	5770	1420.0	098CM30300E



ANTI-SLIP-PLATTE

ANTI-SLIP PLATE

<p>Ausführung für Gelenkstellfüße Kugel 15 und Kugel 22</p> <p>Beschreibung verhindert das Verrutschen von Stellfüßen auf glatten Industrieböden und kann Vibrationen dämpfen</p> <p>Material thermoplastisches Elastomer, ≈70 Shore A</p> <p>Eigenschaften beständig gegen Öl und Wasser (bis 60 °C)</p> <p>Liefereinheit 10 Stück</p> <p>Extras elektrostatisch entladend auf Anfrage</p> <p>Hinweis * auch für Teller mit Anschraubbohrungen</p>	<p>Model For swivel feet, ball joint 15 and ball joint 22</p> <p>Description Prevents movement of leveling feet on slippery surfaces and absorbs some vibration</p> <p>Material Thermoplastic elastomer, ≈70 Shore A</p> <p>Specification Water and oil resistant (up to 60 °C)</p> <p>Pack Quantity 10 pieces</p> <p>Specials electrostatically discharging on request</p> <p>Tip * also for bases with bolt down holes</p>
---	--

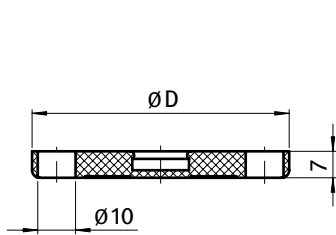

Anti-Slip-Platte Anti-slip Plate	D [mm]	für Teller for Base	Gewicht [g] Weight [g]	Teil-Nr. Part #
	20	30	2.0	098DG030
	30	40	4.0	098DG040
mit zentraler Durchgangsbohrung Ø 8,5 mm With central Ø 8.5 mm bore	30	40	4.0	098DG040B
	35	45	6.0	098DG045
	40	50	8.0	098DG050
	50	60	12.0	098DG060
	50	60*	12.0	098DG060B
	68	80	23.0	098DG080
	68	80*	23.0	098DG080B
	87	100*	37.0	098DG100B
	108	120*	60.0	098DG120B

Bodenelemente *Floor Elements*

Stellfüße *Leveling Feet*

Gelenkstellfüße Kugel 22 *Swivel Feet, Ball Joint 22*



ANTI-SLIP-PLATTE

ANTI-SLIP PLATE

<p>Ausführung für Gelenkstellfuß 60 mit Ausleger</p> <p>Beschreibung verhindert das Verrutschen von Stellfüßen auf glatten Industrieböden und kann Vibrationen dämpfen</p> <p>Material thermoplastisches Elastomer, ≈70 Shore A</p> <p>Farbe schwarz</p> <p>Eigenschaften beständig gegen Öl und Wasser (bis 60 °C)</p> <p>Liefereinheit 10 Stück</p> <p>Extras elektrostatisch entladend auf Anfrage</p>	<p>Model For extended base 60 for swivel feet</p> <p>Description Prevents movement of leveling feet on slippery surfaces and absorbs some vibration</p> <p>Material Thermoplastic elastomer, ≈70 Shore A</p> <p>Color Black</p> <p>Specification Water and oil resistant (up to 60 °C)</p> <p>Pack Quantity 10 pieces</p> <p>Specials electrostatically discharging on request</p>
---	--

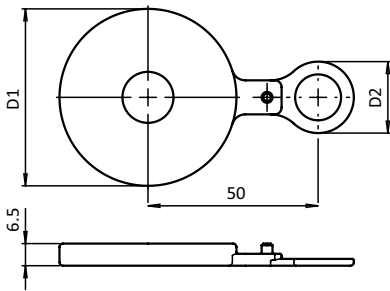

Anti-Slip-Platte <i>Anti-slip Plate</i>	D1 [mm]	D2 [mm]	für Teller <i>for Base</i>	Gewicht [g] <i>Weight [g]</i>	Teil-Nr. <i>Part #</i>
	52.0	21.0	60	13.0	098DAG060

Bodenelemente *Floor Elements*

Stellfüße *Leveling Feet*

Gelenkstellfüße Kugel 22 *Swivel Feet, Ball Joint 22*



ANTI-SLIP-PLATTE

ANTI-SLIP PLATE

<p>Ausführung für Gelenk-Quadrat-Stellfüße</p> <p>Beschreibung verhindert das Verrutschen von Stellfüßen auf glatten Industrieböden und kann Vibrationen dämpfen</p> <p>Material thermoplastisches Elastomer, ≈70 Shore A</p> <p>Eigenschaften beständig gegen Öl und Wasser (bis 60 °C)</p> <p>Liefereinheit 10 Stück</p> <p>Extras elektrostatisch entladend auf Anfrage</p>	<p>Model For square swivel feet</p> <p>Description Prevents movement of leveling feet on slippery surfaces and absorbs some vibration</p> <p>Material Thermoplastic elastomer, ≈70 Shore A</p> <p>Specification Water and oil resistant (up to 60 °C)</p> <p>Pack Quantity 10 pieces</p> <p>Specials electrostatically discharging on request</p>
---	--

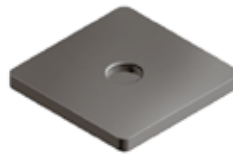
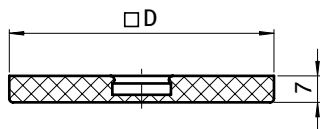

Anti-Slip-Platte <i>Anti-slip Plate</i>	D [mm]	für Teller <i>for Base</i>	Gewicht [g] <i>Weight [g]</i>	Teil-Nr. <i>Part #</i>
	50	60	26.0	098DVG060
	70	80	37.0	098DVG080
	89	100	47.0	098DVG100

1

Bodenelemente *Floor Elements*

Stellfüße *Leveling Feet*

Gelenkstellfüße Kugel 22 *Swivel Feet, Ball Joint 22*



ANTI-SLIP-PLATTE

ANTI-SLIP PLATE

<p>Ausführung für Schwerlastfüße</p> <p>Beschreibung verhindert das Verrutschen von Stellfüßen auf glatten Industrieböden und kann Vibrationen dämpfen</p> <p>Material thermoplastisches Elastomer, ≈70 Shore A</p> <p>Eigenschaften beständig gegen Öl und Wasser (bis 60 °C)</p> <p>Liefereinheit 10 Stück</p> <p>Extras elektrostatisch entladend auf Anfrage</p>	<p>Model For heavy-duty feet</p> <p>Description Prevents movement of leveling feet on slippery surfaces and absorbs some vibration</p> <p>Material Thermoplastic elastomer, ≈70 Shore A</p> <p>Specification Water and oil resistant (up to 60 °C)</p> <p>Pack Quantity 10 pieces</p> <p>Specials electrostatically discharging on request</p>
---	---

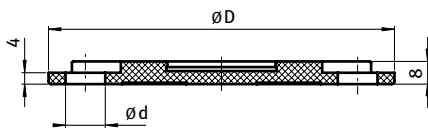

Anti-Slip-Platte <i>Anti-slip Plate</i>	D [mm]	für Teller <i>for Base</i>	Gewicht [g] <i>Weight [g]</i>	Teil-Nr. <i>Part #</i>
	122	125	88.0	098AG125B
	174	175	222.0	098AG175B



TELLER FÜR FESTE STELLFÜßE

BASE FOR PIVOT FEET

<p>Ausführung Kunststoff PA, ohne Anschraubbohrungen</p> <p>Beschreibung fester, nivellierbarer Stellfuß zum Ausgleich von Bodenunebenheiten</p> <p>Material Kunststoff PA, glaskugelverstärkt</p> <p>Farbe schwarz</p> <p>Liefereinheit 10 Stück</p> <p>Extras elektrostatisch entladend, weitere Größen, weitere Farben, angeschraubte oder geklebte Anti-Slip-Platte auf Anfrage; als montierter Stellfuß auf Anfrage</p> <p>Hinweis passende Gewindestange siehe Seite 56, passende Mutter siehe Seite 80 f., passende Anti-Slip Platte siehe Seite 60</p>	<p>Model Plastic PA, without bolt-down holes</p> <p>Description A leveling foot for strong positioning on slightly uneven floors</p> <p>Material Plastic PA, glass ball reinforced</p> <p>Color Black</p> <p>Pack Quantity 10 pieces</p> <p>Specials electrostatically discharging, other sizes, other colors, bolt-on or glued anti-slip plate on request; as factory assembled leveling foot on request</p> <p>Tip Compatible threaded rod see page 56, Compatible nut see page 80 et sq., Compatible anti-slip plate page 60</p>
--	---

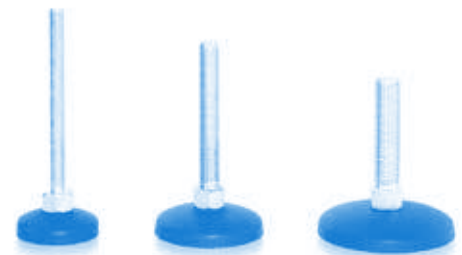
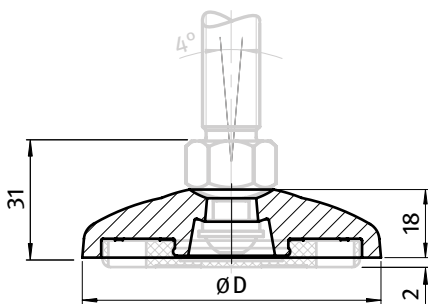

Teller Base	Teller für feste Stellfüße Base for Pivot Feet	D [mm]	Tragkraft [kg] Max. Load [kg]	Gewicht [g] Weight [g]	Teil-Nr. Part #
50	ohne Anti-Slip-Platte Without anti-slip plate	49	1200	16.5	098A050K
60	ohne Anti-Slip-Platte Without anti-slip plate	59	1200	27.0	098A060K
80	ohne Anti-Slip-Platte Without anti-slip plate	79	1200	52.0	098A080K
100	ohne Anti-Slip-Platte Without anti-slip plate	99	1200	84.0	098A100K
50	mit Anti-Slip-Platte With anti-slip plate	49	1200	23.0	098A050KG
60	mit Anti-Slip-Platte With anti-slip plate	59	1200	39.0	098A060KG
80	mit Anti-Slip-Platte With anti-slip plate	79	1200	75.0	098A080KG
100	mit Anti-Slip-Platte With anti-slip plate	99	1200	121.0	098A100KG

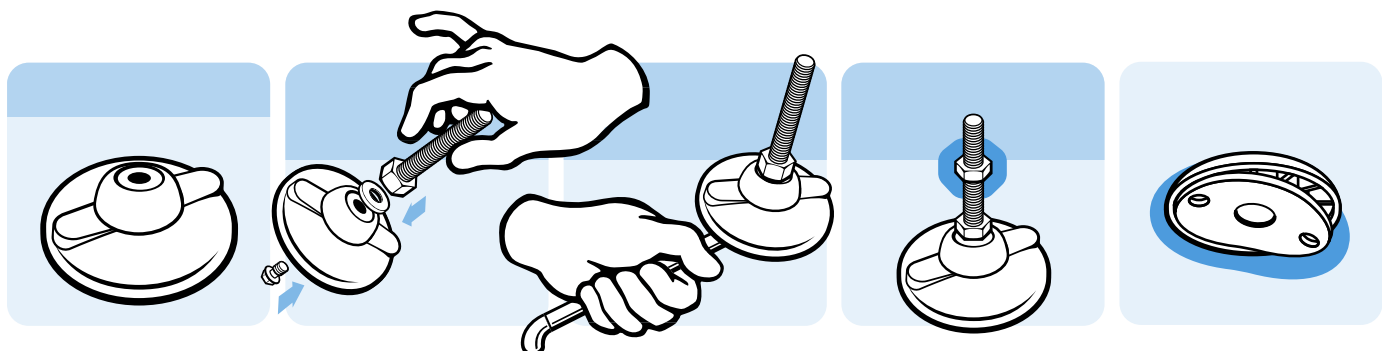

Bodenelemente *Floor Elements*

Stellfüße *Leveling Feet*

Feste Stellfüße *Pivot Feet*



TELLER FÜR FESTE STELLFÜßE

BASE FOR PIVOT FEET

Ausführung	Kunststoff PA, mit Anschraubbohrungen	Model	Plastic PA, with bolt-down holes
Beschreibung	fester, nivellierbarer Stellfuß zur Befestigung am Boden	Description	A leveling foot which can be fixed to the floor
Material	Kunststoff PA, glaskugelverstärkt	Material	Plastic PA, glass ball reinforced
Farbe	schwarz	Color	Black
Liefereinheit	10 Stück	Pack Quantity	10 pieces
Extras	☁elektrostatisch entladend, weitere Größen, weitere Farben, angeschraubte oder geklebte Anti-Slip-Platte auf Anfrage; als montierter Stellfuß auf Anfrage	Specials	☁electrostatically discharging, other sizes, other colors, bolt-on or glued anti-slip plate on request; as factory assembled leveling foot on request
Hinweis	passende Gewindestange siehe Seite 56, passende Mutter siehe Seite 80 f., passende Anti-Slip Platte siehe Seite 60; *Anschraubbohrungen geschlossen	Tip	Compatible threaded rod see page 56, Compatible nut see page 80 et sq., Compatible anti-slip plate page 60; *Bolt-down holes closed

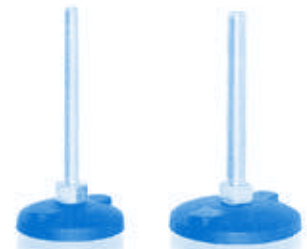
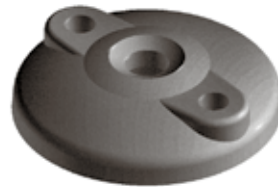
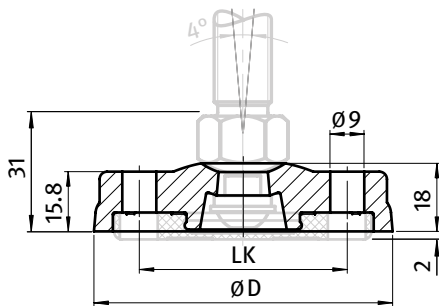

Teller Base	Teller für feste Stellfüße Base for Pivot Feet	D [mm]	LK [mm]	Tragkraft [kg] Max. Load [kg]	Gewicht [g] Weight [g]	Teil-Nr. Part #
80	ohne Anti-Slip-Platte Without anti-slip plate	79	55	1200	51.0	098A080KB
*80	ohne Anti-Slip-Platte Without anti-slip plate	79	55	1200	52.0	098A080KBZ
100	ohne Anti-Slip-Platte Without anti-slip plate	99	74	1200	85.0	098A100KB
*100	ohne Anti-Slip-Platte Without anti-slip plate	99	74	1200	87.0	098A100KBZ
80	mit Anti-Slip-Platte With anti-slip plate	79	55	1200	74.0	098A080KBG
*80	mit Anti-Slip-Platte With anti-slip plate	79	55	1200	75.0	098A080KBZG
100	mit Anti-Slip-Platte With anti-slip plate	99	74	1200	122.0	098A100KBG
*100	mit Anti-Slip-Platte With anti-slip plate	99	74	1200	124.0	098A100KBZG

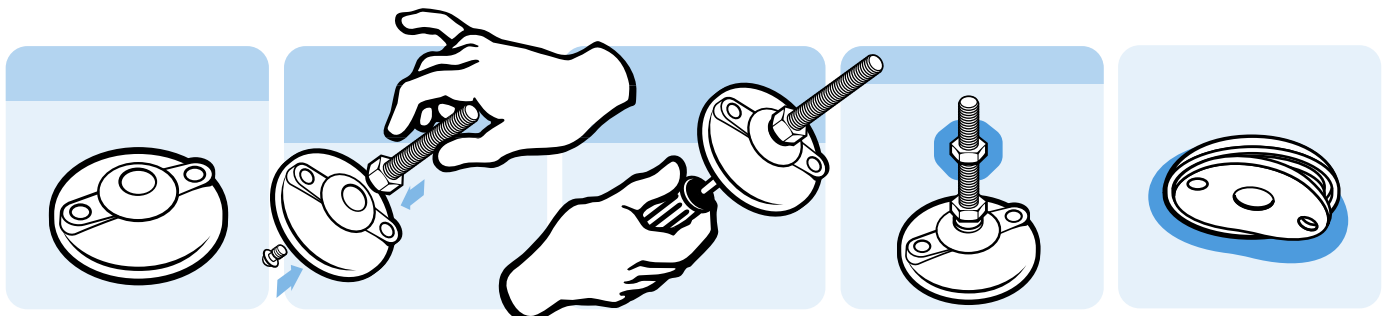

Bodenelemente Floor Elements

Stellfüße Leveling Feet

Feste Stellfüße Pivot Feet



TELLER FÜR FESTE STELLFÜßE

BASE FOR PIVOT FEET

Ausführung	Zinkdruckguss, ohne Anschraubbohrungen	Model	Zinc die-cast, without bolt-down holes
Beschreibung	fester, nivellierbarer Stellfuß zum Ausgleich von Bodenunebenheiten	Description	A leveling foot for strong positioning on slightly uneven floors
Material	Zinkdruckguss	Material	Zinc die-cast
Liefereinheit	10 Stück	Pack Quantity	10 pieces
Extras	weitere Oberflächen, weitere Größen, weitere Farben, angeschraubte oder geklebte Anti-Slip-Platte auf Anfrage; als montierter Stellfuß auf Anfrage	Specials	other surfaces, other sizes, other colors, bolt-on or glued anti-slip plate on request; as factory assembled leveling foot on request
Hinweis	passende Gewindestange siehe Seite 56, passende Mutter siehe Seite 80 f., passende Anti-Slip Platte siehe Seite 60	Tip	Compatible threaded rod see page 56, Compatible nut see page 80 et sq., Compatible anti-slip plate page 60

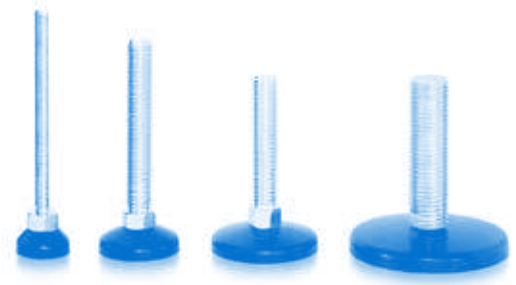
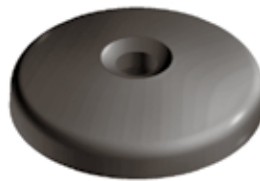
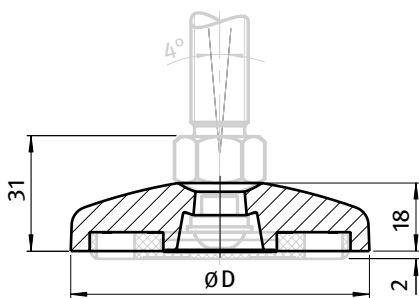

Teller Base	Teller für feste Stellfüße Base for Pivot Feet	D [mm]	Tragkraft [kg] Max. Load [kg]	Gewicht [g] Weight [g]	Teil-Nr. Part #
40	ohne Anti-Slip-Platte Without anti-slip plate	39	2000	86.0	098A040ZS
45	ohne Anti-Slip-Platte Without anti-slip plate	44	2500	110.0	098A045ZS
50	ohne Anti-Slip-Platte Without anti-slip plate	49	2500	112.0	098A050ZS
60	ohne Anti-Slip-Platte Without anti-slip plate	59	3500	157.0	098A060ZS
80	ohne Anti-Slip-Platte Without anti-slip plate	79	3500	300.0	098A080ZS
100	ohne Anti-Slip-Platte Without anti-slip plate	99	3500	387.0	098A100ZS
120	ohne Anti-Slip-Platte Without anti-slip plate	119	3500	620.0	098A120ZS
60	mit Anti-Slip-Platte With anti-slip plate	59	3500	169.0	098A060ZSG
80	mit Anti-Slip-Platte With anti-slip plate	79	3500	323.0	098A080ZSG
100	mit Anti-Slip-Platte With anti-slip plate	99	3500	424.0	098A100ZSG
120	mit Anti-Slip-Platte With anti-slip plate	119	3500	680.0	098A120ZSG

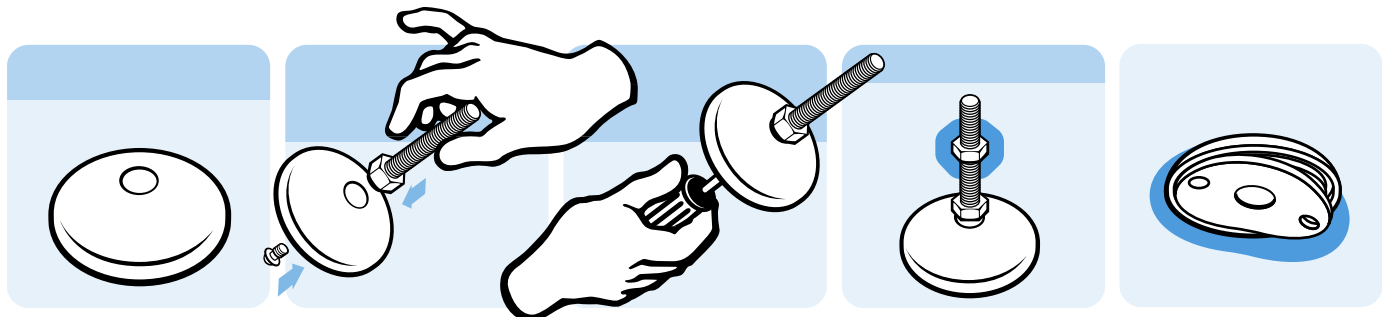

Bodenelemente *Floor Elements*

Stellfüße *Leveling Feet*

Feste Stellfüße *Pivot Feet*



TELLER FÜR FESTE STELLFÜßE

BASE FOR PIVOT FEET

Ausführung	Zinkdruckguss, mit Anschraubbohrungen	Model	Zinc die-cast, with bolt-down holes
Beschreibung	fester, nivellierbarer Stellfuß zur Befestigung am Boden	Description	A leveling foot which can be fixed to the floor
Material	Zinkdruckguss	Material	Zinc die-cast
Liefereinheit	10 Stück	Pack Quantity	10 pieces
Extras	weitere Oberflächen, weitere Größen, weitere Farben, angeschraubte oder geklebte Anti-Slip-Platte auf Anfrage; als montierter Stellfuß auf Anfrage	Specials	other surfaces, other sizes, other colors, bolt-on or glued anti-slip plate on request; as factory assembled leveling foot on request
Hinweis	passende Gewindestange siehe Seite 56, passende Mutter siehe Seite 80 f., passende Anti-Slip Platte siehe Seite 60	Tip	Compatible threaded rod see page 56, Compatible nut see page 80 et sq., Compatible anti-slip plate page 60

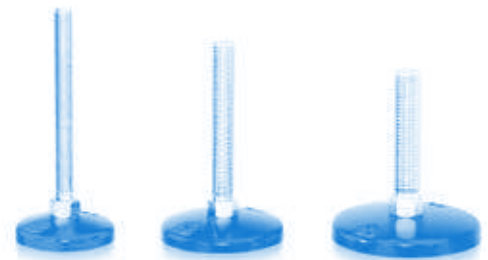
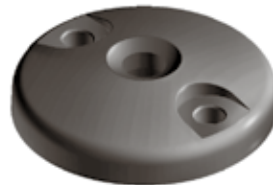
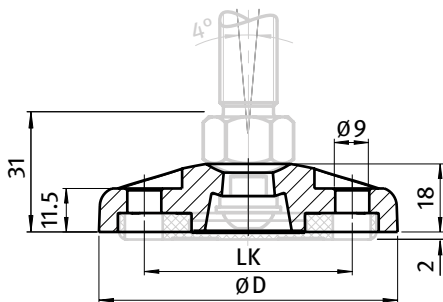

Teller Base	Teller für feste Stellfüße Base for Pivot Feet	D [mm]	LK [mm]	Tragkraft [kg] Max. Load [kg]	Gewicht [g] Weight [g]	Teil-Nr. Part #
60	ohne Anti-Slip-Platte Without anti-slip plate	59	40	3000	157.0	098A060ZBS
80	ohne Anti-Slip-Platte Without anti-slip plate	79	55	3500	256.0	098A080ZBS
100	ohne Anti-Slip-Platte Without anti-slip plate	99	74	3500	277.0	098A100ZBS
120	ohne Anti-Slip-Platte Without anti-slip plate	119	94	3500	580.0	098A120ZBS
60	mit Anti-Slip-Platte With anti-slip plate	59	40	3000	169.0	098A060ZBSG
80	mit Anti-Slip-Platte With anti-slip plate	79	55	3500	279.0	098A080ZBSG
100	mit Anti-Slip-Platte With anti-slip plate	99	74	3500	314.0	098A100ZBSG
120	mit Anti-Slip-Platte With anti-slip plate	119	94	3500	640.0	098A120ZBSG

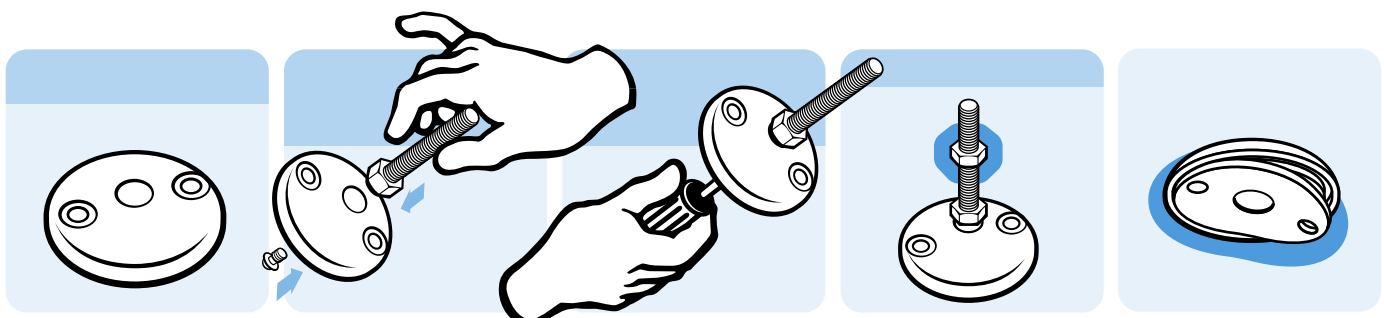

Bodenelemente Floor Elements

Stellfüße Leveling Feet

Feste Stellfüße Pivot Feet



TELLER FÜR FESTE STELLFÜßE

BASE FOR PIVOT FEET

Ausführung	Edelstahl, ohne Anschraubbohrungen	Model	Stainless steel, without bolt-down holes
Beschreibung	fester, nivellierbarer Stellfuß zum Ausgleich von Bodenunebenheiten	Description	A leveling foot for strong positioning on slightly uneven floors
Material	Edelstahl 1.4305	Material	Stainless steel SS303
Liefereinheit	10 Stück	Pack Quantity	10 pieces
Extras	weitere Größen, geklebte Anti-Slip-Platte auf Anfrage; als montierter Stellfuß auf Anfrage	Specials	Other sizes, glued anti-slip plate on request; as factory assembled leveling foot on request
Hinweis	passende Gewindestange siehe Seite 56, passende Mutter siehe Seite 80 f., passende Anti-Slip Platte siehe Seite 60	Tip	Compatible threaded rod see page 56, Compatible nut see page 80 et sq., Compatible anti-slip plate page 60

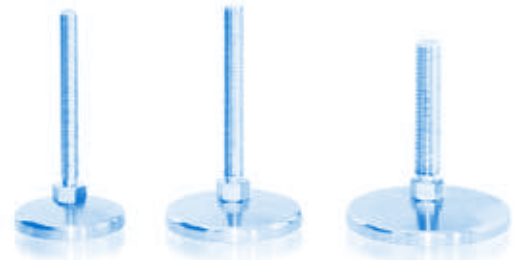
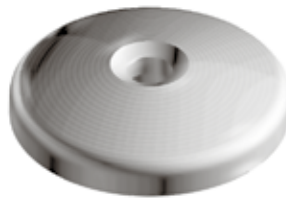
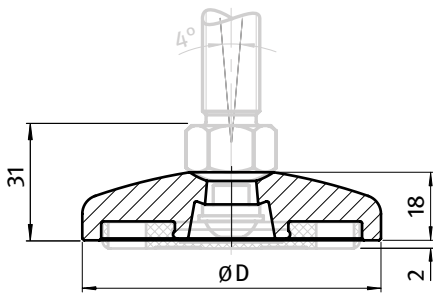

Teller Base	Teller für feste Stellfüße Base for Pivot Feet	D [mm]	Tragkraft [kg] Max. Load [kg]	Gewicht [g] Weight [g]	Teil-Nr. Part #
60	ohne Anti-Slip-Platte Without anti-slip plate	59	4500	216.0	098A060E
80	ohne Anti-Slip-Platte Without anti-slip plate	79	4500	377.0	098A080E
100	ohne Anti-Slip-Platte Without anti-slip plate	99	4500	640.0	098A100E
120	ohne Anti-Slip-Platte Without anti-slip plate	119	4500	850.0	098A120E
60	mit Anti-Slip-Platte With anti-slip plate	59	4500	228.0	098A060EG
80	mit Anti-Slip-Platte With anti-slip plate	79	4500	400.0	098A080EG
100	mit Anti-Slip-Platte With anti-slip plate	99	4500	677.0	098A100EG
120	mit Anti-Slip-Platte With anti-slip plate	119	4500	910.0	098A120EG

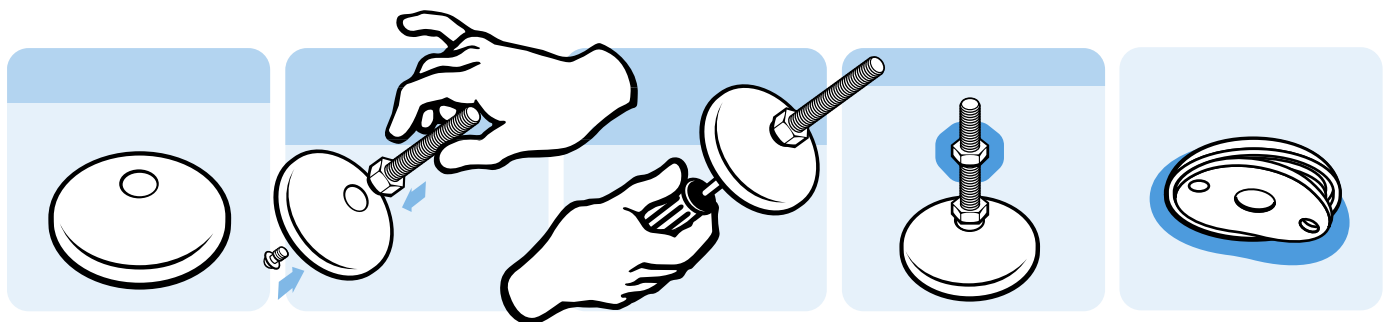

Bodenelemente *Floor Elements*

Stellfüße *Leveling Feet*

Feste Stellfüße *Pivot Feet*



TELLER FÜR FESTE STELLFÜßE

BASE FOR PIVOT FEET

Ausführung	Edelstahl, mit Anschraubbohrungen	Model	Stainless steel, with bolt-down holes
Beschreibung	fester, nivellierbarer Stellfuß zur Befestigung am Boden	Description	A leveling foot which can be fixed to the floor
Material	Edelstahl 1.4305	Material	Stainless steel SS303
Liefereinheit	10 Stück	Pack Quantity	10 pieces
Extras	weitere Größen, geklebte Anti-Slip-Platte auf Anfrage; als montierter Stellfuß auf Anfrage	Specials	Other sizes, glued anti-slip plate on request; as factory assembled leveling foot on request
Hinweis	passende Gewindestange siehe Seite 56, passende Mutter siehe Seite 80 f., passende Anti-Slip Platte siehe Seite 60	Tip	Compatible threaded rod see page 56, Compatible nut see page 80 et sq., Compatible anti-slip plate page 60

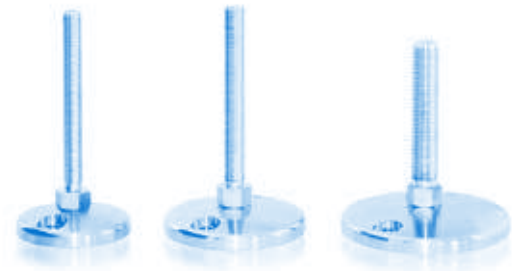
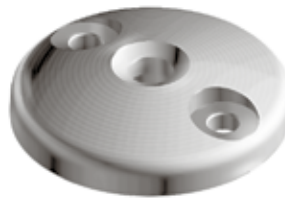
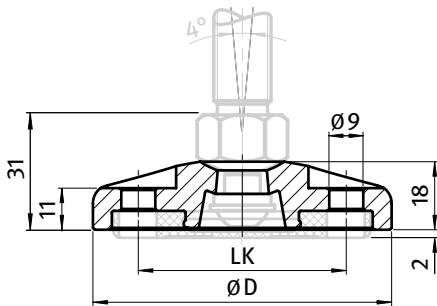

Teller Base	Teller für feste Stellfüße Base for Pivot Feet	D [mm]	LK [mm]	Tragkraft [kg] Max. Load [kg]	Gewicht [g] Weight [g]	Teil-Nr. Part #
80	ohne Anti-Slip-Platte Without anti-slip plate	79	55	3000	355.0	098A080EB
100	ohne Anti-Slip-Platte Without anti-slip plate	99	74	3500	828.0	098A100EB
120	ohne Anti-Slip-Platte Without anti-slip plate	119	94	3500	840.0	098A120EB
80	mit Anti-Slip-Platte With anti-slip plate	79	55	3000	378.0	098A080EBG
100	mit Anti-Slip-Platte With anti-slip plate	99	74	3500	865.0	098A100EBG
120	mit Anti-Slip-Platte With anti-slip plate	119	94	3500	900.0	098A120EBG

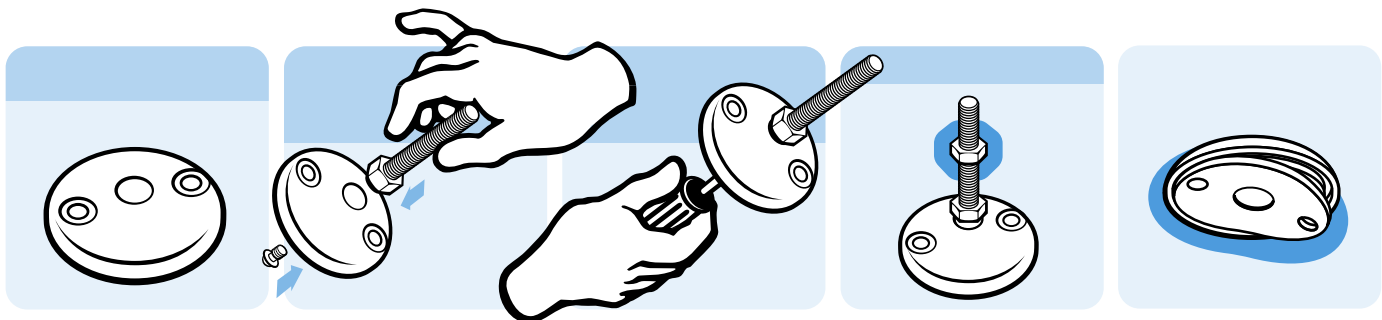

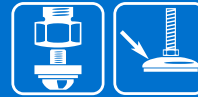

TRAPEZTELLER FÜR FESTE STELLFÜßE

TRAPEZOID BASE FOR PIVOT FEET

Ausführung Zinkdruckguss
Beschreibung fester, nivellierbarer Stellfuß zum Ausgleich von Bodenunebenheiten
Material Zinkdruckguss
Liefereinheit 10 Stück
Extras weitere Größen, geklebte Anti-Slip-Platte auf Anfrage; als montierter Stellfuß auf Anfrage
Hinweis passende Gewindestange siehe Seite 56, passende Mutter siehe Seite 80 f., passende Anti-Slip Platte siehe Seite 60

Model Zinc die-cast
Description A leveling foot for strong positioning on slightly uneven floors
Material Zinc die-cast
Pack Quantity 10 pieces
Specials Other sizes, glued anti-slip plate on request; as factory assembled leveling foot on request
Tip Compatible threaded rod see page 56, Compatible nut see page 80 et sq., Compatible anti-slip plate page 60

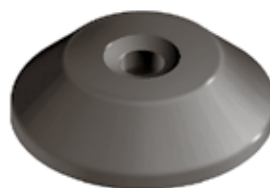
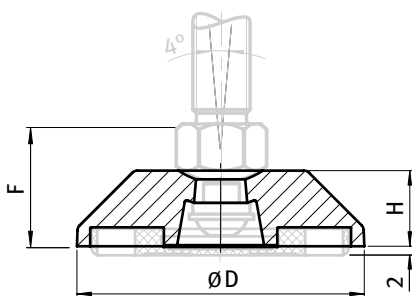

Teller Base	Trapezteller für feste Stellfüße Trapezoid Base for Pivot Feet	D [mm]	F [mm]	H [mm]	Tragkraft [kg] Max. Load [kg]	Gewicht [g] Weight [g]	Teil-Nr. Part #
60	ohne Anti-Slip-Platte Without anti-slip plate	59	31.0	18	2500	115.6	098AI060ZS
80	ohne Anti-Slip-Platte Without anti-slip plate	76	33.0	20	3000	201.3	098AI080ZS
60	mit Anti-Slip-Platte With anti-slip plate	59	31.0	18	2500	127.6	098AI060ZSG
80	mit Anti-Slip-Platte With anti-slip plate	76	33.0	20	3000	224.3	098AI080ZSG

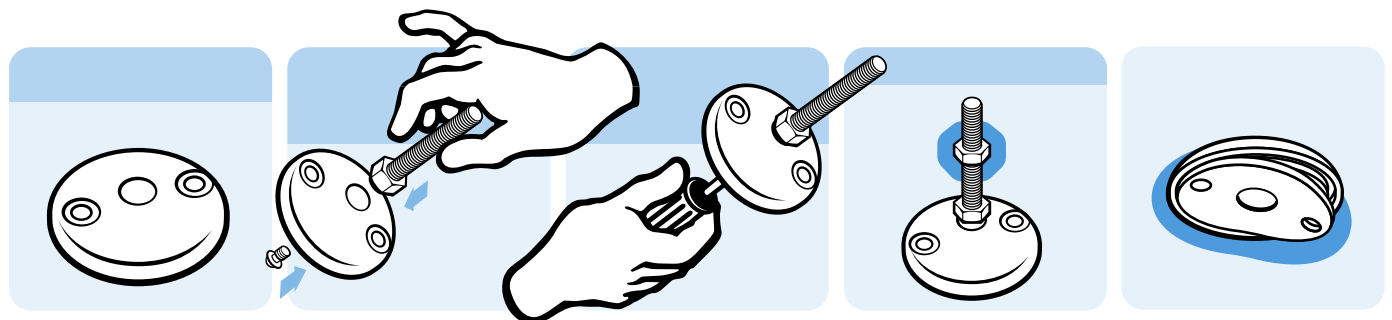

Bodenelemente *Floor Elements*

Stellfüße *Leveling Feet*

Feste Stellfüße *Pivot Feet*



TELLER 80 MIT AUSLEGER FÜR FESTE STELLFÜßE

EXTENDED BASE 80 FOR PIVOT FEET

<p>Ausführung Zinkdruckguss</p> <p>Beschreibung fester, nivellierbarer Stellfuß zur stabilen Befestigung am Boden</p> <p>Material Zinkdruckguss</p> <p>Liefereinheit 10 Stück</p> <p>Extras weitere Oberflächen, weitere Größen, weitere Farben, angeschraubte oder geklebte Anti-Slip-Platte auf Anfrage; als montierter Stellfuß auf Anfrage</p> <p>Hinweis passende Gewindestange siehe Seite 56, passende Mutter siehe Seite 80 f., passende Anti-Slip Platte siehe Seite 60</p>	<p>Model Zinc die-cast</p> <p>Description Extended leveling foot which can be fixed to the floor</p> <p>Material Zinc die-cast</p> <p>Pack Quantity 10 pieces</p> <p>Specials Other surfaces, other sizes, other colors, screwed or glued anti-slip plate on request; as factory assembled leveling foot on request</p> <p>Tip Compatible threaded rod see page 56, Compatible nut see page 80 et sq., Compatible anti-slip plate page 60</p>
--	---

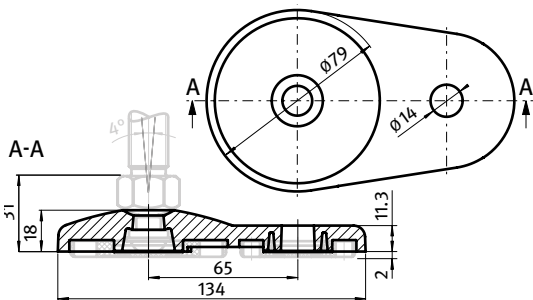

Teller Base	Teller 80 mit Ausleger für feste Stellfüße Extended Base 80 for Pivot Feet	Tragkraft [kg] Max. Load [kg]	Gewicht [g] Weight [g]	Teil-Nr. Part #
80	ohne Anti-Slip-Platte <i>Without anti-slip plate</i>	3500	400.0	098AA080ZS
80	mit Anti-Slip-Platte <i>With anti-slip plate</i>	3500	423.0	098AA080ZSG

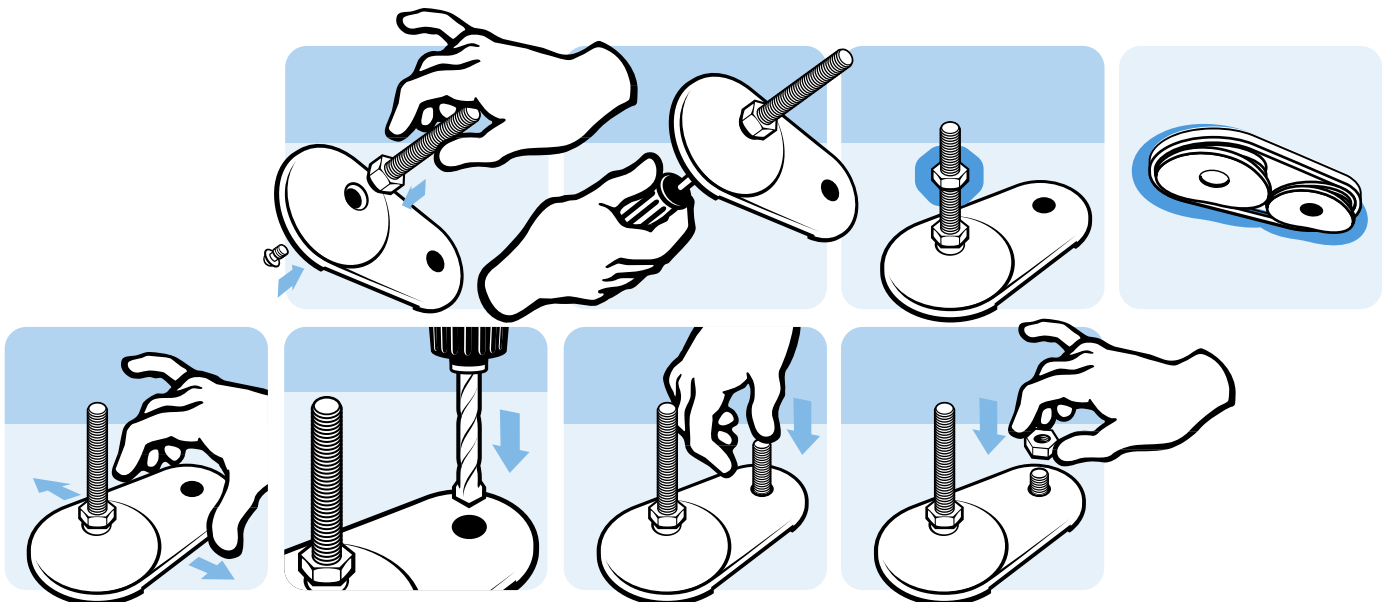

Bodenelemente Floor Elements

Stellfüße Leveling Feet

Feste Stellfüße Pivot Feet



QUADRATTELLER FÜR FESTE STELLFÜÙE

SQUARE BASE FOR PIVOT FEET

Ausführung	Zinkdruckguss	Model	Zinc die-cast
Beschreibung	fester, nivellierbarer Stellfuß zum Ausgleich von Bodenunebenheiten	Description	A leveling foot for strong positioning on slightly uneven floors
Material	Zinkdruckguss	Material	Zinc die-cast
Liefereinheit	10 Stück	Pack Quantity	10 pieces
Extras	weitere Oberflächen, weitere Größen, weitere Farben, Anschraubbohrungen, angeschraubte oder geklebte Anti-Slip-Platte auf Anfrage; als montierter Stellfuß auf Anfrage	Specials	Other surfaces, other sizes, other colors, bolt down holes, screwed or glued anti-slip plate on request; as factory assembled leveling foot on request
Hinweis	passende Gewindestange siehe Seite 56, passende Mutter siehe Seite 80 f., passende Anti-Slip Platte siehe Seite 61	Tip	Compatible threaded rod see page 56, Compatible nut see page 80 et sq., Compatible anti-slip plate page 61

1

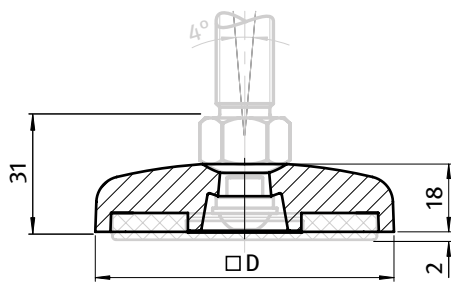

Quadratteller für feste StellfüÙe
Square Base for Pivot Feet

	Teller Base	D [mm]	Tragkraft [kg] Max. Load [kg]	Gewicht [g] Weight [g]	Teil-Nr. Part #
ohne Anti-Slip-Platte Without anti-slip plate	60	59 × 59	2500	174.0	098AV060ZS
	80	79 × 79	3000	321.0	098AV080ZS
	100	99 × 99	3500	482.0	098AV100ZS
mit Anti-Slip-Platte With anti-slip plate	60	59 × 59	2500	186.0	098AV060ZSG
	80	79 × 79	3000	344.0	098AV080ZSG
	100	99 × 99	3500	519.0	098AV100ZSG

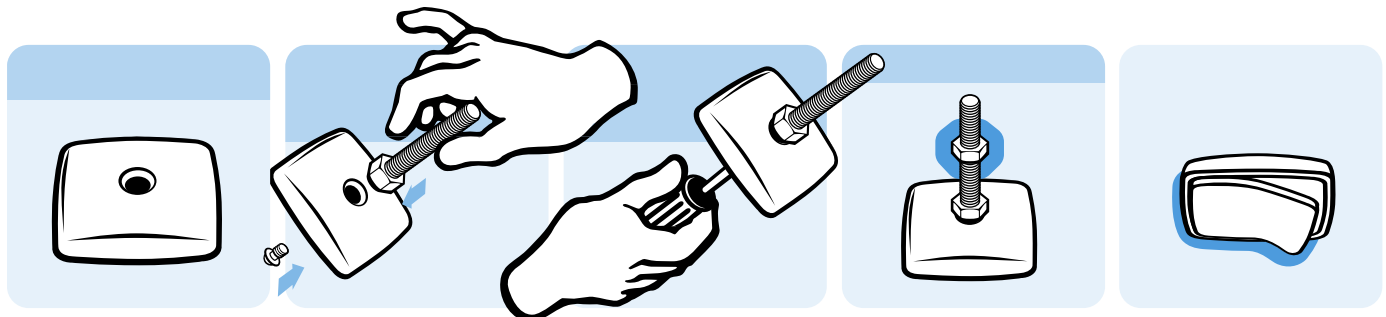

Bodenelemente *Floor Elements*

Stellfüße *Leveling Feet*

Feste Stellfüße *Pivot Feet*



TELLER FÜR FESTE SCHWERLASTFÜßE

BASE FOR HEAVY-DUTY PIVOT FEET

<p>Ausführung Kunststoff PA, mit Anschraubbohrungen</p> <p>Beschreibung fester, nivellierbarer Stellfuß für schwere Maschinen</p> <p>Material Kunststoff PA, glaskugelverstärkt</p> <p>Farbe schwarz</p> <p>Liefereinheit 1 Stück</p> <p>Extras elektrostatisch entladend, weitere Größen, weitere Farben, angeschraubte oder geklebte Anti-Slip-Platte auf Anfrage; als montierter Stellfuß auf Anfrage</p> <p>Hinweis passende Gewindestange siehe Seite 56, passende Mutter siehe Seite 80 f., passende Anti-Slip Platte siehe Seite 44</p>	<p>Model Plastic PA, with Bolt-down Holes</p> <p>Description A heavy-duty leveling foot for strong positioning on slightly uneven floors</p> <p>Material Plastic PA, glass ball reinforced</p> <p>Color Black</p> <p>Pack Quantity 1 piece</p> <p>Specials electrostatically discharging, other sizes, other colors, bolt-on or glued anti-slip plate on request; as factory assembled leveling foot on request</p> <p>Tip Compatible threaded rod see page 56, Compatible nut see page 80 et sq., Compatible anti-slip plate page 44</p>
--	---

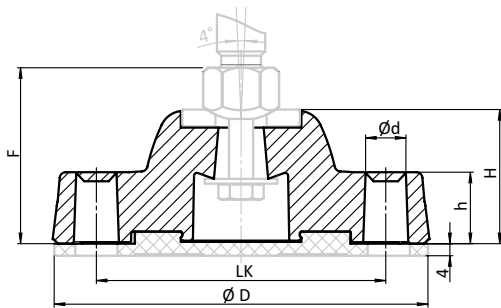

Teller Base	Teller für feste Schwerlastfüße Base for Heavy-duty Pivot Feet	D [mm]	F [mm]	H [mm]	LK [mm]	Tragkraft [kg] Max. Load [kg]	Gewicht [g] Weight [g]	Teil-Nr. Part #
125	ohne Anti-Slip-Platte Without anti-slip plate	125	57.5	44	96	1800	234.0	098AK125KBZ
175	ohne Anti-Slip-Platte Without anti-slip plate	175	58.5	45	135	2500	344.0	098AK175KBZ
125	mit Anti-Slip-Platte With anti-slip plate	125	57.5	44	96	1800	322.0	098AK125KBZG
175	mit Anti-Slip-Platte With anti-slip plate	175	58.5	45	135	2500	566.0	098AK175KBZG

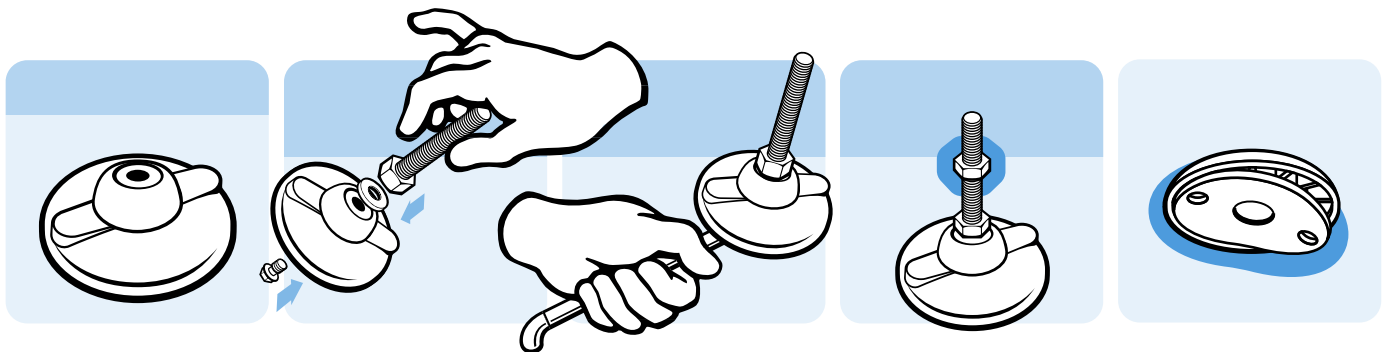



BODENBEFESTIGUNG

FLOOR MOUNTING

Ausführung	für Trapezsteller	Model	For trapezoid base
Beschreibung	zur sicheren Befestigung des Trapezstellfußes am Boden, nachträgliche Montage möglich	Description	To securely fix the trapezoid leveling foot to the floor - can be mounted subsequently
Material	Zinkdruckguss	Material	Zinc die-cast
Liefereinheit	10 Stück	Pack Quantity	10 pieces
Hinweis	passende Trapezsteller siehe Seite 27 und Seite 51	Tip	Compatible trapezoid base see page 27 and page 51

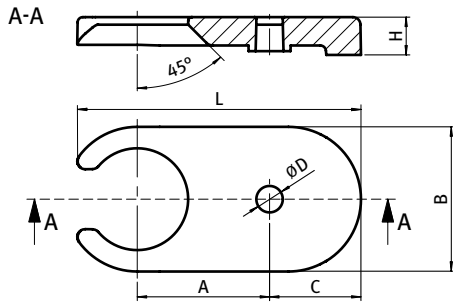

Bodenbefestigung für Teller <i>Floor Mounting for Base</i>	A [mm]	B [mm]	C [mm]	D [mm]	H [mm]	L [mm]	Gewicht [g] <i>Weight [g]</i>	Profil <i>Profile</i>	Teil-Nr. <i>Part #</i>
60	50.0	56.0	38.0	12.0	18.0	110.0	240.5	I	098BI060ZS
80	70.0	76.5	48.0	14.0	20.0	150.0	502.4	I	098BI080ZS

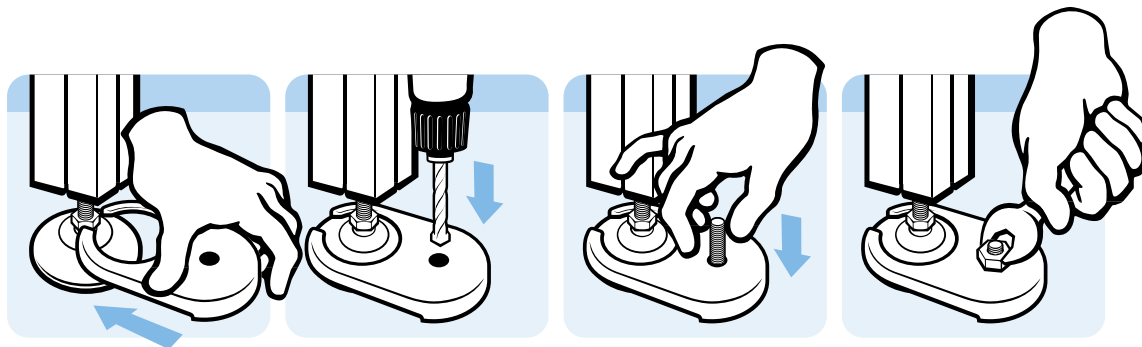

Bodenelemente *Floor Elements*

Stellfüße *Leveling Feet*

Feste Stellfüße *Pivot Feet*



GEWINDESTANGE FÜR FESTE STELLFÜÙE

THREADED ROD FOR PIVOT FEET

Ausführung	Stahl	Model	Steel
Beschreibung	Gewindestange für feste, nivellierbare StellfüÙe	Description	Threaded rod for pivot leveling feet
Material	Stahl, verzinkt	Material	Steel, zinc plated
Verbindung	Schwenkbereich ±4°	Screw joint	Swiveling range ±4°
Liefereinheit	10 Stück	Pack Quantity	10 pieces
Extras	weitere Längen und Größen auf Anfrage	Specials	Other lengths and sizes on request
Hinweis	*1. für feste StellfüÙe: Lieferung inkl. Montagesatz 098XAMS03 *2. für feste SchwerlastfüÙe: Lieferung inkl. Montagesatz 098XAKM	Tip	*1. For pivot feet: Assembly set 098XAMS03 included *2. For heavy-duty pivot feet: Assembly set 098XAKM included

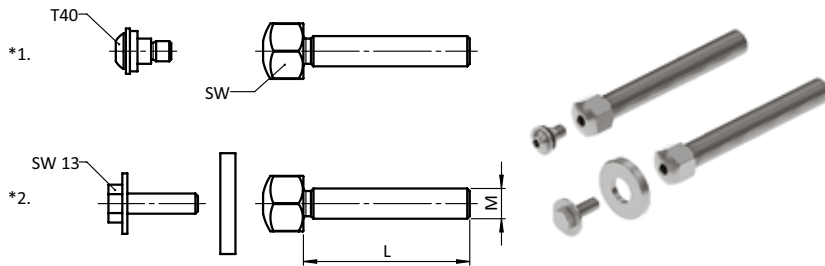

Gewindestange für feste StellfüÙe <i>Threaded Rod for Pivot Feet</i>	M × L [mm]	SW [mm]	Tragkraft [kg] <i>Max. Load [kg]</i>	Gewicht [g] <i>Weight [g]</i>	Teil-Nr. <i>Part #</i>
Stahl, verzinkt <i>Steel, zinc plated</i>	M12 × 66	22	770	70.0	098AM12066M
	M12 × 100	22	770	94.0	098AM12100M
	M12 × 125	22	770	127.0	098AM12125M
	M12 × 150	22	770	130.0	098AM12150M
	M16 × 66	22	1450	112.0	098AM16066M
	M16 × 100	22	1450	152.0	098AM16100M
	M16 × 125	22	1450	173.0	098AM16125M
	M16 × 150	22	1450	235.0	098AM16150M
	M16 × 200	22	1450	315.0	098AM16200M
	M16 × 250	22	1450	394.0	098AM16250M
	M20 × 100	22	2430	237.0	098AM20100M
	M20 × 125	22	2430	255.0	098AM20125M
	M20 × 150	22	2430	341.0	098AM20150M
	M20 × 200	22	2430	447.0	098AM20200M
	M20 × 250	22	2430	542.0	098AM20250M
	M24 × 100	24	3610	342.0	098AM24100M
	M24 × 150	24	3610	477.0	098AM24150M
	M24 × 200	24	3610	631.0	098AM24200M
	M24 × 300	24	3610	947.0	098AM24300M
	M30 × 100	24	5770	512.0	098AM30100M
	M30 × 150	24	5770	744.0	098AM30150M
	M30 × 200	24	5770	976.0	098AM30200M
	M30 × 250	24	5770	1115.0	098AM30250M
	M30 × 300	24	5770	1420.0	098AM30300M



GEWINDESTANGE FÜR FESTE STELLFÜßE

THREADED ROD FOR PIVOT FEET

Ausführung	Edelstahl	Model	Stainless Steel
Beschreibung	Gewindestange für feste, nivellierbare Stellfüße	Description	Threaded rod for pivot leveling feet
Material	Edelstahl 1.4306	Material	Stainless steel SS309
Verbindung	Schwenkbereich ±4°	Screw joint	Swiveling range ±4°
Liefereinheit	10 Stück	Pack Quantity	10 pieces
Extras	weitere Längen und Größen auf Anfrage	Specials	Other lengths and sizes on request
Hinweis	*1. für feste Stellfüße: Lieferung inkl. Montagesatz 098XAES03 *2. für feste Schwerlastfüße: Lieferung inkl. Montagesatz 098XAKE	Tip	*1. For pivot feet: Assembly set 098XAES03 included *2. For heavy-duty pivot feet: Assembly set or 098XAKE included

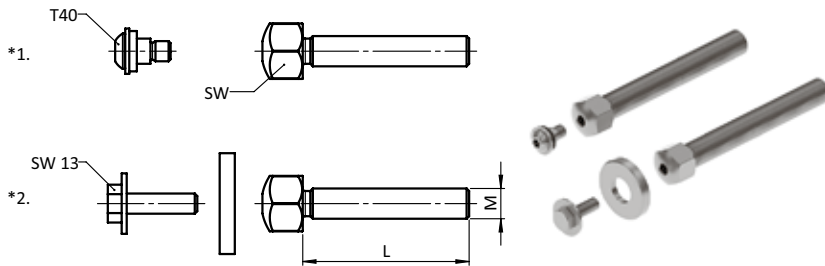

Gewindestange für feste Stellfüße Threaded Rod for Pivot Feet	M × L [mm]	SW [mm]	Tragkraft [kg] Max. Load [kg]	Gewicht [g] Weight [g]	Teil-Nr. Part #
Edelstahl <i>Stainless steel</i>	M12 × 66	22	770	70.0	098AM12066E
	M12 × 100	22	770	94.0	098AM12100E
	M12 × 125	22	770	127.0	098AM12125E
	M12 × 150	22	770	130.0	098AM12150E
	M16 × 66	22	1450	112.0	098AM16066E
	M16 × 100	22	1450	152.0	098AM16100E
	M16 × 125	22	1450	173.0	098AM16125E
	M16 × 150	22	1450	235.0	098AM16150E
	M16 × 200	22	1450	315.0	098AM16200E
	M16 × 250	22	1450	394.0	098AM16250E
	M20 × 100	22	2430	237.0	098AM20100E
	M20 × 125	22	2430	255.0	098AM20125E
	M20 × 150	22	2430	341.0	098AM20150E
	M20 × 200	22	2430	447.0	098AM20200E
	M20 × 250	22	2430	542.0	098AM20250E
	M24 × 100	24	3610	342.0	098AM24100E
	M24 × 150	24	3610	477.0	098AM24150E
	M24 × 200	24	3610	631.0	098AM24200E
	M24 × 300	24	3610	947.0	098AM24300E
	M30 × 100	24	5770	512.0	098AM30100E
	M30 × 150	24	5770	744.0	098AM30150E
	M30 × 200	24	5770	976.0	098AM30200E
	M30 × 250	24	5770	1115.0	098AM30250E
	M30 × 300	24	5770	1420.0	098AM30300E

Bodenelemente *Floor Elements*

Stellfüße *Leveling Feet*

Feste Stellfüße *Pivot Feet*



UNC-GEWINDESTANGE FÜR FESTE STELLFÜßE

UNC THREADED ROD FOR PIVOT FEET

Ausführung	Stahl	Model	Steel
Beschreibung	Gewindestange für feste, nivellierbare Stellfüße	Description	Threaded rod for pivot leveling feet
Material	Stahl, verzinkt	Material	Steel, zinc plated
Verbindung	Schwenkbereich ±4°	Screw joint	Swiveling range ±4°
Liefereinheit	10 Stück	Pack Quantity	10 pieces
Extras	weitere Längen und Größen auf Anfrage	Specials	Other lengths and sizes on request
Hinweis	*1. für feste Stellfüße: Lieferung inkl. Montagesatz 098XAMS03 *2. für feste Schwerlastfüße: Lieferung inkl. Montagesatz 098XAUM	Tip	*2. For pivot feet: Assembly set 098XAMS03 included *2. For heavy-duty pivot feet: Assembly set 098XAUM included

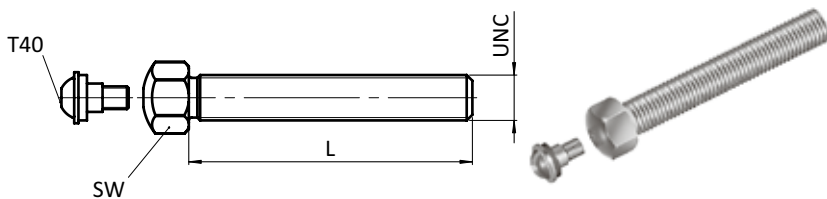

UNC-Gewindestange für feste Stellfüße <i>UNC Threaded Rod for Pivot Feet</i>	SW [mm]	UNC × L [in]	Tragkraft [kg] <i>Max. Load [kg]</i>	Gewicht [g] <i>Weight [g]</i>	Teil-Nr. <i>Part #</i>
Stahl, verzinkt <i>Steel, zinc plated</i>	22 - 7/8"	1/2-13 UNC × 3"	770	108.0	098AU1/2-3M
	22 - 7/8"	1/2-13 UNC × 4"	770	128.0	098AU1/2-4M
	22 - 7/8"	1/2-13 UNC × 5"	770	147.0	098AU1/2-5M
	22 - 7/8"	1/2-13 UNC × 6"	770	168.0	098AU1/2-6M
	22 - 7/8"	5/8-11 UNC × 3"	1450	121.0	098AU5/8-3M
	22 - 7/8"	5/8-11 UNC × 4"	1450	149.0	098AU5/8-4M
	22 - 7/8"	5/8-11 UNC × 5"	1450	207.0	098AU5/8-5M
	22 - 7/8"	5/8-11 UNC × 6"	1450	239.0	098AU5/8-6M
	22 - 7/8"	5/8-11 UNC × 8"	1450	303.0	098AU5/8-8M
	22 - 7/8"	3/4-10 UNC × 4"	2430	239.0	098AU3/4-4M
	22 - 7/8"	3/4-10 UNC × 5"	2430	281.0	098AU3/4-5M
	22 - 7/8"	3/4-10 UNC × 6"	2430	328.0	098AU3/4-6M
	22 - 7/8"	3/4-10 UNC × 8"	2430	424.0	098AU3/4-8M
	22 - 7/8"	1-8 UNC × 4"	3610	342.0	098AU1-4M
	22 - 7/8"	1-8 UNC × 6"	3610	478.0	098AU1-6M
	22 - 7/8"	1-8 UNC × 8"	3610	631.0	098AU1-8M

Bodenelemente *Floor Elements*

Stellfüße *Leveling Feet*

Feste Stellfüße *Pivot Feet*



UNC-GEWINDESTANGE FÜR FESTE STELLFÜßE

UNC THREADED ROD FOR PIVOT FEET

Ausführung	Edelstahl	Model	Stainless Steel
Beschreibung	Gewindestange für feste, nivellierbare Stellfüße	Description	Threaded rod for pivot leveling feet
Material	Edelstahl 1.4306	Material	Stainless steel SS309
Verbindung	Schwenkbereich ±4°	Screw joint	Swiveling range ±4°
Liefereinheit	10 Stück	Pack Quantity	10 pieces
Extras	weitere Längen und Größen auf Anfrage	Specials	Other lengths and sizes on request
Hinweis	*1. für feste Stellfüße: Lieferung inkl. Montagesatz 098XAES03 *2. für feste Schwerlastfüße: Lieferung inkl. Montagesatz 098XAUE	Tip	*2. For pivot feet: Assembly set 098XAES03 included *2. For heavy-duty pivot feet: Assembly set 098XAUE included

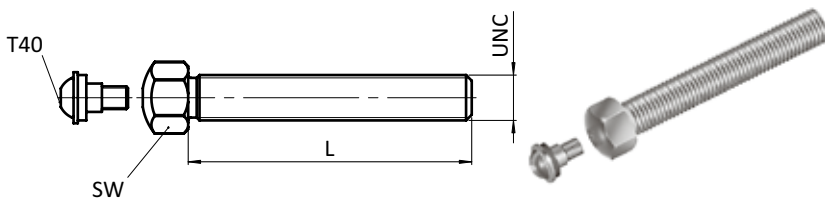

UNC-Gewindestange für feste Stellfüße <i>UNC Threaded Rod for Pivot Feet</i>	SW [mm]	UNC x L [in]	Tragkraft [kg] <i>Max. Load [kg]</i>	Gewicht [g] <i>Weight [g]</i>	Teil-Nr. <i>Part #</i>
Edelstahl <i>Stainless steel</i>	22 - 7/8"	1/2-13 UNC x 3"	770	108.0	098AU1/2-3E
	22 - 7/8"	1/2-13 UNC x 4"	770	128.0	098AU1/2-4E
	22 - 7/8"	1/2-13 UNC x 5"	770	147.0	098AU1/2-5E
	22 - 7/8"	1/2-13 UNC x 6"	770	168.0	098AU1/2-6E
	22 - 7/8"	5/8-11 UNC x 3"	1450	121.0	098AU5/8-3E
	22 - 7/8"	5/8-11 UNC x 4"	1450	149.0	098AU5/8-4E
	22 - 7/8"	5/8-11 UNC x 5"	1450	207.0	098AU5/8-5E
	22 - 7/8"	5/8-11 UNC x 6"	1450	239.0	098AU5/8-6E
	22 - 7/8"	5/8-11 UNC x 8"	1450	303.0	098AU5/8-8E
	22 - 7/8"	3/4-10 UNC x 4"	2430	239.0	098AU3/4-4E
	22 - 7/8"	3/4-10 UNC x 5"	2430	281.0	098AU3/4-5E
	22 - 7/8"	3/4-10 UNC x 6"	2430	328.0	098AU3/4-6E
	22 - 7/8"	3/4-10 UNC x 8"	2430	424.0	098AU3/4-8E
	22 - 7/8"	1-8 UNC x 4"	3610	342.0	098AU1-4E
	22 - 7/8"	1-8 UNC x 6"	3610	478.0	098AU1-6E
	22 - 7/8"	1-8 UNC x 8"	3610	631.0	098AU1-8E
	22 - 7/8"	1 1/4-7 UNC x 4"	5770	512.0	098AU11/4-4E
	22 - 7/8"	1 1/4-7 UNC x 6"	5770	744.0	098AU11/4-6E
	22 - 7/8"	1 1/4-7 UNC x 8"	5770	977.0	098AU11/4-8E

Bodenelemente *Floor Elements*

Stellfüße *Leveling Feet*

Feste Stellfüße *Pivot Feet*



ANTI-SLIP-PLATTE

ANTI-SLIP PLATE

<p>Ausführung für feste Stellfüße</p> <p>Beschreibung verhindert das Verrutschen von Stellfüßen auf glatten Industrieböden und kann Vibrationen dämpfen</p> <p>Material thermoplastisches Elastomer, ≈70 Shore A</p> <p>Eigenschaften beständig gegen Öl und Wasser (bis 60 °C)</p> <p>Liefereinheit 10 Stück</p> <p>Extras ⚡ elektrostatisch entladend auf Anfrage</p> <p>Hinweis *auch für Teller mit Anschraubbohrungen</p>	<p>Model For pivot feet</p> <p>Description Prevents movement of leveling feet on slippery surfaces and absorbs some vibration</p> <p>Material Thermoplastic elastomer, ≈70 Shore A</p> <p>Specification Water and oil resistant (up to 60 °C)</p> <p>Pack Quantity 10 pieces</p> <p>Specials ⚡ electrostatically discharging on request</p> <p>Tip *also for bases with bolt down holes</p>
---	--

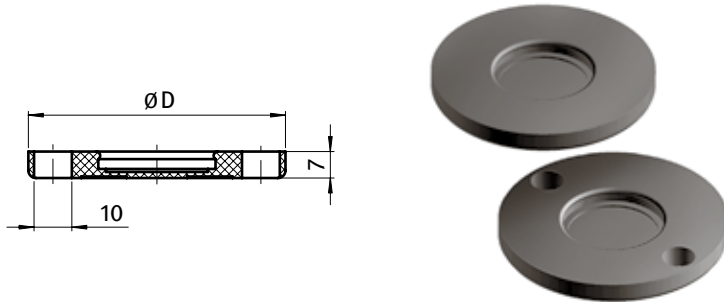

Anti-Slip-Platte <i>Anti-slip Plate</i>	D [mm]	für Teller <i>for Base</i>	Gewicht [g] <i>Weight [g]</i>	Teil-Nr. <i>Part #</i>
	41	50	6.5	098AG050
	49	60	12.0	098AG060
	49	*60	12.0	098AG060B
mit zentraler Durchgangsbohrung Ø 15 mm <i>With central Ø 15 mm bore</i>	49	60	6.5	098AG060S01
	68	80	23.0	098AG080
	68	*80	23.0	098AG080B
	87	*100	37.0	098AG100B
	107	*120	60.0	098AG120B

Bodenelemente *Floor Elements*

Stellfüße *Leveling Feet*

Feste Stellfüße *Pivot Feet*



ANTI-SLIP-PLATTE

ANTI-SLIP PLATE

Ausführung	für feste Quadrat-Stellfüße	Model	For square pivot feet
Beschreibung	verhindert das Verrutschen von Stellfüßen auf glatten Industrieböden und kann Vibrationen dämpfen	Description	Prevents movement of leveling feet on slippery surfaces and absorbs some vibration
Material	thermoplastisches Elastomer, ≈70 Shore A	Material	Thermoplastic elastomer, ≈70 Shore A
Eigenschaften	beständig gegen Öl und Wasser (bis 60 °C)	Specification	Water and oil resistant (up to 60 °C)
Liefereinheit	10 Stück	Pack Quantity	10 pieces
Extras	🌀 elektrostatisch entladend auf Anfrage	Specials	🌀 electrostatically discharging on request

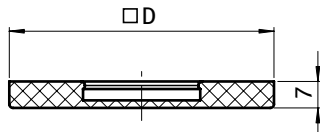

Anti-Slip-Platte <i>Anti-slip Plate</i>	D [mm]	für Teller <i>for Base</i>	Gewicht [g] <i>Weight [g]</i>	Teil-Nr. <i>Part #</i>
	50	60	24.0	098AVG060
	70	80	34.0	098AVG080
	89	100	44.0	098AVG100

1

Bodenelemente *Floor Elements*

Stellfüße *Leveling Feet*

Feste Stellfüße *Pivot Feet*



ANTI-SLIP-PLATTE

ANTI-SLIP PLATE

<p>Ausführung für Schwerlastfüße</p> <p>Beschreibung verhindert das Verrutschen von Stellfüßen auf glatten Industrieböden und kann Vibrationen dämpfen</p> <p>Material thermoplastisches Elastomer, ≈70 Shore A</p> <p>Eigenschaften beständig gegen Öl und Wasser (bis 60 °C)</p> <p>Liefereinheit 10 Stück</p> <p>Extras elektrostatisch entladend auf Anfrage</p>	<p>Model For heavy-duty feet</p> <p>Description Prevents movement of leveling feet on slippery surfaces and absorbs some vibration</p> <p>Material Thermoplastic elastomer, ≈70 Shore A</p> <p>Specification Water and oil resistant (up to 60 °C)</p> <p>Pack Quantity 10 pieces</p> <p>Specials electrostatically discharging on request</p>
---	---

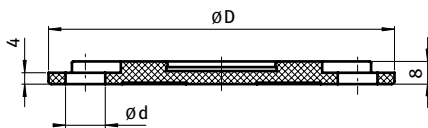

Anti-Slip-Platte <i>Anti-slip Plate</i>	D [mm]	für Teller <i>for Base</i>	Gewicht [g] <i>Weight [g]</i>	Teil-Nr. <i>Part #</i>
	122	125	88.0	098AG125B
	174	175	222.0	098AG175B



FESTER STELLFUß – GLOCKE

PIVOT FOOT – BELL

Ausführung	Stahl, verzinkt	Model	Steel, zinc plated
Beschreibung	fester, nivellierbarer Stellfuß zum Ausgleich von Bodenunebenheiten, elektrostatisch entladend, mit Mutter DIN 439 (ISO 4035) Form B; Lieferung montiert	Description	A leveling foot for slightly uneven floors, electrostatically discharging, with nut DIN 439 (ISO 4035) form B; factory assembled
Material	Teller: Stahl, verzinkt Gewindestange: Stahl, verzinkt Mutter: Stahl, verzinkt	Material	Base: Steel, zinc plated Threaded rod: Steel, zinc plated Nut: Steel, zinc plated
Liefereinheit	10 Stück	Pack Quantity	10 pieces
Hinweis	passende Anti-Slip Platte siehe Seite 64	Tip	Compatible anti-slip plate see page 64

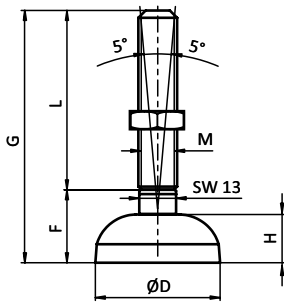

Teller Base	D [mm]	F [mm]	H [mm]	L [mm]	M × G [mm]	Tragkraft [kg] Max. Load [kg]	Gewicht [g] Weight [g]	Profil Profile	Teil-Nr. Part #
45	44	25.7	17.0	59.3	M12 × 85	1000	151.0	B	9AB045M12085MN
45	44	25.7	17.0	134.3	M12 × 160	1000	190.0	B	9AB045M12160MN
45	44	27.0	17.0	118.0	M16 × 145	1000	273.0	B	9AB045M16145MN
60	58	28.5	20.0	59.5	M12 × 88	1000	186.0	B	9AB060M12085MN
90	90	29.5	20.0	55.5	M16 × 85	2000	423.0	B	9AB090M16085MN
90	90	29.5	20.0	115.5	M16 × 145	2000	494.0	B	9AB090M16145MN
90	90	29.5	20.0	170.5	M16 × 200	2000	567.0	B	9AB090M16200MN



ANTI-SLIP-PLATTE

ANTI-SLIP PLATE

<p>Ausführung für feste Stellfüße – Glocke</p> <p>Beschreibung verhindert das Verrutschen von Stellfüßen auf glatten Industrieböden und kann Vibrationen dämpfen</p> <p>Material Polyurethan, ≈70 - 80 Shore A</p> <p>Farbe natur opak, schwarz</p> <p>Eigenschaften beständig gegen Öl und Wasser (bis 60 °C)</p> <p>Liefereinheit 10 Stück</p> <p>Extras weitere Farben auf Anfrage</p>	<p>Model For pivot feet – bell</p> <p>Description Prevents movement of leveling feet on slippery surfaces and absorbs some vibration</p> <p>Material Polyurethane, ≈70 - 80 Shore A</p> <p>Color Natural opaque, black</p> <p>Specification Water and oil resistant (up to 60 °C)</p> <p>Pack Quantity 10 pieces</p> <p>Specials Other colors on request</p>
--	---

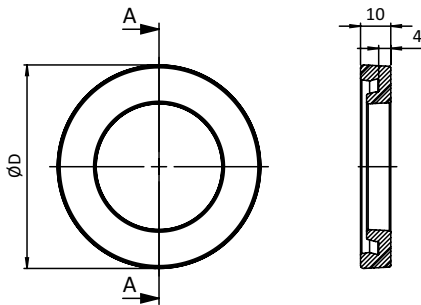

Anti-Slip-Platte <i>Anti-slip Plate</i>	D [mm]	für Teller <i>for Base</i>	Gewicht [g] <i>Weight [g]</i>	Teil-Nr. <i>Part #</i>
natur opak <i>Natural opaque</i>	52.0	45	13.0	098ABG045
	67.3	60	20.0	098ABG060
	97.3	90	29.0	098ABG090
⚡ elektrostatisch entladend, schwarz	52.0	45	13.0	098ABG045S01
⚡ <i>electrostatically discharging, black</i>	67.3	60	20.5	098ABG060S01
	97.3	90	30.0	098ABG090S01



TELLER FÜR ECO-STELLFÜßE

BASE FOR ECO FEET

Ausführung	Kunststoff PA	Model	Plastic PA
Beschreibung	preiswerter, nivellierbarer Stellfuß zum Ausgleich von Bodenunebenheiten	Description	Economical leveling foot for stable positioning on slightly uneven floors
Material	Kunststoff PA, glaskugelverstärkt	Material	Plastic PA, glass ball reinforced
Farbe	schwarz	Color	Black
Liefereinheit	100 Stück	Pack Quantity	100 pieces
Extras	☁ elektrostatisch entladend, weitere Größen, weitere Farben, geklebte Anti-Slip-Platte auf Anfrage	Specials	☁ electrostatically discharging, other sizes, other colors, glued anti-slip plate on request
Hinweis	passende Gewindestange siehe Seite 68, passende Mutter siehe Seite 80 f., passende Anti-Slip-Platte siehe Seite 70; (ECO-Stellfüße werden immer montiert geliefert)	Tip	Compatible threaded rod see page 68, Compatible nut see page 80 et sq., Compatible anti-slip-plate see page 70; (ECO feet are provided factory assembled)

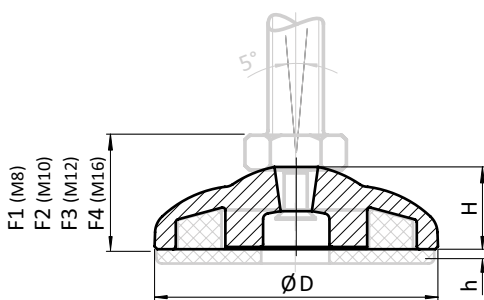

Teller Base	Teller für ECO-Stellfüße Base for ECO Feet	D [mm]	F1 [mm]	F2 [mm]	F3 [mm]	F4 [mm]	H [mm]	Tragkraft [kg] Max. Load [kg]	Gewicht [g] Weight [g]	Teil-Nr. Part #
30	ohne Anti-Slip-Platte Without anti-slip plate	29	16.0	16.5	17.5	20.0	11.5	1500	5.0	098E030K
40	ohne Anti-Slip-Platte Without anti-slip plate	39	16.5	17.0	18.0	20.5	12.0	1500	8.0	098E040K
50	ohne Anti-Slip-Platte Without anti-slip plate	50	19.8	20.3	21.3	23.8	15.3	1500	16.0	098E050K
30	mit Anti-Slip-Platte With anti-slip plate	29	16.0	16.5	17.5	20.0	11.5	1500	9.0	098E030KG
40	mit Anti-Slip-Platte With anti-slip plate	39	16.5	17.0	18.0	20.5	12.0	1500	14.0	098E040KG
50	mit Anti-Slip-Platte With anti-slip plate	50	19.8	20.3	21.3	23.8	15.3	1500	26.0	098E050KG

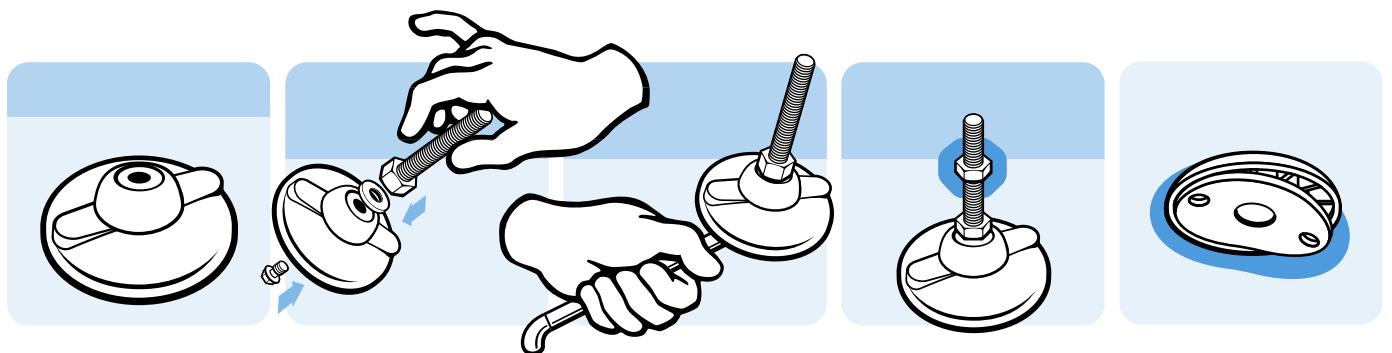

Bodenelemente *Floor Elements*

Stellfüße *Leveling Feet*

ECO-Stellfüße *ECO Feet*



TELLER FÜR ECO-STELLFÜßE

BASE FOR ECO FEET

Ausführung	Zinkdruckguss	Model	Zinc die-cast
Beschreibung	preiswerter, nivellierbarer Stellfuß zum Ausgleich von Bodenunebenheiten	Description	Economical leveling foot for strong positioning on slightly uneven floors
Material	Zinkdruckguss	Material	Zinc die-cast
Liefereinheit	100 Stück	Pack Quantity	100 pieces
Extras	weitere Oberflächen, weitere Größen, weitere Farben, geklebte Anti-Slip-Platte auf Anfrage	Specials	Other surfaces, other sizes, other colors, glued anti-slip plate on request
Hinweis	passende Gewindestange siehe Seite 68, passende Mutter siehe Seite 80 f., passende Anti-Slip-Platte siehe Seite 70; (ECO-Stellfüße werden immer montiert geliefert)	Tip	Compatible threaded rod see page 68, Compatible nut see page 80 et sq., Compatible anti-slip-plate see page 70; (ECO feet are provided factory assembled)

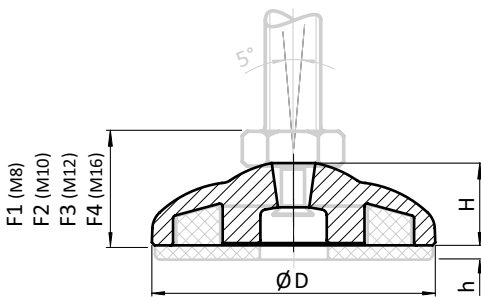

Teller Base	Teller für ECO-Stellfüße Base for ECO Feet	D [mm]	F1 [mm]	F2 [mm]	F3 [mm]	F4 [mm]	H [mm]	Oberfläche	Tragkraft [kg] Max. Load [kg]	Gewicht [g] Weight [g]	Teil-Nr. Part #
30	ohne Without anti-slip plate	29	16.0	16.5	17.5	20.0	11.5	schwarz Black	1600	20.0	098E030ZS
30	ohne Without anti-slip plate	29	16.0	16.5	17.5	20.0	11.5	verzinkt Zinc plated	1600	20.0	098E030ZV
40	ohne Without anti-slip plate	39	16.5	17.0	18.0	20.5	12.0	schwarz Black	1800	38.0	098E040ZS
40	ohne Without anti-slip plate	39	16.5	17.0	18.0	20.5	12.0	verzinkt Zinc plated	1800	38.0	098E040ZV
50	ohne Without anti-slip plate	50	19.0	19.5	20.5	23.0	14.5	schwarz Black	2000	60.0	098E050ZS
50	ohne Without anti-slip plate	50	19.0	19.5	20.5	23.0	14.5	verzinkt Zinc plated	2000	60.0	098E050ZV
30	mit With anti-slip plate	29	16.0	16.5	17.5	20.0	11.5	schwarz Black	1600	24.0	098E030ZSG
30	mit With anti-slip plate	29	16.0	16.5	17.5	20.0	11.5	verzinkt Zinc plated	1600	24.0	098E030ZVG
40	mit With anti-slip plate	39	16.5	17.0	18.0	20.5	12.0	schwarz Black	1800	44.0	098E040ZSG
40	mit With anti-slip plate	39	16.5	17.0	18.0	20.5	12.0	verzinkt Zinc plated	1800	44.0	098E040ZVG
50	mit With anti-slip plate	50	19.0	19.5	20.5	23.0	14.5	schwarz Black	2000	70.0	098E050ZSG
50	mit With anti-slip plate	50	19.0	19.5	20.5	23.0	14.5	verzinkt Zinc plated	2000	70.0	098E050ZVG

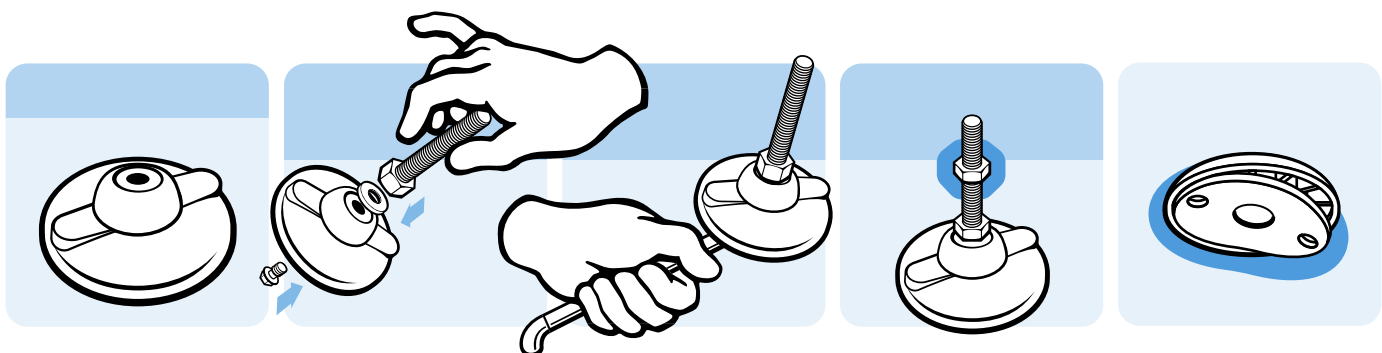

Bodenelemente Floor Elements

Stellfüße Leveling Feet

ECO-Stellfüße ECO Feet



TELLER FÜR ECO-STELLFÜßE

BASE FOR ECO FEET

Ausführung	Edelstahl	Model	Stainless steel
Beschreibung	preiswerter, nivellierbarer Stellfuß zum Ausgleich von Bodenunebenheiten	Description	Economical leveling foot for strong positioning on slightly uneven floors
Material	Edelstahl 1.4401	Material	Stainless steel SS316
Liefereinheit	100 Stück	Pack Quantity	100 pieces
Extras	weitere Größen, geklebte Anti-Slip-Platte auf Anfrage	Specials	Other sizes, glued anti-slip plate on request
Hinweis	passende Gewindestange siehe Seite 68, passende Mutter siehe Seite 80 f., passende Anti-Slip-Platte siehe Seite 70; (ECO-Stellfüße werden immer montiert geliefert)	Tip	Compatible threaded rod see page 68, Compatible nut see page 80 et sq., Compatible anti-slip-plate see page 70; (ECO feet are provided factory assembled)

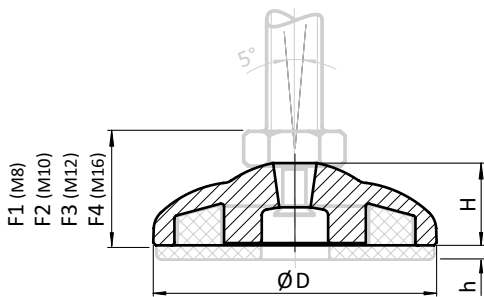

Teller Base	Teller für ECO-Stellfüße Base for ECO Feet	D [mm]	F1 [mm]	F2 [mm]	F3 [mm]	F4 [mm]	H [mm]	Tragkraft [kg] Max. Load [kg]	Gewicht [g] Weight [g]	Teil-Nr. Part #
30	ohne Anti-Slip-Platte Without anti-slip plate	29	16.0	16.5	17.5	20.0	11.5	2200	20.0	098E030E
40	ohne Anti-Slip-Platte Without anti-slip plate	39	16.5	17.0	18.0	20.5	12.0	2400	38.0	098E040E
50	ohne Anti-Slip-Platte Without anti-slip plate	50	19.0	19.5	20.5	23.0	14.5	2600	60.0	098E050E
30	mit Anti-Slip-Platte With anti-slip plate	29	16.0	16.5	17.5	20.0	11.5	2200	24.0	098E030EG
40	mit Anti-Slip-Platte With anti-slip plate	39	16.5	17.0	18.0	20.5	12.0	2400	44.0	098E040EG
50	mit Anti-Slip-Platte With anti-slip plate	50	19.0	19.5	20.5	23.0	14.5	2600	70.0	098E050EG

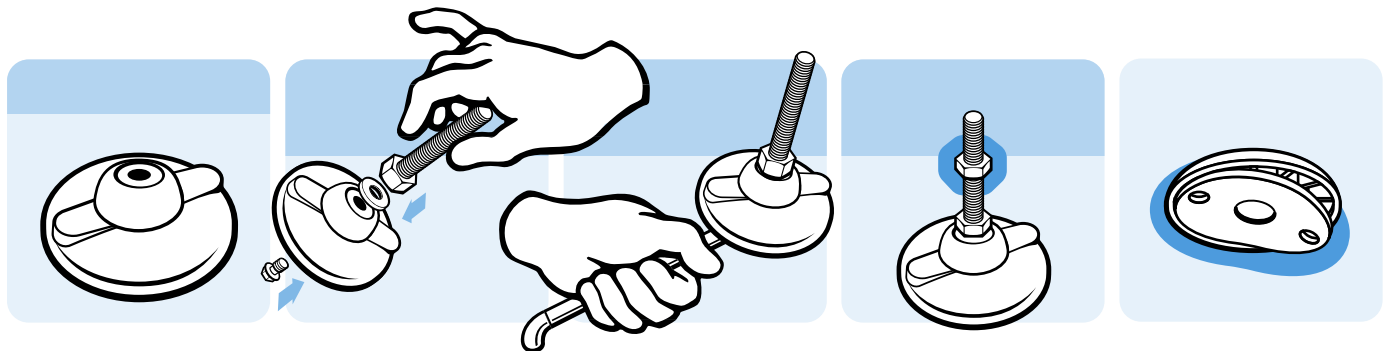



GEWINDESTANGE FÜR ECO-STELLFÜßE

THREADED ROD FOR ECO FEET

Ausführung Stahl	Model Steel
Beschreibung Gewindestange für ECO-Stellfüße	Description Threaded rod for ECO feet
Material Stahl, verzinkt	Material Steel, zinc plated
Verbindung Schwenkbereich ±5°	Screw joint Swiveling range ±5°
Liefereinheit 100 Stück	Pack Quantity 100 pieces
Extras weitere Längen und Größen auf Anfrage	Specials Other lengths and sizes on request
Hinweis Lieferung inkl. Montagestift 098XEM (ECO-Stellfüße werden immer montiert geliefert)	Tip Mounting pin 098XEM included (ECO feet are provided factory assembled)

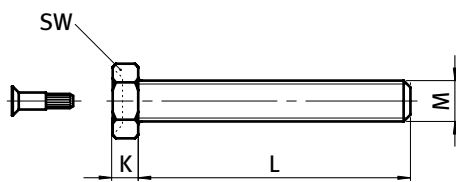

Gewindestange für ECO-Stellfüße Threaded Rod for ECO Feet	K [mm]	M × L [mm]	SW [mm]	Tragkraft [kg] Max. Load [kg]	Gewicht [g] Weight [g]	Teil-Nr. Part #
Stahl, verzinkt <i>Steel, zinc plated</i>	5.3	M8 × 25	13	350	12.0	098EM08025M
	5.3	M8 × 40	13	350	17.0	098EM08040M
	5.3	M8 × 50	13	350	20.0	098EM08050M
	5.3	M8 × 70	13	350	26.0	098EM08070M
	5.3	M8 × 80	13	350	29.0	098EM08080M
	5.3	M8 × 100	13	350	35.0	098EM08100M
	5.3	M8 × 120	13	350	41.0	098EM08120M
	6.4	M10 × 25	17	470	22.0	098EM10025M
	6.4	M10 × 40	17	470	30.0	098EM10040M
	6.4	M10 × 50	17	470	35.0	098EM10050M
	6.4	M10 × 70	17	470	44.0	098EM10070M
	6.4	M10 × 80	17	470	49.0	098EM10080M
	6.4	M10 × 100	17	470	58.0	098EM10100M
	6.4	M10 × 120	17	470	69.0	098EM10120M
	7.5	M12 × 25	19	770	34.0	098EM12025M
	7.5	M12 × 40	19	770	44.0	098EM12040M
	7.5	M12 × 50	19	770	51.0	098EM12050M
	7.5	M12 × 70	19	770	65.0	098EM12070M
	7.5	M12 × 80	19	770	72.0	098EM12080M
	7.5	M12 × 100	19	770	86.0	098EM12100M
	7.5	M12 × 120	19	770	100.0	098EM12120M
	10.0	M16 × 40	24	1450	87.0	098EM16040M
	10.0	M16 × 50	24	1450	99.0	098EM16050M
	10.0	M16 × 70	24	1450	123.0	098EM16070M
	10.0	M16 × 100	24	1450	165.0	098EM16100M
	10.0	M16 × 150	24	1450	231.0	098EM16150M



GEWINDESTANGE FÜR ECO-STELLFÜßE

THREADED ROD FOR ECO FEET

Ausführung	Edelstahl	Model	Stainless steel
Beschreibung	Gewindestange für ECO-Stellfüße	Description	Threaded rod for ECO feet
Material	Edelstahl 1.4302	Material	Stainless steel SS305
Verbindung	Schwenkbereich ±5°	Screw joint	Swiveling range ±5°
Liefereinheit	100 Stück	Pack Quantity	100 pieces
Extras	weitere Längen und Größen auf Anfrage	Specials	Other lengths and sizes on request
Hinweis	Lieferung inkl. Montagestift 098XEE (ECO-Stellfüße werden immer montiert geliefert)	Tip	Mounting pin 098XEE included (ECO feet are provided factory assembled)

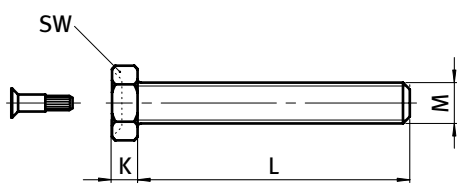

Gewindestange für ECO-Stellfüße Threaded Rod for ECO Feet	K [mm]	M × L [mm]	SW [mm]	Tragkraft [kg] Max. Load [kg]	Gewicht [g] Weight [g]	Teil-Nr. Part #
Edelstahl <i>Stainless steel</i>	5.3	M8 × 25	13	350	12.0	098EM08025E
	5.3	M8 × 40	13	350	17.0	098EM08040E
	5.3	M8 × 50	13	350	20.0	098EM08050E
	5.3	M8 × 70	13	350	26.0	098EM08070E
	5.3	M8 × 80	13	350	29.0	098EM08080E
	5.3	M8 × 100	13	350	35.0	098EM08100E
	5.3	M8 × 120	13	350	41.0	098EM08120E
	6.4	M10 × 25	17	470	22.0	098EM10025E
	6.4	M10 × 40	17	470	30.0	098EM10040E
	6.4	M10 × 50	17	470	35.0	098EM10050E
	6.4	M10 × 70	17	470	44.0	098EM10070E
	6.4	M10 × 80	17	470	49.0	098EM10080E
	6.4	M10 × 100	17	470	58.0	098EM10100E
	6.4	M10 × 120	17	470	69.0	098EM10120E
	7.5	M12 × 25	19	770	34.0	098EM12025E
	7.5	M12 × 40	19	770	44.0	098EM12040E
	7.5	M12 × 50	19	770	51.0	098EM12050E
	7.5	M12 × 70	19	770	65.0	098EM12070E
	7.5	M12 × 80	19	770	72.0	098EM12080E
	7.5	M12 × 100	19	770	86.0	098EM12100E
	7.5	M12 × 120	19	770	100.0	098EM12120E
	10.0	M16 × 40	24	1450	87.0	098EM16040E
	10.0	M16 × 50	24	1450	99.0	098EM16050E
	10.0	M16 × 70	24	1450	123.0	098EM16070E
	10.0	M16 × 100	24	1450	165.0	098EM16100E
	10.0	M16 × 150	24	1450	231.0	098EM16150E



ANTI-SLIP-PLATTE

ANTI-SLIP PLATE

<p>Ausführung für ECO Füße</p> <p>Beschreibung verhindert das Verrutschen von Stellfüßen auf glatten Industrieböden und kann Vibrationen dämpfen</p> <p>Material thermoplastisches Elastomer, ≈70 Shore A</p> <p>Eigenschaften beständig gegen Öl und Wasser (bis 60 °C)</p> <p>Liefereinheit 10 Stück</p> <p>Extras elektrostatisch entladend auf Anfrage</p>	<p>Model for ECO Feet</p> <p>Description Prevents movement of leveling feet on slippery surfaces and absorbs some vibration</p> <p>Material Thermoplastic elastomer, ≈70 Shore A</p> <p>Specification Water and oil resistant (up to 60 °C)</p> <p>Pack Quantity 10 pieces</p> <p>Specials electrostatically discharging on request</p>
---	--

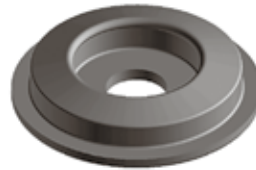
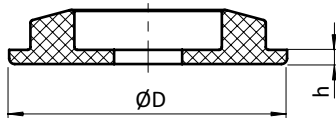

Anti-Slip-Platte <i>Anti-slip Plate</i>	D [mm]	H [mm]	für Teller <i>for Base</i>	Gewicht [g] <i>Weight [g]</i>	Teil-Nr. <i>Part #</i>
	28	2	30	4.0	098EG030
	38	2	40	6.0	098EG040
	49	2	50	10.0	098EG050



TELLER FÜR STARRE SCHWERLASTFÜßE

BASE FOR HEAVY-DUTY FIXED FEET

Ausführung	Kunststoff PA, mit Anschraubbohrungen	Model	Plastic PA, with bolt-down holes
Beschreibung	starrer, nivellierbarer Stellfuß für schwere Maschinen	Description	Leveling foot for a strong positioning of heavy machinery on the floor
Material	Kunststoff PA, glaskugelverstärkt	Material	Plastic PA, glass ball reinforced
Farbe	schwarz	Color	Black
Liefereinheit	1 Stück	Pack Quantity	1 piece
Extras	☁ elektrostatisch entladend, weitere Größen, weitere Farben, angeschraubte oder geklebte Anti-Slip-Platte auf Anfrage; als montierter Stellfuß auf Anfrage	Specials	☁ electrostatically discharging, other sizes, other colors, bolt-on or glued anti-slip plate on request; as factory assembled leveling foot on request
Hinweis	passende Gewindestange siehe Seite 72, passende Mutter siehe Seite 80 f., passende Anti-Slip Platte siehe Seite 44	Tip	Compatible threaded rod see page 72, compatible nut see page 80 et sq. compatible anti-slip plate see page 44

1

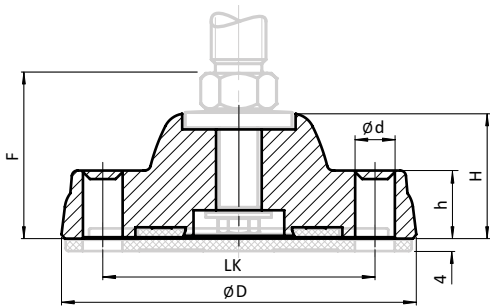

Teller Base	Teller für starre Schwerlastfüße Base for Heavy-duty Fixed Feet	D [mm]	F [mm]	H [mm]	LK [mm]	Tragkraft [kg] Max. Load [kg]	Gewicht [g] Weight [g]	Teil-Nr. Part #
125	ohne Anti-Slip-Platte Without anti-slip plate	125	57.5	44	96	1800	250.0	098K125KBZ
175	ohne Anti-Slip-Platte Without anti-slip plate	175	58.5	45	135	2500	350.0	098K175KBZ
125	mit Anti-Slip-Platte With anti-slip plate	125	57.5	44	96	1800	338.0	098K125KBZG
175	mit Anti-Slip-Platte With anti-slip plate	175	58.5	45	135	2500	572.0	098K175KBZG

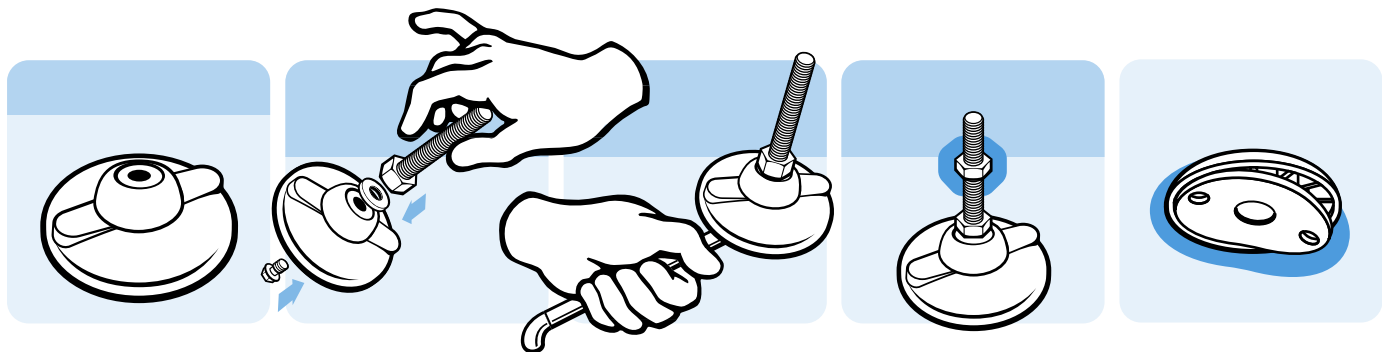

Bodenelemente *Floor Elements*

Stellfüße *Leveling Feet*

Schwerlast-Stellfüße *Heavy-duty Feet*



GEWINDESTANGE FÜR STARRE SCHWERLASTFÜßE

THREADED ROD FOR HEAVY-DUTY FIXED FEET

Ausführung	Stahl	Model	Steel
Beschreibung	Gewindestange für starre Schwerlastfüße	Description	Threaded rod for heavy-duty fixed leveling feet
Material	Stahl, verzinkt	Material	Steel, zinc plated
Verbindung	starr	Screw joint	Fixed
Liefereinheit	1 Stück	Pack Quantity	1 piece
Extras	weitere Längen und Größen auf Anfrage	Specials	Other lengths and sizes on request
Hinweis	Lieferung inkl. Montagesatz 098XKM	Tip	Assembly set 098XKM included

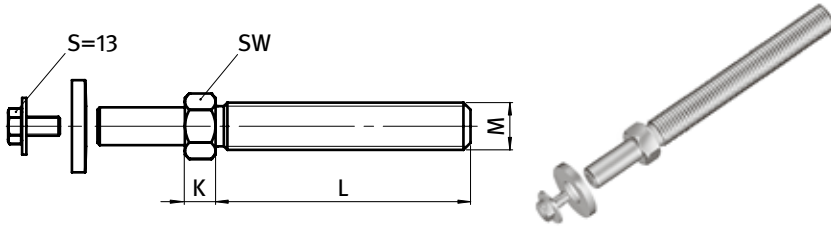

Gewindestange für starre Schwerlastfüße <i>Threaded Rod for Heavy-duty Fixed Feet</i>	K [mm]	M × L [mm]	SW [mm]	Tragkraft [kg] <i>Max. Load [kg]</i>	Gewicht [g] <i>Weight [g]</i>	Teil-Nr. <i>Part #</i>
Stahl, verzinkt <i>Steel, zinc plated</i>	12	16 × 100	24	1450	236.0	098KM16100M
	12	16 × 150	24	1450	303.0	098KM16150M
	12	16 × 200	24	1450	370.0	098KM16200M
	12	20 × 100	24	2430	314.0	098KM20100M
	12	20 × 150	24	2430	400.0	098KM20150M
	12	20 × 200	24	2430	521.0	098KM20200M
	12	24 × 100	24	3610	404.0	098KM24100M
	12	24 × 150	24	3610	555.0	098KM24150M
	12	24 × 200	24	3610	705.0	098KM24200M
	12	30 × 100	24	5770	579.0	098KM30100M
	12	30 × 150	24	5770	818.0	098KM30150M
	12	30 × 200	24	5770	1056.0	098KM30200M

Bodenelemente *Floor Elements*

Stellfüße *Leveling Feet*

Schwerlast-Stellfüße *Heavy-duty Feet*



GEWINDESTANGE FÜR STARRE SCHWERLASTFÜßE

THREADED ROD FOR HEAVY-DUTY FIXED FEET

Ausführung	Edelstahl	Model	Stainless steel
Beschreibung	Gewindestange für starre Schwerlastfüße	Description	Threaded rod for heavy-duty fixed leveling feet
Material	Edelstahl 1.4302	Material	Stainless steel SS305
Verbindung	starr	Screw joint	Fixed
Liefereinheit	1 Stück	Pack Quantity	1 piece
Extras	weitere Längen und Größen auf Anfrage	Specials	Other lengths and sizes on request
Hinweis	Lieferung inkl. Montagesatz 098XKE	Tip	Assembly set 098XKE included

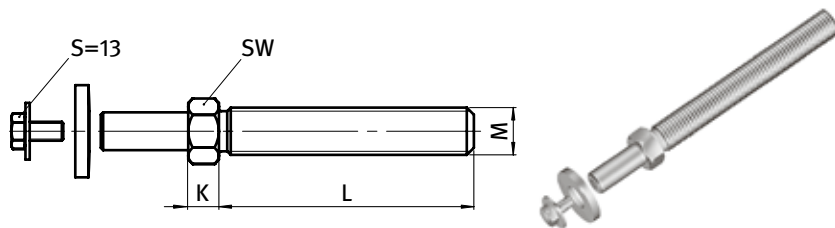

Gewindestange für starre Schwerlastfüße Threaded Rod for Heavy-duty Fixed Feet	K [mm]	M × L [mm]	SW [mm]	Tragkraft [kg] Max. Load [kg]	Gewicht [g] Weight [g]	Teil-Nr. Part #
Edelstahl <i>Stainless steel</i>	12	16 × 100	24	1450	236.0	098KM16100E
	12	16 × 150	24	1450	303.0	098KM16150E
	12	16 × 200	24	1450	370.0	098KM16200E
	12	20 × 100	24	2430	314.0	098KM20100E
	12	20 × 150	24	2430	400.0	098KM20150E
	12	20 × 200	24	2430	521.0	098KM20200E
	12	24 × 100	24	3610	404.0	098KM24100E
	12	24 × 150	24	3610	555.0	098KM24150E
	12	24 × 200	24	3610	705.0	098KM24200E
	12	30 × 100	24	5770	579.0	098KM30100E
	12	30 × 150	24	5770	818.0	098KM30150E
	12	30 × 200	24	5770	1056.0	098KM30200E

1

Bodenelemente *Floor Elements*

Stellfüße *Leveling Feet*

Schwerlast-Stellfüße *Heavy-duty Feet*



ANTI-SLIP-PLATTE

ANTI-SLIP PLATE

<p>Ausführung für Schwerlastfüße</p> <p>Beschreibung verhindert das Verrutschen von Stellfüßen auf glatten Industrieböden und kann Vibrationen dämpfen</p> <p>Material thermoplastisches Elastomer, ≈70 Shore A</p> <p>Eigenschaften beständig gegen Öl und Wasser (bis 60 °C)</p> <p>Liefereinheit 10 Stück</p> <p>Extras elektrostatisch entladend auf Anfrage</p>	<p>Model For heavy-duty feet</p> <p>Description Prevents movement of leveling feet on slippery surfaces and absorbs some vibration</p> <p>Material Thermoplastic elastomer, ≈70 Shore A</p> <p>Specification Water and oil resistant (up to 60 °C)</p> <p>Pack Quantity 10 pieces</p> <p>Specials electrostatically discharging on request</p>
---	---

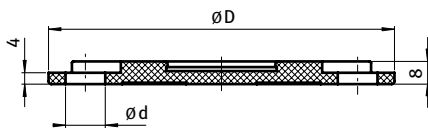

Anti-Slip-Platte <i>Anti-slip Plate</i>	D [mm]	für Teller <i>for Base</i>	Gewicht [g] <i>Weight [g]</i>	Teil-Nr. <i>Part #</i>
	122	125	88.0	098AG125B
	174	175	222.0	098AG175B

Bodenelemente *Floor Elements*

Stellfüße *Leveling Feet*

Enten-Stellfuß *Duck Feet*



TELLER FÜR ENTENFUß 16

BASE FOR DUCK FOOT 16

Ausführung	Aluminiumdruckguss	Model	Aluminum die-cast
Beschreibung	stabiler und preiswerter Stellfuß, der für Förderanlagen besonders geeignet ist	Description	A strong and cost efficient leveling foot commonly used for conveyor systems
Material	Aluminiumdruckguss	Material	Aluminum die-cast
Liefereinheit	10 Stück	Pack Quantity	10 pieces
Hinweis	passende Abdeckkappen siehe Seite 76, bitte verwenden Sie 1 Stück aus diesem Set	Tip	Compatible cover caps see page 76, please use 1 piece out of this set

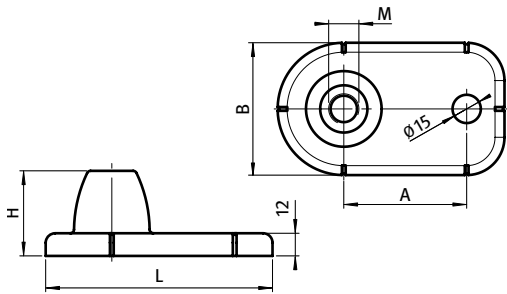

Teller für Entenfuß 16 Base for Duck Foot 16	A [mm]	L × B × H [mm]	M	Tragkraft [kg] Max. Load [kg]	Gewicht [g] Weight [g]	Teil-Nr. Part #
	65	119.5 × 70 × 45	M16	400	224.0	098F16070A

Bodenelemente *Floor Elements*

Stellfüße *Leveling Feet*

Enten-Stellfuß *Duck Feet*



TELLER FÜR ENTENFUß 20

BASE FOR DUCK FOOT 20

Ausführung	Aluminiumdruckguss	Model	Aluminum die-cast
Beschreibung	stabiler und preiswerter Stellfuß, der für Förderanlagen besonders geeignet ist	Description	A strong and cost efficient leveling foot commonly used for conveyor systems
Material	Aluminiumdruckguss	Material	Aluminum die-cast
Liefereinheit	10 Stück	Pack Quantity	10 pieces

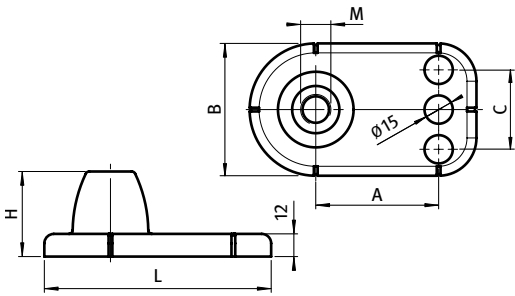

Teller für Entenfuß 20 Base for Duck Foot 20	A [mm]	C [mm]	L x B x H [mm]	M	Tragkraft [kg] Max. Load [kg]	Gewicht [g] Weight [g]	Teil-Nr. Part #
	75	55	139.5 x 90 x 50	M20	600	456.2	098F20090A
Set Abdeckkappen <i>Set cover caps</i>						4.8	098F01

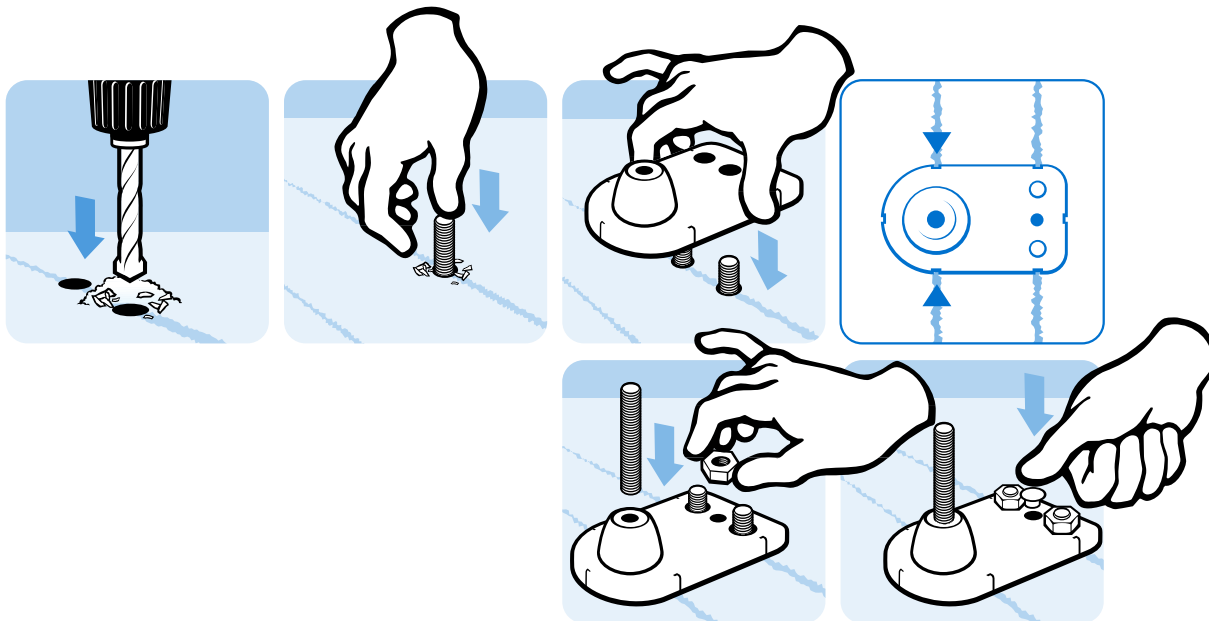

Bodenelemente *Floor Elements*

Stellfüße *Leveling Feet*

Enten-Stellfuß *Duck Feet*



MONTAGESATZ FÜR ENTEN-STELLFUß

ASSEMBLING SET FOR DUCK FOOT

Ausführung	Stahl, verzinkt / Edelstahl	Model	Steel, zinc plated / stainless steel
Beschreibung	Montagesatz, bestehend aus 2 Muttern DIN 934 und 2 Scheiben DIN 125	Description	Assembling set, including 2 nuts DIN 934 and 2 washers DIN 125
Material	Stahl, verzinkt / Edelstahl A2, blank	Material	Steel, zinc plated / stainless steel A2, plain
Liefereinheit	10 Stück	Pack Quantity	10 pieces



1

Montagesatz <i>Assembling Set</i>	Größe <i>Size</i>	Gewicht [g] <i>Weight [g]</i>	Teil-Nr. <i>Part #</i>
Stahl, verzinkt <i>Steel, zinc plated</i>	M16	79.3	098F16M
	M20	99.1	098F20M
Edelstahl <i>Stainless steel</i>	M16	79.3	098F16E
	M20	99.1	098F20E



ENTEN-STELLFUß

DUCK FOOT

Ausführung	Aluminiumdruckguss	Model	Aluminum die-cast
Beschreibung	stabiler und preiswerter Stellfuß, der für Förderanlagen besonders geeignet ist; die Gewindestange ist fixiert	Description	A strong and low cost leveling foot commonly used for conveyor systems; the threaded rod is fixed
Material	Fußsteller: Aluminiumdruckguss Gewindestange: Stahl	Material	Base: Aluminum die-cast Threaded rod: Steel
Liefereinheit	10 Stück	Pack Quantity	10 pieces
Hinweis	Passende Mutter siehe Seite 77	Tip	Compatible nut see page 77

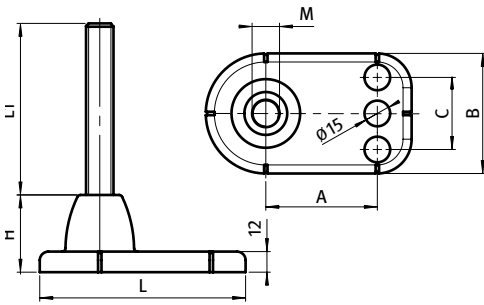

Entenfuß <i>Duck Foot</i>	Gewindestange <i>Threaded Rod</i>	A [mm]	C [mm]	L × B × H [mm]	L1 [mm]	Tragkraft [kg] <i>Max. Load [kg]</i>	Gewicht [g] <i>Weight [g]</i>	Teil-Nr. <i>Part #</i>
16	Stahl, verzinkt <i>Steel, zinc plated</i>	65	-	119.5 × 70 × 45	M16 × 100	400	452.6	9F16070A16100M
16	Stahl, verzinkt <i>Steel, zinc plated</i>	65	-	119.5 × 70 × 45	M16 × 150	400	518.1	9F16070A16150M
16	Stahl, verzinkt <i>Steel, zinc plated</i>	65	-	119.5 × 70 × 45	M16 × 200	400	581.1	9F16070A16200M
16	Stahl, verzinkt <i>Steel, zinc plated</i>	65	-	119.5 × 70 × 45	M16 × 250	400	648.1	9F16070A16250M
16	Stahl, verzinkt <i>Steel, zinc plated</i>	65	-	119.5 × 70 × 45	M16 × 300	400	713.6	9F16070A16300M
20	Stahl, verzinkt <i>Steel, zinc plated</i>	75	55	139.5 × 90 × 50	M20 × 150	600	900.0	9F20090A20150M
20	Stahl, verzinkt <i>Steel, zinc plated</i>	75	55	139.5 × 90 × 50	M20 × 200	600	1023.4	9F20090A20200M
20	Stahl, verzinkt <i>Steel, zinc plated</i>	75	55	139.5 × 90 × 50	M20 × 250	600	1146.7	9F20090A20250M
20	Stahl, verzinkt <i>Steel, zinc plated</i>	75	55	139.5 × 90 × 50	M20 × 300	600	1270.0	9F20090A20300M
20	Stahl, verzinkt <i>Steel, zinc plated</i>	75	55	139.5 × 90 × 50	M20 × 400	600	1516.6	9F20090A20400M

Set Abdeckkappen *Set cover caps*

4.8

[098F01](#)



ENTEN-STELLFUß

DUCK FOOT

Ausführung	Aluminiumdruckguss	Model	Aluminum die-cast
Beschreibung	stabiler und preiswerter Stellfuß, der für Förderanlagen besonders geeignet ist; die Gewindestange ist fixiert	Description	A strong and low cost leveling foot commonly used for conveyor systems; the threaded rod is fixed
Material	Fußsteller: Aluminiumdruckguss Gewindestange: Edelstahl 1.4301	Material	Base: Aluminum die-cast Threaded rod: Stainless steel SS304
Liefereinheit	10 Stück	Pack Quantity	10 pieces
Hinweis	Passende Mutter siehe 098F16M	Tip	Compatible nut see 098F16M

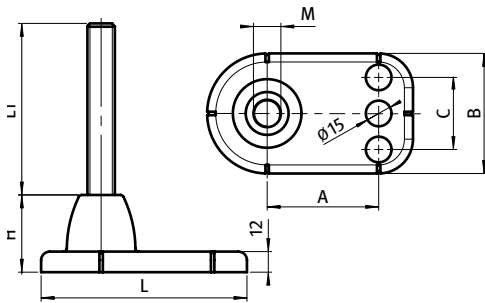

Entenfuß <i>Duck Foot</i>	Gewindestange <i>Threaded Rod</i>	A [mm]	C [mm]	L × B × H [mm]	L1 [mm]	Tragkraft [kg] <i>Max. Load [kg]</i>	Gewicht [g] <i>Weight [g]</i>	Teil-Nr. <i>Part #</i>
16	Edelstahl <i>Stainless steel</i>	65	-	119.5 × 70 × 45	M16 × 100	400	452.6	9F16070A16100E
16	Edelstahl <i>Stainless steel</i>	65	-	119.5 × 70 × 45	M16 × 150	400	518.1	9F16070A16150E
16	Edelstahl <i>Stainless steel</i>	65	-	119.5 × 70 × 45	M16 × 200	400	581.1	9F16070A16200E
16	Edelstahl <i>Stainless steel</i>	65	-	119.5 × 70 × 45	M16 × 250	400	648.1	9F16070A16250E
16	Edelstahl <i>Stainless steel</i>	65	-	119.5 × 70 × 45	M16 × 300	400	713.6	9F16070A16300E
20	Edelstahl <i>Stainless steel</i>	75	55	139.5 × 90 × 50	M20 × 150	600	900.0	9F20090A20150E
20	Edelstahl <i>Stainless steel</i>	75	55	139.5 × 90 × 50	M20 × 200	600	1023.4	9F20090A20200E
20	Edelstahl <i>Stainless steel</i>	75	55	139.5 × 90 × 50	M20 × 250	600	1146.7	9F20090A20250E
20	Edelstahl <i>Stainless steel</i>	75	55	139.5 × 90 × 50	M20 × 300	600	1270.0	9F20090A20300E
20	Edelstahl <i>Stainless steel</i>	75	55	139.5 × 90 × 50	M20 × 400	600	1516.6	9F20090A20400E
Set Abdeckkappen <i>Set cover caps</i>							4.8	098F01



MUTTER DIN 439 FÜR GEWINDESTANGE

NUT DIN 439 FOR THREADED ROD

Ausführung	Stahl / Edelstahl	Model	Steel / stainless steel
Beschreibung	flache Kontermuttern DIN 439 (ISO 4035) Form B für Gewindestangen	Description	Flat jam nuts DIN 439 (ISO 4035) form B for threaded rods
Material	Stahl, verzinkt / Edelstahl A2, blank	Material	Steel, zinc plated / stainless steel A2, plain
Liefereinheit	10 / 100 Stück	Pack Quantity	10 / 100 pieces

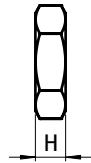
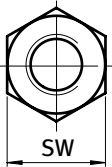

Mutter DIN 439 für Gewindestange <i>Nut DIN 439 for Threaded Rod</i>	H [mm]	SW [mm]	Gewinde Thread	Liefereinheit [Stück] Pack Quantity [Pieces]	Gewicht [g] Weight [g]	Teil-Nr. Part #
Stahl, verzinkt <i>Steel, zinc plated</i>	2.7	8	M5	100	1.0	4DIN439BM5M
	3.2	10	M6	100	1.5	4DIN439BM6M
	4.0	13	M8	100	3.0	4DIN439BM8M
	5.0	17	M10	100	6.0	4DIN439BM10M
	6.0	19	M12	100	9.0	4DIN439BM12M
	7.0	22	M14	100	14.0	4DIN439BM14M
	8.0	24	M16	100	18.0	4DIN439BM16M
	10.0	30	M20	10	33.0	4DIN439BM20M
	12.0	36	M24	10	60.0	4DIN439BM24M
	15.0	46	M30	10	100.0	4DIN439BM30M
Edelstahl <i>Stainless steel</i>	2.7	8	M5	100	1.0	4DIN439BM5E
	3.2	10	M6	100	1.5	4DIN439BM6E
	4.0	13	M8	100	3.0	4DIN439BM8E
	5.0	17	M10	100	6.0	4DIN439BM10E
	6.0	19	M12	100	9.0	4DIN439BM12E
	7.0	22	M14	100	14.0	4DIN439BM14E
	8.0	24	M16	100	18.0	4DIN439BM16E
	10.0	30	M20	10	33.0	4DIN439BM20E
	12.0	36	M24	10	60.0	4DIN439BM24E
	15.0	46	M30	10	100.0	4DIN439BM30E

MUTTER DIN 934 FÜR GEWINDESTANGE

NUT DIN 934 FOR THREADED ROD

Ausführung	Stahl / Edelstahl	Model	Steel / stainless steel
Beschreibung	Kontermutter DIN 934 (ISO 4032) für Gewindestangen	Description	Jam nuts DIN 934 (ISO 4032) for threaded rods
Material	Stahl, verzinkt / Edelstahl A2, blank	Material	Steel, zinc plated / stainless steel A2, plain
Liefereinheit	10 Stück	Pack Quantity	10 pieces

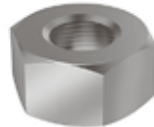
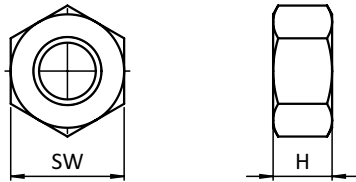

Mutter DIN 934 für Gewindestange <i>Nut DIN 934 for Threaded Rod</i>	H [mm]	SW [mm]	Gewinde <i>Thread</i>	Gewicht [g] <i>Weight [g]</i>	Teil-Nr. <i>Part #</i>
Stahl, verzinkt <i>Steel, zinc plated</i>	4.7	8	M5	1.2	4DIN934M5M
	5.2	10	M6	1.8	4DIN934M6M
	6.8	13	M8	5.0	4DIN934M8M
	8.4	16	M10	10.0	4DIN934M10M
	10.8	18	M12	15.0	4DIN934M12M
	11.0	22	M14	22.8	4DIN934M14M
	14.8	24	M16	29.2	4DIN934M16M
	18.0	30	M20	53.8	4DIN934M20M
	21.5	36	M24	93.0	4DIN934M24M
	25.6	46	M30	202.0	4DIN934M30M
Edelstahl <i>Stainless Steel</i>	4.7	8	M5	1.2	4DIN934M5E
	6.8	13	M8	5.0	4DIN934M8E
	5.2	10	M6	1.8	4DIN934M6E
	8.4	16	M10	10.0	4DIN934M10E
	10.8	18	M12	15.0	4DIN934M12E
	11.0	22	M14	22.8	4DIN934M14E
	14.8	24	M16	29.2	4DIN934M16E
	18.0	30	M20	53.8	4DIN934M20E
	21.5	36	M24	93.0	4DIN934M24E
	25.6	46	M30	202.0	4DIN934M30E

HUB-SCHRAUBER

ADJUSTABLE LEVELING FOOT

Ausführung	Kunststoff PA	Model	Plastic PA
Beschreibung	kompakter, ohne Werkzeug nivellierbarer Stellfuß zur Befestigung an Alu-Profilen	Description	Leveling foot for fastening to aluminum profiles, height adjustable without tool
Material	Gehäuse: Kunststoff PA, glasfaserverstärkt Mechanik: Stahl verzinkt	Material	Housing: Plastic PA, glass fiber reinforced Mechanism: Steel, zinc plated
Farbe	schwarz	Color	Black
Liefereinheit	10 Stück	Pack Quantity	10 pieces
Extras	⚡ elektrostatisch entladend, weitere Größen, weitere Farben auf Anfrage	Specials	⚡ electrostatically discharging, other sizes, other colors on request

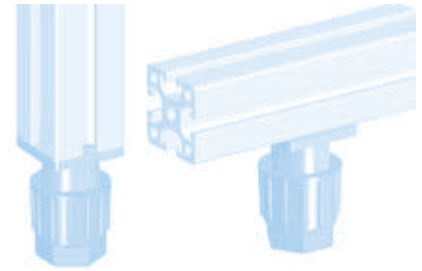
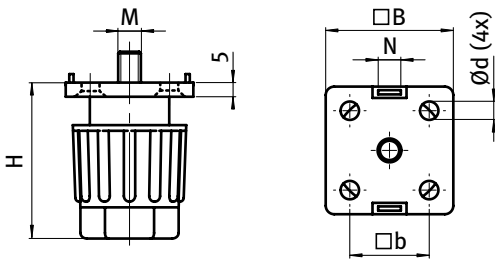

Hub-Schrauber <i>Adjustable Leveling Foot</i>	B [mm]	H [mm]	M	N [mm]	Gewicht [g] <i>Weight [g]</i>	Teil-Nr. <i>Part #</i>
	30	35-50	M6	6	38.0	098H300606
	30	35-50	M8	8	40.0	098H300808
	35	35-50	M8	8	42.0	098H350808
	35	35-50	M8	10	42.0	098H351008
	40	45-65	M8	8	78.0	098H400808
	40	45-65	M8	10	78.0	098H401008
	45	45-65	M8	8	80.0	098H450808
	45	45-65	M8	10	80.0	098H451008
	50	45-65	M8	8	83.0	098H500808
	50	45-65	M8	10	83.0	098H501008

GEWINDESTOPFEN FÜR VIERKANTROHRE

THREADED BUSH FOR SQUARE TUBES

Ausführung	Kunststoff PA, mit Messing-Gewindeeinsatz	Model	Plastic PA, with brass threaded insert
Beschreibung	zur Aufnahme von Stellfüßen an der Stirnseite von Vierkantrohren	Description	To fit leveling feet to square, non-threaded tubes
Material	Stopfen: Kunststoff PA, glasfaserverstärkt Gewindeeinsatz: Messing vernickelt	Material	Bush: Plastic PA, glass fiber reinforced Threaded insert: Nickel plated brass
Farbe	schwarz	Color	Black
Liefereinheit	10 Stück	Pack Quantity	10 pieces
Extras	⚡ elektrostatisch entladend, weitere Größen, weitere Farben auf Anfrage	Specials	⚡ electrostatically discharging, other sizes, other colors on request

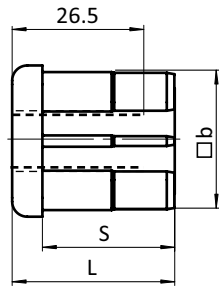

Gewindestopfen <i>Threaded bushes</i>	B [mm]	L [mm]	M	S [mm]	Vierkantrohr [mm] <i>Square Tube [mm]</i>	Tragkraft [kg] <i>Max. Load [kg]</i>	Gewicht [g] <i>Weight [g]</i>	Teil-Nr. <i>Part #</i>
30 × 30, R3	30	33	M8	27	30 × 30 × 1.5	500	69.0	098V301508
	30	33	M10	27	30 × 30 × 1.5	500	54.0	098V301510
	30	33	M12	27	30 × 30 × 1.5	500	57.0	098V301512
	30	33	M14	27	30 × 30 × 1.5	500	48.0	098V301514
	30	33	M16	27	30 × 30 × 1.5	500	52.0	098V301516
	30	33	M8	27	30 × 30 × 2.0	500	68.0	098V302008
	30	33	M10	27	30 × 30 × 2.0	500	63.0	098V302010
	30	33	M12	27	30 × 30 × 2.0	500	56.0	098V302012
	30	33	M14	27	30 × 30 × 2.0	500	47.0	098V302014
	30	33	M16	27	30 × 30 × 2.0	500	51.0	098V302016

GEWINDESTOPFEN FÜR VIERKANTROHRE

THREADED BUSH FOR SQUARE TUBES

Ausführung	Kunststoff PA, mit Messing-Gewindeeinsatz	Model	Plastic PA, with brass threaded insert
Beschreibung	zur Aufnahme von Stellfüßen an der Stirnseite von Vierkantrohren	Description	To fit leveling feet to square, non-threaded tubes
Material	Stopfen: Kunststoff PA, glasfaserverstärkt Gewindeeinsatz: Messing vernickelt	Material	Bush: Plastic PA, glass fiber reinforced Threaded insert: Nickel plated brass
Farbe	schwarz	Color	Black
Liefereinheit	10 Stück	Pack Quantity	10 pieces
Extras	⚡ elektrostatisch entladend, weitere Größen, weitere Farben auf Anfrage	Specials	⚡ electrostatically discharging, other sizes, other colors on request

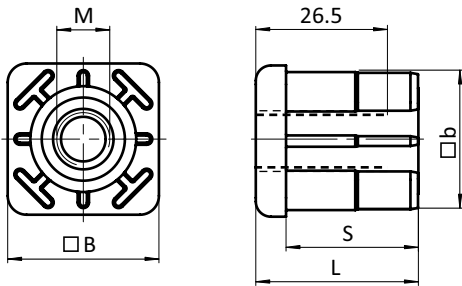

Gewindestopfen <i>Threaded bushes</i>	B [mm]	L [mm]	M	S [mm]	Vierkantrohr [mm] <i>Square Tube [mm]</i>	Tragkraft [kg] <i>Max. Load [kg]</i>	Gewicht [g] <i>Weight [g]</i>	Teil-Nr. <i>Part #</i>
40 × 40, R5	40	43	M8	35	40 × 40 × 1.5	800	96.0	098V401508
	40	43	M10	35	40 × 40 × 1.5	800	91.0	098V401510
	40	43	M12	35	40 × 40 × 1.5	800	84.0	098V401512
	40	43	M14	35	40 × 40 × 1.5	800	75.0	098V401514
	40	43	M16	35	40 × 40 × 1.5	800	79.0	098V401516
	40	43	M20	35	40 × 40 × 1.5	800	75.0	098V401520
	40	43	M8	35	40 × 40 × 2.0	1000	93.0	098V402008
	40	43	M10	35	40 × 40 × 2.0	1000	88.0	098V402010
	40	43	M12	35	40 × 40 × 2.0	1000	81.0	098V402012
	40	43	M14	35	40 × 40 × 2.0	1000	72.0	098V402014
	40	43	M16	35	40 × 40 × 2.0	1000	76.0	098V402016
	40	43	M20	35	40 × 40 × 2.0	1000	74.0	098V402020
	40	43	M8	35	40 × 40 × 2.5	1000	93.0	098V402508
	40	43	M10	35	40 × 40 × 2.5	1000	88.0	098V402510
	40	43	M12	35	40 × 40 × 2.5	1000	81.0	098V402512
	40	43	M14	35	40 × 40 × 2.5	1000	72.0	098V402514
	40	43	M16	35	40 × 40 × 2.5	1000	76.0	098V402516
	40	43	M20	35	40 × 40 × 2.5	1000	74.0	098V402520
	40	43	M8	35	40 × 40 × 3.0	1000	95.0	098V403008
	40	43	M10	35	40 × 40 × 3.0	1000	90.0	098V403010
	40	43	M12	35	40 × 40 × 3.0	1000	83.0	098V403012
	40	43	M14	35	40 × 40 × 3.0	1000	74.0	098V403014
	40	43	M16	35	40 × 40 × 3.0	1000	78.0	098V403016
	40	43	M20	35	40 × 40 × 3.0	1000	76.0	098V403020
	40	43	M8	35	40 × 40 × 4.0	1000	91.0	098V404008
	40	43	M10	35	40 × 40 × 4.0	1000	86.0	098V404010
	40	43	M12	35	40 × 40 × 4.0	1000	79.0	098V404012
	40	43	M14	35	40 × 40 × 4.0	1000	70.0	098V404014
	40	43	M16	35	40 × 40 × 4.0	1000	74.0	098V404016
	40	43	M20	35	40 × 40 × 4.0	1000	72.0	098V404020

GEWINDESTOPFEN FÜR VIERKANTROHRE

THREADED BUSH FOR SQUARE TUBES

Ausführung	Kunststoff PA, mit Messing-Gewindeeinsatz	Model	Plastic PA, with brass threaded insert
Beschreibung	zur Aufnahme von Stellfüßen an der Stirnseite von Vierkantrohren	Description	To fit leveling feet to square, non-threaded tubes
Material	Stopfen: Kunststoff PA, glasfaserverstärkt Gewindeeinsatz: Messing vernickelt	Material	Bush: Plastic PA, glass fiber reinforced Threaded insert: Nickel plated brass
Farbe	schwarz	Color	Black
Liefereinheit	10 Stück	Pack Quantity	10 pieces
Extras	⚡ elektrostatisch entladend, weitere Größen, weitere Farben auf Anfrage	Specials	⚡ electrostatically discharging, other sizes, other colors on request

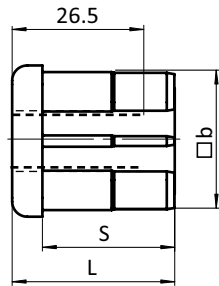
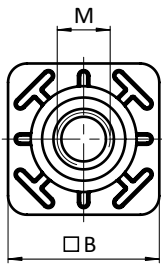

Gewindestopfen <i>Threaded bushes</i>	B [mm]	L [mm]	M	S [mm]	Vierkantrohr [mm] <i>Square Tube [mm]</i>	Tragkraft [kg] <i>Max. Load [kg]</i>	Gewicht [g] <i>Weight [g]</i>	Teil-Nr. <i>Part #</i>
50 x 50, R5	50	55	M10	44	50 x 50 x 1.5	800	120.0	098V501510
	50	55	M12	44	50 x 50 x 1.5	800	113.0	098V501512
	50	55	M14	44	50 x 50 x 1.5	800	104.0	098V501514
	50	55	M16	44	50 x 50 x 1.5	800	108.0	098V501516
	50	55	M20	44	50 x 50 x 1.5	800	102.0	098V501520
	50	55	M8	44	50 x 50 x 2.0	1200	113.0	098V502008
	50	55	M10	44	50 x 50 x 2.0	1200	108.0	098V502010
	50	55	M12	44	50 x 50 x 2.0	1200	101.0	098V502012
	50	55	M14	44	50 x 50 x 2.0	1200	92.0	098V502014
	50	55	M16	44	50 x 50 x 2.0	1200	96.0	098V502016
	50	55	M20	44	50 x 50 x 2.0	1200	101.0	098V502020
	50	55	M10	44	50 x 50 x 2.5	1200	120.0	098V502510
	50	55	M12	44	50 x 50 x 2.5	1200	113.0	098V502512
	50	55	M14	44	50 x 50 x 2.5	1200	113.0	098V502514
	50	55	M16	44	50 x 50 x 2.5	1200	108.0	098V502516
	50	55	M20	44	50 x 50 x 2.5	1200	100.0	098V502520
	50	55	M10	44	50 x 50 x 3.0	1200	116.0	098V503010
	50	55	M12	44	50 x 50 x 3.0	1200	109.0	098V503012
	50	55	M14	44	50 x 50 x 3.0	1200	100.0	098V503014
	50	55	M16	44	50 x 50 x 3.0	1200	104.0	098V503016
	50	55	M20	44	50 x 50 x 3.0	1200	99.0	098V503020
	50	55	M10	44	50 x 50 x 4.0	1200	116.0	098V504010
	50	55	M12	44	50 x 50 x 4.0	1200	109.0	098V504012
	50	55	M14	44	50 x 50 x 4.0	1200	100.0	098V504014
	50	55	M16	44	50 x 50 x 4.0	1200	104.0	098V504016
	50	55	M20	44	50 x 50 x 4.0	1200	98.0	098V504020

GEWINDESTOPFEN FÜR VIERKANTROHRE

THREADED BUSH FOR SQUARE TUBES

Ausführung	Kunststoff PA, mit Messing-Gewindeeinsatz	Model	Plastic PA, with brass threaded insert
Beschreibung	zur Aufnahme von Stellfüßen an der Stirnseite von Vierkantrohren	Description	To fit leveling feet to square, non-threaded tubes
Material	Stopfen: Kunststoff PA, glasfaserverstärkt Gewindeeinsatz: Messing vernickelt	Material	Bush: Plastic PA, glass fiber reinforced Threaded insert: Nickel plated brass
Farbe	schwarz	Color	Black
Liefereinheit	10 Stück	Pack Quantity	10 pieces
Extras	⚡ elektrostatisch entladend, weitere Größen, weitere Farben auf Anfrage	Specials	⚡ electrostatically discharging, other sizes, other colors on request

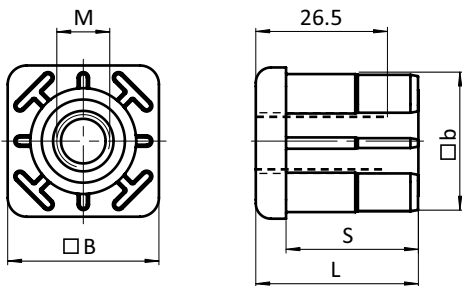

Gewindestopfen Threaded bushes	B [mm]	L [mm]	M	S [mm]	Vierkantrohr [mm] Square Tube [mm]	Tragkraft [kg] Max. Load [kg]	Gewicht [g] Weight [g]	Teil-Nr. Part #
60 × 60, R7	60	55	M10	45	60 × 60 × 2.0	1200	148.0	098V602010
	60	55	M12	45	60 × 60 × 2.0	1200	141.0	098V602012
	60	55	M14	45	60 × 60 × 2.0	1200	132.0	098V602014
	60	55	M16	45	60 × 60 × 2.0	1200	136.0	098V602016
	60	55	M20	45	60 × 60 × 2.0	1200	121.0	098V602020
	60	55	M10	45	60 × 60 × 3.0	1200	147.0	098V603010
	60	55	M12	45	60 × 60 × 3.0	1200	140.0	098V603012
	60	55	M14	45	60 × 60 × 3.0	1200	131.0	098V603014
	60	55	M16	45	60 × 60 × 3.0	1200	135.0	098V603016
	60	55	M20	45	60 × 60 × 3.0	1200	119.0	098V603020
	60	55	M10	45	60 × 60 × 4.0	1200	147.0	098V604010
	60	55	M12	45	60 × 60 × 4.0	1200	140.0	098V604012
	60	55	M14	45	60 × 60 × 4.0	1200	131.0	098V604014
	60	55	M16	45	60 × 60 × 4.0	1200	135.0	098V604016
	60	55	M20	45	60 × 60 × 4.0	1200	116.0	098V604020

GEWINDESTOPFEN FÜR RECHTECKIGE VIERKANTROHRE *THREADED BUSH FOR RECTANGULAR TUBES*

Ausführung	Kunststoff PA, mit Messing-Gewindeeinsatz	Model	Plastic PA, with brass threaded insert
Beschreibung	zur Aufnahme von Stellfüßen an der Stirnseite von rechteckigen Vierkantrohren	Description	To fit leveling feet to rectangular tubes
Material	Stopfen: Kunststoff PA, glasfaserverstärkt Gewindeeinsatz: Messing vernickelt	Material	Bush: Plastic PA, glass fiber reinforced Threaded insert: Nickel plated brass
Farbe	schwarz	Color	Black
Liefereinheit	10 Stück	Pack Quantity	10 pieces
Extras	⚡ elektrostatisch entladend, weitere Größen, weitere Farben auf Anfrage	Specials	⚡ electrostatically discharging, other sizes, other colors on request

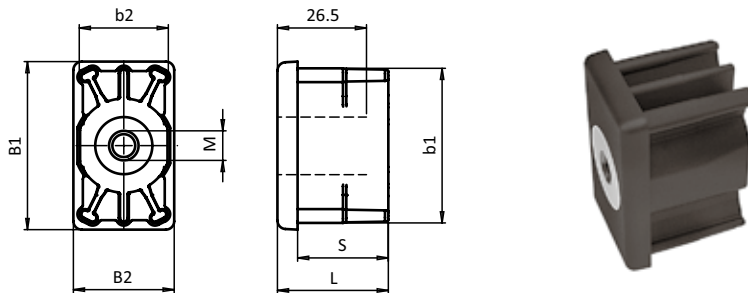

Gewindestopfen <i>Threaded bushes</i>	B1 [mm]	B2 [mm]	L [mm]	M	S [mm]	Vierkantrohr [mm] <i>Square Tube [mm]</i>	Tragkraft [kg] <i>Max. Load [kg]</i>	Gewicht [g] <i>Weight [g]</i>	Teil-Nr. <i>Part #</i>
50 × 30, R2.5	50	30	33	M8	27	50 × 30 × 2.0	500	79.0	098VE50302008
	50	30	33	M10	27	50 × 30 × 2.0	500	74.0	098VE50302010
	50	30	33	M12	27	50 × 30 × 2.0	500	67.0	098VE50302012
	50	30	33	M14	27	50 × 30 × 2.0	500	58.0	098VE50302014
	50	30	33	M16	27	50 × 30 × 2.0	500	52.0	098VE50302016

Bodenelemente *Floor Elements*
 Gewindestopfen *Threaded Bushes*
 für Rundrohre *For Round Tubes*



GEWINDESTOPFEN FÜR RUNDROHR Ø 30

THREADED BUSH FOR ROUND TUBES Ø 30

Ausführung	Kunststoff PA, mit Messing-Gewindeeinsatz	Model	Plastic PA, with brass threaded insert
Beschreibung	zur Aufnahme von Stellfüßen an der Stirnseite von Rundrohren	Description	To fit leveling feet to round, non-threaded tubes
Material	Stopfen: Kunststoff PA, glasfaserverstärkt Gewindeeinsatz: Messing vernickelt	Material	Bush: Plastic PA, glass fiber reinforced Threaded insert: Nickel plated brass
Farbe	schwarz	Color	Black
Liefereinheit	10 Stück	Pack Quantity	10 pieces
Extras	⚡ elektrostatisch entladend, weitere Größen, weitere Farben auf Anfrage	Specials	⚡ electrostatically discharging, other sizes, other colors on request

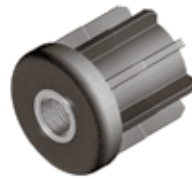
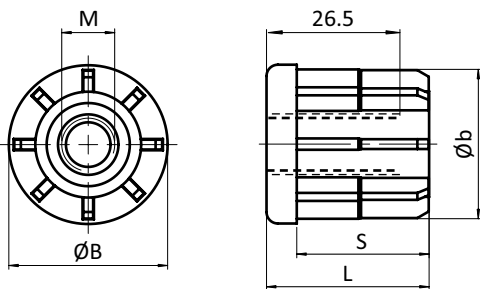

Gewindestopfen <i>Threaded bushes</i>	B [mm]	L [mm]	M	S [mm]	Rundrohr [mm] <i>Round Tube [mm]</i>	Tragkraft [kg] <i>Max. Load [kg]</i>	Gewicht [g] <i>Weight [g]</i>	Teil-Nr. <i>Part #</i>
Ø 30	30.0	33	M8	27	Ø 30 × 1.0	500	64.0	098VR301008
	30.0	33	M10	27	Ø 30 × 1.0	500	59.0	098VR301010
	30.0	33	M12	27	Ø 30 × 1.0	500	52.0	098VR301012
	30.0	33	M14	27	Ø 30 × 1.0	500	43.0	098VR301014
	30.0	33	M16	27	Ø 30 × 1.0	500	47.0	098VR301016
	30.0	33	M8	27	Ø 30 × 1.5	500	58.0	098VR301508
	30.0	33	M10	27	Ø 30 × 1.5	500	52.0	098VR301510
	30.0	33	M12	27	Ø 30 × 1.5	500	50.0	098VR301512
	30.0	33	M14	27	Ø 30 × 1.5	500	39.0	098VR301514
	30.0	33	M16	27	Ø 30 × 1.5	500	34.0	098VR301516
	30.0	33	M8	27	Ø 30 × 2.0	500	57.5	098VR302008
	30.0	33	M10	27	Ø 30 × 2.0	500	52.5	098VR302010
	30.0	33	M12	27	Ø 30 × 2.0	500	50.5	098VR302012
	30.0	33	M14	27	Ø 30 × 2.0	500	42.5	098VR302014
	30.0	33	M16	27	Ø 30 × 2.0	500	47.5	098VR302016
	30.0	33	M8	27	Ø 30 × 2.5	500	57.0	098VR302508
	30.0	33	M10	27	Ø 30 × 2.5	500	52.0	098VR302510
	30.0	33	M12	27	Ø 30 × 2.5	500	50.0	098VR302512
	30.0	33	M14	27	Ø 30 × 2.5	500	42.0	098VR302514
	30.0	33	M16	27	Ø 30 × 2.5	500	47.0	098VR302516

GEWINDESTOPFEN FÜR RUNDROHR Ø 38

THREADED BUSH FOR ROUND TUBES Ø 38

Ausführung	Kunststoff PA, mit Messing-Gewindeeinsatz	Model	Plastic PA, with brass threaded insert
Beschreibung	zur Aufnahme von Stellfüßen an der Stirnseite von Rundrohren	Description	To fit leveling feet to round, non-threaded tubes
Material	Stopfen: Kunststoff PA, glasfaserverstärkt Gewindeeinsatz: Messing vernickelt	Material	Bush: Plastic PA, glass fiber reinforced Threaded insert: Nickel plated brass
Farbe	schwarz	Color	Black
Liefereinheit	10 Stück	Pack Quantity	10 pieces
Extras	⚡ elektrostatisch entladend, weitere Größen, weitere Farben auf Anfrage	Specials	⚡ electrostatically discharging, other sizes, other colors on request

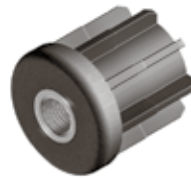
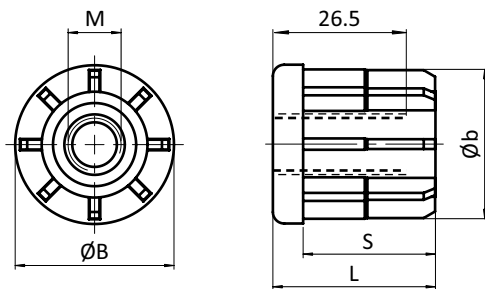

Gewindestopfen <i>Threaded bushes</i>	B [mm]	L [mm]	M	S [mm]	Rundrohr [mm] <i>Round Tube [mm]</i>	Tragkraft [kg] <i>Max. Load [kg]</i>	Gewicht [g] <i>Weight [g]</i>	Teil-Nr. <i>Part #</i>
Ø 38	38.0	43	M10	35	Ø 38 × 1.5	600	76.0	098VR381510
	38.0	43	M12	35	Ø 38 × 1.5	600	69.0	098VR381512
	38.0	43	M14	35	Ø 38 × 1.5	600	60.0	098VR381514
	38.0	43	M16	35	Ø 38 × 1.5	600	64.0	098VR381516
	38.0	43	M10	35	Ø 38 × 2.0	600	76.0	098VR382010
	38.0	43	M12	35	Ø 38 × 2.0	600	69.0	098VR382012
	38.0	43	M14	35	Ø 38 × 2.0	600	60.0	098VR382014
	38.0	43	M16	35	Ø 38 × 2.0	600	64.0	098VR382016
	38.0	43	M10	35	Ø 38 × 2.5	600	76.0	098VR382510
	38.0	43	M12	35	Ø 38 × 2.5	600	69.0	098VR382512
	38.0	43	M14	35	Ø 38 × 2.5	600	60.0	098VR382514
	38.0	43	M16	35	Ø 38 × 2.5	600	64.0	098VR382516

Bodenelemente *Floor Elements*
 Gewindestopfen *Threaded Bushes*
 für Rundrohre *For Round Tubes*



GEWINDESTOPFEN FÜR RUNDROHR Ø 42,4

THREADED BUSH FOR ROUND TUBES Ø 42.4

Ausführung	Kunststoff PA, mit Messing-Gewindeeinsatz	Model	Plastic PA, with brass threaded insert
Beschreibung	zur Aufnahme von Stellfüßen an der Stirnseite von Rundrohren	Description	To fit leveling feet to round, non-threaded tubes
Material	Stopfen: Kunststoff PA, glasfaserverstärkt Gewindeeinsatz: Messing vernickelt	Material	Bush: Plastic PA, glass fiber reinforced Threaded insert: Nickel plated brass
Farbe	schwarz	Color	Black
Liefereinheit	10 Stück	Pack Quantity	10 pieces
Extras	⚡ elektrostatisch entladend, weitere Größen, weitere Farben auf Anfrage	Specials	⚡ electrostatically discharging, other sizes, other colors on request

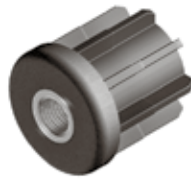
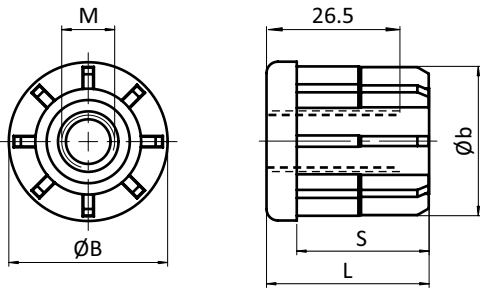

Gewindestopfen Threaded bushes	B [mm]	L [mm]	M	S [mm]	Rundrohr [mm] Round Tube [mm]	Tragkraft [kg] Max. Load [kg]	Gewicht [g] Weight [g]	Teil-Nr. Part #
Ø 42.4	42.4	43	M10	35	Ø 42.4 × 1.5	800	81.0	098VR421510
	42.4	43	M12	35	Ø 42.4 × 1.5	800	74.0	098VR421512
	42.4	43	M14	35	Ø 42.4 × 1.5	800	65.0	098VR421514
	42.4	43	M16	35	Ø 42.4 × 1.5	800	69.0	098VR421516
	42.4	43	M20	35	Ø 42.4 × 1.5	800	65.0	098VR421520
	42.4	43	M10	35	Ø 42.4 × 2.0	800	81.0	098VR422010
	42.4	43	M12	35	Ø 42.4 × 2.0	800	74.0	098VR422012
	42.4	43	M14	35	Ø 42.4 × 2.0	800	65.0	098VR422014
	42.4	43	M16	35	Ø 42.4 × 2.0	800	69.0	098VR422016
	42.4	43	M20	35	Ø 42.4 × 2.0	800	64.0	098VR422020
	42.4	43	M10	35	Ø 42.4 × 2.5	800	81.0	098VR422510
	42.4	43	M12	35	Ø 42.4 × 2.5	800	74.0	098VR422512
	42.4	43	M14	35	Ø 42.4 × 2.5	800	65.0	098VR422514
	42.4	43	M16	35	Ø 42.4 × 2.5	800	69.0	098VR422516
	42.4	43	M20	35	Ø 42.4 × 2.5	800	64.0	098VR422520

Bodenelemente *Floor Elements*
 Gewindestopfen *Threaded Bushes*
 für Rundrohre *For Round Tubes*



GEWINDESTOPFEN FÜR RUNDROHR Ø 48,3

THREADED BUSH FOR ROUND TUBES Ø 48.3

Ausführung	Kunststoff PA, mit Messing-Gewindeinsatz	Model	Plastic PA, with brass threaded insert
Beschreibung	zur Aufnahme von Stellfüßen an der Stirnseite von Rundrohren	Description	To fit leveling feet to round, non-threaded tubes
Material	Stopfen: Kunststoff PA, glasfaserverstärkt Gewindeinsatz: Messing vernickelt	Material	Bush: Plastic PA, glass fiber reinforced Threaded insert: Nickel plated brass
Farbe	schwarz	Color	Black
Liefereinheit	10 Stück	Pack Quantity	10 pieces
Extras	⚡ elektrostatisch entladend, weitere Größen, weitere Farben auf Anfrage	Specials	⚡ electrostatically discharging, other sizes, other colors on request

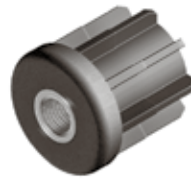
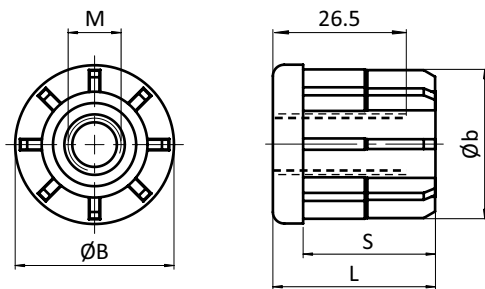

Gewindestopfen <i>Threaded bushes</i>	B [mm]	L [mm]	M	S [mm]	Rundrohr [mm] <i>Round Tube [mm]</i>	Tragkraft [kg] <i>Max. Load [kg]</i>	Gewicht [g] <i>Weight [g]</i>	Teil-Nr. <i>Part #</i>
Ø 48.3	48.3	55	M12	44	Ø 48.3 × 1.5	1000	88.0	098VR481512
	48.3	55	M14	44	Ø 48.3 × 1.5	1000	79.0	098VR481514
	48.3	55	M16	44	Ø 48.3 × 1.5	1000	83.0	098VR481516
	48.3	55	M20	44	Ø 48.3 × 1.5	1000	80.0	098VR481520
	48.3	55	M12	44	Ø 48.3 × 2.0	1000	88.0	098VR482012
	48.3	55	M14	44	Ø 48.3 × 2.0	1000	79.0	098VR482014
	48.3	55	M16	44	Ø 48.3 × 2.0	1000	83.0	098VR482016
	48.3	55	M20	44	Ø 48.3 × 2.0	1000	78.0	098VR482020
	48.3	55	M12	44	Ø 48.3 × 2.5	1000	88.0	098VR482512
	48.3	55	M14	44	Ø 48.3 × 2.5	1000	79.0	098VR482514
	48.3	55	M16	44	Ø 48.3 × 2.5	1000	70.0	098VR482516
	48.3	55	M20	44	Ø 48.3 × 2.5	1000	77.0	098VR482520

Bodenelemente *Floor Elements*
 Gewindestopfen *Threaded Bushes*
 für Rundrohre *For Round Tubes*



GEWINDESTOPFEN FÜR RUNDROHR Ø 50,9

THREADED BUSH FOR ROUND TUBES Ø 50.9

Ausführung	Kunststoff PA, mit Messing-Gewindeeinsatz	Model	Plastic PA, with brass threaded insert
Beschreibung	zur Aufnahme von Stellfüßen an der Stirnseite von Rundrohren	Description	To fit leveling feet to round, non-threaded tubes
Material	Stopfen: Kunststoff PA, glasfaserverstärkt Gewindeeinsatz: Messing vernickelt	Material	Bush: Plastic PA, glass fiber reinforced Threaded insert: Nickel plated brass
Farbe	schwarz	Color	Black
Liefereinheit	10 Stück	Pack Quantity	10 pieces
Extras	⚡ elektrostatisch entladend, weitere Größen, weitere Farben auf Anfrage	Specials	⚡ electrostatically discharging, other sizes, other colors on request

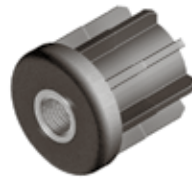
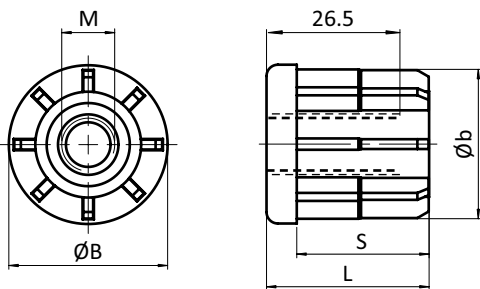

Gewindestopfen <i>Threaded bushes</i>	B [mm]	L [mm]	M	S [mm]	Rundrohr [mm] <i>Round Tube [mm]</i>	Tragkraft [kg] <i>Max. Load [kg]</i>	Gewicht [g] <i>Weight [g]</i>	Teil-Nr. <i>Part #</i>
Ø 50.9	50.9	55	M12	44	Ø 50.9 × 1.5	1000	102.0	098VR511512
	50.9	55	M14	44	Ø 50.9 × 1.5	1000	83.0	098VR511514
	50.9	55	M16	44	Ø 50.9 × 1.5	1000	87.0	098VR511516
	50.9	55	M20	44	Ø 50.9 × 1.5	1000	89.5	098VR511520
	50.9	55	M12	44	Ø 50.9 × 2.0	1000	92.0	098VR512012
	50.9	55	M14	44	Ø 50.9 × 2.0	1000	83.0	098VR512014
	50.9	55	M16	44	Ø 50.9 × 2.0	1000	87.0	098VR512016
	50.9	55	M20	44	Ø 50.9 × 2.0	1000	83.0	098VR512020
	50.9	55	M12	44	Ø 50.9 × 2.5	1000	92.0	098VR512512
	50.9	55	M14	44	Ø 50.9 × 2.5	1000	83.0	098VR512514
	50.9	55	M16	44	Ø 50.9 × 2.5	1000	87.0	098VR512516
	50.9	55	M20	44	Ø 50.9 × 2.5	1000	83.0	098VR512520

GEWINDESTOPFEN FÜR RUNDROHR Ø 60,3

THREADED BUSH FOR ROUND TUBES Ø 60.3

Ausführung	Kunststoff PA, mit Messing-Gewindeeinsatz	Model	Plastic PA, with brass threaded insert
Beschreibung	zur Aufnahme von Stellfüßen an der Stirnseite von Rundrohren	Description	To fit leveling feet to round, non-threaded tubes
Material	Stopfen: Kunststoff PA, glasfaserverstärkt Gewindeeinsatz: Messing vernickelt	Material	Bush: Plastic PA, glass fiber reinforced Threaded insert: Nickel plated brass
Farbe	schwarz	Color	Black
Liefereinheit	10 Stück	Pack Quantity	10 pieces
Extras	⚡ elektrostatisch entladend, weitere Größen, weitere Farben auf Anfrage	Specials	⚡ electrostatically discharging, other sizes, other colors on request

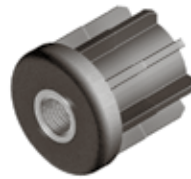
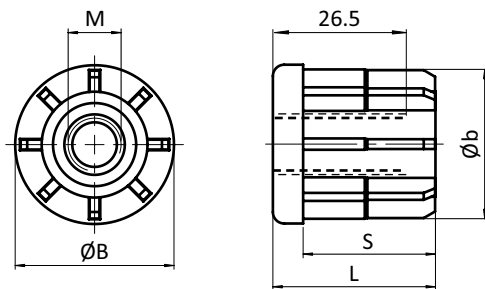

Gewindestopfen <i>Threaded bushes</i>	B [mm]	L [mm]	M	S [mm]	Rundrohr [mm] <i>Round Tube [mm]</i>	Tragkraft [kg] <i>Max. Load [kg]</i>	Gewicht [g] <i>Weight [g]</i>	Teil-Nr. <i>Part #</i>
Ø 60.3	60.3	55	M12	44	Ø 60.3 × 2.0	1000	113.0	098VR602012
	60.3	55	M14	44	Ø 60.3 × 2.0	1000	106.0	098VR602014
	60.3	55	M16	44	Ø 60.3 × 2.0	1000	108.0	098VR602016
	60.3	55	M20	44	Ø 60.3 × 2.0	1000	110.0	098VR602020
	60.3	55	M12	44	Ø 60.3 × 2.5	1000	113.0	098VR602512
	60.3	55	M14	44	Ø 60.3 × 2.5	1000	106.0	098VR602514
	60.3	55	M16	44	Ø 60.3 × 2.5	1000	98.0	098VR602516
	60.3	55	M20	44	Ø 60.3 × 2.5	1000	109.0	098VR602520
	60.3	55	M12	44	Ø 60.3 × 3.0	1000	112.0	098VR603012
	60.3	55	M14	44	Ø 60.3 × 3.0	1000	105.0	098VR603014
	60.3	55	M16	44	Ø 60.3 × 3.0	1000	98.0	098VR603016
	60.3	55	M20	44	Ø 60.3 × 3.0	1000	108.0	098VR603020
	60.3	55	M12	44	Ø 60.3 × 4.0	1000	110.0	098VR604012
	60.3	55	M14	44	Ø 60.3 × 4.0	1000	105.0	098VR604014
	60.3	55	M16	44	Ø 60.3 × 4.0	1000	102.0	098VR604016
	60.3	55	M20	44	Ø 60.3 × 4.0	1000	105.0	098VR604020

GEWINDEHÜLSE

THREADED SLEEVE

Ausführung Stahl	Model Steel
Beschreibung zur Aufnahme von Stellfüßen im rechten Winkel zum Profil; zur Montage muss ein Loch mit \varnothing 17 mm in das Profil gebohrt werden	Description To fit levelling feet to profiles at right angles; a hole must be drilled with \varnothing 17 mm through the profile to allow application
Material Stahl	Material Steel
Liefereinheit 50 Stück	Pack Quantity 50 pieces
Extras weitere Größen, weitere Oberflächen auf Anfrage	Specials Other sizes, other surfaces on request

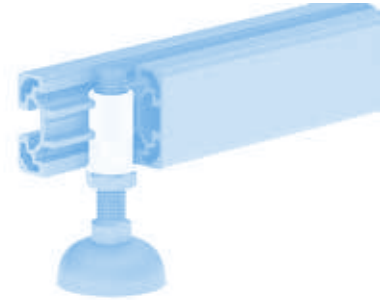
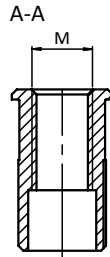
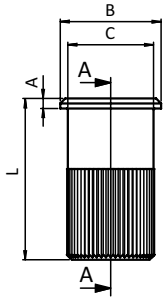

Gewindehülse Threaded Sleeve	A [mm]	L [mm]	\varnothing B [mm]	\varnothing C [mm]	Größe Size	Gewicht [g] Weight [g]	Teil-Nr. Part #
	2.0	32.0	20.0	17.0	M12	30.0	340ME201



TRANSPORT- UND FUßPLATTE 40 × 80

TRANSPORT AND BASE PLATE 40 × 80

Ausführung	Aluminiumdruckguss	Model	Aluminum die-cast
Beschreibung	zur Aufnahme von Stellfüßen, Rollen, Haken oder ähnlichen Bauteilen; stirnseitig mit den Profilen verschraubbar	Description	To mount leveling feet, rollers, hooks or similar components; screw joint to the face of the profile
Material	Aluminiumdruckguss	Material	Aluminum die-cast
Liefereinheit	10 Stück	Pack Quantity	10 pieces
Extras	weitere Oberflächen, weitere Farben auf Anfrage	Specials	Other surfaces, other colors on request

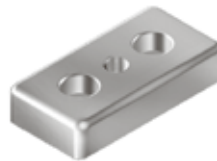
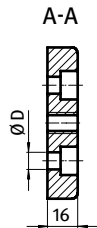
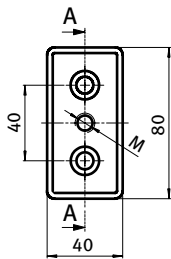

Transport- und Fußplatte 40 × 80 <i>Transport and Base Plate 40 × 80</i>	M	ØD [mm]	Gewicht [g] <i>Weight [g]</i>	Teil-Nr. <i>Part #</i>
	M8	9 (M8)	90.4	093TA40800808R
	M10	9 (M8)	89.5	093TA40801008R
	M12	9 (M8)	88.3	093TA40801208R
	M14	9 (M8)	87.0	093TA40801408R
	M16	9 (M8)	85.2	093TA40801608R
	M20	9 (M8)	81.3	093TA40802008R

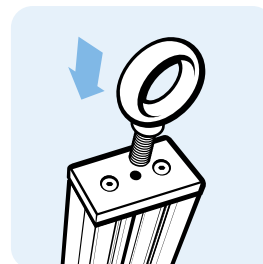
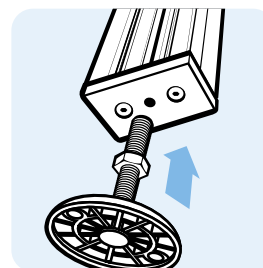
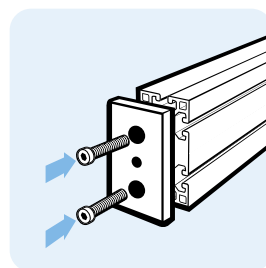



TRANSPORT- UND FUßPLATTE 80 × 80

TRANSPORT AND BASE PLATE 80 × 80

Ausführung	Aluminiumdruckguss	Model	Aluminum die-cast
Beschreibung	zur Aufnahme von Stellfüßen, Rollen, Haken oder ähnlichen Bauteilen; stirnseitig mit den Profilen verschraubbar	Description	To mount leveling feet, rollers, hooks or similar components; screw joint to the face of the profile
Material	Aluminiumdruckguss	Material	Aluminum die-cast
Liefereinheit	10 Stück	Pack Quantity	10 pieces
Extras	weitere Oberflächen, weitere Farben auf Anfrage	Specials	Other surfaces, other colors on request

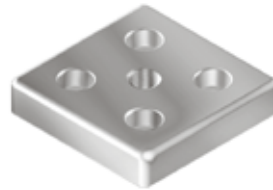
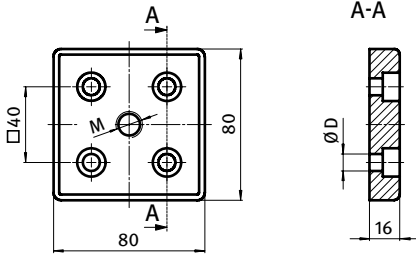

Transport- und Fußplatte 80 × 80
Transport and Base Plate 80 × 80

M	ØD [mm]	Gewicht [g] <i>Weight [g]</i>	Teil-Nr. <i>Part #</i>
M8	9 (M8)	166.5	093TA80800808R
M10	9 (M8)	165.5	093TA80801008R
M12	9 (M8)	164.5	093TA80801208R
M14	9 (M8)	163.2	093TA80801408R
M16	9 (M8)	160.0	093TA80801608R
M20	9 (M8)	158.0	093TA80802008R

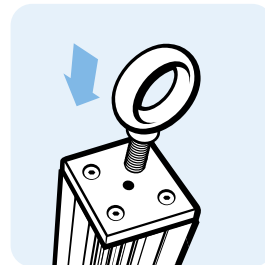
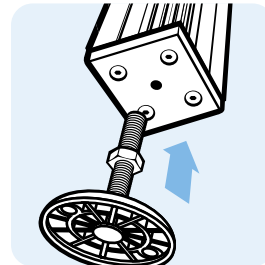
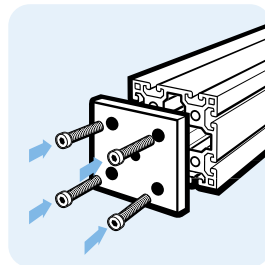

TRANSPORT- UND FUßPLATTE 20 × 40

TRANSPORT AND BASE PLATE 20 × 40

Ausführung	Zinkdruckguss	Model	Die-cast zinc
Beschreibung	zur Befestigung von Stellfüßen, Rollen, Haken oder ähnlichen Bauteilen; stirnseitig mit den Profilen verschraubbar	Description	To mount leveling feet, rollers, hooks or similar components; screw joint to the face of the profile
Material	Zinkdruckguss	Material	Die-cast zinc
Oberfläche	blank / schwarz pulverbeschichtet	Surface	Plain / black powder coated
Liefereinheit	10 Stück	Pack Quantity	10 pieces
Extras	weitere Oberflächen, weitere Farben auf Anfrage	Specials	Other surfaces, other colors on request

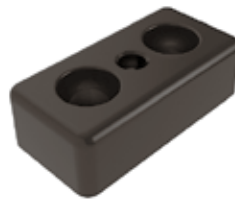
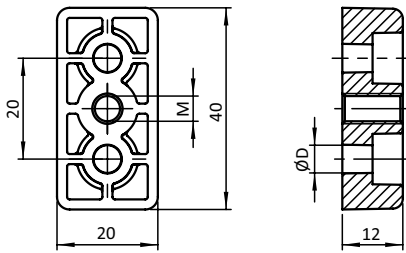

Transport- und Fußplatte 20 × 40 <i>Transport and Base Plate 20 × 40</i>	M	ØD [mm]	Gewicht [g] <i>Weight [g]</i>	Teil-Nr. <i>Part #</i>
pulverbeschichtet <i>Powder coated</i>	M6	5.5 (M5)	36.0	093T20400605S
blank <i>Plain</i>	M6	5.5 (M5)	35.0	093T20400605R

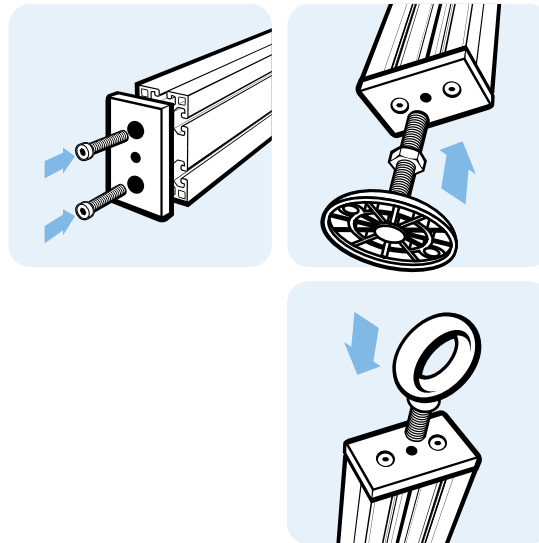



TRANSPORT- UND FUßPLATTE 40 × 40

TRANSPORT AND BASE PLATE 40 × 40

Ausführung	Zinkdruckguss	Model	Zinc die-cast
Beschreibung	zur Aufnahme von Stellfüßen, Rollen, Haken oder ähnlichen Bauteilen, stirnseitig mit den Profilen verschraubbar	Description	To mount leveling feet, casters, hooks or similar components; screw joint to the face of the profile
Material	Zinkdruckguss	Material	Zinc die-cast
Liefereinheit	10 Stück	Pack Quantity	10 pieces
Extras	weitere Oberflächen, weitere Farben auf Anfrage	Specials	Other surfaces, other colors on request

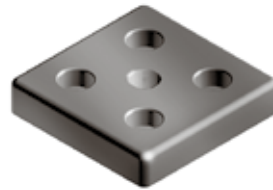
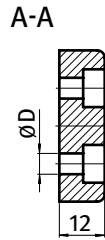
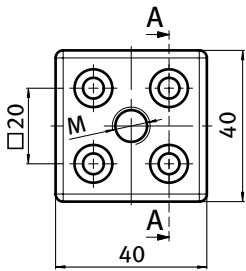

Transport- und Fußplatte 40 × 40
Transport and Base Plate 40 × 40

	M	ØD [mm]	Gewicht [g] <i>Weight [g]</i>	Teil-Nr <i>Part#</i>
pulverbeschichtet <i>Powder coated</i>	M8	5.5 (M5)	81.0	093T40400805S
	M10	5.5 (M5)	79.0	093T40401005S
	M12	5.5 (M5)	77.0	093T40401205S
blank <i>Plain</i>	M8	5.5 (M5)	81.0	093T40400805R
	M10	5.5 (M5)	79.0	093T40401005R
	M12	5.5 (M5)	77.0	093T40401205R

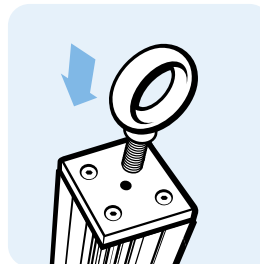
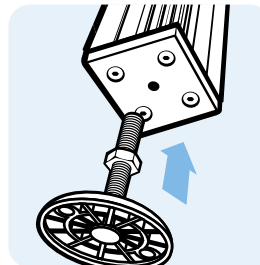
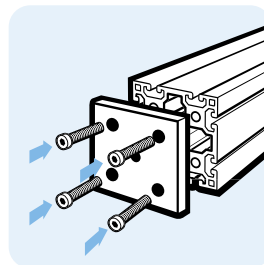

TRANSPORT- UND FUßPLATTE 30 × 60

TRANSPORT AND BASE PLATE 30 × 60

Ausführung	Zinkdruckguss	Model	Zinc die-cast
Beschreibung	zur Aufnahme von Stellfüßen, Rollen, Haken oder ähnlichen Bauteilen; stirnseitig mit den Profilen verschraubbar	Description	To mount leveling feet, rollers, hooks or similar components; screw joint to the face of the profile
Material	Zinkdruckguss	Material	Zinc die-cast
Liefereinheit	10 Stück	Pack Quantity	10 pieces
Extras	weitere Oberflächen, weitere Farben auf Anfrage	Specials	Other surfaces, other colors on request

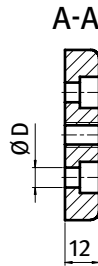
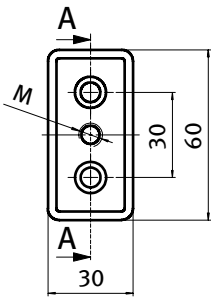

Transport- und Fußplatte 30 × 60 <i>Transport and Base Plate 30 × 60</i>	M	ØD [mm]	Gewicht [g] <i>Weight [g]</i>	Teil-Nr <i>Part#</i>
pulverbeschichtet <i>Powder coated</i>	M8	7 (M6)	101.0	093T30600806S
	M8	9 (M8)	100.0	093T30600808S
	M10	7 (M6)	99.0	093T30601006S
	M10	9 (M8)	98.0	093T30601008S
	M12	7 (M6)	97.0	093T30601206S
	M12	9 (M8)	96.0	093T30601208S
	M14	7 (M6)	95.0	093T30601406S
	M14	9 (M8)	94.0	093T30601408S
	M16	7 (M6)	93.0	093T30601606S
	M16	9 (M8)	92.0	093T30601608S
blank <i>Plain</i>	M8	7 (M6)	101.0	093T30600806R
	M8	9 (M8)	100.0	093T30600808R
	M10	7 (M6)	99.0	093T30601006R
	M10	9 (M8)	98.0	093T30601008R
	M12	7 (M6)	97.0	093T30601206R
	M12	9 (M8)	96.0	093T30601208R
	M14	7 (M6)	95.0	093T30601406R
	M14	9 (M8)	94.0	093T30601408R
	M16	7 (M6)	93.0	093T30601606R
	M16	9 (M8)	92.0	093T30601608R



TRANSPORT- UND FUßPLATTE 60 × 60

TRANSPORT AND BASE PLATE 60 × 60

Ausführung	Zinkdruckguss	Model	Zinc die-cast
Beschreibung	zur Aufnahme von Stellfüßen, Rollen, Haken oder ähnlichen Bauteilen; stirnseitig mit den Profilen verschraubbar	Description	To mount leveling feet, rollers, hooks or similar components; screw joint to the face of the profile
Material	Zinkdruckguss	Material	Zinc die-cast
Liefereinheit	10 Stück	Pack Quantity	10 pieces
Extras	weitere Oberflächen, weitere Farben auf Anfrage	Specials	Other surfaces, other colors on request

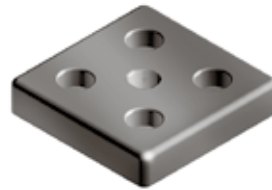
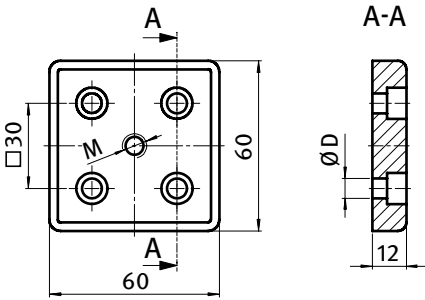

Transport- und Fußplatte 60 × 60 <i>Transport and Base Plate 60 × 60</i>	M	ØD [mm]	Gewicht [g] <i>Weight [g]</i>	Teil-Nr <i>Part#</i>
pulverbeschichtet <i>Powder coated</i>	M8	7 (M6)	183.0	093T60600806S
	M8	9 (M8)	181.0	093T60600808S
	M10	7 (M6)	181.0	093T60601006S
	M10	9 (M8)	179.0	093T60601008S
	M12	7 (M6)	179.0	093T60601206S
	M12	9 (M8)	177.0	093T60601208S
	M14	7 (M6)	177.0	093T60601406S
	M14	9 (M8)	175.0	093T60601408S
	M16	7 (M6)	175.0	093T60601606S
	M16	9 (M8)	173.0	093T60601608S
blank <i>Plain</i>	M8	7 (M6)	183.0	093T60600806R
	M8	9 (M8)	181.0	093T60600808R
	M10	7 (M6)	181.0	093T60601006R
	M10	9 (M8)	179.0	093T60601008R
	M12	7 (M6)	179.0	093T60601206R
	M12	9 (M8)	177.0	093T60601208R
	M14	7 (M6)	177.0	093T60601406R
	M14	9 (M8)	175.0	093T60601408R
	M16	7 (M6)	175.0	093T60601606R
	M16	9 (M8)	173.0	093T60601608R



TRANSPORT- UND FUßPLATTE 40 × 80

TRANSPORT AND BASE PLATE 40 × 80

Ausführung	Zinkdruckguss	Model	Zinc die-cast
Beschreibung	zur Aufnahme von Stellfüßen, Rollen, Haken oder ähnlichen Bauteilen; stirnseitig mit den Profilen verschraubbar	Description	To mount leveling feet, rollers, hooks or similar components; screw joint to the face of the profile
Material	Zinkdruckguss	Material	Zinc die-cast
Liefereinheit	10 Stück	Pack Quantity	10 pieces
Extras	weitere Oberflächen, weitere Farben auf Anfrage	Specials	Other surfaces, other colors on request

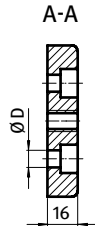
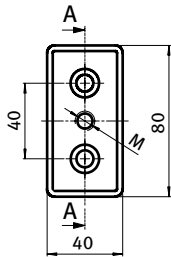

Transport- und Fußplatte 40 × 80 <i>Transport and Base Plate 40 × 80</i>	M	ØD [mm]	Gewicht [g] <i>Weight [g]</i>	Teil-Nr <i>Part#</i>
pulverbeschichtet <i>Powder coated</i>	M8	9 (M8)	213.0	093T40800808S
	M8	14.5 (M12)	192.0	093T40800812S
	M10	9 (M8)	211.0	093T40801008S
	M10	14.5 (M12)	190.0	093T40801012S
	M12	9 (M8)	209.0	093T40801208S
	M12	14.5 (M12)	188.0	093T40801212S
	M14	9 (M8)	203.0	093T40801408S
	M14	14.5 (M12)	182.0	093T40801412S
	M16	9 (M8)	199.0	093T40801608S
	M16	14.5 (M12)	178.0	093T40801612S
	M20	9 (M8)	195.0	093T40802008S
blank <i>Plain</i>	M8	9 (M8)	213.0	093T40800808R
	M8	14.5 (M12)	192.0	093T40800812R
	M10	9 (M8)	211.0	093T40801008R
	M10	14.5 (M12)	190.0	093T40801012R
	M12	9 (M8)	209.0	093T40801208R
	M12	14.5 (M12)	188.0	093T40801212R
	M14	9 (M8)	203.0	093T40801408R
	M14	14.5 (M12)	182.0	093T40801412R
	M16	9 (M8)	199.0	093T40801608R
	M16	14.5 (M12)	178.0	093T40801612R
	M20	9 (M8)	195.0	093T40802008R



TRANSPORT- UND FUßPLATTE 80 × 80

TRANSPORT AND BASE PLATE 80 × 80

Ausführung	Zinkdruckguss	Model	Zinc die-cast
Beschreibung	zur Aufnahme von Stellfüßen, Rollen, Haken oder ähnlichen Bauteilen; stirnseitig mit den Profilen verschraubbar	Description	To mount leveling feet, rollers, hooks or similar components; screw joint to the face of the profile
Material	Zinkdruckguss	Material	Zinc die-cast
Liefereinheit	10 Stück	Pack Quantity	10 pieces
Extras	weitere Oberflächen, weitere Farben auf Anfrage	Specials	Other surfaces, other colors on request

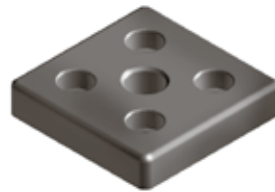
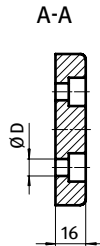
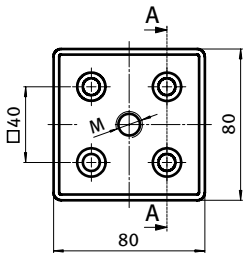

Transport- und Fußplatte 80 × 80 <i>Transport and Base Plate 80 × 80</i>	M	ØD [mm]	Gewicht [g] <i>Weight [g]</i>	Teil-Nr <i>Part#</i>
pulverbeschichtet <i>Powder coated</i>	M8	9 (M8)	483.0	093T80800808S
	M8	14.5 (M12)	384.0	093T80800812S
	M10	9 (M8)	436.0	093T80801008S
	M10	14.5 (M12)	382.0	093T80801012S
	M12	9 (M8)	433.0	093T80801208S
	M12	14.5 (M12)	380.0	093T80801212S
	M14	9 (M8)	437.0	093T80801408S
	M14	14.5 (M12)	374.0	093T80801412S
	M16	9 (M8)	425.0	093T80801608S
	M16	14.5 (M12)	367.0	093T80801612S
	M20	9 (M8)	416.0	093T80802008S
	M20	14.5 (M12)	353.0	093T80802012S
blank <i>Plain</i>	M8	9 (M8)	483.0	093T80800808R
	M8	14.5 (M12)	384.0	093T80800812R
	M10	9 (M8)	436.0	093T80801008R
	M10	14.5 (M12)	382.0	093T80801012R
	M12	9 (M8)	433.0	093T80801208R
	M12	14.5 (M12)	380.0	093T80801212R
	M14	9 (M8)	437.0	093T80801408R
	M14	14.5 (M12)	374.0	093T80801412R
	M16	9 (M8)	425.0	093T80801608R
	M16	14.5 (M12)	367.0	093T80801612R
	M20	9 (M8)	416.0	093T80802008R
	M20	14.5 (M12)	353.0	093T80802012R



TRANSPORT- UND FUßPLATTE 45 × 90

TRANSPORT AND BASE PLATE 45 × 90

Ausführung	Zinkdruckguss	Model	Zinc die-cast
Beschreibung	zur Aufnahme von Stellfüßen, Rollen, Haken oder ähnlichen Bauteilen; stirnseitig mit den Profilen verschraubbar	Description	To mount leveling feet, rollers, hooks or similar components; screw joint to the face of the profile
Material	Zinkdruckguss	Material	Zinc die-cast
Liefereinheit	10 Stück	Pack Quantity	10 pieces
Extras	weitere Oberflächen, weitere Farben auf Anfrage	Specials	Other surfaces, other colors on request

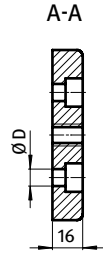
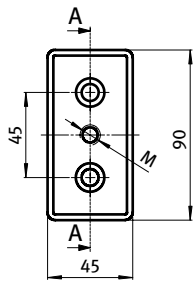

Transport- und Fußplatte 45 × 90 <i>Transport and Base Plate 45 × 90</i>	M	ØD [mm]	Gewicht [g] <i>Weight [g]</i>	Teil-Nr <i>Part#</i>
pulverbeschichtet <i>Powder coated</i>	M10	9 (M8)	280.0	093T45901008S
	M10	14.5 (M12)	257.0	093T45901012S
	M12	9 (M8)	276.0	093T45901208S
	M12	14.5 (M12)	255.0	093T45901212S
	M14	9 (M8)	270.0	093T45901408S
	M14	14.5 (M12)	253.0	093T45901412S
	M16	9 (M8)	266.0	093T45901608S
	M16	14.5 (M12)	247.0	093T45901612S
	M20	9 (M8)	256.0	093T45902008S
	M20	14.5 (M12)	243.0	093T45902012S
blank <i>Plain</i>	M10	9 (M8)	280.0	093T45901008R
	M10	14.5 (M12)	257.0	093T45901012R
	M12	9 (M8)	276.0	093T45901208R
	M12	14.5 (M12)	255.0	093T45901212R
	M14	9 (M8)	270.0	093T45901408R
	M14	14.5 (M12)	253.0	093T45901412R
	M16	9 (M8)	266.0	093T45901608R
	M16	14.5 (M12)	247.0	093T45901612R
	M20	9 (M8)	256.0	093T45902008R
	M20	14.5 (M12)	243.0	093T45902012R



TRANSPORT- UND FUßPLATTE 90 × 90

TRANSPORT AND BASE PLATE 90 × 90

Ausführung	Zinkdruckguss	Model	Zinc die-cast
Beschreibung	zur Aufnahme von Stellfüßen, Rollen, Haken oder ähnlichen Bauteilen; stirnseitig mit den Profilen verschraubbar	Description	To mount leveling feet, rollers, hooks or similar components; screw joint to the face of the profile
Material	Zinkdruckguss	Material	Zinc die-cast
Liefereinheit	10 Stück	Pack Quantity	10 pieces
Extras	weitere Oberflächen, weitere Farben auf Anfrage	Specials	Other surfaces, other colors on request

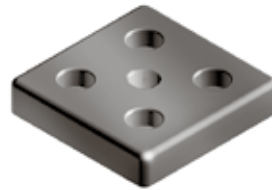
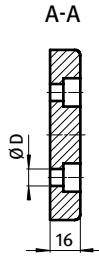
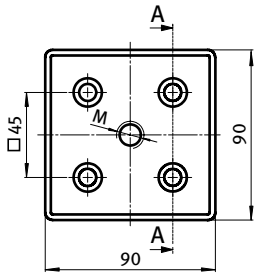

Transport- und Fußplatte 90 × 90 <i>Transport and Base Plate 90 × 90</i>	M	ØD [mm]	Gewicht [g] <i>Weight [g]</i>	Teil-Nr <i>Part#</i>
pulverbeschichtet <i>Powder coated</i>	M10	9 (M8)	522.0	093T90901008S
	M10	14.5 (M12)	482.0	093T90901012S
	M12	9 (M8)	520.0	093T90901208S
	M12	14.5 (M12)	480.0	093T90901212S
	M14	9 (M8)	519.0	093T90901408S
	M14	14.5 (M12)	475.0	093T90901412S
	M16	9 (M8)	516.0	093T90901608S
	M16	14.5 (M12)	471.0	093T90901612S
	M20	9 (M8)	510.0	093T90902008S
	M20	14.5 (M12)	463.0	093T90902012S
blank <i>Plain</i>	M10	9 (M8)	522.0	093T90901008R
	M10	14.5 (M12)	482.0	093T90901012R
	M12	9 (M8)	520.0	093T90901208R
	M12	14.5 (M12)	480.0	093T90901212R
	M14	9 (M8)	519.0	093T90901408R
	M14	14.5 (M12)	475.0	093T90901412R
	M16	9 (M8)	516.0	093T90901608R
	M16	14.5 (M12)	471.0	093T90901612R
	M20	9 (M8)	510.0	093T90902008R
	M20	14.5 (M12)	463.0	093T90902012R



TRANSPORT- UND FUßPLATTE 50 × 100

TRANSPORT AND BASE PLATE 50 × 100

Ausführung	Zinkdruckguss	Model	Zinc die-cast
Beschreibung	zur Aufnahme von Stellfüßen, Rollen, Haken oder ähnlichen Bauteilen; stirnseitig mit den Profilen verschraubbar	Description	To mount leveling feet, rollers, hooks or similar components; screw joint to the face of the profile
Material	Zinkdruckguss	Material	Zinc die-cast
Liefereinheit	10 Stück	Pack Quantity	10 pieces
Extras	weitere Oberflächen, weitere Farben auf Anfrage	Specials	Other surfaces, other colors on request

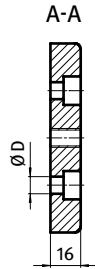
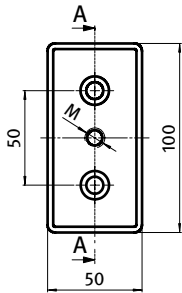

Transport- und Fußplatte 50 × 100 <i>Transport and Base Plate 50 × 100</i>	M	ØD [mm]	Gewicht [g] <i>Weight [g]</i>	Teil-Nr <i>Part#</i>
pulverbeschichtet <i>Powder coated</i>	M10	11 (M10)	310.0	093T501001010S
	M10	14.5 (M12)	296.0	093T501001012S
	M12	11 (M10)	306.0	093T501001210S
	M12	14.5 (M12)	292.0	093T501001212S
	M14	11 (M10)	300.0	093T501001410S
	M14	14.5 (M12)	286.0	093T501001412S
	M16	11 (M10)	296.0	093T501001610S
	M16	14.5 (M12)	280.0	093T501001612S
	M20	11 (M10)	289.0	093T501002010S
	M20	14.5 (M12)	273.0	093T501002012S
blank <i>Plain</i>	M10	11 (M10)	310.0	093T501001010R
	M10	14.5 (M12)	296.0	093T501001012R
	M12	11 (M10)	306.0	093T501001210R
	M12	14.5 (M12)	292.0	093T501001212R
	M14	11 (M10)	300.0	093T501001410R
	M14	14.5 (M12)	286.0	093T501001412R
	M16	11 (M10)	296.0	093T501001610R
	M16	14.5 (M12)	280.0	093T501001612R
	M20	11 (M10)	289.0	093T501002010R
	M20	14.5 (M12)	273.0	093T501002012R



TRANSPORT- UND FUßPLATTE 100 × 100

TRANSPORT AND BASE PLATE 100 × 100

Ausführung	Zinkdruckguss	Model	Zinc die-cast
Beschreibung	zur Aufnahme von Stellfüßen, Rollen, Haken oder ähnlichen Bauteilen; stirnseitig mit den Profilen verschraubbar	Description	To mount leveling feet, rollers, hooks or similar components; screw joint to the face of the profile
Material	Zinkdruckguss	Material	Zinc die-cast
Liefereinheit	10 Stück	Pack Quantity	10 pieces
Extras	weitere Oberflächen, weitere Farben auf Anfrage	Specials	Other surfaces, other colors on request

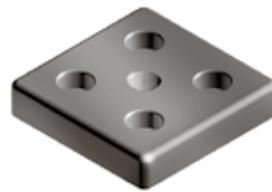
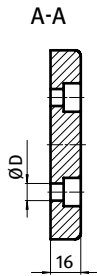
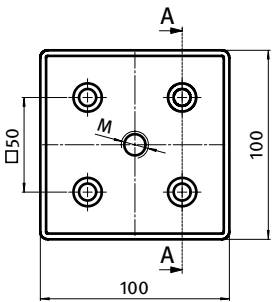

Transport- und Fußplatte 100 × 100 <i>Transport and Base Plate 100 × 100</i>	M	ØD [mm]	Gewicht [g] <i>Weight [g]</i>	Teil-Nr <i>Part#</i>
pulverbeschichtet <i>Powder coated</i>	M10	9 (M8)	548.0	093T1001001008S
	M10	14.5 (M12)	541.0	093T1001001012S
	M12	9 (M8)	545.0	093T1001001208S
	M12	14.5 (M12)	538.0	093T1001001212S
	M14	9 (M8)	541.0	093T1001001408S
	M14	14.5 (M12)	531.0	093T1001001412S
	M16	9 (M8)	540.0	093T1001001608S
	M16	14.5 (M12)	527.0	093T1001001612S
	M20	9 (M8)	531.0	093T1001002008S
	M20	14.5 (M12)	521.0	093T1001002012S
blank <i>Plain</i>	M10	9 (M8)	548.0	093T1001001008R
	M10	14.5 (M12)	541.0	093T1001001012R
	M12	9 (M8)	545.0	093T1001001208R
	M12	14.5 (M12)	538.0	093T1001001212R
	M14	9 (M8)	541.0	093T1001001408R
	M14	14.5 (M12)	531.0	093T1001001412R
	M16	9 (M8)	540.0	093T1001001608R
	M16	14.5 (M12)	527.0	093T1001001612R
	M20	9 (M8)	531.0	093T1001002008R
	M20	14.5 (M12)	521.0	093T1001002012R



BODENWINKEL 140, 1 NUT

FLOOR BRACKET 140, 1 SLOT VERSION

Ausführung	Aluminium	Model	Aluminum
Beschreibung	zur festen Verbindung von Aluminiumprofilen mit dem Boden	Description	To securely fix aluminum profiles to the floor
Material	Aluminium	Material	Aluminum
Liefereinheit	10 Stück	Pack Quantity	10 pieces

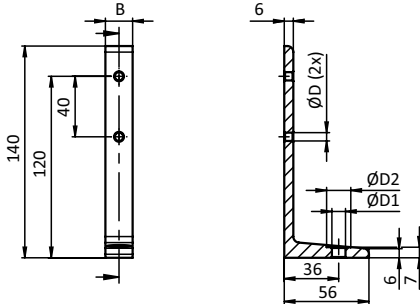

Bodenwinkel 140, 1 Nut Floor Bracket 140, 1 Slot Version	B [mm]	ØD [mm]	ØD1 [mm]	ØD2 [mm]	für Profil For Profile	Gewicht [g] Weight [g]	Teil-Nr. Part #
	18.0	5.5	9.0	16.0	20	57.0	093BA14020
	23.0 (0.91")	7.0	9.0	16.0	25	74.5	093BA14025
	27.0	7.0	11.0	22.0	30	92.0	093BA14030
	34.0 (1.3")	9.0	13.5	28.0	38	107.6	093BA14038
	36.0	9.0	13.5	28.0	40	111.0	093BA14040
	41.0	9.0	13.5	29.5	45	127.0	093BA14045

1



BODENWINKEL 140, 2 NUTEN

FLOOR BRACKET 140, 2 SLOT VERSION

Ausführung	Aluminium	Model	Aluminum
Beschreibung	zur festen Verbindung von Aluminiumprofilen mit dem Boden	Description	To securely fix aluminum profiles to the floor
Material	Aluminium	Material	Aluminum
Liefereinheit	10 Stück	Pack Quantity	10 pieces

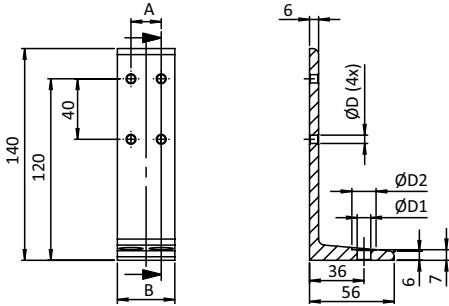

Bodenwinkel 140, 2 Nuten <i>Floor Bracket 140, 2 Slot Version</i>	A [mm]	B [mm]	ØD [mm]	ØD1 [mm]	ØD2 [mm]	für Profil <i>For Profile</i>	Gewicht [g] <i>Weight [g]</i>	Teil-Nr. <i>Part #</i>
	38.0	20.0	5.5	9.0	16.0	20	119.0	093BA140D40
	57.0	30.0	7.0	11.0	22.0	30	178.5	093BA140D60
	72.0	38.0	9.0	13.5	28.0	38	225.0	093BA140D76
	76.0	40.0	9.0	13.5	28.0	40	236.0	093BA140D80
	86.0	45.0	9.0	13.5	28.0	45	267.0	093BA140D90



BODENWINKEL 30

FLOOR BRACKET 30

Ausführung	Aluminiumdruckguss, ab Profil 30	Model	Aluminum die-cast, profile 30 and up
Beschreibung	zur festen Verbindung von Aluminiumprofilen mit dem Boden, zusätzlich auch zur rechtwinkligen Verbindung von zwei Aluminiumprofilen einsetzbar	Description	To securely fix aluminum profiles to the floor, can also be used to connect two aluminum profiles at right angles
Material	Bodenwinkel: Aluminiumdruckguss Abdeckkappe: Kunststoff PA, glasfaserverstärkt Nutfixierung: Kunststoff PA, glasfaserverstärkt	Material	Floor bracket: Aluminum die-cast Cover cap: Plastic PA, glass fiber reinforced Centering piece: Plastic PA, glass fiber reinforced
Farbe	Abdeckkappe: schwarz Nutfixierung: schwarz	Color	Cover cap: Black Centering piece: Black
Liefereinheit	11 Stück	Pack Quantity	11 pieces
Extras	weitere Oberflächen, weitere Farben auf Anfrage	Specials	Other surfaces, other colors on request

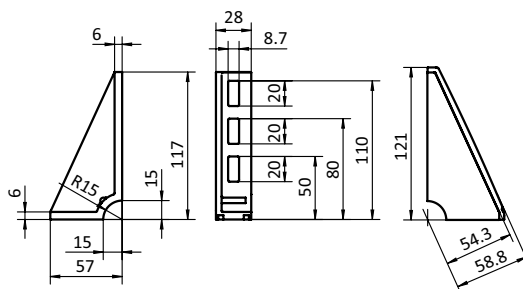

Bodenwinkel 30 Floor Bracket 30	N	Gewicht [g] Weight [g]	Teil-Nr. Part #
		90.4	093W1171L
	6	90.6	093W1171LN06
	8	90.7	093W1171LN08
Nutfixierung Centering piece	Nut 8 auf Nut 10 Slot 8 to Slot 10	1.0	093W03
Abdeckkappe Cover cap		23.0	093WA1171L

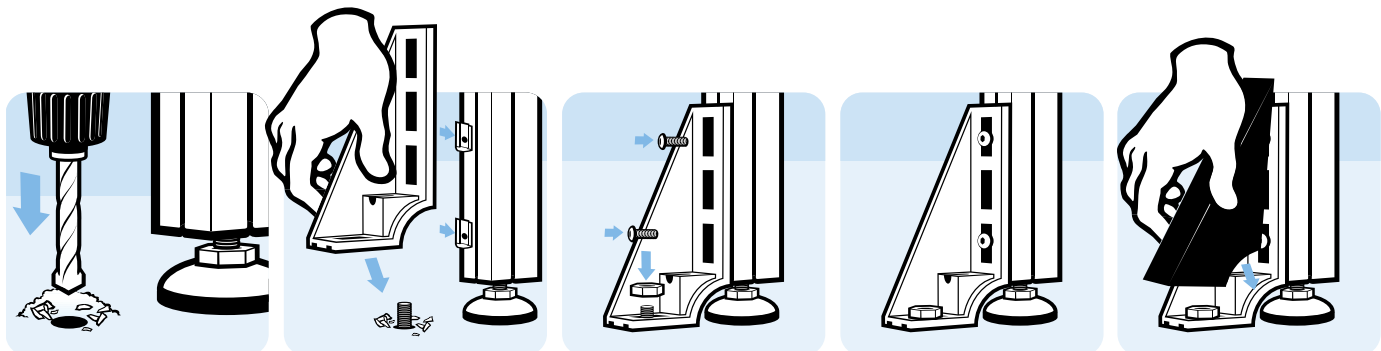



BODENWINKEL 45

FLOOR BRACKET 45

Ausführung	Aluminiumdruckguss, ab Profil 45	Model	Aluminum die-cast, profile 45 and up
Beschreibung	zur festen Verbindung von Aluminiumprofilen mit dem Boden, zusätzlich auch zur rechtwinkligen Verbindung von zwei Aluminiumprofilen einsetzbar	Description	To securely fix aluminum profiles to the floor, can also be used to connect two aluminum profiles at right angles
Material	Aluminiumdruckguss	Material	Aluminum die-cast
Liefereinheit	10 Stück	Pack Quantity	10 pieces
Extras	weitere Oberflächen, weitere Farben auf Anfrage	Specials	Other surfaces, other colors on request

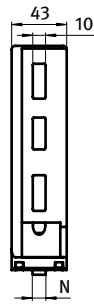
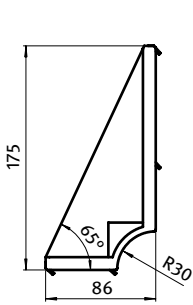

Bodenwinkel 45
Floor Bracket 45

N

Gewicht [g]
Weight [g]

Teil-Nr.
Part #

10

283.0

093W1751LN10

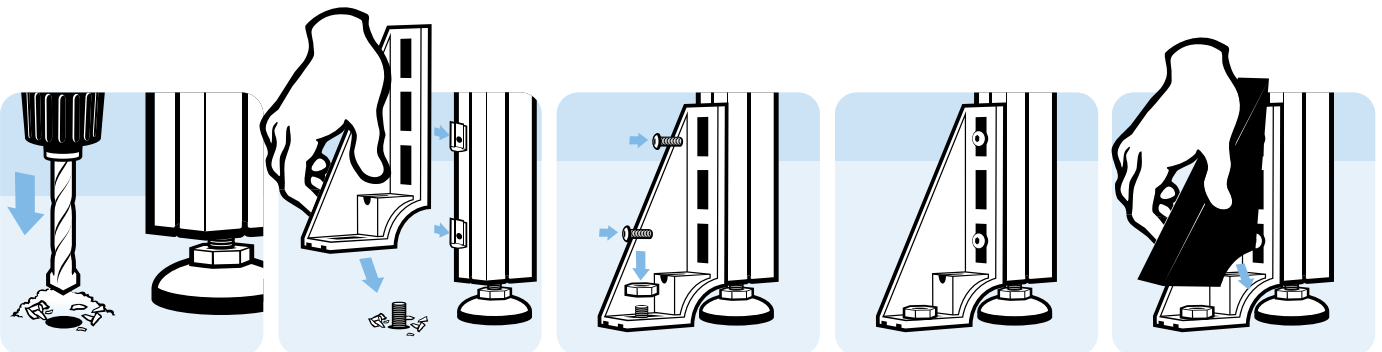



BODENWINKEL 120

FLOOR BRACKET 120

Ausführung	Zinkdruckguss, ab Profil 30	Model	Zinc die-cast, profile 30 and up
Beschreibung	zur festen Verbindung von Aluminiumprofilen mit dem Boden	Description	To securely fix aluminum profiles to the floor
Material	Bodenwinkel: Zinkdruckguss, Montageset: Stahl	Material	Floor bracket: Zinc die-cast Assembly set: Steel
Montageset	1 Bodenwinkel 120, 1 Nutenstein - Nut 6 - M6, 1 Schraube ISO 7380 - M6 x 12	Assembly Set	1 floor bracket 120, 1 T-slot nut - Nut 6 - M6, 1 screw ISO 7380 - M6 x 12
Liefereinheit	10 Stück	Pack Quantity	10 pieces
Extras	weitere Oberflächen, weitere Farben auf Anfrage	Specials	Other surfaces, other colors on request

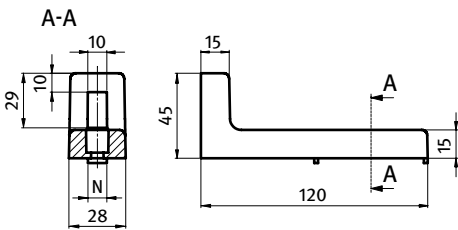

Bodenwinkel 120 Floor Bracket 120	N	Gewicht [g] Weight [g]	Profil Profile	Teil-Nr. Part #
blank <i>Plain</i>	6	190.0		093B1201N06R
	8	190.0		093B1201N08R
pulverbeschichtet <i>Powder coated</i>	10	190.0		093B1201N10R
	6	190.0		093B1201N06S
	8	190.0		093B1201N08S
	10	190.0		093B1201N10S
pulverbeschichtet, inkl. Montageset <i>Powder coated, with assembly set</i>	6	198.1	I	093B1201N06SS02

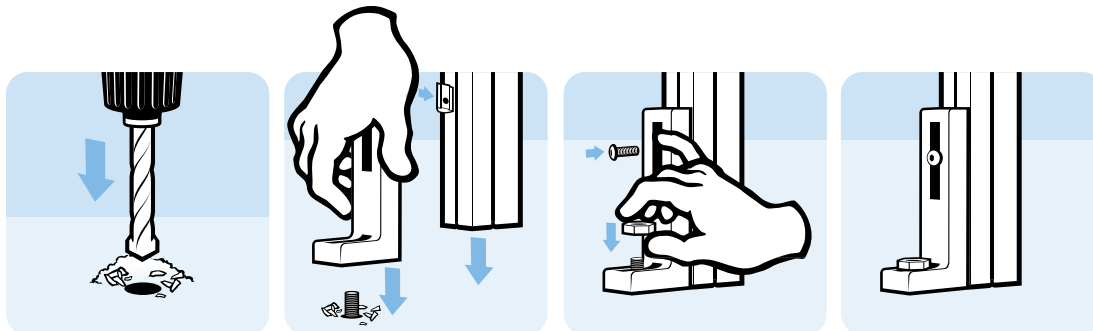



BODENWINKEL 120, HÖHENVERSTELLBAR

ADJUSTABLE FLOOR BRACKET 120

Ausführung	Zinkdruckguss, ab Profil 30	Model	Zinc die-cast, profile 30 and up
Beschreibung	zur höhenverstellbaren Verbindung von Aluminiumprofilen mit dem Boden, inkl. Justierschraube und Gewindeplatte	Description	To fix aluminum profiles to the floor vertically adjustable; with adjustment screw and threaded plate
Material	Bodenwinkel: Zinkdruckguss Montageset: Stahl	Material	Floor bracket: Zinc die-cast Assembly set: Steel
Montageset	1 Bodenwinkel 120, 1 Nutenstein - Nut 6 - M6, 1 Schraube ISO 7380 - M6 × 12	Assembly Set	1 floor bracket 120, 1 T-slot nut - Nut 6 - M6, 1 screw ISO 7380 - M6 × 12
Liefereinheit	10 Stück	Pack Quantity	10 pieces
Extras	weitere Oberflächen, weitere Farben auf Anfrage	Specials	Other surfaces, other colors on request

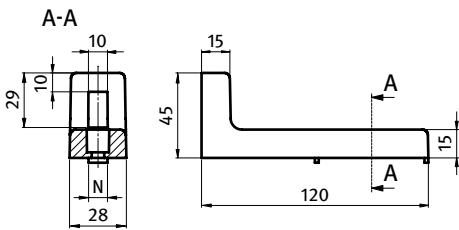

Bodenwinkel 120, höhenverstellbar
Adjustable Floor Bracket 120

	N	Hubhöhe [mm] <i>Lifting Height [mm]</i>	Gewicht [g] <i>Weight [g]</i>	Profil <i>Profile</i>	Teil-Nr. <i>Part #</i>
blank <i>Plain</i>	6	52.0	88.0		093B1201N06RS01
	8	52.0	88.0		093B1201N08RS01
	10	52.0	88.0		093B1201N10RS01
pulverbeschichtet <i>Powder coated</i>	6	52.0	88.0		093B1201N06SS01
	8	52.0	88.0		093B1201N08SS01
	10	52.0	88.0		093B1201N10SS01
pulverbeschichtet, inkl. Montageset <i>Powder coated, with assembly set</i>	6	52.0	96.3	I	093B1201N06SS03

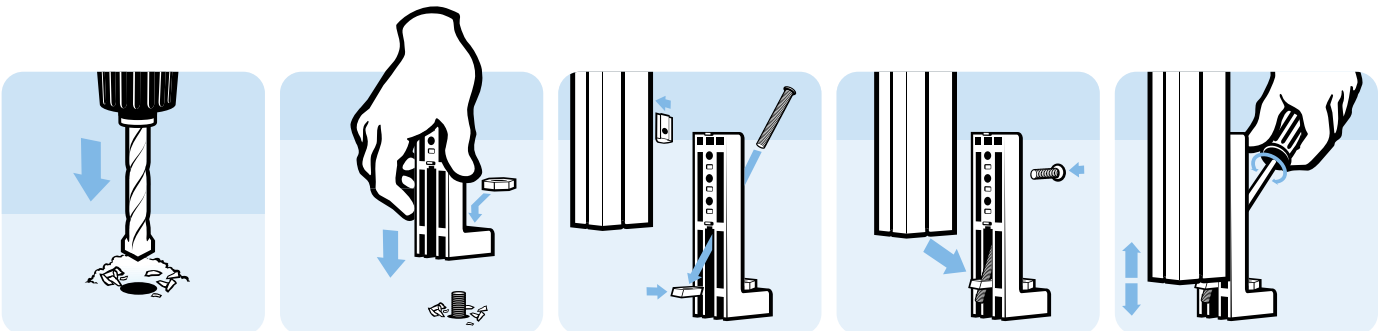



BODENWINKEL 160

FLOOR BRACKET 160

Ausführung	Zinkdruckguss, ab Profil 40	Model	Zinc die-cast, profile 40 and up
Beschreibung	zur festen Verbindung von Aluminiumprofilen mit dem Boden	Description	To securely fix aluminum profiles to the floor
Material	Bodenwinkel: Zinkdruckguss Montageset: Stahl	Material	Floor bracket: Zinc die-cast Assembly set: Steel
Montageset	1 Bodenwinkel 160, 1 Nutenstein - Nut 8 - M8, 1 Schraube ISO 7380 - M8 x 16	Assembly Set	1 floor bracket 160, 1 T-slot nut - Nut 8 - M8, 1 screw ISO 7380 - M8 x 16
Liefereinheit	10 Stück	Pack Quantity	10 pieces
Extras	weitere Oberflächen, weitere Farben auf Anfrage	Specials	Other surfaces, other colors on request

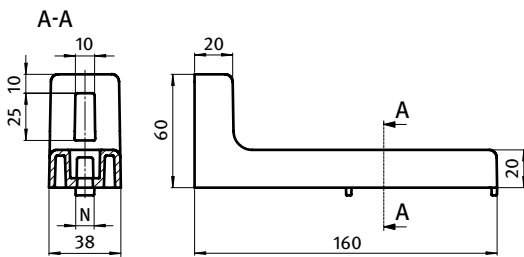

Bodenwinkel 160 Floor Bracket 160	N	Gewicht [g] Weight [g]	Profil Profile	Teil-Nr. Part #
blank Plain	8	110.0		093B1601N08R
	10	110.0		093B1601N10R
pulverbeschichtet Powder coated	8	110.0		093B1601N08S
	10	110.0		093B1601N10S
pulverbeschichtet, inkl. Montageset Powder coated, with assembly set	8	535.0	I	093B1601N08SS05

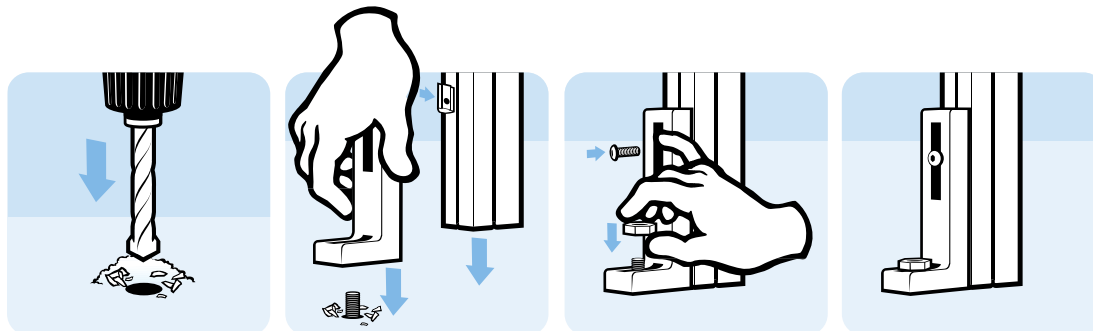



BODENWINKEL 160, HÖHENVERSTELLBAR

ADJUSTABLE FLOOR BRACKET 160

Ausführung	Zinkdruckguss, ab Profil 40	Model	Zinc die-cast, profile 40 and up
Beschreibung	zur höhenverstellbaren Verbindung von Aluminiumprofilen mit dem Boden, inkl. Justierschraube und Gewindeplatte	Description	To fix aluminum profiles to the floor vertically adjustable; with adjustment screw and threaded plate
Material	Bodenwinkel: Zinkdruckguss Montageset: Stahl	Material	Floor bracket: Zinc die-cast Assembly set: Steel
Montageset	1 Bodenwinkel 160 höhenverstellbar, 1 Nutstein - Nut 8 - M8, 1 Schraube ISO 7380 - M8 × 16	Assembly Set	1 adjustable floor bracket 160, 1 T-slot nut - Nut 8 - M8, 1 screw ISO 7380 - M8 × 16
Liefereinheit	10 Stück	Pack Quantity	10 pieces
Extras	weitere Oberflächen, weitere Farben auf Anfrage	Specials	Other surfaces, other colors on request

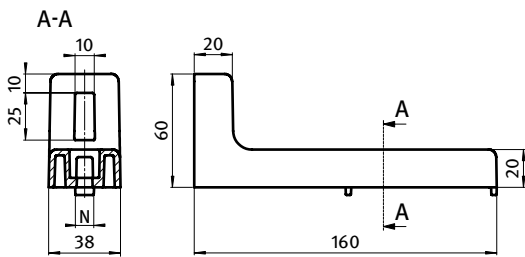

Bodenwinkel 160, höhenverstellbar
Adjustable Floor Bracket 160

	N	Hubhöhe [mm] <i>Lifting Height [mm]</i>	Gewicht [g] <i>Weight [g]</i>	Profil <i>Profile</i>	Teil-Nr. <i>Part #</i>
blank <i>Plain</i>	8	72.0	505.0		093B1601N08RS01
	10	72.0	510.0		093B1601N10RS01
pulverbeschichtet <i>Powder coated</i>	8	72.0	505.0		093B1601N08SS01
	10	72.0	510.0		093B1601N10SS01
pulverbeschichtet, inkl. Montageset <i>Powder coated, with assembly set</i>	8	72.0	535.0	I	093B1601N08SS02

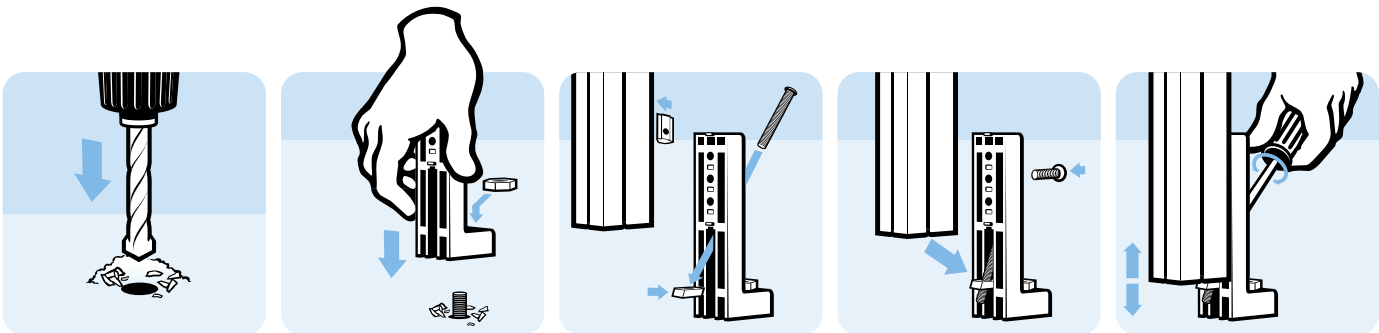



BODENWINKEL 200

FLOOR BRACKET 200

Ausführung	Stahl, ab Profil 40	Model	Steel, profile 40 and up
Beschreibung	zur festen Verbindung von Aluminiumprofilen mit dem Boden	Description	To securely fix aluminum profiles to the floor
Material	Stahl	Material	Steel
Liefereinheit	10 Stück	Pack Quantity	10 pieces
Extras	weitere Oberflächen, weitere Farben auf Anfrage	Specials	Other surfaces, other colors on request

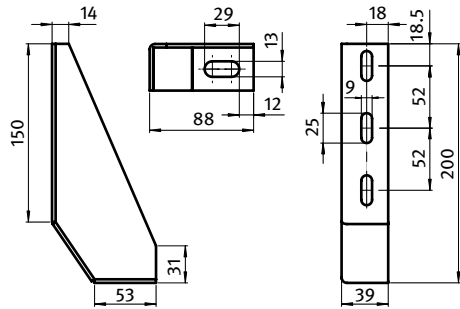

Bodenwinkel 200
Floor Bracket 200

Gewicht [g]
Weight [g]

Teil-Nr.
Part #

verzinkt <i>Zinc plated</i>	456.0	093B2001V
pulverbeschichtet <i>Powder coated</i>	456.0	093B2001S

1



BODENWINKEL 160

FLOOR BRACKET 160

Ausführung	Stahl, ab Profil 45	Model	Steel, profile 45 and up
Beschreibung	zur festen Verbindung von Aluminiumprofilen mit dem Boden	Description	To securely fix aluminum profiles to the floor
Material	Stahl	Material	Steel
Liefereinheit	10 Stück	Pack Quantity	10 pieces
Extras	weitere Oberflächen, weitere Farben auf Anfrage	Specials	Other surfaces, other colors on request

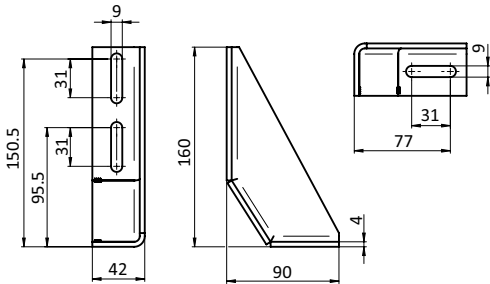

Bodenwinkel 160
Floor Bracket 160

Gewicht [g]
Weight [g]

Teil-Nr.
Part #

verzinkt <i>Zinc plated</i>	423.0	093B2002V
pulverbeschichtet <i>Powder coated</i>	423.0	093B2002S

PFOSTENKONSOLE

FLOOR MOUNT BASE

Ausführung Aluminiumdruckguss
Beschreibung für die Aufnahme von Profilen, um Pfosten zu setzen
Material Aluminiumdruckguss
Liefereinheit 10 Stück
Hinweis passender Doppelnutenstein für Pfostenkonsole siehe Seite 118

Model Aluminum die-cast
Description To mount aluminum profiles as posts
Material Aluminum die-cast
Pack Quantity 10 pieces
Tip Compatible double T-slot nut for floor mount base see page 118

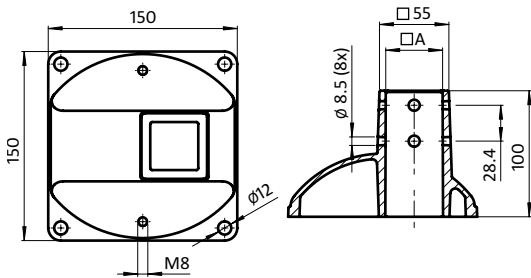

Pfostenkonsole
Floor Mount Base

für Profil
For Profile

Gewicht [g]
Weight [g]

Teil-Nr.
Part #

A = 38,3 × 38,3 (1.5" × 1.5")	A = 38.3 × 38.3 (1.5" × 1.5")	980.0	098G38150A
	A = 40 × 40	940.0	098G40150A
	A = 45 × 45	820.0	098G45150A

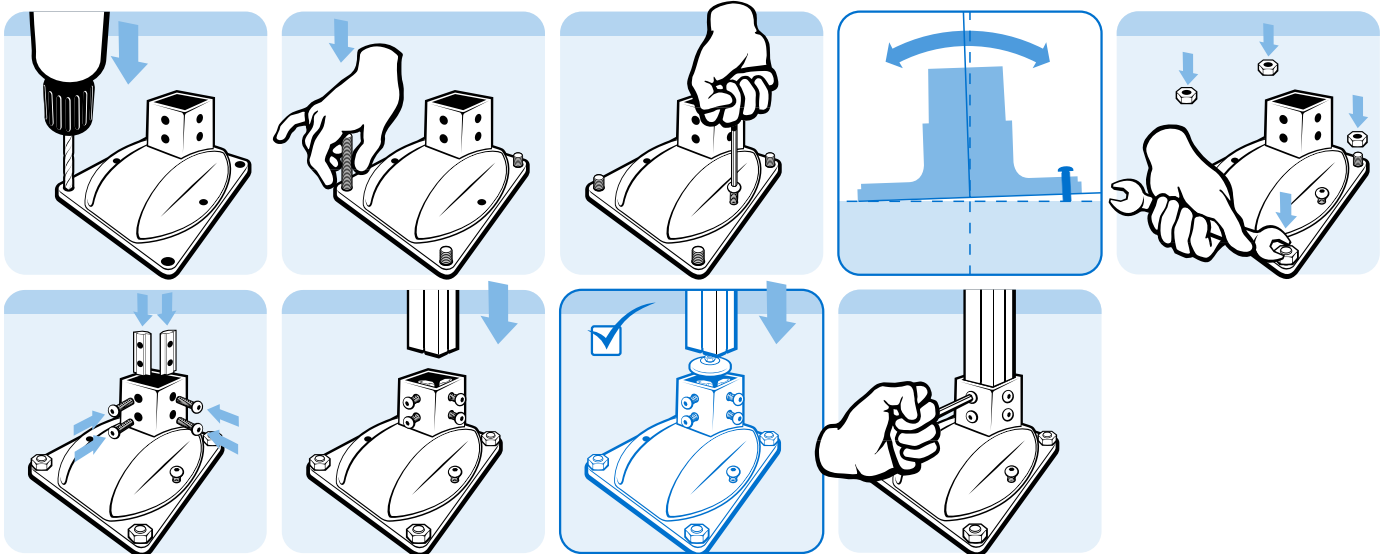



DOPPELNUTENSTEIN FÜR PFOSTENKONSOLE

DOUBLE T-SLOT NUT FOR FLOOR MOUNT BASE

Ausführung	mit Führungssteg, Stahl	Model	Self-aligning, Steel
Beschreibung	Doppelnutenstein	Description	Double T-slot nut
Material	Stahl, verzinkt	Material	Steel, zinc plated
Liefereinheit	100 Stück	Pack Quantity	100 pieces
Extras	verschiedene Längen mit mehreren Gewinden in unterschiedlichen Größen auf Anfrage	Specials	Different lengths with multiple threads in different sizes available on request

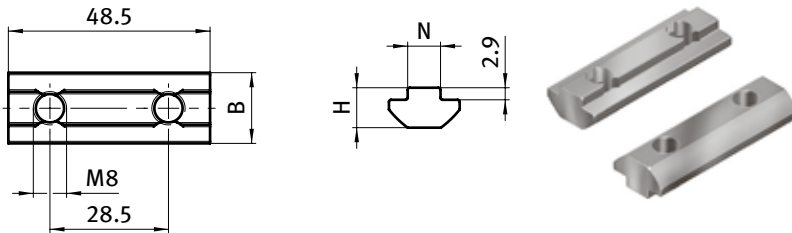

Doppelnutenstein <i>Double T-slot Nut</i>	B [mm]	H [mm]	N	Gewicht [g] <i>Weight [g]</i>	Profil <i>Profile</i>	Teil-Nr <i>Part#</i>
Nut 8 <i>Slot 8</i>	17.0	9.6	7.9	39.0	I	096060S54
Nut 10 <i>Slot 10</i>	19.0	10.6	9.8	49.5	B	096030S41



FUBKONSOLE 45/60 - 120

FOOT CONSOLE 45/60 - 120

Ausführung Aluminiumdruckguss
Beschreibung für die Aufnahme von Profilen, um Pfosten zu setzen
Material Aluminiumdruckguss
Liefereinheit 10 Stück
Hinweis passende Hammerschraube M8 × 30 siehe Seite 299;
 passende Flanschmutter M8 siehe Seite 301

Model Aluminum die-cast
Description To mount aluminum profiles as posts
Material Aluminum die-cast
Pack Quantity 10 pieces
Tip Compatible hammer screw M8 × 30 see page 299;
 Compatible flange nut see page 301

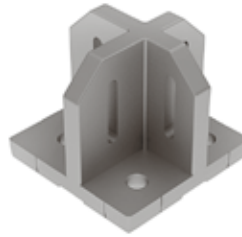
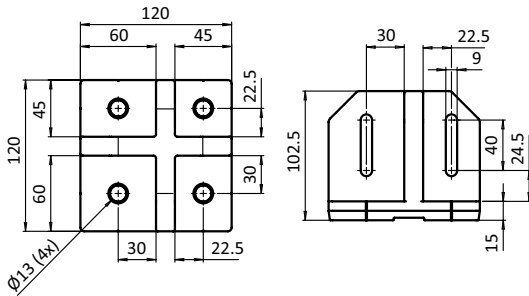

Fußkonsole
 Foot Console

Gewicht [g]
 Weight [g]

Teil-Nr.
 Part #

1083.0

098G4560X120A

1



FUßKONSOLE 45/90 - 150

FOOT CONSOLE 45/90 - 150

<p>Ausführung Aluminiumdruckguss</p> <p>Beschreibung für die Aufnahme von Profilen, um Pfosten zu setzen</p> <p>Material Aluminiumdruckguss</p> <p>Liefereinheit 10 Stück</p> <p>Hinweis passende Hammerschraube M8 × 30 siehe Seite 299; passende Flanschmutter M8 siehe Seite 301</p>	<p>Model Aluminum die-cast</p> <p>Description To mount aluminum profiles as posts</p> <p>Material Aluminum die-cast</p> <p>Pack Quantity 10 pieces</p> <p>Tip Compatible hammer screw M8 × 30 see page 299; Compatible flange nut see page 301</p>
--	---

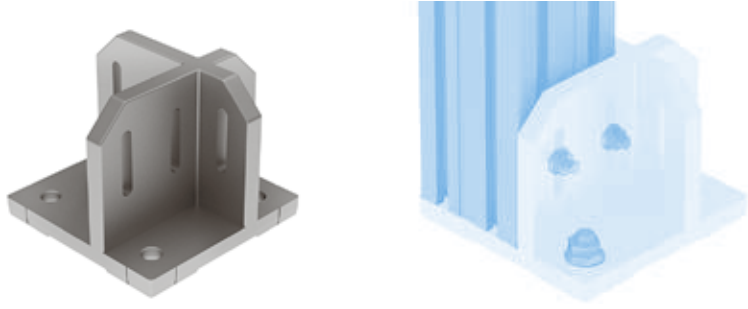
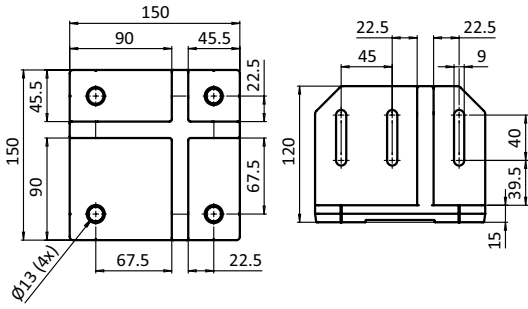

Fußkonsole
Foot Console

Gewicht [g]
Weight [g]

Teil-Nr.
Part #

1719.0

098G4590X150A



FUßPLATTE 45 / 60 / 90 - 135

FOOT PLATE 45 / 60 / 90 - 135

Beschreibung für die Aufnahme von Profilen, um Pfosten zu setzen
Material Aluminiumdruckguss
Oberfläche Blank
Liefereinheit 10 Stück
Hinweis passende selbstformende Schraube siehe Seite 419, passende Verbinderschrauben siehe Seite 421

Description To mount aluminum profiles as posts
Material Die-cast aluminum
Surface Plain
Pack Quantity 10 pieces
Tip Compatible self forming screw see page 419, compatible connecting screws see page 421

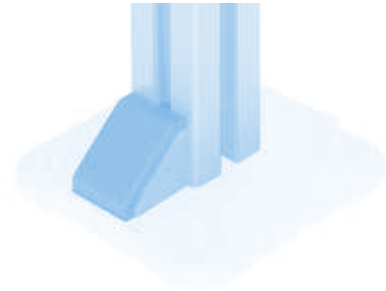
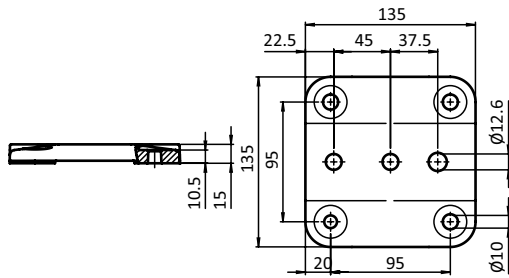

Fußplatte 45 / 60 / 90 - 135
 Foot Plate 45 / 60 / 90 - 135

Gewicht [g]
 Weight [g]

Teil-Nr.
 Part #

348.0

098G4560X135A

1

LENK- & BOCKROLLEN

- drei verschiedene Raddurchmesser / Bauhöhen
- zwei verschiedene Befestigungen
- vier verschiedene Materialien, drei davon auch in ESD-Ausführung
- Gehäuse und Adapterplatten sind alufarbig pulverbeschichtet, passend zu eloxiertem Aluminium
- alle Lenkrollen werden mit Doppelfeststeller geliefert, die Arretierung verhindert ein Rollen und Drehen des Rades
- Bockrollen haben keine Feststeller
- Befestigung mittels spezieller Adapterplatten oder integrierter Montageplatten
- formschlüssige und verdrehgesicherte Befestigung ohne seitlichen Überstand an Aluprofilen mit Rastermaß 38 mm - 1.5" 40 mm und 45 mm

In Zusammenarbeit mit Marktführer Blickle hat FATH diese Lenk- und Bockrollen speziell für den Einsatz mit Aluprofil-Systemen entwickelt. Alle Gehäuse und Adapterplatten sind alufarbig pulverbeschichtet und passen damit hervorragend zur Oberfläche von eloxierten Aluprofilen.

FATH bietet entweder Rollen konventioneller Form mit Adapterplatten an oder Rollen mit integrierter Montageplatte. Damit ist eine schnelle, verdrehgesicherte Montage an Aluprofilen – ohne seitlichen Überstand – sichergestellt.

SWIVEL AND FIXED CASTORS

- Three different wheel diameters / mounting heights
- Two different mounting methods
- Four different materials, three of the also as ESD version
- Housing and adapter plates are alu color powder coated, thus matching with anodized aluminum surfaces
- All swivel rollers are delivered with double-brake, the locking prevents turning of the wheel as well as swiveling
- Fixed castors are without brake
- Mounting either with adapter plates or with integrated mounting plates
- Positive-locking anti-twist attachment without lateral overlap to aluminum profiles of modular dimensions 38 mm - 1.5" 40 mm und 45 mm

In cooperation with market leader Blickle, FATH has designed these swivel and fixed castors especially for use with aluminum profile systems. All housings and adapter plates are alu color powder coated and match perfectly with anodized aluminum profiles.

FATH offers castors in conventional design with adapter plates as well as castors with integrated mounting plate. Thereby a fast attachment to aluminum profiles, anti-twist and without lateral overlap, is made possible.

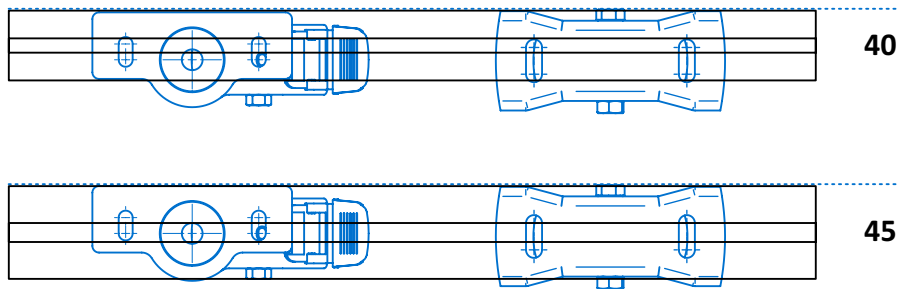

Die integrierten Montageplatten und die Adapterplatten sind mit Langlöchern versehen. Die Anschraubplatte der Lenkrolle ist zudem asymmetrisch.

Adapter plates are equipped with oblong holes. Additionally, the adapter plate of the swivel castor has an asymmetrical design.



	TPE	TPE	TPU	TPU	Vollgummi	Vollgummi	PA
	bodenschonend Floor-protecting		nachgiebig Pliable		hohe Rückformelastizität High deformation elasticity		chemisch beständig* Chemical resistant*
Track marks <i>Spuren</i>	nein <i>No</i>		nein <i>No</i>		ja <i>Yes</i>		nein <i>No</i>
Shore hardness <i>Shorehärte</i>	85° Shore A		94° Shore A		80° Shore A		70° Shore D
elektrostatisch entladend electrostatically discharging							
Farbe Radkörper Color of wheel body	grau Gray	schwarz Black	grau Gray	schwarz Black	grau Gray	schwarz Black	schwarz Black
Farbe Lauffläche Color of wheel tread	grau Gray	grau Gray	schwarz Black	schwarz Black	grau Gray	schwarz Black	schwarz Black
Rollwiderstand Rolling resistance	* * * *		* * * *		* * *		* * * * *
Fahrgeräusch Rolling noise	* * *		* * *		* * * *		* *
Bodenschonung Floor protection	* * *		* * *		* * * *		* *

* beständig gegen erdöl- und alkoholbasierte Lösungsmittel / Resistant to petroleum and alcohol based solvents



LENK- & BOCKROLLEN

Empfohlenes Montagematerial

Stirnseitig im Kernloch mittels Adapterplatte:

I 40:

- 1 Schraube - M8 x 40;
- 1 Scheibe DIN EN ISO 7093 - 8.4

B 40, B 45:

- 1 Schraube - M12 x 40
- 1 selbstfurchende Schraube - S12 x 40

Längs zur Profilnut mittels Adapterplatte:

I 40:

- 1 Schraube M8 x 25;
- 1 Scheibe DIN EN ISO 7093 - 8.4;
- 1 Nutenstein Nut 8 - M8

I 45:

- 1 Hammerschraube M8 x 30;
- 1 Scheibe DIN EN ISO 7093 - 8.4;
- 1 Mutter DIN EN ISO 10511 - M8

B 40, B 45:

- T-Bolzen M12 x 30;
- 1 Mutter DIN EN ISO 10511 - M12

Längs zur Profilnut mittels Rückenlochung:

I 40:

- 1 Schraube M8 x 14;
- 1 Nutenstein Nut 8 - M8

B 40, B 45:

- 1 Schraube M8 x 14;
- 1 Nutenstein Nut 10 - M8

SWIVEL AND FIXED CASTORS

Recommendend Mounting Material

On the face side in a core hole, using the adapter plate:

I 40:

- 1 screw - M8 x 40;
- 1 washer DIN EN ISO 7093 - 8.4

B 40, B 45:

- 1 screw - M12 x 40
- 1 self-tapping screw - S12 x 40

Along the T-slot, using the adapter plate:

I 40:

- 1 screw M8 x 25;
- 1 washer DIN EN ISO 7093 - 8.4;
- 1 T-slot nut slot 8 - M8

I 45:

- 1 hammer screw M8 x 30;
- 1 washer DIN EN ISO 7093 - 8.4;
- 1 nut DIN EN ISO 10511 - M8

B 40, B 45:

- T-bolt M12 x 30;
- 1 nut DIN EN ISO 10511 - M12

Along the T-slot, using the bolt holes:

I 40:

- 1 screw M8 x 14;
- 1 T-slot nut slot 8 - M8

B 40, B 45:

- 1 screw M8 x 14;
- 1 T-slot nut slot 10 - M8

Bodenelemente *Floor Elements*

Lenk- & Bockrollen *Swivel and Fixed Castors*

Lenkrollen *Swivel Castors*



LENKROLLE

SWIVEL CASTOR

Ausführung	mit Rückenloch und Doppelfeststeller; für optionale Adapterplatte S	Model	With bolt hole and system brake; compatible with optional adapter plate S
Beschreibung	belastbare und laufruhige Lenkrolle, spurlos (außer Vollgummi elektrostatisch entladend), kugelgelagert* mit Fadenschutz; zur Befestigung an Aluminiumprofilen; kombinierbar mit allen Lenk- und Bockrollen durch gleiches Höhenniveau mit optionaler Adapterplatte S; keine zusätzliche Transport- und Fußplatte notwendig	Description	Reliable and quiet swivel castor, trackless (except solid rubber electrostatically discharging), with ball bearings* and thread guard; can be fixed to aluminum profiles; compatible with all swivel and fixed castors due to consistent height level with optional adapter plate S; no additional transport and base plate needed
Material	Gehäuse: Stahl Laufbelag: siehe Tabelle Radkörper: siehe Tabelle Adapterplatte: Zinkdruckguss	Material	Housing: Steel Tread: See table Wheel body: See table Adapter plate: Zinc die-cast
Farbe	Gehäuse: alufarbig Laufbelag: siehe Tabelle Radkörper: schwarz, grau ≈ RAL 7001 Adapterplatte: alufarbig	Color	Housing: Alu color Tread: See table Wheel body: Black, gray ≈ RAL 7001 Adapter plate: Alu color
Liefereinheit	1 Stück	Pack Quantity	1 piece
Extras	weitere Rollenarten, weitere Farben, weitere Oberflächen auf Anfrage	Specials	Other kinds of wheels, other colors, other surfaces on request

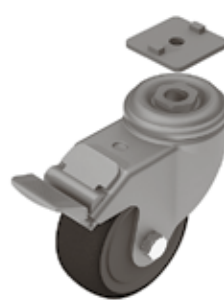
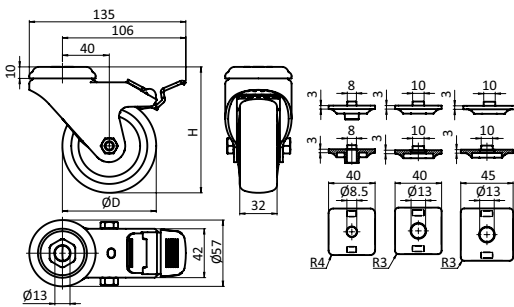

Lenkrolle Laufbelag <i>Swivel Castor Tread</i>	D [mm]	H [mm]	ESD	Radkörper <i>Wheel Body</i>	Tragkraft [N] <i>Max. Load [N]</i>	Gewicht [g] <i>Weight [g]</i>	Teil-Nr. <i>Part #</i>
TPE, grau ≈ RAL 7031 <i>TPE, gray</i>	80	108		PP, grau <i>PP, gray</i>	1000	597.0	098S080TDN
	100	133		PP, grau <i>PP, gray</i>	1100	674.0	098S100TDN
	125	158		PP, grau <i>PP, gray</i>	1200	760.0	098S125TDN
	80	108		PP, schwarz <i>PP, black</i>	650	627.0	098S080TDNESD
	100	133		PP, schwarz <i>PP, black</i>	700	723.0	098S100TDNESD
	125	158		PP, schwarz <i>PP, black</i>	800	824.0	098S125TDNESD
TPU, grau ≈ RAL 7024 <i>TPU, gray</i>	80	108		PA, grau <i>PA, gray</i>	1200	627.0	098S080UDN
	100	133		PA, grau <i>PA, gray</i>	1200	685.0	098S100UDN
	125	158		PA, grau <i>PA, gray</i>	1200	773.0	098S125UDN
	80	108		PA, schwarz <i>PA, black</i>	1000	610.0	098S080UDNESD
	100	133		PA, schwarz <i>PA, black</i>	1200	736.0	098S100UDNESD
	125	158		PA, schwarz <i>PA, black</i>	1200	843.0	098S125UDNESD
Vollgummi, grau ≈ RAL 7001 <i>Solid rubber, gray</i>	80	108		PA, schwarz <i>PA, black</i>	800	627.0	098S080GDN
	100	133		PA, schwarz <i>PA, black</i>	1100	772.0	098S100GDN
	125	158		PA, schwarz <i>PA, black</i>	1000	893.0	098S125GDN
Vollgummi, schwarz <i>Solid rubber, black</i>	80	108		PA, schwarz <i>PA, black</i>	600	610.0	098S080GDNESD
	100	133		PA, schwarz <i>PA, black</i>	800	736.0	098S100GDNESD
	125	158		PA, schwarz <i>PA, black</i>	750	843.0	098S125GDNESD
PA, schwarz; *gleitgelagert <i>PA, black; *with slide bearings</i>	80	108		PA, schwarz <i>PA, black</i>	1000	535.0	* 098S080ADN
	100	133		PA, schwarz <i>PA, black</i>	1200	661.0	098S100ADN
	125	158		PA, schwarz <i>PA, black</i>	1200	728.0	098S125ADN



LENKROLLE MIT INTEGRIERTER ANSCHRAUBPLATTE

SWIVEL CASTOR WITH MOUNTING PLATE 40 / 45

Ausführung	mit Rückenlochung und Doppelfeststeller	Model	With bolt hole pattern and system brake
Beschreibung	belastbare und laufruhige Lenkrolle, spurlos (außer Vollgummi elektrostatisch entladend), kugelgelagert* mit Fadenschutz und integrierter Anschraubplatte zur asymmetrischen Befestigung an Aluminiumprofilen ohne Überstand; kombinierbar mit allen Lenk- und Bockrollen durch gleiches Höhenniveau; keine zusätzliche Transport- und Fußplatte notwendig; wahlweise Lenkrolle in Standard-Ausführung oder elektrostatisch entladender Ausführung	Description	Reliable and quiet swivel castor, trackless (except solid rubber electrostatically discharging), with ball bearings* and thread guard; integrated mounting plate for asymmetric fixation to aluminum profiles without overhang; compatible with all swivel and fixed castors due to consistent height level; no additional transport and base plate needed; swivel castor either in standard version or as electrostatically discharging version
Material	Gehäuse: Stahl Laufbelag: siehe Tabelle Radkörper: siehe Tabelle	Material	Housing: Steel Tread: See table Wheel body: See table
Farbe	Gehäuse: alufarbig Laufbelag: siehe Tabelle Radkörper: schwarz, grau ≈ RAL 7001	Color	Housing: Alu color Tread: See table Wheel body: Black, gray ≈ RAL 7001
Liefereinheit	1 Stück	Pack Quantity	1 piece
Extras	weitere Rollenarten, weitere Farben, weitere Oberflächen auf Anfrage	Specials	Other kinds of wheels, other colors, other surfaces on request

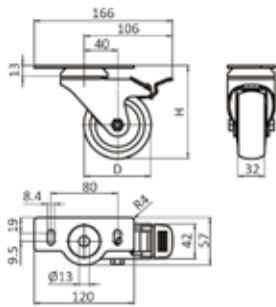

Lenkrolle Laufbelag Swivel Castor Tread	D [mm]	H [mm]	ESD	Radkörper Wheel Body	Tragkraft [N] Max. Load [N]	Gewicht [g] Weight [g]	Teil-Nr. Part #
TPE, grau ≈ RAL 7031 TPE, gray	80	111		PP, grau PP, gray	1000	710.0	098S080TD4045N
	100	136		PP, grau PP, gray	1100	787.0	098S100TD4045N
	125	161		PP, grau PP, gray	1200	873.0	098S125TD4045N
	80	111		PP, schwarz PP, black	650	740.0	098S080TD4045NESD
	100	136		PP, schwarz PP, black	700	836.0	098S100TD4045NESD
	125	161		PP, schwarz PP, black	800	937.0	098S125TD4045NESD
TPU, grau ≈ RAL 7024 TPU, gray	80	111		PA, grau PA, gray	1200	740.0	098S080UD4045N
	100	136		PA, grau PA, gray	1200	823.0	098S100UD4045N
	125	161		PA, grau PA, gray	1200	923.0	098S125UD4045N
	80	111		PA, schwarz PA, black	1000	723.0	098S080UD4045NESD
	100	136		PA, schwarz PA, black	1200	798.0	098S100UD4045NESD
	125	161		PA, schwarz PA, black	1200	886.0	098S125UD4045NESD
Vollgummi, grau ≈ RAL 7001 Solid rubber, gray	80	111		PA, schwarz PA, black	800	740.0	098S080GD4045N
	100	136		PA, schwarz PA, black	1100	885.0	098S100GD4045N
	125	161		PA, schwarz PA, black	1000	1006.0	098S125GD4045N
Vollgummi, schwarz Solid rubber, black	80	111		PA, schwarz PA, black	600	723.0	098S080GD4045NESD
	100	136		PA, schwarz PA, black	800	849.0	098S100GD4045NESD
	125	161		PA, schwarz PA, black	750	956.0	098S125GD4045NESD
PA, schwarz; *gleitgelagert PA, black; *with slide bearings	80	111		PA, schwarz PA, black	1000	648.0	098S080AD4045N
	100	136		PA, schwarz PA, black	1200	774.0	098S100AD4045N
	125	161		PA, schwarz PA, black	1200	841.0	098S125AD4045N

Bodenelemente *Floor Elements*

Lenk- & Bockrollen *Swivel and Fixed Castors*

Bockrollen *Fixed Castors*



BOCKROLLE

FIXED CASTOR

Ausführung	mit Rückenloch; für optionale Adapterplatte F	Model	With bolt hole; compatible with optional adapter plate F
Beschreibung	belastbare und laufruhige Bockrolle, spurlos (außer Vollgummi elektrostatisch entladend), kugelgelagert* mit Fadenschutz zur Befestigung an Aluminiumprofilen; kombinierbar mit allen Lenk- und Bockrollen durch gleiches Höhenniveau mit optionaler Adapterplatte F; keine zusätzliche Transport- und Fußplatte notwendig	Description	Reliable and quiet fixed castor, trackless (except solid rubber electrostatically discharging), with ball bearings* and thread guard; can be fixed to aluminum profiles; compatible with all swivel and fixed castors due to consistent height level with optional adapter plate F; no additional transport and base plate needed
Material	Gehäuse: Stahl Laufbelag: siehe Tabelle Radkörper: siehe Tabelle	Material	Housing: Steel Tread: See table Wheel body: See table
Farbe	Gehäuse: alufarbig Laufbelag: siehe Tabelle Radkörper: schwarz, grau ≈ RAL 7001	Color	Housing: Alu color Tread: See table Wheel body: Black, gray ≈ RAL 7001
Liefereinheit	1 Stück	Pack Quantity	1 piece
Extras	weitere Rollenarten, weitere Farben, weitere Oberflächen auf Anfrage	Specials	Other kinds of wheels, other colors, other surfaces on request

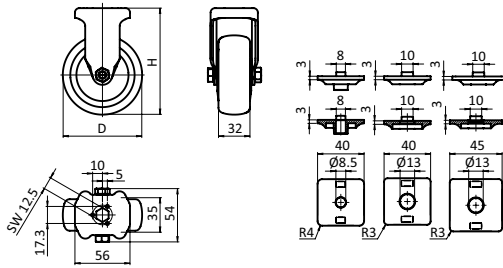

Bockrolle Laufbelag <i>Fixed Castor Tread</i>	D [mm]	H [mm]	ESD	Radkörper <i>Wheel Body</i>	Tragkraft [N] <i>Max. Load [N]</i>	Gewicht [g] <i>Weight [g]</i>	Teil-Nr. <i>Part #</i>
TPE, grau ≈ RAL 7031 <i>TPE, gray</i>	80	108		PP, grau <i>PP, gray</i>	1000	323.0	098F080TN
	100	133		PP, grau <i>PP, gray</i>	1100	390.0	098F100TN
	125	158		PP, grau <i>PP, gray</i>	1200	472.0	098F125TN
	80	108		PP, schwarz <i>PP, black</i>	650	353.0	098F080TNESD
	100	133		PP, schwarz <i>PP, black</i>	700	439.0	098F100TNESD
	125	158		PP, schwarz <i>PP, black</i>	800	536.0	098F125TNESD
TPU, grau ≈ RAL 7024 <i>TPU, gray</i>	80	108		PA, grau <i>PA, gray</i>	1200	353.0	098F080UN
	100	133		PA, grau <i>PA, gray</i>	1200	426.0	098F100UN
	125	158		PA, grau <i>PA, gray</i>	1200	522.0	098F125UN
	80	108		PA, schwarz <i>PA, black</i>	1000	336.0	098F080UNESD
	100	133		PA, schwarz <i>PA, black</i>	1200	401.0	098F100UNESD
	125	158		PA, schwarz <i>PA, black</i>	1200	485.0	098F125UNESD
Vollgummi, grau ≈ RAL 7001 <i>Solid rubber, gray</i>	80	108		PA, schwarz <i>PA, black</i>	800	353.0	098F080GN
	100	133		PA, schwarz <i>PA, black</i>	1100	488.0	098F100GN
	125	158		PA, schwarz <i>PA, black</i>	1000	605.0	098F125GN
Vollgummi, schwarz <i>Solid rubber, black</i>	80	108		PA, schwarz <i>PA, black</i>	600	336.0	098F080GNESD
	100	133		PA, schwarz <i>PA, black</i>	800	452.0	098F100GNESD
	125	158		PA, schwarz <i>PA, black</i>	750	555.0	098F125GNESD
PA, schwarz; *gleitgelagert <i>PA, black; *with slide bearings</i>	80	108		PA, schwarz <i>PA, black</i>	1000	261.0	* 098F080AN
	100	133		PA, schwarz <i>PA, black</i>	1200	377.0	098F100AN
	125	158		PA, schwarz <i>PA, black</i>	1200	440.0	098F125AN



BOCKROLLE MIT ANSCHRAUBPLATTE 38 - 1,5" / 40 / 45 FIXED CASTOR WITH MOUNTING PLATE

Ausführung	mit Rückenlochung	Model	With bolt hole pattern
Beschreibung	belastbare und laufruhige Bockrolle, spurlos (außer Vollgummi elektrostatisch entladend), kugelgelagert* mit Fadenschutz und integrierter Anschraubplatte zur asymmetrischen Befestigung an Aluminiumprofilen 38 - 1,5", 40 mm und 45 mm ohne Überstand; kombinierbar mit allen Lenk- und Bockrollen durch gleiches Höhenniveau; keine zusätzliche Transport- und Fußplatte notwendig	Description	Reliable and quiet fixed castor, trackless (except solid rubber electrostatically discharging), with ball bearings* and thread guard; integrated mounting plate for asymmetric fixation to aluminum profiles 38 - 1.5", 40 mm and 45 mm without overhang; compatible with all swivel and fixed castors due to consistent height level; no additional transport and base plate needed
Material	Gehäuse: Stahl Laufbelag: siehe Tabelle Radkörper: siehe Tabelle	Material	Housing: Steel Tread: See table Wheel body: See table
Farbe	Gehäuse: alufarbig Laufbelag: siehe Tabelle Radkörper: schwarz, grau ≈ RAL 7001	Color	Housing: Alu color Tread: See table Wheel body: Black, gray ≈ RAL 7001
Liefereinheit	1 Stück	Pack Quantity	1 piece
Extras	weitere Rollenarten, weitere Farben, weitere Oberflächen auf Anfrage	Specials	Other kinds of wheels, other colors, other surfaces on request

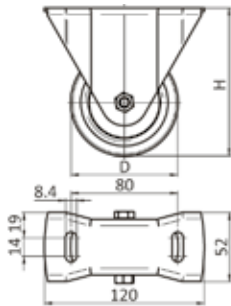

Bockrolle Laufbelag Fixed Castor Tread	D [mm]	H [mm]	ESD	Radkörper Wheel Body	Tragkraft [N] Max. Load [N]	Gewicht [g] Weight [g]	Teil-Nr. Part #
TPE, grau ≈ RAL 7031 TPE, gray	80	111		PP, grau PP, gray	1000	484.0	098F080T4045N
	100	136		PP, grau PP, gray	1100	577.0	098F100T4045N
	125	161		PP, grau PP, gray	1200	675.0	098F125T4045N
	80	111		PP, schwarz PP, black	650	514.0	098F080T4045NESD
	100	136		PP, schwarz PP, black	700	626.0	098F100T4045NESD
	125	161		PP, schwarz PP, black	800	739.0	098F125T4045NESD
TPU, grau ≈ RAL 7024 TPU, gray	80	111		PA, grau PA, gray	1200	514.0	098F080U4045N
	100	136		PA, grau PA, gray	1200	613.0	098F100U4045N
	125	161		PA, grau PA, gray	1200	725.0	098F125U4045N
	80	111		PA, schwarz PA, black	1000	497.0	098F080U4045NESD
	100	136		PA, schwarz PA, black	1200	588.0	098F100U4045NESD
	125	161		PA, schwarz PA, black	1200	758.0	098F125U4045NESD
Vollgummi, grau ≈ RAL 7001 Solid rubber, gray	80	111		PA, schwarz PA, black	800	514.0	098F080G4045N
	100	136		PA, schwarz PA, black	1100	675.0	098F100G4045N
	125	161		PA, schwarz PA, black	1000	725.0	098F125G4045N
Vollgummi, schwarz Solid rubber, black	80	111		PA, schwarz PA, black	600	497.0	098F080G4045NESD
	100	136		PA, schwarz PA, black	800	639.0	098F100G4045NESD
	125	161		PA, schwarz PA, black	750	758.0	098F125G4045NESD
PA, schwarz; *gleitgelagert PA, black; *with slide bearings	80	111		PA, schwarz PA, black	1000	422.0	098F080A4045N
	100	136		PA, schwarz PA, black	1200	564.0	098F100A4045N
	125	161		PA, schwarz PA, black	1200	643.0	098F125A4045N

SET HUBROLLE HYDRAULISCH

SET HYDRAULIC LIFT CASTOR

Ausführung	Aluminiumdruckguss	Model	Aluminum die-cast
Beschreibung	Hubsystem für schnelles und flexibles Platzieren von Anlagen oder Montagetischen etc.; Übersetzungsverhältnis Kolben / Hubeinheit 10:1	Description	Lift castor system for a fast and flexible placing of plants or assembling tables etc.; gear transmission ratio: 10:1
Material	Gehäuse: Aluminiumdruckguss, teflonelagert Rolle: Kunststoff PA, kugelgelagert Rollengehäuse: Stahl verzinkt	Material	Housing: Aluminum die-cast with PTFE bearing Roller: Plastic PA with ball bearing Roller housing: Steel, zinc plated
Set	4 Hubeinheiten 1 hydraulische Antriebseinheit 4 Hydraulikschläuche á 3 m, vorbefüllt	Set	4 lifting units 1 hydraulic drive unit 4 hydraulic pipes at each 3 m, pre-filled
Extras	weitere Sets auf Anfrage	Specials	Other sets on request
Hinweis	*zentriert platziert	Tip	*positioned centered



Set Hubrolle hydraulisch Set Hydraulic Lift Castor	Tragkraft [kg] Max. Load [kg]	Tragkraft pro Hubeinheit [kg] Max. Load per lifting unit [kg]	Gewicht [kg] Weight [kg]	Teil-Nr. Part #
	*2000.0	500.0	30.8	06001HR2000

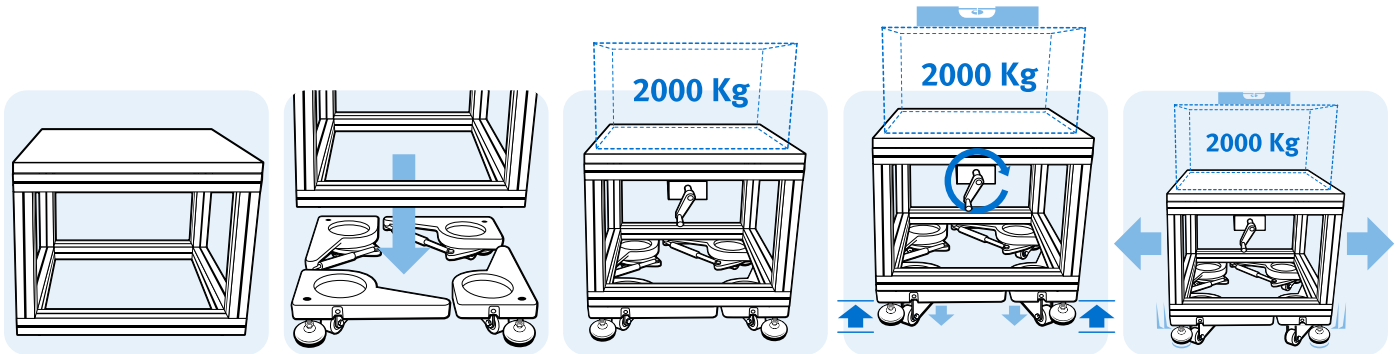

HUBROLLE ELEKTRISCH

ELECTRIC LIFT CASTOR

<p>Ausführung Aluminiumdruckguss</p> <p>Beschreibung Hubsystem für schnelles und flexibles Platzieren von Anlagen oder Montagetischen etc.; mit elektrischem Antrieb - 24 V, elektrischer Anschlussstecker Wieland RST20i2</p> <p>Material Gehäuse: Aluminiumdruckguss, teflongelagert Rolle: Kunststoff PA, kugellagert Rollengehäuse: Stahl verzinkt</p> <p>Set 4 Hubeinheiten inkl. elektrischer Antriebseinheit</p> <p>Hinweis *zentriert platziert</p>	<p>Model Aluminum die-cast</p> <p>Description Lift castor system for a fast and flexible placing of plants or assembling tables etc.; with electrical drive - 24 V, electrical connection plug Wieland RST20i2</p> <p>Material Housing: Aluminum die-cast with PTFE bearing Roller: Plastic PA with ball bearing Roller housing: Steel, zinc plated</p> <p>Set 4 lifting units with electrical drives</p> <p>Tip *positioned centered</p>
--	--

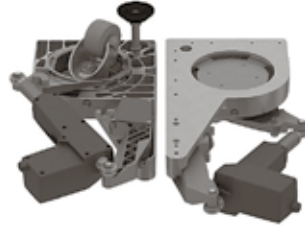
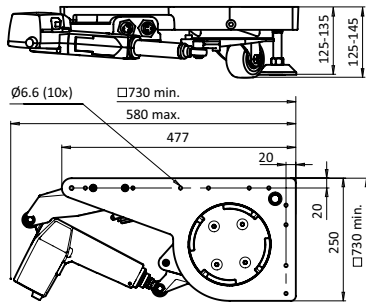

Hubrolle elektrisch <i>Electric Lift Castor</i>	Tragkraft [kg] <i>Max. Load [kg]</i>	Tragkraft pro Hubeinheit [kg] <i>Max. Load per lifting unit [kg]</i>	Gewicht [kg] <i>Weight [kg]</i>	Teil-Nr. <i>Part #</i>
	500.0	500.0	9.2	06001HR500E
Set	*2000.0	500.0	36.8	06001HR500E24

INHALTSÜBERSICHT *CONTENT OVERVIEW*

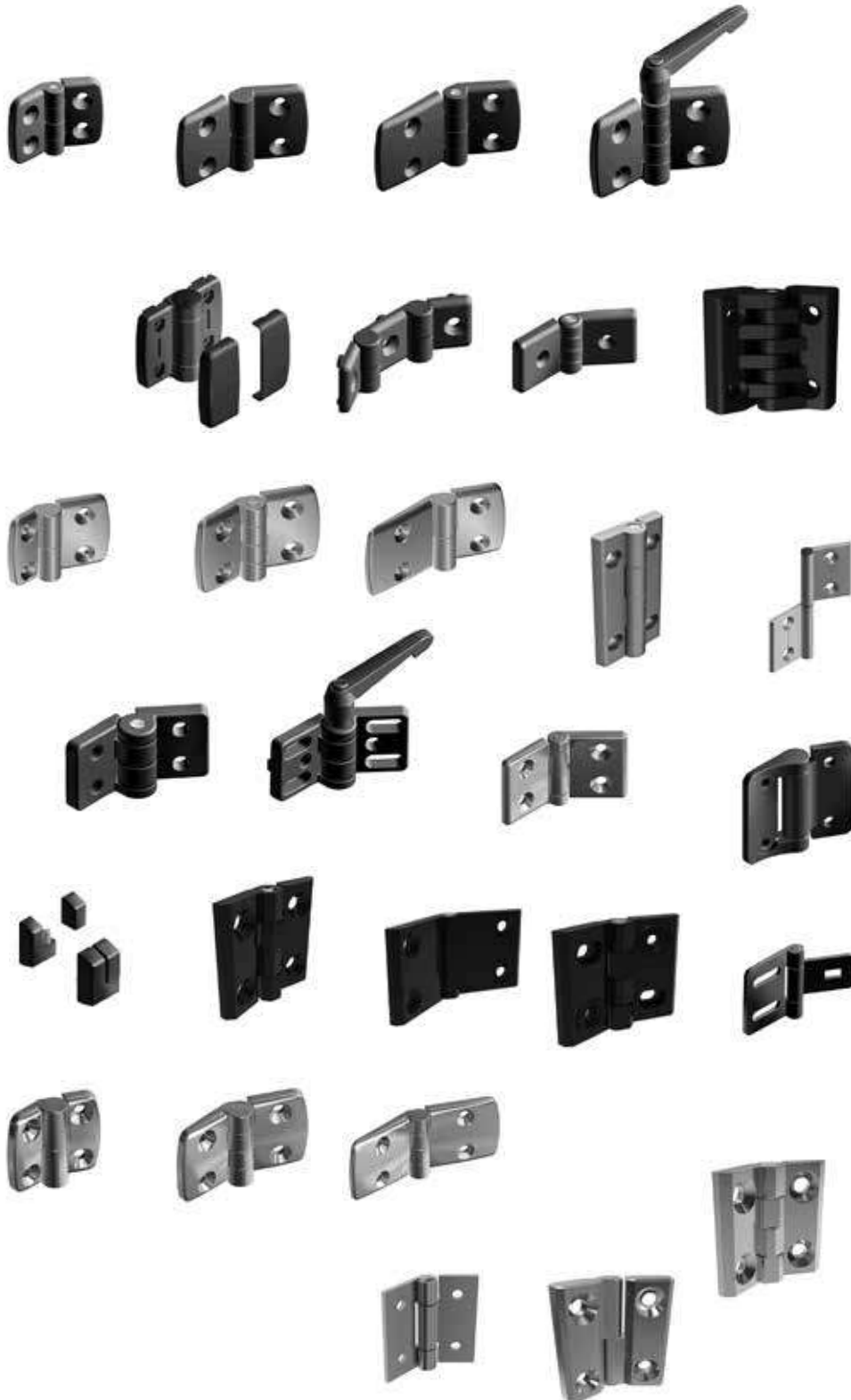







































Bodenelemente <i>Floor Elements</i>	1
Scharniere <i>Hinges</i>	2
Nutmuttern und -schrauben <i>T-Nuts and T-Bolts</i>	3
Verbindungstechnik <i>Connecting Systems</i>	4
Griffe und Verschlüsse <i>Handles and Latches</i>	5
Arbeitsplatzkomponenten <i>Components for Work Stations</i>	6
Gleiter und Rollen <i>Sliders and Rollers</i>	7
Fördertechnik <i>Conveyors</i>	8
Schutz- und Trennwandelemente <i>Enclosures, Guards, Partitions</i>	9
Flächenbefestigungen <i>Panel Fasteners</i>	10
Abdeckelemente <i>Cover Elements</i>	11
Kabelführungen <i>Cable Management</i>	12
Diverse Komponenten <i>Miscellaneous Components</i>	13
Rundrohrkomponenten <i>Tubular Frame Components</i>	14

Scharniere Hinges

Inhaltsverzeichnis Table of Content



	Kunststoff-Kombischarnier 20	Plastic Combi Hinge 20	138		Systemscharnier 30 mit Rast-Funktion	System Hinge 30 with Positioning Function	157
	Kunststoff-Kombischarnier 20	Plastic Combi Hinge 20	139		Systemscharnier 40 mit Rast-Funktion	System Hinge 40 with Positioning Function	158
	Kunststoff-Kombischarnier 25	Plastic Combi Hinge 25	140		Systemscharnier 30 mit einstellbarer Friktion	System Hinge 30 with Adjustable Friction	159
	Kunststoff-Kombischarnier 25	Plastic Combi Hinge 25	141		Systemscharnier 40 mit einstellbarer Friktion	System Hinge 40 with Adjustable Friction	160
	Kunststoff-Kombischarnier 30	Plastic Combi Hinge 30	142		Kunststoffscharnier 20 Mini	Plastic Hinge 20 Mini	161
	Kunststoff-Kombischarnier 30	Plastic Combi Hinge 30	143		Kunststoffscharnier leicht 35	Light Plastic Hinge 35	162
	Kunststoff-Kombischarnier 35	Plastic Combi Hinge 35	144		Kunststoffscharnier 32 x 60	Plastic Hinge 32 x 60	163
	Kunststoff-Kombischarnier 35	Plastic Combi Hinge 35	145		Kunststoffscharnier, doppelt	Plastic Hinge, Double	164
	Kunststoff-Kombischarnier 40	Plastic Combi Hinge 40	146		Kunststoffscharnier schwer 30	Heavy-duty Plastic Hinge 30	165
	Kunststoff-Kombischarnier 40	Plastic Combi Hinge 40	147		Kunststoffscharnier schwer 40	Heavy-duty Plastic Hinge 40	166
	Kunststoff-Kombischarnier 45	Plastic Combi Hinge 45	148		Kunststoffscharnier schwer 45	Heavy-duty Plastic Hinge 45	167
	Kunststoff-Kombischarnier 45	Plastic Combi Hinge 45	149		Kunststoffscharnier schwer 60	Heavy-duty Plastic Hinge 60	168
	Kunststoff-Kombischarnier 50	Plastic Combi Hinge 50	150		Kunststoffscharnier schwer 65 x 64	Heavy-duty Plastic Hinge 65 x 64	169
	Kunststoff-Kombischarnier 50	Plastic Combi Hinge 50	151		Aludruckguss-Kombischarnier 25	Aluminum Die-cast Combi Hinge 25	170
	Kunststoff-Kombischarnier 60	Plastic Combi Hinge 60	152		Aludruckguss-Kombischarnier 25	Aluminum Die-cast Combi Hinge 25	171
	Kunststoff-Kombischarnier 60	Plastic Combi Hinge 60	153		Aludruckguss-Kombischarnier 30	Aluminum Die-cast Combi Hinge 30	172
	Kombischarnier mit Klemmhebel	Combi Hinge with Locking Lever	154		Aludruckguss-Kombischarnier 30	Aluminum Die-cast Combi Hinge 30	173
	Systemscharnier 30	System Hinge 30	155		Aludruckguss-Kombischarnier 35	Aluminum Die-cast Combi Hinge 35	174
	Systemscharnier 40	System Hinge 40	156		Aludruckguss-Kombischarnier 35	Aluminum Die-cast Combi Hinge 35	175

Scharniere Hinges

Inhaltsverzeichnis Table of Content



















	Aludruckguss-Kombischarnier 40	Aluminum Die-cast Combi Hinge 40	176		Minischarnier	Mini Hinge	195
	Aludruckguss-Kombischarnier 40	Aluminum Die-cast Combi Hinge 40	177		Metallscharnier 40 x 40	Metal Hinge 40 x 40	196
	Aludruckguss-Kombischarnier 45	Aluminum Die-cast Combi Hinge 45	178		Metallscharnier 50 x 50	Metal Hinge 50 x 50	197
	Aludruckguss-Kombischarnier 45	Aluminum Die-cast Combi Hinge 45	179		Metallscharnier 50 x 63	Metal Hinge 50 x 63	198
	Aludruckguss-Kombischarnier 50	Aluminum Die-cast Combi Hinge 50	180		Metallscharnier 50 x 76	Metal Hinge 50 x 76	199
	Aludruckguss-Kombischarnier 50	Aluminum Die-cast Combi Hinge 50	181		Metallscharnier 60 x 60	Metal Hinge 60 x 60	200
	Aludruckguss-Kombischarnier 60	Aluminum Die-cast Combi Hinge 60	182		Metallscharnier 60 x 74	Metal Hinge 60 x 74	201
	Aludruckguss-Kombischarnier 60	Aluminum Die-cast Combi Hinge 60	183		Metallscharnier 60 x 76	Metal Hinge 60 x 76	202
	Aludruckguss-Scharnier	Aluminum die-cast Hinge	184		Metallscharnier 60 x 90	Metal Hinge 60 x 90	203
	Schwerlastscharnier	Heavy-duty Hinge	185		Metallscharnier 60 x 120	Metal Hinge 60 x 120	204
	Set Alu-Scharnier, schwer	Set Heavy Aluminum Hinge	186		2D-Scharnier, justierbar in zwei Achsen	2D Hinge, adjustable in two directions	205
	Aluminium-Scharnier 40 leicht	Aluminum Hinge 40 Light	187		2D-Scharnier, justierbar nur in der Höhe	2D Hinge, only adjustable vertically	206
	Innenliegendes Scharnier-Element	Concealed Hinge Component	188		2D-Scharnier, justierbar nur in der Breite	2D Hinge, only adjustable horizontally	207
	Außenliegendes Scharnier-Element	External Hinge Component	189		Metallscharnier 40 x 38 mit konstanter Friktion	Metal Hinge 40 x 38 with Constant Friction	208
	Zinkdruckguss-Kombischarnier 40 und 45	Zinc Die-cast Combi Hinge 40 and 45	190		Metallscharnier 58 x 51 mit konstanter Friktion	Metal Hinge 58 x 51 with Constant Friction	209
	Kombischarnier mit Klemmhebel	Combi Hinge with Locking Lever	191		Rastscharnier	Positioning Hinge	210
	Zinkdruckguss-Scharnier 30 mit Langlöchern	Zinc die-cast Hinge 30 with Oblong Holes	192		Metallscharnier leicht	Light Metal Hinge	211
	Zinkdruckguss-Scharnier 40 mit Langlöchern	Zinc die-cast Hinge 40 with Oblong Holes	193		Edelstahl-Kombischarnier 20	Stainless Steel Combi Hinge 20	212
	Zinkdruckguss-Scharnier mit Klemmhebel	Zinc die-cast Hinge with Locking Lever	194		Edelstahl-Kombischarnier 25	Stainless Steel Combi Hinge 25	213

Scharniere Hinges

Inhaltsverzeichnis *Table of Content*



	Edelstahl-Kombischarnier 25	<i>Stainless Steel Combi Hinge 25</i>	214
	Edelstahl-Kombischarnier 30	<i>Stainless Steel Combi Hinge 30</i>	215
	Edelstahl-Kombischarnier 30	<i>Stainless Steel Combi Hinge 30</i>	216
	Edelstahl-Kombischarnier 40	<i>Stainless Steel Combi Hinge 40</i>	217
	Edelstahl-Kombischarnier 40	<i>Stainless Steel Combi Hinge 40</i>	218
	Edelstahl-Kombischarnier 45	<i>Stainless Steel Combi Hinge 45</i>	219
	Edelstahl-Kombischarnier 45	<i>Stainless Steel Combi Hinge 45</i>	220
	Edelstahl-Kombischarnier 60	<i>Stainless Steel Combi Hinge 60</i>	221
	Edelstahl-Kombischarnier 60	<i>Stainless Steel Combi Hinge 60</i>	222
	Edelstahlscharnier leicht	<i>Light Stainless Steel Hinge</i>	223
	Edelstahlscharnier 40 x 40	<i>Stainless Steel Hinge 40 x 40</i>	224
	Edelstahlscharnier 50 x 50	<i>Stainless Steel Hinge 50 x 50</i>	225
	Edelstahlscharnier 50 x 63	<i>Stainless Steel Hinge 50 x 63</i>	226
	Edelstahlscharnier 50 x 76	<i>Stainless Steel Hinge 50 x 76</i>	227
	Edelstahlscharnier 60 x 60	<i>Stainless Steel Hinge 60 x 60</i>	228
	Edelstahlscharnier LR	<i>Stainless Steel Hinge LR</i>	229

SCHARNIERE

Linkes und rechtes Scharnier

Für jedes aushängbare Scharnier gibt es eine linke und eine rechte Version. Geben Sie bitte bei der Bestellung an, auf welcher Seite die Tür oder Klappe angeschlagen wird.

HINGES

Left and right hinges

Every hinge has a left and a right version. When ordering, please indicate which way you want the door or flap to open.

Linkes Scharnier

Das feste Lager ist links, die Klappe oder Tür öffnet von rechts nach links.

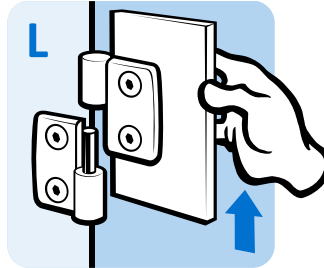

Left hinge

The wing with the fixed axle is on the left side, opening the door/flap from the right to the left.

Rechtes Scharnier

Das feste Lager ist rechts, die Klappe oder Tür öffnet von links nach rechts.

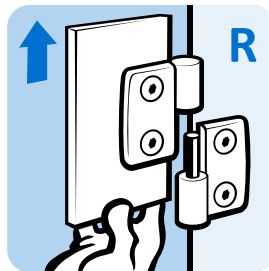

Right hinge

The wing with the fixed axle is on the right side, opening the door/flap from the left to the right.

Festes Scharnier

Das Scharnier kann nicht ausgehängt werden. Es eignet sich für den Einsatz links und rechts.

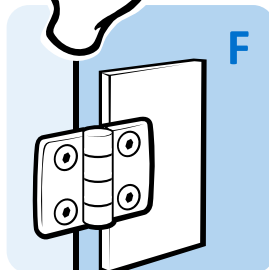

Fixed hinge

The fixed hinge cannot be taken apart and can be used for left or right hand opening.

Ein kleiner Trick

Eigentlich ganz einfach: wenn Sie eine Klappe oder Tür nicht aushängbar befestigen wollen, können Sie dafür auch ein linkes und ein rechtes aushängbares Scharnier verwenden. Die beiden Scharniere werden im eingehängten Zustand montiert und sichern sich gegenseitig.

A little trick

It is actually quite simple: when you want a door or flap to be non-detachable, you can also use detachable hinges. Just take a right and a left one and because of their opposite positions the door/flap cannot be lifted off

Tür aushängbar

Verwenden Sie entweder zwei rechte oder zwei linke Scharniere.

Detachable door / flap

Use either two right or two left hinges.

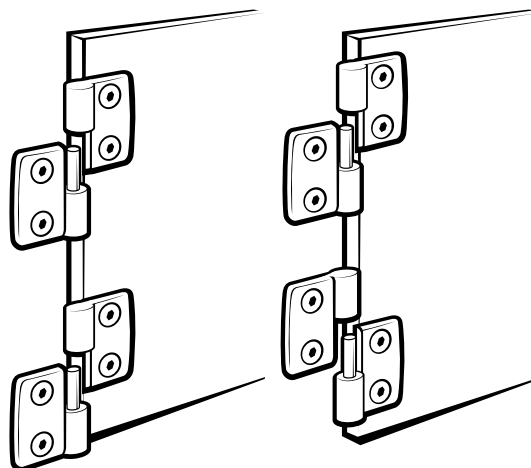

Tür nicht aushängbar

Verwenden Sie je ein linkes und ein rechtes Scharnier.

Non-detachable door / flap

Use a left and a right hinge.

SCHARNIERE

Führungsnasen für Aluminiumprofile

Viele unserer Scharniere können Sie auch mit Führungsnasen für die Nuten von Aluminiumprofilen haben. Sie sichern das Scharnier gegen Verdrehen und machen es belastbarer. Wir haben alle unsere Scharniere so gestaltet, dass Sie diese Führungsnasen mit einem Schraubendreher einfach herausbrechen können. Wenn Sie das Scharnier also anders einsetzen wollen als ursprünglich geplant: kein Problem.

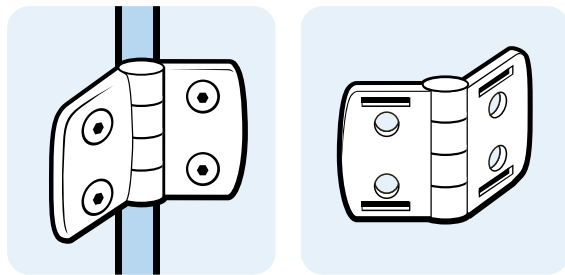

Flächenelemente

Verwenden Sie das Scharnier ohne Führungsnasen, wie hier im Katalog dargestellt.

Flat surfaces

Use the hinge without fixing pins, as pictured here.

Maßtoleranzen

Folgende Maßtoleranzen gelten für die in diesem Katalog gezeigten Produkte als Standard. Sprechen Sie mit uns, wenn Sie in besonderen Fällen engere Toleranzen benötigen.

A1 = ± 0,5 mm
A2 = ± 0,5 mm

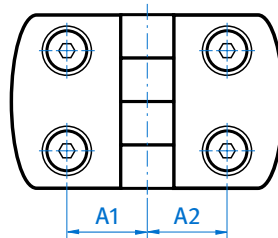

A1 = ± 0,5 mm
A2 = ± 0,5 mm

Belastungsprüfungen

Ermittlung der maximalen Kraft [N] bis zu einer Höhe, bei der Teile des Scharniers brechen.

Load Bearing Tests

Indication of the maximum force [N] to the point when parts of the hinge break.

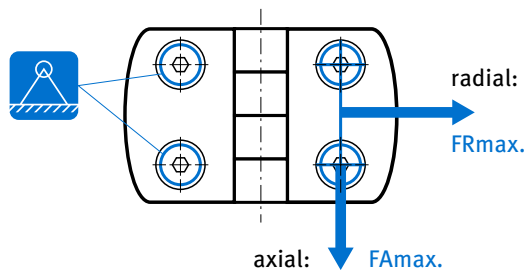

Alle Angaben dienen Ihrer Information und stellen keine rechtsverbindliche Zusicherung von Eigenschaften dar.

All information is just for reference and does not pose a legally binding agreement about the product properties.

HINGES

Guiding pins for aluminum Profiles

Many of our hinges can be supplied with fixing pins for the slots of aluminum profiles. They prevent the hinge from rotating and increase its load bearing.

We have designed and produced the hinges in such a way that these fixing pins can be easily broken off with a screw driver, so in case you wish to use the hinge in another way than initially intended, this is not a problem.

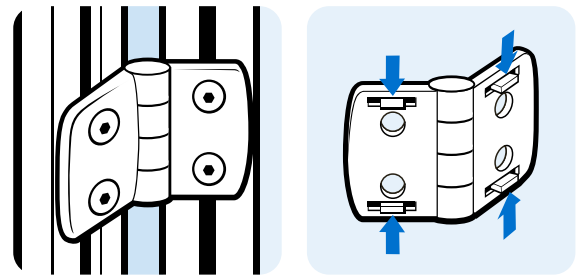

Aluminiumprofile

Verwenden Sie das Scharnier mit Führungsnasen, passend zur Nutbreite Ihres Profiles.

Aluminum profiles

Use the hinge with the fixing pins that fit the slot of your profile.

Dimensional Tolerances

The following dimensional tolerances are valid for the indications in this catalog. Please contact us if you need lower tolerances in special cases.

KOMBISCHARNIERE

- frei kombinierbare Flügelmaße von 25 bis 60
- flexibler Einsatz durch optionale Nutführungen
- drei Materialien / Oberflächen für verschiedene Einsatzgebiete
- elegantes FATH-Design und hochwertige Edelstahlachse

Die FATH-Kombischarniere aus Kunststoff, Edelstahl und Aludruckguss bilden eine optisch einheitliche Familie, innerhalb derer Sie die Flügelängen 25, 30, 35, 40, 45, 50 und 60, je nach Anwendungsfall, frei miteinander kombinieren können.

So ergeben sich über 350 Kombinationen, die wir auf den folgenden Seiten übersichtlich dargestellt haben. Zur Montage auf Aluprofilen stellen wir die Scharniere auf Wunsch rückseitig mit Nutführungen aus – je nach Material sind diese angespritzt (Kunststoff PA) oder zum Einstecken in die vorhandenen Aufnahmen (Aluminium-Druckguss).

Kombischarniere aus Kunststoff PA

Die Scharnierflügel aus glasfaserverstärktem Polyamid in schwarz mit strukturierter Oberfläche stellen die preisgünstige und robuste Basislösung dar. Optional gibt es die Scharnierflügel mit rückseitig angespritzten Nutnasen als Justierhilfe bei der Montage in Nutprofilen. Diese Nutnasen lassen sich mit einer Zange, einem Cutter oder einer Feile entfernen.



Plastic Combi Hinges PA

These hinge leaves are made of glass fiber reinforced polyamide in black with a textured finish. They represent a cost-effective and sturdy basic solution. As an option, for assembly on aluminum profiles with T-slots, we supply our PA hinge leaves with integrated guiding pins. These can be removed with pliers, a cutter or with a file.

Kombischarniere aus Aluminiumdruckguss

Die matt alufarbige Oberfläche dieser Scharniere aus Aluminiumdruckguss passt besonders gut zu eloxierten Aluminiumprofilen. Alle Scharnierflügel aus Aluminiumdruckguss verfügen rückseitig über Aufnahmen für Zentrierbolzen.



Die-cast Aluminum Combi Hinges

Providing a matt alu color surface, these hinges particularly fit with anodized aluminum profiles. All aluminum die-cast hinge leaves have supports for optional centering bolts.

Kombischarniere aus Edelstahl V4

Die Edelstahlscharniere von FATH sehen mit ihrer glanzpolierten Oberfläche nicht nur fantastisch aus, sie sind auch besonders beständig gegenüber Umwelteinflüssen. Die Bohrungen für die Scharnierachsen werden in einem speziellen Verfahren nach der Montage verschlossen. Die Edelstahlscharniere sind rückseitig plan.



Stainless Steel Combi Hinges

FATH stainless steel combi hinges not only look gorgeous due to their polished surface, they are also exceptionally resistant to environmental factors. After assembly of the axles in the bore holes, we close the end faces of the hinge using a special process. Stainless steel hinges are flat on the rear side.



Übrigens: Kombischarniere werden, wie die meisten anderen FATH-Scharniere, mit Edelstahlachse geliefert.

Note: Combi hinges, as well as most of the other FATH hinges, are supplied with a stainless steel axle as standard.



Der Spaltabstand (G) der Kombischarniere 25 bis 60 beträgt 5 mm, bei den Kombischarnieren MINI 20 beträgt der Spaltabstand nur 3 mm.

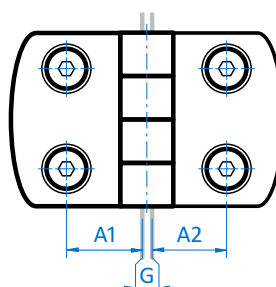

The gap clearance (G) of the combi hinges 25 to 60 is 5 mm, combi hinges MINI 20 have a 3 mm gap clearance.

Die Montage der Kombischarniere erfolgt mit selbstzentrierenden Senkkopfschrauben.

Combi hinges are made for mounting with self-centering countersunk screws.

Scharniere Hinges

Kunststoffscharniere Plastic Hinges

Kombischarniere Combi Hinges



KUNSTSTOFF-KOMBISCHARNIER 20

PLASTIC COMBI HINGE 20

Ausführung	aushängbar	Model	Detachable
Beschreibung	für Flächenelemente und Aluminiumprofile	Description	To hinge panels or aluminum profiles
Material	Flügel: Kunststoff PA, glasfaserverstärkt Achse: Edelstahl	Material	Wings: Plastic PA, glass fiber reinforced Axle: Stainless steel
Farbe	schwarz	Color	Black
Befestigung	vorderseitig mit Senkschrauben M4	Fastening	From the front, using M4 countersunk screws
Liefereinheit	10 Stück	Pack Quantity	10 pieces
Extras	☁ elektrostatisch entladend, weitere Farben, Führungsnasen zur Montage auf Aluminiumprofilen auf Anfrage	Specials	☁ electrostatically discharging, further colors, fixing pins for installation on aluminum profiles available on request

2

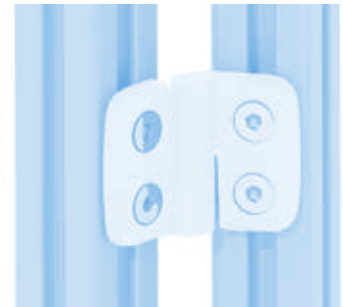
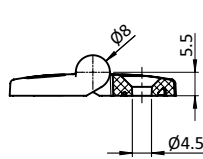
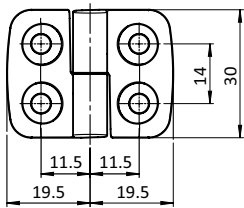

Kombischarnier Combi Hinge	F _{Amax} [N]	F _{Rmax} [N]	Bezeichnung Description	Gewicht [g] Weight [g]	Teil-Nr. Part #
L: links Left	50	100	20 / 20	6.0	095K2020L00
R: rechts Right	50	100	20 / 20	6.0	095K2020R00

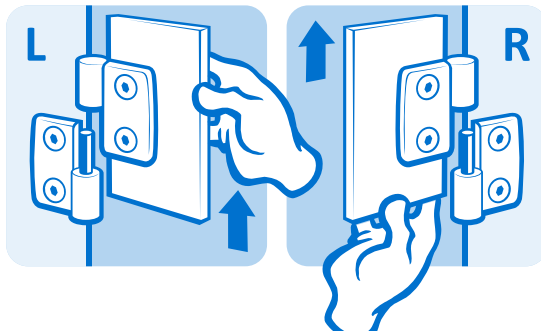

Scharniere Hinges

Kunststoffscharniere Plastic Hinges

Kombischarniere Combi Hinges



KUNSTSTOFF-KOMBISCHARNIER 20

PLASTIC COMBI HINGE 20

Ausführung	nicht aushängbar	Model	Non-detachable
Beschreibung	für Flächenelemente und Aluminiumprofile	Description	To hinge panels or aluminum profiles
Material	Flügel: Kunststoff PA, glasfaserverstärkt Achse: Edelstahl	Material	Wings: Plastic PA, glass fiber reinforced Axle: Stainless steel
Farbe	schwarz	Color	Black
Befestigung	vorderseitig mit Senkschrauben M4	Fastening	From the front, using M4 countersunk screws
Liefereinheit	10 Stück	Pack Quantity	10 pieces
Extras	☁ elektrostatisch entladend, weitere Farben, Führungsnasen zur Montage auf Aluminiumprofilen auf Anfrage	Specials	☁ electrostatically discharging, further colors, fixing pins for installation on aluminum profiles available on request

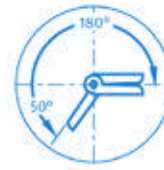
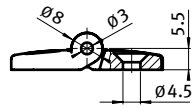
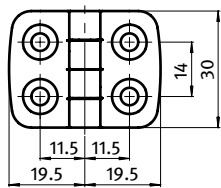

Kombischarnier Combi Hinge	F _{Amax} [N]	F _{Rmax} [N]	Bezeichnung Description	Gewicht [g] Weight [g]	Teil-Nr. Part #
nicht aushängbar Non-detachable	200	400	20 / 20	7.5	095012

2

Scharniere Hinges

Kunststoffscharniere Plastic Hinges

Kombischarniere Combi Hinges

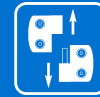

KUNSTSTOFF-KOMBISCHARNIER 25

PLASTIC COMBI HINGE 25

Ausführung	aushängbar	Model	Detachable
Beschreibung	für Flächenelemente und Aluminiumprofile	Description	To hinge panels or aluminum profiles
Material	Flügel: Kunststoff PA, glasfaserverstärkt Achse: Edelstahl	Material	Wings: Plastic PA, glass fiber reinforced Axle: Stainless steel
Befestigung	vorderseitig mit Senkschrauben M6	Fastening	From the front, using M6 countersunk screws
Liefereinheit	10 Stück	Pack Quantity	10 pieces
Extras	⚡ elektrostatisch entladend, weitere Farben, Führungsnasen zur Montage auf Aluminiumprofilen auf Anfrage	Specials	⚡ electrostatically discharging, further colors, fixing pins for installation on aluminum profiles available on request

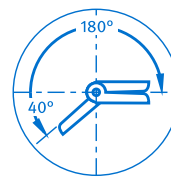
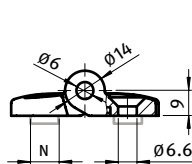
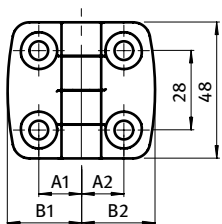

Kombischarnier Combi Hinge	A1 [mm]	A2 [mm]	B1 [mm]	B2 [mm]	F _{Amax} [N]	F _{Rmax} [N]	N	Bezeichnung Description	Gewicht [g] Weight [g]	Teil-Nr. Part #
L: links Left	15.0	15.0	26.0	26.0	425	625		25/25	31.0	095K2525L00
	15.0	15.0	26.0	26.0	425	625	6	25/25	31.0	095K2525L06
	15.0	15.0	26.0	26.0	425	625	8	25/25	31.0	095K2525L08
	15.0	17.5	26.0	29.5	500	700		25/30	33.0	095K2530L00
	15.0	20.0	26.0	36.0	400	700		25/35	35.0	095K2535L00
	15.0	22.5	26.0	38.5	350	800		25/40	37.0	095K2540L00
	15.0	25.0	26.0	43.5	325	800		25/45	38.0	095K2545L00
	15.0	27.5	26.0	48.5	320	800		25/50	40.0	095K2550L00
	15.0	32.5	26.0	57.5	240	800		25/60	43.0	095K2560L00
R: rechts Right	15.0	15.0	26.0	26.0	425	625		25/25	31.0	095K2525R00
	15.0	15.0	26.0	26.0	425	625	6	25/25	31.0	095K2525R06
	15.0	15.0	26.0	26.0	425	625	8	25/25	31.0	095K2525R08
	17.5	15.0	29.5	26.0	500	700		25/30	33.0	095K2530R00
	20.0	15.0	36.0	26.0	400	700		25/35	35.0	095K2535R00
	22.5	15.0	38.5	26.0	350	800		25/40	37.0	095K2540R00
	25.0	15.0	43.5	26.0	325	800		25/45	38.0	095K2545R00
	27.5	15.0	48.5	26.0	320	800		25/50	40.0	095K2550R00
	32.5	15.0	57.5	26.0	240	800		25/60	43.0	095K2560R00

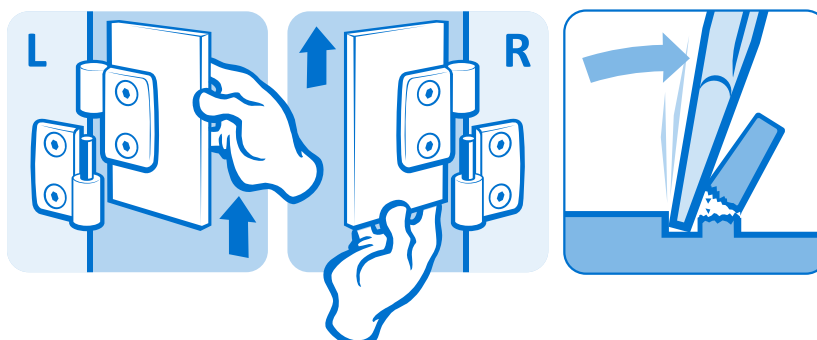

Scharniere Hinges

Kunststoffscharniere Plastic Hinges

Kombischarniere Combi Hinges



KUNSTSTOFF-KOMBISCHARNIER 25

PLASTIC COMBI HINGE 25

Ausführung	nicht aushängbar	Model	Non-detachable
Beschreibung	für Flächenelemente und Aluminiumprofile	Description	To hinge panels or aluminum profiles
Material	Flügel: Kunststoff PA, glasfaserverstärkt Achse: Edelstahl	Material	Wings: Plastic PA, glass fiber reinforced Axle: Stainless steel
Farbe	schwarz	Color	Black
Befestigung	vorderseitig mit Senkschrauben M6	Fastening	From the front, using M6 countersunk screws
Liefereinheit	10 Stück	Pack Quantity	10 pieces
Extras	☁ elektrostatisch entladend, weitere Farben, Führungsnasen zur Montage auf Aluminiumprofilen auf Anfrage	Specials	☁ electrostatically discharging, further colors, fixing pins for installation on aluminum profiles available on request

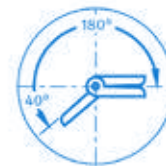
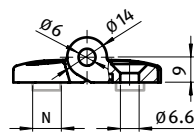
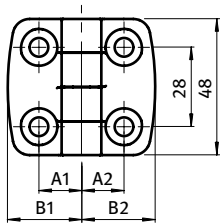

Scharnier Hinge	A1 [mm]	A2 [mm]	B1 [mm]	B2 [mm]	F _{Amax} [N]	F _{Rmax} [N]	N	Bezeichnung Description	Gewicht [g] Weight [g]	Teil-Nr. Part #
nicht aushängbar Non-detachable	15.0	15.0	26.0	26.0	380	500		25/25	32.0	095K2525F00
	15.0	15.0	26.0	26.0	380	500	6	25/25	32.0	095K2525F06
	15.0	15.0	26.0	26.0	380	500	8	25/25	32.0	095K2525F08
	15.0	17.5	26.0	29.5	400	750		25/30	34.0	095K2530F00
	15.0	20.0	26.0	36.0	400	750		25/35	36.0	095K2535F00
	15.0	22.5	26.0	38.5	450	750		25/40	38.0	095K2540F00
	15.0	25.0	26.0	43.5	450	750		25/45	39.0	095K2545F00
	15.0	27.5	26.0	48.5	425	800		25/50	41.0	095K2550F00
	15.0	32.5	26.0	57.5	200	850		25/60	41.0	095K2560F00

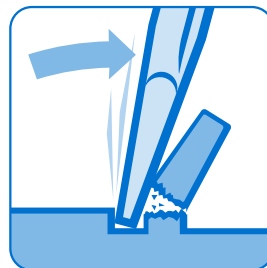

Scharniere Hinges

Kunststoffscharniere Plastic Hinges

Kombischarniere Combi Hinges



KUNSTSTOFF-KOMBISCHARNIER 30

PLASTIC COMBI HINGE 30

Ausführung	aushängbar	Model	Detachable
Beschreibung	für Flächenelemente und Aluminiumprofile	Description	To hinge panels or aluminum profiles
Material	Flügel: Kunststoff PA, glasfaserverstärkt; Achse: Edelstahl	Material	Wings: Plastic PA, glass fiber reinforced; Axle: Stainless steel
Befestigung	vorderseitig mit Senkschrauben M6	Fastening	From the front, using M6 countersunk screws
Liefereinheit	10 Stück	Pack Quantity	10 pieces
Extras	⚡ elektrostatisch entladend, weitere Farben, Führungsnasen zur Montage auf Aluminiumprofilen auf Anfrage	Specials	⚡ electrostatically discharging, further colors, fixing pins for installation on aluminum profiles available on request

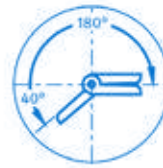
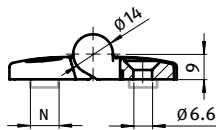
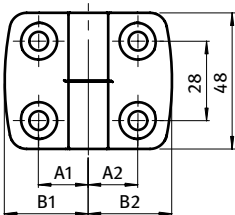

Scharnier Hinge	A1 [mm]	A2 [mm]	B1 [mm]	B2 [mm]	F _{Amax} [N]	F _{Rmax} [N]	N	Bezeichnung Description	Gewicht [g] Weight [g]	Teil-Nr. Part #
L: links Left	17.5	17.5	29.5	29.5	500	750		30/30	34.0	095K3030L00
	17.5	17.5	29.5	29.5	500	750	6	30/30	34.0	095K3030L06
	17.5	17.5	29.5	29.5	500	750	8	30/30	34.0	095K3030L08
	17.5	15.0	29.5	26.0	450	750		30/25	33.0	095K3025L00
	17.5	20.0	29.5	36.0	400	750		30/35	36.0	095K3035L00
	17.5	22.5	29.5	38.5	350	800		30/40	38.0	095K3040L00
	17.5	25.0	29.5	43.5	350	800		30/45	40.0	095K3045L00
	17.5	27.5	29.5	48.5	350	800		30/50	41.0	095K3050L00
	17.5	32.5	29.5	57.5	240	800		30/60	45.0	095K3060L00
R: rechts Right	17.5	17.5	29.5	29.5	500	750		30/30	34.0	095K3030R00
	17.5	17.5	29.5	29.5	500	750	6	30/30	34.0	095K3030R06
	17.5	17.5	29.5	29.5	500	750	8	30/30	34.0	095K3030R08
	15.0	17.5	26.0	29.5	450	750		30/25	33.0	095K3025R00
	20.0	17.5	36.0	29.5	400	700		30/35	36.0	095K3035R00
	22.5	17.5	38.5	29.5	350	800		30/40	38.0	095K3040R00
	25.0	17.5	43.5	29.5	350	800		30/45	40.0	095K3045R00
	27.5	17.5	48.5	29.5	350	800		30/50	41.0	095K3050R00
	32.5	17.5	57.5	29.5	240	800		30/60	45.0	095K3060R00

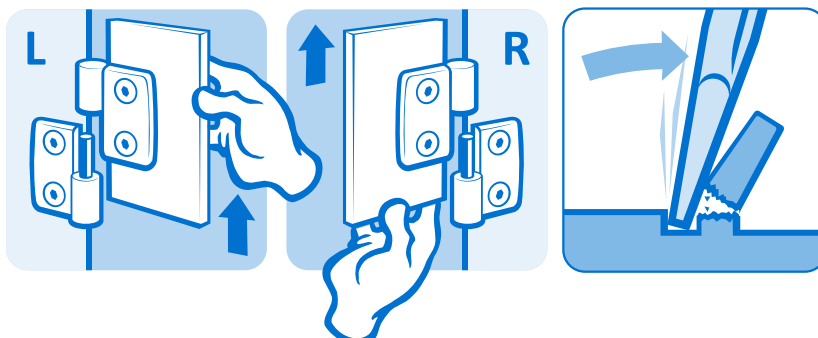

Scharniere Hinges

Kunststoffscharniere Plastic Hinges

Kombischarniere Combi Hinges



KUNSTSTOFF-KOMBISCHARNIER 30

PLASTIC COMBI HINGE 30

Ausführung	nicht aushängbar	Model	Non-detachable
Beschreibung	für Flächenelemente und Aluminiumprofile	Description	To hinge panels or aluminum profiles
Material	Flügel: Kunststoff PA, glasfaserverstärkt; Achse: Edelstahl	Material	Wings: Plastic PA, glass fiber reinforced; Axle: Stainless steel
Farbe	schwarz	Color	Black
Befestigung	vorderseitig mit Senkschrauben M6	Fastening	From the front, using M6 countersunk screws
Liefereinheit	10 Stück	Pack Quantity	10 pieces
Extras	☁ elektrostatisch entladend, weitere Farben, Führungsnasen zur Montage auf Aluminiumprofilen auf Anfrage	Specials	☁ electrostatically discharging, further colors, fixing pins for installation on aluminum profiles available on request

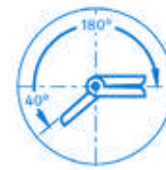
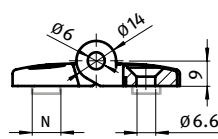
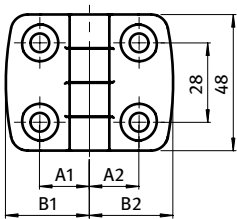

Kombischarnier Combi Hinge	A1 [mm]	A2 [mm]	B1 [mm]	B2 [mm]	F _{Amax} [N]	F _{Rmax} [N]	N	Bezeichnung Description	Gewicht [g] Weight [g]	Teil-Nr. Part #
nicht aushängbar Non-detachable	17.5	17.5	29.5	29.5	400	700		30/30	36.0	095K3030F00
	17.5	17.5	29.5	29.5	400	700	6	30/30	36.0	095K3030F06
	17.5	17.5	29.5	29.5	400	700	8	30/30	36.0	095K3030F08
	17.5	20.0	29.5	36.0	400	700		30/35	37.0	095K3035F00
	17.5	22.5	29.5	38.5	450	750		30/40	39.0	095K3040F00
	17.5	25.0	29.5	43.5	450	750		30/45	41.0	095K3045F00
	17.5	27.5	29.5	48.5	425	800		30/50	43.0	095K3050F00
	17.5	32.5	29.5	57.5	200	850		30/60	46.0	095K3060F00

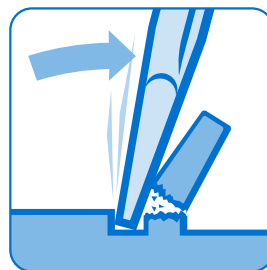

Scharniere Hinges

Kunststoffscharniere Plastic Hinges

Kombischarniere Combi Hinges

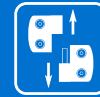

KUNSTSTOFF-KOMBISCHARNIER 35

PLASTIC COMBI HINGE 35

Ausführung	aushängbar	Model	Detachable
Beschreibung	für Flächenelemente und Aluminiumprofile	Description	To hinge panels or aluminum profiles
Material	Flügel: Kunststoff PA, glasfaserverstärkt; Achse: Edelstahl	Material	Wings: Plastic PA, glass fiber reinforced; Axle: Stainless steel
Befestigung	vorderseitig mit Senkschrauben M6	Fastening	From the front, using M6 countersunk screws
Liefereinheit	10 Stück	Pack Quantity	10 pieces
Extras	⚡ elektrostatisch entladend, weitere Farben, Führungsnasen zur Montage auf Aluminiumprofilen auf Anfrage	Specials	⚡ electrostatically discharging, further colors, fixing pins for installation on aluminum profiles available on request

2

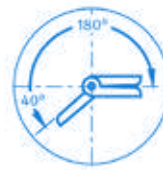
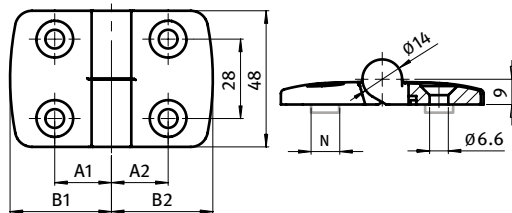

Kombischarnier Combi Hinge	A1 [mm]	A2 [mm]	B1 [mm]	B2 [mm]	F _{Amax} [N]	F _{Rmax} [N]	N	Bezeichnung Description	Gewicht [g] Weight [g]	Teil-Nr. Part #
L: links Left	20.0	20.0	36.0	36.0	400	750		35/35	38.0	095K3535L00
	20.0	20.0	36.0	36.0	400	750	8	35/35	38.0	095K3535L08
	20.0	20.0	36.0	36.0	400	750	10	35/35	38.0	095K3535L10
	20.0	15.0	36.0	26.0	400	750		35/25	34.0	095K3525L00
	20.0	17.5	36.0	29.5	500	750		35/30	36.0	095K3530L00
	20.0	22.5	36.0	38.5	350	800		35/40	40.0	095K3540L00
	20.0	25.0	36.0	43.5	350	800		35/45	42.0	095K3545L00
	20.0	27.5	36.0	48.5	350	900		35/50	43.0	095K3550L00
	20.0	32.5	36.0	57.5	240	800		35/60	47.0	095K3560L00
R: rechts Right	20.0	20.0	36.0	36.0	400	750		35/35	38.0	095K3535R00
	20.0	20.0	36.0	36.0	400	750	8	35/35	38.0	095K3535R08
	20.0	20.0	36.0	36.0	400	750	10	35/35	38.0	095K3535R10
	20.0	15.0	36.0	26.0	400	700		35/25	34.0	095K3525R00
	20.0	17.5	36.0	29.5	500	750		35/30	36.0	095K3530R00
	20.0	22.5	36.0	38.5	350	800		35/40	40.0	095K3540R00
	20.0	25.0	36.0	43.5	350	800		35/45	42.0	095K3545R00
	20.0	27.5	36.0	48.5	350	800		35/50	43.0	095K3550R00
	20.0	32.5	36.0	57.5	240	800		35/60	47.0	095K3560R00

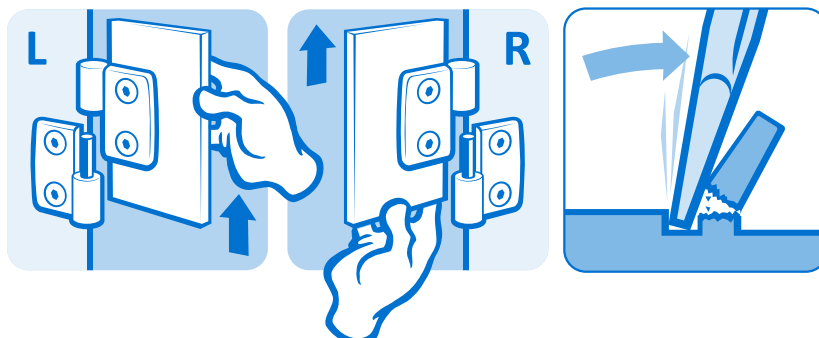

Scharniere Hinges

Kunststoffscharniere Plastic Hinges

Kombischarniere Combi Hinges



KUNSTSTOFF-KOMBISCHARNIER 35

PLASTIC COMBI HINGE 35

Ausführung	nicht aushängbar	Model	Non-detachable
Beschreibung	für Flächenelemente und Aluminiumprofile	Description	To hinge panels or aluminum profiles
Material	Flügel: Kunststoff PA, glasfaserverstärkt; Achse: Edelstahl	Material	Wings: Plastic PA, glass fiber reinforced; Axle: Stainless steel
Farbe	schwarz	Color	Black
Befestigung	vorderseitig mit Senkschrauben M6	Fastening	From the front, using M6 countersunk screws
Liefereinheit	10 Stück	Pack Quantity	10 pieces
Extras	☁ elektrostatisch entladend, weitere Farben, Führungsnasen zur Montage auf Aluminiumprofilen auf Anfrage	Specials	☁ electrostatically discharging, further colors, fixing pins for installation on aluminum profiles available on request

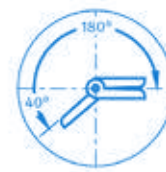
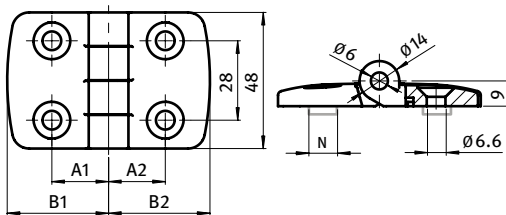

Kombischarnier Combi Hinge	A1 [mm]	A2 [mm]	B1 [mm]	B2 [mm]	F _{Amax} [N]	F _{Rmax} [N]	N	Bezeichnung Description	Gewicht [g] Weight [g]	Teil-Nr. Part #
nicht aushängbar Non-detachable	20.0	20.0	36.0	36.0	400	700		35/35	40.0	095K3535F00
	20.0	20.0	36.0	36.0	400	700	8	35/35	40.0	095K3535F08
	20.0	20.0	36.0	36.0	400	700	10	35/35	40.0	095K3535F10
	20.0	22.5	36.0	38.5	450	750		35/40	41.0	095K3540F00
	20.0	25.0	36.0	43.5	450	750		35/45	42.0	095K3545F00
	20.0	27.5	36.0	48.5	425	800		35/50	44.0	095K3550F00
	20.0	32.5	36.0	57.5	175	800		35/60	47.0	095K3560F00

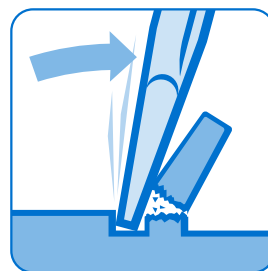

2

Scharniere Hinges

Kunststoffscharniere Plastic Hinges

Kombischarniere Combi Hinges



KUNSTSTOFF-KOMBISCHARNIER 40

PLASTIC COMBI HINGE 40

Ausführung	aushängbar	Model	Detachable
Beschreibung	für Flächenelemente und Aluminiumprofile	Description	To hinge panels or aluminum profiles
Material	Flügel: Kunststoff PA, glasfaserverstärkt; Achse: Edelstahl	Material	Wings: Plastic PA, glass fiber reinforced; Axle: Stainless steel
Befestigung	vorderseitig mit Senkschrauben M6	Fastening	From the front, using M6 countersunk screws
Liefereinheit	10 Stück	Pack Quantity	10 pieces
Extras	⚡ elektrostatisch entladend, weitere Farben, Führungsnasen zur Montage auf Aluminiumprofilen auf Anfrage	Specials	⚡ electrostatically discharging, further colors, fixing pins for installation on aluminum profiles available on request

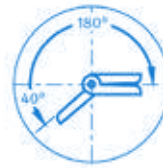
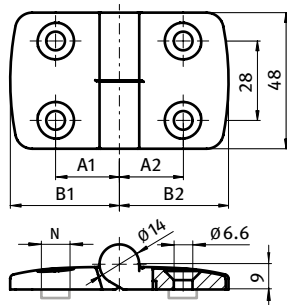

Kombischarnier Combi Hinge	A1 [mm]	A2 [mm]	B1 [mm]	B2 [mm]	F _{Amax} [N]	F _{Rmax} [N]	N	Bezeichnung Description	Gewicht [g] Weight [g]	Teil-Nr. Part #
L: links Left	22.5	22.5	38.5	38.5	400	800		40/40	42.0	095K4040L00
	22.5	22.5	38.5	38.5	400	800	8	40/40	42.0	095K4040L08
	22.5	22.5	38.5	38.5	400	800	10	40/40	42.0	095K4040L10
	22.5	15.0	38.5	26.0	425	650		40/25	37.0	095K4025L00
	22.5	17.5	38.5	29.5	500	750		40/30	38.0	095K4030L00
	22.5	20.0	38.5	36.0	400	750		40/35	40.0	095K4035L00
	22.5	25.0	38.5	43.5	350	800		40/45	43.0	095K4045L00
	22.5	27.5	38.5	48.5	350	800		40/50	45.0	095K4050L00
R: rechts Right	22.5	32.5	38.5	57.5	240	800		40/60	49.0	095K4060L00
	22.5	22.5	38.5	38.5	350	800		40/40	42.0	095K4040R00
	22.5	22.5	38.5	38.5	350	800	8	40/40	42.0	095K4040R08
	22.5	22.5	38.5	38.5	350	800	10	40/40	42.0	095K4040R10
	15.0	22.5	26.0	38.5	425	650		40/25	37.0	095K4025R00
	17.5	22.5	29.5	38.5	500	750		40/30	38.0	095K4030R00
	20.0	22.5	36.0	38.5	400	750		40/35	40.0	095K4035R00
	25.0	22.5	43.5	38.5	350	800		40/45	43.0	095K4045R00
27.5	22.5	48.5	38.5	350	800		40/50	45.0	095K4050R00	
32.5	22.5	57.5	38.5	240	800		40/60	49.0	095K4060R00	

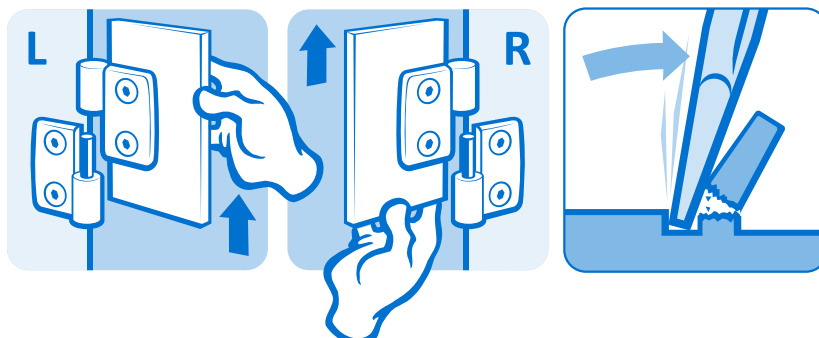

Scharniere Hinges

Kunststoffscharniere Plastic Hinges

Kombischarniere Combi Hinges



KUNSTSTOFF-KOMBISCHARNIER 40

PLASTIC COMBI HINGE 40

Ausführung nicht aushängbar
Beschreibung für Flächenelemente und Aluminiumprofile
Material Flügel: Kunststoff PA, glasfaserverstärkt;
 Achse: Edelstahl
Farbe schwarz
Befestigung vorderseitig mit Senkschrauben M6
Liefereinheit 10 Stück
Extras ⚡ elektrostatisch entladend, weitere Farben,
 Führungsnasen zur Montage auf Aluminiumprofilen auf Anfrage

Model Non-detachable
Description To hinge panels or aluminum profiles
Material Wings: Plastic PA, glass fiber reinforced;
 Axle: Stainless steel
Color Black
Fastening From the front, using M6 countersunk screws
Pack Quantity 10 pieces
Specials ⚡ electrostatically discharging, further colors,
 fixing pins for installation on aluminum profiles available on request

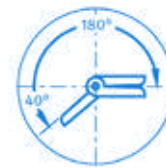
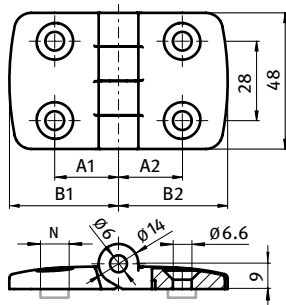

Kombischarnier Combi Hinge	A1 [mm]	A2 [mm]	B1 [mm]	B2 [mm]	F _{Amax} [N]	F _{Rmax} [N]	N	Bezeichnung Description	Gewicht [g] Weight [g]	Teil-Nr. Part #
nicht aushängbar Non-detachable	22.5	22.5	38.5	38.5	450	750		40/40	43.0	095K4040F00
	22.5	22.5	38.5	38.5	450	750	8	40/40	43.0	095K4040F08
	22.5	22.5	38.5	38.5	450	750	10	40/40	43.0	095K4040F10
	22.5	25.0	38.5	43.5	450	750		40/45	44.0	095K4045F00
	22.5	27.5	38.5	48.5	425	800		40/50	46.0	095K4050F00
	22.5	32.5	38.5	57.5	175	850		40/60	49.0	095K4060F00

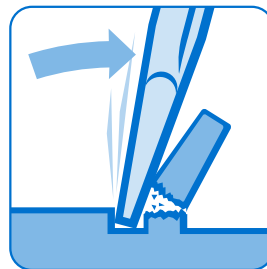

Scharniere Hinges

Kunststoffscharniere Plastic Hinges

Kombischarniere Combi Hinges



KUNSTSTOFF-KOMBISCHARNIER 45

PLASTIC COMBI HINGE 45

Ausführung	aushängbar	Model	Detachable
Beschreibung	für Flächenelemente und Aluminiumprofile	Description	To hinge panels or aluminum profiles
Material	Flügel: Kunststoff PA, glasfaserverstärkt Achse: Edelstahl	Material	Wings: Plastic PA, glass fiber reinforced Axle: Stainless steel
Befestigung	vorderseitig mit Senkschrauben M6	Fastening	From the front, using M6 countersunk screws
Liefereinheit	10 Stück	Pack Quantity	10 pieces
Extras	⚡ elektrostatisch entladend, weitere Farben, Führungsnasen zur Montage auf Aluminiumprofilen auf Anfrage	Specials	⚡ electrostatically discharging, further colors, fixing pins for installation on aluminum profiles available on request

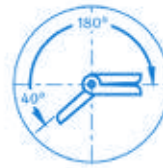
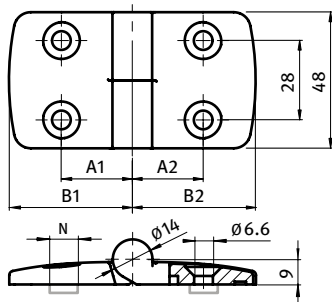

Kombischarnier Combi Hinge	A1 [mm]	A2 [mm]	B1 [mm]	B2 [mm]	FMax [N]	FRmax [N]	N	Bezeichnung Description	Gewicht [g] Weight [g]	Teil-Nr. Part #
L: links Left	25.0	25.0	43.5	43.5	325	800		45/45	45.0	095K4545L00
	25.0	25.0	43.5	43.5	325	800	8	45/45	45.0	095K4545L08
	25.0	25.0	43.5	43.5	325	800	10	45/45	45.0	095K4545L10
	25.0	15.0	43.5	26.0	425	650		45/25	38.0	095K4525L00
	25.0	17.5	43.5	29.5	500	750		45/30	40.0	095K4530L00
	25.0	20.0	43.5	36.0	400	700		45/35	42.0	095K4535L00
	25.0	22.5	43.5	38.5	350	800		45/40	43.0	095K4540L00
	25.0	27.5	43.5	48.5	320	800		45/50	46.0	095K4550L00
	25.0	32.5	43.5	57.5	240	800		45/60	50.0	095K4560L00
R: rechts Right	25.0	25.0	43.5	43.5	325	800		45/45	45.0	095K4545R00
	25.0	25.0	43.5	43.5	325	800	8	45/45	45.0	095K4545R08
	25.0	25.0	43.5	43.5	325	800	10	45/45	45.0	095K4545R10
	15.0	25.0	26.0	43.5	425	650		45/25	38.0	095K4525R00
	17.5	25.0	29.5	43.5	500	750		45/30	40.0	095K4530R00
	20.0	25.0	36.0	43.5	325	800		45/35	42.0	095K4535R00
	22.5	25.0	38.5	43.5	350	800		45/40	43.0	095K4540R00
	27.5	25.0	48.5	43.5	320	800		45/50	45.0	095K4550R00
	32.5	25.0	57.5	43.5	240	800		45/60	50.0	095K4560R00

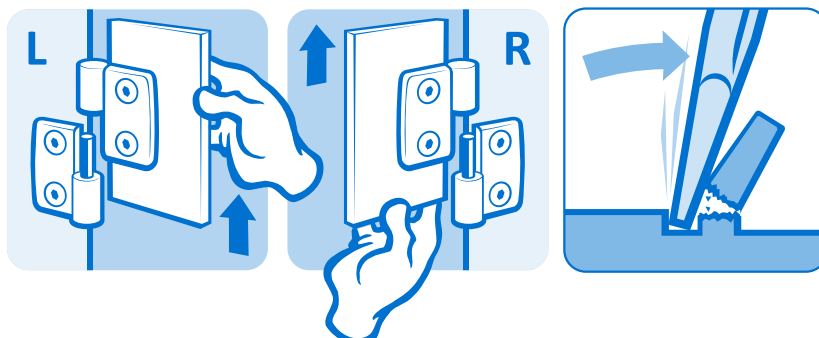

Scharniere Hinges

Kunststoffscharniere Plastic Hinges

Kombischarniere Combi Hinges



KUNSTSTOFF-KOMBISCHARNIER 45

PLASTIC COMBI HINGE 45

Ausführung nicht aushängbar
Beschreibung für Flächenelemente und Aluminiumprofile
Material Flügel: Kunststoff PA, glasfaserverstärkt
 Achse: Edelstahl
Farbe schwarz
Befestigung vorderseitig mit Senkschrauben M6
Liefereinheit 10 Stück
Extras ⚡ elektrostatisch entladend, weitere Farben,
 Führungsnasen zur Montage auf Aluminiumprofilen auf Anfrage

Model Non-detachable
Description To hinge panels or aluminum profiles
Material Wings: Plastic PA, glass fiber reinforced
 Axle: Stainless steel
Color Black
Fastening From the front, using M6 countersunk screws
Pack Quantity 10 pieces
Specials ⚡ electrostatically discharging, further colors,
 fixing pins for installation on aluminum profiles available on request

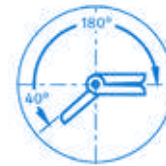
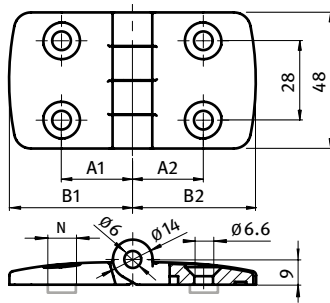

Kombischarnier Combi Hinge	A1 [mm]	A2 [mm]	B1 [mm]	B2 [mm]	FMax [N]	FRmax [N]	N	Bezeichnung Description	Gewicht [g] Weight [g]	Teil-Nr. Part #
nicht aushängbar Non-detachable	25.0	25.0	43.5	43.5	450	750		45/45	46.0	095K4545F00
	25.0	25.0	43.5	43.5	450	750	8	45/45	46.0	095K4545F08
	25.0	25.0	43.5	43.5	450	750	10	45/45	46.0	095K4545F10
	25.0	27.5	43.5	48.5	425	800		45/50	48.0	095K4550F00
	25.0	32.5	43.5	57.5	200	850		45/60	51.0	095K4560F00

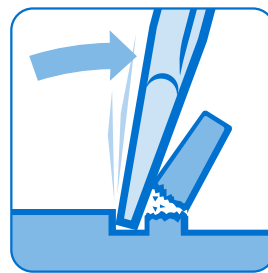

Scharniere Hinges

Kunststoffscharniere Plastic Hinges

Kombischarniere Combi Hinges



KUNSTSTOFF-KOMBISCHARNIER 50

PLASTIC COMBI HINGE 50

Ausführung	aushängbar	Model	Detachable
Beschreibung	für Flächenelemente und Aluminiumprofile	Description	To hinge panels or aluminum profiles
Material	Flügel: Kunststoff PA, glasfaserverstärkt Achse: Edelstahl	Material	Wings: Plastic PA, glass fiber reinforced Axle: Stainless steel
Befestigung	vorderseitig mit Senkschrauben M6	Fastening	From the front, using M6 countersunk screws
Liefereinheit	10 Stück	Pack Quantity	10 pieces
Extras	⚡ elektrostatisch entladend, weitere Farben, Führungsnasen zur Montage auf Aluminiumprofilen auf Anfrage	Specials	⚡ electrostatically discharging, further colors, fixing pins for installation on aluminum profiles available on request

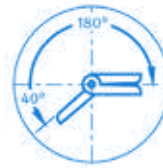
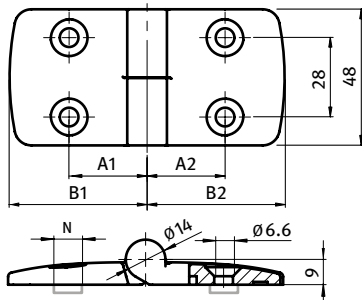

Kombischarnier Combi Hinge	A1 [mm]	A2 [mm]	B1 [mm]	B2 [mm]	F _{Amax} [N]	F _{Rmax} [N]	N	Bezeichnung Description	Gewicht [g] Weight [g]	Teil-Nr. Part #
L: links <i>Left</i>	27.5	27.5	48.5	48.5	320	800		50/50	48.0	095K5050L00
	27.5	27.5	48.5	48.5	320	800	8	50/50	48.0	095K5050L08
	27.5	27.5	48.5	48.5	320	800	10	50/50	48.0	095K5050L10
	27.5	15.0	48.5	26.0	425	650		50/25	40.0	095K5025L00
	27.5	17.5	48.5	29.5	500	750		50/30	41.0	095K5030L00
	27.5	20.0	48.5	36.0	400	700		50/35	43.0	095K5035L00
	27.5	22.5	48.5	38.5	350	800		50/40	45.0	095K5040L00
	27.5	25.0	48.5	43.5	325	800		50/45	46.0	095K5045L00
	27.5	32.5	48.5	57.5	240	800		50/60	52.0	095K5060L00
R: rechts <i>Right</i>	27.5	27.5	48.5	48.5	320	800		50/50	48.0	095K5050R00
	27.5	27.5	48.5	48.5	320	800	8	50/50	48.0	095K5050R08
	27.5	27.5	48.5	48.5	320	800	10	50/50	48.0	095K5050R10
	15.0	27.5	26.0	48.5	425	650		50/25	40.0	095K5025R00
	17.5	27.5	29.5	48.5	500	750		50/30	41.0	095K5030R00
	20.0	27.5	36.0	48.5	400	700		50/35	43.0	095K5035R00
	22.5	27.5	38.5	48.5	350	800		50/40	45.0	095K5040R00
	25.0	27.5	43.5	48.5	325	800		50/45	46.0	095K5045R00
	32.5	27.5	57.5	48.5	240	800		50/60	52.0	095K5060R00

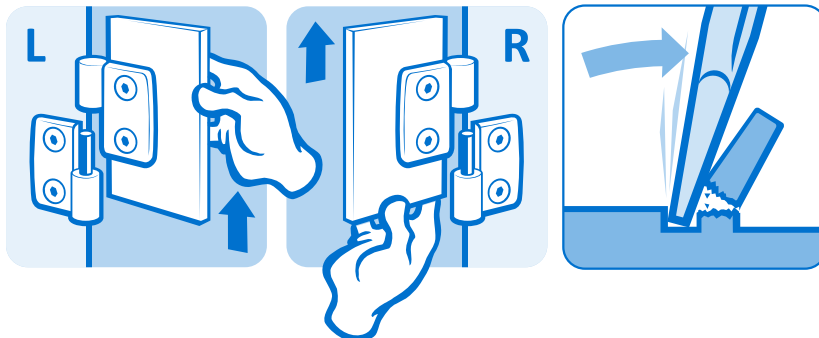

Scharniere Hinges

Kunststoffscharniere Plastic Hinges

Kombischarniere Combi Hinges



KUNSTSTOFF-KOMBISCHARNIER 50

PLASTIC COMBI HINGE 50

Ausführung	nicht aushängbar	Model	Non-detachable
Beschreibung	für Flächenelemente und Aluminiumprofile	Description	To hinge panels or aluminum profiles
Material	Flügel: Kunststoff PA, glasfaserverstärkt Achse: Edelstahl	Material	Wings: Plastic PA, glass fiber reinforced Axle: Stainless steel
Farbe	schwarz	Color	Black
Befestigung	vorderseitig mit Senkschrauben M6	Fastening	From the front, using M6 countersunk screws
Liefereinheit	10 Stück	Pack Quantity	10 pieces
Extras	☁ elektrostatisch entladend, weitere Farben, Führungsnasen zur Montage auf Aluminiumprofilen auf Anfrage	Specials	☁ electrostatically discharging, further colors, fixing pins for installation on aluminum profiles available on request

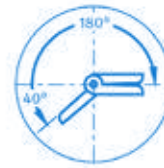
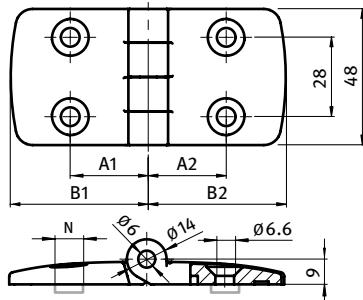

Kombischarnier Combi Hinge	A1 [mm]	A2 [mm]	B1 [mm]	B2 [mm]	F _{Amax} [N]	F _{Rmax} [N]	N	Bezeichnung Description	Gewicht [g] Weight [g]	Teil-Nr. Part #
nicht aushängbar Non-detachable	27.5	27.5	48.5	48.5	425	800		50/50	49.0	095K5050F00
	27.5	27.5	48.5	48.5	425	800	8	50/50	49.0	095K5050F08
	27.5	27.5	48.5	48.5	425	800	10	50/50	49.0	095K5050F10
	27.5	32.5	48.5	57.5	200	850		50/60	52.0	095K5060F00

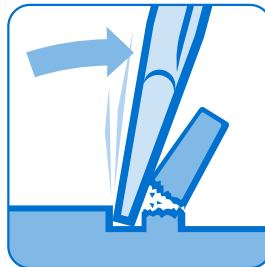

Scharniere Hinges

Kunststoffscharniere Plastic Hinges

Kombischarniere Combi Hinges

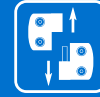

KUNSTSTOFF-KOMBISCHARNIER 60

PLASTIC COMBI HINGE 60

Ausführung	aushängbar	Model	Detachable
Beschreibung	für Flächenelemente und Aluminiumprofile	Description	To hinge panels or aluminum profiles
Material	Flügel: Kunststoff PA, glasfaserverstärkt Achse: Edelstahl	Material	Wings: Plastic PA, glass fiber reinforced Axle: Stainless steel
Befestigung	vorderseitig mit Senkschrauben M6	Fastening	From the front, using M6 countersunk screws
Liefereinheit	10 Stück	Pack Quantity	10 pieces
Extras	☁ elektrostatisch entladend, weitere Farben, Führungsnasen zur Montage auf Aluminiumprofilen auf Anfrage	Specials	☁ electrostatically discharging, further colors, fixing pins for installation on aluminum profiles available on request

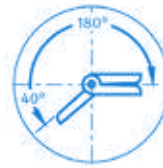
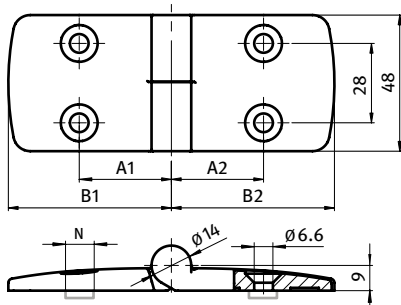

Kombischarnier Combi Hinge	A1 [mm]	A2 [mm]	B1 [mm]	B2 [mm]	F _{Amax} [N]	F _{Rmax} [N]	N	Bezeichnung Description	Gewicht [g] Weight [g]	Teil-Nr. Part #
L: links <i>Left</i>	32.5	32.5	57.5	57.5	240	900		60/60	55.0	095K6060L00
	32.5	32.5	57.5	57.5	240	900	8	60/60	55.0	095K6060L08
	32.5	32.5	57.5	57.5	240	900	10	60/60	55.0	095K6060L10
	32.5	15.0	57.5	26.0	425	650		60/25	43.0	095K6025L00
	32.5	17.5	57.5	29.5	500	750		60/30	45.0	095K6030L00
	32.5	20.0	57.5	36.0	400	700		60/35	47.0	095K6035L00
	32.5	22.5	57.5	38.5	350	800		60/40	49.0	095K6040L00
	32.5	25.0	57.5	43.5	325	800		60/45	50.0	095K6045L00
	32.5	27.5	57.5	48.5	320	900		60/50	52.0	095K6050L00
R: rechts <i>Right</i>	32.5	32.5	57.5	57.5	240	900		60/60	55.0	095K6060R00
	32.5	32.5	57.5	57.5	240	900	8	60/60	55.0	095K6060R08
	32.5	32.5	57.5	57.5	240	900	10	60/60	55.0	095K6060R10
	15.0	32.5	26.0	57.5	425	650		60/25	43.0	095K6025R00
	17.5	32.5	29.5	57.5	500	750		60/30	45.0	095K6030R00
	20.0	32.5	36.0	57.5	400	700		60/35	47.0	095K6035R00
	22.5	32.5	38.5	57.5	350	800		60/40	49.0	095K6040R00
	25.0	32.5	43.5	57.5	325	800		60/45	50.0	095K6045R00
	27.5	32.5	48.5	57.5	320	900		60/50	52.0	095K6050R00

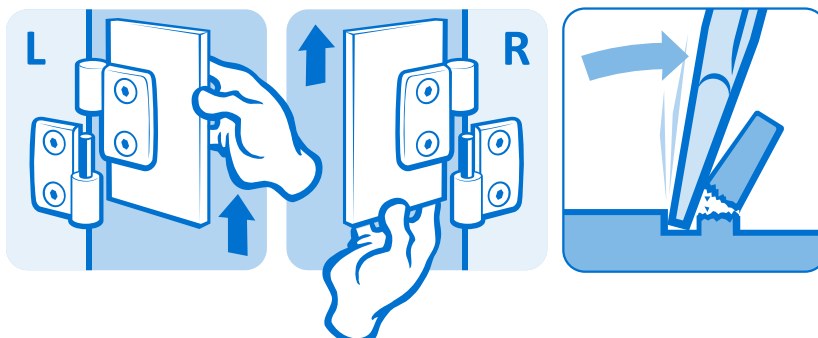

Scharniere Hinges

Kunststoffscharniere Plastic Hinges

Kombischarniere Combi Hinges



KUNSTSTOFF-KOMBISCHARNIER 60

PLASTIC COMBI HINGE 60

Ausführung nicht aushängbar
Beschreibung für Flächenelemente und Aluminiumprofile
Material Flügel: Kunststoff PA, glasfaserverstärkt
 Achse: Edelstahl
Farbe schwarz
Befestigung vorderseitig mit Senkschrauben M6
Liefereinheit 10 Stück
Extras ⚡ elektrostatisch entladend, weitere Farben,
 Führungsnasen zur Montage auf Aluminiumprofilen auf Anfrage

Model Non-detachable
Description To hinge panels or aluminum profiles
Material Wings: Plastic PA, glass fiber reinforced
 Axle: Stainless steel
Color Black
Fastening From the front, using M6 countersunk screws
Pack Quantity 10 pieces
Specials ⚡ electrostatically discharging, further colors,
 fixing pins for installation on aluminum profiles available on request

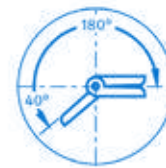
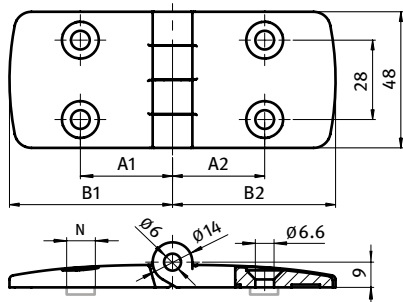

Kombischarnier Combi Hinge	A1 [mm]	A2 [mm]	B1 [mm]	B2 [mm]	F _{Amax} [N]	F _{Rmax} [N]	N	Bezeichnung Description	Gewicht [g] Weight [g]	Teil-Nr. Part #
nicht aushängbar Non-detachable	32.5	32.5	57.5	57.5	175	850		60/60	55.0	095K6060F00
	32.5	32.5	57.5	57.5	175	850	8	60/60	55.0	095K6060F08
	32.5	32.5	57.5	57.5	175	850	10	60/60	55.0	095K6060F10

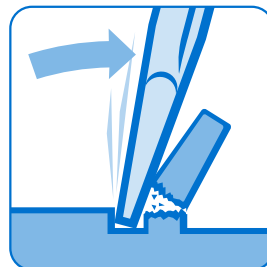

2

Scharniere Hinges

Kunststoffscharniere Plastic Hinges

Kombischarniere Combi Hinges



KOMBISCHARNIER MIT KLEMMHEBEL

COMBI HINGE WITH LOCKING LEVER

Ausführung	Kunststoff PA, nicht aushängbar	Model	Plastic PA, non-detachable
Beschreibung	für Flächenelemente und Aluminiumprofile; in jeder Position fixierbar	Description	To hinge panels or aluminum profiles; can be locked at any position
Material	Scharnier: Kunststoff PA, glasfaserverstärkt Klemmhebel: Kunststoff PA, glasfaserverstärkt Mechanik: Stahl, verzinkt (RoHS-konform)	Material	Hinge: Plastic PA, glass fiber reinforced locking lever: Plastic PA, glass fiber reinforced Mechanism: Steel, zinc plated (RoHS conform)
Farbe	schwarz	Color	Black
Befestigung	vorderseitig mit Senkschrauben M6	Fastening	From the front, using M6 countersunk screws
Liefereinheit	10 Stück	Pack Quantity	10 pieces
Extras	☁ elektrostatisch entladend, weitere Größen, weitere Farben auf Anfrage	Specials	☁ electrostatically discharging, other sizes, other colors on request
Hinweis	Kombinationen unterschiedlicher Flügel auf Anfrage	Tip	Combinations of different wing sizes are available on request

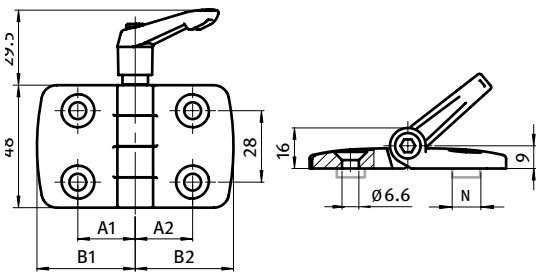

Kombischarnier Combi Hinge	A1 [mm]	A2 [mm]	B1 [mm]	B2 [mm]	F _{Amax} [N]	F _{Rmax} [N]	N	Gewicht [g] Weight [g]	Teil-Nr. Part #
25/25	15.0	15.0	26.0	26.0	380	500		43.0	095KF2525F00
	15.0	15.0	26.0	26.0	380	500	6	43.0	095KF2525F06
	15.0	15.0	26.0	26.0	380	500	8	43.0	095KF2525F08
30/30	17.5	17.5	29.5	29.5	400	700		47.0	095KF3030F00
	17.5	17.5	29.5	29.5	400	700	6	47.0	095KF3030F06
	17.5	17.5	29.5	29.5	400	700	8	47.0	095KF3030F08
35/35	20.0	20.0	36.0	36.0	400	700		51.0	095KF3535F00
	20.0	20.0	36.0	36.0	400	700	8	51.0	095KF3535F08
	20.0	20.0	36.0	36.0	400	700	10	51.0	095KF3535F10
40/40	22.5	22.5	38.5	38.5	450	750		55.0	095KF4040F00
	22.5	22.5	38.5	38.5	450	750	8	55.0	095KF4040F08
	22.5	22.5	38.5	38.5	450	750	10	55.0	095KF4040F10
45/45	25.0	25.0	43.5	43.5	450	750		57.0	095KF4545F00
	25.0	25.0	43.5	43.5	450	750	8	57.0	095KF4545F08
	25.0	25.0	43.5	43.5	450	750	10	57.0	095KF4545F10
50/50	27.5	27.5	48.5	48.5	425	800		62.0	095KF5050F00
	27.5	27.5	48.5	48.5	425	800	8	62.0	095KF5050F08
	27.5	27.5	48.5	48.5	425	800	10	62.0	095KF5050F10
60/60	32.5	32.5	57.5	57.5	175	850		67.0	095KF6060F00
	32.5	32.5	57.5	57.5	175	850	8	67.0	095KF6060F08
	32.5	32.5	57.5	57.5	175	850	10	67.0	095KF6060F10

Scharniere Hinges
Kunststoffscharniere Plastic Hinges
Systemscharniere System Hinge



SYSTEMSCHARNIER 30

SYSTEM HINGE 30

Ausführung	mit Abdeckkappen	Model	With cover caps
Beschreibung	für Flächenelemente und Aluminiumprofile, mit Abdeckkappen	Description	To hinge panels or aluminum profiles, with cover caps
Material	Kunststoff PA, glasfaserverstärkt	Material	Plastic PA, glass fiber reinforced
Farbe	schwarz	Color	Black
Befestigung	vorderseitig mit Schrauben M6, rückseitig mit Sechskantmuttern und Schrauben	Fastening	From the front using M6 screws, from the back using hexagon nuts and screws
Liefereinheit	10 Stück	Pack Quantity	10 pieces
Extras	☁elektrostatisch entladend, weitere Größen, weitere Farben auf Anfrage	Specials	☁electrostatically discharging, other sizes, other colors on request
Hinweis	Kombinationen unterschiedlicher Flügel auf Anfrage	Tip	Combinations of different wing sizes are available on request

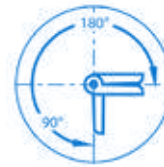
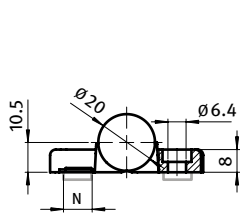
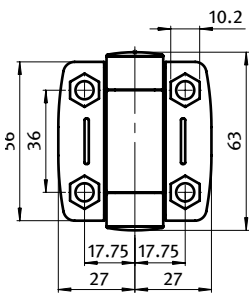

Systemscharnier System Hinge	FMax [N]	FRmax [N]	N	Gewicht [g] Weight [g]	Teil-Nr. Part #
	350	400		39.0	095S3030A00
	350	400	6	39.0	095S3030A06
	350	400	8	39.0	095S3030A08

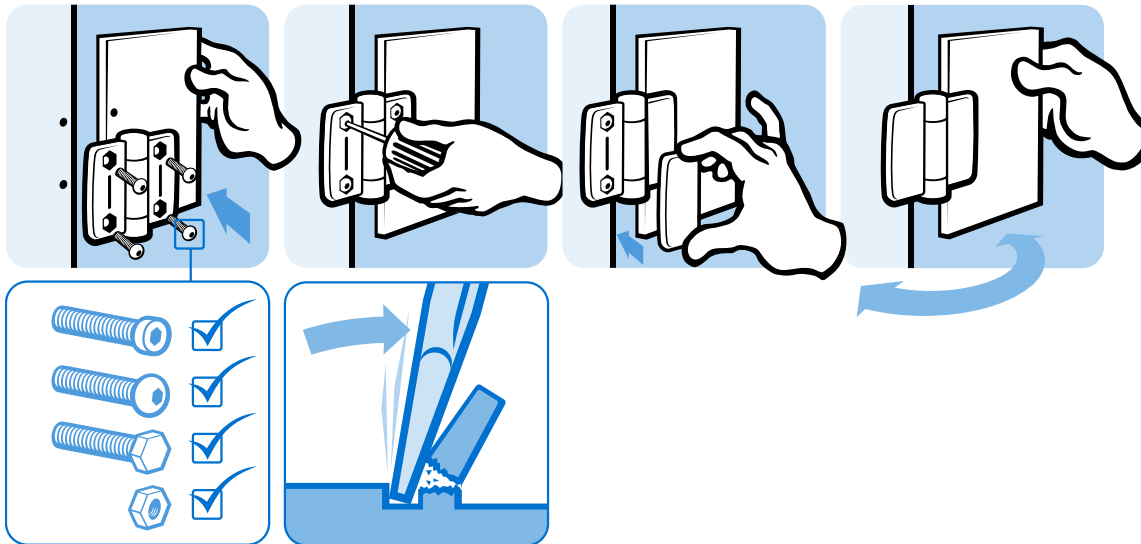

Scharniere Hinges

Kunststoffscharniere Plastic Hinges

Systemscharniere System Hinge



SYSTEMSCHARNIER 40

SYSTEM HINGE 40

Ausführung	mit Abdeckkappen	Model	With cover caps
Beschreibung	für Flächenelemente und Aluminiumprofile; mit Abdeckkappen	Description	To hinge panels or aluminum profiles; with cover caps
Material	Kunststoff PA, glasfaserverstärkt	Material	Plastic PA, glass fiber reinforced
Farbe	schwarz	Color	Black
Befestigung	vorderseitig mit Schrauben M6, rückseitig mit Sechskantmuttern und Schrauben	Fastening	From the front using M6 screws, from the back using hexagon nuts and screws
Liefereinheit	10 Stück	Pack Quantity	10 pieces
Extras	☁ elektrostatisch entladend, weitere Größen, weitere Farben auf Anfrage	Specials	☁ electrostatically discharging, other sizes, other colors on request
Hinweis	Kombinationen unterschiedlicher Flügel auf Anfrage	Tip	Combinations of different wing sizes are available on request

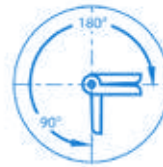
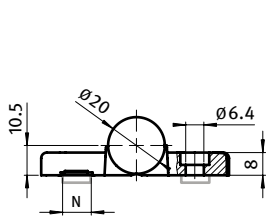
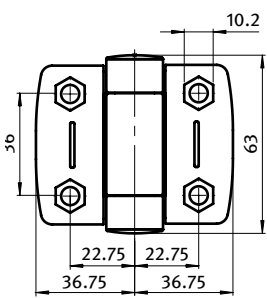

Systemscharnier System Hinge	F _{max} [N]	FR _{max} [N]	N	Gewicht [g] Weight [g]	Teil-Nr. Part #
	425	600		51.0	095S4040A00
	425	600	8	51.0	095S4040A08
	425	600	10	51.0	095S4040A10

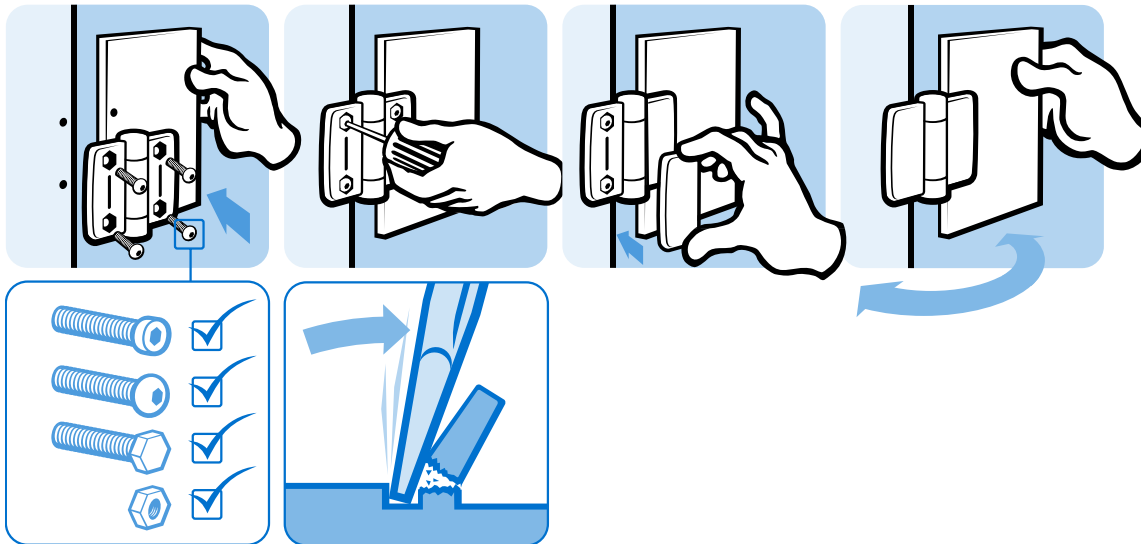

Scharniere Hinges

Kunststoffscharniere Plastic Hinges

Systemscharniere System Hinge



SYSTEMSCHARNIER 30 MIT RAST-FUNKTION

SYSTEM HINGE 30 WITH POSITIONING FUNCTION

Ausführung	mit Abdeckkappen	Model	With cover caps
Beschreibung	für Flächenelemente und Aluminiumprofile, mit Abdeckkappen, hält Türen und Klappen im Winkel von 85° oder 175° offen bzw. hält sie sicher verschlossen	Description	To hinge panels or aluminum profiles, with cover caps; to hold doors open at an angle at 85° or 175° or to keep them securely closed
Material	Flügel: Kunststoff PA, glasfaserverstärkt Achse: Edelstahl	Material	Wings: Plastic PA, glass fiber reinforced Axle: Stainless steel
Farbe	schwarz	Color	Black
Befestigung	vorderseitig mit Schrauben M6, rückseitig mit Sechskantmuttern und Schrauben	Fastening	From the front using M6 screws, from the back using hexagon nuts and screws
Liefereinheit	10 Stück	Pack Quantity	10 pieces
Extras	☁elektrostatisch entladend, weitere Größen, weitere Farben auf Anfrage	Specials	☁electrostatically discharging, other sizes, other colors on request
Hinweis	Kombinationen unterschiedlicher Flügel auf Anfrage; * ± 25% des Sollwertes	Tip	Combinations of different wing sizes are available on request * ± 25% of the setting value

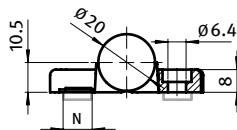
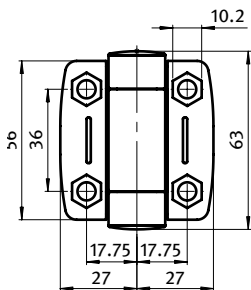

Systemscharnier System Hinge	F _{Am} [N]	F _R max [N]	N	Rastmoment* [Nm] Cogging Torque* [Nm]	Gewicht [g] Weight [g]	Teil-Nr. Part #
	350	400		2.0	73.0	095SR3030A00
	350	400	6	2.0	73.0	095SR3030A06
	350	400	8	2.0	73.0	095SR3030A08

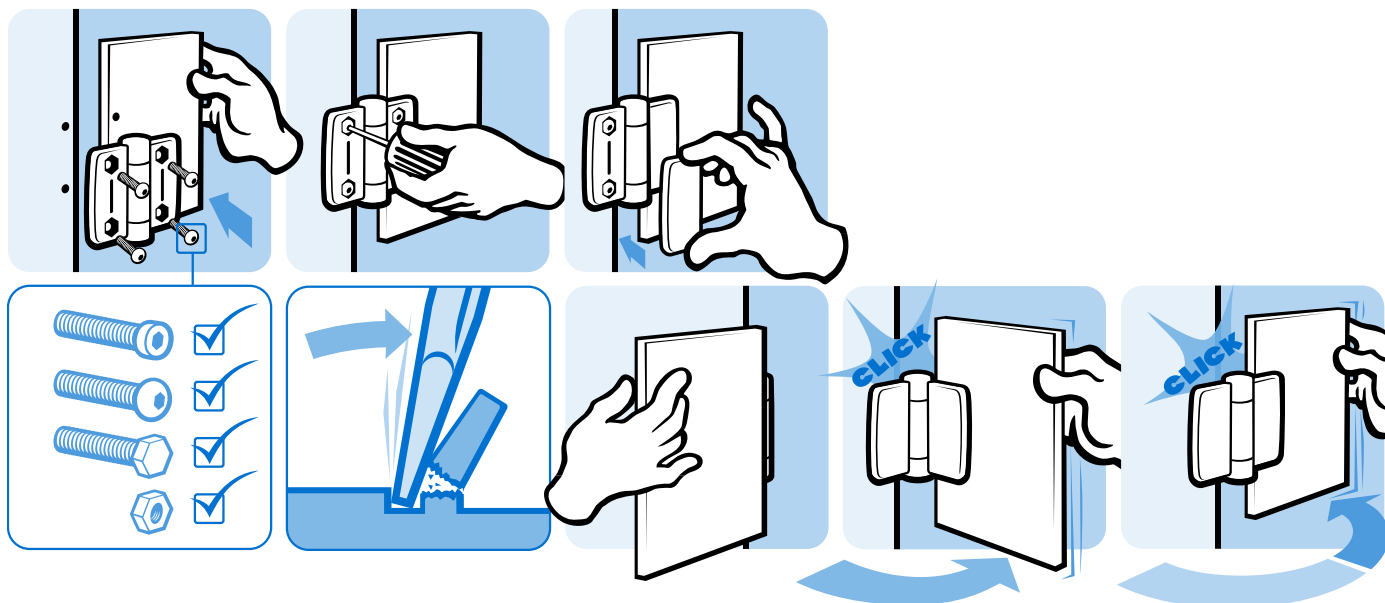

Scharniere Hinges

Kunststoffscharniere Plastic Hinges

Systemscharniere System Hinge



SYSTEMSCHARNIER 40 MIT RAST-FUNKTION

SYSTEM HINGE 40 WITH POSITIONING FUNCTION

<p>Ausführung mit Abdeckkappen</p> <p>Beschreibung für Flächenelemente und Aluminiumprofile, mit Abdeckkappen, hält Türen und Klappen im Winkel von 85° oder 175° offen bzw. hält sie sicher verschlossen</p> <p>Material Flügel: Kunststoff PA, glasfaserverstärkt Achse: Edelstahl</p> <p>Farbe schwarz</p> <p>Befestigung vorderseitig mit Schrauben M6, rückseitig mit Sechskantmuttern und Schrauben</p> <p>Liefereinheit 10 Stück</p> <p>Extras elektrostatisch entladend, weitere Größen, weitere Farben auf Anfrage</p> <p>Hinweis Kombinationen unterschiedlicher Flügel auf Anfrage; * ± 25% des Sollwertes</p>	<p>Model With cover caps</p> <p>Description To hinge panels or aluminum profiles, with cover caps; to hold doors open at an angle at 85° or 175° or to keep them securely closed</p> <p>Material Wings: Plastic PA, glass fiber reinforced Axle: Stainless steel</p> <p>Color Black</p> <p>Fastening From the front using M6 screws, from the back using hexagon nuts and screws</p> <p>Pack Quantity 10 pieces</p> <p>Specials electrostatically discharging, other sizes, other colors on request</p> <p>Tip Combinations of different wing sizes are available on request * ± 25% of the setting value</p>
--	--

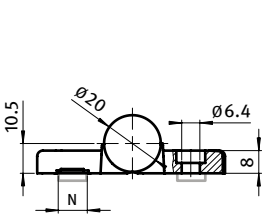
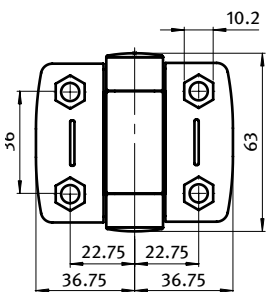

Systemscharnier System Hinge	F _{Amax} [N]	F _{Rmax} [N]	N	Rastmoment* [Nm] Cogging Torque* [Nm]	Gewicht [g] Weight [g]	Teil-Nr. Part #
	425	600		2.0	93.0	095SR4040A00
	425	600	8	2.0	93.0	095SR4040A08
	425	600	10	2.0	93.0	095SR4040A10

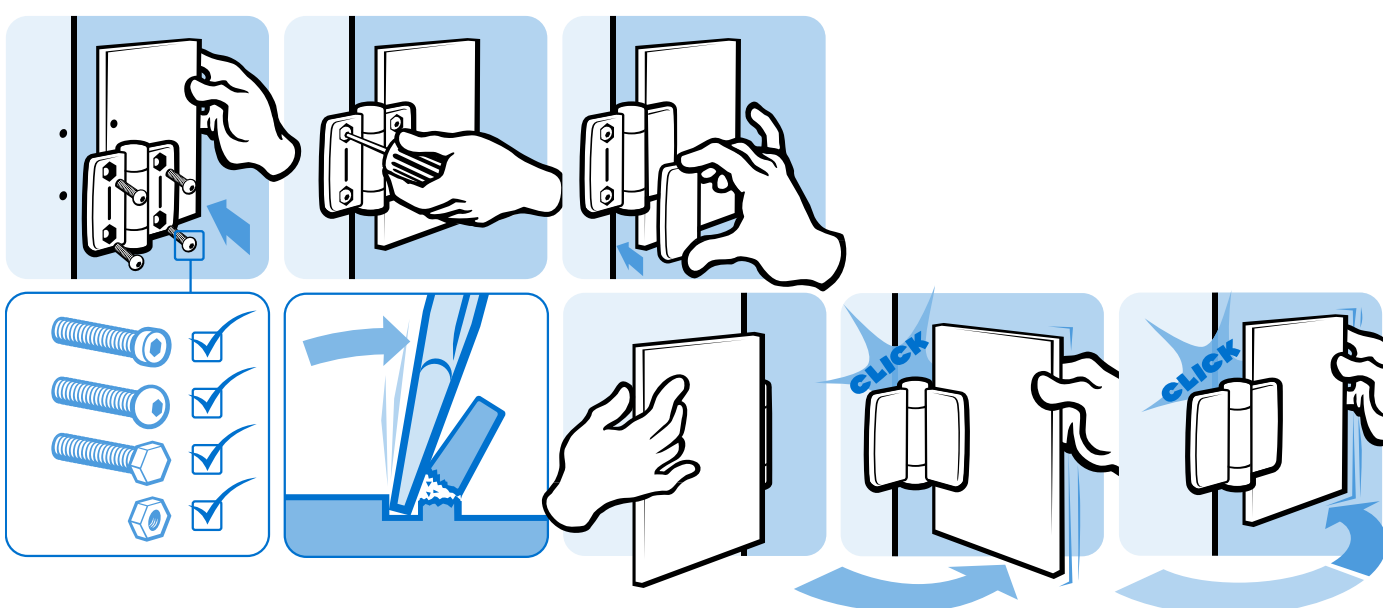

Scharniere Hinges

Kunststoffscharniere Plastic Hinges

Systemscharniere System Hinge



SYSTEMSCHARNIER 30 MIT EINSTELLBARER FRIKTION SYSTEM HINGE 30 WITH ADJUSTABLE FRICTION

Ausführung	mit Abdeckkappen	Model	With cover caps
Beschreibung	für Flächenelemente und Aluminiumprofile, hält Türen und Klappen in jedem Winkel fest; stufenlos einstellbar von 0 - 5 Nm Drehmoment; auch als Aufsteller für leichte Klappen einsetzbar	Description	For panels and aluminum profiles; to hold doors open at any angle; continuously variable from 0 - 5 Nm hinge moment; also supports lightweight horizontal doors
Material	Flügel: Kunststoff PA, glasfaserverstärkt Achse: Edelstahl	Material	Wings: Plastic PA, glass fiber reinforced Axle: Stainless steel
Farbe	schwarz	Color	Black
Befestigung	vorderseitig mit Schrauben M6, rückseitig mit Sechskantmuttern und Schrauben	Fastening	From the front using M6 screws, from the back using hexagon nuts and screws
Liefereinheit	10 Stück	Pack Quantity	10 pieces
Extras	☁elektrostatisch entladend, weitere Größen, weitere Farben auf Anfrage	Specials	☁electrostatically discharging, other sizes, other colors on request
Hinweis	Kombinationen unterschiedlicher Flügel auf Anfrage	Tip	Combinations of different wing sizes are available on request



Systemscharnier System Hinge	F _{Amax} [N]	F _{Rmax} [N]	N	Friktionsmoment [Nm] Friction Moment [Nm]	Gewicht [g] Weight [g]	Teil-Nr. Part #
	325	400		0-5	51.7	095SF3030A00
	325	400	6	0-5	51.7	095SF3030A06
	325	400	8	0-5	51.7	095SF3030A08

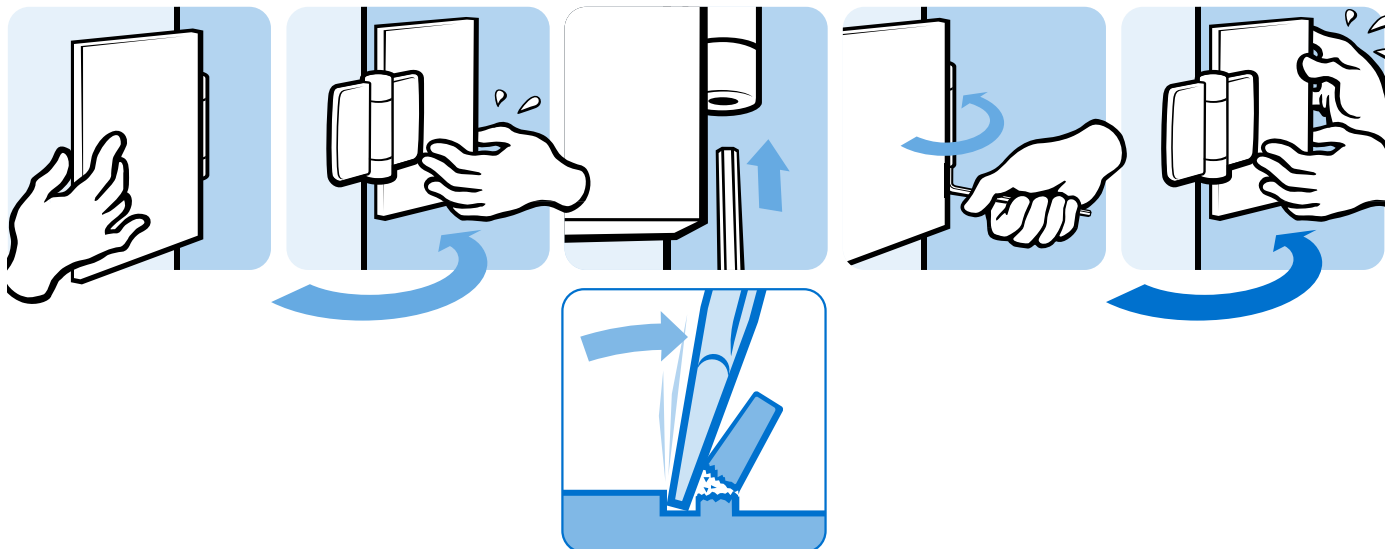

Scharniere Hinges

Kunststoffscharniere Plastic Hinges

Systemcharniere System Hinge



SYSTEMSCHARNIER 40 MIT EINSTELLBARER FRIKTION SYSTEM HINGE 40 WITH ADJUSTABLE FRICTION

Ausführung	mit Abdeckkappen	Model	With cover caps
Beschreibung	für Flächenelemente und Aluminiumprofile, hält Türen und Klappen in jedem Winkel fest; stufenlos einstellbar von 0 - 5 Nm Drehmoment; auch als Aufsteller für leichte Klappen einsetzbar	Description	For panels and aluminum profiles; to hold doors open at any angle; continuously variable from 0 - 5 Nm hinge moment; also supports lightweight horizontal doors
Material	Flügel: Kunststoff PA, glasfaserverstärkt Achse: Edelstahl	Material	Wings: Plastic PA, glass fiber reinforced Axle: Stainless steel
Farbe	schwarz	Color	Black
Befestigung	vorderseitig mit Schrauben M6, rückseitig mit Sechskantmuttern und Schrauben	Fastening	From the front using M6 screws, from the back using hexagon nuts and screws
Liefereinheit	10 Stück	Pack Quantity	10 pieces
Extras	☁ elektrostatisch entladend, weitere Größen, weitere Farben auf Anfrage	Specials	☁ electrostatically discharging, other sizes, other colors on request
Hinweis	Kombinationen unterschiedlicher Flügel auf Anfrage	Tip	Combinations of different wing sizes are available on request

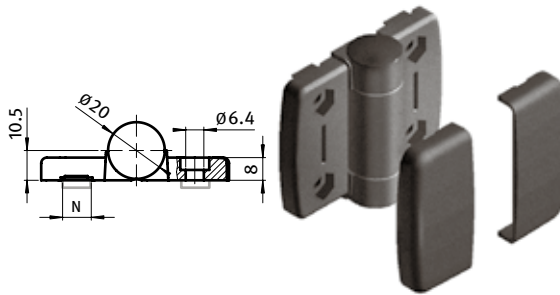
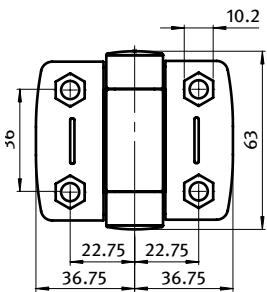

Systemcharniere System Hinge	F _{Amax} [N]	F _{Rmax} [N]	N	Friktionsmoment [Nm] Friction Moment [Nm]	Gewicht [g] Weight [g]	Teil-Nr. Part #
	425	600		0-5	93.0	095SF4040A00
	425	600	8	0-5	93.0	095SF4040A08
	425	600	10	0-5	93.0	095SF4040A10

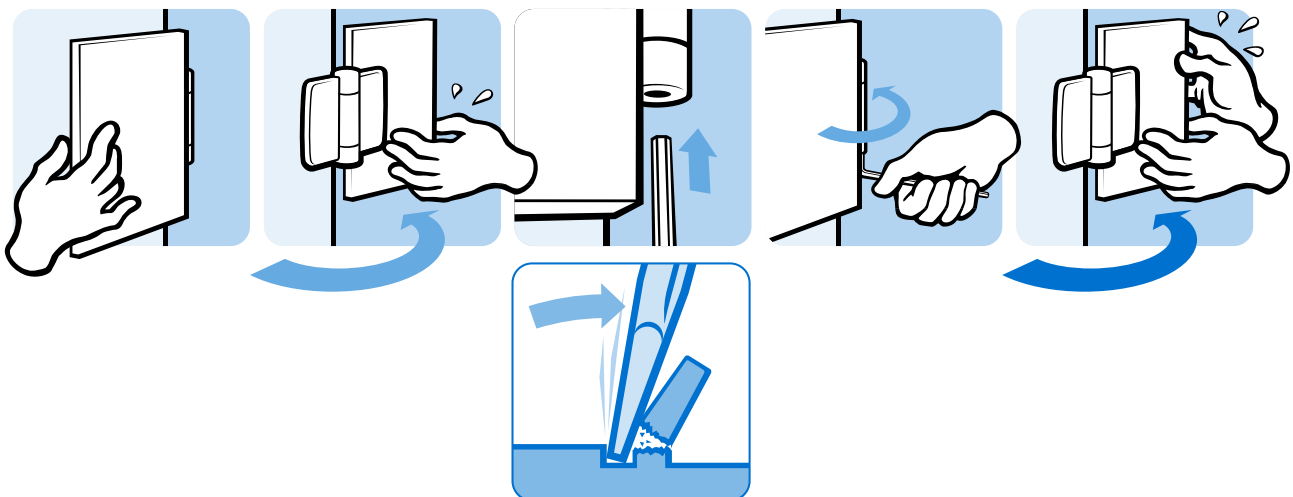



KUNSTSTOFFSCHARNIER 20 MINI

PLASTIC HINGE 20 MINI

Ausführung	nicht aushängbar	Model	Non-detachable
Beschreibung	für Flächenelemente und Aluminiumprofile	Description	To hinge panels or aluminum profiles
Material	Flügel: Kunststoff PA, glasfaserverstärkt Achse: Edelstahl	Material	Wings: Plastic PA, glass fiber reinforced Axle: Stainless steel
Farbe	schwarz	Color	Black
Befestigung	vorderseitig mit Senkschraube M5	Fastening	From the front, using M5 countersunk screws
Liefereinheit	10 Stück	Pack Quantity	10 pieces
Extras	☁ elektrostatisch entladend, weitere Größen, weitere Farben auf Anfrage	Specials	☁ electrostatically discharging, other sizes, other colors on request

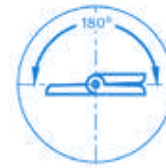
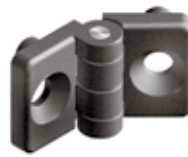
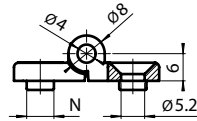
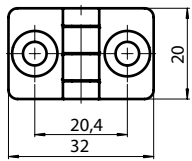

Kunststoffscharnier Plastic Hinge	FMax [N]	FRmax [N]	N	Gewicht [g] Weight [g]	Teil-Nr. Part #
	240	300		5.0	095022F00
	240	300	5	5.0	095022F05
	240	300	6	5.0	095022F06

Scharniere Hinges

Kunststoffscharniere Plastic Hinges



KUNSTSTOFFSCHARNIER LEICHT 35

LIGHT PLASTIC HINGE 35

Ausführung	nicht aushängbar	Model	Non-detachable
Beschreibung	für Flächenelemente und Aluminiumprofile	Description	To hinge panels or aluminum profiles
Material	Flügel: Kunststoff PA, glasfaserverstärkt Achse: Edelstahl	Material	Wings: Plastic PA, glass fiber reinforced Axle: Stainless steel
Farbe	schwarz	Color	Black
Befestigung	vorderseitig mit Linsen- oder Zylinderschrauben M6	Fastening	From the front, using M6 lens or socket head screws
Liefereinheit	10 Stück	Pack Quantity	10 pieces
Extras	⚡ elektrostatisch entladend, weitere Größen, weitere Farben auf Anfrage	Specials	⚡ electrostatically discharging, other sizes, other colors on request

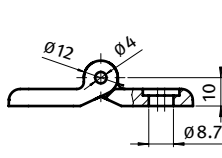
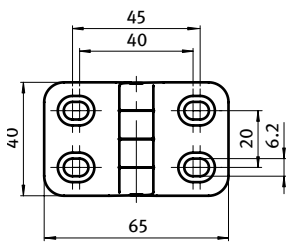

Kunststoffscharnier Plastic Hinge	F _{Amax} [N]	F _{Rmax} [N]	Gewicht [g] Weight [g]	Teil-Nr. Part #
	300	500	7.5	095004

2



KUNSTSTOFFSCHARNIER 32 × 60

PLASTIC HINGE 32 × 60

Ausführung aushängbar
Beschreibung für Aluminiumprofile
Material Flügel: Kunststoff PA, glasfaserverstärkt
 Achse: Edelstahl
Farbe schwarz
Befestigung vorderseitig mit Senkschrauben M6
Liefereinheit 10 Stück
Extras ⚡ elektrostatisch entladend, weitere Größen,
 weitere Farben auf Anfrage

Model Detachable
Description To connect aluminum profiles
Material Wings: Plastic PA, glass fiber reinforced
 Axle: Stainless steel
Color Black
Fastening From the front, using M6 countersunk screws
Pack Quantity 10 pieces
Specials ⚡ electrostatically discharging, other sizes, other
 colors on request

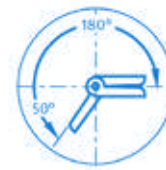
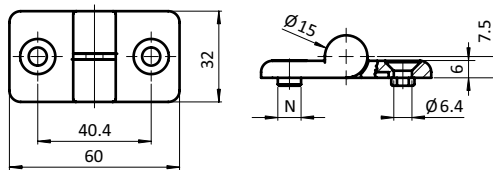

Kunststoffscharnier Plastic Hinge	F _{Max} [N]	F _{Rmax} [N]	N	Gewicht [g] Weight [g]	Teil-Nr. Part #
links left	100	200	8	21.0	095020L
rechts right	100	200	8	21.0	095020R



KUNSTSTOFFSCHARNIER, DOPPELT

PLASTIC HINGE, DOUBLE

Ausführung	aushängbar	Model	Detachable
Beschreibung	für Aluminiumprofile	Description	To connect aluminum profiles
Material	Flügel: Kunststoff PA, glasfaserverstärkt Achse: Edelstahl	Material	Wings: Plastic PA, glass fiber reinforced Axle: Stainless steel
Farbe	schwarz	Color	Black
Befestigung	vorderseitig mit Senkschraube M6	Fastening	From the front, using M6 countersunk screws
Liefereinheit	10 Stück	Pack Quantity	10 pieces
Extras	☞ elektrostatisch entladend, weitere Größen, weitere Farben auf Anfrage	Specials	☞ electrostatically discharging, other sizes, other colors on request

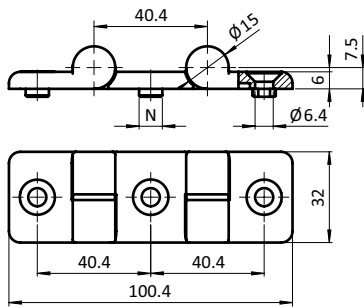

Kunststoffscharnier Plastic Hinge	F _{Amax} [N]	F _{Rmax} [N]	N	Gewicht [g] Weight [g]	Teil-Nr. Part #
	100	200	8	34.0	095020D



KUNSTSTOFFSCHARNIER SCHWER 30

HEAVY-DUTY PLASTIC HINGE 30

Ausführung	nicht aushängbar	Model	Non-detachable
Beschreibung	für Flächenelemente und Aluminiumprofile, mit je zwei Steckplätzen für Zentrierbolzen	Description	To hinge panels or aluminum profiles; each side has two holes for centering bolts
Material	Flügel: Kunststoff PA, glasfaserverstärkt Achse: Edelstahl Montageset: Stahl	Material	Wings: Plastic PA, glass fiber reinforced Axle: Stainless steel Assembly set: Steel
Farbe	Flügel: schwarz	Color	Wings: Black
Befestigung	vorderseitig mit Senkschraube M6	Fastening	From the front, using M6 countersunk screws
Montageset 2	1 Schraube DIN 7991 - M6 × 16, 1 Hammermutter Nut 8 - M6, 1 Schraube DIN 7991 - M6 × 18, 1 Hammermutter Nut 10 - M6	Assembly Set 2	1 screw DIN 7991 - M6 × 16, 1 hammer nut slot 8 - M6, 1 screw DIN 7991 - M6 × 18, 1 hammer nut slot 10 - M6
Liefereinheit	10 Stück	Pack Quantity	10 pieces
Extras	☁ elektrostatisch entladend, weitere Größen, weitere Farben auf Anfrage	Specials	☁ electrostatically discharging, other sizes, other colors on request

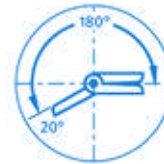
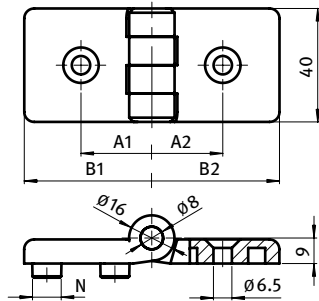

Kunststoffscharnier schwer 30 Heavy-duty Plastic Hinge 30	A1 [mm]	A2 [mm]	B1 [mm]	B2 [mm]	F _{max} [N]	F _{Rmax} [N]	N	Gewicht [g] Weight [g]	Teil-Nr. Part #
30 / 30	17.5	17.5	30.0	30.0	150.0	280.0		36.0	095KS3030F00
	17.5	17.5	30.0	30.0	150.0	280.0	8	37.0	095KS3030F08
30 / 40	17.5	22.5	30.0	39.0	150.0	280.0		38.0	095KS3040F00
	17.5	22.5	30.0	39.0	150.0	280.0	8	39.0	095KS3040F08
	17.5	22.5	30.0	39.0	150.0	280.0	8 / 10	39.0	095KS3040F0810
30 / 45	17.5	25.0	30.0	45.0	150.0	280.0		39.0	095KS3045F00
	17.5	25.0	30.0	45.0	150.0	280.0	8 / 10	40.0	095KS3045F0810
30 / 60	17.5	32.5	30.0	60.0	130.0	280.0		43.0	095KS3060F00
	17.5	32.5	30.0	60.0	130.0	280.0	8 / 10	44.0	095KS3060F0810
30 / 40 inkl. Montageset 2 30 / 40 With assembly set 2	17.5	22.5	30.0	39.0	150.0	280.0	8 / 10	44.0	095KS3040F0810S01
30 / 45 inkl. Montageset 2 30 / 45 With assembly set 2	17.5	25.0	30.0	45.0	150.0	280.0	8 / 10	45.0	095KS3045F0810S02
30 / 60 inkl. Montageset 2 30 / 60 With assembly set 2	17.5	32.5	30.0	60.0	130.0	280.0	8 / 10	49.0	095KS3060F0810S01

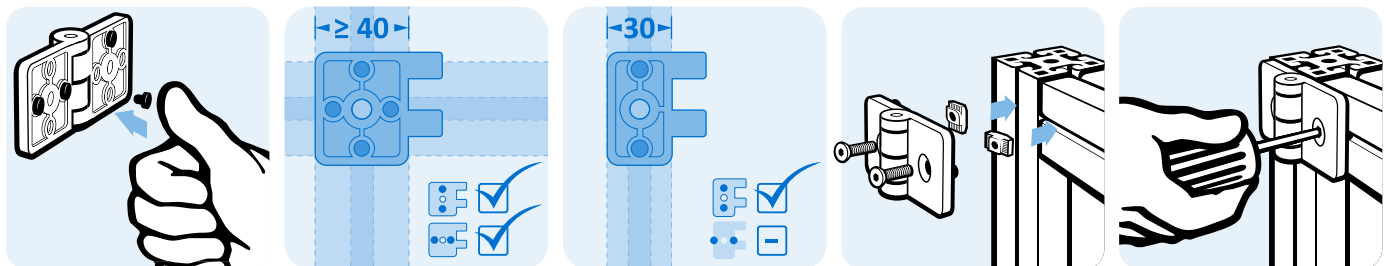



KUNSTSTOFFSCHARNIER SCHWER 40

HEAVY-DUTY PLASTIC HINGE 40

Ausführung	nicht aushängbar	Model	Non-detachable
Beschreibung	für Flächenelemente und Aluminiumprofile, mit je zwei Steckplätzen für Zentrierbolzen	Description	To hinge panels or aluminum profiles; each side has two holes for centering bolts
Material	Flügel: Kunststoff PA, glasfaserverstärkt Achse: Edelstahl Montageset: Stahl	Material	Wings: Plastic PA, glass fiber reinforced Axle: Stainless steel Assembly set: Steel
Farbe	Flügel: schwarz	Color	Wings: Black
Befestigung	vorderseitig mit Senkschraube M6	Fastening	From the front, using M6 countersunk screws
Montageset 3	2 Schrauben DIN 7991 - M6 × 18, 2 Hammermüttern Nut 10 - M6	Assembly Set 3	2 screws DIN 7991 - M6 × 18, 2 hammer nuts slot 10 - M6
Liefereinheit	10 Stück	Pack Quantity	10 pieces
Extras	⚡ elektrostatisch entladend, weitere Größen, weitere Farben auf Anfrage	Specials	⚡ electrostatically discharging, other sizes, other colors on request

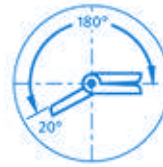
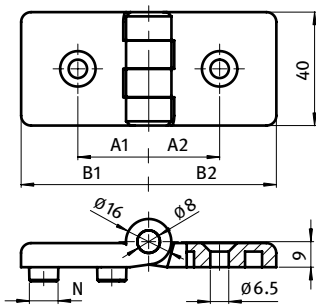

Kunststoffscharnier schwer 40 Heavy-duty Plastic Hinge 40	A1 [mm]	A2 [mm]	B1 [mm]	B2 [mm]	F _{Amax} [N]	F _{Rmax} [N]	N	Gewicht [g] Weight [g]	Teil-Nr. Part #
40 / 40	22.5	22.5	39.0	39.0	150.0	280.0		40.0	095KS4040F00
	22.5	22.5	39.0	39.0	150.0	280.0	8	42.0	095KS4040F08
	22.5	22.5	39.0	39.0	150.0	280.0	8 / 10	43.0	095KS4040F0810
	22.5	22.5	39.0	39.0	150.0	280.0	10	45.0	095KS4040F10
40 / 45	22.5	25.0	39.0	45.0	150.0	280.0		41.0	095KS4045F00
	22.5	25.0	39.0	45.0	150.0	280.0	8 / 10	43.0	095KS4045F0810
	22.5	25.0	39.0	45.0	150.0	280.0	10	45.0	095KS4045F10
40 / 60	22.5	32.5	39.0	60.0	130.0	280.0		45.0	095KS4060F00
	22.5	32.5	39.0	60.0	130.0	280.0	8 / 10	48.0	095KS4060F0810
	22.5	32.5	39.0	60.0	130.0	280.0	10	49.0	095KS4060F10
40 / 40 inkl. Montageset 3 40 / 40 With assembly set 3	22.5	22.5	39.0	39.0	150.0	280.0	10	50.0	095KS4040F10S01

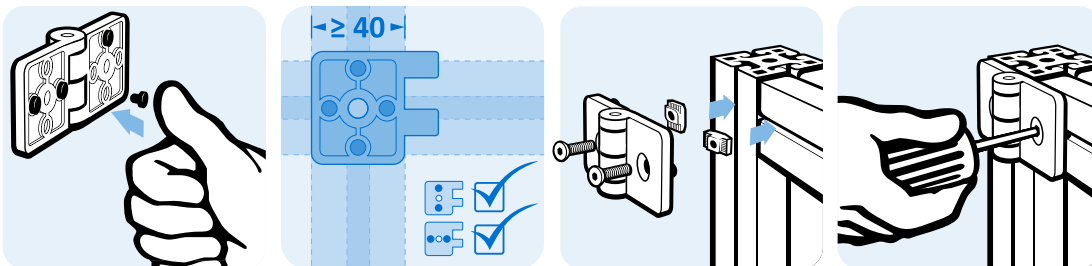



KUNSTSTOFFSCHARNIER SCHWER 45

HEAVY-DUTY PLASTIC HINGE 45

Ausführung	nicht aushängbar	Model	Non-detachable
Beschreibung	für Flächenelemente und Aluminiumprofile, mit je zwei Steckplätzen für Zentrierbolzen	Description	To hinge panels or aluminum profiles; each side has two holes for centering bolts
Material	Flügel: Kunststoff PA, glasfaserverstärkt Achse: Edelstahl Montageset: Stahl	Material	Wings: Plastic PA, glass fiber reinforced Axle: Stainless steel Assembly set: Steel
Farbe	Flügel: schwarz	Color	Wings: Black
Befestigung	vorderseitig mit Senkschraube M6	Fastening	From the front, using M6 countersunk screws
Montageset 3	2 Schrauben DIN 7991 - M6 × 18, 2 Hammermuttern Nut 10 - M6	Assembly Set 3	2 screws DIN 7991 - M6 × 18, 2 hammer nuts slot 10 - M6
Liefereinheit	10 Stück	Pack Quantity	10 pieces
Extras	⚡ elektrostatisch entladend, weitere Größen, weitere Farben auf Anfrage	Specials	⚡ electrostatically discharging, other sizes, other colors on request

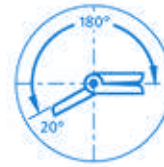
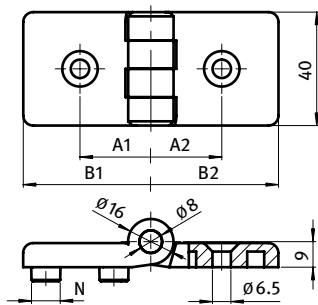

Kunststoffscharnier schwer 45 Heavy-duty Plastic Hinge 45	A1 [mm]	A2 [mm]	B1 [mm]	B2 [mm]	F _{Amax} [N]	F _{Rmax} [N]	N	Gewicht [g] Weight [g]	Teil-Nr. Part #
45 / 45	25.0	25.0	45.0	45.0	150.0	280.0		44.0	095KS4545F00
	25.0	25.0	45.0	45.0	150.0	280.0	10	46.0	095KS4545F10
45 / 60	25.0	32.5	45.0	60.0	130.0	280.0		47.0	095KS4560F00
	25.0	32.5	45.0	60.0	130.0	280.0	10	50.0	095KS4560F10
45 / 45 inkl. Montageset 3 45 / 45 With assembly set 3	25.0	25.0	45.0	45.0	150.0	280.0	10	51.0	095KS4545F10S03
45 / 60 inkl. Montageset 3 45 / 60 With assembly set 3	25.0	32.5	45.0	60.0	130.0	280.0	10	55.0	095KS4560F10S01

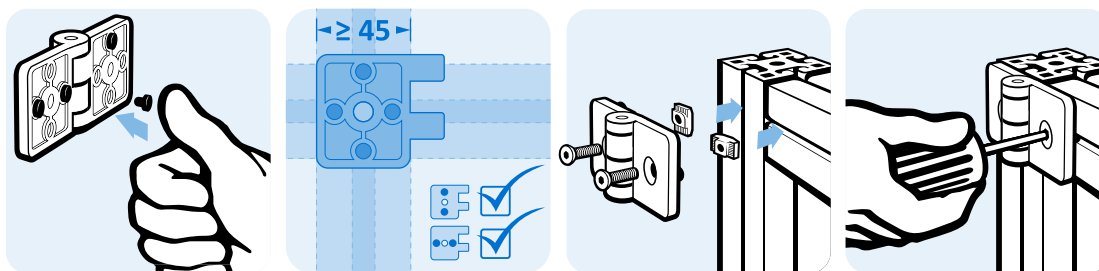

Scharniere Hinges

Kunststoffscharniere Plastic Hinges



KUNSTSTOFFSCHARNIER SCHWER 60

HEAVY-DUTY PLASTIC HINGE 60

Ausführung	nicht aushängbar	Model	Non-detachable
Beschreibung	für Flächenelemente und Aluminiumprofile, mit je zwei Steckplätzen für Zentrierbolzen	Description	To hinge panels or aluminum profiles; each side has two holes for centering bolts
Material	Flügel: Kunststoff PA, glasfaserverstärkt Achse: Edelstahl Montageset: Stahl	Material	Wings: Plastic PA, glass fiber reinforced Axle: Stainless steel Assembly set: Steel
Farbe	Flügel: schwarz	Color	Wings: Black
Befestigung	vorderseitig mit Senkschraube M6	Fastening	From the front, using M6 countersunk screws
Montageset 3	2 Schrauben DIN 7991 - M6 × 18, 2 Hammermüttern Nut 10 - M6	Assembly Set 3	2 screws DIN 7991 - M6 × 18, 2 hammer nuts slot 10 - M6
Liefereinheit	10 Stück	Pack Quantity	10 pieces
Extras	⚡ elektrostatisch entladend, weitere Größen, weitere Farben auf Anfrage	Specials	⚡ electrostatically discharging, other sizes, other colors on request

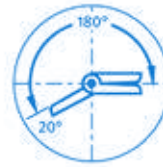
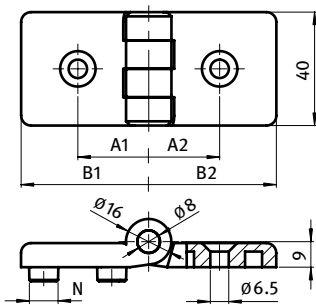

Kunststoffscharnier schwer 60 Heavy-duty Plastic Hinge 60	A1 [mm]	A2 [mm]	B1 [mm]	B2 [mm]	F _{Amax} [N]	F _{Rmax} [N]	N	Gewicht [g] Weight [g]	Teil-Nr. Part #
60 / 60	32.5	32.5	60.0	60.0	130.0	280.0		51.0	095KS6060F00
	32.5	32.5	60.0	60.0	130.0	280.0	10	53.0	095KS6060F10
60 / 60 inkl. Montageset 3 60 / 60 With assembly set 3	32.5	32.5	60.0	60.0	130.0	280.0	10	58.0	095KS6060F10S01

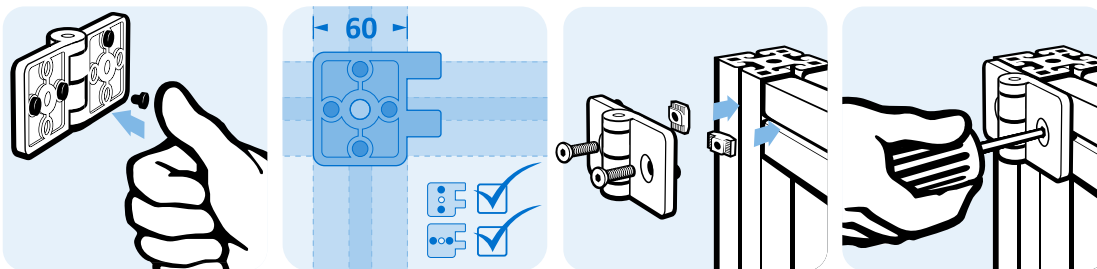

Scharniere Hinges

Kunststoffscharniere Plastic Hinges



KUNSTSTOFFSCHARNIER SCHWER 65 × 64

HEAVY-DUTY PLASTIC HINGE 65 × 64

Ausführung	nicht aushängbar	Model	Non-detachable
Beschreibung	für Flächenelemente und Aluminiumprofile	Description	To hinge panels or aluminum profiles
Material	Flügel: Kunststoff PA, glasfaserverstärkt Achse: Edelstahl	Material	Wings: Plastic PA, glass fiber reinforced Axle: Stainless steel
Farbe	schwarz	Color	Black
Befestigung	vorderseitig mit Senkschrauben M6	Fastening	From the front, using M6 countersunk screws
Liefereinheit	100 Stück	Pack Quantity	100 pieces
Extras	☞ elektrostatisch entladend, weitere Größen, weitere Farben auf Anfrage	Specials	☞ electrostatically discharging, other sizes, other colors on request

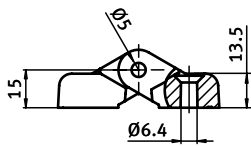
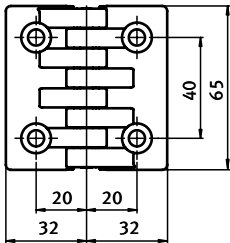

Kunststoffscharnier Plastic Hinge	F _{Amax} [N]	F _{Rmax} [N]	Gewicht [g] Weight [g]	Teil-Nr. Part #
	150.0	280.0	62.0	095065

Scharniere Hinges

Aluminiumdruckgusscharniere Aluminum Die-cast Hinges

Kombischarniere Combi Hinges



ALUDRUCKGUSS-KOMBISCHARNIER 25

ALUMINUM DIE-CAST COMBI HINGE 25

Ausführung	aushängbar	Model	Detachable
Beschreibung	für Flächenelemente und Aluminiumprofile, pro Scharnierflügel je ein Steckplatz für Zentrierbolzen, Scharnierachse in Buchsensystem gelagert	Description	To hinge panels or aluminum profiles, each wing with a hole for centering bolts, with bearing system for axle
Material	Flügel: Aluminiumdruckguss Achse: Edelstahl Buchsen: PTFE Zentrierbolzen (optional): Kunststoff PA, glasfaserverstärkt	Material	Wings: Die-cast aluminum Axle: Stainless steel Bearings: PTFE Centering bolts (optional): Plastic PA, glass fiber reinforced
Farbe	Zentrierbolzen (optional): schwarz	Color	Centering bolts (optional): Black
Befestigung	vorderseitig mit Senkschrauben M6	Fastening	From the front, using M6 countersunk screws
Liefereinheit	10 Stück	Pack Quantity	10 pieces

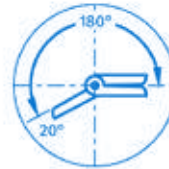
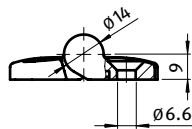
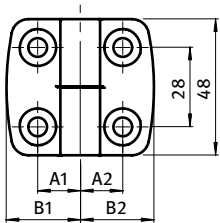

Kombischarnier Combi Hinge	A1 [mm]	A2 [mm]	B1 [mm]	B2 [mm]	F _{Amax} [N]	F _{Rmax} [N]	Bezeichnung Description	Gewicht [g] Weight [g]	Teil-Nr. Part #
L: links <i>Left</i>	15.0	15.0	26.0	26.0	250	410	25/25	56.0	095A2525LS20
	15.0	17.5	26.0	29.5	280	450	25/30	60.0	095A2530LS20
	15.0	20.0	26.0	36.0	250	500	25/35	64.0	095A2535LS20
	15.0	22.5	26.0	38.5	200	550	25/40	62.0	095A2540LS20
	15.0	25.0	26.0	43.5	200	550	25/45	64.0	095A2545LS20
	15.0	27.5	26.0	48.5	175	575	25/50	67.0	095A2550LS20
	15.0	32.5	26.0	57.5	150	575	25/60	72.0	095A2560LS20
R: rechts <i>Right</i>	15.0	15.0	26.0	26.0	250	410	25/25	56.0	095A2525RS20
	17.5	15.0	29.5	26.0	280	450	25/30	60.0	095A2530RS20
	20.0	15.0	36.0	26.0	250	500	25/35	64.0	095A2535RS20
	22.5	15.0	38.5	26.0	200	550	25/40	62.0	095A2540RS20
	25.0	15.0	43.5	26.0	200	550	25/45	64.0	095A2545RS20
	27.5	15.0	48.5	26.0	175	575	25/50	67.0	095A2550RS20
	32.5	15.0	57.5	26.0	150	575	25/60	72.0	095A2560RS20
Zentrierbolzen Centering bolt							Nut 5 Slot 5	1.0	095AN05
							Nut 6 Slot 6	1.0	095AN06
							Nut 8 Slot 8	1.0	095AN08
							Nut 10 Slot 10	1.0	095AN10
							Nut 12 Slot 12	1.0	095AN12
							Nut 14 Slot 14	1.0	095AN14

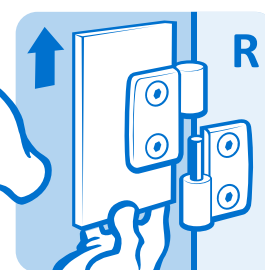
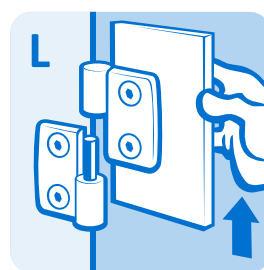
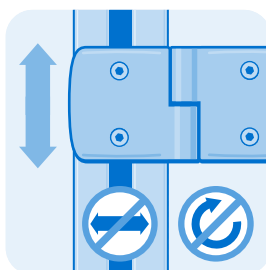
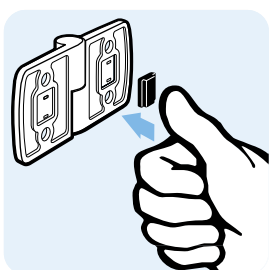

Scharniere Hinges

Aluminiumdruckgusscharniere Aluminum Die-cast Hinges
Kombischarniere Combi Hinges



ALUDRUCKGUSS-KOMBISCHARNIER 25

ALUMINUM DIE-CAST COMBI HINGE 25

Ausführung	nicht aushängbar	Model	Non-detachable
Beschreibung	für Flächenelemente und Aluminiumprofile, pro Scharnierflügel je ein Steckplatz für Zentrierbolzen, Scharnierachse in Buchsensystem gelagert	Description	To hinge panels or aluminum profiles, each wing with a hole for centering bolts, with bearing system for axle
Material	Flügel: Aluminiumdruckguss Achse: Edelstahl Buchsen: PTFE Zentrierbolzen (optional): Kunststoff PA, glasfaserverstärkt	Material	Wings: Die-cast aluminum Axle: Stainless steel Bearings: PTFE Centering bolts (optional): Plastic PA, glass fiber reinforced
Farbe	Zentrierbolzen (optional): schwarz	Color	Centering bolts (optional): Black
Befestigung	vorderseitig mit Senkschrauben M6	Fastening	From the front, using M6 countersunk screws
Liefereinheit	10 Stück	Pack Quantity	10 pieces

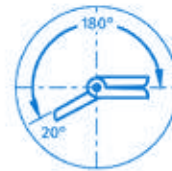
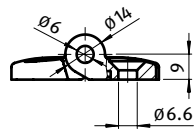
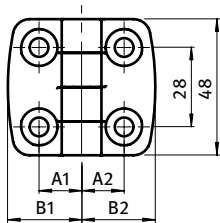

Kombischarnier Combi Hinge	A1 [mm]	A2 [mm]	B1 [mm]	B2 [mm]	F _{Amax} [N]	F _{Rmax} [N]	Bezeichnung Description	Gewicht [g] Weight [g]	Teil-Nr. Part #
nicht aushängbar Non-detachable	15.0	15.0	26.0	26.0	215	275	25/25	57.0	095A2525FS20
	15.0	17.5	26.0	29.5	225	325	25/30	61.0	095A2530FS20
	15.0	20.0	26.0	36.0	225	325	25/35	65.0	095A2535FS20
	15.0	22.5	26.0	38.5	250	400	25/40	63.0	095A2540FS20
	15.0	25.0	26.0	43.5	250	400	25/45	65.0	095A2545FS20
	15.0	27.5	26.0	48.5	250	400	25/50	68.0	095A2550FS20
	15.0	32.5	26.0	57.5	100	400	25/60	73.0	095A2560FS20
Zentrierbolzen Centering bolt							Nut 5 Slot 5	1.0	095AN05
							Nut 6 Slot 6	1.0	095AN06
							Nut 8 Slot 8	1.0	095AN08
							Nut 10 Slot 10	1.0	095AN10
							Nut 12 Slot 12	1.0	095AN12
							Nut 14 Slot 14	1.0	095AN14

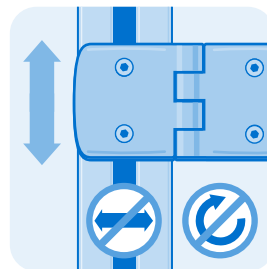

Scharniere Hinges

Aluminiumdruckgusscharniere Aluminum Die-cast Hinges

Kombischarniere Combi Hinges



ALUDRUCKGUSS-KOMBISCHARNIER 30

ALUMINUM DIE-CAST COMBI HINGE 30

Ausführung	aushängbar	Model	Detachable
Beschreibung	für Flächenelemente und Aluminiumprofile, pro Scharnierflügel je ein Steckplatz für Zentrierbolzen, Scharnierachse in Buchsensystem gelagert	Description	To hinge panels or aluminum profiles, each wing with a hole for centering bolts, with bearing system for axle
Material	Flügel: Aluminiumdruckguss Achse: Edelstahl Buchsen: PTFE Zentrierbolzen (optional): Kunststoff PA, glasfaserverstärkt	Material	Wings: Die-cast aluminum Axle: Stainless steel Bearings: PTFE Centering bolts (optional): Plastic PA, glass fiber reinforced
Farbe	Zentrierbolzen (optional): schwarz	Color	Centering bolts (optional): Black
Befestigung	vorderseitig mit Senkschrauben M6	Fastening	From the front, using M6 countersunk screws
Liefereinheit	10 Stück	Pack Quantity	10 pieces

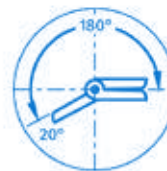
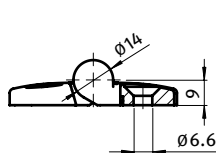
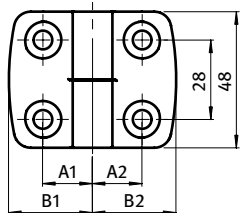

Kombischarnier Combi Hinge	A1 [mm]	A2 [mm]	B1 [mm]	B2 [mm]	FAMax [N]	FRmax [N]	Bezeichnung Description	Gewicht [g] Weight [g]	Teil-Nr. Part #
L: links <i>Left</i>	17.5	17.5	29.5	29.5	280	450	30/30	64.0	095A3030LS20
	17.5	15.0	29.5	26.0	250	410	30/25	60.0	095A3025LS20
	17.5	20.0	29.5	36.0	250	500	30/35	68.0	095A3035LS20
	17.5	22.5	29.5	38.5	200	550	30/40	66.0	095A3040LS20
	17.5	25.0	29.5	43.5	200	550	30/45	68.0	095A3045LS20
	17.5	27.5	29.5	48.5	175	575	30/50	71.0	095A3050LS20
	17.5	32.5	29.5	57.5	150	575	30/60	76.0	095A3060LS20
R: rechts <i>Right</i>	17.5	17.5	29.5	29.5	280	450	30/30	64.0	095A3030RS20
	15.0	17.5	26.0	29.5	250	410	30/25	60.0	095A3025RS20
	20.0	17.5	36.0	29.5	250	500	30/35	68.0	095A3035RS20
	22.5	17.5	38.5	29.5	200	550	30/40	66.0	095A3040RS20
	25.0	17.5	43.5	29.5	200	550	30/45	68.0	095A3045RS20
	27.5	17.5	48.5	29.5	175	575	30/50	71.0	095A3050RS20
	32.5	17.5	57.5	29.5	150	575	30/60	76.0	095A3060RS20
Zentrierbolzen Centering bolt							Nut 5 Slot 5	1.0	095AN05
							Nut 6 Slot 6	1.0	095AN06
							Nut 8 Slot 8	1.0	095AN08
							Nut 10 Slot 10	1.0	095AN10
							Nut 12 Slot 12	1.0	095AN12
							Nut 14 Slot 14	1.0	095AN14

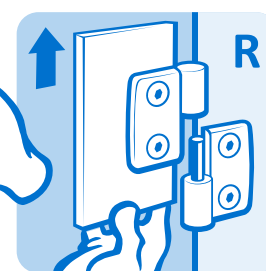
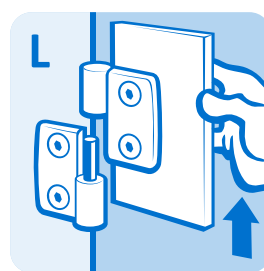
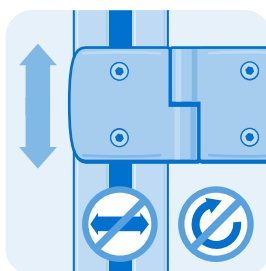
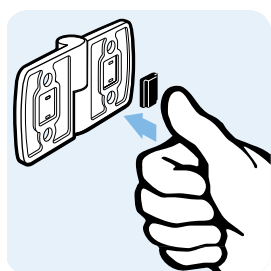

Scharniere Hinges

Aluminiumdruckgusscharniere Aluminum Die-cast Hinges
Kombischarniere Combi Hinges



ALUDRUCKGUSS-KOMBISCHARNIER 30

ALUMINUM DIE-CAST COMBI HINGE 30

Ausführung	nicht aushängbar	Model	Non-detachable
Beschreibung	für Flächenelemente und Aluminiumprofile, pro Scharnierflügel je ein Steckplatz für Zentrierbolzen, Scharnierachse in Buchsensystem gelagert	Description	To hinge panels or aluminum profiles, each wing with a hole for centering bolts, with bearing system for axle
Material	Flügel: Aluminiumdruckguss Achse: Edelstahl Buchsen: PTFE Zentrierbolzen (optional): Kunststoff PA, glasfaserverstärkt	Material	Wings: Die-cast aluminum Axle: Stainless steel Bearings: PTFE Centering bolts (optional): Plastic PA, glass fiber reinforced
Farbe	Zentrierbolzen (optional): schwarz	Color	Centering bolts (optional): Black
Befestigung	vorderseitig mit Senkschrauben M6	Fastening	From the front, using M6 countersunk screws
Liefereinheit	10 Stück	Pack Quantity	10 pieces

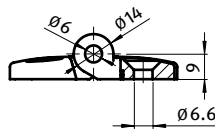
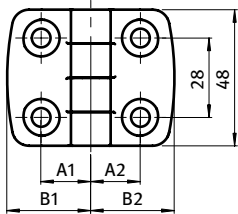

Kombischarnier Combi Hinge	A1 [mm]	A2 [mm]	B1 [mm]	B2 [mm]	F _{Amax} [N]	F _{Rmax} [N]	Bezeichnung Description	Gewicht [g] Weight [g]	Teil-Nr. Part #
nicht aushängbar Non-detachable	17.5	17.5	29.5	29.5	225	325	30/30	65.0	095A3030FS20
	17.5	20.0	29.5	36.0	225	325	30/35	69.0	095A3035FS20
	17.5	22.5	29.5	38.5	250	400	30/40	67.0	095A3040FS20
	17.5	25.0	29.5	43.5	250	400	30/45	69.0	095A3045FS20
	17.5	27.5	29.5	48.5	250	400	30/50	72.0	095A3050FS20
	17.5	32.5	29.5	57.5	100	400	30/60	77.0	095A3060FS20
Zentrierbolzen Centering bolt							Nut 5 Slot 5	1.0	095AN05
							Nut 6 Slot 6	1.0	095AN06
							Nut 8 Slot 8	1.0	095AN08
							Nut 10 Slot 10	1.0	095AN10
							Nut 12 Slot 12	1.0	095AN12
							Nut 14 Slot 14	1.0	095AN14

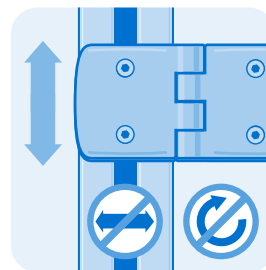

Scharniere Hinges

Aluminiumdruckgusscharniere Aluminum Die-cast Hinges

Kombischarniere Combi Hinges



ALUDRUCKGUSS-KOMBISCHARNIER 35

ALUMINUM DIE-CAST COMBI HINGE 35

Ausführung	aushängbar	Model	Detachable
Beschreibung	für Flächenelemente und Aluminiumprofile, pro Scharnierflügel je ein Steckplatz für Zentrierbolzen, Scharnierachse in Buchsensystem gelagert	Description	To hinge panels or aluminum profiles, each wing with a hole for centering bolts, with bearing system for axle
Material	Flügel: Aluminiumdruckguss Achse: Edelstahl Buchsen: PTFE Zentrierbolzen (optional): Kunststoff PA, glasfaserverstärkt	Material	Wings: Die-cast aluminum Axle: Stainless steel Bearings: PTFE Centering bolts (optional): Plastic PA, glass fiber reinforced
Farbe	Zentrierbolzen (optional): schwarz	Color	Centering bolts (optional): Black
Befestigung	vorderseitig mit Senkschrauben M6	Fastening	From the front, using M6 countersunk screws
Liefereinheit	10 Stück	Pack Quantity	10 pieces

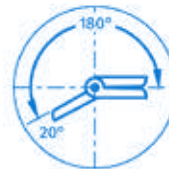
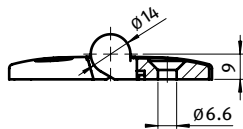
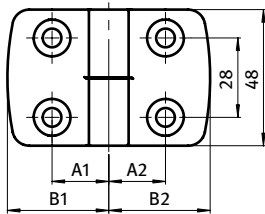

Kombischarnier Combi Hinge	A1 [mm]	A2 [mm]	B1 [mm]	B2 [mm]	F _{Amax} [N]	F _{Rmax} [N]	Bezeichnung Description	Gewicht [g] Weight [g]	Teil-Nr. Part #
L: links <i>Left</i>	20.0	20.0	36.0	36.0	250	500	35/35	72.0	095A3535LS20
	20.0	15.0	36.0	26.0	250	410	35/25	64.0	095A3525LS20
	20.0	17.5	36.0	29.5	280	450	35/30	68.0	095A3530LS20
	20.0	22.5	36.0	38.5	200	550	35/40	70.0	095A3540LS20
	20.0	25.0	36.0	43.5	200	550	35/45	72.0	095A3545LS20
	20.0	27.5	36.0	48.5	175	575	35/50	75.0	095A3550LS20
	20.0	32.5	36.0	57.5	150	575	35/60	80.0	095A3560LS20
R: rechts <i>Right</i>	20.0	20.0	36.0	36.0	250	500	35/35	72.0	095A3535RS20
	15.0	20.0	26.0	36.0	250	410	35/25	64.0	095A3525RS20
	17.5	20.0	29.5	36.0	280	450	35/30	68.0	095A3530RS20
	22.5	20.0	38.5	36.0	200	550	35/40	70.0	095A3540RS20
	25.0	20.0	43.5	36.0	200	550	35/45	72.0	095A3545RS20
	27.5	20.0	48.5	36.0	175	575	35/50	75.0	095A3550RS20
	32.5	20.0	57.5	36.0	150	575	35/60	80.0	095A3560RS20
Zentrierbolzen Centering bolt							Nut 5 Slot 5	1.0	095AN05
							Nut 6 Slot 6	1.0	095AN06
							Nut 8 Slot 8	1.0	095AN08
							Nut 10 Slot 10	1.0	095AN10
							Nut 12 Slot 12	1.0	095AN12
							Nut 14 Slot 14	1.0	095AN14

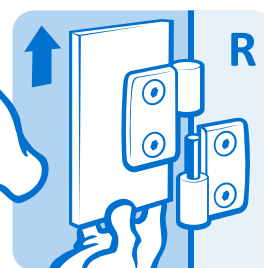
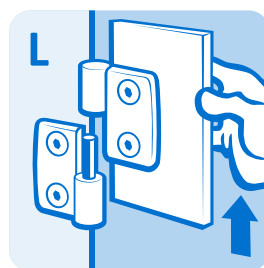
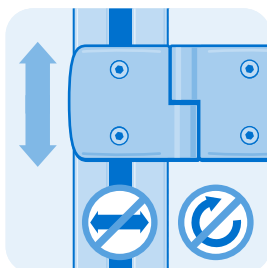
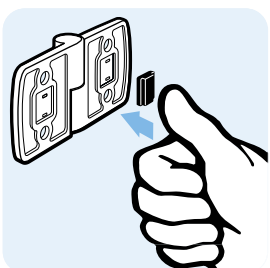

Scharniere Hinges

Aluminiumdruckgusscharniere Aluminum Die-cast Hinges

Kombischarniere Combi Hinges



ALUDRUCKGUSS-KOMBISCHARNIER 35

ALUMINUM DIE-CAST COMBI HINGE 35

Ausführung	nicht aushängbar	Model	Non-detachable
Beschreibung	für Flächenelemente und Aluminiumprofile, pro Scharnierflügel je ein Steckplatz für Zentrierbolzen, Scharnierachse in Buchsensystem gelagert	Description	To hinge panels or aluminum profiles, each wing with a hole for centering bolts, with bearing system for axle
Material	Flügel: Aluminiumdruckguss Achse: Edelstahl Buchsen: PTFE Zentrierbolzen (optional): Kunststoff PA, glasfaserverstärkt	Material	Wings: Die-cast aluminum Axle: Stainless steel Bearings: PTFE Centering bolts (optional): Plastic PA, glass fiber reinforced
Farbe	Zentrierbolzen (optional): schwarz	Color	Centering bolts (optional): Black
Befestigung	vorderseitig mit Senkschrauben M6	Fastening	From the front, using M6 countersunk screws
Liefereinheit	10 Stück	Pack Quantity	10 pieces

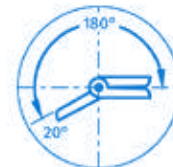
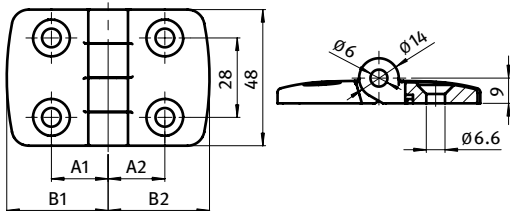

Kombischarnier Combi Hinge	A1 [mm]	A2 [mm]	B1 [mm]	B2 [mm]	F _{Amax} [N]	F _{Rmax} [N]	Bezeichnung Description	Gewicht [g] Weight [g]	Teil-Nr. Part #
nicht aushängbar Non-detachable	20.0	20.0	36.0	36.0	225	325	35/35	73.0	095A3535FS20
	20.0	22.5	36.0	38.5	250	400	35/40	71.0	095A3540FS20
	20.0	25.0	36.0	43.5	250	400	35/45	73.0	095A3545FS20
	20.0	27.5	36.0	48.5	250	400	35/50	76.0	095A3550FS20
	20.0	32.5	36.0	57.5	100	400	35/60	81.0	095A3560FS20
Zentrierbolzen Centering bolt							Nut 5 Slot 5	1.0	095AN05
							Nut 6 Slot 6	1.0	095AN06
							Nut 8 Slot 8	1.0	095AN08
							Nut 10 Slot 10	1.0	095AN10
							Nut 12 Slot 12	1.0	095AN12
						Nut 14 Slot 14	1.0	095AN14	

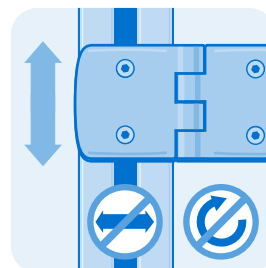

Scharniere Hinges

Aluminiumdruckgusscharniere Aluminum Die-cast Hinges

Kombischarniere Combi Hinges



ALUDRUCKGUSS-KOMBISCHARNIER 40

ALUMINUM DIE-CAST COMBI HINGE 40

Ausführung	aushängbar	Model	Detachable
Beschreibung	für Flächenelemente und Aluminiumprofile, pro Scharnierflügel je ein Steckplatz für Zentrierbolzen, Scharnierachse in Buchsensystem gelagert	Description	To hinge panels or aluminum profiles, each wing with a hole for centering bolts, with bearing system for axle
Material	Flügel: Aluminiumdruckguss Achse: Edelstahl Buchsen: PTFE Zentrierbolzen (optional): Kunststoff PA, glasfaser-verstärkt	Material	Wings: Die-cast aluminum Axle: Stainless steel Bearings: PTFE Centering bolts (optional): Plastic PA, glass fiber reinforced
Farbe	Zentrierbolzen (optional): schwarz	Color	Centering bolts (optional): Black
Befestigung	vorderseitig mit Senkschrauben M6	Fastening	From the front, using M6 countersunk screws
Liefereinheit	10 Stück	Pack Quantity	10 pieces

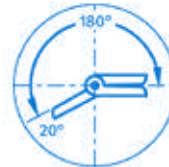
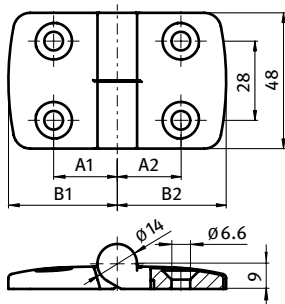

Kombischarnier Combi Hinge	A1 [mm]	A2 [mm]	B1 [mm]	B2 [mm]	F _{Amax} [N]	F _{Rmax} [N]	Bezeichnung Description	Gewicht [g] Weight [g]	Teil-Nr. Part #
L: links <i>Left</i>	22.5	22.5	38.5	38.5	200	550	40/40	68.0	095A4040LS20
	22.5	15.0	38.5	26.0	250	410	40/25	62.0	095A4025LS20
	22.5	17.5	38.5	29.5	280	450	40/30	66.0	095A4030LS20
	22.5	20.0	38.5	36.0	250	500	40/35	70.0	095A4035LS20
	22.5	25.0	38.5	43.5	200	550	40/45	70.0	095A4045LS20
	22.5	27.5	38.5	48.5	175	575	40/50	73.0	095A4050LS20
	22.5	32.5	38.5	57.5	150	575	40/60	78.0	095A4060LS20
R: rechts <i>Right</i>	22.5	22.5	38.5	38.5	200	550	40/40	68.0	095A4040RS20
	15.0	22.5	26.0	38.5	250	410	40/25	62.0	095A4025RS20
	17.5	22.5	29.5	38.5	280	450	40/30	66.0	095A4030RS20
	20.0	22.5	36.0	38.5	250	500	40/35	70.0	095A4035RS20
	25.0	22.5	43.5	38.5	200	550	40/45	70.0	095A4045RS20
	27.5	22.5	48.5	38.5	175	575	40/50	73.0	095A4050RS20
	32.5	22.5	57.5	38.5	150	575	40/60	78.0	095A4060RS20
Zentrierbolzen Centering bolt							Nut 5 Slot 5	1.0	095AN05
							Nut 6 Slot 6	1.0	095AN06
							Nut 8 Slot 8	1.0	095AN08
							Nut 10 Slot 10	1.0	095AN10
							Nut 12 Slot 12	1.0	095AN12
							Nut 14 Slot 14	1.0	095AN14

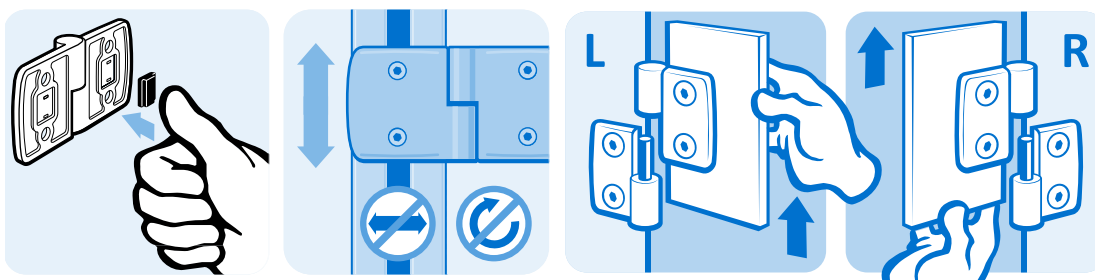

Scharniere Hinges

Aluminiumdruckgusscharniere Aluminum Die-cast Hinges
Kombischarniere Combi Hinges



ALUDRUCKGUSS-KOMBISCHARNIER 40

ALUMINUM DIE-CAST COMBI HINGE 40

Ausführung	nicht aushängbar	Model	Non-detachable
Beschreibung	für Flächenelemente und Aluminiumprofile, pro Scharnierflügel je ein Steckplatz für Zentrierbolzen, Scharnierachse in Buchsensystem gelagert	Description	To hinge panels or aluminum profiles, each wing with a hole for centering bolts, with bearing system for axle
Material	Flügel: Aluminiumdruckguss Achse: Edelstahl Buchsen: PTFE Zentrierbolzen (optional): Kunststoff PA, glasfaser-verstärkt	Material	Wings: Die-cast aluminum Axle: Stainless steel Bearings: PTFE Centering bolts (optional): Plastic PA, glass fiber reinforced
Farbe	Zentrierbolzen (optional): schwarz	Color	Centering bolts (optional): Black
Befestigung	vorderseitig mit Senkschrauben M6	Fastening	From the front, using M6 countersunk screws
Liefereinheit	10 Stück	Pack Quantity	10 pieces

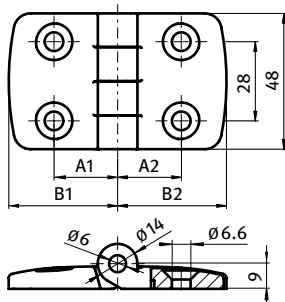

Kombischarnier Combi Hinge	A1 [mm]	A2 [mm]	B1 [mm]	B2 [mm]	F _{Amax} [N]	F _{Rmax} [N]	Bezeichnung Description	Gewicht [g] Weight [g]	Teil-Nr. Part #
nicht aushängbar Non-detachable	22.5	22.5	38.5	38.5	250	400	40/40	69.0	095A4040FS20
	22.5	25.0	38.5	43.5	250	400	40/45	71.0	095A4045FS20
	22.5	27.5	38.5	48.5	250	400	40/50	74.0	095A4050FS20
	22.5	32.5	38.5	57.5	100	400	40/60	79.0	095A4060FS20
Zentrierbolzen Centering bolt							Nut 5 Slot 5	1.0	095AN05
							Nut 6 Slot 6	1.0	095AN06
							Nut 8 Slot 8	1.0	095AN08
							Nut 10 Slot 10	1.0	095AN10
							Nut 12 Slot 12	1.0	095AN12
						Nut 14 Slot 14	1.0	095AN14	

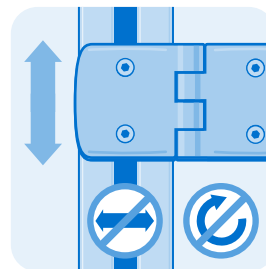

Scharniere Hinges

Aluminiumdruckgusscharniere Aluminum Die-cast Hinges

Kombischarniere Combi Hinges



ALUDRUCKGUSS-KOMBISCHARNIER 45

ALUMINUM DIE-CAST COMBI HINGE 45

Ausführung	aushängbar	Model	Detachable
Beschreibung	für Flächenelemente und Aluminiumprofile, pro Scharnierflügel je ein Steckplatz für Zentrierbolzen, Scharnierachse in Buchsensystem gelagert	Description	To hinge panels or aluminum profiles, each wing with a hole for centering bolts, with bearing system for axle
Material	Flügel: Aluminiumdruckguss Achse: Edelstahl Buchsen: PTFE Zentrierbolzen (optional): Kunststoff PA, glasfaser-verstärkt	Material	Wings: Die-cast aluminum Axle: Stainless steel Bearings: PTFE Centering bolts (optional): Plastic PA, glass fiber reinforced
Farbe	Zentrierbolzen (optional): schwarz	Color	Centering bolts (optional): Black
Befestigung	vorderseitig mit Senkschrauben M6	Fastening	From the front, using M6 countersunk screws
Liefereinheit	10 Stück	Pack Quantity	10 pieces

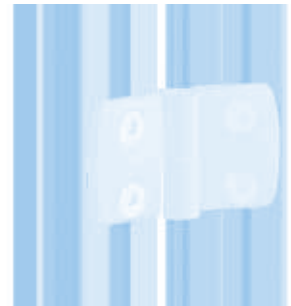
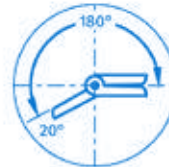
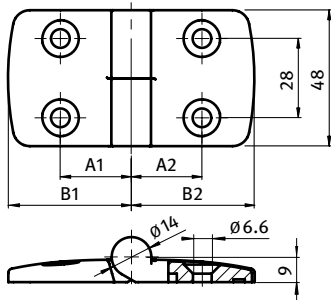

Kombischarnier Combi Hinge	A1 [mm]	A2 [mm]	B1 [mm]	B2 [mm]	F _{Amax} [N]	F _{Rmax} [N]	Bezeichnung Description	Gewicht [g] Weight [g]	Teil-Nr. Part #
L: links <i>Left</i>	25.0	25.0	43.5	43.5	200	550	45/45	70.0	095A4545LS20
	25.0	15.0	43.5	26.0	250	410	45/25	64.0	095A4525LS20
	25.0	17.5	43.5	29.5	280	450	45/30	68.0	095A4530LS20
	25.0	20.0	43.5	36.0	250	500	45/35	72.0	095A4535LS20
	25.0	22.5	43.5	38.5	200	550	45/40	70.0	095A4540LS20
	25.0	27.5	43.5	48.5	175	575	45/50	75.0	095A4550LS20
	25.0	32.5	43.5	57.5	150	575	45/60	80.0	095A4560LS20
R: rechts <i>Right</i>	25.0	25.0	43.5	43.5	200	550	45/45	70.0	095A4545RS20
	15.0	25.0	26.0	43.5	250	410	45/25	64.0	095A4525RS20
	17.5	25.0	29.5	43.5	280	450	45/30	68.0	095A4530RS20
	20.0	25.0	36.0	43.5	250	500	45/35	72.0	095A4535RS20
	22.5	25.0	38.5	43.5	200	550	45/40	70.0	095A4540RS20
	27.5	25.0	48.5	43.5	175	575	45/50	75.0	095A4550RS20
	32.5	25.0	57.5	43.5	150	575	45/60	80.0	095A4560RS20
Zentrierbolzen Centering bolt							Nut 5 Slot 5	1.0	095AN05
							Nut 6 Slot 6	1.0	095AN06
							Nut 8 Slot 8	1.0	095AN08
							Nut 10 Slot 10	1.0	095AN10
							Nut 12 Slot 12	1.0	095AN12
						Nut 14 Slot 14	1.0	095AN14	

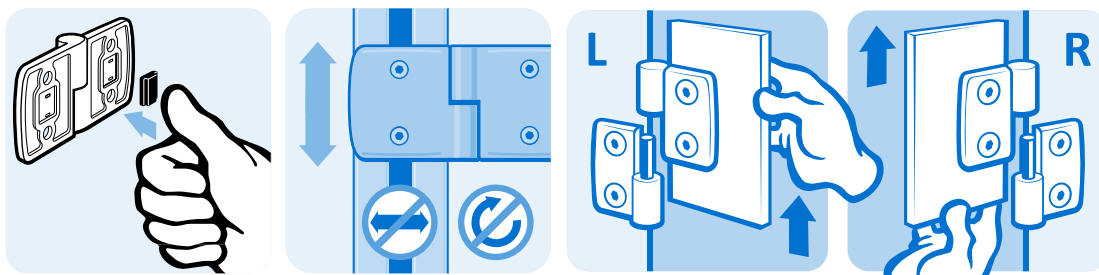

Scharniere Hinges

Aluminiumdruckgusscharniere Aluminum Die-cast Hinges
Kombischarniere Combi Hinges



ALUDRUCKGUSS-KOMBISCHARNIER 45

ALUMINUM DIE-CAST COMBI HINGE 45

Ausführung	nicht aushängbar	Model	Non-detachable
Beschreibung	für Flächenelemente und Aluminiumprofile, pro Scharnierflügel je ein Steckplatz für Zentrierbolzen, Scharnierachse in Buchsensystem gelagert	Description	To hinge panels or aluminum profiles, each wing with a hole for centering bolts, with bearing system for axle
Material	Flügel: Aluminiumdruckguss Achse: Edelstahl Buchsen: PTFE Zentrierbolzen (optional): Kunststoff PA, glasfaserverstärkt	Material	Wings: Die-cast aluminum Axle: Stainless steel Bearings: PTFE Centering bolts (optional): Plastic PA, glass fiber reinforced
Farbe	Zentrierbolzen (optional): schwarz	Color	Centering bolts (optional): Black
Befestigung	vorderseitig mit Senkschrauben M6	Fastening	From the front, using M6 countersunk screws
Liefereinheit	10 Stück	Pack Quantity	10 pieces

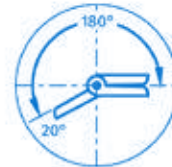
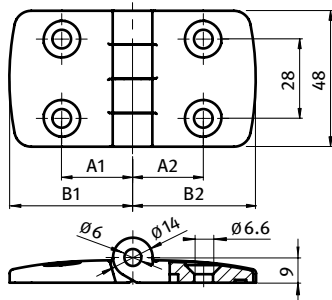

Kombischarnier Combi Hinge	A1 [mm]	A2 [mm]	B1 [mm]	B2 [mm]	F _{Amax} [N]	F _{Rmax} [N]	Bezeichnung Description	Gewicht [g] Weight [g]	Teil-Nr. Part #
nicht aushängbar Non-detachable	25.0	25.0	43.5	43.5	250	400	45/45	73.0	095A4545FS20
	25.0	27.5	43.5	48.5	250	400	45/50	76.0	095A4550FS20
	25.0	32.5	43.5	57.5	100	400	45/60	81.0	095A4560FS20
Zentrierbolzen Centering bolt							Nut 5 Slot 5	1.0	095AN05
							Nut 6 Slot 6	1.0	095AN06
							Nut 8 Slot 8	1.0	095AN08
							Nut 10 Slot 10	1.0	095AN10
							Nut 12 Slot 12	1.0	095AN12
							Nut 14 Slot 14	1.0	095AN14

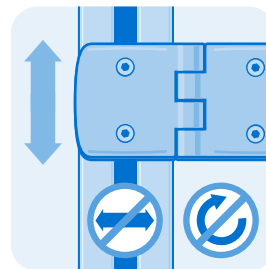

Scharniere Hinges

Aluminiumdruckgusscharniere Aluminum Die-cast Hinges

Kombischarniere Combi Hinges



ALUDRUCKGUSS-KOMBISCHARNIER 50

ALUMINUM DIE-CAST COMBI HINGE 50

Ausführung	aushängbar	Model	Detachable
Beschreibung	für Flächenelemente und Aluminiumprofile, pro Scharnierflügel je ein Steckplatz für Zentrierbolzen, Scharnierachse in Buchsensystem gelagert	Description	To hinge panels or aluminum profiles, each wing with a hole for centering bolts, with bearing system for axle
Material	Flügel: Aluminiumdruckguss Achse: Edelstahl Buchsen: PTFE Zentrierbolzen (optional): Kunststoff PA, glasfaser-verstärkt	Material	Wings: Die-cast aluminum Axle: Stainless steel Bearings: PTFE Centering bolts (optional): Plastic PA, glass fiber reinforced
Farbe	Zentrierbolzen (optional): schwarz	Color	Centering bolts (optional): Black
Befestigung	vorderseitig mit Senkschrauben M6	Fastening	From the front, using M6 countersunk screws
Liefereinheit	10 Stück	Pack Quantity	10 pieces

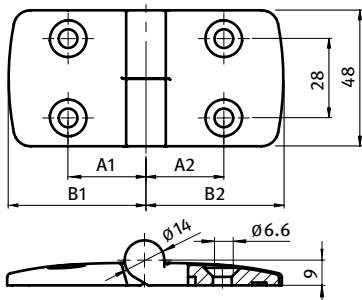

Kombischarnier Combi Hinge	A1 [mm]	A2 [mm]	B1 [mm]	B2 [mm]	F _{Amax} [N]	F _{Rmax} [N]	Bezeichnung Description	Gewicht [g] Weight [g]	Teil-Nr. Part #
L: links Left	27.5	27.5	48.5	48.5	175	550	50/50	78.0	095A5050LS20
	27.5	15.0	48.5	26.0	250	410	50/25	67.0	095A5025LS20
	27.5	17.5	48.5	29.5	280	450	50/30	71.0	095A5030LS20
	27.5	20.0	48.5	36.0	250	500	50/35	75.0	095A5035LS20
	27.5	22.5	48.5	38.5	200	550	50/40	73.0	095A5040LS20
	27.5	25.0	48.5	43.5	200	550	50/45	75.0	095A5045LS20
	27.5	32.5	48.5	57.5	150	550	50/60	83.0	095A5060LS20
R: rechts Right	27.5	27.5	48.5	48.5	175	500	50/50	78.0	095A5050RS20
	15.0	27.5	26.0	48.5	250	410	50/25	67.0	095A5025RS20
	17.5	27.5	29.5	48.5	250	410	50/30	71.0	095A5030RS20
	20.0	27.5	36.0	48.5	250	500	50/35	75.0	095A5035RS20
	22.5	27.5	38.5	48.5	200	550	50/40	73.0	095A5040RS20
	25.0	27.5	43.5	48.5	200	550	50/45	75.0	095A5045RS20
	32.5	27.5	57.5	48.5	150	550	50/60	83.0	095A5060RS20
Zentrierbolzen Centering bolt							Nut 5 Slot 5	1.0	095AN05
							Nut 6 Slot 6	1.0	095AN06
							Nut 8 Slot 8	1.0	095AN08
							Nut 10 Slot 10	1.0	095AN10
							Nut 12 Slot 12	1.0	095AN12
							Nut 14 Slot 14	1.0	095AN14

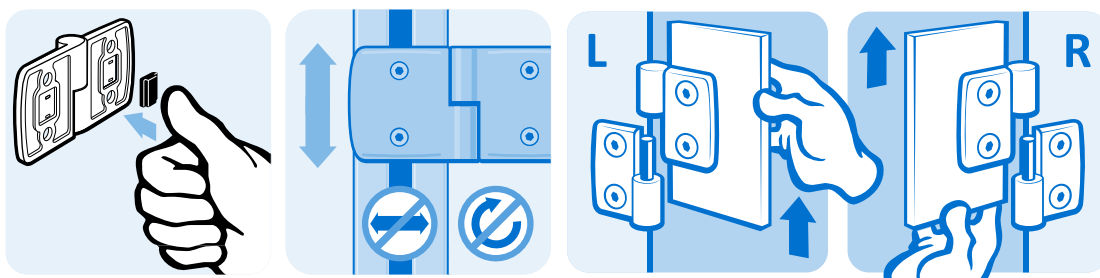

Scharniere Hinges

Aluminiumdruckgusscharniere Aluminum Die-cast Hinges
Kombischarniere Combi Hinges



ALUDRUCKGUSS-KOMBISCHARNIER 50

ALUMINUM DIE-CAST COMBI HINGE 50

Ausführung	nicht aushängbar	Model	Non-detachable
Beschreibung	für Flächenelemente und Aluminiumprofile, pro Scharnierflügel je ein Steckplatz für Zentrierbolzen, Scharnierachse in Buchsensystem gelagert	Description	To hinge panels or aluminum profiles, each wing with a hole for centering bolts, with bearing system for axle
Material	Flügel: Aluminiumdruckguss Achse: Edelstahl Buchsen: PTFE Zentrierbolzen (optional): Kunststoff PA, glasfaser-verstärkt	Material	Wings: Die-cast aluminum Axle: Stainless steel Bearings: PTFE Centering bolts (optional): Plastic PA, glass fiber reinforced
Farbe	Zentrierbolzen (optional): schwarz	Color	Centering bolts (optional): Black
Befestigung	vorderseitig mit Senkschrauben M6	Fastening	From the front, using M6 countersunk screws
Liefereinheit	10 Stück	Pack Quantity	10 pieces

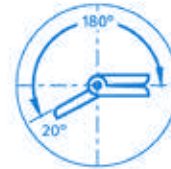
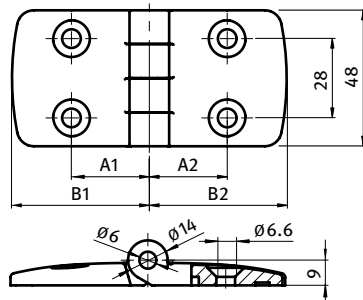

Kombischarnier Combi Hinge	A1 [mm]	A2 [mm]	B1 [mm]	B2 [mm]	F _{Amax} [N]	F _{Rmax} [N]	Bezeichnung Description	Gewicht [g] Weight [g]	Teil-Nr. Part #
nicht aushängbar Non-detachable	27.5	27.5	48.5	48.5	250	400	50/50	79.0	095A5050FS20
	27.5	32.5	48.5	57.5	250	400	50/60	84.0	095A5060FS20
Zentrierbolzen Centering bolt							Nut 5 Slot 5	1.0	095AN05
							Nut 6 Slot 6	1.0	095AN06
							Nut 8 Slot 8	1.0	095AN08
							Nut 10 Slot 10	1.0	095AN10
							Nut 12 Slot 12	1.0	095AN12
							Nut 14 Slot 14	1.0	095AN14

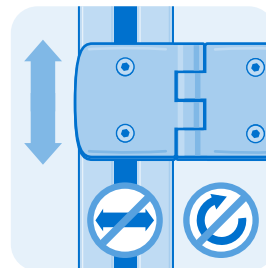

Scharniere Hinges

Aluminiumdruckgusscharniere Aluminum Die-cast Hinges

Kombischarniere Combi Hinges



ALUDRUCKGUSS-KOMBISCHARNIER 60

ALUMINUM DIE-CAST COMBI HINGE 60

Ausführung	aushängbar	Model	Detachable
Beschreibung	für Flächenelemente und Aluminiumprofile, pro Scharnierflügel je ein Steckplatz für Zentrierbolzen, Scharnierachse in Buchsensystem gelagert	Description	To hinge panels or aluminum profiles, each wing with a hole for centering bolts, with bearing system for axle
Material	Flügel: Aluminiumdruckguss Achse: Edelstahl Buchsen: PTFE Zentrierbolzen (optional): Kunststoff PA, glasfaserverstärkt	Material	Wings: Die-cast aluminum Axle: Stainless steel Bearings: PTFE Centering bolts (optional): Plastic PA, glass fiber reinforced
Farbe	Zentrierbolzen (optional): schwarz	Color	Centering bolts (optional): Black
Befestigung	vorderseitig mit Senkschrauben M6	Fastening	From the front, using M6 countersunk screws
Liefereinheit	10 Stück	Pack Quantity	10 pieces

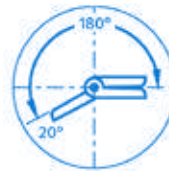
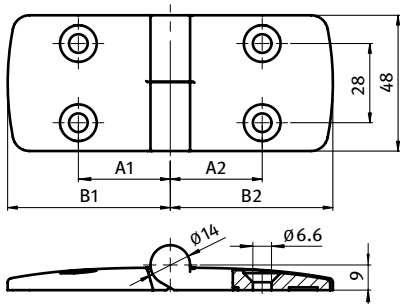

Kombischarnier Combi Hinge	A1 [mm]	A2 [mm]	B1 [mm]	B2 [mm]	F _{Amax} [N]	F _{Rmax} [N]	Bezeichnung Description	Gewicht [g] Weight [g]	Teil-Nr. Part #
L: links Left	32.5	32.5	57.5	57.5	150	575	60/60	88.0	095A6060LS20
	32.5	15.0	57.5	26.0	250	410	60/25	72.0	095A6025LS20
	32.5	17.5	57.5	29.5	280	450	60/30	76.0	095A6030LS20
	32.5	20.0	57.5	36.0	250	500	60/35	80.0	095A6035LS20
	32.5	22.5	57.5	38.5	200	550	60/40	78.0	095A6040LS20
	32.5	25.0	57.5	43.5	200	550	60/45	80.0	095A6045LS20
	32.5	27.5	57.5	48.5	175	575	60/50	83.0	095A6050LS20
R: rechts Right	32.5	32.5	57.5	57.5	150	575	60/60	88.0	095A6060RS20
	15.0	32.5	26.0	57.5	250	410	60/25	72.0	095A6025RS20
	17.5	32.5	29.5	57.5	280	450	60/30	76.0	095A6030RS20
	20.0	32.5	36.0	57.5	250	500	60/35	80.0	095A6035RS20
	22.5	32.5	38.5	57.5	200	550	60/40	78.0	095A6040RS20
	25.0	32.5	43.5	57.5	200	550	60/45	80.0	095A6045RS20
	27.5	32.5	48.5	57.5	175	575	60/50	83.0	095A6050RS20
Zentrierbolzen Centering bolt							Nut 5 Slot 5	1.0	095AN05
							Nut 6 Slot 6	1.0	095AN06
							Nut 8 Slot 8	1.0	095AN08
							Nut 10 Slot 10	1.0	095AN10
							Nut 12 Slot 12	1.0	095AN12
							Nut 14 Slot 14	1.0	095AN14

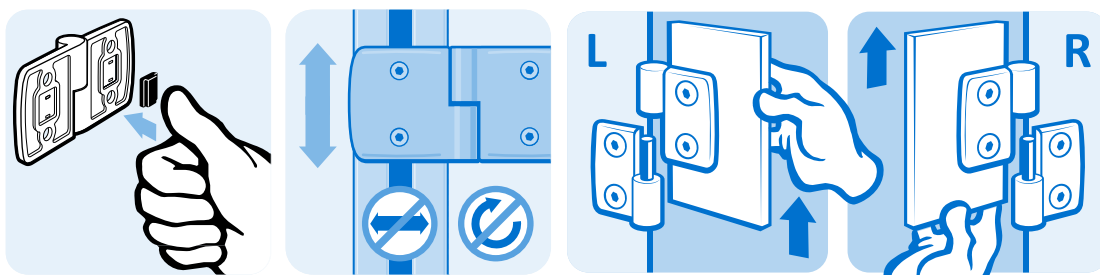

Scharniere Hinges

Aluminiumdruckgusscharniere Aluminum Die-cast Hinges
Kombischarniere Combi Hinges



ALUDRUCKGUSS-KOMBISCHARNIER 60

ALUMINUM DIE-CAST COMBI HINGE 60

Ausführung	nicht aushängbar	Model	Non-detachable
Beschreibung	für Flächenelemente und Aluminiumprofile, pro Scharnierflügel je ein Steckplatz für Zentrierbolzen, Scharnierachse in Buchsensystem gelagert	Description	To hinge panels or aluminum profiles, each wing with a hole for centering bolts, with bearing system for axle
Material	Flügel: Aluminiumdruckguss Achse: Edelstahl Buchsen: PTFE Zentrierbolzen (optional): Kunststoff PA, glasfaserverstärkt	Material	Wings: Die-cast aluminum Axle: Stainless steel Bearings: PTFE Centering bolts (optional): Plastic PA, glass fiber reinforced
Farbe	Zentrierbolzen (optional): schwarz	Color	Centering bolts (optional): Black
Befestigung	vorderseitig mit Senkschrauben M6	Fastening	From the front, using M6 countersunk screws
Liefereinheit	10 Stück	Pack Quantity	10 pieces

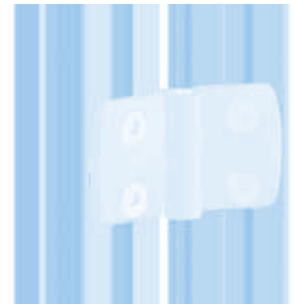
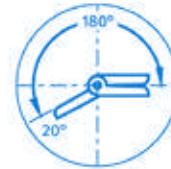
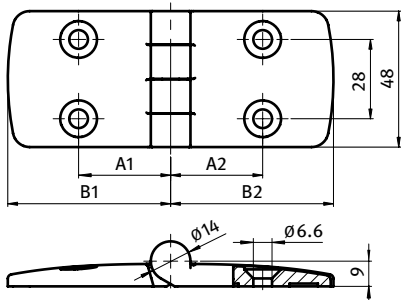

Kombischarnier Combi Hinge	A1 [mm]	A2 [mm]	B1 [mm]	B2 [mm]	F _{Amax} [N]	F _{Rmax} [N]	Bezeichnung Description	Gewicht [g] Weight [g]	Teil-Nr. Part #
nicht aushängbar Non-detachable	32.5	32.5	57.5	57.5	100	400	60/60	89.0	095A6060FS20
Zentrierbolzen Centering bolt							Nut 5 Slot 5	1.0	095AN05
							Nut 6 Slot 6	1.0	095AN06
							Nut 8 Slot 8	1.0	095AN08
							Nut 10 Slot 10	1.0	095AN10
							Nut 12 Slot 12	1.0	095AN12
							Nut 14 Slot 14	1.0	095AN14

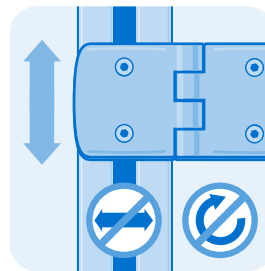



ALUDRUCKGUSS-SCHARNIER

ALUMINUM DIE-CAST HINGE

Ausführung	nicht aushängbar	Model	Non-detachable
Beschreibung	für Flächenelemente und Aluminiumprofile	Description	To hinge panels or aluminum profiles
Material	Flügel: Aluminiumdruckguss Achse: Edelstahl	Material	Wings: Aluminum die-cast Axle: Stainless steel
Befestigung	vorderseitig mit Senkschraube M6	Fastening	From the front, using M6 countersunk screws
Liefereinheit	10 Stück	Pack Quantity	10 pieces
Extras	weitere Oberflächen, weitere Farben auf Anfrage	Specials	Other surfaces, other colors on request

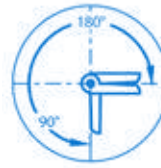
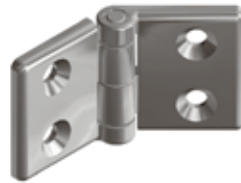
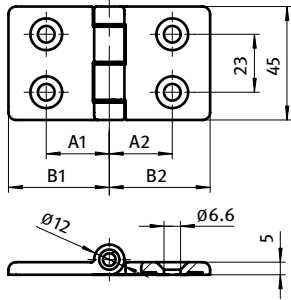

Aludruckguss-Scharnier Aluminum die-cast Hinge	A1 [mm]	A2 [mm]	B1 [mm]	B2 [mm]	FMax [N]	FRmax [N]	Gewicht [g] Weight [g]	Teil-Nr. Part #
	25.0	25.0	40.0	40.0	200	350	56.0	095047



SCHWERLASTSCHARNIER

HEAVY-DUTY HINGE

Ausführung	nicht aushängbar	Model	Non-detachable
Beschreibung	für Flächenelemente und Aluminiumprofile, Scharnierachse in Buchsensystem gelagert	Description	For panels and aluminum profiles, with bearing system for axle
Material	Flügel: Aluminiumdruckguss Achse: Edelstahl Buchsen: PTFE	Material	Wing: Aluminum die-cast Axle: Stainless steel Bearings: PTFE
Befestigung	vorderseitig mit Zylinderschrauben DIN 7984 - M6 oder Linsenkopfschrauben ISO 7380 - M6	Fastening	From the front, using socket head screws DIN 7984 - M6 or pan-head screws ISO 7380 - M6
Liefereinheit	10 Stück	Pack Quantity	10 pieces

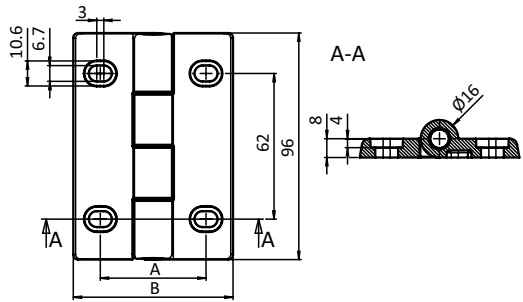

Schwerlastscharnier Heavy-duty Hinge	A [mm]	B [mm]	Gewicht [g] Weight [g]	Teil-Nr. Part #
30 / 30	35.0	58.0	137.3	095050
40 / 40	45.0	68.0	155.0	095051
45 / 45	50.0	78.0	169.5	095052

Scharniere Hinges

Aluminium Scharniere Aluminum Hinges



SET ALU-SCHARNIER, SCHWER

SET HEAVY ALUMINUM HINGE

<p>Ausführung aushängbar, justierbar</p> <p>Beschreibung belastbares, aushängbares Scharnier; justierbar zum Ausgleich von Abstandstoleranzen</p> <p>Material Flügel: Aluminium Achse: Edelstahl</p> <p>Befestigung vorderseitig mit je zwei Sechskant- und zwei Senkschrauben M8</p> <p>Set 1 Alu-Scharnier schwer, 2 Nutensteine Nut 10 - M8 – mit Führungssteg, 2 Sechskantschrauben DIN 6921 - M8 × 16, 2 Senkschrauben DIN 7991 - M8 × 12, 2 Nutensteine Nut 8 - M8 – mit Führungssteg</p> <p>Liefereinheit 2 Stück</p>	<p>Model Detachable, adjustable</p> <p>Description Loadable detachable hinge; adjustable for the compensation of distance tolerances</p> <p>Material Wings: Aluminum die-cast Axle: Stainless steel</p> <p>Fastening From the front, using two hexagon and two countersunk screws M8</p> <p>Set 1 heavy aluminum hinge, 2 T-slot nuts, slot 10 - M8 – self-aligning, 2 hexagon screws DIN 6921 - M8 × 16, 2 countersunk screws DIN 7991 - M8 × 12, 2 T-slot nuts, slot 8 - M8 – self-aligning</p> <p>Pack Quantity 2 pieces</p>
--	---

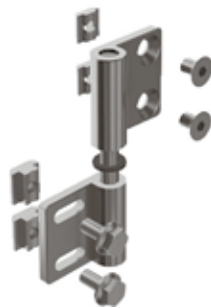
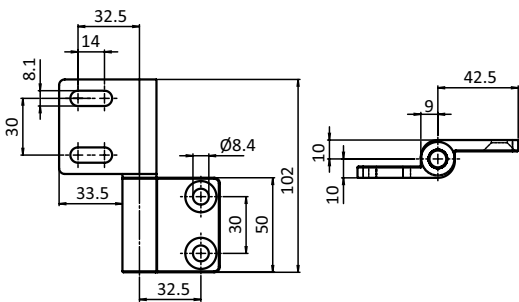

Set Alu-Scharnier, schwer
Set Heavy Aluminum Hinge

Gewicht [g]
Weight [g]

Profil
Profile

Teil-Nr.
Part #

262.7

B

095071

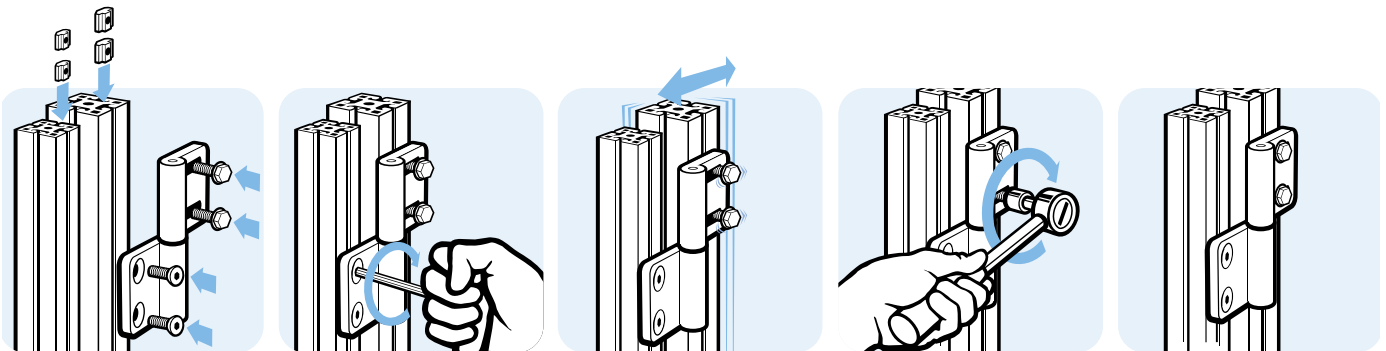



ALUMINIUM-SCHARNIER 40 LEICHT

ALUMINUM HINGE 40 LIGHT

Ausführung	aushängbar, Nut 8	Model	Detachable, slot 8
Beschreibung	für Flächenelemente und Aluminiumprofile; links oder rechts zusammensteckbar	Description	For panels and aluminum profiles; left or right side assembly
Material	Flügel: Aluminium Achse: Edelstahl Abdeckkappe: Kunststoff PA, glasfaserverstärkt	Material	Wings: Aluminum Axle: Stainless steel Cover cap: Plastic PA, glass fiber reinforced
Farbe	Abdeckkappe: weißaluminium ≈RAL 9006	Color	Cover cap: White aluminum ≈RAL 9006
Befestigung	vorderseitig mit Senkschrauben M6	Fastening	From the front, using M6 countersunk screws
Montageset	2 Senkschrauben DIN 7991 - M6 × 14, 2 Nutensteine M6 - Nut 8 - mit Führungssteg	Assembly Set	2 countersunk screws DIN 7991 - M6 × 14, 2 self-aligning T-Slot nuts M6 - slot 8
Liefereinheit	10 Stück	Pack Quantity	10 pieces



Aluminium-Scharnier 40 leicht Aluminum Hinge 40 Light	A1 [mm]	A2 [mm]	B1 [mm]	B2 [mm]	N	Gewicht [g] Weight [g]	Profil Profile	Teil-Nr. Part #
	43.0	43.0	27.5	27.5	8	84.0		095AL40N0840N08
inkl. Montageset With assembly set	43.0	43.0	27.5	27.5	8	106.0	I	095AL40N0840N08S01

2

Scharniere Hinges

Aluminium Scharniere Aluminum Hinges
Scharnier-Elemente Hinge Component



INNENLIEGENDES SCHARNIER-ELEMENT

CONCEALED HINGE COMPONENT

Ausführung	Aluminium, eloxiert	Model	Aluminum, anodized
Beschreibung	für Flächenelemente und Aluminiumprofile, zur individuellen Zusammenstellung von innenliegenden Scharnieren	Description	For panels and aluminum profiles, for individual assembly of concealed hinges
Material	Flügel: Aluminium Achse: Edelstahl Abdeckkappe: PA, glasfaserverstärkt	Material	Wing: Aluminum Axle: Stainless steel Cover cap: PA, glass fibre reinforced
Befestigung	vorderseitig mit Senkschrauben	Fastening	From the front, using countersunk screws
Liefereinheit	10 Stück	Pack Quantity	10 pieces

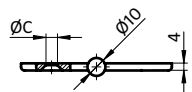
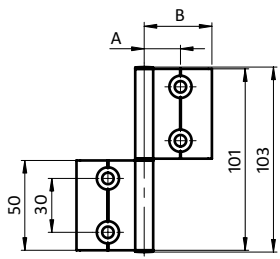

Innenliegendes Scharnier Internal Hinge	A [mm]	B [mm]	C [mm]	F _{Amax} [N]	F _{Rmax} [N]	Gewicht [g] Weight [g]	Teil-Nr. Part #
20	14.5	22.0	Ø 5.3	150	100	15.0	095AI20
25	17.5	28.0	Ø 6.4	150	100	18.0	095AI25
30	19.5	32.0	Ø 6.4	150	100	20.0	095AI30
38	21.1	40.1	Ø 6.4	150	100	24.0	095AI38
40	25.0	42.0	Ø 6.4	150	100	25.3	095AI40
45	27.0	47.0	Ø 6.4	150	100	28.0	095AI45
50	29.5	52.0	Ø 6.4	150	100	30.7	095AI50
60	34.5	62.0	Ø 6.4	150	100	36.0	095AI60
Achse Axle						12.0	095AIR01
Abdeckkappe Cover cap						0.15	095AIA

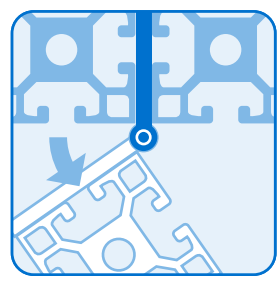
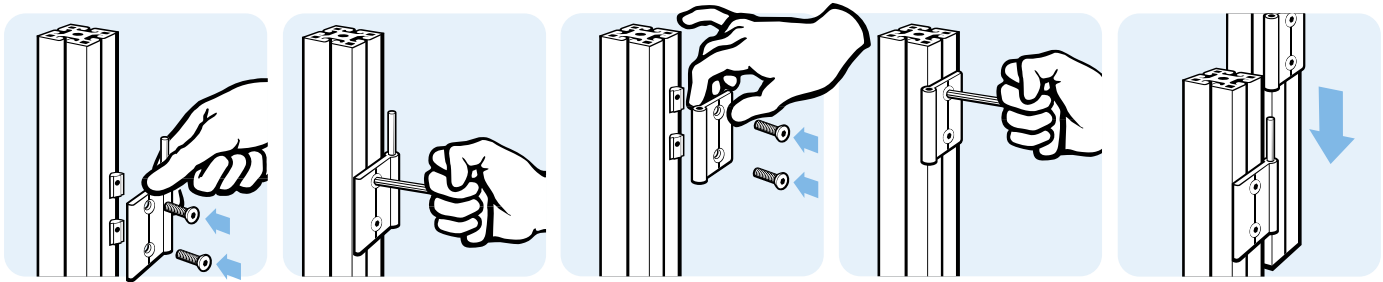

Scharniere Hinges

Aluminium Scharniere Aluminum Hinges
Scharnier-Elemente Hinge Component



AUßENLIEGENDES SCHARNIER-ELEMENT

EXTERNAL HINGE COMPONENT

Ausführung	Aluminium, eloxiert	Model	Aluminum, anodized
Beschreibung	für Flächenelemente und Aluminiumprofile, zur individuellen Zusammenstellung von halbinnenliegenden Scharnieren	Description	For panels and aluminum profiles, for individual assembly of semi-concealed hinges
Material	Flügel: Aluminium Achse: Edelstahl Abdeckkappe: PA, glasfaserverstärkt	Material	Wing: Aluminum Axle: Stainless steel Cover cap: PA, glass fibre reinforced
Befestigung	vorderseitig mit Senkschrauben	Fastening	From the front, using countersunk screws
Liefereinheit	10 Stück	Pack Quantity	10 pieces

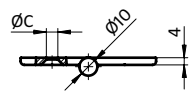
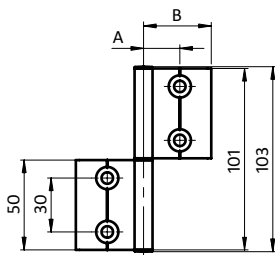

Außenliegendes Scharnier Surface Mounted Hinge	A [mm]	B [mm]	C [mm]	F _{Amax} [N]	F _{Rmax} [N]	Gewicht [g] Weight [g]	Teil-Nr. Part #
20	10.5	18.0	Ø 5.3	150	100	13.5	095AH20
25	12.9	23.4	Ø 6.4	150	100	15.9	095AH25
30	15.2	27.7	Ø 6.4	150	100	18.2	095AH30
38	19.25	35.8	Ø 6.4	150	100	22.0	095AH38
40	20.2	37.7	Ø 6.4	150	100	23.6	095AH40
45	22.7	42.7	Ø 6.4	150	100	26.3	095AH45
50	25.2	47.7	Ø 6.4	150	100	29.0	095AH50
60	30.2	57.7	Ø 6.4	150	100	34.4	095AH60
Achse Axle						12.0	095AIR01
Abdeckkappe Cover cap						0.15	095AIA

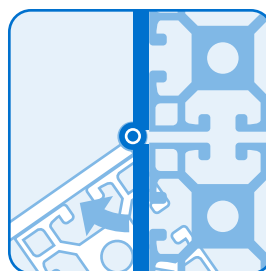
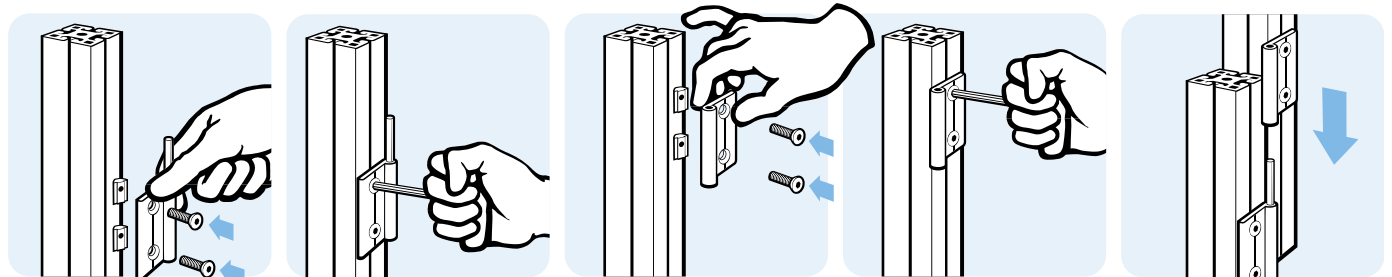

Scharniere Hinges

Zinkdruckguss-scharniere Zinc Die-cast Hinges



ZINKDRUCKGUSS-KOMBISCHARNIER 40 UND 45

ZINC DIE-CAST COMBI HINGE 40 AND 45

Ausführung	nicht aushängbar	Model	Non-detachable
Beschreibung	für Flächenelemente und Aluminiumprofile	Description	To hinge panels or aluminum profiles
Material	Flügel: Zinkdruckguss Achse: Edelstahl	Material	Wings: Zinc die-cast Axle: Stainless steel
Befestigung	vorderseitig mit Schrauben M8	Fastening	From the front, using M8 screws
Liefereinheit	10 Stück	Pack Quantity	10 pieces
Extras	weitere Oberflächen, weitere Farben auf Anfrage	Specials	Other surfaces, other colors on request

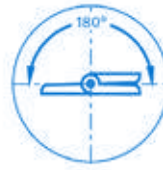
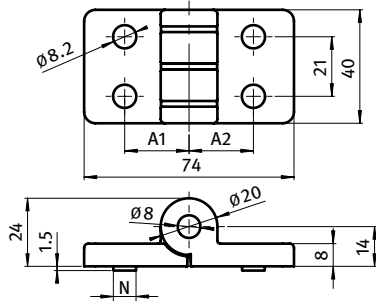

Kombischarnier Combi Hinge	A1 [mm]	A2 [mm]	FMax [N]	FRmax [N]	N	Gewicht [g] Weight [g]	Teil-Nr. Part #
40/40	22.5	22.5	650	1500		189.0	095Z4040F00S
	22.5	22.5	650	1500	8	189.0	095Z4040F08S
	22.5	22.5	650	1500	10	189.0	095Z4040F10S
40/45	22.5	25.0	650	1500		189.0	095Z4045F00S
	22.5	25.0	650	1500	8	189.0	095Z4045F08S
	22.5	25.0	650	1500	10	189.0	095Z4045F10S
45/45	25.0	25.0	650	1500		189.0	095Z4545F00S
	25.0	25.0	650	1500	8	189.0	095Z4545F08S
	25.0	25.0	650	1500	10	189.0	095Z4545F10S



KOMBISCHARNIER MIT KLEMMHEBEL

COMBI HINGE WITH LOCKING LEVER

Ausführung	Zinkdruckguss, nicht aushängbar	Model	Zinc die-cast, non-detachable
Beschreibung	für Flächenelemente und Aluminiumprofile; in jeder Position fixierbar	Description	To hinge panels or aluminum profiles; can be locked at any position
Material	Scharnier: Zinkdruckguss Klemmhebel: Kunststoff PA, schwarz Mechanik: Stahl, verzinkt (RoHS-konform)	Material	Hinge: Zinc die-cast locking lever: Plastic PA, black Mechanism: Steel, zinc plated (RoHS conform)
Befestigung	vorderseitig mit Schrauben M8	Fastening	From the front, using M8 screws
Liefereinheit	10 Stück	Pack Quantity	10 pieces
Extras	weitere Oberflächen, weitere Farben auf Anfrage	Specials	Other surfaces, other colors on request

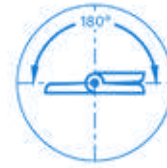
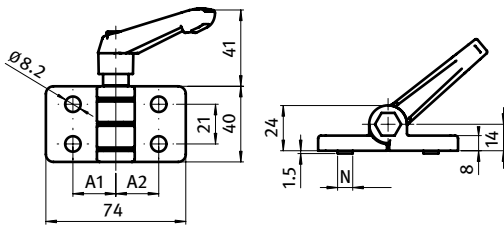

Kombischarnier Combi Hinge	A1 [mm]	A2 [mm]	F _{Amax} [N]	F _{Rmax} [N]	N	Gewicht [g] Weight [g]	Teil-Nr. Part #
40/40	22.5	22.5	650	1500		211.0	095ZF4040F00S
	22.5	22.5	650	1500	8	211.0	095ZF4040F08S
	22.5	22.5	650	1500	10	211.0	095ZF4040F10S
40/45	22.5	25.0	650	1500		211.0	095ZF4045F00S
	22.5	25.0	650	1500	8	211.0	095ZF4045F08S
	22.5	25.0	650	1500	10	211.0	095ZF4045F10S
45/45	25.0	25.0	650	1500		211.0	095ZF4545F00S
	25.0	25.0	650	1500	8	211.0	095ZF4545F08S
	25.0	25.0	650	1500	10	211.0	095ZF4545F10S

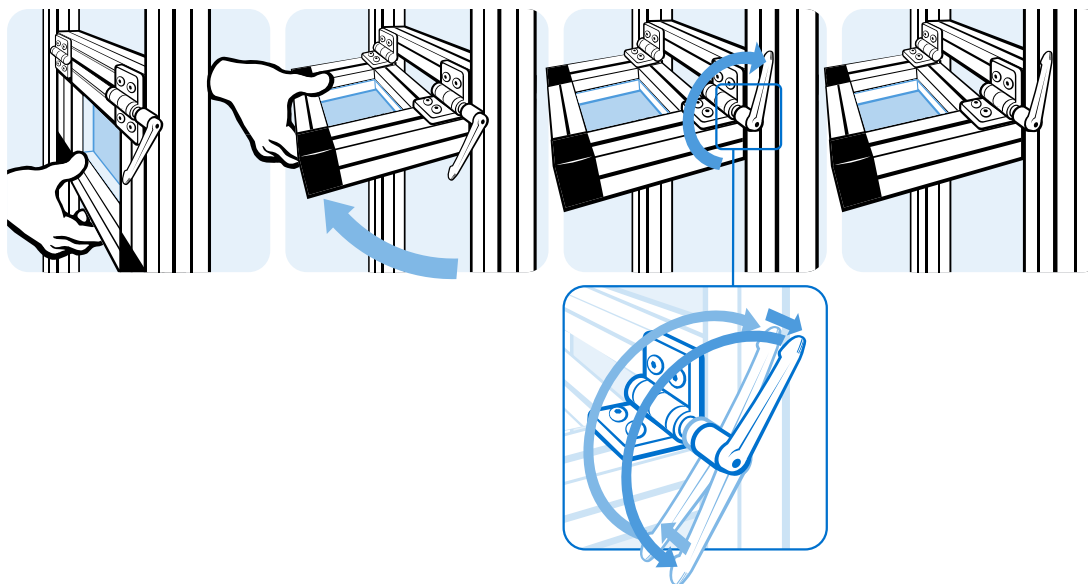

Scharniere Hinges

Zinkdruckguss-scharniere Zinc Die-cast Hinges



ZINKDRUCKGUSS-SCHARNIER 30 MIT LANGLÖCHERN ZINC DIE-CAST HINGE 30 WITH OBLONG HOLES

Ausführung	nicht aushängbar	Model	Non-detachable
Beschreibung	für Flächenelemente und Aluminiumprofile	Description	To hinge panels or aluminum profiles
Material	Flügel: Zinkdruckguss Achse: Edelstahl	Material	Wings: Zinc die-cast Axle: Stainless steel
Befestigung	vorderseitig mit M6 Schrauben	Fastening	From the front, using M6 screws
Liefereinheit	10 Stück	Pack Quantity	10 pieces
Extras	weitere Oberflächen, weitere Farben auf Anfrage	Specials	Other surfaces, other colors on request

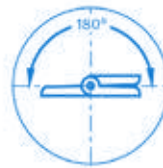
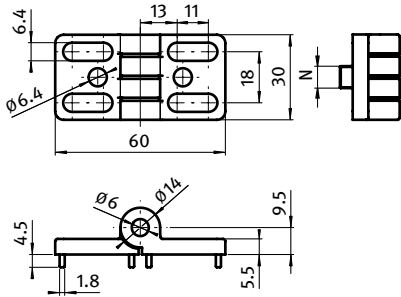

Zinkdruckguss-Scharnier Zinc Die-cast Hinge	F _{max} [N]	F _{Rmax} [N]	N	Gewicht [g] Weight [g]	Teil-Nr. Part #
	350	1000		68.4	095400
	350	1000	6	68.6	095400N06
	350	1000	8	68.8	095400N08

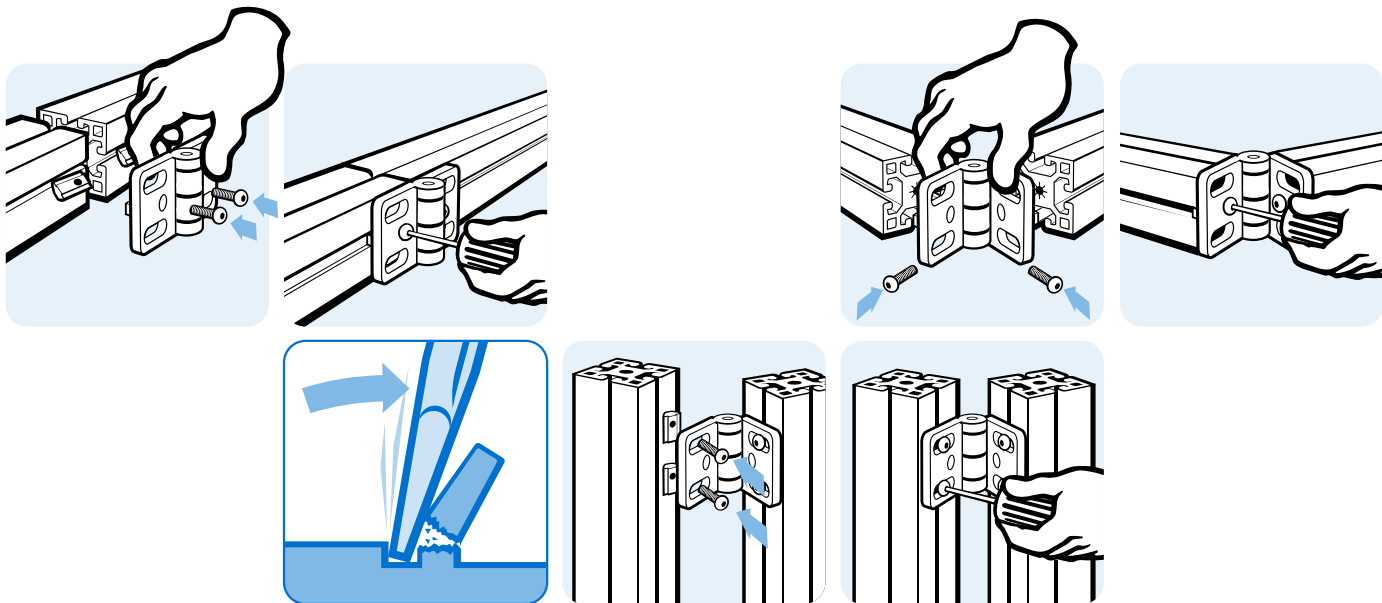

Scharniere Hinges

Zinkdruckgusscharniere Zinc Die-cast Hinges



ZINKDRUCKGUSS-SCHARNIER 40 MIT LANGLÖCHERN ZINC DIE-CAST HINGE 40 WITH OBLONG HOLES

Ausführung	nicht aushängbar	Model	Non-detachable
Beschreibung	für Flächenelemente und Aluminiumprofile	Description	To hinge panels or aluminum profiles
Material	Flügel: Zinkdruckguss Achse: Edelstahl	Material	Wings: Zinc die-cast Axle: Stainless steel
Befestigung	vorderseitig mit M8 Schrauben	Fastening	From the front, using M8 screws
Liefereinheit	10 Stück	Pack Quantity	10 pieces
Extras	weitere Oberflächen, weitere Farben auf Anfrage	Specials	Other surfaces, other colors on request

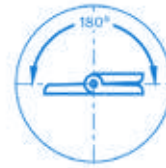
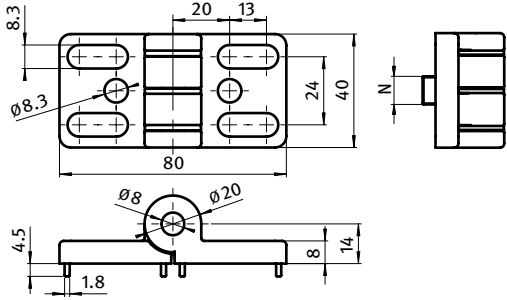

Zinkdruckguss-Scharnier Zinc Die-cast Hinge	FMax [N]	FRmax [N]	N	Gewicht [g] Weight [g]	Teil-Nr. Part #
	500	1200		175.0	095300
	500	1200	8	175.0	095300N08
	500	1200	10	175.0	095300N10

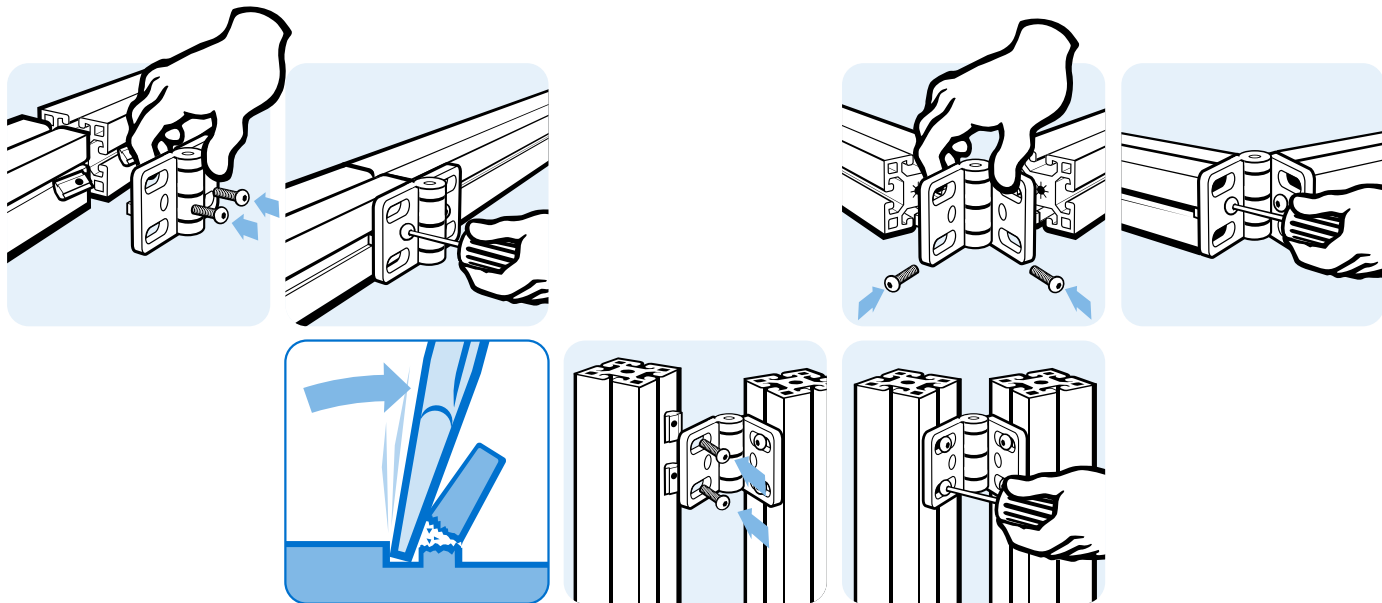

Scharniere Hinges

Zinkdruckguss-scharniere Zinc Die-cast Hinges



ZINKDRUCKGUSS-SCHARNIER MIT KLEMMHEBEL

ZINC DIE-CAST HINGE WITH LOCKING LEVER

Ausführung	nicht aushängbar	Model	Non-detachable
Beschreibung	für Flächenelemente und Aluminiumprofile, in jeder Position fixierbar	Description	For panels and aluminum profiles, can be locked in any position
Material	Flügel: Zinkdruckguss Klemmhebel: Kunststoff PA, glasfaserverstärkt Mechanik: Stahl, schwarz verzinkt (RoHS-konform)	Material	Wings: Zinc die-cast locking lever: Plastic PA, glass fiber reinforced Mechanism: Steel, black zinc plated (RoHS conform)
Befestigung	vorderseitig mit M8 Schrauben	Fastening	From the front, using M8 screws
Liefereinheit	10 Stück	Pack Quantity	10 pieces
Extras	weitere Oberflächen, weitere Farben auf Anfrage	Specials	Other surfaces, other colors on request

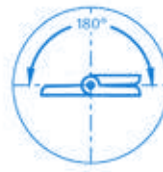
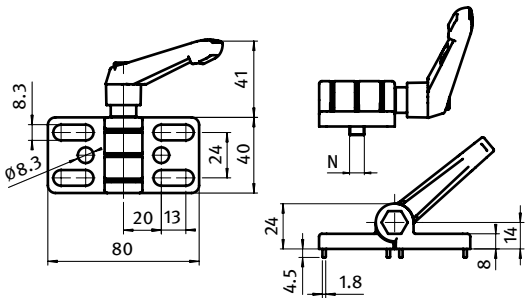

Zinkdruckguss-Scharnier Zinc Die-cast Hinge	F _{Amax} [N]	F _{Rmax} [N]	N	Gewicht [g] Weight [g]	Teil-Nr. Part #
	500	1200		197.0	095300F
	500	1200	8	197.0	095300FN08
	500	1200	10	197.0	095300FN10

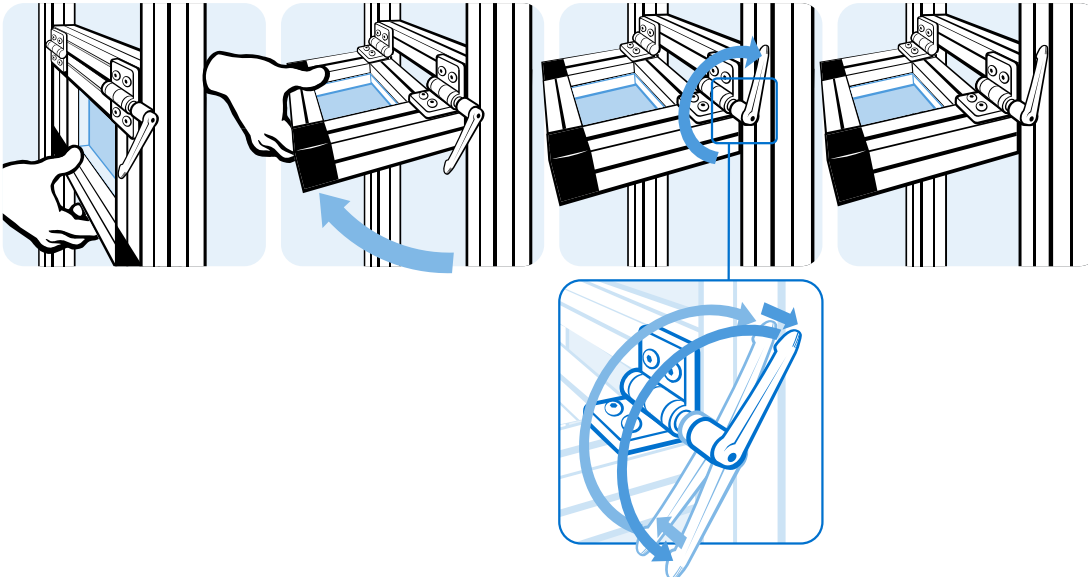

Scharniere Hinges

Zinkdruckgusscharniere Zinc Die-cast Hinges



MINISCHARNIER

MINI HINGE

Ausführung	Zinkdruckguss, aushängbar	Model	Zinc die-cast, Detachable
Beschreibung	Minischarnier mit vielseitigen Anwendungsmöglichkeiten, für enge Montagesituationen	Description	Mini hinge for various applications, especially in limited space
Material	Flügel: Zinkdruckguss Achse: Edelstahl	Material	Wings: Zinc die-cast Axle: Stainless steel
Liefereinheit	10 Stück	Pack Quantity	10 pieces

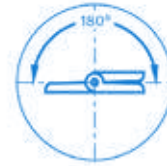
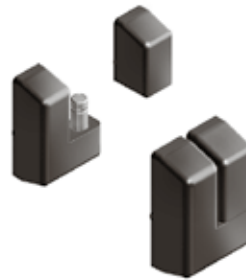
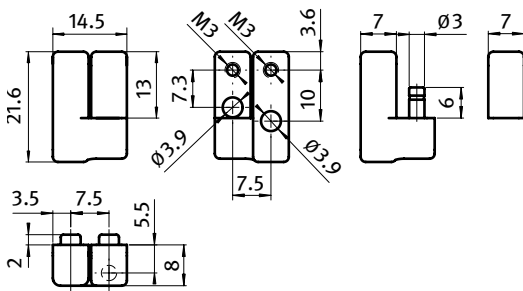

Minischarnier Mini Hinge	F _{Amax} [N]	F _{Rmax} [N]	Gewicht [g] Weight [g]	Teil-Nr Part#
Montage links , aushängbar <i>Left hand, lift off</i>	100	100	12.0	095023L
Montage rechts, aushängbar <i>Right hand, lift off</i>	100	100	12.0	095023R

Scharniere Hinges

Zinkdruckgusscharniere Zinc Die-cast Hinges



METALLSCHARNIER 40 × 40

METAL HINGE 40 × 40

Ausführung	Zinkdruckguss, nicht aushängbar	Model	Zinc die-cast, non-detachable
Beschreibung	robustes Scharnier für den Einsatz links und rechts	Description	Sturdy hinge for right and left hand application
Material	Flügel: Zinkdruckguss Achse: Edelstahl	Material	Wings: Zinc die-cast Axle: Stainless steel
Befestigung	vorderseitig mit Senkschrauben	Fastening	From the front, using countersunk screws
Liefereinheit	10 Stück	Pack Quantity	10 pieces

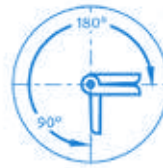
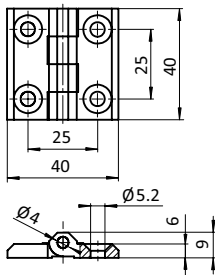

Metallscharnier 40 × 40
Metal Hinge 40 × 40

F_{Amax}
[N]

F_{Rmax}
[N]

Gewicht [g]
Weight [g]

Teil-Nr.
Part #

800

1500

45.0

095005

Scharniere Hinges

Zinkdruckgusscharniere Zinc Die-cast Hinges



METALLSCHARNIER 50 × 50

METAL HINGE 50 × 50

Ausführung	Zinkdruckguss, nicht aushängbar	Model	Zinc die-cast, non-detachable
Beschreibung	robustes Scharnier für den Einsatz links und rechts	Description	Sturdy hinge for right and left hand application
Material	Flügel: Zinkdruckguss Achse: Edelstahl	Material	Wings: Zinc die-cast Axle: Stainless steel
Befestigung	vorderseitig mit Senkschrauben	Fastening	From the front, using countersunk screws
Liefereinheit	10 Stück	Pack Quantity	10 pieces

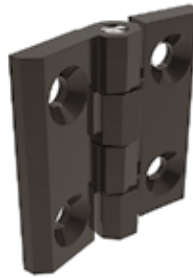
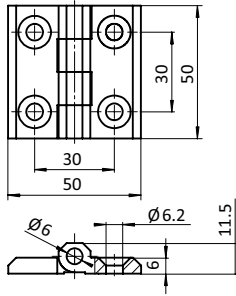

Metallscharnier 50 × 50
Metal Hinge 50 × 50

F_{Amax}
[N]

F_{Rmax}
[N]

Gewicht [g]
Weight [g]

Teil-Nr.
Part #

1000

1800

90.0

095006

Scharniere Hinges

Zinkdruckgusscharniere Zinc Die-cast Hinges



METALLSCHARNIER 50 × 63

METAL HINGE 50 × 63

Ausführung	Zinkdruckguss, nicht aushängbar	Model	Zinc die-cast, non-detachable
Beschreibung	robustes Scharnier für den Einsatz links und rechts	Description	Sturdy hinge for right and left hand application
Material	Flügel: Zinkdruckguss Achse: Edelstahl	Material	Wings: Zinc die-cast Axle: Stainless steel
Befestigung	vorderseitig mit Senkschrauben	Fastening	From the front, using countersunk screws
Liefereinheit	10 Stück	Pack Quantity	10 pieces

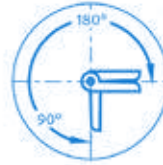
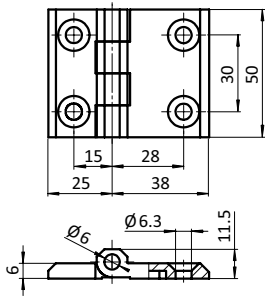

Metallscharnier 50 × 63
Metal Hinge 50 × 63

F_{Amax}
[N]

F_{Rmax}
[N]

Gewicht [g]
Weight [g]

Teil-Nr.
Part #

1400

2200

106.0

095010



METALLSCHARNIER 50 × 76

METAL HINGE 50 × 76

Ausführung	Zinkdruckguss, nicht aushängbar	Model	Zinc die-cast, non-detachable
Beschreibung	robustes Scharnier für den Einsatz links und rechts	Description	Sturdy hinge for right and left hand application
Material	Flügel: Zinkdruckguss Achse: Edelstahl	Material	Wings: Zinc die-cast Axle: Stainless steel
Befestigung	vorderseitig mit Senkschrauben	Fastening	From the front, using countersunk screws
Liefereinheit	10 Stück	Pack Quantity	10 pieces

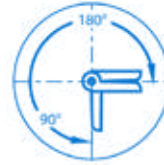
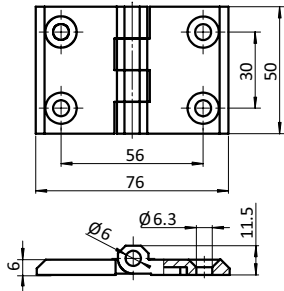

Metallscharnier 50 × 76 Metal Hinge 50 × 76	F _{Amax} [N]	F _{Rmax} [N]	Gewicht [g] Weight [g]	Teil-Nr. Part #
	600	1800	145.0	095007

2

Scharniere Hinges

Zinkdruckgusscharniere Zinc Die-cast Hinges



METALLSCHARNIER 60 × 60

METAL HINGE 60 × 60

Ausführung	Zinkdruckguss, nicht aushängbar	Model	Zinc die-cast, non-detachable
Beschreibung	robustes Scharnier für den Einsatz links und rechts	Description	Sturdy hinge for right and left hand application
Material	Flügel: Zinkdruckguss Achse: Edelstahl	Material	Wings: Zinc die-cast Axle: Stainless steel
Befestigung	vorderseitig mit Senkschrauben	Fastening	From the front, using countersunk screws
Liefereinheit	10 Stück	Pack Quantity	10 pieces

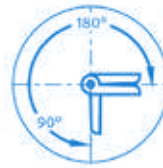
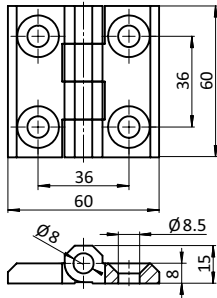

Metallscharnier 60 × 60
Metal Hinge 60 × 60

F_{Amax}
[N]

F_{Rmax}
[N]

Gewicht [g]
Weight [g]

Teil-Nr.
Part #

1400

2200

168.0

095009



METALLSCHARNIER 60 × 74

METAL HINGE 60 × 74

Ausführung	Zinkdruckguss, nicht aushängbar	Model	Zinc die-cast, non-detachable
Beschreibung	robustes Scharnier für den Einsatz links und rechts	Description	Sturdy hinge for right and left hand application
Material	Flügel: Zinkdruckguss Achse: Edelstahl	Material	Wings: Zinc die-cast Axle: Stainless steel
Befestigung	vorderseitig mit Senkschrauben	Fastening	From the front, using countersunk screws
Liefereinheit	10 Stück	Pack Quantity	10 pieces

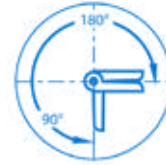
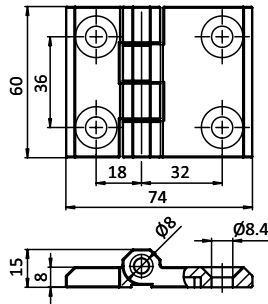

Metallscharnier 60 × 74 Metal Hinge 60 × 74	F _{Amax} [N]	F _{Rmax} [N]	Gewicht [g] Weight [g]	Teil-Nr. Part #
	1200	2200	196.0	095017

2

Scharniere Hinges

Zinkdruckgusscharniere Zinc Die-cast Hinges



METALLSCHARNIER 60 × 76

METAL HINGE 60 × 76

Ausführung	Zinkdruckguss, nicht aushängbar	Model	Zinc die-cast, non-detachable
Beschreibung	robustes Scharnier für den Einsatz links und rechts	Description	Sturdy hinge for right and left hand application
Material	Flügel: Zinkdruckguss Achse: Edelstahl	Material	Wings: Zinc die-cast Axle: Stainless steel
Befestigung	vorderseitig mit Senkschrauben	Fastening	From the front, using countersunk screws
Liefereinheit	10 Stück	Pack Quantity	10 pieces

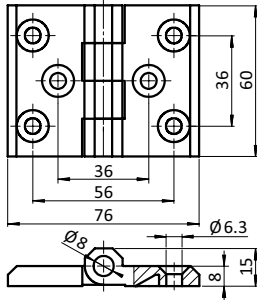

Metallscharnier 60 × 76
Metal Hinge 60 × 76

F_{Amax}
[N]

F_{Rmax}
[N]

Gewicht [g]
Weight [g]

Teil-Nr.
Part #

1200

2200

197.0

095008

Scharniere Hinges

Zinkdruckgusscharniere Zinc Die-cast Hinges



METALLSCHARNIER 60 × 90

METAL HINGE 60 × 90

Ausführung	Zinkdruckguss, nicht aushängbar	Model	Zinc die-cast, non-detachable
Beschreibung	robustes Scharnier für den Einsatz links und rechts	Description	Sturdy hinge for right and left hand application
Material	Flügel: Zinkdruckguss Achse: Edelstahl	Material	Wings: Zinc die-cast Axle: Stainless steel
Befestigung	vorderseitig mit Senkschrauben	Fastening	From the front, using countersunk screws
Liefereinheit	10 Stück	Pack Quantity	10 pieces

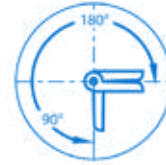
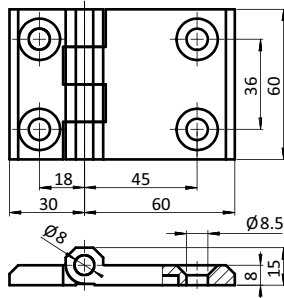

Metallscharnier 60 × 90 Metal Hinge 60 × 90	F _{Amax} [N]	F _{Rmax} [N]	Gewicht [g] Weight [g]	Teil-Nr. Part #
	800	2200	218.0	095027

2

Scharniere Hinges

Zinkdruckgusscharniere Zinc Die-cast Hinges



METALLSCHARNIER 60 × 120

METAL HINGE 60 × 120

Ausführung	Zinkdruckguss, nicht aushängbar	Model	Zinc die-cast, non-detachable
Beschreibung	robustes Scharnier für den Einsatz links und rechts	Description	Sturdy hinge for right and left hand application
Material	Flügel: Zinkdruckguss Achse: Edelstahl	Material	Wings: Zinc die-cast Axle: Stainless steel
Befestigung	vorderseitig mit Senkschrauben	Fastening	From the front, using countersunk screws
Liefereinheit	10 Stück	Pack Quantity	10 pieces

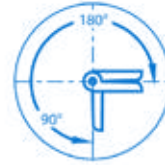
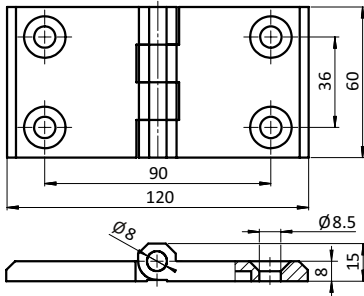

Metallscharnier 60 × 120
Metal Hinge 60 × 120

F_{Amax}
[N]

F_{Rmax}
[N]

Gewicht [g]
Weight [g]

Teil-Nr.
Part #

700

2200

281.0

095028

Scharniere Hinges

Zinkdruckgusscharniere Zinc Die-cast Hinges



2D-SCHARNIER, JUSTIERBAR IN ZWEI AXHSEN

2D HINGE, ADJUSTABLE IN TWO DIRECTIONS

Ausführung	nicht aushängbar	Model	Non-detachable
Beschreibung	robustes Scharnier für den Einsatz links und rechts, justierbar	Description	Sturdy hinge for right and left hand application, adjustable
Material	Flügel: Zinkdruckguss Achse: Edelstahl	Material	Wings: Zinc die-cast Axle: Stainless steel
Befestigung	vorderseitig mit Senkschrauben M6	Fastening	From the front, using M6 countersunk screws
Liefereinheit	10 Stück	Pack Quantity	10 pieces

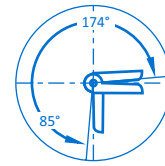
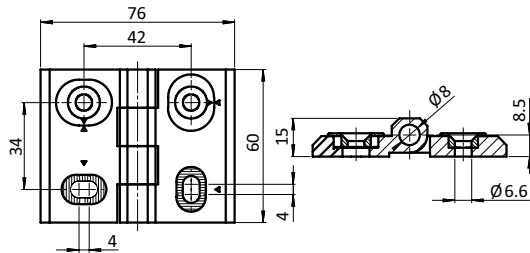

2D-Scharnier 2D Hinge	F _{Amax} [N]	F _{Rmax} [N]	Gewicht [g] Weight [g]	Teil-Nr. Part #
justierbar in zwei Achsen <i>Adjustable in two directions</i>	1200	2200	190.0	095014

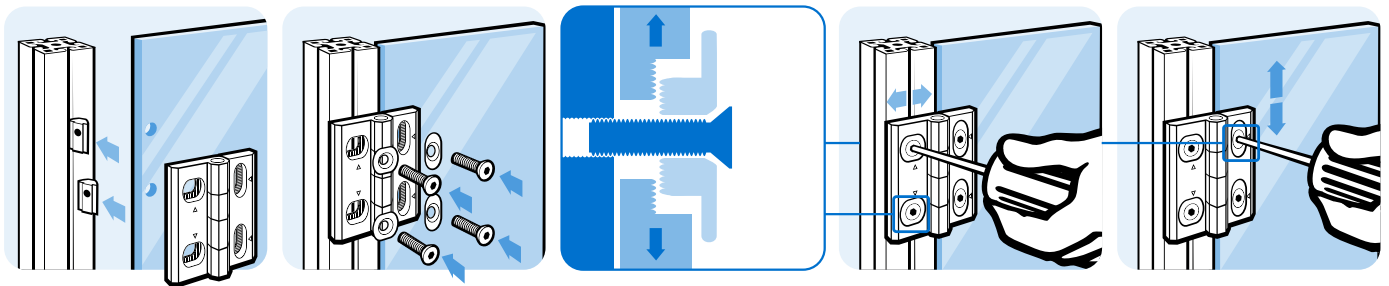

Scharniere Hinges

Zinkdruckgusscharniere Zinc Die-cast Hinges



2D-SCHARNIER, JUSTIERBAR NUR IN DER HÖHE

2D HINGE, ONLY ADJUSTABLE VERTICALLY

Ausführung	nicht aushängbar	Model	Non-detachable
Beschreibung	robustes Scharnier für den Einsatz links und rechts, justierbar	Description	Sturdy hinge for right and left hand application, adjustable
Material	Flügel: Zinkdruckguss Achse: Edelstahl	Material	Wings: Zinc die-cast Axle: Stainless steel
Befestigung	vorderseitig mit Senkschrauben M6	Fastening	From the front, using M6 countersunk screws
Liefereinheit	10 Stück	Pack Quantity	10 pieces

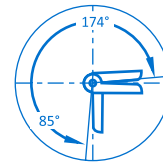
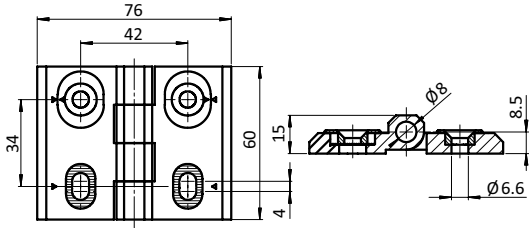

2D-Scharnier 2D Hinge	F _{Amax} [N]	F _{Rmax} [N]	Gewicht [g] Weight [g]	Teil-Nr. Part #
justierbar nur in der Höhe <i>Only adjustable vertically</i>	1200	2200	190.0	095015

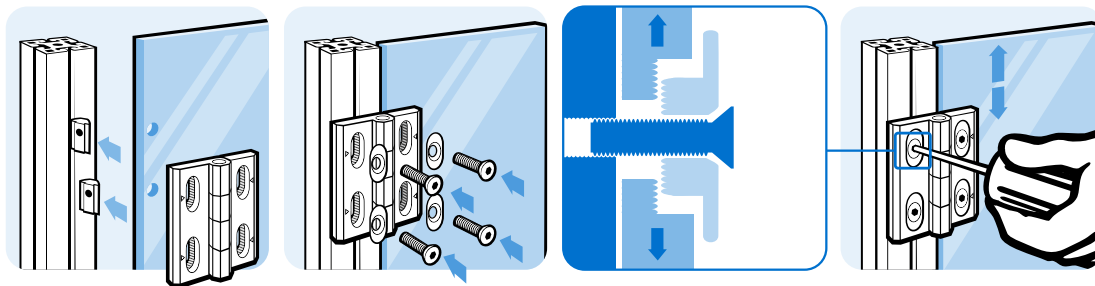

Scharniere Hinges

Zinkdruckgusscharniere Zinc Die-cast Hinges



2D-SCHARNIER, JUSTIERBAR NUR IN DER BREITE

2D HINGE, ONLY ADJUSTABLE HORIZONTALLY

Ausführung	nicht aushängbar	Model	Non-detachable
Beschreibung	robustes Scharnier für den Einsatz links und rechts, justierbar	Description	Sturdy hinge for right and left hand application, adjustable
Material	Flügel: Zinkdruckguss Achse: Edelstahl	Material	Wings: Zinc die-cast Axle: Stainless steel
Befestigung	vorderseitig mit Senkschrauben M6	Fastening	From the front, using M6 countersunk screws
Liefereinheit	10 Stück	Pack Quantity	10 pieces

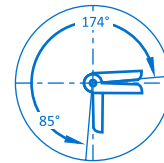
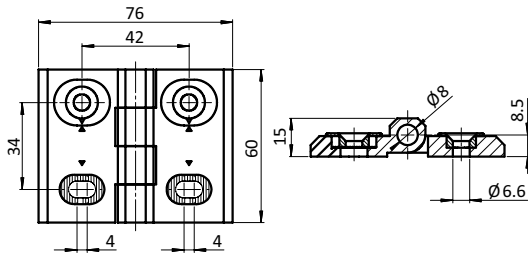

2D-Scharnier 2D Hinge	F _{Amax} [N]	F _{Rmax} [N]	Gewicht [g] Weight [g]	Teil-Nr. Part #
justierbar nur in der Breite <i>Only adjustable horizontally</i>	1200	2200	190.0	095016

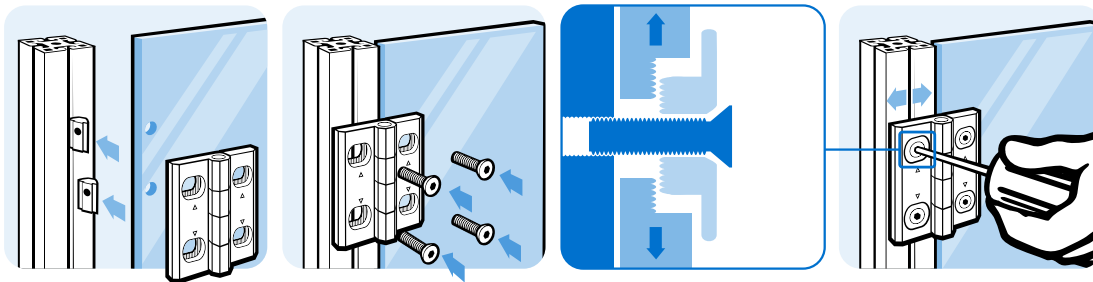

Scharniere Hinges

Zinkdruckgusscharniere Zinc Die-cast Hinges



METALLSCHARNIER 40 × 38 M. KONSTANTER FRIKTION METAL HINGE 40 × 38 WITH CONSTANT FRICTION

Ausführung	nicht aushängbar	Model	Non-detachable
Beschreibung	für Flächenelemente und Aluminiumprofile, hält Türen und Klappen in jedem Winkel fest; auch als Aufsteller für leichte Klappen einsetzbar	Description	For panels and aluminum profiles; keeps doors open at any angle; also supports lightweight horizontal doors
Material	Flügel: Zinkdruckguss Achse: Stahl, Schmieröl, O-Ring	Material	Wings: Zinc die-cast Axle: Steel, lubricating grease, o-ring
Befestigung	mit Schrauben M4	Fastening	Using M4 screws
Liefereinheit	10 Stück	Pack Quantity	10 pieces
Hinweis	* ± 20% des Nominalwertes bis zu 20.000 Zyklen	Tip	* ± 20% of the nominal value up to 20.000 cycles

2

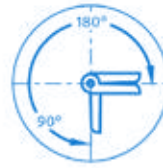
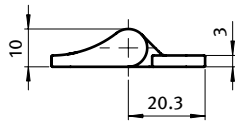
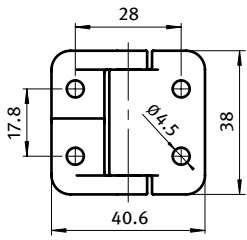

Metallscharnier Metal Hinge	F _{Amax} [N]	F _{Rmax} [N]	Friktionsmoment* [Nm] Friction Torque* [Nm]	Gewicht [g] Weight [g]	Teil-Nr. Part #
	800	1500	0.9	40.0	095029
	800	1500	1.8	40.0	095030

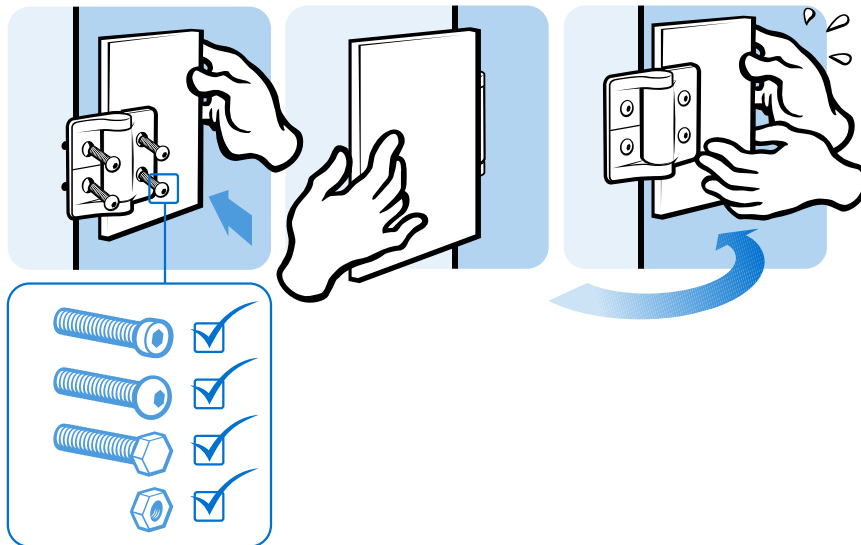

Scharniere Hinges

Zinkdruckgusscharniere Zinc Die-cast Hinges



METALLSCHARNIER 58 × 51 M. KONSTANTER FRIKTION *METAL HINGE 58 × 51 WITH CONSTANT FRICTION*

Ausführung	nicht aushängbar	Model	Non-detachable
Beschreibung	für Flächenelemente und Aluminiumprofile, hält Türen und Klappen in jedem Winkel fest; auch als Aufsteller für leichte Klappen einsetzbar	Description	For panels and aluminum profiles; keeps doors open at any angle; also supports lightweight horizontal doors
Material	Flügel: Zinkdruckguss Achse: Stahl, Schmieröl, O-Ring	Material	Wings: Zinc die-cast Axle: Steel, lubricating grease, o-ring
Befestigung	mit Schrauben M5	Fastening	Using M5 screws
Liefereinheit	10 Stück	Pack Quantity	10 pieces
Hinweis	* ± 20% des Nominalwertes bis zu 20.000 Zyklen	Tip	* ± 20% of the nominal value up to 20.000 cycles

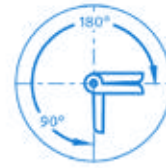
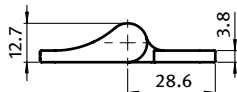
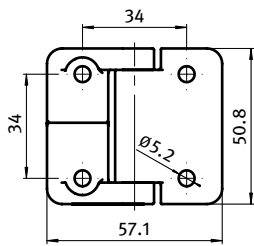

Metallscharnier Metal Hinge	F _{Amax} [N]	F _{Rmax} [N]	Friktionsmoment* [Nm] Friction Torque* [Nm]	Gewicht [g] Weight [g]	Teil-Nr. Part #
	800	1500	1.8	84.0	095031
	800	1500	2.3	84.0	095032
	800	1500	3.4	84.0	095033

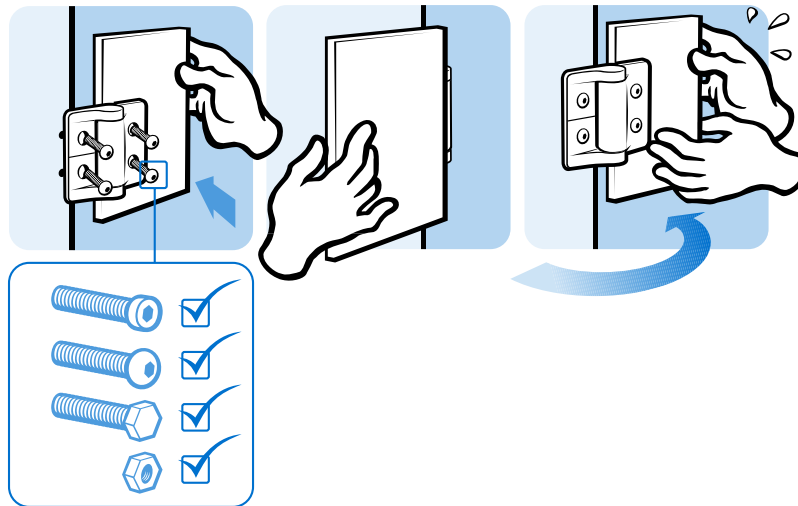



RASTSCHARNIER

POSITIONING HINGE

Ausführung	nicht aushängbar	Model	Non-detachable
Beschreibung	für Flächenelemente und Aluminiumprofile, hält Türen und Klappen im Winkel von 85° oder 175° offen bzw. hält sie sicher verschlossen; auch als Aufsteller für leichte Klappen einsetzbar	Description	For panels and aluminum profiles; holds a door open at an angle of 85° or 175° or keeps it securely closed; also supports lightweight horizontal doors
Material	Flügel: Zinkdruckguss Achse: Edelstahl	Material	Wings: Zinc die-cast Axle: Stainless steel
Befestigung	vorderseitig mit Senkschrauben M6	Fastening	From the front, using M6 countersunk screws
Liefereinheit	10 Stück	Pack Quantity	10 pieces
Hinweis	* ± 20% des Sollwertes	Tip	* ± 20% of the setting value

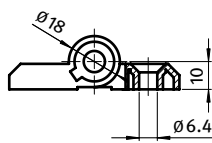
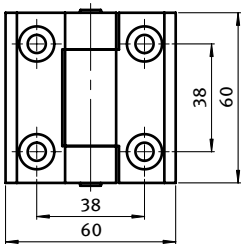

Rastscharnier Positioning Hinge	F _{max} [N]	F _{Rmax} [N]	Rastmoment* [Nm] Cogging Torque* [Nm]	Gewicht [g] Weight [g]	Teil-Nr. Part #
	1000	1800	1.1	140.0	095009F

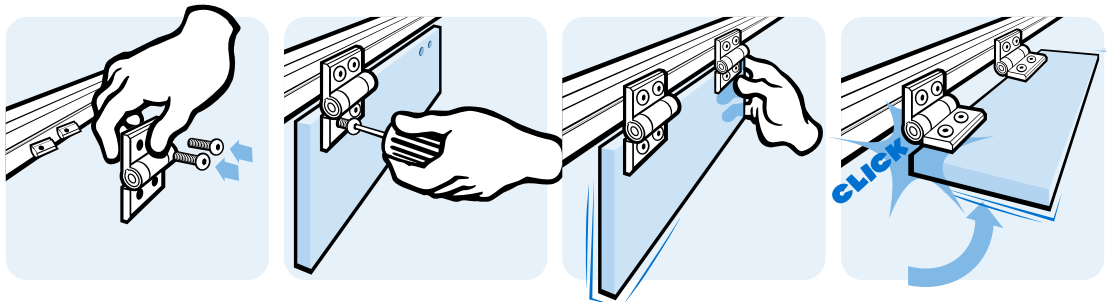



METALLSCHARNIER LEICHT (SET)

LIGHT METAL HINGE (SET)

Ausführung nicht aushängbar	Model Non-detachable
Beschreibung für Flächenelemente und Aluminiumprofile	Description To hinge panels or aluminum profiles
Set 1 Metallscharnier leicht, 3 Schrauben ISO 7380 - M5 × 8, 1 Schraube DIN 903 - M5 × 16, 1 Mutter DIN 934 - M5, 1 Scheibe DIN 125 Ø 5,3 - schwarz verzinkt (RoHS-konform)	Set 1 light metal hinge, 3 screws ISO 7380 - M5 × 8, 1 screw DIN 903 - M5 × 16, 1 nut - DIN 934 - M5, 1 washer DIN 125 Ø 5.3 - black zinc plated (RoHS compliant)
Material Stahl	Material Steel
Liefereinheit 10 Stück	Pack Quantity 10 pieces
Extras weitere Oberflächen, weitere Farben auf Anfrage	Specials Other surfaces, other colors on request

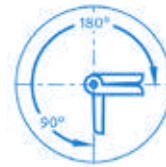
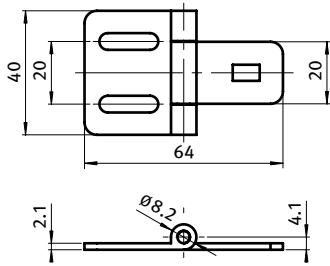

Metallscharnier Metal Hinge	F _{Amax} [N]	F _{Rmax} [N]	Gewicht [g] Weight [g]	Teil-Nr. Part #
	250	75	39.0	095990S

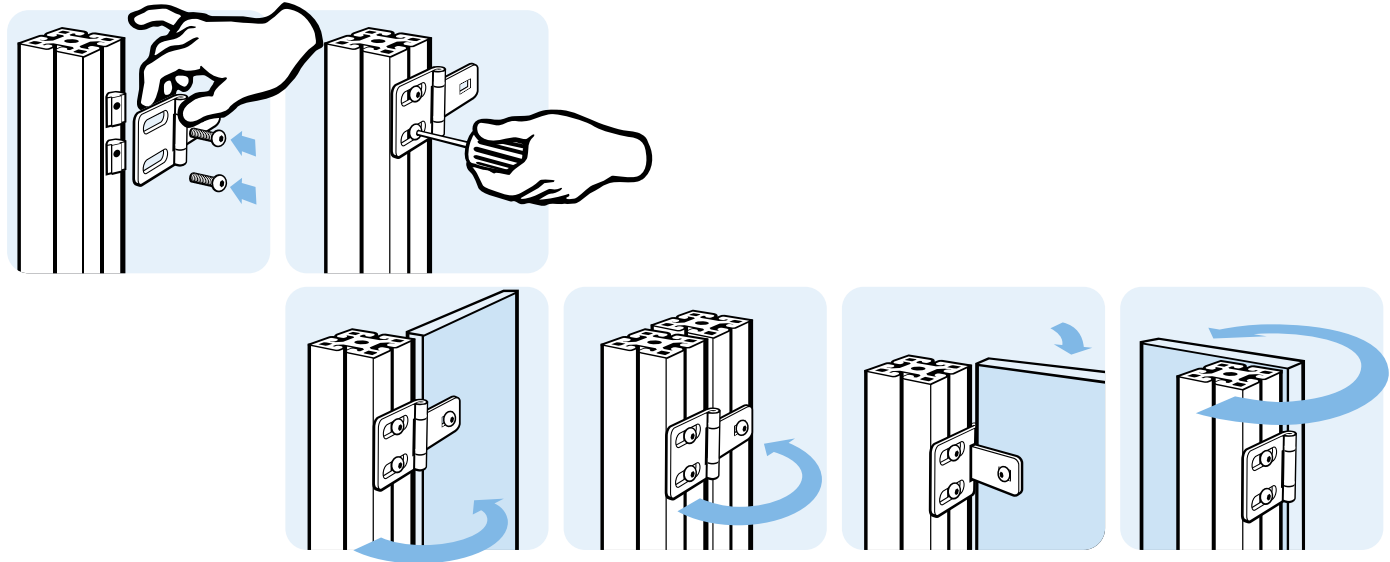

Scharniere Hinges

Edelstahlscharniere *Stainless Steel Hinges*



EDELSTAHL-KOMBISCHARNIER 20

STAINLESS STEEL COMBI HINGE 20

Ausführung	nicht aushängbar	Model	<i>Non-detachable</i>
Beschreibung	für Flächenelemente und Aluminiumprofile	Description	<i>To hinge panels or aluminum profiles</i>
Material	Flügel: Edelstahl 1.4401 Achse: Edelstahl 1.4104	Material	<i>Wing: Stainless steel SS316 Axle: Stainless steel SS430 F</i>
Befestigung	vorderseitig mit Senkschrauben M4	Fastening	<i>From the front, using M4 countersunk screws</i>
Liefereinheit	10 Stück	Pack Quantity	<i>10 pieces</i>

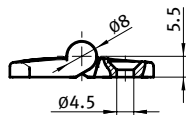
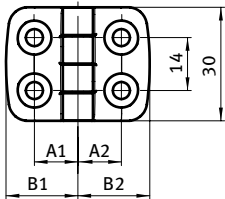

Kombischarnier <i>Combi Hinge</i>	A1 [mm]	A2 [mm]	B1 [mm]	B2 [mm]	F _{Amax} [N]	F _{Rmax} [N]	Bezeichnung <i>Description</i>	Gewicht [g] <i>Weight [g]</i>	Teil-Nr. <i>Part #</i>
nicht aushängbar <i>Non-detachable</i>	11.5	11.5	19.0	19.0	450	700	20/20	138.0	095E2020F

Scharniere Hinges

Edelstahlscharniere *Stainless Steel Hinges*

Kombischarniere *Combi Hinges*



EDELSTAHL-KOMBISCHARNIER 25

STAINLESS STEEL COMBI HINGE 25

Ausführung	aushängbar	Model	Detachable
Beschreibung	für Flächenelemente und Aluminiumprofile	Description	To hinge panels or aluminum profiles
Material	Flügel: Edelstahl 1.4401 Achse: Edelstahl 1.4104	Material	Wing: Stainless steel SS316 Axle: Stainless steel SS430 F
Befestigung	vorderseitig mit Senkschrauben M6	Fastening	From the front, using M6 countersunk screws
Liefereinheit	10 Stück	Pack Quantity	10 pieces

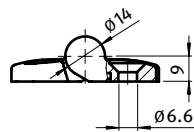
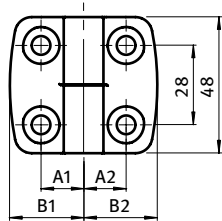

Kombischarnier Combi Hinge	A1 [mm]	A2 [mm]	B1 [mm]	B2 [mm]	F _{Amax} [N]	F _{Rmax} [N]	Bezeichnung Description	Gewicht [g] Weight [g]	Teil-Nr. Part #
L: links <i>Left</i>	15.0	15.0	26.0	26.0	625	900	25/25	144.0	095E2525L
R: rechts <i>Right</i>	15.0	15.0	26.0	26.0	625	900	25/25	144.0	095E2525R

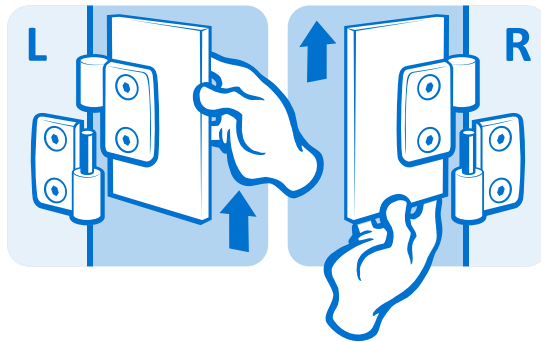

Scharniere Hinges

Edelstahlscharniere *Stainless Steel Hinges*

Kombischarniere *Combi Hinges*



EDELSTAHL-KOMBISCHARNIER 25

STAINLESS STEEL COMBI HINGE 25

Ausführung	nicht aushängbar	Model	<i>Non-detachable</i>
Beschreibung	für Flächenelemente und Aluminiumprofile	Description	<i>To hinge panels or aluminum profiles</i>
Material	Flügel: Edelstahl 1.4401 Achse: Edelstahl 1.4104	Material	<i>Wing: Stainless steel SS316 Axle: Stainless steel SS430 F</i>
Befestigung	vorderseitig mit Senkschrauben M6	Fastening	<i>From the front, using M6 countersunk screws</i>
Liefereinheit	10 Stück	Pack Quantity	<i>10 pieces</i>

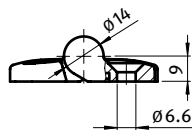
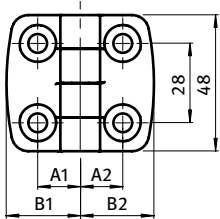

Kombischarnier <i>Combi Hinge</i>	A1 [mm]	A2 [mm]	B1 [mm]	B2 [mm]	F _{Amax} [N]	F _{Rmax} [N]	Bezeichnung <i>Description</i>	Gewicht [g] <i>Weight [g]</i>	Teil-Nr. <i>Part #</i>
nicht aushängbar <i>Non-detachable</i>	15.0	15.0	26.0	26.0	560	700	25/25	143.0	095E2525F

Scharniere Hinges

Edelstahlscharniere *Stainless Steel Hinges*

Kombischarniere *Combi Hinges*



EDELSTAHL-KOMBISCHARNIER 30

STAINLESS STEEL COMBI HINGE 30

Ausführung	aushängbar	Model	Detachable
Beschreibung	für Flächenelemente und Aluminiumprofile	Description	To hinge panels or aluminum profiles
Material	Flügel: Edelstahl 1.4401 Achse: Edelstahl 1.4104	Material	Wing: Stainless steel SS316 Axle: Stainless steel SS430 F
Befestigung	vorderseitig mit Senkschrauben M6	Fastening	From the front, using M6 countersunk screws
Liefereinheit	10 Stück	Pack Quantity	10 pieces

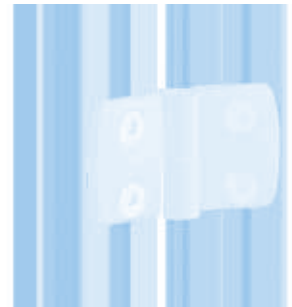
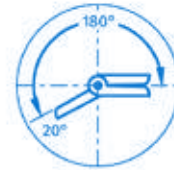
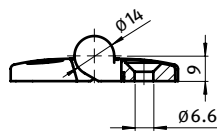
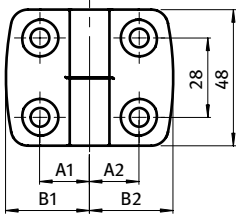

Kombischarnier Combi Hinge	A1 [mm]	A2 [mm]	B1 [mm]	B2 [mm]	F _{Amax} [N]	F _{Rmax} [N]	Bezeichnung Description	Gewicht [g] Weight [g]	Teil-Nr. Part #
L: links <i>Left</i>	17.5	17.5	29.5	29.5	710	1000	30/30	160.0	095E3030L
R: rechts <i>Right</i>	17.5	17.5	29.5	29.5	710	1000	30/30	160.0	095E3030R

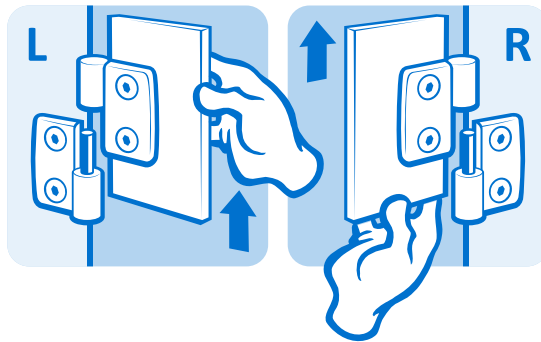

Scharniere Hinges

Edelstahlscharniere *Stainless Steel Hinges*

Kombischarniere *Combi Hinges*



EDELSTAHL-KOMBISCHARNIER 30

STAINLESS STEEL COMBI HINGE 30

Ausführung	nicht aushängbar	Model	<i>Non-detachable</i>
Beschreibung	für Flächenelemente und Aluminiumprofile	Description	<i>To hinge panels or aluminum profiles</i>
Material	Flügel: Edelstahl 1.4401 Achse: Edelstahl 1.4104	Material	<i>Wing: Stainless steel SS316 Axle: Stainless steel SS430 F</i>
Befestigung	vorderseitig mit Senkschrauben M6	Fastening	<i>From the front, using M6 countersunk screws</i>
Liefereinheit	10 Stück	Pack Quantity	<i>10 pieces</i>

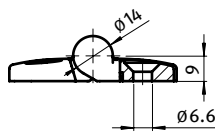
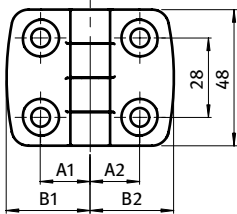

Kombischarnier <i>Combi Hinge</i>	A1 [mm]	A2 [mm]	B1 [mm]	B2 [mm]	F _{Amax} [N]	F _{Rmax} [N]	Bezeichnung <i>Description</i>	Gewicht [g] <i>Weight [g]</i>	Teil-Nr. <i>Part #</i>
nicht aushängbar <i>Non-detachable</i>	17.5	17.5	29.5	29.5	575	800	30/30	167.0	095E3030F

Scharniere Hinges

Edelstahlscharniere *Stainless Steel Hinges*

Kombischarniere *Combi Hinges*



EDELSTAHL-KOMBISCHARNIER 40

STAINLESS STEEL COMBI HINGE 40

Ausführung	aushängbar	Model	Detachable
Beschreibung	für Flächenelemente und Aluminiumprofile	Description	To hinge panels or aluminum profiles
Material	Flügel: Edelstahl 1.4401 Achse: Edelstahl 1.4104	Material	Wing: Stainless steel SS316 Axle: Stainless steel SS430 F
Befestigung	vorderseitig mit Senkschrauben M6	Fastening	From the front, using M6 countersunk screws
Liefereinheit	10 Stück	Pack Quantity	10 pieces

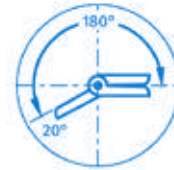
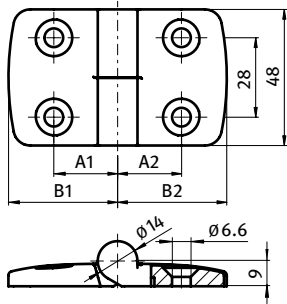

Kombischarnier Combi Hinge	A1 [mm]	A2 [mm]	B1 [mm]	B2 [mm]	F _{Amax} [N]	F _{Rmax} [N]	Bezeichnung Description	Gewicht [g] Weight [g]	Teil-Nr. Part #
L: links <i>Left</i>	22.5	22.5	38.5	38.5	500	1200	40/40	204.0	095E4040L
R: rechts <i>Right</i>	22.5	22.5	38.5	38.5	500	1200	40/40	204.0	095E4040R

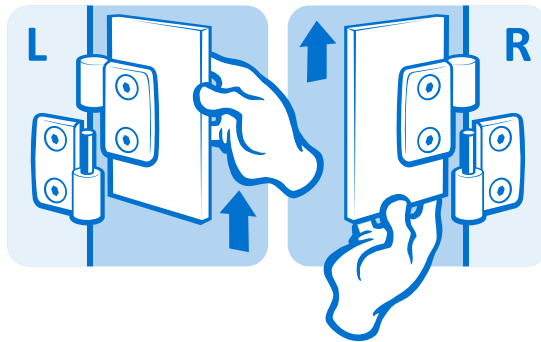

Scharniere Hinges

Edelstahlscharniere *Stainless Steel Hinges*

Kombischarniere *Combi Hinges*



EDELSTAHL-KOMBISCHARNIER 40

STAINLESS STEEL COMBI HINGE 40

Ausführung	nicht aushängbar	Model	<i>Non-detachable</i>
Beschreibung	für Flächenelemente und Aluminiumprofile	Description	<i>To hinge panels or aluminum profiles</i>
Material	Flügel: Edelstahl 1.4401 Achse: Edelstahl 1.4104	Material	<i>Wing: Stainless steel SS316 Axle: Stainless steel SS430 F</i>
Befestigung	vorderseitig mit Senkschrauben M6	Fastening	<i>From the front, using M6 countersunk screws</i>
Liefereinheit	10 Stück	Pack Quantity	<i>10 pieces</i>

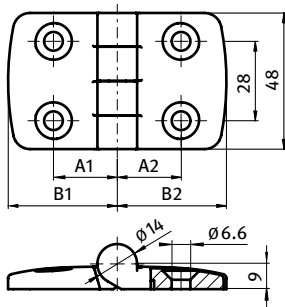

Kombischarnier <i>Combi Hinge</i>	A1 [mm]	A2 [mm]	B1 [mm]	B2 [mm]	F _{Amax} [N]	F _{Rmax} [N]	Bezeichnung <i>Description</i>	Gewicht [g] <i>Weight [g]</i>	Teil-Nr. <i>Part #</i>
nicht aushängbar <i>Non-detachable</i>	22.5	22.5	38.5	38.5	675	900	40/40	205.0	095E4040F

Scharniere Hinges

Edelstahlscharniere *Stainless Steel Hinges*

Kombischarniere *Combi Hinges*



EDELSTAHL-KOMBISCHARNIER 45

STAINLESS STEEL COMBI HINGE 45

Ausführung	aushängbar	Model	Detachable
Beschreibung	für Flächenelemente und Aluminiumprofile	Description	To hinge panels or aluminum profiles
Material	Flügel: Edelstahl 1.4401 Achse: Edelstahl 1.4104	Material	Wing: Stainless steel SS316 Axle: Stainless steel SS430 F
Befestigung	vorderseitig mit Senkschrauben M6	Fastening	From the front, using M6 countersunk screws
Liefereinheit	10 Stück	Pack Quantity	10 pieces

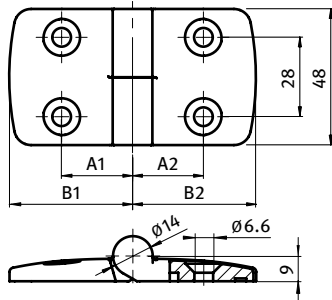

Kombischarnier Combi Hinge	A1 [mm]	A2 [mm]	B1 [mm]	B2 [mm]	F _{Amax} [N]	F _{Rmax} [N]	Bezeichnung Description	Gewicht [g] Weight [g]	Teil-Nr. Part #
L: links <i>Left</i>	25.0	25.0	42.5	42.5	450	1200	45/45	224.0	095E4545L
R: rechts <i>Right</i>	25.0	25.0	42.5	42.5	450	1200	45/45	224.0	095E4545R

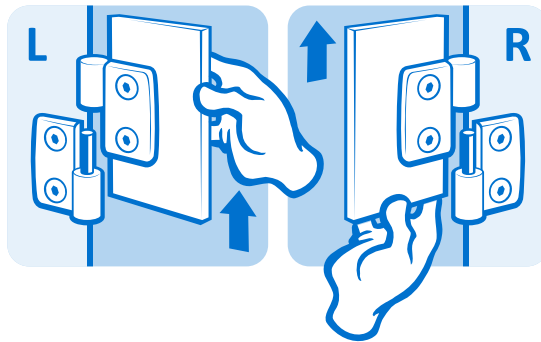

2

Scharniere Hinges

Edelstahlscharniere *Stainless Steel Hinges*

Kombischarniere *Combi Hinges*



EDELSTAHL-KOMBISCHARNIER 45

STAINLESS STEEL COMBI HINGE 45

Ausführung	nicht aushängbar	Model	<i>Non-detachable</i>
Beschreibung	für Flächenelemente und Aluminiumprofile	Description	<i>To hinge panels or aluminum profiles</i>
Material	Flügel: Edelstahl 1.4401 Achse: Edelstahl 1.4104	Material	<i>Wing: Stainless steel SS316 Axle: Stainless steel SS430 F</i>
Befestigung	vorderseitig mit Senkschrauben M6	Fastening	<i>From the front, using M6 countersunk screws</i>
Liefereinheit	10 Stück	Pack Quantity	<i>10 pieces</i>

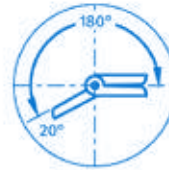
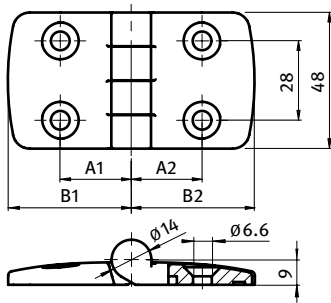

Kombischarnier <i>Combi Hinge</i>	A1 [mm]	A2 [mm]	B1 [mm]	B2 [mm]	F _{Amax} [N]	F _{Rmax} [N]	Bezeichnung <i>Description</i>	Gewicht [g] <i>Weight [g]</i>	Teil-Nr. <i>Part #</i>
nicht aushängbar <i>Non-detachable</i>	25.0	25.0	42.5	42.5	675	900	45/45	223.0	095E4545F

Scharniere Hinges

Edelstahlscharniere *Stainless Steel Hinges*

Kombischarniere *Combi Hinges*



EDELSTAHL-KOMBISCHARNIER 60

STAINLESS STEEL COMBI HINGE 60

Ausführung aushängbar	Model Detachable
Beschreibung für Flächenelemente und Aluminiumprofile	Description To hinge panels or aluminum profiles
Material Flügel: Edelstahl 1.4401 Achse: Edelstahl 1.4104	Material Wing: Stainless steel SS316 Axle: Stainless steel SS430 F
Befestigung vorderseitig mit Senkschrauben M6	Fastening From the front, using M6 countersunk screws
Liefereinheit 10 Stück	Pack Quantity 10 pieces

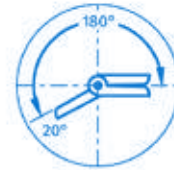
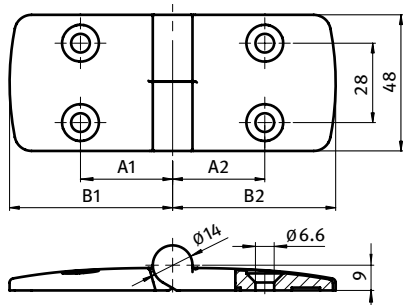

Kombischarnier Combi Hinge	A1 [mm]	A2 [mm]	B1 [mm]	B2 [mm]	F _{Amax} [N]	F _{Rmax} [N]	Bezeichnung Description	Gewicht [g] Weight [g]	Teil-Nr. Part #
L: links <i>Left</i>	32.5	32.5	56.5	56.5	350	1200	60/60	286.0	095E6060L
R: rechts <i>Right</i>	32.5	32.5	56.5	56.5	350	1200	60/60	286.0	095E6060R

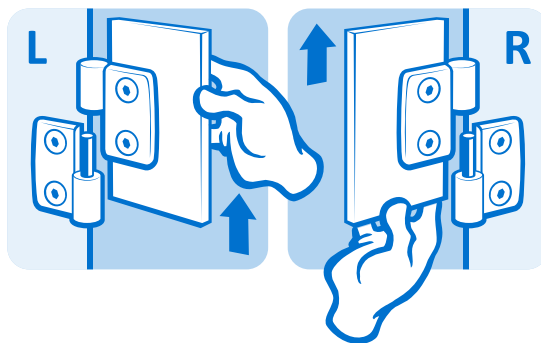

Scharniere Hinges

Edelstahlscharniere *Stainless Steel Hinges*

Kombischarniere *Combi Hinges*



EDELSTAHL-KOMBISCHARNIER 60

STAINLESS STEEL COMBI HINGE 60

Ausführung	nicht aushängbar	Model	<i>Non-detachable</i>
Beschreibung	für Flächenelemente und Aluminiumprofile	Description	<i>To hinge panels or aluminum profiles</i>
Material	Flügel: Edelstahl 1.4401 Achse: Edelstahl 1.4104	Material	<i>Wing: Stainless steel SS316 Axle: Stainless steel SS430 F</i>
Befestigung	vorderseitig mit Senkschrauben M6	Fastening	<i>From the front, using M6 countersunk screws</i>
Liefereinheit	10 Stück	Pack Quantity	<i>10 pieces</i>

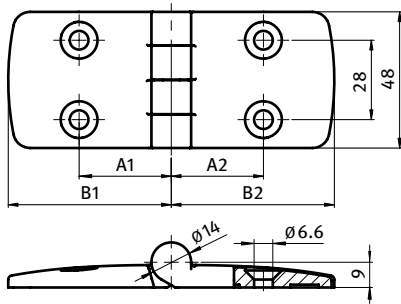

Kombischarnier <i>Combi Hinge</i>	A1 [mm]	A2 [mm]	B1 [mm]	B2 [mm]	F _{Amax} [N]	F _{Rmax} [N]	Bezeichnung <i>Description</i>	Gewicht [g] <i>Weight [g]</i>	Teil-Nr. <i>Part #</i>
nicht aushängbar <i>Non-detachable</i>	32.5	32.5	56.5	56.5	260	900	60/60	287.0	095E6060F

Scharniere Hinges

Edelstahlscharniere *Stainless Steel Hinges*



EDELSTAHLSCHARNIER LEICHT

LIGHT STAINLESS STEEL HINGE

Ausführung	nicht aushängbar	Model	Non-detachable
Beschreibung	für Flächenelemente und Aluminiumprofile	Description	To hinge panels or aluminum profiles
Material	Flügel: Edelstahl 1.4301 Achse: Edelstahl 1.4301	Material	Wing: Stainless steel 1.4301 Axle: Stainless steel 1.4301
Befestigung	vorderseitig mit Linsenkopfschrauben M4	Fastening	From the front, using M4 countersunk screws
Montageset	4 Linsenkopfschrauben ISO 7380 - M4 × 6, 4 Hammermütern M4 - Nut 6	Assembly Set	4 pan-head screws ISO 7380 - M4 × 6, 4 hammer nuts M4 - Nut 6
Liefereinheit	10 Stück	Pack Quantity	10 pieces

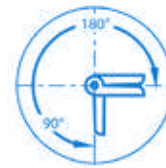
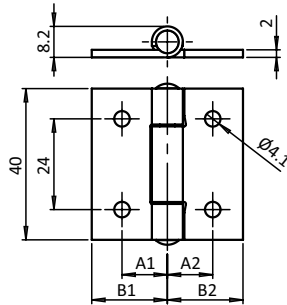

Edelstahlscharnier leicht <i>Light Stainless Steel Hinge</i>	A1 [mm]	A2 [mm]	B1 [mm]	B2 [mm]	F _{Amax} [N]	F _{Rmax} [N]	Gewicht [g] <i>Weight [g]</i>	Teil-Nr. <i>Part #</i>
	12.0	12.0	20.0	20.0	320.0	390.0	35.5	095072
inkl. Montageset <i>With assembly set</i>	12.0	12.0	20.0	20.0	320.0	390.0	45.0	095072S01

Scharniere Hinges

Edelstahlscharniere *Stainless Steel Hinges*



EDELSTAHLCHARNIER 40 × 40

STAINLESS STEEL HINGE 40 × 40

Ausführung	nicht aushängbar	Model	Non-detachable
Beschreibung	Scharnier für schwere Beanspruchung	Description	Hinge for heavy usage
Material	Flügel: Edelstahl 1.4401 Achse: Edelstahl 1.4401	Material	Wings: Stainless steel SS316 Axle: Stainless steel SS316
Befestigung	vorderseitig mit Senkschrauben	Fastening	From the front, using countersunk screws
Liefereinheit	10 Stück	Pack Quantity	10 pieces

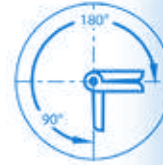
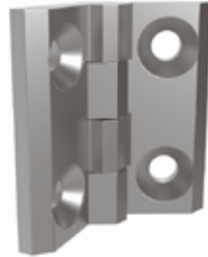
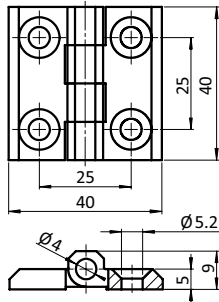

Edelstahlscharnier 40 × 40 <i>Stainless Steel Hinge 40 × 40</i>	F _{Amax} [N]	F _{Rmax} [N]	Gewicht [g] <i>Weight [g]</i>	Teil-Nr. <i>Part #</i>
	700	1200	61.00	09574040E

Scharniere Hinges

Edelstahlscharniere *Stainless Steel Hinges*



EDELSTAHLSCHARNIER 50 × 50

STAINLESS STEEL HINGE 50 × 50

Ausführung nicht aushängbar
Beschreibung Scharnier für schwere Beanspruchung
Material Flügel: Edelstahl 1.4401
 Achse: Edelstahl 1.4401
Befestigung vorderseitig mit Senkschrauben
Liefereinheit 10 Stück

Model Non-detachable
Description Hinge for heavy usage
Material Wings: Stainless steel SS316
 Axle: Stainless steel SS316
Fastening From the front, using countersunk screws
Pack Quantity 10 pieces

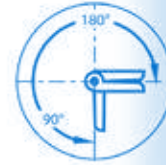
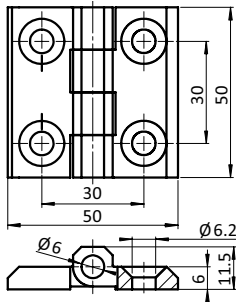

Edelstahlscharnier 50 × 50
 Stainless Steel Hinge 50 × 50

F_{Amax}
 [N]

F_{Rmax}
 [N]

Gewicht [g]
 Weight [g]

Teil-Nr.
 Part #

900

1600

95.00

09575050E

Scharniere Hinges

Edelstahlscharniere *Stainless Steel Hinges*



EDELSTAHLCHARNIER 50 × 63

STAINLESS STEEL HINGE 50 × 63

Ausführung	nicht aushängbar	Model	Non-detachable
Beschreibung	Scharnier für schwere Beanspruchung	Description	Hinge for heavy usage
Material	Flügel: Edelstahl 1.4401 Achse: Edelstahl 1.4401	Material	Wings: Stainless steel SS316 Axle: Stainless steel SS316
Befestigung	vorderseitig mit Senkschrauben	Fastening	From the front, using countersunk screws
Liefereinheit	10 Stück	Pack Quantity	10 pieces

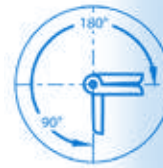
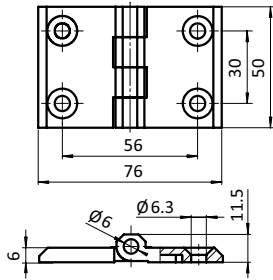

Edelstahlscharnier 50 × 63 <i>Stainless Steel Hinge 50 × 63</i>	F _{Amax} [N]	F _{Rmax} [N]	Gewicht [g] <i>Weight [g]</i>	Teil-Nr. <i>Part #</i>
	900	1600	122.00	095010E

2

Scharniere Hinges

Edelstahlscharniere *Stainless Steel Hinges*



EDELSTAHLCHARNIER 50 × 76

STAINLESS STEEL HINGE 50 × 76

Ausführung nicht aushängbar
Beschreibung Scharnier für schwere Beanspruchung
Material Flügel: Edelstahl 1.4401
 Achse: Edelstahl 1.4401
Befestigung vorderseitig mit Senkschrauben
Liefereinheit 10 Stück

Model Non-detachable
Description Hinge for heavy usage
Material Wings: Stainless steel SS316
 Axle: Stainless steel SS316
Fastening From the front, using countersunk screws
Pack Quantity 10 pieces

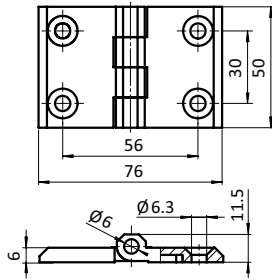

Edelstahlscharnier 50 × 76
 Stainless Steel Hinge 50 × 76

F_{Amax}
 [N]

F_{Rmax}
 [N]

Gewicht [g]
 Weight [g]

Teil-Nr.
 Part #

550

1000

146.00

095007E

Scharniere Hinges

Edelstahlscharniere *Stainless Steel Hinges*



EDELSTAHLCHARNIER 60 × 60

STAINLESS STEEL HINGE 60 × 60

Ausführung	nicht aushängbar	Model	Non-detachable
Beschreibung	Scharnier für schwere Beanspruchung	Description	Hinge for heavy usage
Material	Flügel: Edelstahl 1.4401 Achse: Edelstahl 1.4401	Material	Wings: Stainless steel SS316 Axle: Stainless steel SS316
Befestigung	vorderseitig mit Senkschrauben	Fastening	From the front, using countersunk screws
Liefereinheit	10 Stück	Pack Quantity	10 pieces

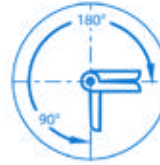
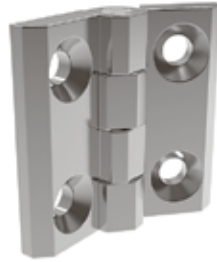
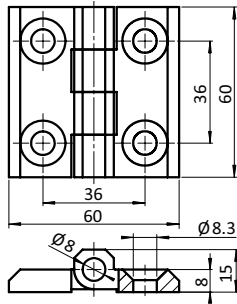

Edelstahlscharnier 60 × 60 <i>Stainless Steel Hinge 60 × 60</i>	F _{Amax} [N]	F _{Rmax} [N]	Gewicht [g] <i>Weight [g]</i>	Teil-Nr. <i>Part #</i>
	1200	2000	222.00	09576060E

Scharniere Hinges

Edelstahlscharniere *Stainless Steel Hinges*



EDELSTAHLSCHARNIER LR

STAINLESS STEEL HINGE LR

<p>Ausführung aushängbar, Anwendung rechts und links</p> <p>Beschreibung doppelt symmetrisches Scharnier für die Anwendung links oder rechts</p> <p>Material Flügel: Edelstahl 1.4401 Achse: Edelstahl 1.4401</p> <p>Befestigung vorderseitig mit Senkschrauben M6</p> <p>Liefereinheit 10 Stück</p>	<p>Model Detachable, right and left application</p> <p>Description Dual symmetrical layout enables right and left hand application</p> <p>Material Wings: Stainless steel SS316 Axle: Stainless steel SS316</p> <p>Fastening From the front, using M6 countersunk screws</p> <p>Pack Quantity 10 pieces</p>
---	--

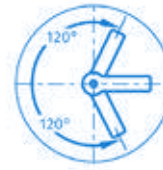
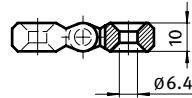
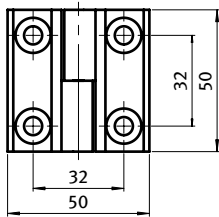







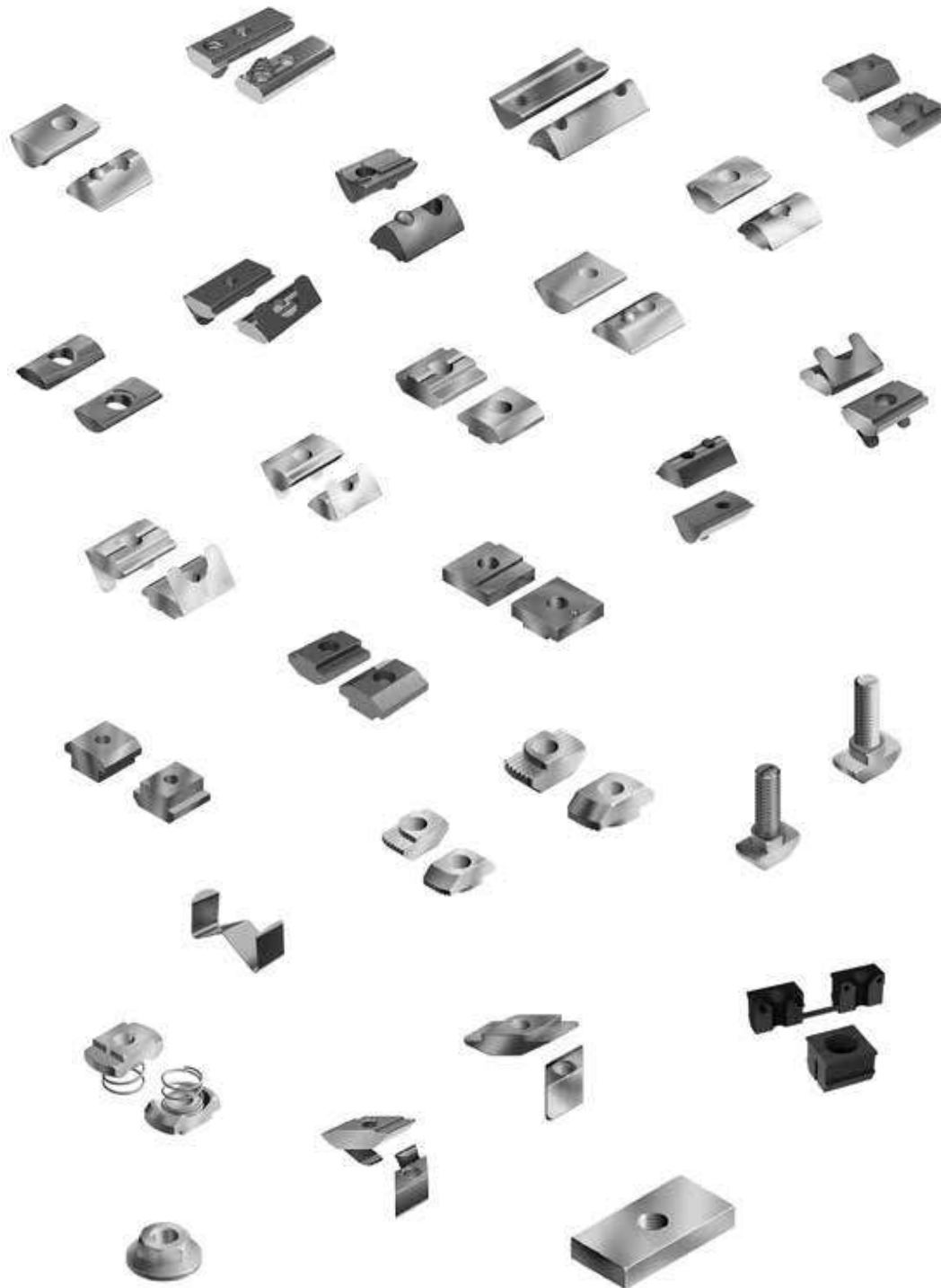































Edelstahlscharnier <i>Stainless Steel Hinge</i>	F _{Amax} [N]	F _{Rmax} [N]	Gewicht [g] <i>Weight [g]</i>	Teil-Nr. <i>Part #</i>
	600	1000	156.0	09575050ELR





































2

INHALTSÜBERSICHT *CONTENT OVERVIEW*



Bodenelemente <i>Floor Elements</i>	1
Scharniere <i>Hinges</i>	2
Nutmuttern und -schrauben <i>T-Nuts and T-Bolts</i>	3
Verbindungstechnik <i>Connecting Systems</i>	4
Griffe und Verschlüsse <i>Handles and Latches</i>	5
Arbeitsplatzkomponenten <i>Components for Work Stations</i>	6
Gleiter und Rollen <i>Sliders and Rollers</i>	7
Fördertechnik <i>Conveyors</i>	8
Schutz- und Trennwandelemente <i>Enclosures, Guards, Partitions</i>	9
Flächenbefestigungen <i>Panel Fasteners</i>	10
Abdeckelemente <i>Cover Elements</i>	11
Kabelführungen <i>Cable Management</i>	12
Diverse Komponenten <i>Miscellaneous Components</i>	13
Rundrohrkomponenten <i>Tubular Frame Components</i>	14

	Nutenstein 7,1 × 4,3 mm, einschwenkbar	<i>Roll-in T-slot Nut</i> 7.1 × 4.3 mm	236		Nutenstein 12,0 × 7,2 mm, einschwenkbar	<i>Roll-in T-slot Nut</i> 12.0 × 7.2 mm	255
	Nutenstein 7,7 × 4,0 mm, einschwenkbar	<i>Roll-in T-slot Nut</i> 7.7 × 4.0 mm	237		Nutenstein 12,5 × 6,0 mm, einschwenkbar	<i>Roll-in T-slot Nut</i> 12.5 × 6.0 mm	256
	Nutenstein 8,0 × 4,2 mm, einschwenkbar	<i>Roll-in T-slot Nut</i> 8.0 × 4.2 mm	238		Nutenstein 12,5 × 6,0 mm, einschwenkbar	<i>Roll-in T-slot Nut</i> 12.5 × 6.0 mm	257
	Nutenstein 8,0 × 4,7 mm, einschwenkbar	<i>Roll-in T-slot Nut</i> 8.0 × 4.7 mm	239		Nutenstein 12,9 × 7,2 mm, einschwenkbar	<i>Roll-in T-slot Nut</i> 12.9 × 7.2 mm	258
	Nutenstein 7,7 × 3,4 mm, einschwenkbar	<i>Roll-in T-slot Nut</i> 7.7 × 3.4 mm	240		Nutenstein 13,0 × 10,0 mm, einschwenkbar	<i>Roll-in T-slot Nut</i> 13.0 × 10.0 mm	259
	Nutenstein 10,5 × 6,3 mm, einschwenkbar	<i>Roll-in T-slot Nut</i> 10.5 × 6.3 mm	241		Nutenstein 13,4 × 7,6 mm, einschwenkbar	<i>Roll-in T-slot Nut</i> 13.4 × 7.6 mm	260
	Nutenstein 10,5 × 6,9 mm, einschwenkbar	<i>Roll-in T-slot Nut</i> 10.5 × 6.9 mm	242		Nutenstein 13,5 × 7,2 mm, einschwenkbar	<i>Roll-in T-slot Nut</i> 13.5 × 7.2 mm	261
	DoppelNutenstein 10,5 × 6,9 mm, einschwenkbar	<i>Roll-in Double T-slot Nut</i> 10.5 × 6.9 mm	243		Nutenstein 13,5 × 7,2 mm, einschwenkbar	<i>Roll-in T-slot Nut</i> 13.5 × 7.2 mm	262
	DoppelNutenstein 10,5 × 6,3 mm, einschwenkbar	<i>Roll-in Double T-slot Nut</i> 10.5 × 6.3 mm	244		Nutenstein 13,7 × 7,0 mm, einschwenkbar	<i>Roll-in T-slot Nut</i> 13.7 × 7.0 mm	263
	Nutenstein 11,0 × 5,5 mm, einschwenkbar	<i>Roll-in T-slot Nut</i> 11.0 × 5.5 mm	245		Nutenstein 16,0 × 6,0 mm	<i>T-slot Nut</i> 16.0 × 6.0 mm	264
	Nutenstein 11,0 × 5,5 mm, einschwenkbar	<i>Roll-in T-slot Nut</i> 11.0 × 5.5 mm	246		Nutenstein 17,0 × 8,0 mm	<i>T-slot Nut</i> 17.0 × 8.0 mm	265
	Nutenstein 9,8 × 4,5 mm	<i>T-slot Nut</i> 9.8 × 4.5 mm	247		Nutenstein 17,0 × 9,6 mm	<i>T-slot Nut</i> 17.0 × 9.6 mm	266
	Nutenstein 11,0 × 4,0 mm	<i>T-slot Nut</i> 11.0 × 4.0 mm	248		Nutenstein 18,0 × 6,8 mm	<i>T-slot Nut</i> 18.0 × 6.8 mm	267
	Nutenstein 10,15 × 5,0 mm, einschwenkbar	<i>Roll-in T-slot Nut</i> 10.15 × 5.0 mm	249		Nutenstein 18,0 × 12,2 mm	<i>T-slot Nut</i> 18.0 × 12.2 mm	268
	Nutenstein 10,8 × 4,1 mm, einschwenkbar	<i>Roll-in T-slot Nut</i> 10.8 × 4.1 mm	250		Nutenstein 14,0 × 5,2 mm, einschwenkbar	<i>Roll-in T-slot Nut</i> 14.0 × 5.2 mm	269
	Nutenstein 10,8 × 4,1 mm, einschwenkbar	<i>Roll-in T-slot Nut</i> 10.8 × 4.1 mm	251		Nutenstein 14,0 × 5,2 mm, einschwenkbar	<i>Roll-in T-slot Nut</i> 14.0 × 5.2 mm	270
	Nutenstein 11,0 × 4,1 mm, einschwenkbar	<i>Roll-in T-slot Nut</i> 11.0 × 4.1 mm	252		Nutenstein 14,5 × 6,2 mm, einschwenkbar	<i>Roll-in T-slot Nut</i> 14.5 × 6.2 mm	271
	Nutenstein 11,6 × 4,6 mm, einschwenkbar	<i>Roll-in T-slot Nut</i> 11.6 × 4.6 mm	253		Nutenstein 14,5 × 10,9 mm, einschwenkbar	<i>Roll-in T-slot Nut</i> 14.5 × 10.9 mm	272
	Nutenstein 11,6 × 4,6 mm, einschwenkbar	<i>Roll-in T-slot Nut</i> 11.6 × 4.6 mm	254		Nutenstein 15,0 × 6,0 mm, einschwenkbar	<i>Roll-in T-slot Nut</i> 15.0 × 6.0 mm	273

	Nutenstein 15,0 × 6,0 mm, einschwenkbar	<i>Roll-in T-slot Nut</i> 15.0 × 6.0 mm	274		Hammermutter	<i>Hammer Nut</i>	294
	Nutenstein 13,0 × 5,0 mm	<i>T-slot Nut</i> 13.0 × 5.0 mm	275		Hammermutter	<i>Hammer Nut</i>	295
	Nutenstein 15,0 × 8,0 mm	<i>T-slot Nut</i> 15.0 × 8.0 mm	276		Hammermutter	<i>Hammer Nut</i>	296
	Nutenstein 18,0 × 5,5 mm	<i>T-slot Nut</i> 18.0 × 5.5 mm	277		Hammermutter	<i>Hammer Nut</i>	297
	Nutenstein 18,0 × 7,5 mm	<i>T-slot Nut</i> 18.0 × 7.5 mm	278		Hammerschraube	<i>Hammer Head Screw</i>	298
	Nutenstein 18,0 × 8,0 mm	<i>T-slot Nut</i> 18.0 × 8.0 mm	279		Hammerschraube	<i>Hammer Head Screw</i>	299
	Nutenstein 19,5 × 10,6 mm	<i>T-slot Nut</i> 19.5 × 10.6 mm	280		Hammerschraube	<i>Hammer Head Screw</i>	300
	Nutenstein 19,5 × 10,6 mm	<i>T-slot Nut</i> 19.5 × 10.6 mm	281		Flanschmutter	<i>Flange Nut</i>	301
	Nutenstein 19,5 × 10,6 mm	<i>T-slot Nut</i> 19.5 × 10.6 mm	282		Federmutter	<i>Spring Nut</i>	302
	Nutenstein 19,5 × 10,6 mm	<i>T-slot Nut</i> 19.5 × 10.6 mm	283		Federmutter	<i>Spring Nut</i>	303
	Nutenstein 20,0 × 6,4 mm	<i>T-slot Nut</i> 20.0 × 6.4 mm	284		Rhombus-Nutenstein	<i>Rhombus T-Slot Nut</i>	304
	Nutenstein 20,0 × 6,4 mm	<i>T-slot Nut</i> 20.0 × 6.4 mm	285		Rhombus-Nutenstein	<i>Rhombus T-Slot Nut</i>	305
	Nutenstein 13,1 × 5,3 mm, einschwenkbar	<i>Roll-in-T-slot Nut</i> 13.1 × 5.3 mm	286		Rhombusmutter	<i>Rhombus Nut</i>	306
	Nutenstein 16,4 × 7,0 mm, einschwenkbar	<i>Roll-in-T-slot Nut</i> 16.4 × 7.0 mm	287		Rhombusmutter	<i>Rhombus Nut</i>	307
	Nutenstein 20,0 × 10,0 mm, einschwenkbar	<i>Roll-in-T-slot Nut</i> 20.0 × 10.0 mm	288		Gewindeplatte	<i>Threaded Plate</i>	308
	Nutenstein 20,3 × 11,2 mm, einschwenkbar	<i>Roll-in-T-slot Nut</i> 20.3 × 11.2 mm	289		Gewindeplatte	<i>Threaded Plate</i>	309
	Nutenstein 20,0 × 9,0 mm	<i>T-slot Nut</i> 20.0 × 9.0 mm	290		Gewindeplatte Rhombus	<i>Threaded Plate Rhombus</i>	310
	Feder für Nutenstein	<i>Spring for T-slot Nut</i>	291		Spreizmutter	<i>Spread Nut</i>	311
	Hammermutter	<i>Hammer Nut</i>	293				

NUTENSTEINE

Dieses Kapitel enthält neben Nutensteinen mit und ohne Fixierung auch Hammer- und Rhombusmuttern und einen typischen Ausschnitt aus unserem Gewindeplatten-Programm.

Gerade beim Thema Gewindeplatten lohnt es sich, wenn Sie direkt Kontakt mit uns aufnehmen: wir fertigen sie auf Wunsch und nach Maß – auch in Edelstahl. Wenn Sie also in der Tabelle nicht finden, was Sie brauchen: rufen Sie einfach an!

Symbole

Um für Sie die Suche nach dem richtige Nutenstein so einfach wie möglich zu machen, verwenden wir die folgenden Symbole:

Nutbreite

Die Zahl gibt in Millimetern an, für welche Nutbreite der Nutenstein vorgesehen ist.

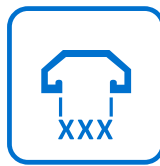

Slot size

The number indicates the slot width in mm of the slot for which the T-slot nut is intended.

Nutenstein einschiebbar

Dieses Symbol zeigt, dass der Nutenstein von der Stirnseite her in die Profilmutter eingeschoben werden muss. Die Alternative ist der einschwenkbare Nutenstein.

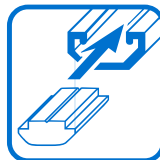

Regular T-slot Nut

This symbol shows that the T-slot nut is inserted into the slot from the top or the bottom of the profile. The alternative is a roll-in T-slot nut.

Nutenstein einschwenkbar

Dieses Symbol gibt an, dass der Nutenstein in die Nut eingeschwenkt werden kann – zum Beispiel in eine fertig montierte Profilstruktur

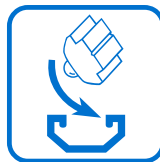

Roll-in T-slot Nut

This symbol indicates that the T-slot nut can be rolled into the slot of the profile, which is especially useful when you want to insert the T-slot nut into an existing structure.

Fixierung

Um die Montage zu erleichtern, fixiert sich der Nutenstein mittels Federblech oder Federkugel in der Nut. Das erkennen Sie an diesem Symbol.

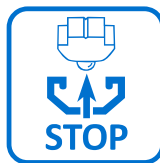

Fixation

To facilitate assembly, some T-slot nuts come with fixation elements such as a spring loaded ball or a spring leaf, allowing them to stay in place. You can recognize them by this symbol.

Maßtoleranzen

$L = \pm 1 \text{ mm}$
 $L1 = \pm 0,2 \text{ mm}$
 $B = \pm 0,2 \text{ mm}$
 $H = \pm 0,2 \text{ mm}$
 $H1 = \pm 0,2 \text{ mm}$
 $H2 = \pm 0,1 \text{ mm}$
 $B1 = \pm 0,3 \text{ mm}$

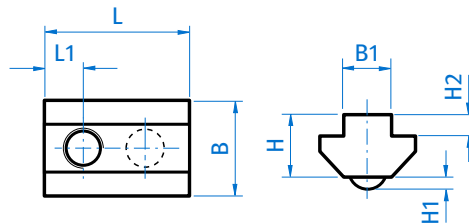

Dimensional Tolerances

$L = \pm 1 \text{ mm}$
 $L1 = \pm 0.2 \text{ mm}$
 $B = \pm 0.2 \text{ mm}$
 $H = \pm 0.2 \text{ mm}$
 $H1 = \pm 0.2 \text{ mm}$
 $H2 = \pm 0.1 \text{ mm}$
 $B1 = \pm 0.3 \text{ mm}$

Alle Angaben dienen Ihrer Information und stellen keine rechtsverbindliche Zusicherung von Eigenschaften dar.

All information is just for reference and does not pose a legally binding agreement about the product properties.

Nutmuttern und -schrauben *T-Nuts and T-Bolts*

Nutensteine *T-slot Nuts*

Nut 5 *Slot 5*



NUTENSTEIN 7,1 × 4,3 MM, EINSCHWENKBAR

ROLL-IN T-SLOT NUT 7.1 × 4.3 MM

Ausführung	Nut 5, mit Führungssteg und Federkugel, Stahl	Model	Slot 5, self-aligning with spring loaded ball, steel
Beschreibung	einschwenkbarer Nutenstein mit Führungssteg und Federkugel	Description	Self-aligning roll-in T-slot nut with spring loaded ball
Material	Nutenstein: Stahl, verzinkt Kugel: Edelstahl	Material	T-slot nut: Zinc plated steel Ball: Stainless steel
Liefereinheit	100 Stück	Pack Quantity	100 pieces

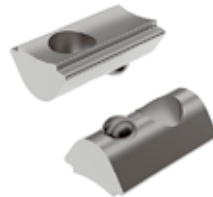
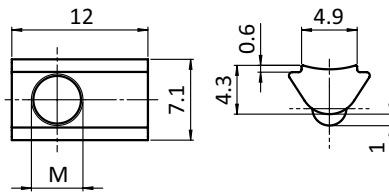

Nutenstein T-slot Nut	Größe Size	Gewicht [g] Weight [g]	Profil Profile	Teil-Nr. Part #
	M3	1.4	I	096523
	M4	1.6	I	096524
	M5	1.8	I	096525

Nutmuttern und -schrauben *T-Nuts and T-Bolts*

Nutensteine *T-slot Nuts*

Nut 5 *Slot 5*



NUTENSTEIN 7,7 × 4,0 MM, EINSCHWENKBAR

ROLL-IN T-SLOT NUT 7.7 × 4.0 MM

Ausführung Nut 5, mit Führungssteg und Federkugel, Stahl
Beschreibung einschwenkbarer Nutenstein mit Führungssteg und Federkugel
Material Nutenstein: Stahl, verzinkt
 Profil: Stahl, blank, ohne Gewinde
 Kugel: Edelstahl
Liefereinheit 100 Stück
Extras ⚡elektrostatisch entladend, verschiedene Längen mit mehreren Gewinden in unterschiedlichen Größen auf Anfrage

Model Slot 5, self-aligning with spring loaded ball, steel
Description Self-aligning roll-in T-slot nut with spring loaded ball
Material T-slot nut: Zinc plated steel
 Rod: Steel, plain, without thread
 Ball: Stainless steel
Pack Quantity 100 pieces
Specials ⚡electrostatically discharging, different lengths with multiple threads in different sizes available on request

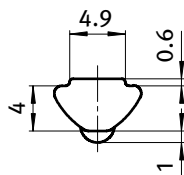
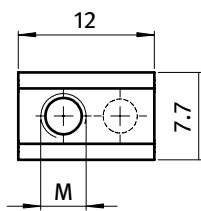

Nutenstein T-slot Nut	Größe Size	Gewicht [g] Weight [g]	Profil Profile	Teil-Nr. Part #
	M3	2.2	I	096213
	M4	2.0	I	096214
	M5	1.8	I	096215
Profil Rod	1500 mm	309.0	I	096210.1500

Nutmuttern und -schrauben *T-Nuts and T-Bolts*

Nutensteine *T-slot Nuts*

Nut 5 *Slot 5*



NUTENSTEIN 8,0 × 4,2 MM, EINSCHWENKBAR

ROLL-IN T-SLOT NUT 8.0 × 4.2 MM

Ausführung	Nut 5, mit Federkugel, Stahl / Edelstahl	Model	Slot 5, with spring loaded ball, steel / stainless steel
Beschreibung	einschwenkbarer Nutenstein mit Federkugel	Description	Roll-in T-slot nut with spring loaded ball
Material	Nutenstein: Stahl, verzinkt / Edelstahl 1.4301 / 1.4305 Profil: Stahl, blank, ohne Gewinde Kugel: Edelstahl	Material	T-slot nut: Zinc plated steel / stainless steel SS304 / SS303 Rod: Steel, plain, without thread Ball: Stainless steel
Liefereinheit	100 Stück	Pack Quantity	100 pieces
Extras	⚡ elektrostatisch entladend, verschiedene Längen mit mehreren Gewinden in unterschiedlichen Größen auf Anfrage	Specials	⚡ electrostatically discharging, different lengths with multiple threads in different sizes available on request

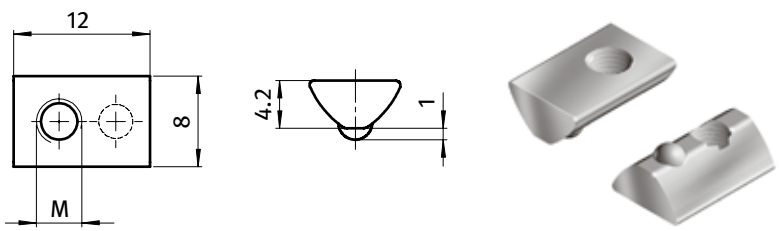

Nutenstein <i>T-slot Nut</i>	Größe <i>Size</i>	Gewicht [g] <i>Weight [g]</i>	Profil <i>Profile</i>	Teil-Nr. <i>Part #</i>
Stahl <i>Steel</i>	M3	2.0	I	096203
	M4	1.8	I	096204
	M5	1.6	I	096205
Edelstahl <i>Stainless steel</i>	M4	1.8	I	096204E
	M5	1.6	I	096205E
Profil, Stahl <i>Rod, steel</i>	1500 mm	309.0	I	096200.1500

Nutmuttern und -schrauben *T-Nuts and T-Bolts*

Nutensteine *T-slot Nuts*

Nut 5 *Slot 5*



NUTENSTEIN 8,0 × 4,7 MM, EINSCHWENKBAR

ROLL-IN T-SLOT NUT 8.0 × 4.7 MM

Ausführung Nut 5, mit Führungssteg und Federkugel, Stahl
Beschreibung einschwenkbarer Nutenstein mit Führungssteg und Federkugel
Material Nutenstein: Stahl, verzinkt
 Kugel: Edelstahl
Liefereinheit 100 Stück
Extras elektrostatisch entladend, verschiedene Längen mit mehreren Gewinden in unterschiedlichen Größen auf Anfrage

Model Slot 5, self-aligning with spring loaded ball, steel
Description Self-aligning roll-in T-slot nut with spring loaded ball
Material T-slot nut: Zinc plated steel
 Ball: Stainless steel
Pack Quantity 100 pieces
Specials electrostatically discharging, different lengths with multiple threads in different sizes available on request

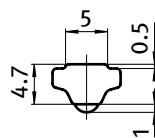
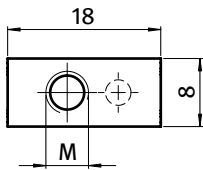

Nutenstein
T-slot Nut

Größe
Size

Gewicht [g]
Weight [g]

Teil-Nr.
Part #

M4

3.4

096264

M5

3.2

096265

Nutmuttern und -schrauben *T-Nuts and T-Bolts*

Nutensteine *T-slot Nuts*

Nut 6 *Slot 6*



NUTENSTEIN 7,7 × 3,4 MM, EINSCHWENKBAR

ROLL-IN T-SLOT NUT 7.7 × 3.4 MM

Ausführung	Nut 6, mit Führungssteg und Druckfeder Stahl	Model	Slot 6, self-aligning with spiral spring, steel
Beschreibung	einschwenkbarer Nutenstein mit Führungssteg und Druckfeder	Description	Self-aligning roll-in T-slot nut with spiral spring
Material	Stahl	Material	Steel
Liefereinheit	100 Stück	Pack Quantity	100 pieces
Extras	verschiedene Längen mit mehreren Gewinden in unterschiedlichen Größen auf Anfrage	Specials	Different lengths with multiple threads in different sizes available on request

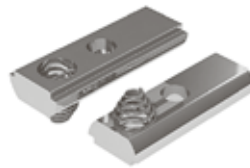
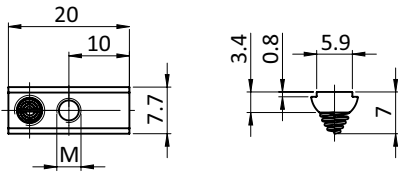

Nutenstein T-slot Nut	Größe Size	Gewicht [g] Weight [g]	Profil Profile	Teil-Nr. Part #
	M4	2.6	B	096244F
	M5	2.4	B	096245F

Nutmuttern und -schrauben *T-Nuts and T-Bolts*

Nutensteine *T-slot Nuts*

Nut 6 *Slot 6*



NUTENSTEIN 10,5 × 6,3 MM, EINSCHWENKBAR

ROLL-IN T-SLOT NUT 10.5 × 6.3 MM

Ausführung	Nut 6, mit Federkugel, Stahl / Edelstahl	Model	Slot 6, with spring loaded ball, Steel / stainless steel
Beschreibung	einschwenkbarer Nutenstein mit Federkugel	Description	Roll-in T-slot nut with spring loaded ball
Material	Nutenstein: Stahl, verzinkt / Edelstahl 1.4301 / 1.4305 Profil: Stahl, blank, ohne Gewinde Kugel: Edelstahl	Material	T-slot nut: Zinc plated steel / stainless steel SS304 / SS303 Rod: Steel, plain, without thread Ball: Stainless steel
Liefereinheit	100 Stück	Pack Quantity	100 pieces
Extras	⚡ elektrostatisch entladend, verschiedene Längen mit mehreren Gewinden in unterschiedlichen Größen auf Anfrage	Specials	⚡ electrostatically discharging, different lengths with multiple threads in different sizes available on request

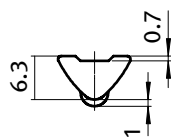
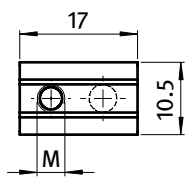

Nutenstein T-slot Nut	ESD	Größe Size	Gewicht [g] Weight [g]	Profil Profile	Teil-Nr Part#
Stahl <i>Steel</i>		M3	5.2	I	096233
		M4	5.0	I	096234
		M5	4.8	I	096235
		M6	4.5	I	096236
Edelstahl <i>Stainless steel</i>		M5	4.8	I	096235E
		M6	4.5	I	096236E
Stahl <i>Steel</i>	elektrostatisch entladend ⚡ <i>electrostatically discharging</i>	M5	4.8	I	096235S01
Profil Stahl <i>Rod, steel</i>		1500 mm	465.0	I	096230.1500



Nutmuttern und -schrauben *T-Nuts and T-Bolts*

Nutensteine *T-slot Nuts*

Nut 6 *Slot 6*



NUTENSTEIN 10,5 × 6,9 MM, EINSCHWENKBAR

ROLL-IN T-SLOT NUT 10.5 × 6.9 MM

Ausführung	Nut 6, mit Führungssteg und Federkugel, Stahl	Model	Slot 6, with spring loaded ball, steel
Beschreibung	einschwenkbarer Nutenstein mit Führungssteg und Federkugel	Description	Self-aligning roll-in T-slot nut with spring loaded ball
Material	Nutenstein: Stahl, verzinkt Profil: Stahl, blank, ohne Gewinde Kugel: Edelstahl	Material	T-slot nut: Zinc plated steel Rod: Steel, plain, without thread Ball: Stainless steel
Liefereinheit	100 Stück	Pack Quantity	100 pieces
Extras	⚡ elektrostatisch entladend, verschiedene Längen mit mehreren Gewinden in unterschiedlichen Größen auf Anfrage	Specials	⚡ electrostatically discharging, different lengths with multiple threads in different sizes available on request

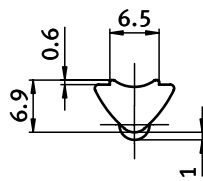
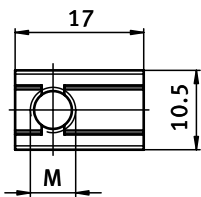

Nutenstein T-slot Nut	Größe Size	Gewicht [g] Weight [g]	Profil Profile	Teil-Nr. Part #
	M3	5.5	I	096553
	M4	5.3	I	096554
	M5	4.5	I	096555
	M6	4.6	I	096556
Profil, Stahl <i>Rod, steel</i>	1500 mm	525.0	I	096550.1500

Nutmuttern und -schrauben *T-Nuts and T-Bolts*

Nutensteine *T-slot Nuts*

Nut 6 *Slot 6*



DOPPELNUTENSTEIN 10,5 × 6,9 MM, EINSCHWENKBAR *ROLL-IN DOUBLE T-SLOT NUT 10.5 × 6.9 MM*

Ausführung	Nut 6, Stahl	Model	Slot 6, steel
Beschreibung	einschwenkbarer Doppelnutenstein	Description	Roll-in double T-slot nut
Material	Stahl, verzinkt	Material	Zinc plated steel
Liefereinheit	100 Stück	Pack Quantity	100 pieces
Extras	verschiedene Längen mit mehreren Gewinden in unterschiedlichen Größen auf Anfrage	Specials	Different lengths with multiple threads in different sizes available on request

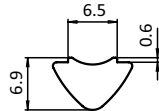
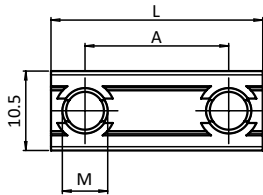

Doppelnutenstein <i>Double T-slot Nut</i>	A [mm]	L [mm]	Größe <i>Size</i>	Gewicht [g] <i>Weight [g]</i>	Profil <i>Profile</i>	Teil-Nr. <i>Part #</i>
	19.0	28.0	M5	8.5	I	096555D28
	49.0	58.0	M5	19.0	I	096555D58
	17.0	28.0	M6	7.9	I	096556D28
	47.0	58.0	M6	18.4	I	096556D58

3

Nutmuttern und -schrauben *T-Nuts and T-Bolts*

Nutensteine *T-slot Nuts*

Nut 6 *Slot 6*



DOPPELNUTENSTEIN 10,5 × 6,3 MM, EINSCHWENKBAR *ROLL-IN DOUBLE T-SLOT NUT 10.5 × 6.3 MM*

Ausführung	Nut 6, Stahl	Model	Slot 6, steel
Beschreibung	einschwenkbarer Doppelnutenstein; elektrostatisch entladende Ausführung mit zwei Kerben auf einer Stirnseite	Description	Roll-in Double T-slot nut; electrostatically discharging version with two notches on one front end
Material	Stahl, verzinkt	Material	Zinc plated steel
Liefereinheit	100 Stück	Pack Quantity	100 pieces
Extras	verschiedene Längen mit mehreren Gewinden in unterschiedlichen Größen auf Anfrage	Specials	Different lengths with multiple threads in different sizes available on request

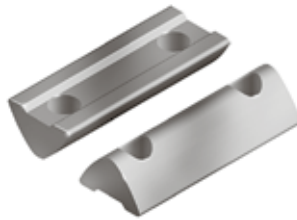
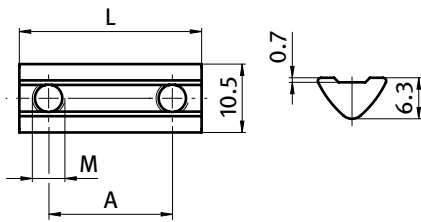

Doppelnutenstein <i>Double T-slot Nut</i>	A [mm]	L [mm]	Größe Size	Gewicht [g] Weight [g]	Profil Profile	Teil-Nr Part#
	19.0	28.0	M5	7.2	I	096235D28
	49.0	58.0	M5	17.0	I	096235D58
	17.0	28.0	M6	6.0	I	096236D28
	47.0	58.0	M6	16.0	I	096236D58
elektrostatisch entladend <i>electrostatically discharging</i>	19.0	28.0	M5	7.2	I	096235D28S01
	49.0	58.0	M5	17.0	I	096235D58S01

Nutmuttern und -schrauben *T-Nuts and T-Bolts*

Nutensteine *T-slot Nuts*

Nut 6 *Slot 6*



NUTENSTEIN 11,0 × 5,5 MM, EINSCHWENKBAR

ROLL-IN T-SLOT NUT 11.0 × 5.5 MM

Ausführung	Nut 6, mit Führungssteg, Stahl	Model	Slot 6, self-aligning, steel
Beschreibung	einschwenkbarer Nutenstein mit Führungssteg	Description	Self-aligning roll-in T-slot nut
Material	Nutenstein: Stahl, verzinkt Profil: Stahl, blank, ohne Gewinde	Material	T-slot nut: Zinc plated steel Rod: Steel, plain, without thread
Liefereinheit	100 Stück	Pack Quantity	100 pieces
Extras	⚡ elektrostatisch entladend, verschiedene Längen mit mehreren Gewinden in unterschiedlichen Größen auf Anfrage	Specials	⚡ electrostatically discharging, different lengths with multiple threads in different sizes available on request

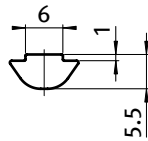
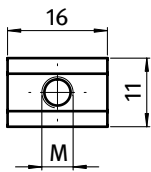

Nutenstein T-slot Nut	Größe Size	Gewicht [g] Weight [g]	Teil-Nr. Part #
	M4	5.6	096284
	M5	5.5	096285
	M6	5.2	096286
Profil Rod	1500 mm	497.0	096280.1500



Nutmuttern und -schrauben *T-Nuts and T-Bolts*

Nutensteine *T-slot Nuts*

Nut 6 *Slot 6*



NUTENSTEIN 11,0 × 5,5 MM, EINSCHWENKBAR

ROLL-IN T-SLOT NUT 11.0 × 5.5 MM

Ausführung Nut 6, mit Führungssteg und Federblech, Stahl
Beschreibung einschwenkbarer Nutenstein mit Führungssteg und Federblech
Material Stahl, verzinkt
Liefereinheit 100 Stück
Extras ⚡ elektrostatisch entladend, verschiedene Längen mit mehreren Gewinden in unterschiedlichen Größen auf Anfrage

Model Slot 6, self-aligning with spring leaf, steel
Description Self-aligning roll-in T-slot nut with spring leaf
Material Zinc plated steel
Pack Quantity 100 pieces
Specials ⚡ electrostatically discharging, different lengths with multiple threads in different sizes available on request

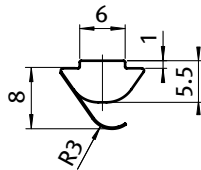
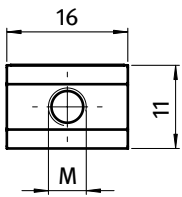

Nutenstein
T-slot Nut

Größe
Size

Gewicht [g]
Weight [g]

Teil-Nr.
Part #

	M4	5.6	096284F
	M5	5.5	096285F
	M6	5.2	096286F

Nutmuttern und -schrauben *T-Nuts and T-Bolts*

Nutensteine *T-slot Nuts*

Nut 6 *Slot 6*



NUTENSTEIN 9,8 × 4,5 MM

T-SLOT NUT 9.8 × 4.5 MM

Ausführung Nut 6, mit Führungssteg, Stahl

Beschreibung Nutenstein mit Führungssteg

Material Stahl, verzinkt

Liefereinheit 100 Stück

Extras elektrostatisch entladend, verschiedene Längen mit mehreren Gewinden in unterschiedlichen Größen auf Anfrage

Model Slot 6, self-aligning, steel

Description Self-aligning T-slot nut

Material Zinc plated steel

Pack Quantity 100 pieces

Specials electrostatically discharging, different lengths with multiple threads in different sizes available on request

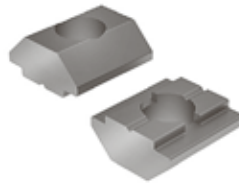
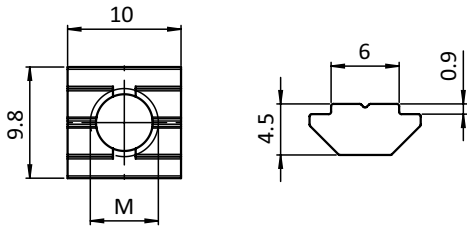

Nutenstein <i>T-slot Nut</i>	Größe <i>Size</i>	Gewicht [g] <i>Weight [g]</i>	Profil <i>Profile</i>	Teil-Nr. <i>Part #</i>
	M4	2.4	B	096504
	M5	2.2	B	096505
	M6	1.9	B	096506

Nutmuttern und -schrauben *T-Nuts and T-Bolts*

Nutensteine *T-slot Nuts*

Nut 6 Slot 6



NUTENSTEIN 11,0 × 4,0 MM

T-SLOT NUT 11.0 × 4.0 MM

Ausführung	Nut 6, mit Führungssteg, Edelstahl	Model	Slot 6, self-aligning, stainless steel
Beschreibung	Nutenstein mit Führungssteg, ⚡ elektrostatisch entladend	Description	Self-aligning T-slot nut, ⚡ electrostatically discharging
Material	Edelstahl 1.4301 / 1.4305	Material	Stainless steel SS304 / SS303
Liefereinheit	100 Stück	Pack Quantity	100 pieces
Extras	verschiedene Längen mit mehreren Gewinden in unterschiedlichen Größen auf Anfrage	Specials	Different lengths with multiple threads in different sizes available on request

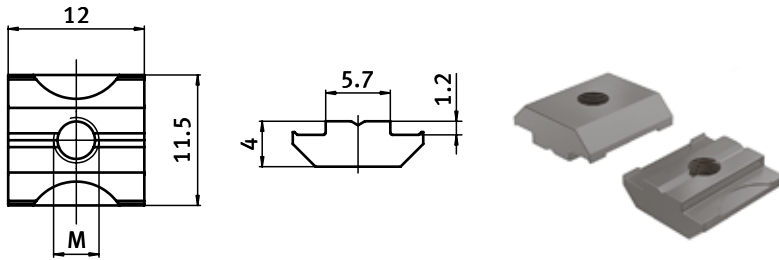

Nutenstein T-slot Nut	Größe Size	Gewicht [g] Weight [g]	Profil Profile	Teil-Nr. Part #
	M4	3.0	B	096484E
	M5	3.0	B	096485E

Nutmuttern und -schrauben *T-Nuts and T-Bolts*

Nutensteine *T-slot Nuts*

Nut 6,5 *Slot 6,5*



NUTENSTEIN 10,15 × 5,0 MM, EINSCHWENKBAR

ROLL-IN T-SLOT NUT 10.15 × 5.0 MM

Ausführung Nut 6,5 (0,256"), mit Federkugel, Stahl
Beschreibung einschwenkbarer Nutenstein mit Federkugel
Material Nutenstein: Stahl, verzinkt
 Kugel: Edelstahl
Liefereinheit 100 Stück

Extras ⚡ elektrostatisch entladend, verschiedene Längen mit mehreren Gewinden in unterschiedlichen Größen auf Anfrage

Model Slot 6.5 (0.256"), with spring loaded ball, steel

Description Roll-in T-slot nut with spring loaded ball

Material T-slot nut: Zinc plated steel
 Ball: Stainless steel

Pack Quantity 100 pieces

Specials ⚡ electrostatically discharging, different lengths with multiple threads in different sizes available on request

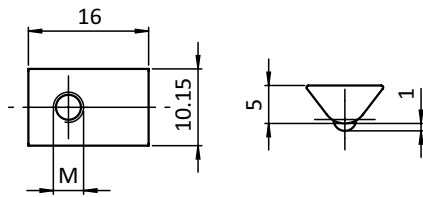

Nutenstein T-slot Nut	Größe Size	Gewicht [g] Weight [g]	Teil-Nr. Part #
	M4	4.0	096274
	M5	3.2	096275
	M6	2.4	096276

Nutmuttern und -schrauben *T-Nuts and T-Bolts*

Nutensteine *T-slot Nuts*

Nut 8 *Slot 8*



NUTENSTEIN 10,8 × 4,1 MM, EINSCHWENKBAR

ROLL-IN T-SLOT NUT 10.8 × 4.1 MM

<p>Ausführung Nut 8, mit Führungssteg, Stahl</p> <p>Beschreibung einschwenkbarer Nutenstein mit Führungssteg</p> <p>Material Stahl, verzinkt</p> <p>Liefereinheit 100 Stück</p> <p>Extras elektrostatisch entladend, verschiedene Längen mit mehreren Gewinden in unterschiedlichen Größen auf Anfrage</p>	<p>Model Slot 8, self-aligning, steel</p> <p>Description Self-aligning roll-in T-slot nut</p> <p>Material Zinc plated steel</p> <p>Pack Quantity 100 pieces</p> <p>Specials electrostatically discharging, different lengths with multiple threads in different sizes available on request</p>
--	--

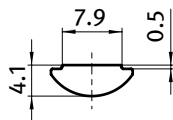
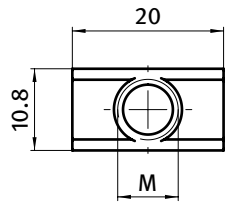

Nutenstein <i>T-slot Nut</i>	Größe <i>Size</i>	Gewicht [g] <i>Weight [g]</i>	Teil-Nr. <i>Part #</i>
	M4	5.0	096424
	M5	4.5	096425
	M6	4.3	096426
	M8	4.0	096428

Nutmuttern und -schrauben *T-Nuts and T-Bolts*

Nutensteine *T-slot Nuts*

Nut 8 *Slot 8*



NUTENSTEIN 10,8 × 4,1 MM, EINSCHWENKBAR

ROLL-IN T-SLOT NUT 10.8 × 4.1 MM

<p>Ausführung Nut 8, mit Führungssteg und Federblech, Stahl / Edelstahl</p> <p>Beschreibung einschwenkbarer Nutenstein mit Führungssteg und Federblech</p> <p>Material Stahl, verzinkt Edelstahl 1.4301 / 1.4305</p> <p>Liefereinheit 100 Stück</p> <p>Extras ⚡ elektrostatisch entladend, verschiedene Längen mit mehreren Gewinden in unterschiedlichen Größen auf Anfrage</p>	<p>Model Slot 8, self-aligning with spring leaf, steel / stainless steel</p> <p>Description Self-aligning roll-in T-slot nut with spring leaf</p> <p>Material Zinc plated steel Stainless Steel SS304 / SS303</p> <p>Pack Quantity 100 pieces</p> <p>Specials ⚡ electrostatically discharging, different lengths with multiple threads in different sizes available on request</p>
---	---

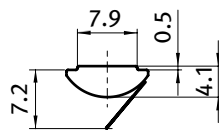
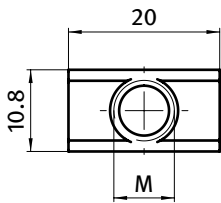

Nutenstein T-slot Nut	Größe Size	Gewicht [g] Weight [g]	Teil-Nr. Part #
Stahl <i>Steel</i>	M4	5.0	096424F
	M5	4.8	096425F
	M6	4.5	096426F
	M8	4.0	096428F
Edelstahl <i>stainless steel</i>	M4	5.0	096424FE
	M5	4.8	096425FE
	M6	4.5	096426FE
	M8	4.0	096428FE



Nutmuttern und -schrauben *T-Nuts and T-Bolts*

Nutensteine *T-slot Nuts*

Nut 8 *Slot 8*



NUTENSTEIN 11,0 × 4,1 MM, EINSCHWENKBAR

ROLL-IN T-SLOT NUT 11.0 × 4.1 MM

Ausführung Nut 8, mit Führungssteg und Federblech, Stahl
Beschreibung einschwenkbarer Nutenstein mit Führungssteg und Federblech
Material Stahl
Liefereinheit 100 Stück
Extras ⚡ elektrostatisch entladend, verschiedene Längen mit mehreren Gewinden in unterschiedlichen Größen auf Anfrage

Model *Slot 8, self-aligning with spring leaf, steel*
Description *Self-aligning roll-in T-slot nut with spring leaf*
Material *Steel*
Pack Quantity *100 pieces*
Specials ⚡ *electrostatically discharging, different lengths with multiple threads in different sizes available on request*

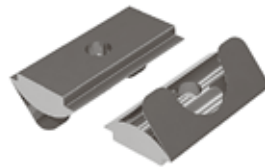
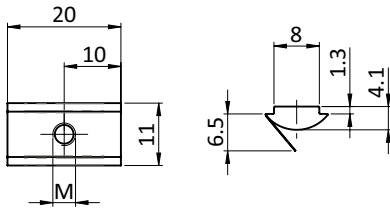

Nutenstein T-slot Nut	Größe Size	Gewicht [g] Weight [g]	Teil-Nr. Part #
	M4	4.0	096494F
	M5	3.9	096495F
	M6	3.8	096496F
	M8	3.7	096498F

Nutmuttern und -schrauben *T-Nuts and T-Bolts*

Nutensteine *T-slot Nuts*

Nut 8 *Slot 8*



NUTENSTEIN 11,6 × 4,6 MM, EINSCHWENKBAR

ROLL-IN T-SLOT NUT 11.6 × 4.6 MM

Ausführung	Nut 8, mit Führungssteg, Stahl	Model	Slot 8, self-aligning, steel
Beschreibung	einschwenkbarer Nutenstein mit Führungssteg	Description	Self-aligning roll-in T-slot nut
Material	Nutenstein: Stahl, verzinkt Profil: Stahl, blank, ohne Gewinde	Material	T-slot nut: Zinc plated steel Rod: Steel, plain, without thread
Liefereinheit	100 Stück	Pack Quantity	100 pieces
Extras	⚡ elektrostatisch entladend, verschiedene Längen mit mehreren Gewinden in unterschiedlichen Größen auf Anfrage	Specials	⚡ electrostatically discharging, different lengths with multiple threads in different sizes available on request
Hinweis	* passende Feder siehe Seite 291	Tip	* Compatible spring see page 291

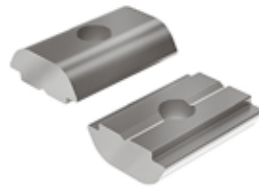
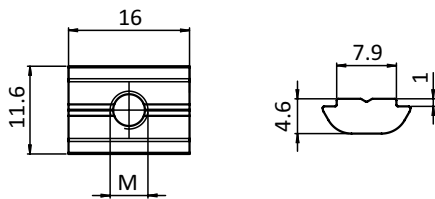

Nutenstein <i>T-slot Nut</i>	Größe <i>Size</i>	Gewicht [g] <i>Weight [g]</i>	Profil <i>Profile</i>	Teil-Nr. <i>Part #</i>
	M4	4.2	B	* 096314
	M5	3.8	B	* 096315
	M6	3.2	B	* 096316
	M8	2.6	B	* 096318
Profil <i>Rod</i>	1500 mm	175.0	B	096310.1500

Nutmuttern und -schrauben *T-Nuts and T-Bolts*

Nutensteine *T-slot Nuts*

Nut 8 *Slot 8*



NUTENSTEIN 11,6 × 4,6 MM, EINSCHWENKBAR

ROLL-IN T-SLOT NUT 11.6 × 4.6 MM

Ausführung Nut 8, mit Führungssteg und Federblech, Stahl
Beschreibung einschwenkbarer Nutenstein mit Führungssteg und Federblech, ⚡ elektrostatisch entladend
Material Stahl, verzinkt
Liefereinheit 100 Stück
Extras verschiedene Längen mit mehreren Gewinden in unterschiedlichen Größen auf Anfrage

Model *Slot 8, self-aligning with spring leaf, steel*
Description *Self-aligning roll-in T-slot nut with spring leaf, ⚡ electrostatically discharging*
Material *Zinc plated steel*
Pack Quantity *100 pieces*
Specials *Different lengths with multiple threads in different sizes available on request*

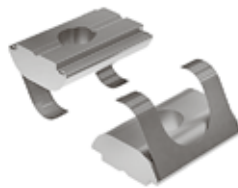
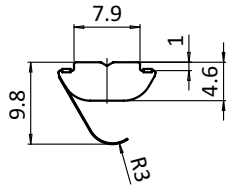
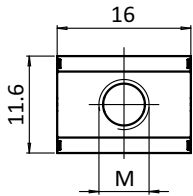

Nutenstein T-slot Nut	Größe Size	Gewicht [g] Weight [g]	Profil Profile	Teil-Nr. Part #
	M4	4.8	B	096314F
	M5	4.7	B	096315F
	M6	4.4	B	096316F
	M8	3.6	B	096318F

Nutmuttern und -schrauben *T-Nuts and T-Bolts*

Nutensteine *T-slot Nuts*

Nut 8 *Slot 8*



NUTENSTEIN 12,0 × 7,2 MM, EINSCHWENKBAR

ROLL-IN T-SLOT NUT 12.0 × 7.2 MM

Ausführung Nut 8, mit Führungssteg und Federkugel, Stahl
Beschreibung einschwenkbarer Nutenstein mit Führungssteg und Federkugel
Material Nutenstein: Stahl, verzinkt
 Kugel: Edelstahl
Liefereinheit 100 Stück
Extras elektrostatisch entladend, verschiedene Längen mit mehreren Gewinden in unterschiedlichen Größen auf Anfrage

Model *Slot 8, self-aligning with spring loaded ball, steel*
Description *Self-aligning roll-in T-slot nut with spring loaded ball*
Material *T-slot nut: Zinc plated steel
 Ball: Stainless steel*
Pack Quantity *100 pieces*
Specials *electrostatically discharging, different lengths with multiple threads in different sizes available on request*

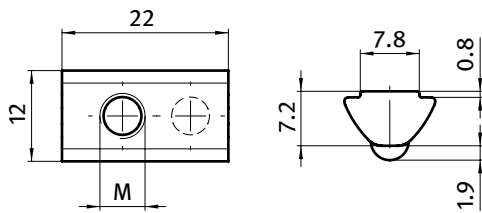

Nutenstein
T-slot Nut

Größe
Size

Gewicht [g]
Weight [g]

Teil-Nr.
Part #

M6

10.5

096466

M8

8.5

096468

Nutmuttern und -schrauben *T-Nuts and T-Bolts*

Nutensteine *T-slot Nuts*

Nut 8 *Slot 8*



NUTENSTEIN 12,5 × 6,0 MM, EINSCHWENKBAR

ROLL-IN T-SLOT NUT 12.5 × 6.0 MM

Ausführung	Nut 8, mit Führungssteg und Federkugel, Stahl	Model	Slot 8, self-aligning with spring loaded ball, steel
Beschreibung	einschwenkbarer Nutenstein mit Führungssteg und Federkugel	Description	Self-aligning roll-in T-slot nut with spring loaded ball
Material	Nutenstein: Stahl, verzinkt Profil: Stahl, blank, ohne Gewinde Kugel: Edelstahl	Material	T-slot nut: Zinc plated steel Rod: Steel, plain, without thread Ball: Stainless steel
Liefereinheit	100 Stück	Pack Quantity	100 pieces
Extras	⚡ elektrostatisch entladend, verschiedene Längen mit mehreren Gewinden in unterschiedlichen Größen auf Anfrage	Specials	⚡ electrostatically discharging, different lengths with multiple threads in different sizes available on request

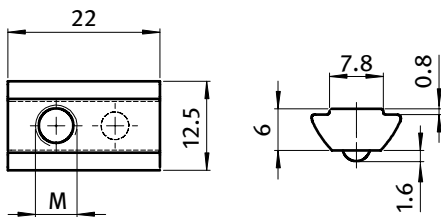

Nutenstein T-slot Nut	Größe Size	Gewicht [g] Weight [g]	Teil-Nr. Part #
	M4	9.6	096404
	M5	9.5	096405
	M6	9.0	096406
	M8	8.1	096408
Profil Rod	1500 mm	723.0	096400.1500

Nutmuttern und -schrauben *T-Nuts and T-Bolts*

Nutensteine *T-slot Nuts*

Nut 8 *Slot 8*



NUTENSTEIN 12,5 × 6,0 MM, EINSCHWENKBAR

ROLL-IN T-SLOT NUT 12.5 × 6.0 MM

Ausführung Nut 8, mit Führungssteg und Federblech, Stahl

Beschreibung einschwenkbarer Nutenstein mit Führungssteg und Federblech

Material Stahl, verzinkt

Liefereinheit 100 Stück

Extras ⚡ elektrostatisch entladend, verschiedene Längen mit mehreren Gewinden in unterschiedlichen Größen auf Anfrage

Model Slot 8, self-aligning with spring leaf, steel

Description Self-aligning roll-in T-slot nut with spring leaf

Material Zinc plated steel

Pack Quantity 100 pieces

Specials ⚡ electrostatically discharging, different lengths with multiple threads in different sizes available on request

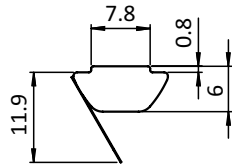
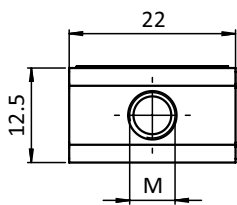

Nutenstein
T-slot Nut

Größe
Size

Gewicht [g]
Weight [g]

Teil-Nr.
Part #

M6

9.0

096406F

Nutmuttern und -schrauben *T-Nuts and T-Bolts*

Nutensteine *T-slot Nuts*

Nut 8 *Slot 8*



NUTENSTEIN 12,9 × 7,2 MM, EINSCHWENKBAR

ROLL-IN T-SLOT NUT 12.9 × 7.2 MM

Ausführung	Nut 8, mit Führungssteg und Federkugel, Stahl	Model	<i>Slot 8, self-aligning with spring loaded ball, steel</i>
Beschreibung	einschwenkbarer Nutenstein mit Führungssteg und Federkugel	Description	<i>Self-aligning roll-in T-slot nut with spring loaded ball</i>
Material	Nutenstein: Stahl, verzinkt Profil: Stahl, blank, ohne Gewinde Kugel: Edelstahl	Material	<i>T-slot nut: Zinc plated steel Rod: Steel, plain, without thread Ball: Stainless steel</i>
Liefereinheit	100 Stück	Pack Quantity	<i>100 pieces</i>
Extras	⚡ elektrostatisch entladend, verschiedene Längen mit mehreren Gewinden in unterschiedlichen Größen auf Anfrage	Specials	⚡ <i>electrostatically discharging, different lengths with multiple threads in different sizes available on request</i>

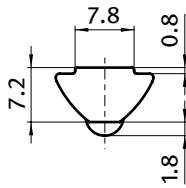
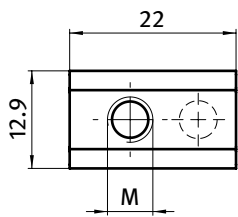

Nutenstein <i>T-slot Nut</i>	Größe <i>Size</i>	Gewicht [g] <i>Weight [g]</i>	Teil-Nr. <i>Part #</i>
	M4	10.5	096324
	M5	10.0	096325
	M6	10.0	096326
	M8	9.0	096328
Profil Rod	1500 mm	783.5	096320.1500

Nutmuttern und -schrauben *T-Nuts and T-Bolts*

Nutensteine *T-slot Nuts*

Nut 8 *Slot 8*



NUTENSTEIN 13,0 × 10,0 MM, EINSCHWENKBAR

ROLL-IN T-SLOT NUT 13.0 × 10.0 MM

Ausführung	Nut 8, mit Führungssteg und Federkugel, Aluminium / Edelstahl	Model	<i>Slot 8, self-aligning with spring loaded ball, Aluminum / stainless steel</i>
Beschreibung	einschwenkbarer Nutenstein mit Führungssteg und Federkugel	Description	<i>Self-aligning roll-in T-slot nut with spring loaded ball</i>
Material	Nutenstein: Aluminium Kugel: Edelstahl	Material	<i>T-slot nut: Aluminum Ball: Stainless steel</i>
Liefereinheit	100 Stück	Pack Quantity	<i>100 pieces</i>
Extras	⚡ elektrostatisch entladend, verschiedene Längen mit mehreren Gewinden in unterschiedlichen Größen auf Anfrage	Specials	<i>⚡ electrostatically discharging, different lengths with multiple threads in different sizes available on request</i>

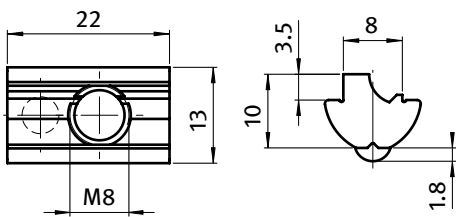

Nutenstein <i>T-slot Nut</i>	Größe <i>Size</i>	Gewicht [g] <i>Weight [g]</i>	Teil-Nr. <i>Part #</i>
Aluminum <i>Aluminium</i>	M5	4.5	096095
	M6	4.3	096096
	M8	3.9	096098



Nutmuttern und -schrauben *T-Nuts and T-Bolts*

Nutensteine *T-slot Nuts*

Nut 8 *Slot 8*



NUTENSTEIN 13,4 × 7,6 MM, EINSCHWENKBAR

ROLL-IN T-SLOT NUT 13.4 × 7.6 MM

Ausführung	Nut 8, mit Führungssteg und Federkugel, Stahl / Edelstahl	Model	Slot 8, self-aligning with spring loaded ball, steel / stainless steel
Beschreibung	einschwenkbarer Nutenstein mit Führungssteg und Federkugel	Description	Self-aligning roll-in T-slot nut with spring loaded ball
Material	Nutenstein: Stahl, verzinkt / Edelstahl 1.4301 / 1.4305 Profil: Stahl, blank, ohne Gewinde Kugel: Edelstahl	Material	T-slot nut: Zinc plated steel / stainless steel SS304 / SS303 Rod: Steel, plain, without thread Ball: Stainless steel
Liefereinheit	100 Stück	Pack Quantity	100 pieces
Extras	⚡ elektrostatisch entladend, verschiedene Längen mit mehreren Gewinden in unterschiedlichen Größen auf Anfrage	Specials	⚡ electrostatically discharging, different lengths with multiple threads in different sizes available on request

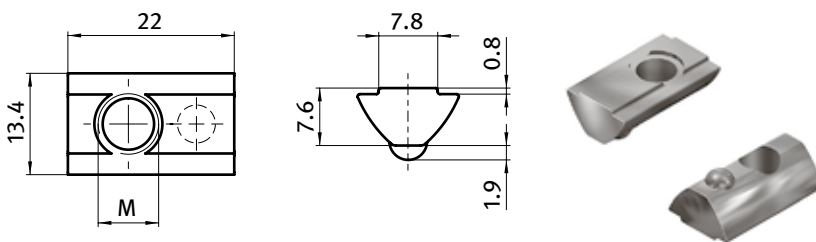

Nutenstein <i>T-slot Nut</i>	Größe <i>Size</i>	Gewicht [g] <i>Weight [g]</i>	Teil-Nr. <i>Part #</i>
Stahl <i>Steel</i>	M4	11.2	096334
	M5	11.0	096335
	M6	10.5	096336
	M8	9.5	096338
Edelstahl <i>Stainless steel</i>	M5	10.5	096335E
	M6	10.0	096336E
	M8	9.0	096338E
Profil <i>Rod</i>	1500 mm	831.0	096330.1500

Nutmuttern und -schrauben *T-Nuts and T-Bolts*

Nutensteine *T-slot Nuts*

Nut 8 *Slot 8*



NUTENSTEIN 13,5 × 7,2 MM, EINSCHWENKBAR

ROLL-IN T-SLOT NUT 13.5 × 7.2 MM

Ausführung	Nut 8, mit Führungssteg und Federkugel, Stahl / Edelstahl	Model	Slot 8, self-aligning with spring loaded ball, steel / stainless steel
Beschreibung	einschwenkbarer Nutenstein mit Führungssteg und Federkugel	Description	Self-aligning roll-in T-slot nut with spring loaded ball
Material	Nutenstein: Stahl, verzinkt / Edelstahl 1.4301 / 1.4305 Profil: Stahl, blank, ohne Gewinde Kugel: Edelstahl	Material	T-slot nut: Zinc plated steel / stainless steel SS304 / SS303 Rod: Steel, plain, without thread Ball: Stainless steel
Liefereinheit	100 Stück	Pack Quantity	100 pieces
Extras	☁ elektrostatisch entladend, verschiedene Längen mit mehreren Gewinden in unterschiedlichen Größen auf Anfrage	Specials	☁ electrostatically discharging, different lengths with multiple threads in different sizes available on request

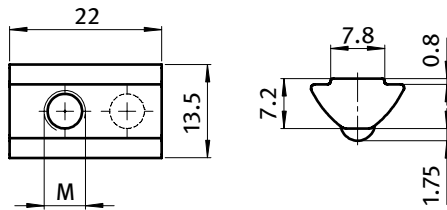

Nutenstein <i>T-slot Nut</i>	ESD	Größe <i>Size</i>	Gewicht [g] <i>Weight [g]</i>	Profil <i>Profile</i>	Teil-Nr. <i>Part #</i>
Stahl <i>Steel</i>		M3	10.9	I	096023
		M4	10.8	I	096024
		M5	10.5	I	096025
		M6	9.9	I	096026
		M8	9.0	I	096028
		10-32 UNF	10.9	I	09602U10-32
Stahl <i>Steel</i>	☁ elektrostatisch entladend <i>electrostatically discharging</i>	M4	10.8	I	096024S01
	☁ elektrostatisch entladend <i>electrostatically discharging</i>	M5	10.5	I	096025S01
	☁ elektrostatisch entladend <i>electrostatically discharging</i>	M6	9.9	I	096026S01
	☁ elektrostatisch entladend <i>electrostatically discharging</i>	M8	9.0	I	096028S01
Edelstahl <i>Stainless steel</i>		M5	10.5	I	096025E
		M6	9.9	I	096026E
		M8	9.0	I	096028E
Profil, Stahl <i>Rod, steel</i>		1500 mm	834.0	I	096020.1500

Nutmuttern und -schrauben *T-Nuts and T-Bolts*

Nutensteine *T-slot Nuts*

Nut 8 *Slot 8*



NUTENSTEIN 13,5 × 7,2 MM, EINSCHWENKBAR

ROLL-IN T-SLOT NUT 13.5 × 7.2 MM

Ausführung	Nut 8, mit Führungssteg und Federblech, Stahl	Model	<i>Slot 8, self-aligning with spring leaf, steel</i>
Beschreibung	einschwenkbarer Nutenstein mit Führungssteg und Federblech	Description	<i>Self-aligning roll-in T-slot nut with spring leaf</i>
Material	Stahl, verzinkt	Material	<i>Zinc plated steel</i>
Liefereinheit	100 Stück	Pack Quantity	<i>100 pieces</i>
Extras	⚡ elektrostatisch entladend, verschiedene Längen mit mehreren Gewinden in unterschiedlichen Größen auf Anfrage	Specials	⚡ <i>electrostatically discharging, different lengths with multiple threads in different sizes available on request</i>

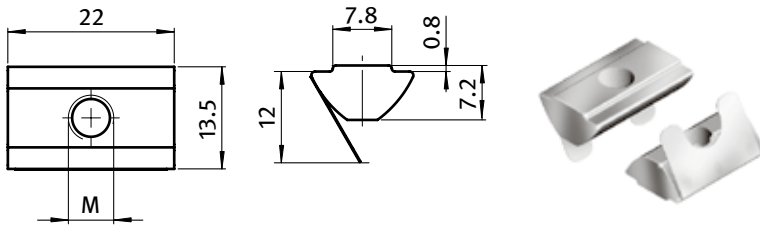

Nutenstein <i>T-slot Nut</i>	Größe <i>Size</i>	Gewicht [g] <i>Weight [g]</i>	Teil-Nr. <i>Part #</i>
	M4	11.4	096024F
	M5	11.1	096025F
	M6	10.8	096026F
	M8	9.9	096028F

Nutmuttern und -schrauben *T-Nuts and T-Bolts*

Nutensteine *T-slot Nuts*

Nut 8 *Slot 8*



NUTENSTEIN 13,7 × 7,0 MM, EINSCHWENKBAR

ROLL-IN T-SLOT NUT 13.7 × 7.0 MM

Ausführung	Nut 8, mit Federkugel, Stahl / Edelstahl	Model	Slot 8, with spring loaded ball, steel / stainless steel
Beschreibung	einschwenkbarer Nutenstein mit Federkugel	Description	Roll-in T-slot nut with spring loaded ball
Material	Nutenstein: Stahl, verzinkt / Edelstahl 1.4301 / 1.4305 Profil: Stahl / Edelstahl 1.4301 / 1.4305, blank, ohne Gewinde Kugel: Edelstahl	Material	T-slot nut: Zinc plated steel / stainless steel SS304 / SS303 Rod: Steel / stainless steel SS304 / SS303 plain, without thread Ball: Stainless steel
Liefereinheit	100 Stück	Pack Quantity	100 pieces
Extras	⚡ elektrostatisch entladend, verschiedene Längen mit mehreren Gewinden in unterschiedlichen Größen auf Anfrage	Specials	⚡ electrostatically discharging, different lengths with multiple threads in different sizes available on request

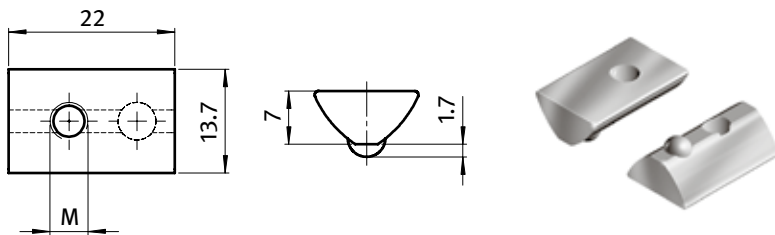

Nutenstein <i>T-slot Nut</i>	ESD	Größe <i>Size</i>	Gewicht [g] <i>Weight [g]</i>	Profil <i>Profile</i>	Teil-Nr. <i>Part #</i>
Stahl <i>Steel</i>		M3	10.9	I	096003
		M4	10.8	I	096004
		M5	10.5	I	096005
		M6	9.9	I	096006
		M8	9.0	I	096008
		10-32 UNF	10.9	I	09600U10-32
Stahl <i>Steel</i>	⚡ elektrostatisch entladend <i>electrostatically discharging</i>	M4	10.8	I	096004S01
	⚡ elektrostatisch entladend <i>electrostatically discharging</i>	M5	10.5	I	096005S01
	⚡ elektrostatisch entladend <i>electrostatically discharging</i>	M6	9.9	I	096006S01
	⚡ elektrostatisch entladend <i>electrostatically discharging</i>	M8	9.0	I	096008S01
Edelstahl <i>Stainless steel</i>		M3	10.9	I	096003E
		M4	10.8	I	096004E
		M5	10.5	I	096005E
		M6	9.9	I	096006E
		M8	9.0	I	096008E
Profil, Stahl <i>Rod, steel</i>		1500 mm	799.5	I	096000.1500
Profil, Edelstahl <i>Rod, stainless steel</i>		1500 mm	799.5	I	096000E.1500

Nutmuttern und -schrauben *T-Nuts and T-Bolts*

Nutensteine *T-slot Nuts*

Nut 8 *Slot 8*



NUTENSTEIN 16,0 × 6,0 MM

T-SLOT NUT 16.0 × 6.0 MM

Ausführung	Nut 8, mit Führungssteg, Stahl	Model	Slot 8, self-aligning, steel
Beschreibung	Nutenstein mit Führungssteg	Description	Self-aligning T-slot nut
Material	Nutenstein: Stahl, verzinkt Profil: Stahl, blank, ohne Gewinde	Material	T-slot nut: Zinc plated steel Rod: Steel, plain, without thread
Liefereinheit	100 Stück	Pack Quantity	100 pieces
Extras	⚡ elektrostatisch entladend, verschiedene Längen mit mehreren Gewinden in unterschiedlichen Größen auf Anfrage	Specials	⚡ electrostatically discharging, different lengths with multiple threads in different sizes available on request
Hinweis	* passende Feder siehe Seite 291	Tip	* Compatible spring see page 291

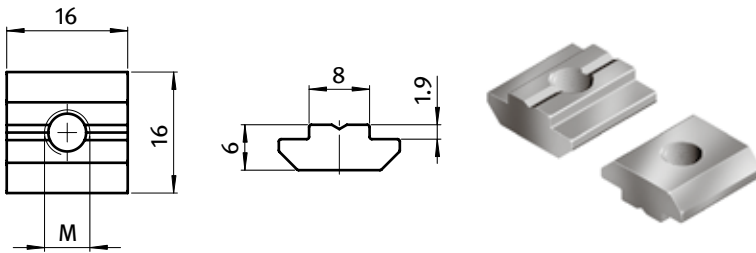

Nutenstein <i>T-slot Nut</i>	Größe <i>Size</i>	Gewicht [g] <i>Weight [g]</i>	Profil <i>Profile</i>	Teil-Nr. <i>Part #</i>
	M4	8.6	B	*096014
	M5	8.2	B	*096015
	M6	7.8	B	*096016
	M8	7.2	B	*096018
Profil <i>Rod</i>	1500 mm	873.0	B	096010.1500

Nutmuttern und -schrauben *T-Nuts and T-Bolts*

Nutensteine *T-slot Nuts*

Nut 8 *Slot 8*



NUTENSTEIN 17,0 × 8,0 MM

T-SLOT NUT 17.0 × 8.0 MM

Ausführung Nut 8, mit Führungssteg und Federkugel, Stahl

Beschreibung Nutenstein mit Führungssteg und Federkugel

Material Nutenstein: Stahl, verzinkt
 Profil: Stahl, blank, ohne Gewinde
 Kugel: Edelstahl

Liefereinheit 100 Stück

Extras elektrostatisch entladend, verschiedene Längen mit mehreren Gewinden in unterschiedlichen Größen auf Anfrage

Model Slot 8, self-aligning, with spring loaded ball, steel

Description Self-aligning T-slot nut with spring loaded ball

Material T-slot nut: Zinc plated steel
 Rod: Steel, plain, without thread
 Ball: Stainless steel

Pack Quantity 100 pieces

Specials electrostatically discharging, different lengths with multiple threads in different sizes available on request

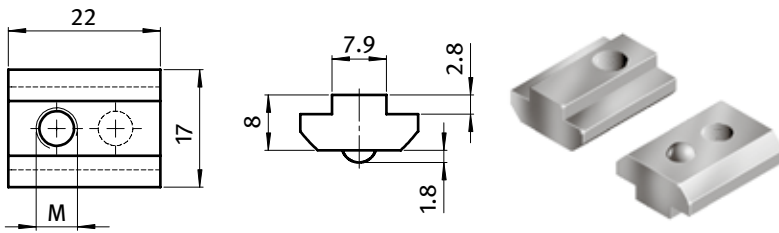

Nutenstein <i>T-slot Nut</i>	Größe <i>Size</i>	Gewicht [g] <i>Weight [g]</i>	Teil-Nr. <i>Part #</i>
	M5	16.0	096565
	M6	15.7	096566
	M8	15.4	096568
Profil <i>Rod</i>	1500 mm	1210.5	096560.1500

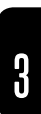

Nutmuttern und -schrauben *T-Nuts and T-Bolts*

Nutensteine *T-slot Nuts*

Nut 8 *Slot 8*



NUTENSTEIN 17,0 × 9,6 MM

T-SLOT NUT 17.0 × 9.6 MM

Ausführung	Nut 8, mit Federkugel, Stahl / Edelstahl	Model	Slot 8, with spring loaded ball, steel / stainless steel
Beschreibung	Nutenstein mit Führungssteg und Federkugel	Description	Self-aligning T-slot nut with spring loaded ball
Material	Nutenstein: Stahl, verzinkt / Edelstahl 1.4301 / 1.4305 Profil: Stahl, blank / Edelstahl 1.4301 / 1.4305 Kugel: Edelstahl	Material	T-slot nut: Zinc plated steel / stainless steel SS304 / SS303 Rod: Steel / stainless steel SS304 / SS303 Ball: Stainless steel
Liefereinheit	100 Stück	Pack Quantity	100 pieces
Extras	⚡ elektrostatisch entladend, verschiedene Längen mit mehreren Gewinden in unterschiedlichen Größen auf Anfrage	Specials	⚡ electrostatically discharging, different lengths with multiple threads in different sizes available on request

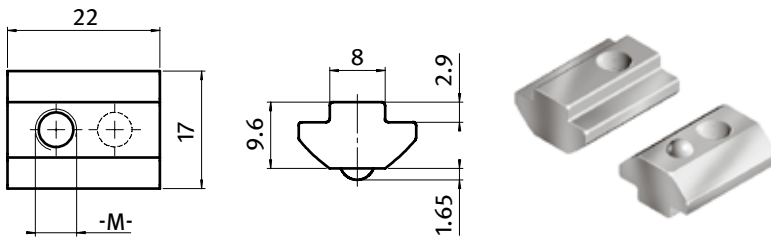

Nutenstein <i>T-slot Nut</i>	Größe <i>Size</i>	Gewicht [g] <i>Weight [g]</i>	Profil <i>Profile</i>	Teil-Nr. <i>Part #</i>
Stahl <i>Steel</i>	M4	19.0	I	096064
	M5	18.5	I	096065
	M6	18.0	I	096066
	M8	17.0	I	096068
Edelstahl <i>Stainless steel</i>	M6	18.0	I	096066E
	M8	17.0	I	096068E
Profil, Stahl <i>Rod, steel</i>	1500 mm	1344.0	I	096060.1500

Nutmuttern und -schrauben *T-Nuts and T-Bolts*

Nutensteine *T-slot Nuts*

Nut 8 *Slot 8*



NUTENSTEIN 18,0 × 6,8 MM

T-SLOT NUT 18.0 × 6.8 MM

Ausführung Nut 8, mit Federkugel, Stahl
Beschreibung Nutenstein mit Federkugel
Material Nutenstein: Stahl, verzinkt
 Profil: Stahl, blank, ohne Gewinde
 Kugel: Edelstahl
Liefereinheit 100 Stück
Extras elektrostatisch entladend, verschiedene Längen mit mehreren Gewinden in unterschiedlichen Größen auf Anfrage

Model *Slot 8, with spring loaded ball, steel*
Description *T-slot nut with spring loaded ball*
Material *T-slot nut: Zinc plated steel
 Rod: Steel, plain, without thread
 Ball: Stainless steel*
Pack Quantity *100 pieces*
Specials *electrostatically discharging, different lengths with multiple threads in different sizes available on request*

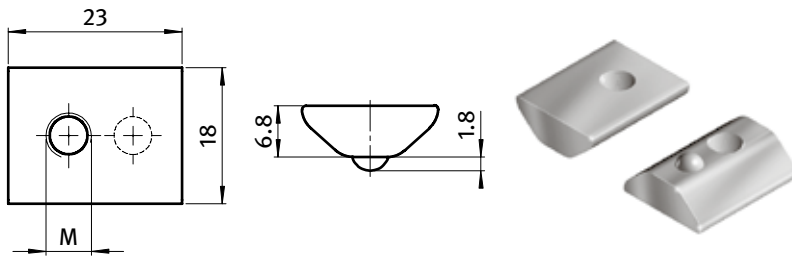

Nutenstein <i>T-slot Nut</i>	Größe <i>Size</i>	Gewicht [g] <i>Weight [g]</i>	Profil <i>Profile</i>	Teil-Nr. <i>Part #</i>
	M5	16.4	I	096115
	M6	16.0	I	096116
	M8	15.0	I	096118
Profil <i>Rod</i>	1500 mm	1114.5	I	096110.1500



Nutmuttern und -schrauben *T-Nuts and T-Bolts*

Nutensteine *T-slot Nuts*

Nut 8 *Slot 8*



NUTENSTEIN 18,0 × 12,2 MM

T-SLOT NUT 18.0 × 12.2 MM

Ausführung	Nut 8, mit Führungssteg und Federkugel, Stahl	Model	Slot 8, self-aligning, with spring loaded ball, steel
Beschreibung	Nutenstein mit Führungssteg und Federkugel	Description	Self-aligning T-slot nut with spring loaded ball
Material	Nutenstein: Stahl, verzinkt Profil: Stahl, blank, ohne Gewinde Kugel: Edelstahl	Material	T-slot nut: Zinc plated steel Rod: Steel, plain, without thread Ball: Stainless steel
Liefereinheit	100 Stück	Pack Quantity	100 pieces
Extras	⚡ elektrostatisch entladend, verschiedene Längen mit mehreren Gewinden in unterschiedlichen Größen auf Anfrage	Specials	⚡ electrostatically discharging, different lengths with multiple threads in different sizes available on request

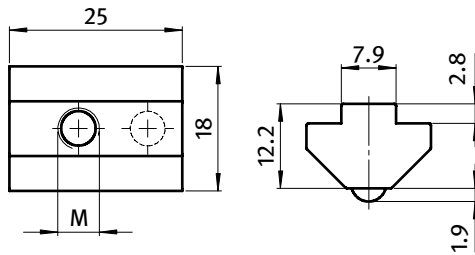

Nutenstein <i>T-slot Nut</i>	Größe <i>Size</i>	Gewicht [g] <i>Weight [g]</i>	Teil-Nr. <i>Part #</i>
	M5	27.0	096455
	M6	26.7	096456
	M8	26.3	096458
Profil <i>Rod</i>	1500 mm	1905.0	096450.1500

Nutmuttern und -schrauben *T-Nuts and T-Bolts*

Nutensteine *T-slot Nuts*

Nut 10 *Slot 10*



NUTENSTEIN 14,0 × 5,2 MM, EINSCHWENKBAR

ROLL-IN T-SLOT NUT 14.0 × 5.2 MM

Ausführung	Nut 10, mit Führungssteg, Stahl	Model	Slot 10, self-aligning, steel
Beschreibung	einschwenkbarer Nutenstein mit Führungssteg	Description	Self-aligning roll-in T-slot nut
Material	Nutenstein: Stahl, verzinkt Profil: Stahl, blank, ohne Gewinde	Material	T-slot nut: Zinc plated steel Rod: Steel, plain, without thread
Liefereinheit	100 Stück	Pack Quantity	100 pieces
Extras	⚡ elektrostatisch entladend, verschiedene Längen mit mehreren Gewinden in unterschiedlichen Größen auf Anfrage	Specials	⚡ electrostatically discharging, different lengths with multiple threads in different sizes available on request

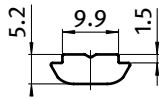
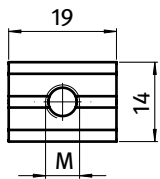

Nutenstein <i>T-slot Nut</i>	Größe <i>Size</i>	Gewicht [g] <i>Weight [g]</i>	Profil <i>Profile</i>	Teil-Nr <i>Part#</i>
	M4	8.0	B	096164
	M5	8.2	B	096165
	M6	7.6	B	096166
	M8	6.8	B	096168
	10-32 UNF	8.0	B	09616U10-32
Profil <i>Rod</i>	1500 mm	382.0	B	096160.1500

Nutmuttern und -schrauben *T-Nuts and T-Bolts*

Nutensteine *T-slot Nuts*

Nut 10 *Slot 10*



NUTENSTEIN 14,0 × 5,2 MM, EINSCHWENKBAR

ROLL-IN T-SLOT NUT 14.0 × 5.2 MM

Ausführung	Nut 10, mit Führungssteg und Federblech, Stahl	Model	Slot 10, self-aligning with spring leaf, steel
Beschreibung	einschwenkbarer Nutenstein mit Führungssteg und Federblech, ⚡ elektrostatisch entladend	Description	Self-aligning roll-in T-slot nut with spring leaf, ⚡ electrostatically discharging
Material	Stahl	Material	Steel
Liefereinheit	100 Stück	Pack Quantity	100 pieces
Extras	verschiedene Längen mit mehreren Gewinden in unterschiedlichen Größen auf Anfrage	Specials	Different lengths with multiple threads in different sizes available on request

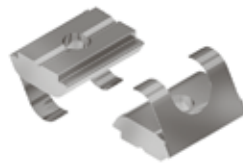
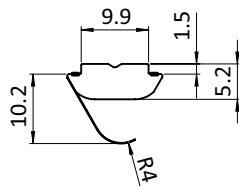
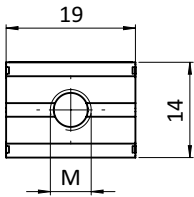

Nutenstein <i>T-slot Nut</i>	Größe <i>Size</i>	Gewicht [g] <i>Weight [g]</i>	Profil <i>Profile</i>	Teil-Nr <i>Part#</i>
	M4	7.7	B	096164F
	M5	7.6	B	096165F
	M6	7.4	B	096166F
	M8	7.1	B	096168F
	10-32 UNF	7.6	B	09616U10-32F

Nutmuttern und -schrauben *T-Nuts and T-Bolts*

Nutensteine *T-slot Nuts*

Nut 10 Slot 10



NUTENSTEIN 14,5 × 6,2 MM, EINSCHWENKBAR

ROLL-IN T-SLOT NUT 14.5 × 6.2 MM

Ausführung	Nut 10, mit Führungssteg und Federkugel, Stahl / Edelstahl	Model	Slot 10, self-aligning with spring loaded ball, steel / stainless steel
Beschreibung	einschwenkbarer Nutenstein mit Führungssteg und Federkugel	Description	Self-aligning roll-in T-slot nut with spring loaded ball
Material	Nutenstein: Stahl, verzinkt / Edelstahl 1.4301 / 1.4305 Profil: Stahl / Edelstahl 1.4301 / 1.4305, blank, ohne Gewinde Kugel: Edelstahl	Material	T-slot nut: Zinc plated steel / stainless steel SS304 / SS303 Rod: Steel / stainless steel SS304 / SS303 plain, without thread Ball: Stainless steel
Liefereinheit	100 Stück	Pack Quantity	100 pieces
Extras	⚡ elektrostatisch entladend, verschiedene Längen mit mehreren Gewinden in unterschiedlichen Größen auf Anfrage	Specials	⚡ electrostatically discharging, different lengths with multiple threads in different sizes available on request

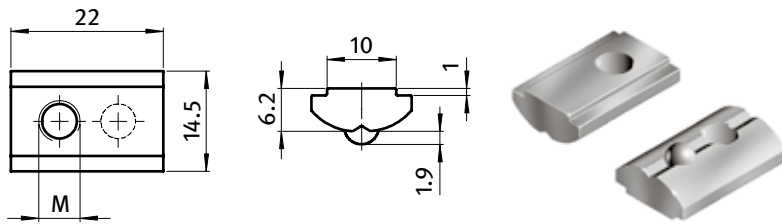

Nutenstein <i>T-slot Nut</i>	Größe <i>Size</i>	Gewicht [g] <i>Weight [g]</i>	Teil-Nr <i>Part#</i>
Stahl <i>Steel</i>	M4	11.8	096124
	M5	11.4	096125
	M6	11.1	096126
	M8	10.1	096128
Edelstahl <i>Stainless steel</i>	M4	11.8	096124E
	M5	11.4	096125E
	M6	11.1	096126E
	M8	10.1	096128E
Profil, Stahl <i>Rod, steel</i>	1500 mm	870.0	096120.1500
Profil, Edelstahl <i>Rod, stainless steel</i>	1500 mm	870.0	096120E.1500



Nutmuttern und -schrauben T-Nuts and T-Bolts

Nutensteine T-slot Nuts

Nut 10 Slot 10



NUTENSTEIN 14,5 × 10,9 MM, EINSCHWENKBAR

ROLL-IN T-SLOT NUT 14.5 × 10.9 MM

Ausführung	Nut 10, mit Führungssteg und Federblech	Model	Slot 10, self-aligning with spring leaf
Beschreibung	einschwenkbarer Nutenstein mit Führungssteg und Federblech	Description	Self-aligning roll-in T-slot nut with spring leaf
Material	Stahl, verzinkt / Edelstahl	Material	Zinc plated steel / stainless steel
Liefereinheit	100 Stück	Pack Quantity	100 pieces
Extras	⚡ elektrostatisch entladend, verschiedene Längen mit mehreren Gewinden in unterschiedlichen Größen auf Anfrage	Specials	⚡ electrostatically discharging, different lengths with multiple threads in different sizes available on request

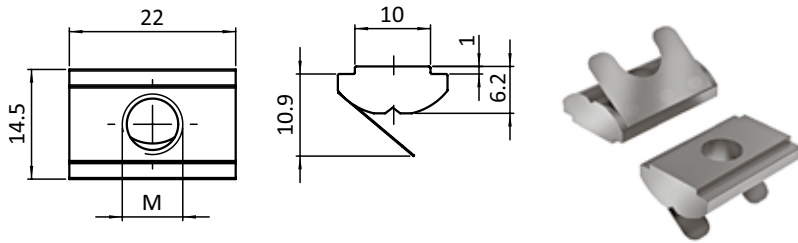

Nutenstein T-slot Nut		Größe Size	Gewicht [g] Weight [g]	Teil-Nr. Part #
Stahl <i>Steel</i>		M5	11.2	096125F
		M6	10.0	096126F
		M8	9.8	096128F
Edelstahl <i>Stainless steel</i>		M5	11.8	096125FE
		M6	11.4	096126FE
		M8	11.2	096128FE

Nutmuttern und -schrauben *T-Nuts and T-Bolts*

Nutensteine *T-slot Nuts*

Nut 10 *Slot 10*



NUTENSTEIN 15,0 × 6,0 MM, EINSCHWENKBAR

ROLL-IN T-SLOT NUT 15.0 × 6.0 MM

Ausführung	Nut 10, mit Führungssteg, Stahl	Model	Slot 10, self-aligning, steel
Beschreibung	einschwenkbarer Nutenstein mit Führungssteg	Description	Self-aligning roll-in T-slot nut
Material	Nutenstein: Stahl, verzinkt Profil: Stahl, blank, ohne Gewinde	Material	T-slot nut: Zinc plated steel Rod: Steel, plain, without thread
Liefereinheit	100 Stück	Pack Quantity	100 pieces
Extras	⚡ elektrostatisch entladend, verschiedene Längen mit mehreren Gewinden in unterschiedlichen Größen auf Anfrage	Specials	⚡ electrostatically discharging, different lengths with multiple threads in different sizes available on request
Hinweis	* passende Feder siehe Seite 291	Tip	* Compatible spring see page 291

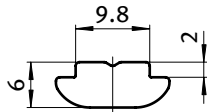
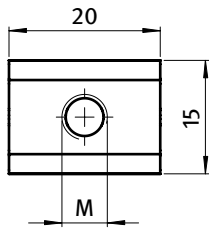

Nutenstein <i>T-slot Nut</i>	Größe <i>Size</i>	Gewicht [g] <i>Weight [g]</i>	Profil <i>Profile</i>	Teil-Nr. <i>Part #</i>
	M3	13.0	B	*096083
	M4	12.5	B	*096084
	M5	13.0	B	*096085
	M6	12.0	B	*096086
	M8	11.0	B	*096088
Profil <i>Rod</i>	1500 mm	841.5	B	096080.1500

Nutmuttern und -schrauben *T-Nuts and T-Bolts*

Nutensteine *T-slot Nuts*

Nut 10 *Slot 10*



NUTENSTEIN 15,0 × 6,0 MM, EINSCHWENKBAR

ROLL-IN T-SLOT NUT 15.0 × 6.0 MM

Ausführung	Nut 10, mit Führungssteg und Federblech, Stahl	Model	Slot 10, self-aligning with spring leaf, steel
Beschreibung	einschwenkbarer Nutenstein mit Führungssteg und Federblech	Description	Self-aligning roll-in T-slot nut with spring leaf
Material	Stahl, verzinkt	Material	Zinc plated steel
Liefereinheit	100 Stück	Pack Quantity	100 pieces
Extras	⚡ elektrostatisch entladend, verschiedene Längen mit mehreren Gewinden in unterschiedlichen Größen auf Anfrage	Specials	⚡ electrostatically discharging, different lengths with multiple threads in different sizes available on request

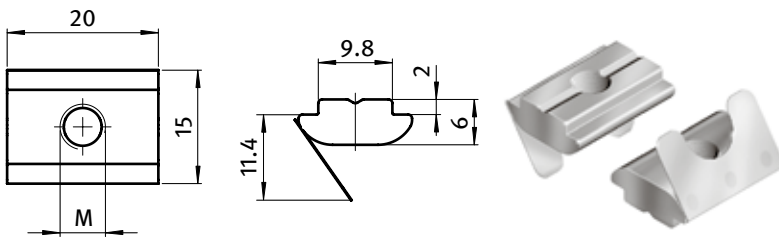

Nutenstein <i>T-slot Nut</i>	Größe <i>Size</i>	Gewicht [g] <i>Weight [g]</i>	Profil <i>Profile</i>	Teil-Nr. <i>Part #</i>
	M4	10.6	B	096084F
	M5	13.0	B	096085F
	M6	12.0	B	096086F
	M8	11.0	B	096088F

Nutmuttern und -schrauben *T-Nuts and T-Bolts*

Nutensteine *T-slot Nuts*

Nut 10 Slot 10



NUTENSTEIN 13,0 × 5,0 MM

T-SLOT NUT 13.0 × 5.0 MM

Ausführung Nut 10, mit Führungssteg, Stahl

Beschreibung Nutenstein mit Führungssteg

Material Stahl, verzinkt

Liefereinheit 100 Stück

Extras elektrostatisch entladend, verschiedene Längen mit mehreren Gewinden in unterschiedlichen Größen auf Anfrage

Model Slot 10, self-aligning, steel

Description Self-aligning T-slot nut

Material Zinc plated steel

Pack Quantity 100 pieces

Specials electrostatically discharging, different lengths with multiple threads in different sizes available on request

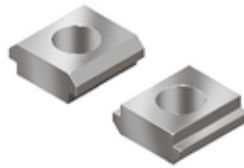
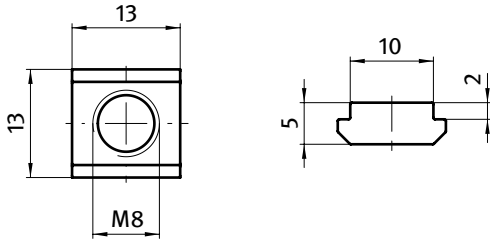

Nutenstein
T-slot Nut

Größe
Size

Gewicht [g]
Weight [g]

Teil-Nr.
Part #

M8

4.5

096348

Nutmuttern und -schrauben *T-Nuts and T-Bolts*

Nutensteine *T-slot Nuts*

Nut 10 *Slot 10*



NUTENSTEIN 15,0 × 8,0 MM

T-SLOT NUT 15.0 × 8.0 MM

Ausführung	Nut 10, mit Führungssteg, Stahl	Model	Slot 10, self-aligning, steel
Beschreibung	Nutenstein mit Führungssteg	Description	Self-aligning T-slot nut
Material	Stahl, verzinkt	Material	Zinc plated steel
Liefereinheit	100 Stück	Pack Quantity	100 pieces
Extras	⚡ elektrostatisch entladend, verschiedene Längen mit mehreren Gewinden in unterschiedlichen Größen auf Anfrage	Specials	⚡ electrostatically discharging, different lengths with multiple threads in different sizes available on request

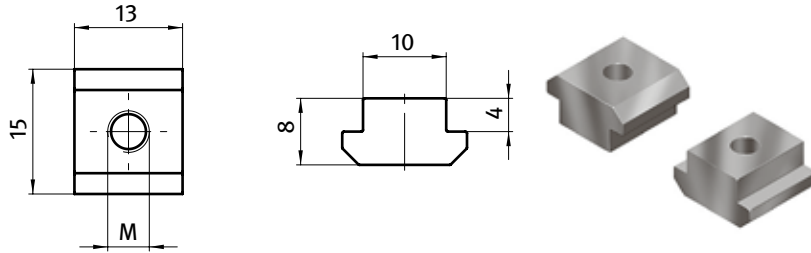

Nutenstein <i>T-slot Nut</i>	Größe <i>Size</i>	Gewicht [g] <i>Weight [g]</i>	Teil-Nr. <i>Part #</i>
	M5	9.0	096355
	M6	8.5	096356
	M8	7.5	096358

Nutmuttern und -schrauben *T-Nuts and T-Bolts*

Nutensteine *T-slot Nuts*

Nut 10 Slot 10



NUTENSTEIN 18,0 × 5,5 MM

T-SLOT NUT 18.0 × 5.5 MM

Ausführung Nut 10, mit Führungssteg, Stahl

Beschreibung Nutenstein mit Führungssteg

Material Stahl, verzinkt

Liefereinheit 100 Stück

Extras elektrostatisch entladend, verschiedene Längen mit mehreren Gewinden in unterschiedlichen Größen auf Anfrage

Model Slot 10, self-aligning, steel

Description Self-aligning T-slot nut

Material Zinc plated steel

Pack Quantity 100 pieces

Specials electrostatically discharging, different lengths with multiple threads in different sizes available on request

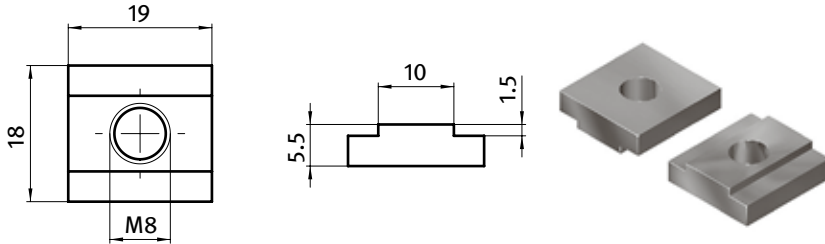

Nutenstein
T-slot Nut

Größe
Size

Gewicht [g]
Weight [g]

Teil-Nr.
Part #

M8

11.5

096928

Nutmuttern und -schrauben *T-Nuts and T-Bolts*

Nutensteine *T-slot Nuts*

Nut 10 *Slot 10*



NUTENSTEIN 18,0 × 7,5 MM

T-SLOT NUT 18.0 × 7.5 MM

Ausführung	Nut 10, mit Führungssteg, Stahl	Model	Slot 10, self-aligning, steel
Beschreibung	Nutenstein mit Führungssteg	Description	Self-aligning T-slot nut
Material	Nutenstein: Stahl, verzinkt Profil: Stahl, blank, ohne Gewinde	Material	T-slot nut: Zinc plated steel Rod: Steel, plain, without thread
Liefereinheit	100 Stück	Pack Quantity	100 pieces
Extras	⚡ elektrostatisch entladend, verschiedene Längen mit mehreren Gewinden in unterschiedlichen Größen auf Anfrage	Specials	⚡ electrostatically discharging, different lengths with multiple threads in different sizes available on request

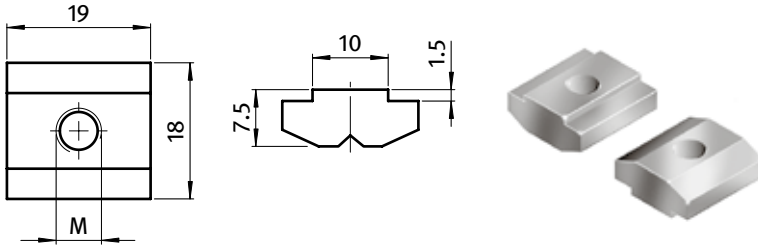

Nutenstein <i>T-slot Nut</i>	Größe <i>Size</i>	Gewicht [g] <i>Weight [g]</i>	Teil-Nr. <i>Part #</i>
	M4	16.5	096134
	M5	15.9	096135
	M6	15.4	096136
	M8	14.3	096138
Profil <i>Rod</i>	1500 mm	1299.0	096130.1500

Nutmuttern und -schrauben *T-Nuts and T-Bolts*

Nutensteine *T-slot Nuts*

Nut 10 *Slot 10*



NUTENSTEIN 18,0 × 8,0 MM

T-SLOT NUT 18.0 × 8.0 MM

Ausführung	Nut 10, mit Führungssteg, Stahl	Model	Slot 10, self-aligning, steel
Beschreibung	Nutenstein mit Führungssteg	Description	Self-aligning T-slot nut
Material	Stahl	Material	Steel
Liefereinheit	100 Stück	Pack Quantity	100 pieces
Extras	verschiedene Längen mit mehreren Gewinden in unterschiedlichen Größen auf Anfrage	Specials	Different lengths with multiple threads in different sizes available on request

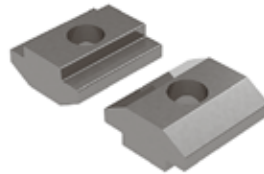
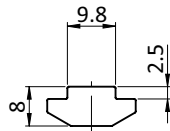
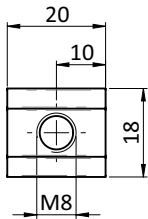

Nutenstein <i>T-slot Nut</i>	Größe <i>Size</i>	Gewicht [g] <i>Weight [g]</i>	Teil-Nr. <i>Part #</i>
	M8	8.0	096448

Nutmuttern und -schrauben *T-Nuts and T-Bolts*

Nutensteine *T-slot Nuts*

Nut 10 *Slot 10*



NUTENSTEIN 19,5 × 10,6 MM

T-SLOT NUT 19.5 × 10.6 MM

<p>Ausführung Nut 10, mit Führungssteg, Stahl</p> <p>Beschreibung Nutenstein mit Führungssteg</p> <p>Material Stahl, verzinkt</p> <p>Liefereinheit 100 Stück</p> <p>Extras ⚡ elektrostatisch entladend, verschiedene Längen mit mehreren Gewinden in unterschiedlichen Größen auf Anfrage</p>	<p>Model Slot 10, self-aligning, steel</p> <p>Description Self-aligning T-slot Nut</p> <p>Material Zinc plated steel</p> <p>Pack Quantity 100 pieces</p> <p>Specials ⚡ electrostatically discharging, different lengths with multiple threads in different sizes available on request</p>
--	--

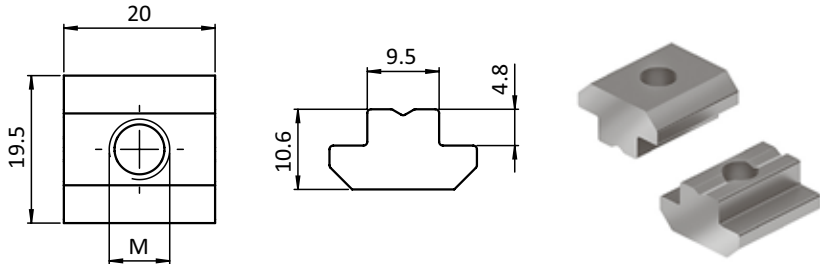

Nutenstein <i>T-slot Nut</i>	Größe <i>Size</i>	Gewicht [g] <i>Weight [g]</i>	Teil-Nr. <i>Part #</i>
	M8	18.6	096538
	M10	16.6	0965310



NUTENSTEIN 19,5 × 10,6 MM

T-SLOT NUT 19.5 × 10.6 MM

Ausführung	Nut 10, mit Führungssteg, Stahl	Model	Slot 10, self-aligning, steel
Beschreibung	Nutenstein mit Führungssteg	Description	Self-aligning T-slot nut
Material	Nutenstein: Stahl, verzinkt Profil: Stahl, blank, ohne Gewinde	Material	T-slot nut: Zinc plated steel Rod: Steel, plain, without thread
Liefereinheit	100 Stück	Pack Quantity	100 pieces
Extras	⚡ elektrostatisch entladend, verschiedene Längen mit mehreren Gewinden in unterschiedlichen Größen auf Anfrage	Specials	⚡ electrostatically discharging, different lengths with multiple threads in different sizes available on request
Hinweis	* passende Feder siehe Seite 291	Tip	* Compatible spring see page 291

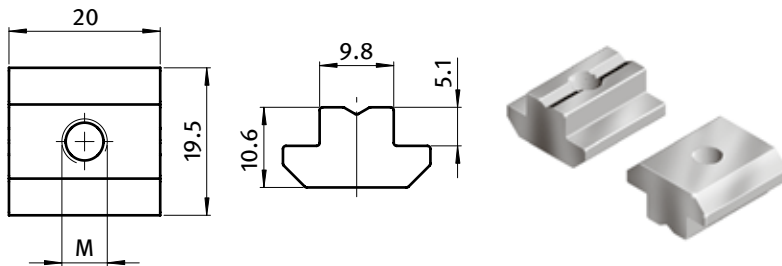

Nutenstein T-slot Nut	Größe Size	Gewicht [g] Weight [g]	Profil Profile	Teil-Nr. Part #
	M4	21.5	B	*096034
	M5	20.9	B	*096035
	M6	20.3	B	*096036
	M8	18.6	B	*096038
Profil Rod	1500 mm	1732.5	B	096030.1500

Nutmuttern und -schrauben *T-Nuts and T-Bolts*

Nutensteine *T-slot Nuts*

Nut 10 *Slot 10*



NUTENSTEIN 19,5 × 10,6 MM

T-SLOT NUT 19.5 × 10.6 MM

Ausführung	Nut 10, mit Führungssteg, Stahl / Edelstahl	Model	Slot 10, self-aligning, steel / stainless steel
Beschreibung	Nutenstein mit Führungssteg	Description	Self-aligning T-slot nut
Material	Stahl, verzinkt / Edelstahl 1.4301 / 1.4305	Material	Zinc plated steel / stainless steel SS304 / SS303
Liefereinheit	100 Stück	Pack Quantity	100 pieces
Extras	verschiedene Längen mit mehreren Gewinden in unterschiedlichen Größen auf Anfrage	Specials	Different lengths with multiple threads in different sizes available on request

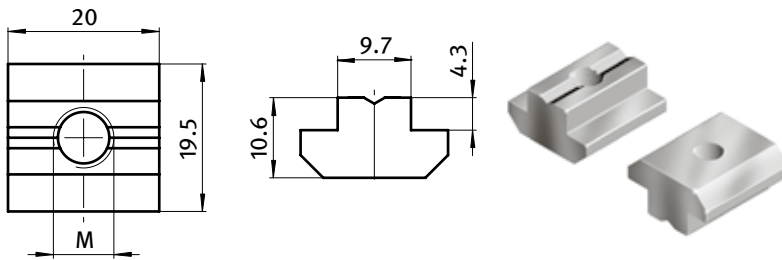

Nutenstein <i>T-slot Nut</i>	Größe <i>Size</i>	Gewicht [g] <i>Weight [g]</i>	Teil-Nr. <i>Part #</i>
Stahl <i>Steel</i>	M5	22.0	096395
	M6	20.4	096396
	M8	20.0	096398
Edelstahl <i>Stainless steel</i>	M6	22.6	096396E
	M8	21.0	096398E

Nutmuttern und -schrauben *T-Nuts and T-Bolts*

Nutensteine *T-slot Nuts*

Nut 10 *Slot 10*



NUTENSTEIN 19,5 × 10,6 MM

T-SLOT NUT 19.5 × 10.6 MM

Ausführung Nut 10, mit Führungssteg und Federkugel, Stahl
Beschreibung Nutenstein mit Führungssteg und Federkugel
Material Nutenstein: Stahl, verzinkt
 Kugel: Edelstahl
Liefereinheit 100 Stück
Extras verschiedene Längen mit mehreren Gewinden in unterschiedlichen Größen auf Anfrage

Model Slot 10, self-aligning with spring loaded ball, steel
Description Self-aligning T-slot nut with spring loaded ball
Material T-slot nut: Zinc plated steel
 Ball: Stainless steel
Pack Quantity 100 pieces
Specials Different lengths with multiple threads in different sizes available on request

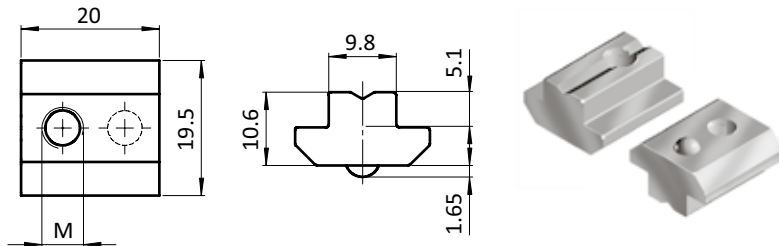

Nutenstein T-slot Nut	Größe Size	Gewicht [g] Weight [g]	Profil Profile	Teil-Nr. Part #
	M4	21.5	B	096030S06
	M5	20.9	B	096030S07
	M6	20.0	B	096030S08
	M8	18.6	B	096030S09

Nutmuttern und -schrauben *T-Nuts and T-Bolts*

Nutensteine *T-slot Nuts*

Nut 10 Slot 10



NUTENSTEIN 20,0 × 6,4 MM

T-SLOT NUT 20.0 × 6.4 MM

Ausführung	Nut 10, mit Führungssteg, Stahl	Model	Slot 10, self-aligning, steel
Beschreibung	Nutenstein mit Führungssteg	Description	Self-aligning T-slot nut
Material	Stahl, verzinkt	Material	Zinc plated steel
Liefereinheit	100 Stück	Pack Quantity	100 pieces
Extras	⚡ elektrostatisch entladend, verschiedene Längen mit mehreren Gewinden in unterschiedlichen Größen auf Anfrage	Specials	⚡ electrostatically discharging, different lengths with multiple threads in different sizes available on request

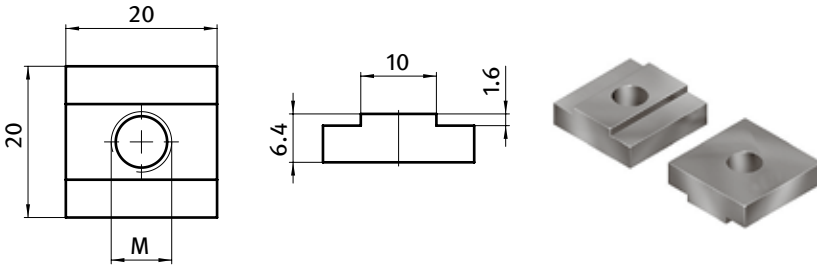

Nutenstein <i>T-slot Nut</i>	Größe <i>Size</i>	Gewicht [g] <i>Weight [g]</i>	Teil-Nr. <i>Part #</i>
	M5	17.0	096930S06
	M6	16.5	096930S07
	M8	15.5	096930S08



NUTENSTEIN 20,0 × 6,4 MM

T-SLOT NUT 20.0 × 6.4 MM

Ausführung Nut 10, mit Führungssteg und Federkugel, Stahl
Beschreibung Nutenstein mit Führungssteg und Federkugel
Material Nutenstein: Stahl, verzinkt
 Kugel: Edelstahl
Liefereinheit 100 Stück
Extras verschiedene Längen mit mehreren Gewinden in unterschiedlichen Größen auf Anfrage

Model Slot 10, self-aligning with spring loaded ball, steel
Description Self-aligning T-slot nut with spring loaded ball
Material T-slot nut: Zinc plated steel
 Ball: Stainless steel
Pack Quantity 100 pieces
Specials Different lengths with multiple threads in different sizes available on request

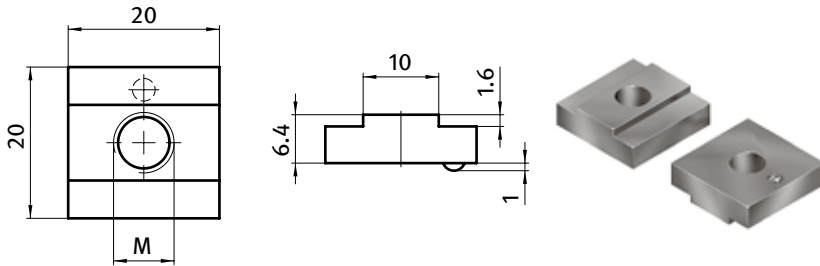

Nutenstein <i>T-slot Nut</i>	Größe <i>Size</i>	Gewicht [g] <i>Weight [g]</i>	Teil-Nr. <i>Part #</i>
	M4	17.0	096930S02
	M5	17.0	096930S03
	M6	16.5	096930S04
	M8	15.5	096930S05

Nutmuttern und -schrauben *T-Nuts and T-Bolts*

Nutensteine *T-slot Nuts*

Nut 11 Slot 11



NUTENSTEIN 13,1 × 5,3 MM, EINSCHWENKBAR

ROLL-IN-T-SLOT NUT 13.1 × 5.3 MM

<p>Ausführung Nut 11, mit Führungssteg und Federblech, Stahl</p> <p>Beschreibung einschwenkbarer Nutenstein mit Führungssteg und Federblech</p> <p>Material Stahl, verzinkt</p> <p>Liefereinheit 100 Stück</p> <p>Extras elektrostatisch entladend, verschiedene Längen mit mehreren Gewinden in unterschiedlichen Größen auf Anfrage</p>	<p>Model Slot 11, self-aligning with spring leaf, steel</p> <p>Description Self-aligning roll-in T-slot nut with spring leaf</p> <p>Material Zinc plated steel</p> <p>Pack Quantity 100 pieces</p> <p>Specials electrostatically discharging, different lengths with multiple threads in different sizes available on request</p>
---	---

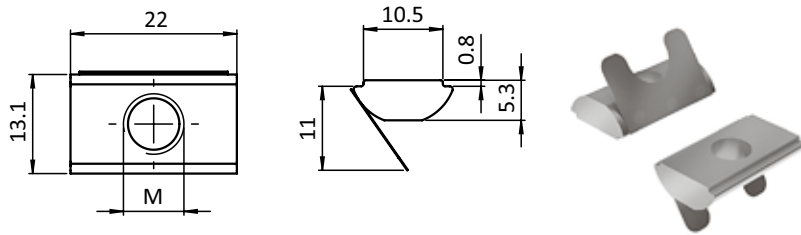

Nutenstein <i>T-slot Nut</i>	Größe <i>Size</i>	Gewicht [g] <i>Weight [g]</i>	Teil-Nr. <i>Part #</i>
	M5	8.8	096145F
	M6	8.5	096146F
	M8	7.8	096148F

Nutmuttern und -schrauben *T-Nuts and T-Bolts*

Nutensteine *T-slot Nuts*

Nut 11 *Slot 11*



NUTENSTEIN 16,4 × 7,0 MM, EINSCHWENKBAR

ROLL-IN-T-SLOT NUT 16.4 × 7.0 MM

Ausführung Nut 11, mit Führungssteg und Federkugel, Stahl
Beschreibung einschwenkbarer Nutenstein mit Führungssteg und Federkugel
Material Nutenstein: Stahl, verzinkt
 Profil: Stahl, blank, ohne Gewinde
 Kugel: Edelstahl
Liefereinheit 100 Stück
Extras ⚡ elektrostatisch entladend, verschiedene Längen mit mehreren Gewinden in unterschiedlichen Größen auf Anfrage

Model Slot 11, self-aligning, with spring loaded ball, steel
Description Self-aligning roll-in T-slot nut with spring loaded ball
Material T-slot nut: Zinc plated steel
 Rod: Steel, plain, without thread
 Ball: Stainless steel
Pack Quantity 100 pieces
Specials ⚡ electrostatically discharging, different lengths with multiple threads in different sizes available on request

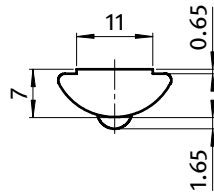
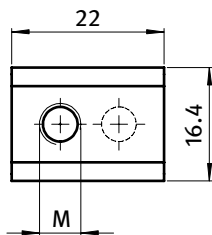

Nutenstein <i>T-slot Nut</i>	Größe <i>Size</i>	Gewicht [g] <i>Weight [g]</i>	Teil-Nr. <i>Part #</i>
	M4	13.6	096074
	M5	13.2	096075
	M6	13.1	096076
	M8	12.1	096078
Profil <i>Rod</i>	1500 mm	1015.5	096070.1500



Nutmuttern und -schrauben *T-Nuts and T-Bolts*

Nutensteine *T-slot Nuts*

Nut 12 *Slot 12*



NUTENSTEIN 20,0 × 10,0 MM, EINSCHWENKBAR

ROLL-IN-T-SLOT NUT 20.0 × 10.0 MM

Ausführung	Nut 12, Stahl	Model	Slot 12, steel
Beschreibung	einschwenkbarer Nutenstein	Description	Roll-in T-slot nut
Material	Stahl, verzinkt	Material	Zinc plated steel
Liefereinheit	100 Stück	Pack Quantity	100 pieces
Extras	⚡ elektrostatisch entladend, verschiedene Längen mit mehreren Gewinden in unterschiedlichen Größen auf Anfrage	Specials	⚡ electrostatically discharging, different lengths with multiple threads in different sizes available on request

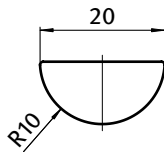
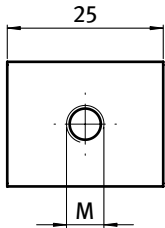

Nutenstein <i>T-slot Nut</i>	Größe <i>Size</i>	Gewicht [g] <i>Weight [g]</i>	Profil <i>Profile</i>	Teil-Nr. <i>Part #</i>
	M6	28.6	I	096176
	M8	27.2	I	096178

Nutmuttern und -schrauben *T-Nuts and T-Bolts*

Nutensteine *T-slot Nuts*

Nut 12 *Slot 12*



NUTENSTEIN 20,0 × 11,2 MM, EINSCHWENKBAR

ROLL-IN-T-SLOT NUT 20.0 × 11.2 MM

Ausführung Nut 12, mit Führungssteg und Federkugel, Stahl
Beschreibung einschwenkbarer Nutenstein mit Führungssteg und Federkugel
Material Nutenstein: Stahl, verzinkt
 Kugel: Edelstahl
Liefereinheit 100 Stück
Extras elektrostatisch entladend, verschiedene Längen mit mehreren Gewinden in unterschiedlichen Größen auf Anfrage

Model Slot 12, self-aligning, with spring loaded ball, steel
Description Self-aligning roll-in T-slot nut with spring loaded ball
Material T-slot nut: Zinc plated steel
 Ball: Stainless steel
Pack Quantity 100 pieces
Specials electrostatically discharging, different lengths with multiple threads in different sizes available on request

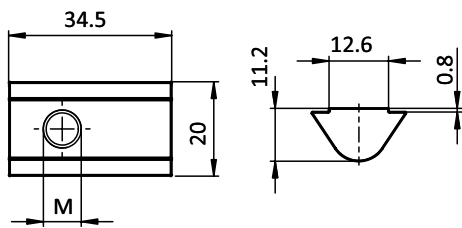

Nutenstein <i>T-slot Nut</i>	Größe <i>Size</i>	Gewicht [g] <i>Weight [g]</i>	Profil <i>Profile</i>	Teil-Nr. <i>Part #</i>
	M6	36.0	I	096986
	M8	35.0	I	096988
	M10	33.0	I	0969810
	M12	30.0	I	0969812



Nutmuttern und -schrauben *T-Nuts and T-Bolts*

Nutensteine *T-slot Nuts*

Nut 12 *Slot 12*



NUTENSTEIN 20,0 × 9,0 MM

T-SLOT NUT 20.0 × 9.0 MM

Ausführung	Nut 12, mit Führungssteg, Stahl	Model	Slot 12, self-aligning, steel
Beschreibung	Nutenstein mit Führungssteg	Description	Self-aligning T-slot nut
Material	Stahl, vernickelt	Material	Nickel plated steel
Liefereinheit	100 Stück	Pack Quantity	100 pieces
Extras	verschiedene Längen mit mehreren Gewinden in unterschiedlichen Größen auf Anfrage	Specials	Different lengths with multiple threads in different sizes available on request

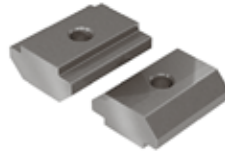
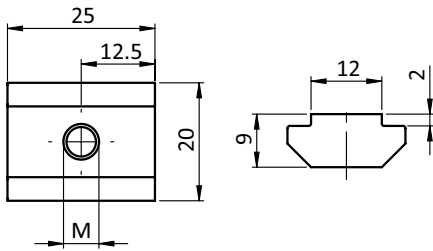

Nutenstein
T-slot Nut

Größe
Size

Gewicht [g]
Weight [g]

Teil-Nr.
Part #

	M6	26.0	096676S01
	M8	25.0	096678S02
	M10	24.0	0966710S01



FEDER FÜR NUTENSTEIN

SPRING FOR T-SLOT NUT

Ausführung	Nut 8 + 10	Model	Slot 8 + 10
Beschreibung	Feder als Montage- und Positionierhilfe, für Nutensteine und einschwenkbare Nutensteine	Description	Spring leaf as mounting and positioning aid, for T-slot nuts and roll-in T-slot nuts
Material	Federstahl 1.4310	Material	Spring steel SS301
Liefereinheit	100 Stück	Pack Quantity	100 pieces

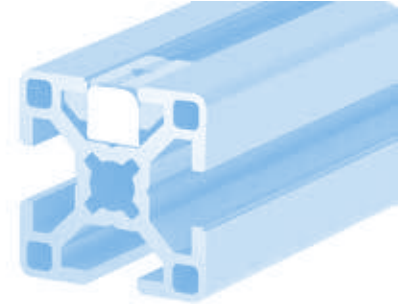
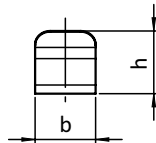
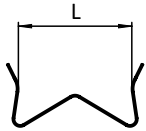

Feder für Nutenstein <i>Spring for T-slot Nut</i>	für Nutenstein L [mm] <i>For T-Slot Nut L [mm]</i>	Gewicht [g] <i>Weight [g]</i>	Profil <i>Profile</i>	Teil-Nr. <i>Part #</i>
Nut 8 <i>Slot 8</i>	16.5	0.4	B	096FN08
Nut 10 <i>Slot 10</i>	20	0.5	B	096FN10

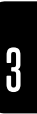

HAMMERMUTTERN UND HAMMERSCHRAUBEN

Um Schraubverbindungen in Nuten herzustellen, können Sie auch Hammermuttern oder Rhombusmuttern verwenden. Dabei wird die Mutter beim Festdrehen der Schraube durch das Drehmoment in der Nut quer gestellt und sicher gehalten.

Bei der Demontage muss die Schraubverbindung nicht ganz gelöst werden, weil sich die Hammermutter beim Aufschrauben sofort längs zur Nut dreht und zusammen mit dem befestigten Teil entnommen werden kann.

HAMMER NUTS AND HAMMER HEAD SCREWS

To make threaded connections in profile slots, you can also use hammer nuts or rhombus nuts. When fixing the nut in place, it will be secured in the slot when it turns into its final position.

When you want to disassemble the connection you do not need to unfasten the whole nut, as it will immediately turn along the profile slot and can be taken out easily.

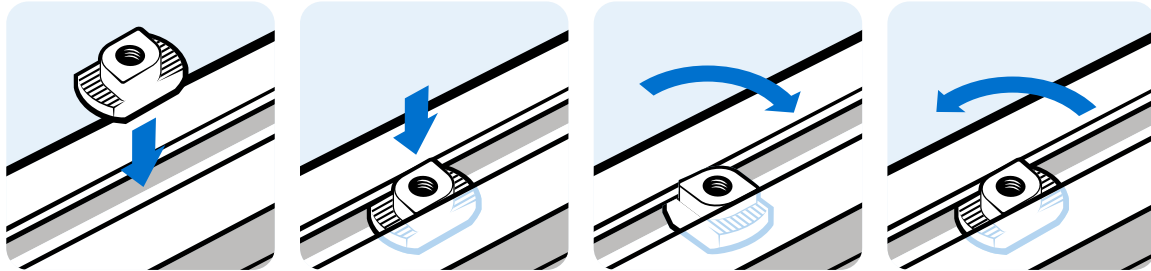

Maßtoleranzen

- B = ± 0,3 mm
- L = ± 0,5 mm
- H = ± 0,2 mm
- H1 = ± 0,3 mm

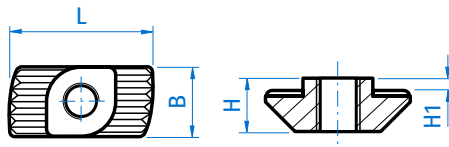

Dimensional Tolerances

- B = ± 0.3 mm
- L = ± 0.5 mm
- H = ± 0.2 mm
- H1 = ± 0.3 mm

Alle Angaben dienen Ihrer Information und stellen keine rechtsverbindliche Zusicherung von Eigenschaften dar.

All information is just for reference and does not pose a legally binding agreement about the product properties.



HAMMERMUTTER

HAMMER NUT

<p>Ausführung Nut 6, Stahl / Edelstahl</p> <p>Beschreibung Befestigungselement für Aluminiumprofile, bricht die Eloxalschicht auf und schafft eine sichere, elektrostatisch entladende Verbindung</p> <p>Material Stahl, verzinkt / Edelstahl 1.4301</p> <p>Liefereinheit 100 Stück</p> <p>Extras Drehhilfe: Gewindeverletzung, Gewindesteigungsfehler oder Polyamid-Fleckbeschichtung auf Anfrage Oberfläche: mit Trocken-Gleitfilm, Zink-Nickel- oder Zink-Lamellen-Überzug auf Anfrage</p>	<p>Model Slot 6, steel / stainless steel</p> <p>Description To fasten components to profiles, breaks the anodized coat of the profile - thus ensuring a safe, electrostatically discharging connection</p> <p>Material Zinc plated steel / stainless steel SS304</p> <p>Pack Quantity 100 pieces</p> <p>Specials Turning help: Dented thread, thread pitch error or polyamide thread locking dot on request Surface: With dry film lubrication, zinc-nickel plated or with zinc lamellar plating on request</p>
---	---

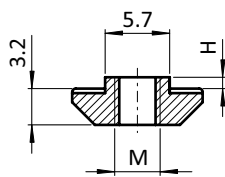
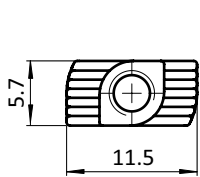

Hammermutter <i>Hammer Nut</i>	H [mm]	Größe <i>Size</i>	Gewicht [g] <i>Weight [g]</i>	Profil <i>Profile</i>	Teil-Nr. <i>Part #</i>
Stahl <i>Steel</i>	1.0	M4	1.0	B	096H06410
Edelstahl <i>Stainless steel</i>	1.0	M4	1.2	B	096H06410E



Nutmuttern und -schrauben *T-Nuts and T-Bolts*

Hammermuttern *Hammer Nuts*

Nut 8 Slot 8



HAMMERMUTTER

HAMMER NUT

<p>Ausführung Nut 8, Stahl</p> <p>Beschreibung Befestigungselement für Aluminiumprofile, bricht die Eloxalschicht auf und schafft eine sichere, elektrostatisch entladende Verbindung</p> <p>Material Stahl, verzinkt</p> <p>Liefereinheit 100 Stück</p> <p>Extras Drehhilfe: Gewindesteigungsfehler oder Polyamid-Fleckbeschichtung auf Anfrage Oberfläche: Zink-Nickel- oder Zink-Lamellen-Überzug auf Anfrage</p>	<p>Model Slot 8, steel</p> <p>Description To fasten components to profiles, brakes the anodized coat of the profile - thus ensuring a safe, electrostatically discharging connection</p> <p>Material Zinc plated steel</p> <p>Pack Quantity 100 pieces</p> <p>Specials Turning help: Thread pitch error or polyamide thread locking dot on request Surface: Zinc-nickel plated or with zinc lamellar plating on request</p>
---	--

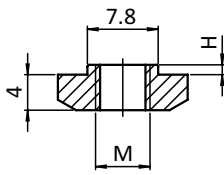
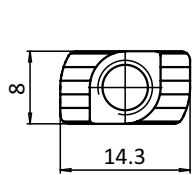

Hammermutter Hammer Nut	H [mm]	Größe Size	Gewicht [g] Weight [g]	Teil-Nr. Part #
Stahl Steel	1.0	M6	2.2	096H08610

Nutmuttern und -schrauben *T-Nuts and T-Bolts*

Hammermuttern *Hammer Nuts*

Nut 8 Slot 8



HAMMERMUTTER

HAMMER NUT

Ausführung	Nut 8, Stahl / Edelstahl	Model	Slot 8, steel / stainless steel
Beschreibung	Befestigungselement für Aluminiumprofile, bricht die Eloxalschicht auf und schafft eine sichere, elektrostatisk entladende Verbindung	Description	To fasten components to profiles, brakes the anodized coat of the profile - thus ensuring a safe, electrostatically discharging connection
Material	Stahl, verzinkt / Edelstahl 1.4401	Material	Zinc plated steel / stainless steel SS316
Liefereinheit	100 Stück	Pack Quantity	100 pieces
Extras	Drehhilfe: Gewindeverletzung, Gewindesteigungsfehler oder Polyamid-Fleckbeschichtung auf Anfrage Oberfläche: mit Trocken-Gleitfilm, Zink-Nickel- oder Zink-Lamellen-Überzug auf Anfrage	Specials	Turning help: Dented thread, thread pitch error or polyamide thread locking dot on request Surface: With dry film lubrication, zinc-nickel plated or with zinc lamellar plating on request

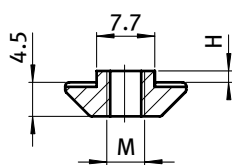
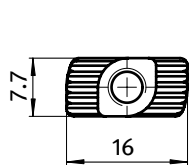

Hammermutter <i>Hammer Nut</i>	H [mm]	Größe <i>Size</i>	Gewicht [g] <i>Weight [g]</i>	Profil <i>Profile</i>	Teil-Nr. <i>Part #</i>
Stahl <i>Steel</i>	1.5	M4	3.8	B	096H08415
	1.5	M5	3.1	B	096H08515
	1.5	M6	3.0	B	096H08615
	1.5	10-32 UNF	3.0	B	096H0810-3215
	3.0	M4	4.5	I	096H08430
	3.0	M5	3.5	I	096H08530
	3.0	M6	3.3	I	096H08630
Edelstahl <i>Stainless steel</i>	1.5	M6	3.1	B	096H08615E



Nutmuttern und -schrauben *T-Nuts and T-Bolts*

Hammermuttern *Hammer Nuts*

Nut 10 Slot 10



HAMMERMUTTER

HAMMER NUT

<p>Ausführung Nut 10, Stahl</p> <p>Beschreibung Befestigungselement für Aluminiumprofile, bricht die Eloxalschicht auf und schafft eine sichere, elektrostatisch entladende Verbindung</p> <p>Material Stahl, verzinkt</p> <p>Liefereinheit 100 Stück</p> <p>Extras Drehhilfe: Gewindeverletzung, Gewindesteigungsfehler oder Polyamid-Fleckbeschichtung auf Anfrage Oberfläche: Zink-Nickel- oder Zink-Lamellen-Überzug auf Anfrage</p>	<p>Model Slot 10, steel</p> <p>Description To fasten components to profiles, brakes the anodized coat of the profile - thus ensuring a safe, electrostatically discharging connection</p> <p>Material Zinc plated steel</p> <p>Pack Quantity 100 pieces</p> <p>Specials Turning help: Dented thread, thread pitch error or polyamide thread locking dot on request Surface: Zinc-nickel plated or with zinc lamellar plating on request</p>
---	--

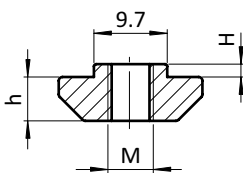
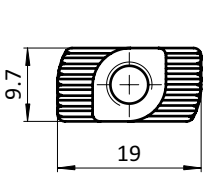

Hammermutter Hammer Nut	H [mm]	Größe Size	Gewicht [g] Weight [g]	Profil Profile	Teil-Nr. Part #
Stahl <i>Steel</i>	1.3	M4	4.7		096H10413S02
	1.3	M5	4.7		096H10513S02
	1.3	M6	4.7		096H10613S02
	1.3	M8	4.7		096H10813S02
	1.5	M5	6.7		096H10517
	1.5	M6	6.2		096H10617
	1.5	M8	5.1		096H10817
	3.0	M4	7.9	B	096H10430
	3.0	M5	7.7	B	096H10530
	3.0	M6	7.2	B	096H10630
3.0	M8	6.1	B	096H10830	
3.0	10-32 UNF	7.6	B	096H1010-3230	



HAMMERMUTTER

HAMMER NUT

Ausführung	Nut 10, Edelstahl	Model	Slot 10, stainless steel
Beschreibung	Befestigungselement für Aluminiumprofile, bricht die Eloxalschicht auf und schafft eine sichere, elektrostatisch entladende Verbindung	Description	To fasten components to profiles, breaks the anodized coat of the profile - thus ensuring a safe, electrostatically discharging connection
Material	Edelstahl 1.4401	Material	Stainless steel SS316
Liefereinheit	100 Stück	Pack Quantity	100 pieces
Extras	Drehhilfe: Gewindeverletzung, Gewindesteigungsfehler oder Polyamid-Fleckbeschichtung auf Anfrage Oberfläche: mit Trocken-Gleitfilm auf Anfrage	Specials	Turning help: Dented thread, thread pitch error or polyamide thread locking dot on request Surface: With dry film lubrication on request

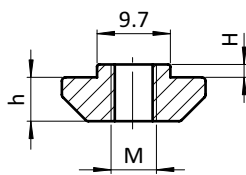
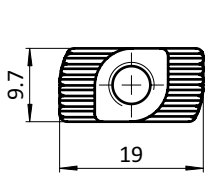

Hammermutter Hammer Nut	H [mm]	Größe Size	Gewicht [g] Weight [g]	Profil Profile	Teil-Nr. Part #
Edelstahl <i>Stainless steel</i>	3.0	M6	7.3	B	096H10630E
	3.0	M8	6.1	B	096H10830E
mit Trocken-Gleitfilm und Gewindeverletzung <i>With dry film lubrication and dented thread</i>	3.0	M6	7.3		096H10630ES03
	3.0	M8	6.1		096H10830ES07
mit Trocken-Gleitfilm <i>With dry film lubrication</i>	3.0	M6	7.3		096H10630ES04
mit Gewindeverletzung <i>With dented thread</i>	3.0	M8	6.3		096H10830ES03



HAMMERSCHRAUBE

HAMMER HEAD SCREW

Ausführung	Nut 8, Stahl / Edelstahl	Model	Slot 8, steel / stainless steel
Beschreibung	Befestigungselement für Aluminiumprofile, bricht die Eloxalschicht auf und schafft eine sichere, elektrisch leitfähige Verbindung	Description	To fasten components to profiles, breaks the anodized coat of the profile - thus ensuring a safe, electrically conductive connection
Material	Stahl, verzinkt / Edelstahl 1.4401	Material	Zinc plated steel / stainless steel SS316
Liefereinheit	100 Stück	Pack Quantity	100 pieces
Extras	Drehhilfe: Polyamid-Fleckbeschichtung auf Anfrage Oberfläche: mit Trocken-Gleitfilm, Zink-Nickel- oder Zink-Lamellen-Überzug auf Anfrage	Specials	Turning help: Polyamide thread locking dot on request Surface: With dry film lubrication, zinc-nickel plated or with zinc lamellar plating on request
Hinweis	passende Flanschmutter siehe Seite 301 * bestehend aus Hammermutter mit geklebtem Gewindestück	Tip	Compatible flange nut see page 301 *Made of hammer nut with glued threaded rod

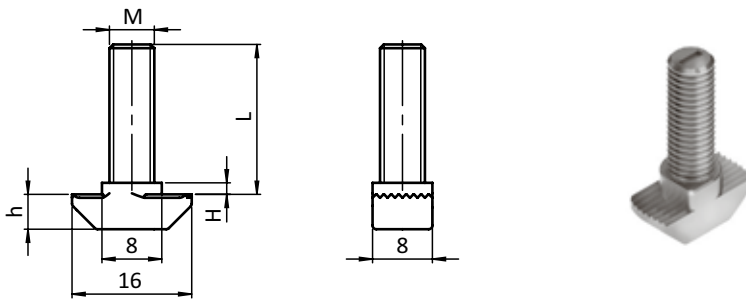

Hammerschraube <i>Hammer Head Screw</i>	H [mm]	Größe M x L [mm] <i>Size M x L [mm]</i>	Gewicht [g] <i>Weight [g]</i>	Profil <i>Profile</i>	Teil-Nr. <i>Part #</i>
Stahl <i>Steel</i>	1.5	M6 x 16	5.3	B	096HK0815M0616
	1.5	M6 x 20	6.2	B	096HK0815M0620
	1.5	M6 x 25	7.0	B	096HK0815M0625
	1.5	*M6 x 30	8.6	B	096HK0815M0630
	1.5	*M6 x 40	10.4	B	096HK0815M0640
	1.5	M6 x 60	13.4	B	096HK0815M0660
	1.5	M8 x 20	9.0	B	096HK0815M0820
	1.5	M8 x 25	10.6	B	096HK0815M0825
	1.5	M8 x 30	12.1	B	096HK0815M0830
	3.0	M6 x 20	5.6	I	096HK0830M0620
	3.0	M6 x 25	6.4	I	096HK0830M0625
	3.0	*M6 x 30	8.0	I	096HK0830M0630
	3.0	*M6 x 40	9.8	I	096HK0830M0640
	3.0	*M6 x 60	12.8	I	096HK0830M0660
	3.0	M8 x 20	9.0	I	096HK0830M0820
3.0	M8 x 25	10.6	I	096HK0830M0825	
3.0	M8 x 30	12.1	I	096HK0830M0830	
3.0	M8 x 40	20.5	I	096HK0830M0840	
Edelstahl <i>Stainless steel</i>	1.5	*M6 x 20	7.6	B	096HK0815M0620E
	1.5	*M6 x 25	8.4	B	096HK0815M0625E
	1.5	*M6 x 30	9.4	B	096HK0815M0630E
	1.5	*M6 x 40	11.2	B	096HK0815M0640E
	1.5	*M6 x 60	14.4	B	096HK0815M0660E



HAMMERSCHRAUBE

HAMMER HEAD SCREW

Ausführung	Nut 10, Stahl	Model	Slot 10, steel
Beschreibung	Befestigungselement für Aluminiumprofile, bricht die Eloxalschicht auf und schafft eine sichere, elektrisch leitfähige Verbindung	Description	To fasten components to profiles, breaks the anodized coat of the profile - thus ensuring a safe, electrically conductive connection
Material	Stahl, verzinkt	Material	Zinc plated steel
Liefereinheit	100 Stück	Pack Quantity	100 pieces
Extras	Drehhilfe: Polyamid-Fleckbeschichtung auf Anfrage Oberfläche: mit Trocken-Gleitfilm, Zink-Nickel- oder Zink-Lamellen-Überzug auf Anfrage	Specials	Turning help: Polyamide thread locking dot on request Surface: With dry film lubrication, zinc-nickel plated or with zinc lamellar plating on request
Hinweis	passende Flanschnutter siehe Seite 301 * bestehend aus Hammermutter mit geklebtem Gewindestück	Tip	Compatible flange nut see page 301 *Made of hammer nut with glued threaded rod

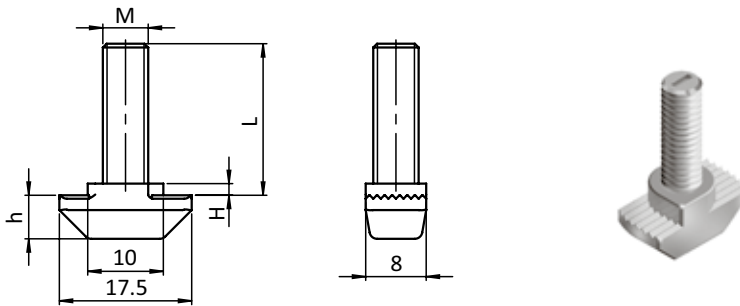

Hammerschraube Hammer Head Screw	B [mm]	H [mm]	Größe M x L [mm] Size M x L [mm]	Gewicht [g] Weight [g]	Profil Profile	Teil-Nr. Part #
	9.7	1.5	*M6 x 20	10.2		096HK1015M0620
	9.7	1.5	*M6 x 25	11.0		096HK1015M0625
	9.7	1.5	*M6 x 30	11.8		096HK1015M0630
	9.7	1.5	*M6 x 40	13.4		096HK1015M0640
	9.7	1.5	*M6 x 60	16.6		096HK1015M0660
	8.0	1.5	M8 x 20	12.7		096HK1015M0820
	8.0	1.5	M8 x 25	14.2		096HK1015M0825
	9.7	1.5	*M8 x 30	15.7		096HK1015M0830
	9.7	1.5	*M8 x 40	18.8		096HK1015M0840
	9.7	1.5	*M8 x 60	24.9		096HK1015M0860
	9.7	3.0	*M6 x 20	11.2	B	096HK1030M0620
	9.7	3.0	*M6 x 25	12.0	B	096HK1030M0625
	9.7	3.0	*M6 x 30	12.8	B	096HK1030M0630
	9.7	3.0	*M6 x 40	14.4	B	096HK1030M0640
	9.7	3.0	*M6 x 60	17.6	B	096HK1030M0660
	8.5	3.0	M8 x 20	13.3	B	096HK1030M0820
	8.5	3.0	M8 x 25	14.8	B	096HK1030M0825
	8.5	3.0	M8 x 30	16.3	B	096HK1030M0830
	8.5	3.0	M8 x 40	19.4	B	096HK1030M0840
	8.5	3.0	M8 x 60	25.5	B	096HK1030M0860
	8.5	4.5	M8 x 20	14.2	B	096HK1045M0820
	8.5	4.5	M8 x 25	14.4	B	096HK1045M0825
	8.5	4.5	M8 x 30	14.6	B	096HK1045M0830





HAMMERSCHRAUBE

HAMMER HEAD SCREW

Ausführung	Nut 10, Edelstahl	Model	Slot 10, stainless steel
Beschreibung	Befestigungselement für Aluminiumprofile, bricht die Eloxalschicht auf und schafft eine sichere, elektrisch leitfähige Verbindung	Description	To fasten components to profiles, breaks the anodized coat of the profile - thus ensuring a safe, electrically conductive connection
Material	Edelstahl 1.4401	Material	Stainless steel SS316
Liefereinheit	100 Stück	Pack Quantity	100 pieces
Extras	Drehhilfe: Polyamid-Fleckbeschichtung auf Anfrage Oberfläche: mit Trocken-Gleitfilm, Zink-Nickel- oder Zink-Lamellen-Überzug auf Anfrage	Specials	Turning help: Thread locking dot on request Surface: With dry film lubrication, zinc plated or with zinc lamellar plating on request
Hinweis	passende Flanschnutter siehe Seite 301 * bestehend aus Hammermutter mit geklebtem Gewindestück	Tip	Compatible flange nut see page 301 *Made of hammer nut with glued threaded rod

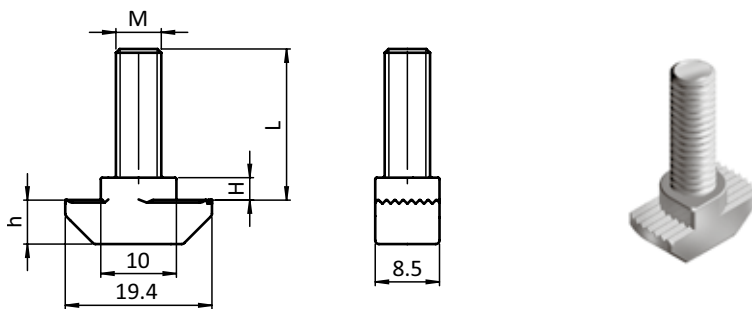

Hammerschraube Hammer Head Screw	H [mm]	Größe M x L [mm] Size M x L [mm]	Gewicht [g] Weight [g]	Profil Profile	Teil-Nr. Part #
	3.0	M6 x 20	11.3	B	096HK1030M0620E
	3.0	M6 x 25	12.1	B	096HK1030M0625E
	3.0	M6 x 30	13.1	B	096HK1030M0630E
	3.0	M6 x 40	14.9	B	096HK1030M0640E
	3.0	M6 x 60	18.1	B	096HK1030M0660E
	3.0	*M8 x 20	13.5	B	096HK1030M0820E
	3.0	*M8 x 25	15.2	B	096HK1030M0825E
	3.0	M8 x 30	16.7	B	096HK1030M0830E
	3.0	M8 x 40	19.9	B	096HK1030M0840E
	3.0	M8 x 60	26.3	B	096HK1030M0860E

FLANSCHMUTTER

FLANGE NUT

Ausführung	Stahl / Edelstahl	Model	Steel / stainless steel
Beschreibung	zur Verwendung in Verbindung mit einer Hammerschraube	Description	To be used in conjunction with a hammer head screw
Material	Stahl, verzinkt / Edelstahl	Material	Zinc plated steel / stainless steel
Liefereinheit	100 Stück	Pack Quantity	100 pieces

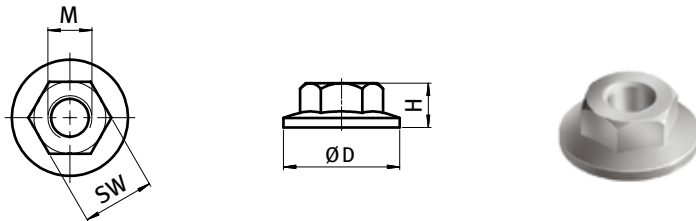

Flanschmutter Flange Nut	D [mm]	H [mm]	M	SW [mm]	Gewicht [g] Weight [g]	Teil-Nr. Part #
Stahl <i>Steel</i>	14.0	6.0	M6	10	3.0	4DIN6923M06M
	21.0	8.0	M8	13	6.0	340ME154
Edelstahl <i>Stainless steel</i>	14.0	6.0	M6	10	3.0	4DIN6923M06E
	17.9	8.0	M8	13	6.0	4DIN6923M08ES02





FEDERMUTTER

SPRING NUT

Ausführung	Nut 8, Stahl	Model	Slot 8, steel
Beschreibung	Befestigungselement für Profilmuttern	Description	To fasten components to profiles
Material	Stahl, verzinkt	Material	Zinc plated steel
Liefereinheit	100 Stück	Pack Quantity	100 pieces

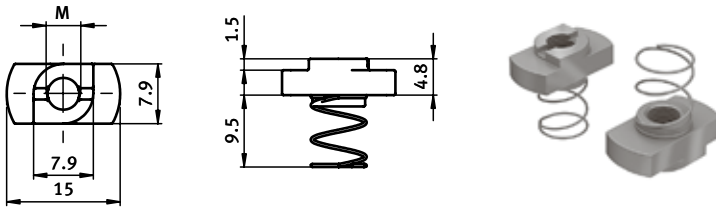

Federmutter Spring Nut	Größe Size	Gewicht [g] Weight [g]	Teil-Nr. Part #
	M4	4.0	096F0804
	M5	3.8	096F0805
	M6	3.6	096F0806



FEDERMUTTER

SPRING NUT

Ausführung	Nut 10, Stahl	Model	Slot 10, steel
Beschreibung	Befestigungselement für Profilmuttern	Description	To fasten components to profiles
Material	Mutter: Stahl, verzinkt Feder: Stahl	Material	Nut: Zinc plated steel Spring: Steel
Liefereinheit	100 Stück	Pack Quantity	100 pieces

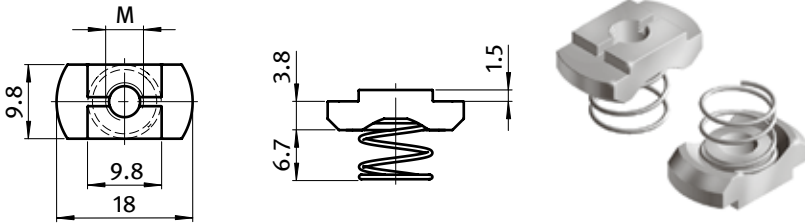

Federmutter <i>Spring Nut</i>	Größe <i>Size</i>	Gewicht [g] <i>Weight [g]</i>	Profil <i>Profile</i>	Teil-Nr. <i>Part #</i>
	M4	5.0	B	096F1004
	M5	4.2	B	096F1005
	M6	4.1	B	096F1006
	M8	3.9	B	096F1008



Nutmuttern und -schrauben *T-Nuts and T-Bolts*
 Rhombus-Nutensteine *Rhombus T-slot Nuts*
 Nut 8 Slot 8



RHOMBUS-NUTENSTEIN

RHOMBUS T-SLOT NUT

Ausführung	Nut 8, Stahl	Model	Slot 8, steel
Beschreibung	Befestigungselement für Profilenuten, verriegelt sich beim Eindrehen in der Nut; mit Führungssteg und Federblech	Description	To fasten components to profiles, locks by turning into the slot; self-aligning, with spring leaf
Material	Stahl, verzinkt	Material	Zinc-plated steel
Liefereinheit	100 Stück	Pack Quantity	100 pieces

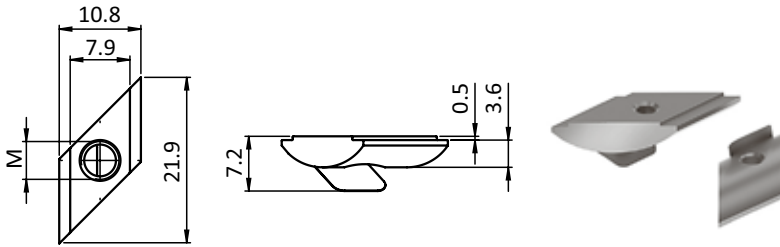

Rhombus-Nutenstein <i>Rhombus T-Slot Nut</i>	Größe <i>Size</i>	Gewicht [g] <i>Weight [g]</i>	Teil-Nr. <i>Part #</i>
	M4	2.6	096R424F
	M5	2.3	096R425F
	M6	2.0	096R426F

Nutmuttern und -schrauben *T-Nuts and T-Bolts*
 Rhombus-Nutensteine *Rhombus T-slot Nuts*
 Nut 8 Slot 8



RHOMBUS-NUTENSTEIN

RHOMBUS T-SLOT NUT

Ausführung	Nut 8, Stahl	Model	Slot 8, steel
Beschreibung	eindrehbarer Nutenstein mit Führungssteg und Federblech	Description	Self-aligning turn-in T-slot nut with spring leaf
Material	Stahl, verzinkt	Material	Zinc-plated steel
Liefereinheit	100 Stück	Pack Quantity	100 pieces
Extras	weitere Größen auf Anfrage	Specials	Other sizes on request

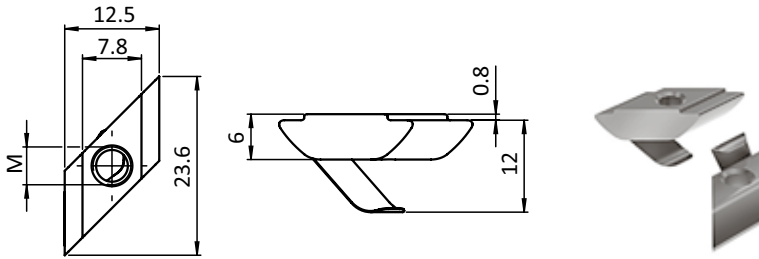

Rhombus-Nutenstein <i>Rhombus T-Slot Nut</i>	Größe <i>Size</i>	Gewicht [g] <i>Weight [g]</i>	Teil-Nr. <i>Part #</i>
	M4	4.8	096R404F
	M5	4.4	096R405F
	M6	4.0	096R406F

3

Nutmuttern und -schrauben *T-Nuts and T-Bolts*

Rhombusmuttern *Rhombus Nuts*

Nut 8 *Slot 8*



RHOMBUSMUTTER

RHOMBUS NUT

Ausführung	Nut 8, Zinkdruckguss	Model	Slot 8, zinc die-cast
Beschreibung	Befestigungselement für Profilmutter, verriegelt sich beim Eindrehen in der Nut	Description	To fasten components to profiles, locks by turning into the slot
Material	Zinkdruckguss, blank	Material	Zinc die-cast, plain
Liefereinheit	100 Stück	Pack Quantity	100 pieces

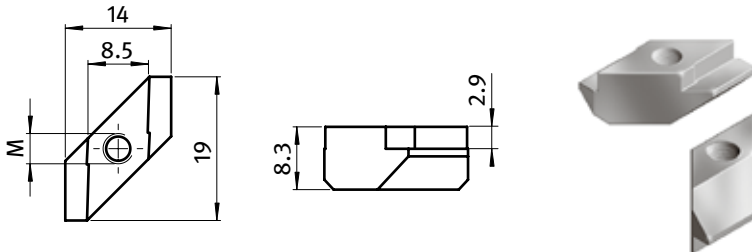

Rhombusmutter <i>Rhombus Nut</i>	Größe <i>Size</i>	Gewicht [g] <i>Weight [g]</i>	Profil <i>Profile</i>	Teil-Nr. <i>Part #</i>
	M3	5.2	I	096R080329Z
	M4	5.0	I	096R080429Z
	M5	4.8	I	096R080529Z
	M6	4.6	I	096R080629Z



RHOMBUSMUTTER

RHOMBUS NUT

Ausführung	Nut 8, Zinkdruckguss	Model	Slot 8, zinc die-cast
Beschreibung	Befestigungselement für Profilmutter, leicht eindrehbar, bleibt in der Nut verschiebbar	Description	To fasten components to profiles, easy to insert, remains mobile in the slot
Material	Zinkdruckguss, blank	Material	Zinc die-cast, plain
Liefereinheit	100 Stück	Pack Quantity	100 pieces

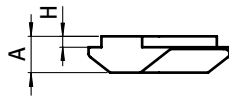
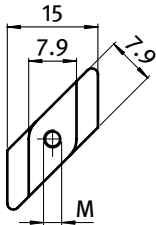

Rhombusmutter <i>Rhombus Nut</i>	A [mm]	H [mm]	Größe <i>Size</i>	Gewicht [g] <i>Weight [g]</i>	Profil <i>Profile</i>	Teil-Nr. <i>Part #</i>
	6.0	1.8	M3	4.1	B	096R080318Z
	6.0	1.8	M4	4.0	B	096R080418Z
	6.0	1.8	M5	3.9	B	096R080518Z
	7.7	3.0	M3	5.1	I	096R080330Z
	7.7	3.0	M4	5.0	I	096R080430Z
	7.7	3.0	M5	4.9	I	096R080530Z





GEWINDEPLATTE

THREADED PLATE

Ausführung	individuelle Maße, ein oder mehrere Gewinde	Model	<i>Customized dimensions, one or several threads</i>
Beschreibung	für jede Befestigung mittels Schraube	Description	<i>To fasten components with a screw</i>
Material	Stahl, verzinkt	Material	<i>Zinc plated steel</i>
Abmessungen	L × B × H	Dimensions	<i>L × B × H</i>
Liefereinheit	100 Stück	Pack Quantity	<i>100 pieces</i>

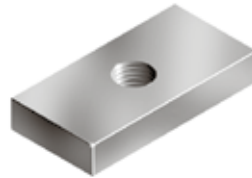
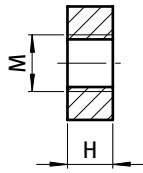
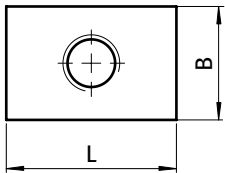

Gewindeplatte <i>Threaded Plate</i>	Gewinde <i>Thread</i>	Maße L × B × H [mm] <i>Dimensions L × B × H [mm]</i>	Gewicht [g] <i>Weight [g]</i>	Profil <i>Profile</i>	Teil-Nr. <i>Part #</i>
	M4	9 × 9 × 3	1.5		096P0090903M4
	M5	9 × 9 × 3	1.2		096P0090903M5
	M6	9 × 9 × 3	1.1		096P0090903M6
	M4	14 × 9 × 2.5	2.2		096P01409025M4
	M5	14 × 9 × 2.5	2.1		096P01409025M5
	M4	14 × 12 × 3	4.0		096P0141203M4
	M5	14 × 12 × 3	3.0		096P0141203M5
	M6	14 × 12 × 3	3.0		096P0141203M6
	M4	15 × 10 × 4	4.1		096P0151004M4
	M5	15 × 10 × 4	3.6		096P0151004M5
	M6	15 × 10 × 4	3.5		096P0151004M6
	M6	15 × 10 × 5	4.8		096P0151005M6
	M4	19 × 16 × 4	8.5	I	096P0191604M4
	M5	19 × 16 × 4	8.3	I	096P0191604M5
	M6	19 × 16 × 4	8.1	I	096P0191604M6
	M8	19 × 16 × 4	7.6	I	096P0191604M8
	M4	19 × 19 × 4	10.0		096P0191904M4
	M5	19 × 19 × 4	10.2		096P0191904M5
	M6	19 × 19 × 4	9.8		096P0191904M6
	M8	19 × 19 × 4	9.1		096P0191904M8



GEWINDEPLATTE

THREADED PLATE

Ausführung	individuelle Maße, ein oder mehrere Gewinde	Model	<i>Customized dimensions, one or several threads</i>
Beschreibung	für jede Befestigung mittels Schraube	Description	<i>To fasten components with a screw</i>
Material	Stahl, verzinkt	Material	<i>Zinc plated steel</i>
Abmessungen	L × B × H	Dimensions	<i>L × B × H</i>
Liefereinheit	100 Stück	Pack Quantity	<i>100 pieces</i>

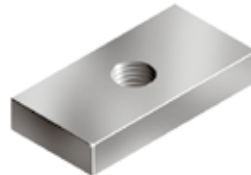
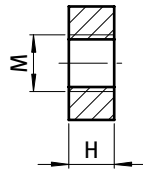
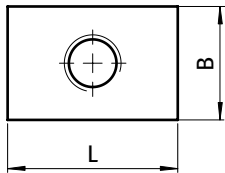

Gewindeplatte <i>Threaded Plate</i>	Gewinde <i>Thread</i>	Maße L × B × H [mm] <i>Dimensions L × B × H [mm]</i>	Gewicht [g] <i>Weight [g]</i>	Profil <i>Profile</i>	Teil-Nr. <i>Part #</i>
	M6	20 × 13 × 5	8.6		096P0201305M6
	M8	20 × 13 × 5	7.8		096P0201305M8
	M8	20 × 14 × 6	10.7		096P0201406M8
	M8	20 × 18 × 6	13.9		096P0201806M8
	M4	20 × 20 × 4	11.4	B	096P0202004M4
	M5	20 × 20 × 4	11.3	B	096P0202004M5
	M6	20 × 20 × 4	11.0	B	096P0202004M6
	M5	20 × 20 × 6	16.5	B	096P0202006M5
	M6	20 × 20 × 6	16.4	B	096P0202006M6
	M8	20 × 20 × 6	16.5	B	096P0202006M8
	M6	22 × 15 × 5	12.2		096P0221505M6
	M6	25 × 12 × 5	9.9		096P0251205M6
	M8	30 × 18 × 8	31.3		096P0301808M8
	M10	30 × 20 × 6	22.8		096P0302006M10
	M8	30 × 25 × 5	27.8		096P0302505M8
	M8	30 × 25 × 6	33.4		096P0302506M8
	M8	32 × 30 × 8	57.8		096P0323008M8
	M6	35 × 30 × 5	40.5		096P0353005M6
	M8	43 × 43 × 5	71.0		096P0434305M8



GEWINDEPLATTE RHOMBUS

THREADED PLATE RHOMBUS

Ausführung individuelle Maße	Model Customized dimensions
Beschreibung für jede Befestigung mittels Schraube	Description To fasten components with a screw
Material Stahl, verzinkt	Material Zinc plated steel
Abmessungen L × B × H	Dimensions L × B × H
Liefereinheit 100 Stück	Pack Quantity 100 pieces

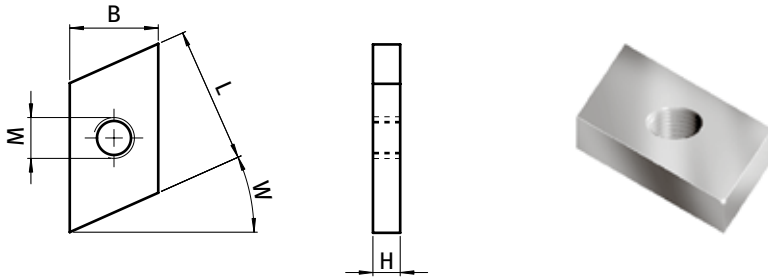

Gewindeplatte Rhombus <i>Threaded Plate Rhombus</i>	Gewinde <i>Thread</i>	Maße L × B × H [mm] <i>Dimensions L × B × H [mm]</i>	Winkel W <i>Angle W</i>	Gewicht [g] <i>Weight [g]</i>	Teil-Nr. <i>Part #</i>
	M8	19 × 13 × 5	30°	9.0	096PR0191305M8
	M6	20 × 13 × 4	24°	7.8	096PR0201304M6
	M8	23 × 15 × 6	30°	15.4	096PR0231506M8



SPREIZMUTTER

SPREAD NUT

Ausführung	Nut 10, PA	Model	Slot 10, PA
Beschreibung	Befestigungselement für Profilmütern	Description	To fasten components to profiles
Material	Kunststoff PA, glasfaserverstärkt	Material	Plastic PA, glass fiber reinforced
Farbe	schwarz	Color	Black
Liefereinheit	100 Stück	Pack Quantity	100 pieces

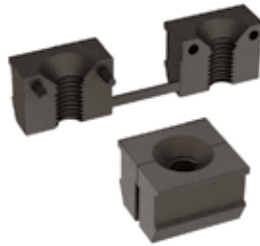
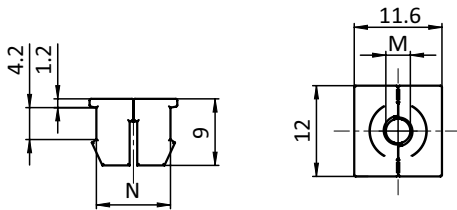







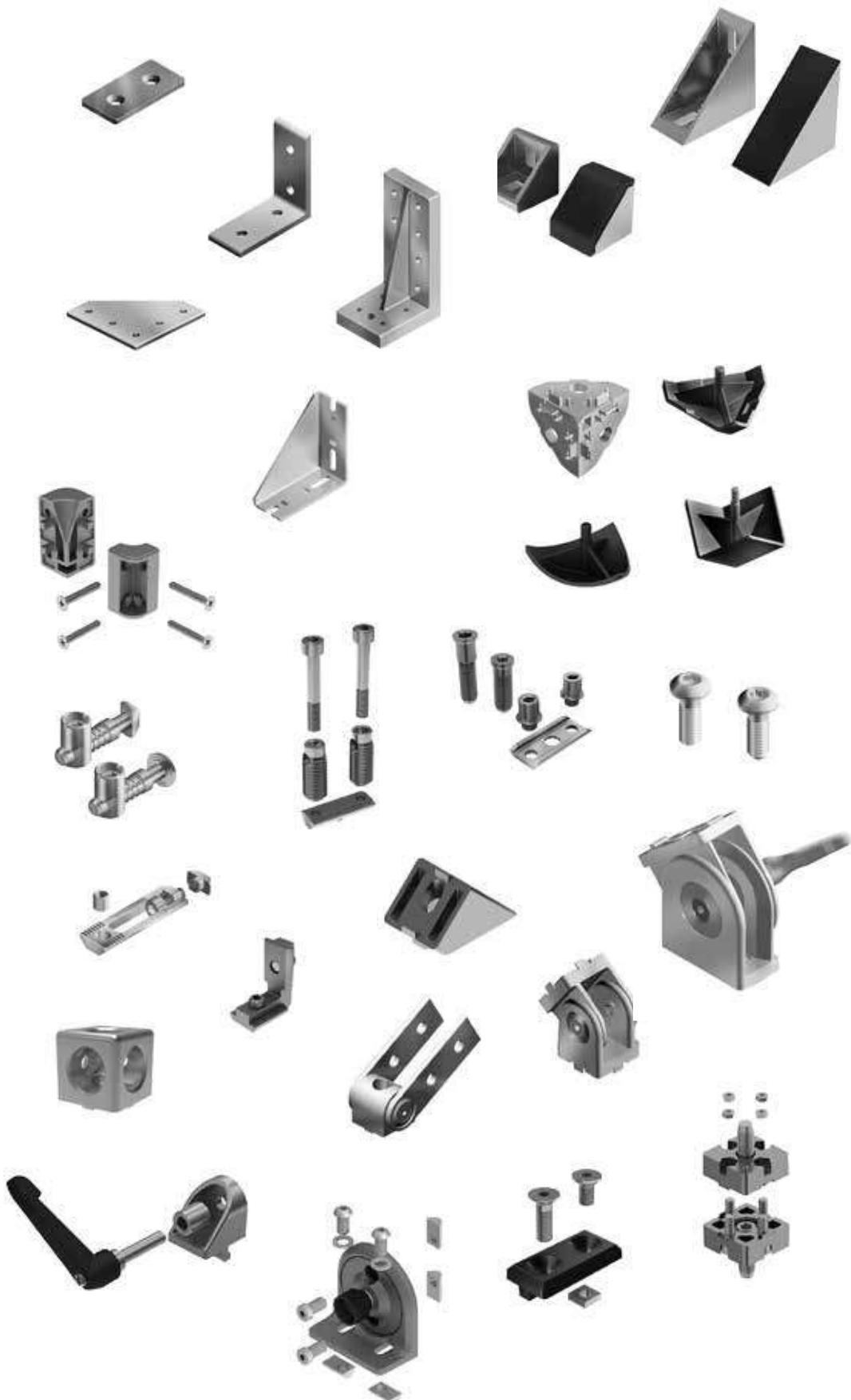

























Spreizmutter <i>Spread Nut</i>	N	Größe <i>Size</i>	Gewicht [g] <i>Weight [g]</i>	Profil <i>Profile</i>	Teil-Nr. <i>Part #</i>
	10	M4	1.00	B	096SM10M04
	10	M5	0.95	B	096SM10M05
	10	M6	0.90	B	096SM10M06



































INHALTSÜBERSICHT *CONTENT OVERVIEW*



























































Bodenelemente <i>Floor Elements</i>	1
Scharniere <i>Hinges</i>	2
Nutmuttern und -schrauben <i>T-Nuts and T-Bolts</i>	3
Verbindungstechnik <i>Connecting Systems</i>	4
Griffe und Verschlüsse <i>Handles and Latches</i>	5
Arbeitsplatzkomponenten <i>Components for Work Stations</i>	6
Gleiter und Rollen <i>Sliders and Rollers</i>	7
Fördertechnik <i>Conveyors</i>	8
Schutz- und Trennwandelemente <i>Enclosures, Guards, Partitions</i>	9
Flächenbefestigungen <i>Panel Fasteners</i>	10
Abdeckelemente <i>Cover Elements</i>	11
Kabelführungen <i>Cable Management</i>	12
Diverse Komponenten <i>Miscellaneous Components</i>	13
Rundrohrkomponenten <i>Tubular Frame Components</i>	14

	Verbinderplatte	Connection Plate	321		Aluwinkel 40/80	Alu Connection Angle 40/80	340
	Verbinderplatte	Connection Plate	322		Aluwinkel 45	Alu Connection Angle 45	341
	Verbinderplatte	Connection Plate	323		Aluwinkel 45 T	Alu Connection Angle 45 T	342
	Verbinderplatte	Connection Plate	324		Aluwinkel 43 x 42	Alu Connection Angle 43 x 42	343
	Verbinderplatte	Connection Plate	325		Aluwinkel 45/90	Alu Connection Angle 45/90	344
	Verbinderplatte	Connection Plate	326		Aluwinkel 60	Alu Connection Angle 60	345
	Verbinderplatte	Connection Plate	327		Aluwinkel 80	Alu Connection Angle 80	346
	Verbinderplatte	Connection Plate	328		Aluwinkel 90	Alu Connection Angle 90	347
	Verbinderplatte	Connection Plate	329		Versteifungswinkel 80 x 180	Support Bracket 80 x 180	348
	Verbinderplatte 100	Connection Plate 100	330		Winkel 20	Connection Angle 20	349
	Verbindungswinkel, 2-loch, 1 Nut	Connection Angle, 2 Bore Holes, 1 Slot Version	331		Winkel 20 x 28	Connection Angle 20 x 28	350
	Verbindungswinkel, 4-loch, 1 Nut	Connection Angle, 4 Bore Holes, 1 Slot Version	332		Winkel 30	Connection Angle 30	351
	Verbindungswinkel, 4-loch, 2 Nuten	Connection Angle, 4 Bore Holes, 2 Slot Version	333		Winkel 40 flach	Connection Angle 40 Flat	352
	Verbindungswinkel, 8-loch, 2 Nuten	Connection Angle, 8 Bore Holes, 2 Slot Version	334		Winkel 40	Connection Angle 40	353
	Aluwinkel 20	Alu Connection Angle 20	335		Verbindungswinkel V 40 (Set)	Connection Angle V 40 (Set)	354
	Aluwinkel 20/40	Alu Connection Angle 20/40	336		Winkel 40/80 flach	Connection Angle 40/80 Flat	355
	Aluwinkel 30	Alu Connection Angle 30	337		Winkel 60	Connection Angle 60	356
	Aluwinkel 30/60	Alu Connection Angle 30/60	338		Winkel 80 flach	Connection Angle 80 Flat	357
	Aluwinkel 40	Alu Connection Angle 40	339		Winkel 80/160	Connection Angle 80/160	358

	Befestigungsnutenstein (Set) für Winkel 80/160	<i>Roll-in T-slot Nut for Connection Angle 80/160</i>	359		Abdeckkappe für Eckwinkel 30	<i>Cover Cap for 3-way Connection Angle 30</i>	378
	Stahlwinkel 30/45	<i>Steel Connection Angle 30/45</i>	360		Abdeckkappe für Eckwinkel 30	<i>Cover Cap for 3-way Connection Angle 30</i>	379
	Stahlwinkel 30/80	<i>Steel Connection Angle 30/80</i>	361		Abdeckkappe für Eckwinkel 30	<i>Cover Cap for 3-way Connection Angle 30</i>	380
	Stahlwinkel 30/100	<i>Steel Connection Angle 30/100</i>	362		Eckwinkel 38 - 1,5"	<i>3-way Connection Angle 38 - 1,5"</i>	381
	Stahlwinkel 45/100	<i>Steel Connection Angle 45/100</i>	363		Abdeckkappe für Eckwinkel 38 - 1,5"	<i>Cover Cap for 3-way Connection Angle 38 - 1.5"</i>	382
	Stahlwinkel 20	<i>Steel Connection Angle 20</i>	364		Abdeckkappe für Eckwinkel 38 - 1,5"	<i>Cover Cap for 3-way Connection Angle 38 - 1.5"</i>	383
	Stahlwinkel 30	<i>Steel Connection Angle 30</i>	365		Eckwinkel 40	<i>3-way Connection Angle 40</i>	384
	Stahlwinkel 40	<i>Steel Connection Angle 40</i>	366		Abdeckkappe für Eckwinkel 40	<i>Cover Cap for 3-way Connection Angle 40</i>	385
	Stahlwinkel 40 Langloch	<i>Steel Connection Angle 40 EH</i>	367		Abdeckkappe für Eckwinkel 40	<i>Cover Cap for 3-way Connection Angle 40</i>	386
	Eckwinkel 20	<i>3-way Connection Angle 20</i>	368		Abdeckkappe für Eckwinkel 40	<i>Cover Cap for 3-way Connection Angle 40</i>	387
	Abdeckkappe für Eckwinkel 20	<i>Cover Cap for 3-way Connection Angle 20</i>	369		Eckwinkel 40	<i>3-way Connection Angle 40</i>	388
	Abdeckkappe für Eckwinkel 20	<i>Cover Cap for 3-way Connection Angle 20</i>	370		Abdeckkappe für Eckwinkel 40	<i>Cover Cap for 3-way Connection Angle 40</i>	389
	Eckwinkel 20	<i>3-way Connection Angle 20</i>	371		Abdeckkappe für Eckwinkel 40	<i>Cover Cap for 3-way Connection Angle 40</i>	390
	Abdeckkappe für Eckwinkel 20	<i>Cover Cap for 3-way Connection Angle 20</i>	372		Eckwinkel 45	<i>3-way Connection Angle 45</i>	391
	Abdeckkappe für Eckwinkel 20	<i>Cover Cap for 3-way Connection Angle 20</i>	373		Abdeckkappe für Eckwinkel 45	<i>Cover Cap for 3-way Connection Angle 45</i>	392
	Eckwinkel 30	<i>3-way Connection Angle 30</i>	374		Abdeckkappe für Eckwinkel 45	<i>Cover Cap for 3-way Connection Angle 45</i>	393
	Abdeckkappe für Eckwinkel 30	<i>Cover Cap for 3-way Connection Angle 30</i>	375		Rahmen-Eckverbinderplatte	<i>Frame Corner Connector Plate</i>	394
	Abdeckkappe für Eckwinkel 30	<i>Cover Cap for 3-way Connection Angle 30</i>	376		Rahmen-Eckverbinder 20 x 40 (Set)	<i>Frame Corner Connector 20 x 40 (Set)</i>	395
	Eckwinkel 30	<i>3-way Connection Angle 30</i>	377		Rahmen-Eckverbinder 22,5 x 45 (Set)	<i>Frame Corner Connector 22.5 x 45 (Set)</i>	396













	Dichtschnur	<i>Sealing Cord</i>	397		Set Anschraubverbinder	<i>Set Screw-on Connector</i>	416
	Würfelverbinder 2D	<i>Cube Connector 2D</i>	398		Selbstformende Senkkopfschraube	<i>Self-forming Countersunk Screw</i>	417
	Würfelverbinder 3D	<i>Cube Connector 3D</i>	399		Selbstformende Halbrundschrabe	<i>Self Forming Button Head Screw</i>	418
	Würfelverbinder 2D	<i>Cube Connector 2D</i>	400		Selbstformende Schraube	<i>Self Forming Screw</i>	419
	Würfelverbinder 3D	<i>Cube Connector 3D</i>	401		Selbstfurchende Schraube	<i>Self-tapping Screw</i>	420
	Würfelverbinder 2D	<i>Cube Connector 2D</i>	402		Verbinderschraube	<i>Connecting Screw</i>	421
	Würfelverbinder 3D	<i>Cube Connector 3D</i>	403		Plattenverbinder	<i>Plate Connector</i>	422
	Würfelverbinder 2D	<i>Cube Connector 2D</i>	404		Plattenverbinder 45	<i>Plate Connector 45</i>	423
	Würfelverbinder 3D	<i>Cube Connector 3D</i>	405		Plattenverbinder 40	<i>Plate Connector 40</i>	424
	Würfelverbinder 2D	<i>Cube Connector 2D</i>	406		Plattenverbinder 40 (Set)	<i>Plate Connector 40 (Set)</i>	425
	Würfelverbinder 3D	<i>Cube Connector 3D</i>	407		Univerbinder	<i>Universal Connector</i>	426
	Bolzenverbinder	<i>Bolt Connector</i>	408		Doppelnutenstein 13,7 x 7,0 mm, einschwenkbar	<i>Roll-in Double T-slot Nut 13.7 x 7.0 mm</i>	427
	Bolzenverbinder	<i>Bolt Connector</i>	409		Univerbinder	<i>Universal Connector</i>	428
	Zentralverbinder	<i>Central Connector</i>	410		Uni-Stoßverbinder	<i>Butt Fastening Universal Connector</i>	429
	Zentralverbinder	<i>Central Connector</i>	411		Automatikverbinder	<i>Automatic Connector</i>	430
	Zentralverbinder	<i>Central Connector</i>	412		Automatikverbinder	<i>Automatic Connector</i>	431
	Zentralverbinder	<i>Central Connector</i>	413		Doppelnutenstein 13,7 x 7,0 mm, einschwenkbar	<i>Roll-in Double T-slot Nut 13.7 x 7.0 mm</i>	432
	Zentralverbinder	<i>Central Connector</i>	414		Automatik-Doppelverbinder (Set)	<i>Automatic Double Connector (Set)</i>	433
	Zentralverbinder	<i>Central Connector</i>	415		Automatik-Stoßverbinder	<i>Automatic Butt Connector</i>	434

	Automatik-Stoßverbinder	<i>Automatic Butt Connector</i>	435		Winkelverbinder 40/20, 45°	<i>Angle Connector 40/20, 45°</i>	454
	Abdeckkappe für Automatikverbinder	<i>Cover Cap for Automatic Connector</i>	436		Winkelverbinder 40/80, 45°	<i>Angle Connector 40/80, 45°</i>	455
	T-Matic Verbinder	<i>T-Matic Connector</i>	437		Winkelverbinder 25 - 1", 45°	<i>Angle Connector 25 - 1", 45°</i>	456
	T-Matic Verbinder	<i>T-Matic Connector</i>	438		Winkelverbinder 51/25 - 2"/1", 45°	<i>Angle Connector 51/25 - 2"/1", 45°</i>	457
	T-Matic Doppelverbinder	<i>T-Matic Double Connector</i>	439		Winkelverbinder 30, 45°	<i>Angle Connector 30, 45°</i>	458
	T-Matic Doppelverbinder	<i>T-Matic Double Connector</i>	440		Winkelverbinder 60/30, 45°	<i>Angle Connector 60/30, 45°</i>	459
	T-Matic Stoßverbinder	<i>T-Matic Butt Connector</i>	441		Winkelverbinder 38 - 1,5", 45°	<i>Angle Connector 38 - 1.5", 45°</i>	460
	Abdeckblech für T-Matic Verbinder	<i>Cover Plate for T-Matic Connector</i>	442		Winkelverbinder 76/38 - 3"/1,5", 45°	<i>Angle Connector 76/38 - 3"/1.5", 45°</i>	461
	Torxschlüssel	<i>Torx Key</i>	443		Winkelverbinder 40, 45°	<i>Angle Connector 40, 45°</i>	462
	Fräsverbinder Profil 30	<i>Milling Connector Profile 30</i>	444		Winkelverbinder 40/80, 45°	<i>Angle Connector 40/80, 45°</i>	463
	Fräsverbinder Profil 40	<i>Milling Connector Profile 40</i>	445		Winkelverbinder 80/40, 45°	<i>Angle Connector 80/40, 45°</i>	464
	Fräsverbinder Profil 45	<i>Milling Connector Profile 45</i>	446		Winkelverbinder 45, 45°	<i>Angle Connector 45, 45°</i>	465
	Schraubenverbinder	<i>Screw Connector</i>	447		Winkelverbinder 90/45, 45°	<i>Angle Connector 90/45, 45°</i>	466
	Schraubenverbinder einseitig	<i>Screw Connector, Single Side</i>	448		Winkelverbinder 30, 45°	<i>Angle Connector 30, 45°</i>	467
	Schraubenverbinder	<i>Screw Connector</i>	449		Winkelverbinder 45, 45°	<i>Angle Connector 45, 45°</i>	468
	Innenverbinder Nut 6	<i>Inner Connector Slot 6</i>	450		Spannverbinder 45°	<i>Clamp connector 45°</i>	469
	Innenverbinder	<i>Inner Connector</i>	451		Gelenk 20	<i>Pivot Joint 20</i>	470
	Innenverbinder R	<i>Inner Connector R</i>	452		Gelenk 20 mit Klemmhebel	<i>Pivot Joint 20 with Locking Lever</i>	471
	Winkelverbinder 20, 45°	<i>Angle Connector 20, 45°</i>	453		Gelenk B 20	<i>Pivot Joint B 20</i>	472



	Gelenk B 20 mit Klemmhebel	<i>Pivot Joint B 20 with Locking Lever</i>	473		Gelenk 45	<i>Pivot Joint 45</i>	492
	Gelenk 20/40	<i>Pivot Joint 20/40</i>	474		Gelenk 45 mit Klemmhebel	<i>Pivot Joint 45 with Locking Lever</i>	493
	Gelenk 20/40 mit Klemmhebel	<i>Pivot Joint 20/40 with Locking Lever</i>	475		Gelenk 45	<i>Pivot Joint 45</i>	494
	Gelenk 25/ 1"	<i>Pivot Joint 25/ 1"</i>	476		Gelenk 45 mit Klemmhebel	<i>Pivot Joint 45 with Locking Lever</i>	495
	Gelenk 25/ 1" mit Klemmhebel	<i>Pivot Joint 25/ 1" with Locking Lever</i>	477		Gelenk 45/90	<i>Pivot Joint 45/90</i>	496
	Gelenk 28/ 1,1"	<i>Pivot Joint 28/ 1.1"</i>	478		Gelenk 45/90 mit Klemmhebel	<i>Pivot Joint 45/90 with Locking Lever</i>	497
	Gelenk 28/ 1,1" mit Klemmhebel	<i>Pivot Joint 28/ 1.1" with Locking Lever</i>	479		Gelenk 180°, 1 Nut	<i>Pivot Joint 180°, 1 Slot Version</i>	498
	Gelenk 30	<i>Pivot Joint 30</i>	480		Gelenk 180°, 2 Nuten	<i>Pivot Joint 180°, 2 Slot Version</i>	499
	Gelenk 30 mit Klemmhebel	<i>Pivot Joint 30 with Locking Lever</i>	481		Schneidhülse	<i>Cutting Bush</i>	500
	Gelenk 30 × 60	<i>Pivot Joint 30 × 60</i>	482		Klemmwinkel 30	<i>Adjustable Angle Clamp 30</i>	501
	Gelenk 30/60 mit Klemmhebel	<i>Pivot Joint 30/60 with Locking Lever</i>	483		Klemmwinkel 30 mit Klemmhebel	<i>Angle Clamp 30 with Locking Lever</i>	502
	Gelenk 38/ 1,5"	<i>Pivot Joint 38/ 1.5"</i>	484		Klemmwinkel 40	<i>Adjustable Angle Clamp 40</i>	503
	Gelenk 38/ 1,5" mit Klemmhebel	<i>Pivot Joint 38/ 1.5" with Locking Lever</i>	485		Klemmwinkel 40 mit Klemmhebel	<i>Angle Clamp 40 with Locking Lever</i>	504
	Gelenk 38/76 - 1,5"/3"	<i>Pivot Joint 38/76 - 1.5"/3"</i>	486		Gelenkwinkel 30	<i>Adjustable Angle 30</i>	505
	Gelenk 38/76 - 1,5"/3" mit Klemmhebel	<i>Pivot Joint 38/76 - 1.5"/3" with Locking Lever</i>	487		Gelenkwinkel 40	<i>Adjustable Angle 40</i>	506
	Gelenk 40	<i>Pivot Joint 40</i>	488		Drehwinkel 30	<i>Turning Angle 30</i>	507
	Gelenk 40 mit Klemmhebel	<i>Pivot Joint 40 with Locking Lever</i>	489		Drehwinkel 45	<i>Turning Angle 45</i>	508
	Gelenk 40/80	<i>Pivot Joint 40/80</i>	490		Winkelfeststellung 40/80 (Set)	<i>Angle Locking Bracket 40/80 (Set)</i>	509
	Gelenk 40/80 mit Klemmhebel	<i>Pivot Joint 40/80 with Locking Lever</i>	491		Schwenkwinkel 130	<i>Pivot Angle 130</i>	510



	Streckenverbinder 50, Nut 8	<i>Connecting Strip 50, slot 8</i>	511
	Set Streckenverbinder 180, Nut 8	<i>Set Connecting Strip 180, slot 8</i>	512
	Set Streckenverbinder 180, Nut 10	<i>Set Connecting Strip 180, slot 10</i>	513
	Verstiftungsnutenstein M6	<i>Pin T-slot Nut M6</i>	514
			515
			516
	Gehrungsverbinder 30°-90°, Nut 10	<i>Mitre Connector 30°-90°, slot 10</i>	517
	Gehrungsverbinder 30°-180°, Nut 10	<i>Mitre Connector 30°-180°, Nut 10</i>	518
	Uni-Gehrungs-Stoßverbinder	<i>Universal Mitre Butt Connector</i>	519
	Gehrungsverbinder 90°	<i>Mitre Connector 90°</i>	520
	Gehrungsverbinder	<i>Mitre Connector</i>	521
	Radiendichtung 40 × 40	<i>Radius Seal 40 × 40</i>	522

VERBINDERPLATTE

CONNECTION PLATE

Ausführung Aluminium	Model Aluminum
Beschreibung zur Verbindung von zwei Aluminiumprofilen	Description To connect two aluminum profiles
Material Aluminium	Material Aluminum
Oberfläche eloxiert	Surface Anodized
Liefereinheit 10 Stück	Pack Quantity 10 pieces
Extras weitere Oberflächen, weitere Farben auf Anfrage	Specials Other surfaces, other colors on request

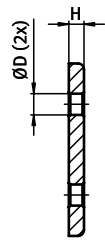
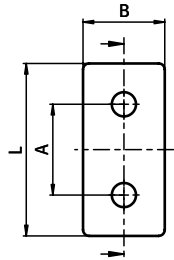

Verbinderplatte Connection Plate	A [mm]	B [mm]	H [mm]	L [mm]	ØD [mm]	Gewicht [g] Weight [g]	Teil-Nr. Part #
20/40	20.0	18.0	4.0	38.0	5.5	7.0	093VA2040
30/60	30.0	27.0	5.0	57.0	7.0	20.0	093VA3060
38/76 - 1.5"/3"	38.1 (1.5")	34.0 (1.34")	6.0	72.0 (2.8")	9.0	37.0	093VA3876
40/80	40.0	36.0	6.0	76.0	9.0	42.0	093VA4080
45/90	45.0	41.0	6.0	86.0	9.0	55.0	093VA4590



VERBINDERPLATTE

CONNECTION PLATE

Ausführung Aluminium	Model <i>Aluminum</i>
Beschreibung zur Verbindung von zwei Aluminiumprofilen	Description <i>To connect two aluminum profiles</i>
Material Aluminium	Material <i>Aluminum</i>
Oberfläche eloxiert	Surface <i>Anodized</i>
Liefereinheit 10 Stück	Pack Quantity <i>10 pieces</i>
Extras weitere Oberflächen, weitere Farben auf Anfrage	Specials <i>Other surfaces, other colors on request</i>

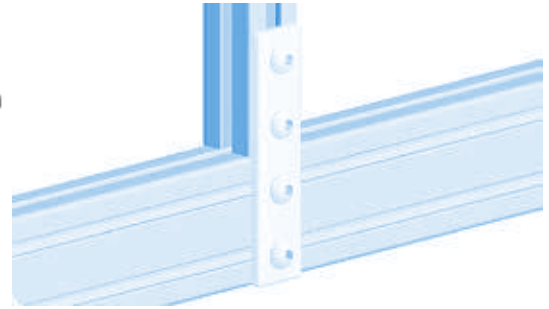
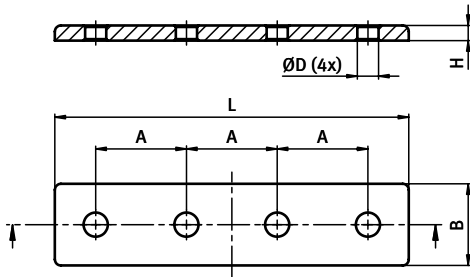

Verbinderplatte <i>Connection Plate</i>	A [mm]	B [mm]	H [mm]	L [mm]	ØD [mm]	Gewicht [g] <i>Weight [g]</i>	Teil-Nr. <i>Part #</i>
20/80	20.0	18.0	4.0	78.0	5.5	15.0	093VA2080
30/120	30.0	27.0	5.0	117.0	7.0	40.0	093VA30120
38/152 - 1.5"/5.98"	38.1 (1.5")	34.0 (1.34")	6.0	148.0 (5.8")	9.0	77.0	093VA38152
40/160	40.0	36.0	6.0	156.0	9.0	86.0	093VA40160
45/180	45.0	41.0	6.0	176.0	9.0	112.0	093VA45180

4

VERBINDERPLATTE

CONNECTION PLATE

Ausführung Aluminium	Model Aluminum
Beschreibung zur Verbindung von zwei Aluminiumprofilen	Description To connect two aluminum profiles
Material Aluminium	Material Aluminum
Oberfläche eloxiert	Surface Anodized
Liefereinheit 10 Stück	Pack Quantity 10 pieces
Extras weitere Oberflächen, weitere Farben auf Anfrage	Specials Other surfaces, other colors on request

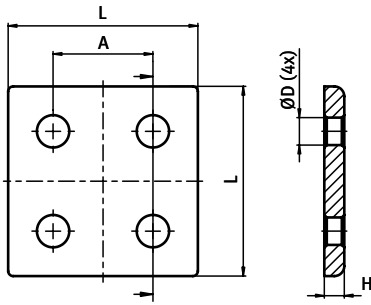

Verbinderplatte Connection Plate	A [mm]	H [mm]	L [mm]	ØD [mm]	Gewicht [g] Weight [g]	Teil-Nr. Part #
40/40	20.0	4.0	38.0	5.5	15.0	093VA4040
60/60	30.0	5.0	57.0	7.0	42.0	093VA6060
76/76 - 3"/3"	38.1 (1.5")	6.0	72.0 (2.8")	9.0	80.0	093VA7676
80/80	40.0	6.0	76.0	9.0	90.0	093VA8080
90/90	45.0	6.0	86.0	9.0	115.0	093VA9090



VERBINDERPLATTE

CONNECTION PLATE

Ausführung Aluminium	Model Aluminum
Beschreibung zur Verbindung von zwei Aluminiumprofilen	Description To connect two aluminum profiles
Material Aluminium	Material Aluminum
Oberfläche eloxiert	Surface Anodized
Liefereinheit 10 Stück	Pack Quantity 10 pieces
Extras weitere Oberflächen, weitere Farben auf Anfrage	Specials Other surfaces, other colors on request

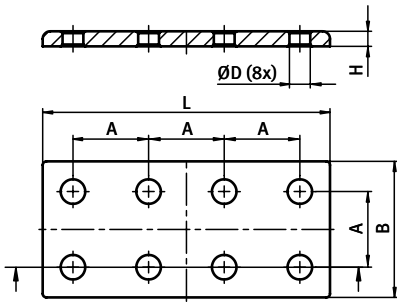

Verbinderplatte Connection Plate	A [mm]	B [mm]	H [mm]	L [mm]	ØD [mm]	Gewicht [g] Weight [g]	Teil-Nr. Part #
40/80	20.0	36.0	4.0	76.0	5.5	27.0	093VD4080
60/120	30.0	57.0	5.0	117.0	7.0	85.0	093VD60120
76/152 - 3"/5.98"	38.1 (1.5")	72.0	6.0	148.0 (5.8")	9.0	164.0	093VD76152
80/160	40.0	76.0	6.0	156.0	9.0	185.0	093VD80160
90/180	45.0	86.0	6.0	176.0	9.0	240.0	093VD90180

4

VERBINDERPLATTE

CONNECTION PLATE

Ausführung	Aluminium	Model	Aluminum
Beschreibung	zur rechtwinkligen Verbindung von zwei Aluminiumprofilen	Description	To connect two aluminum profiles at right angles
Material	Aluminium	Material	Aluminum
Oberfläche	eloxiert	Surface	Anodized
Liefereinheit	10 Stück	Pack Quantity	10 pieces
Extras	weitere Oberflächen, weitere Farben auf Anfrage	Specials	Other surfaces, other colors on request

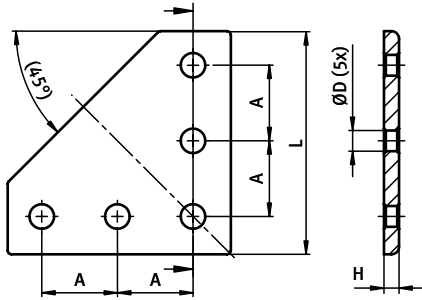

Verbinderplatte Connection Plate	A [mm]	H [mm]	L [mm]	ØD [mm]	Gewicht [g] Weight [g]	Teil-Nr. Part #
60/60	20.0	4.0	59.0	5.5	27.0	093VL6060
90/90	30.0	5.0	88.5	7.0	78.0	093VL9090
114/114 - 4.4"/4.4"	38.1 (1.5")	6.0	112.0 (4.4")	9.0	150.0	093VL114114
120/120	40.0	6.0	118.0	9.0	168.0	093VL120120
135/135	45.0	6.0	133.0	9.0	215.0	093VL135135



VERBINDERPLATTE

CONNECTION PLATE

Ausführung	Aluminium	Model	Aluminum
Beschreibung	zur rechtwinkligen Verbindung von zwei Aluminiumprofilen	Description	To connect two aluminum profiles at right angles
Material	Aluminium	Material	Aluminum
Oberfläche	eloxiert	Surface	Anodized
Liefereinheit	10 Stück	Pack Quantity	10 pieces
Extras	weitere Oberflächen, weitere Farben auf Anfrage	Specials	Other surfaces, other colors on request

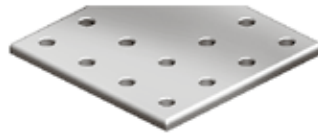
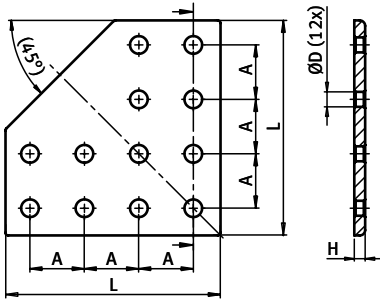

Verbinderplatte Connection Plate	A [mm]	H [mm]	L [mm]	ØD [mm]	Gewicht [g] Weight [g]	Teil-Nr. Part #
80/80	20.0	4.0	79.0	5.5	55.0	093VL8080D
120/120	30.0	5.0	118.5	7.0	158.0	093VL120120D
152/152 - 5.98"/5.98"	38.1 (1.5")	6.0	150.0 (5.9")	9.0	305.0	093VL152152D
160/160	40.0	6.0	158.0	9.0	340.0	093VL160160D
180/180	45.0	6.0	178.0	9.0	435.0	093VL180180D



VERBINDERPLATTE

CONNECTION PLATE

Ausführung	Aluminium	Model	Aluminum
Beschreibung	zum Herstellen einer T-Verbindung zwischen zwei Aluminiumprofilen	Description	To tee connect two aluminum profiles
Material	Aluminium	Material	Aluminum
Liefereinheit	10 Stück	Pack Quantity	10 pieces
Extras	weitere Oberflächen, weitere Farben auf Anfrage	Specials	Other surfaces, other colors on request

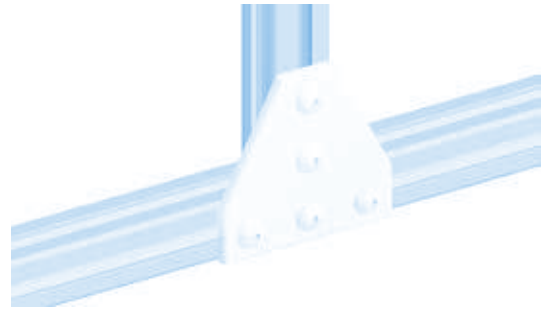
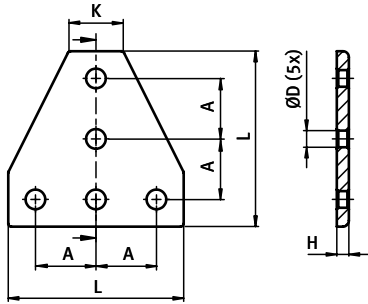

Verbinderplatte <i>Connection Plate</i>	A [mm]	H [mm]	K [mm]	L [mm]	ØD [mm]	Gewicht [g] <i>Weight [g]</i>	Teil-Nr. <i>Part #</i>
60/60	20.0	4.0	18.0	58.0	5.5	27.0	093VT6060
90/90	30.0	5.0	27.0	87.0	7.0	75.0	093VT9090
114/114 - 4.48"/4.48"	38.1 (1.5")	6.0	34.0	110.0	9.0	143.0	093VT114114
120/120	40.0	6.0	36.0	116.0	9.0	160.0	093VT120120
135/135	45.0	6.0	41.0	131.0	9.0	210.0	093VT135135





VERBINDERPLATTE

CONNECTION PLATE

Ausführung	Aluminium	Model	Aluminum
Beschreibung	zum Herstellen einer T-Verbindung zwischen zwei Aluminiumprofilen	Description	To tee connect two aluminum profiles
Material	Aluminium	Material	Aluminum
Oberfläche	eloxiert	Surface	Anodized
Liefereinheit	10 Stück	Pack Quantity	10 pieces
Extras	weitere Oberflächen, weitere Farben auf Anfrage	Specials	Other surfaces, other colors on request

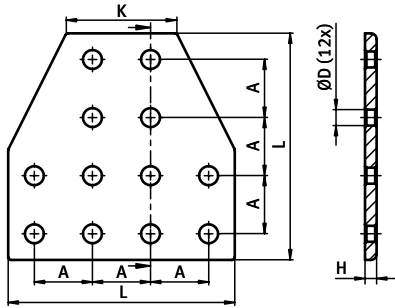

Verbinderplatte Connection Plate	A [mm]	H [mm]	K [mm]	L [mm]	ØD [mm]	Gewicht [g] Weight [g]	Teil-Nr. Part #
80/80	20.0	4.0	38.0	78.0	5.5	55.0	093VT8080D
120/120	30.0	5.0	57.0	117.0	7.0	154.0	093VT120120D
152/152 - 5.98"/5.98"	38.1 (1.5")	6.0	72.0 (2.8")	148.0 (5.8")	9.0	295.0	093VT152152D
160/160	40.0	6.0	76.0	156.0	9.0	330.0	093VT160160D
180/180	45.0	6.0	86.0	176.0	9.0	425.0	093VT180180D



VERBINDERPLATTE

CONNECTION PLATE

Ausführung Stahl, ab Profil 20
Beschreibung zur Verbindung von zwei Aluminiumprofilen
Material Stahl
Befestigung Senkschrauben
Liefereinheit 10 Stück
Extras weitere Oberflächen, weitere Farben auf Anfrage
Hinweis * mit 3 Senkbohrungen
 ** mit 4 Senkbohrungen

Model Steel, profile 20 and up
Description To connect two aluminum profiles
Material Steel
Fastening Countersunk screws
Pack Quantity 10 pieces
Specials Other surfaces, other colors on request
Tip * With 3 countersunk holes
 ** with 4 countersunk holes

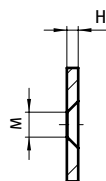
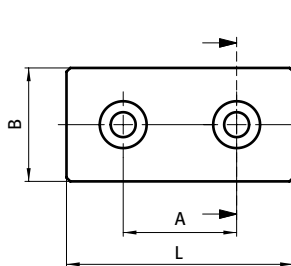

Verbinderplatte Connection Plate	A [mm]	B [mm]	H [mm]	L [mm]	für Schraube for Screw	Gewicht [g] Weight [g]	Teil-Nr. Part #
schwarz pulverbeschichtet Black powder coated	20.0	20.0	3.0	40.0	2x M5	12.0	093V2040S
	30.0	30.0	3.0	60.0	2x M6	36.0	093V3060S
	2x 30.0	30.0	4.0	90.0	3x M6	78.0	* 093V3090S
	40.0	40.0	5.0	80.0	2x M8	116.0	093V4080S
	2x 40.0	40.0	5.0	120.0	3x M8	172.0	* 093V40120S
	3x 40.0	40.0	5.0	160.0	4x M5	223.0	** 093V40160S
blau verzinkt Blue zinc plated	45.0	45.0	5.0	90.0	2x M8	149.0	093V4590S
	30.0	30.0	3.0	60.0	2x M6	36.0	093V3060V
	40.0	40.0	5.0	80.0	2x M8	116.0	093V4080V
	45.0	45.0	5.0	90.0	2x M8	149.0	093V4590V



VERBINDERPLATTE 100

CONNECTION PLATE 100

Ausführung Stahl	Model Steel
Beschreibung zur Verbindung von zwei Aluminiumprofilen	Description To connect two aluminum profiles
Material Stahl	Material Steel
Oberfläche verzinkt	Surface Zinc plated
Liefereinheit 10 Stück	Pack Quantity 10 pieces
Extras weitere Oberflächen, weitere Farben auf Anfrage	Specials Other surfaces, other colors on request

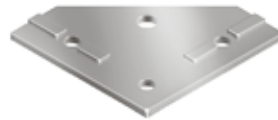
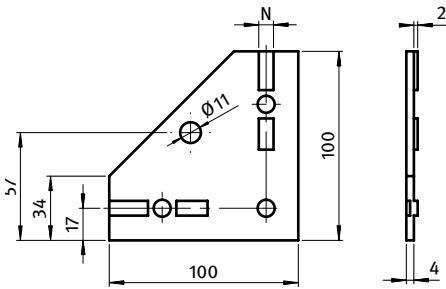

Verbinderplatte 100 Connection Plate 100	N	für Schraube for Screw	Gewicht [g] Weight [g]	Teil-Nr. Part #
	8	M8	219.0	093V1001N08V
	10	M8	221.0	093V1001N10V

4

VERBINDUNGSWINKEL, 2-LOCH, 1 NUT

CONNECTION ANGLE, 2 BORE HOLES, 1 SLOT VERSION

Ausführung	Aluminium	Model	Aluminum
Beschreibung	zur rechtwinkligen Verbindung von zwei Aluminiumprofilen	Description	To connect two aluminum profiles at right angles
Material	Aluminium	Material	Aluminum
Liefereinheit	10 Stück	Pack Quantity	10 pieces

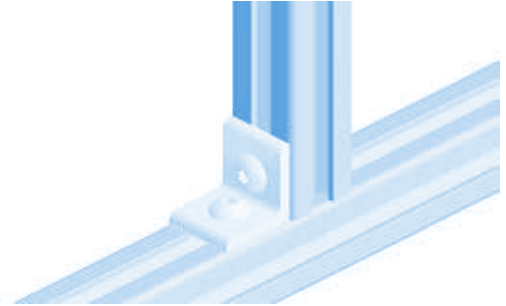
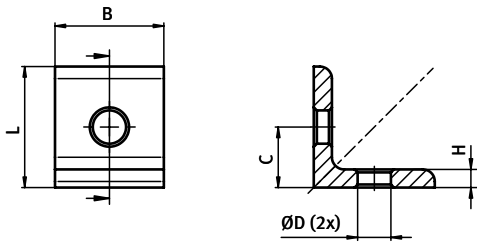

Verbindungswinkel <i>Connection Angles</i>	B [mm]	C [mm]	H [mm]	L [mm]	ØD [mm]	Gewicht [g] <i>Weight [g]</i>	Teil-Nr. <i>Part #</i>
20	18.0	10.0	3.0	20.0	5.5	5.0	093WD20
25 - 1"	25.0 (1")	12.5 (0.5")	4.0	25.0 (1")	7.0	12.0	093WD25
30	30.0	15.0	5.0	30.0	7.0	21.0	093WD30
38 - 1.5"	38.0 (1.5")	19.0 (0.75")	6.0	38.0 (1.5")	9.0	41.0	093WD38
40	36.0	20.0	6.0	40.0	9.0	42.0	093WD40
45	41.0	22.5	6.0	45.0	9.0	55.0	093WD45



VERBINDUNGSWINKEL, 4-LOCH, 1 NUT

CONNECTION ANGLE, 4 BORE HOLES, 1 SLOT VERSION

Ausführung	Aluminium	Model	Aluminum
Beschreibung	zur rechtwinkligen Verbindung von zwei Aluminiumprofilen	Description	To connect two aluminum profiles at right angles
Material	Aluminium	Material	Aluminum
Liefereinheit	10 Stück	Pack Quantity	10 pieces

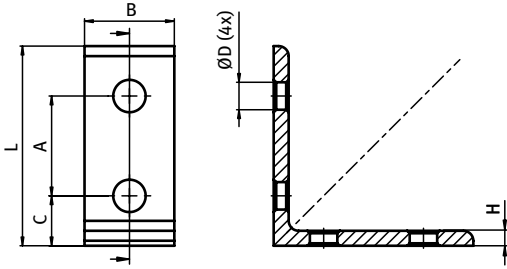

Verbindungswinkel <i>Connection Angles</i>	A [mm]	B [mm]	C [mm]	H [mm]	L [mm]	ØD [mm]	Gewicht [g] <i>Weight [g]</i>	Teil-Nr. <i>Part #</i>
20/40	20.0	18.0	10.0	3.0	40.0	5.5	11.0	093WD2040
25 × 51 - 1" × 2"	25.2 (1")	23.0 (0,91")	12.5 (0.5")	4.0	50.0 (2")	7.0	22.0	093WD2551
30/60	30.0	27.0	15.0	5.0	60.0	7.0	40.0	093WD3060
38/76 - 1.5"/3"	38.1 (1.5")	34.0 (1.34")	19.0 (0.75")	6.0	76.0 (3")	9.0	76.0	093WD3876
40/80	40.0	36.0	20.0	6.0	80.0	9.0	85.0	093WD4080
45/90	45.0	41.0	22.5	6.0	90.0	9.0	112.0	093WD4590

VERBINDUNGSWINKEL, 4-LOCH, 2 NUTEN

CONNECTION ANGLE, 4 BORE HOLES, 2 SLOT VERSION

Ausführung	Aluminium	Model	Aluminum
Beschreibung	zur rechtwinkligen Verbindung von zwei Aluminiumprofilen	Description	To connect two aluminum profiles at right angles
Material	Aluminium	Material	Aluminum
Liefereinheit	10 Stück	Pack Quantity	10 pieces

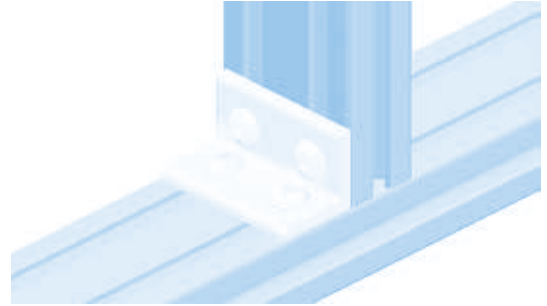
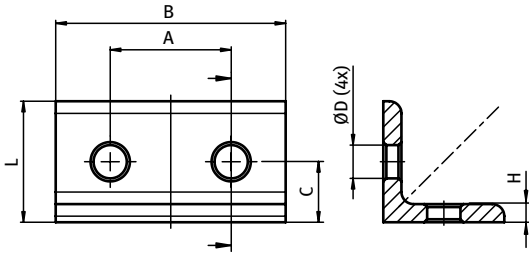

Verbindungswinkel <i>Connection Angles</i>	A [mm]	B [mm]	C [mm]	H [mm]	L [mm]	ØD [mm]	Gewicht [g] <i>Weight [g]</i>	Teil-Nr. <i>Part #</i>
40/20	20.0	38.0	10.0	3.0	20.0	5.5	12.0	093WD4020
60/30	30.0	57.0	15.0	5.0	30.0	7.0	40.0	093WD6030
76/38 - 3"/1.5"	38.1 (1.5")	72.0	19.0 (0.75")	6.0	38.0 (1.5")	9.0	77.0	093WD7638
80/40	40.0	76.0	20.0	6.0	40.0	9.0	86.0	093WD8040
90/45	45.0	86.0	22.5	6.0	45.0	9.0	112.0	093WD9045



VERBINDUNGSWINKEL, 8-LOCH, 2 NUTEN

CONNECTION ANGLE, 8 BORE HOLES, 2 SLOT VERSION

Ausführung Aluminium	Model Aluminum
Beschreibung zur rechtwinkligen Verbindung von zwei Aluminiumprofilen	Description To connect two aluminum profiles at right angles
Material Aluminium	Material Aluminum
Liefereinheit 10 Stück	Pack Quantity 10 pieces

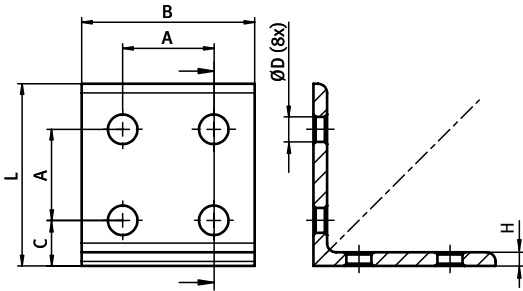

Verbindungswinkel <i>Connection Angles</i>	A [mm]	B [mm]	C [mm]	H [mm]	L [mm]	ØD [mm]	Gewicht [g] <i>Weight [g]</i>	Teil-Nr. <i>Part #</i>
40/40	20.0	38.0	10.0	3.0	40.0	5.5	22.0	093WD4040
60/60	30.0	57.0	15.0	5.0	60.0	7.0	84.0	093WD6060
76/76 - 3"/3"	38.1 (1.5")	72.0 (2.8")	19.0 (0.75")	6.0	76.0 (3")	9.0	161.0	093WD7676
80/80	40.0	76.0	20.0	6.0	80.0	9.0	182.0	093WD8080
90/90	45.0	86.0	22.5	6.0	90.0	9.0	235.0	093WD9090



ALUWINKEL 20

ALU CONNECTION ANGLE 20

Ausführung	Aluminiumdruckguss, ab Profil 20	Model	Aluminum die-cast, profile 20 and up
Beschreibung	zur rechtwinkligen Verbindung von Profilen und Flächenelementen; die offene Seite des Winkels kann durch die Abdeckkappe verschlossen werden	Description	To connect two aluminum profiles or panels at right angles; the connection angle can be closed with the cover cap
Material	Winkel: Aluminiumdruckguss Abdeckkappe: Kunststoff PA, glasfaserverstärkt Montageset: Stahl	Material	Angle: Aluminum die-cast Cover cap: Plastic PA, glass fiber reinforced Assembly set: Steel
Farbe	Abdeckkappe: schwarz	Color	Cover cap: Black
Montageset	2 Hammermuttern - Nut 6 - M4, 2 Schrauben DIN 7984 - M4 × 8	Assembly Set	2 hammer nuts - slot 6 - M4, 2 screws DIN 7984 - M4 × 8
Liefereinheit	10 Stück	Pack Quantity	10 pieces
Extras	weitere Oberflächen, weitere Farben auf Anfrage	Specials	Other surfaces, other colors on request

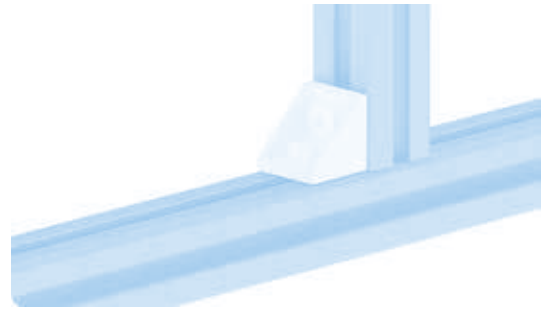
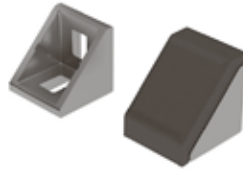
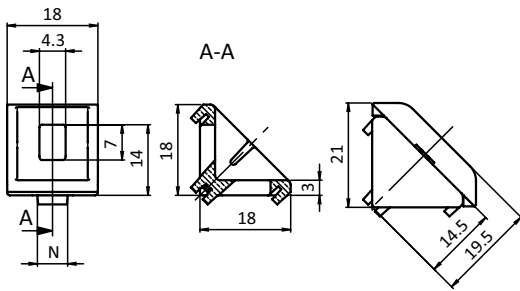

Aluwinkel 20 Alu Connection Angle 20	N	Gewicht [g] Weight [g]	Profil Profile	Teil-Nr. Part #
blank <i>Plain</i>		4.4		093W203
	5	4.6		093W203N05
	6	4.8		093W203N06
alufarbig <i>Alu color</i>	6	4,8		093W203N06S03
Abdeckkappe <i>Cover cap</i>		1.6		093WA203
blank, inkl. Montageset <i>Plain, with assembly set</i>	6	7.0	B	093W203N06S01
alufarbig, inkl. Montageset <i>Alu color, with assembly set</i>	6	12.0	B	093W203N06S04

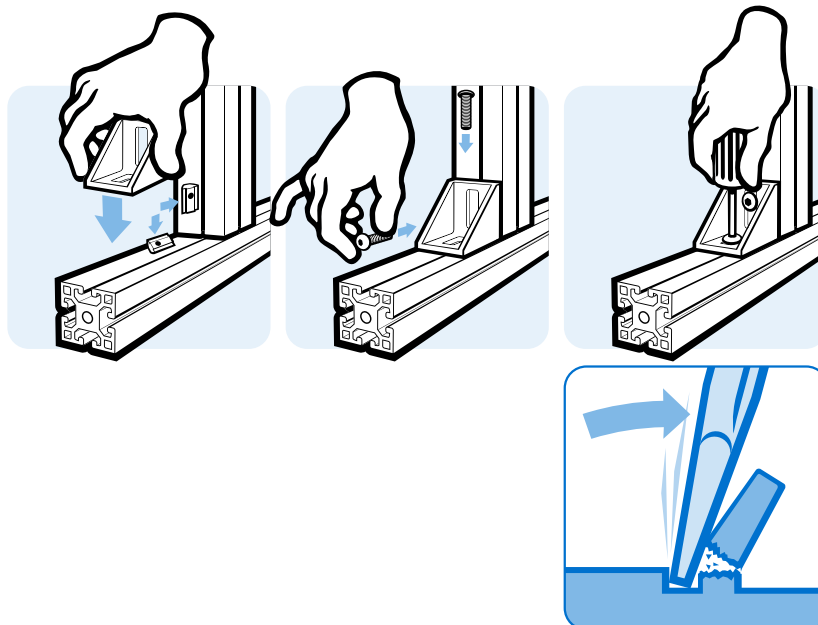



ALUWINKEL 20/40

ALU CONNECTION ANGLE 20/40

Ausführung	Aluminiumdruckguss, ab Profil 20	Model	Aluminum die-cast, profile 20 and up
Beschreibung	zur rechtwinkligen Verbindung von Profilen und Flächenelementen; die offene Seite des Winkels kann durch die Abdeckkappe verschlossen werden	Description	To connect two aluminum profiles or panels at right angles; the connection angle can be closed with the cover cap
Material	Winkel: Aluminiumdruckguss Abdeckkappe: Kunststoff PA, glasfaserverstärkt Montageset: Stahl	Material	Angle: Aluminum die-cast Cover cap: Plastic PA, glass fiber reinforced Assembly set: Steel
Farbe	Abdeckkappe: schwarz	Color	Cover cap: Black
Montageset	4 Hammermuttern - Nut 6 - M4, 4 Schrauben DIN 7984 - M4 × 8	Assembly Set	4 hammer nuts - slot 6 - M4, 4 screws DIN 7984 - M4 × 8
Liefereinheit	10 Stück	Pack Quantity	10 pieces
Extras	weitere Oberflächen, weitere Farben auf Anfrage	Specials	Other surfaces, other colors on request

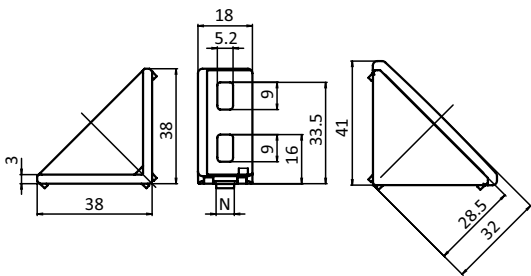

Aluwinkel 20/40 Alu Connection Angle 20/40	N	Gewicht [g] Weight [g]	Profil Profile	Teil-Nr. Part #
blank Plain		13.2		093W202
	5	13.2		093W202N05
	6	13.2		093W202N06
alufarbig Alu color	6	13.4		093W202N06S04
Abdeckkappe Cover cap		1.0		093WA202
blank, inkl. Montageset Plain, with assembly set	6	23.0	B	093W202N06S03
alufarbig, inkl. Montageset Alu color, with assembly set	6	23.2	B	093w202N06S05

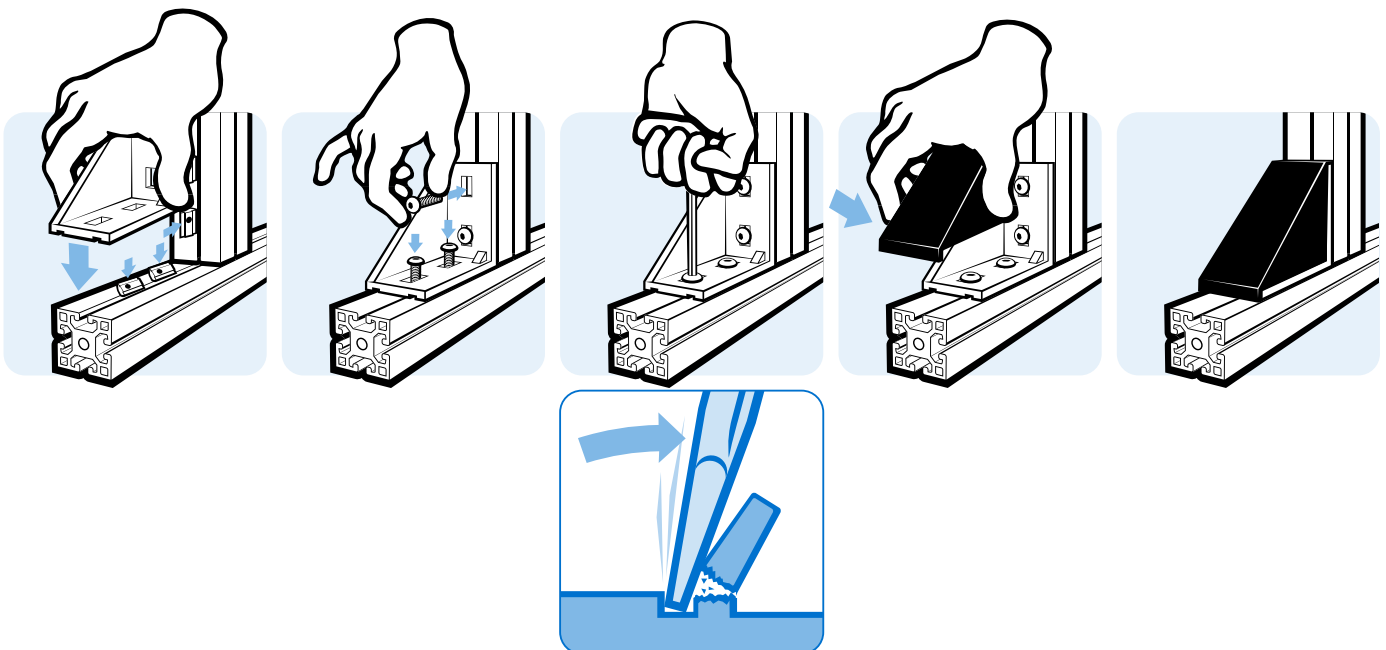



ALUWINKEL 30

ALU CONNECTION ANGLE 30

Ausführung	Aluminiumdruckguss, ab Profil 30	Model	Aluminum die-cast, profile 30 and up
Beschreibung	zur rechtwinkligen Verbindung von Profilen und Flächenelementen; die offene Seite des Winkels kann durch die Abdeckkappe verschlossen werden	Description	To connect two aluminum profiles or panels at right angles; the connection angle can be closed with the cover cap
Material	Winkel: Aluminiumdruckguss Abdeckkappe: Kunststoff PA, glasfaserverstärkt Nutfixierung: Kunststoff PA, glasfaserverstärkt Montageset: Stahl	Material	Angle: Aluminum die-cast Cover Cap: Plastic PA, glass fiber reinforced Centering piece: Nylon PA, glass fiber reinforced Assembly set: Steel
Farbe	Abdeckkappe: schwarz Nutfixierung: schwarz	Color	Cover cap: Black Centering pieces: Black
Montageset 1	2 Hammermüttern - Nut 8 - M6, 2 Schrauben DIN 7984 - M6 x 14	Assembly Set 1	2 hammer nuts - slot 8 - M6, 2 screws DIN 7984 - M6 x 14
Montageset 2	1 Hammermutter - Nut 8 - M6, 1 Schraube DIN 7984 - M6 x 14, 1 Hammermutter - Nut 10 - M6, 1 Schraube DIN 7984 - M6 x 18, 2 Nutfixierungen - Nut 8 auf Nut 10	Assembly Set 2	1 hammer nut - slot 8 - M6, 1 screw DIN 7984 - M6 x 14, 1 hammer nut - slot 10 - M6, 1 screw DIN 7984 - M6 x 18, 2 centering pieces - Slot 8 to slot 10
Montageset 3	2 Hammermüttern - Nut 10 - M6, 2 Schrauben DIN 7984 - M6 x 18, 4 Nutfixierungen - Nut 8 auf Nut 10	Assembly Set 3	2 hammer nuts - slot 10 - M6, 2 screws DIN 7984 - M6 x 18, 4 centering pieces - Nut 8 auf Nut 10
Liefereinheit	10 Stück	Pack Quantity	10 pieces
Extras	weitere Oberflächen, weitere Farben auf Anfrage	Specials	Other surfaces, other colors on request
Hinweis	* mittels 2 Nutfixierungen Nut 8 auf Nut 10	Tip	* By means of two plastic adapters Slot 8 to slot 10

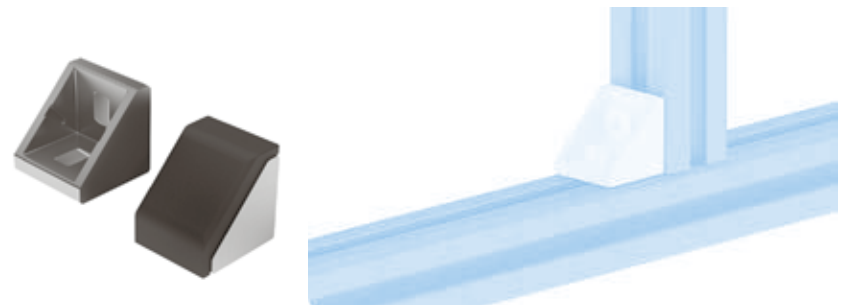
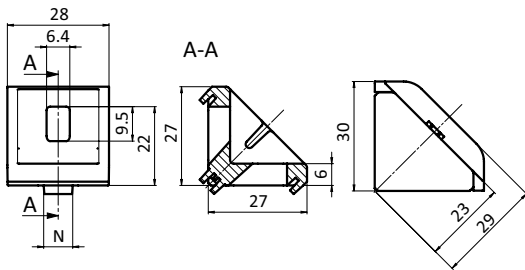

Aluwinkel 30 Alu Connection Angle 30		N	Gewicht [g] Weight [g]	Profil Profile	Teil-Nr. Part #
blank <i>Plain</i>			19.8		093W303
		6	20.4		093W303N06
		8	20.6		093W303N08
		*10	20.8		093W303N10
alufarbig <i>Alu color</i>		8	20.6		093W303N08S12
Nutfixierung <i>Centering pieces</i>	Nut 8 auf Nut 10 <i>Slot 8 to slot 10</i>		1.0		093W02
Abdeckkappe <i>Cover cap</i>			5.2		093WA303S02
blank, inkl. Montageset 1 <i>Plain, with assembly set 1</i>		8	35.0	B	093W303N08S11
blank, inkl. Montageset 2 <i>Plain, with assembly set 2</i>		8 / 10	40.0	B	093W303N08S09
blank, inkl. Montageset 3 <i>Plain, with assembly set 3</i>		10	46.0	B	093W303N10S02
alufarbig, inkl. Montageset 1 <i>Alu color, with assembly set 1</i>		8	48.0	B	093W303N08S13
alufarbig, inkl. Montageset 2 <i>Alu color, with assembly set 2</i>		8 / 10	38.0	B	093W303N08S14
alufarbig, inkl. Montageset 3 <i>Alu color, with assembly set 3</i>		10	46.0	B	093W303N10S03



ALUWINKEL 30/60

ALU CONNECTION ANGLE 30/60

Ausführung	Aluminiumdruckguss, ab Profil 30	Model	Aluminum die-cast, profile 30 and up
Beschreibung	zur rechtwinkligen Verbindung von Profilen und Flächenelementen; die offene Seite des Winkels kann durch die Abdeckkappe verschlossen werden	Description	To connect two aluminum profiles or panels at right angles; the connection angle can be closed with the cover cap
Material	Winkel: Aluminiumdruckguss Abdeckkappe: Kunststoff PA, glasfaserverstärkt Nutfixierung: Kunststoff PA, glasfaserverstärkt Montageset: Stahl	Material	Angle: Aluminum die-cast Cover Cap: Plastic PA, glass fiber reinforced Centering piece: Nylon PA, glass fiber reinforced Assembly set: Steel
Farbe	Abdeckkappe: schwarz Nutfixierung: natur	Color	Cover cap: Black Centering piece: Natural
Montageset	4 Hammermuttern - Nut 8 - M6, 4 Schrauben DIN 7984 - M6 x 14	Assembly Set	4 hammer nuts - slot 8 - M6, 4 screws DIN 7984 - M6 x 14
Liefereinheit	10 Stück	Pack Quantity	10 pieces
Extras	weitere Oberflächen, weitere Farben auf Anfrage	Specials	Other surfaces, other colors on request

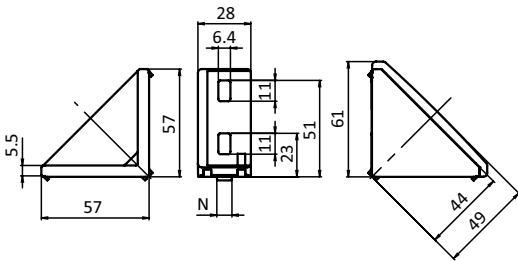

Aluwinkel 30/60
Alu Connection Angle 30/60

	N	Gewicht [g] Weight [g]	Profil Profile	Teil-Nr. Part #
blank <i>Plain</i>		60.0		093W302
	6	60.4		093W302N06
	8	58.5		093W302N08
alufarbig <i>Alu color</i>	8	58.6		093W302N08S04
Nutfixierung <i>Centering pieces</i>	Nut 8 auf Nut 10 <i>Slot 8 to slot 10</i>	1.0		093W02
Abdeckkappe <i>Cover cap</i>		14.0		093WA302
blank, inkl. Montageset <i>Plain, with assembly set</i>	8	82.0	B	093W302N08S01
alufarbig, inkl. Montageset <i>Alu color, with assembly set</i>	8	85.0	B	093W302N08S05

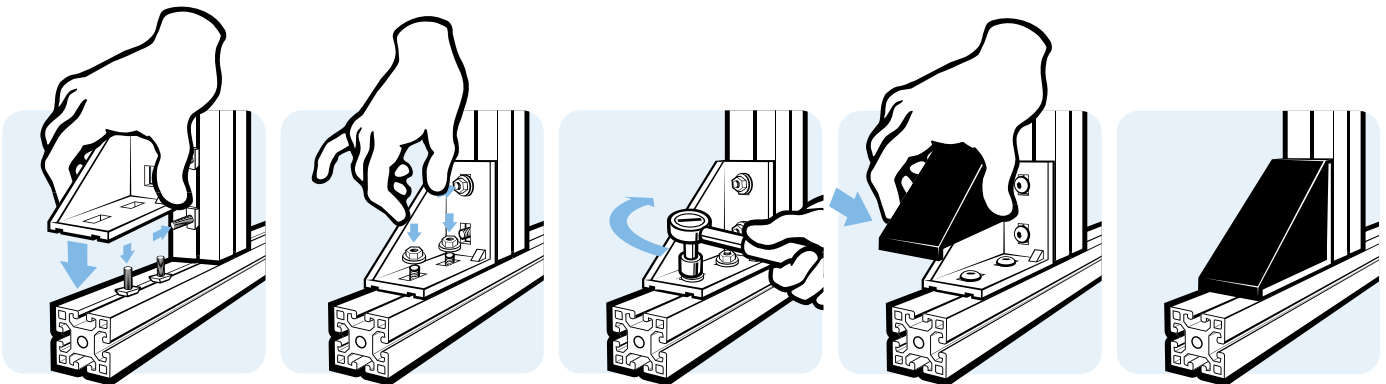



ALUWINKEL 40

ALU CONNECTION ANGLE 40

Ausführung	Aluminiumdruckguss, ab Profil 40	Model	Aluminum die-cast, profile 40 and up
Beschreibung	zur rechtwinkligen Verbindung von Profilen und Flächenelementen; die offene Seite des Winkels kann durch die Abdeckkappe verschlossen werden	Description	To connect two aluminum profiles or panels at right angles; the connection angle can be closed with the cover cap
Material	Winkel: Aluminiumdruckguss Abdeckkappe: Kunststoff PA, glasfaserverstärkt Nutfixierung: Kunststoff PA, glasfaserverstärkt Montageset: Stahl	Material	Angle: Aluminum die-cast Cover Cap: Plastic PA, glass fiber reinforced Centering piece: Nylon PA, glass fiber reinforced Assembly set: Steel
Farbe	Abdeckkappe: schwarz Nutfixierung: natur	Color	Cover cap: Black Centering piece: Natural
Montageset	2 Hammerschrauben - Nut 10 - M8 × 20, 2 Flanschmuttern M8	Assembly Set	2 hammer head screws - slot 10 - M8 × 20, 2 flange nuts M8
Liefereinheit	10 Stück	Pack Quantity	10 pieces
Extras	weitere Oberflächen, weitere Farben auf Anfrage	Specials	Other surfaces, other colors on request

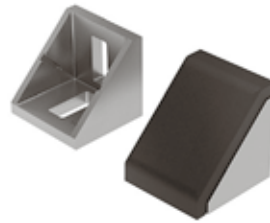
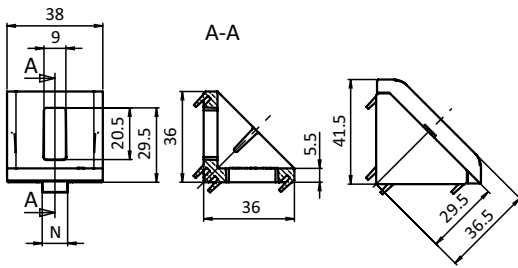

4

Aluwinkel 40 <i>Alu Connection Angle 40</i>	N	Gewicht [g] <i>Weight [g]</i>	Profil <i>Profile</i>	Teil-Nr. <i>Part #</i>
blank <i>Plain</i>		33.0		093W404
	8	33.6		093W404N08
	10	33.8		093W404N10
alufarbig <i>Alu color</i>	10	37.0		093W404N10S05
Nutfixierung <i>Centering pieces</i>	Nut 8 auf Nut 10 <i>Slot 8 to slot 10</i>	1.0		093W03
Abdeckkappe <i>Cover cap</i>		10.6		093WA404
blank, inkl. Montageset <i>Plain, with assembly set</i>	10	76.4	B	093W404N10S01
alufarbig, inkl. Montageset <i>Alu color, with assembly set</i>	10	76.5	B	093W404N10S06

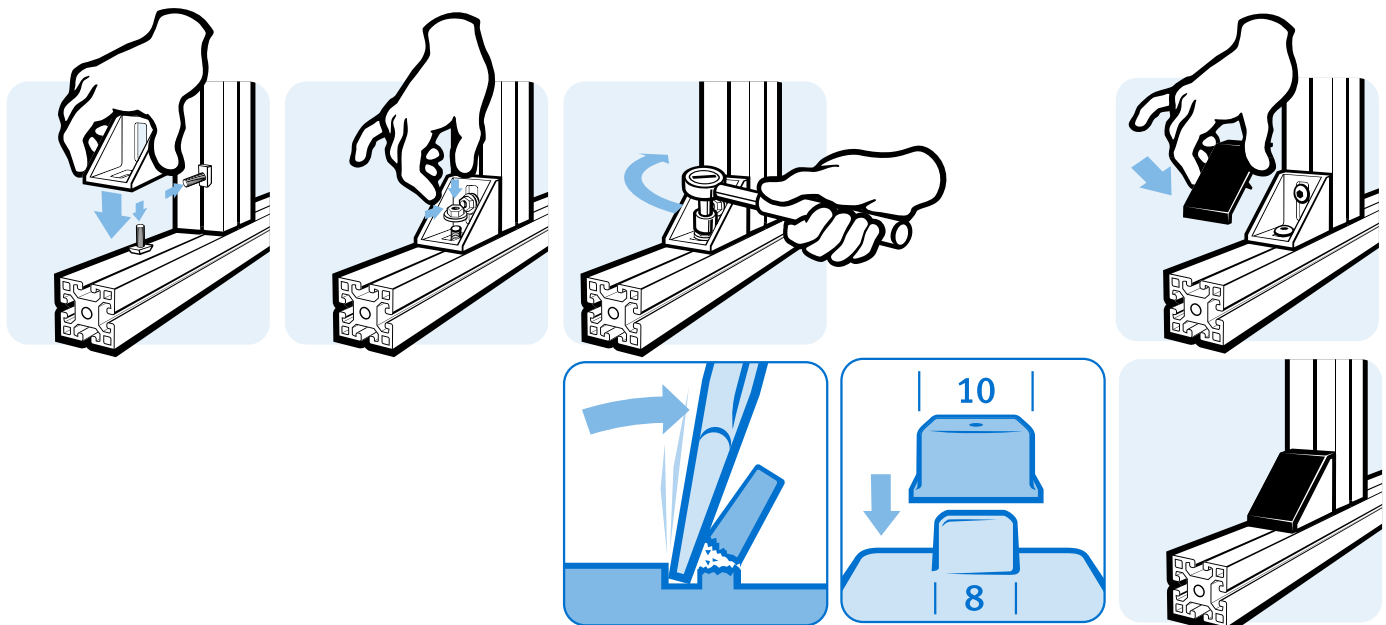



ALUWINKEL 40/80

ALU CONNECTION ANGLE 40/80

Ausführung	Aluminiumdruckguss, ab Profil 40	Model	Aluminum die-cast, profile 40 and up
Beschreibung	zur rechtwinkligen Verbindung von Profilen und Flächenelementen; die offene Seite des Winkels kann durch die Abdeckkappe verschlossen werden	Description	To connect two aluminum profiles or panels at right angles; the connection angle can be closed with the cover cap
Material	Winkel: Aluminiumdruckguss Abdeckkappe: Kunststoff PA, glasfaserverstärkt Montageset: Stahl	Material	Angle: Aluminum die-cast Cover cap: Plastic PA, glass fiber reinforced Assembly set: Steel
Farbe	Abdeckkappe: schwarz	Color	Cover cap: Black
Montageset	4 Hammerschrauben - Nut 10 - M8 × 25, 4 Flanschmuttern M8	Assembly Set	4 hammer head screws - slot 10 - M8 × 25, 4 flange nuts M8
Liefereinheit	10 Stück	Pack Quantity	10 pieces
Extras	weitere Oberflächen, weitere Farben auf Anfrage	Specials	Other surfaces, other colors on request

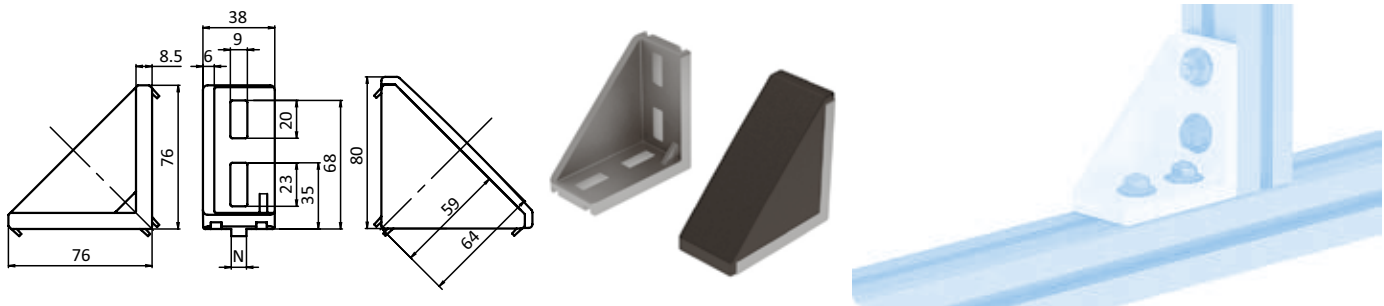

Aluwinkel 40/80 Alu Connection Angle 40/80	N	Gewicht [g] Weight [g]	Profil Profile	Teil-Nr. Part #
blank Plain		123.0		093W403
	8	120.2		093W403N08
	10	118.5		093W403N10
alufarbig Alu color	10	123.0		093W403N10S03
Abdeckkappe Cover cap		87.0		093WA403
blank, inkl. Montageset Plain, with assembly set	10	120.0	B	093W403N10S01
alufarbig, inkl. Montageset Alu color, with assembly set	10	123.0	B	093W403N10S04

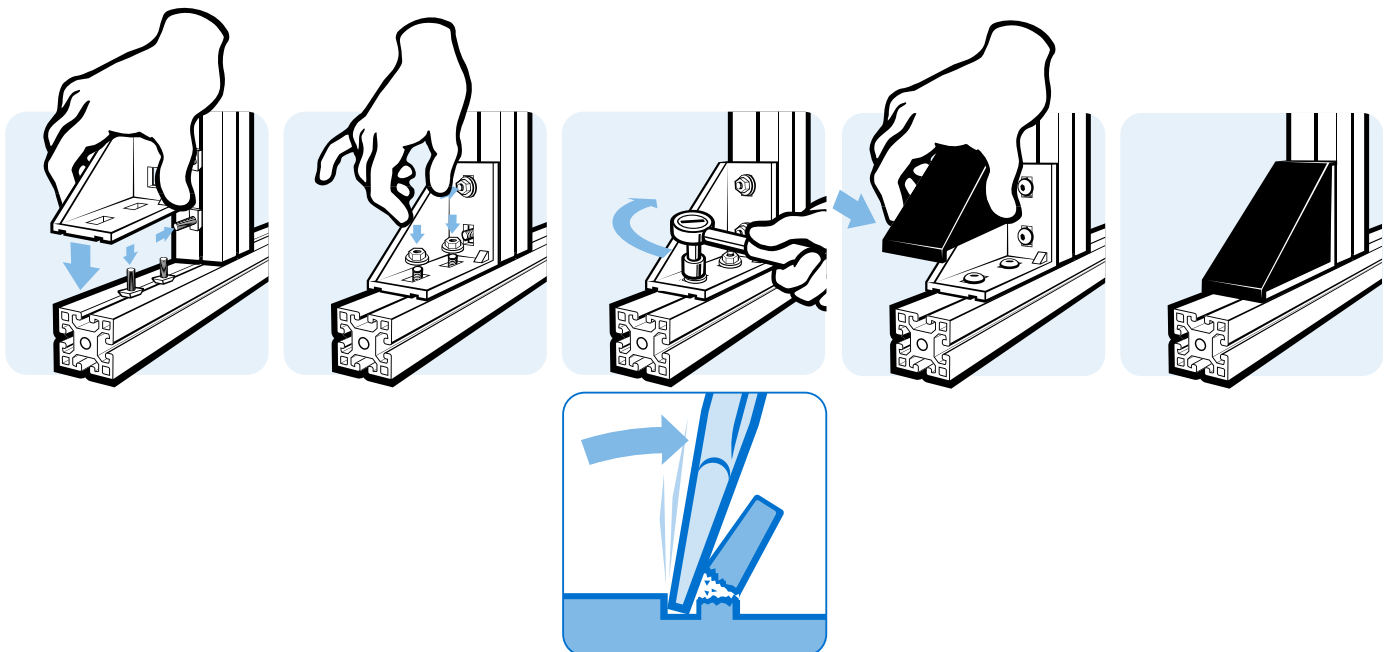



ALUWINKEL 45

ALU CONNECTION ANGLE 45

Ausführung	Aluminiumdruckguss, ab Profil 45	Model	Aluminum die-cast, profile 45 and up
Beschreibung	zur rechtwinkligen Verbindung von Profilen und Flächenelementen; die offene Seite des Winkels kann durch die Abdeckkappe verschlossen werden	Description	To connect two aluminum profiles or panels at right angles; the connection angle can be closed with the cover cap
Material	Winkel: Aluminiumdruckguss Abdeckkappe: Kunststoff PA, glasfaserverstärkt Nutfixierung: Kunststoff PA, glasfaserverstärkt Montageset: Stahl	Material	Angle: Aluminum die-cast Cover cap: Plastic PA, glass fiber reinforced Centering piece: Plastic PA, glass fiber reinforced Assembly set: Steel
Farbe	Abdeckkappe: schwarz, grau Nutfixierung: schwarz	Color	Cover cap: Black, gray Centering piece: Black
Montageset	2 Hammerschrauben - Nut 10 - M8 × 25, 2 Flanschmuttern M8	Assembly Set	2 hammer head screws - slot 10 - M8 × 25, 2 flange nuts M8
Liefereinheit	10 Stück	Pack Quantity	10 pieces
Extras	weitere Oberflächen, weitere Farben auf Anfrage	Specials	Other surfaces, other colors on request

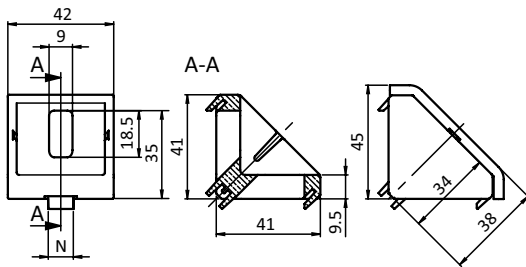

Aluwinkel 45
 Alu Connection Angle 45

	N	Gewicht [g] Weight [g]	Profil Profile	Teil-Nr. Part #
blank <i>Plain</i>		49.5		093W421
	8	50.7		093W421N08
	10	53.6		093W421N10
alufarbig <i>Alu color</i>	10	54.0		093W421N10S08
Nutfixierung <i>Centering pieces</i>	Nut 8 auf Nut 10 <i>Slot 8 to slot 10</i>	1.0		093W02
Abdeckkappe flach schwarz <i>Flat cover cap black</i>		13.8		093WA421S02
blank, inkl. Montageset <i>Plain, with assembly set</i>	10	97.6	B	093W421N10S04
alufarbig, inkl. Montageset <i>Alu color, with assembly set</i>	10	98.0	B	093W421N10S09

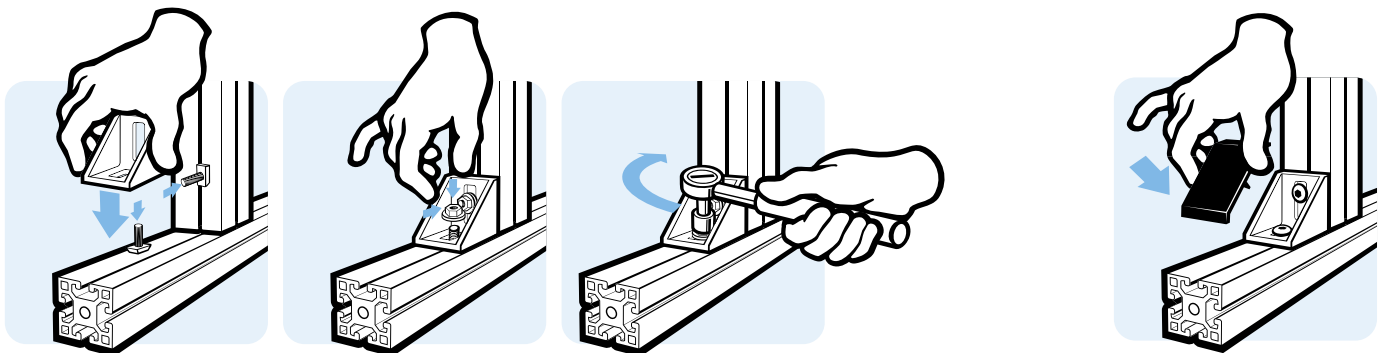



ALUWINKEL 45 T

ALU CONNECTION ANGLE 45 T

Ausführung	Aluminiumdruckguss, ab Profil 48	Model	Aluminum die-cast, profile 45 and up
Beschreibung	zur rechtwinkligen Verbindung von Profilen und Flächenelementen, die offene Seite des Winkels kann durch die Abdeckkappe verschlossen werden	Description	To connect two aluminum profiles or panels at right angles, the connection angle can be closed with the cover cap
Material	Winkel: Aluminiumdruckguss Abdeckkappe: Kunststoff PA, glasfaserverstärkt Montageset: Stahl	Material	Angle: Aluminum die-cast Cover cap: Plastic PA, glass fiber reinforced Assembly set: Steel
Farbe	Abdeckkappe: schwarz, grau	Color	Cover cap: Black, gray
Montageset	2 Hammerschrauben - Nut 10 - M8 x 25, 2 Flanschmuttern M8	Assembly Set	2 hammer screws - slot 10 - M8 x 25, 2 flange nuts M8
Liefereinheit	10 Stück	Pack Quantity	10 pieces
Extras	weitere Oberflächen, weitere Farben auf Anfrage	Specials	Other surfaces, other colors on request

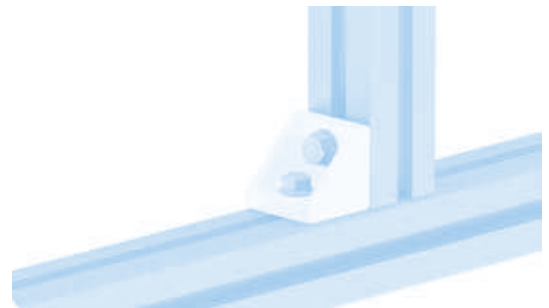
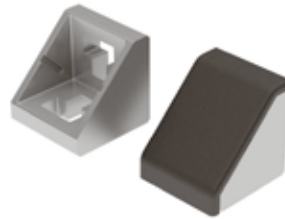
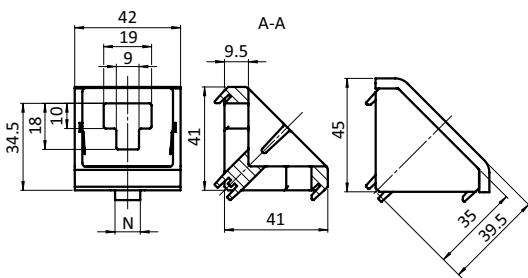

Aluwinkel 45 T Alu Connection Angle 45 T	N	Gewicht [g] Weight [g]	Profil Profile	Teil-Nr. Part #
blank Plain	10	54.3		093W423N10
Abdeckkappe flach schwarz Flat cover cap black		13.8		093WA421S02
inkl. Montageset With assembly set	10	107.6	B	093W423N10S02

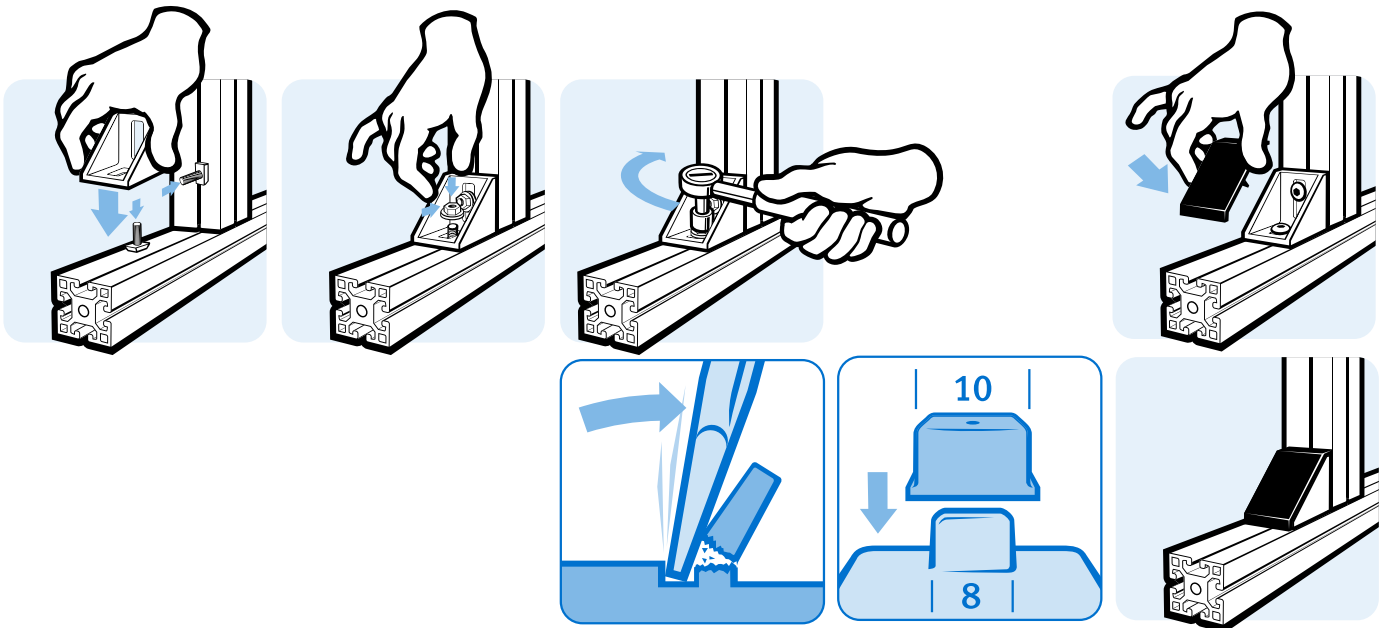



ALUWINKEL 43 × 42

ALU CONNECTION ANGLE 43 × 42

Ausführung	Aluminiumdruckguss, ab Profil 45	Model	Aluminum die-cast, profile 45 and up
Beschreibung	zur rechtwinkligen Verbindung von Profilen und Flächenelementen, die offene Seite des Winkels kann durch die Abdeckkappe verschlossen werden	Description	To connect two aluminum profiles or panels at right angles; the connection angle can be closed with the cover cap
Material	Winkel: Aluminiumdruckguss Abdeckkappe: Kunststoff PA, glasfaserverstärkt Montageset: Stahl	Material	Angle: Aluminum die-cast Cover cap: Plastic PA, glass fiber reinforced Assembly set: Steel
Farbe	Abdeckkappe: schwarz	Color	Cover cap: Black
Montageset	2 Hammerschrauben - Nut 10 - M8 × 25, 2 Flanschmuttern M8	Assembly Set	2 hammer screws - slot 10 - M8 × 25, 2 flange nuts M8
Liefereinheit	10 Stück	Pack Quantity	10 pieces
Extras	weitere Oberflächen, weitere Farben auf Anfrage	Specials	Other surfaces, other colors on request

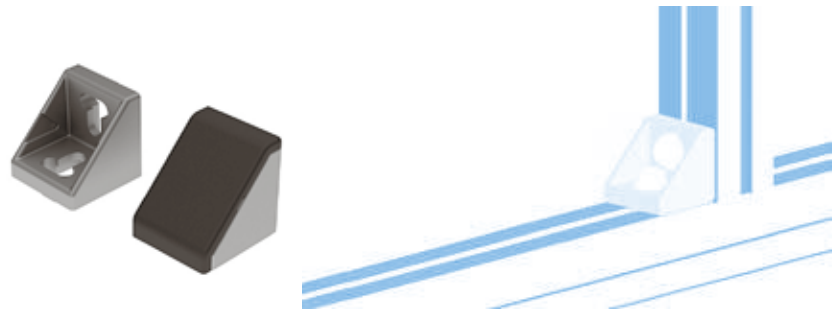
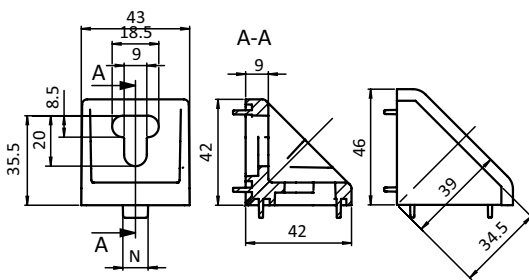

Aluwinkel 43 × 42 Alu Connection Angle 43 × 42	N	Gewicht [g] Weight [g]	Profil Profile	Teil-Nr. Part #
blank <i>Plain</i>	10	54.2		093W422N10
Abdeckkappe <i>Cover cap</i>		9.0		093WA422
inkl. Montageset <i>With assembly set</i>	10	103.0	B	093W422N10S01

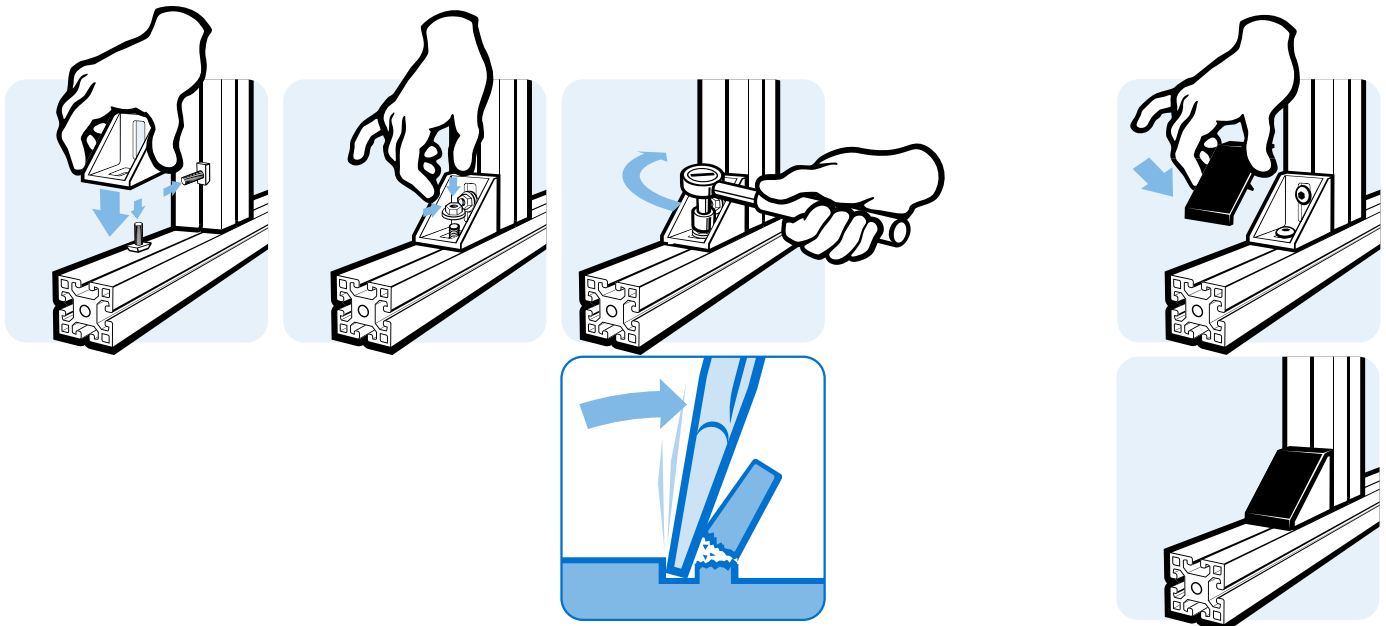



ALUWINKEL 45/90

ALU CONNECTION ANGLE 45/90

Ausführung	Aluminiumdruckguss, ab Profil 45	Model	Aluminum die-cast, profile 45 and up
Beschreibung	zur rechtwinkligen Verbindung von Profilen und Flächenelementen; die offene Seite des Winkels kann durch die Abdeckkappe verschlossen werden	Description	To connect two aluminum profiles or panels at right angles; the connection angle can be closed with the cover cap
Material	Winkel: Aluminiumdruckguss Abdeckkappe: Kunststoff PA, glasfaserverstärkt Nutfixierung: Kunststoff PA, glasfaserverstärkt Montageset: Stahl	Material	Angle: Aluminum die-cast Cover cap: Plastic PA, glass fiber reinforced Centering piece: Plastic PA, glass fiber reinforced Assembly set: Steel
Farbe	Abdeckkappe: schwarz Nutfixierung: natur	Color	Cover cap: Black Centering piece: Natural
Montageset	4 Hammerschrauben - M8 x 25, 4 Flanschmuttern M8	Assembly Set	4 hammer head screws - M8 x 25, 4 flange nuts M8
Liefereinheit	10 Stück	Pack Quantity	10 pieces
Extras	weitere Oberflächen, weitere Farben auf Anfrage	Specials	Other surfaces, other colors on request

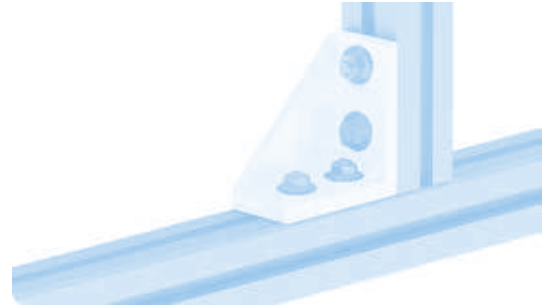
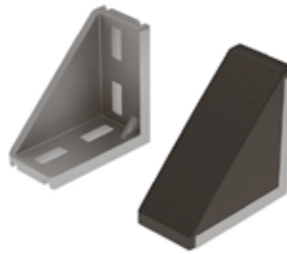
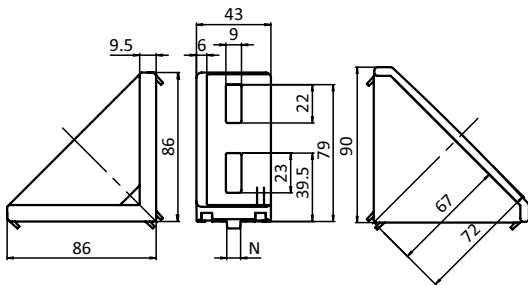

Aluwinkel 45/90
Alu Connection Angle 45/90

	N	Gewicht [g] Weight [g]	Profil Profile	Teil-Nr. Part #
blank <i>Plain</i>		161.5		093W451
	8	163.0		093W451N08
	10	165.0		093W451N10
alufarbig <i>Alu color</i>	10	166.0		093W451N10S05
Nutfixierung <i>Centering pieces</i>	Nut 8 auf Nut 10 <i>Slot 8 to slot 10</i>	1.0		093W03
Abdeckkappe <i>Cover cap</i>		33.5		093WA451
blank, inkl. Montageset <i>Plain, with assembly set</i>	10	254.0	B	093W451N10S01
alufarbig, inkl. Montageset <i>Alu color, with assembly set</i>	10	255.0	B	093W451N10S06

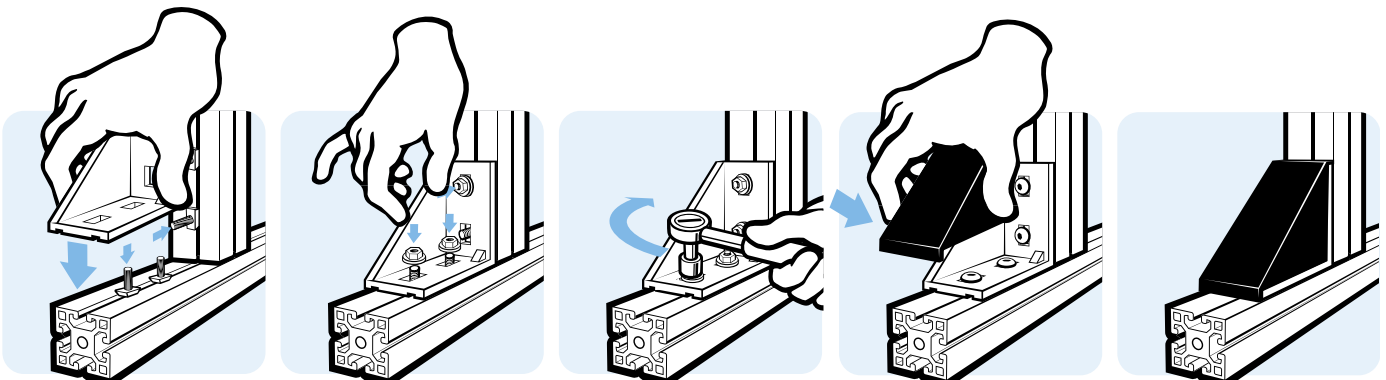



ALUWINKEL 60

ALU CONNECTION ANGLE 60

Ausführung	Aluminiumdruckguss, ab Profil 60	Model	Aluminum die-cast, profile 60 and up
Beschreibung	zur rechtwinkligen Verbindung von Profilen und Flächenelementen; die offene Seite des Winkels kann durch die Abdeckkappe verschlossen werden	Description	To connect two aluminum profiles or panels at right angles; the connection angle can be closed with the cover cap
Material	Winkel: Aluminiumdruckguss Abdeckkappe: Kunststoff PA, glasfaserverstärkt Nutfixierung: Kunststoff PA, glasfaserverstärkt Montageset: Stahl	Material	Angle: Aluminum die-cast Cover cap: Plastic PA, glass fiber reinforced Centering piece: Plastic PA, glass fiber reinforced Assembly set: Steel
Farbe	Abdeckkappe: schwarz Nutfixierung: schwarz	Color	Cover cap: Black Centering piece: Black
Montageset 2	4 Hammermuttern - Nut 8 - M6, 4 Schrauben DIN 7984 - M6 x 14, 1 Hammerschraube - Nut 10 - M8 x 20, 1 Flanschmutter - M8, 2 Nutfixierungen - Nut 8 auf Nut 10	Assembly Set 2	4 hammer nuts - Nut 8 - M6, 4 screws DIN 7984 - M6 x 14, 1 hammer screw - Nut 10 - M8 x 20, 1 flange nut - M8, 2 plastic adapters - Slot 8 to slot 10
Montageset 3	2 Hammerschrauben - M8 x 20, 2 Flanschmutter M8	Assembly Set 3	2 hammer head screws - M8 x 20, 2 flange nuts - M8
Liefereinheit	10 Stück	Pack Quantity	10 pieces
Extras	weitere Oberflächen, weitere Farben auf Anfrage	Specials	Other surfaces, other colors on request

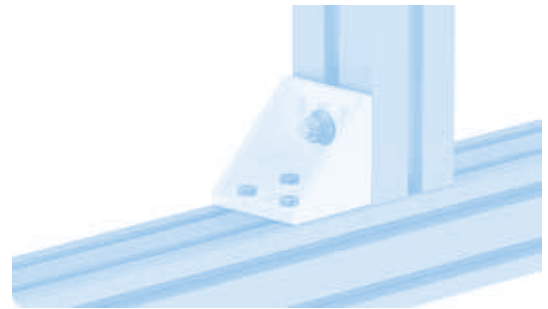
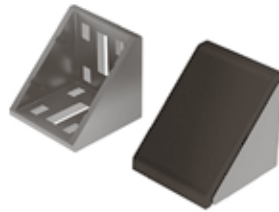
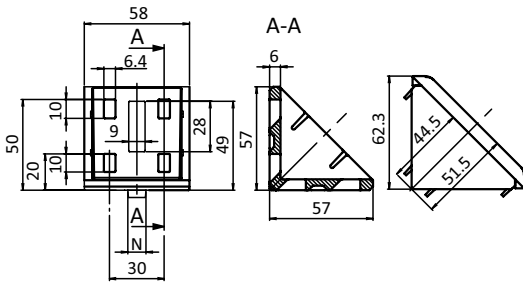

Aluwinkel 60 Alu Connection Angle 60		N	Gewicht [g] Weight [g]	Profil Profile	Teil-Nr. Part #
blank <i>Plain</i>			103.0		093W603
		8	106.0		093W603N08
		10	109.0		093W603N10
alufarbig <i>Alu color</i>		8	107.0		093W603N08S03
		10	111.0		093W603N10S04
Nutfixierung <i>Centering pieces</i>	Nut 8 auf Nut 10 <i>Slot 8 to slot 10</i>		1.0		093W02
Abdeckkappe <i>Cover cap</i>			25.8		093WA603
blank, inkl. Montageset 1 <i>Plain, with assembly set 1</i>		8	172.0	B	093W603N08S01
blank, inkl. Montageset 2 <i>Plain, with assembly set 2</i>		8	160.0	B	093W603N08S02
blank, inkl. Montageset 3 <i>Plain, with assembly set 3</i>		10	155.0	B	093W603N10S01
alufarbig, inkl. Montageset 1 <i>Alu color, with assembly set1</i>		8	174.0	B	093W603N08S04
alufarbig, inkl. Montageset 2 <i>Alu color, with assembly set2</i>		8	160.0	B	093W603N08S05
alufarbig, inkl. Montageset 3 <i>Alu color, with assembly set3</i>		10	142.0	B	093W603N10S03



ALUWINKEL 80

ALU CONNECTION ANGLE 80

Ausführung	Aluminiumdruckguss, ab Profil 80	Model	Aluminum die-cast, profile 80 and up
Beschreibung	zur rechtwinkligen Verbindung von Profilen und Flächenelementen; die offene Seite des Winkels kann durch die Abdeckkappe verschlossen werden	Description	To connect two aluminum profiles or panels at right angles; the connection angle can be closed with the cover cap
Material	Winkel: Aluminiumdruckguss Abdeckkappe: Kunststoff PA, glasfaserverstärkt Nutfixierung: Kunststoff PA, glasfaserverstärkt Montageset: Stahl	Material	Angle: Aluminum die-cast Cover cap: Plastic PA, glass fiber reinforced Centering piece: Plastic PA, glass fiber reinforced Assembly set: Steel
Farbe	Abdeckkappe: schwarz Nutfixierung: schwarz	Color	Cover cap: Black Centering piece: Black
Montageset	8 Hammerschrauben - Nut 10 - M8 x 25, 8 Flanschmuttern M8	Assembly Set	8 hammer head screws - slot 10 - M8 x 25, 8 flange nuts M8
Liefereinheit	10 Stück	Pack Quantity	10 pieces
Extras	weitere Oberflächen, weitere Farben auf Anfrage	Specials	Other surfaces, other colors on request

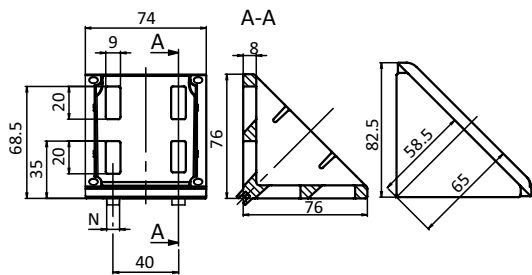

Aluwinkel 80 <i>Alu Connection Angle 80</i>	N	Gewicht [g] <i>Weight [g]</i>	Profil <i>Profile</i>	Teil-Nr. <i>Part #</i>
blank <i>Plain</i>		212.0		093W806
	8	220.0		093W806N08
	10	225.0		093W806N10
alufarbig <i>Alu color</i>	10	227.0		093W806N10S03
Nutfixierung <i>Centering pieces</i>	Nut 8 auf Nut 10 <i>Slot 8 to slot 10</i>	1.0		093W02
Abdeckkappe <i>Cover cap</i>		42.0		093WA806
blank, inkl. Montageset <i>Plain, with assembly set</i>	10	412.0	B	093W806N10S01
alufarbig, inkl. Montageset <i>Alu color, with assembly set</i>	10	408.0	B	093W806N10S04

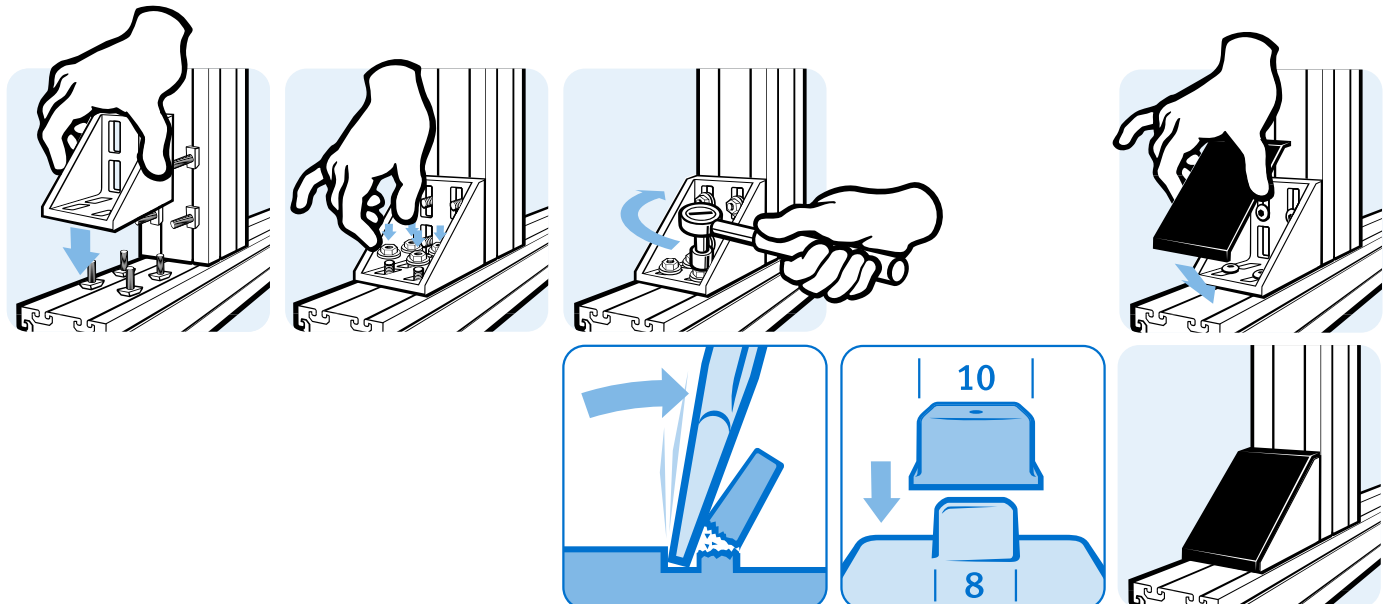



ALUWINKEL 90

ALU CONNECTION ANGLE 90

Ausführung	Aluminiumdruckguss, ab Profil 90	Model	Aluminum die-cast, profile 90 and up
Beschreibung	zur rechtwinkligen Verbindung von Profilen und Flächenelementen; die offene Seite des Winkels kann durch die Abdeckkappe verschlossen werden	Description	To connect two aluminum profiles or panels at right angles; the connection angle can be closed with the cover cap
Material	Winkel: Aluminiumdruckguss Abdeckkappe: Kunststoff PA, glasfaserverstärkt Nutfixierung: Kunststoff PA, glasfaserverstärkt Montageset: Stahl	Material	Angle: Aluminum die-cast Cover cap: Plastic PA, glass fiber reinforced Centering piece: Plastic PA, glass fiber reinforced Assembly set: Steel
Farbe	Abdeckkappe: schwarz Nutfixierung: schwarz	Color	Cover cap: Black Centering piece: Black
Montageset	8 Hammerschrauben M8 × 25, 8 Flanschmuttern M8	Assembly Set	8 hammer head screws - M8 × 25, 8 flange nuts M8
Liefereinheit	10 Stück	Pack Quantity	10 pieces
Extras	weitere Oberflächen, weitere Farben auf Anfrage	Specials	Other surfaces, other colors on request

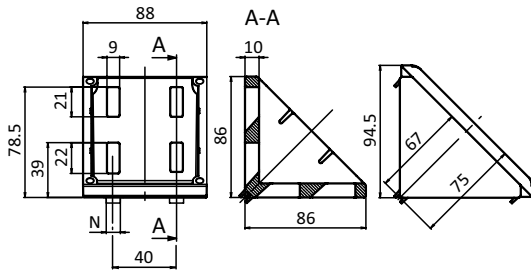

Aluwinkel 90
 Alu Connection Angle 90

	N	Gewicht [g] Weight [g]	Profil Profile	Teil-Nr. Part #
blank <i>Plain</i>		339.0		093W901
	8	341.0		093W901N08
	10	358.0		093W901N10
alufarbig <i>Alu color</i>	10	360.0		093W901N10S06
Nutfixierung <i>Centering pieces</i>	Nut 8 auf Nut 10 <i>Slot 8 to slot 10</i>	1.0		093W02
Abdeckkappe <i>Cover cap</i>		60.0		093WA901
blank, inkl. Montageset <i>Plain, with assembly set</i>	10	527.1	B	093W901N10S02
alufarbig, inkl. Montageset <i>Alu color, with assembly set</i>	10	532.0	B	093W901N10S07

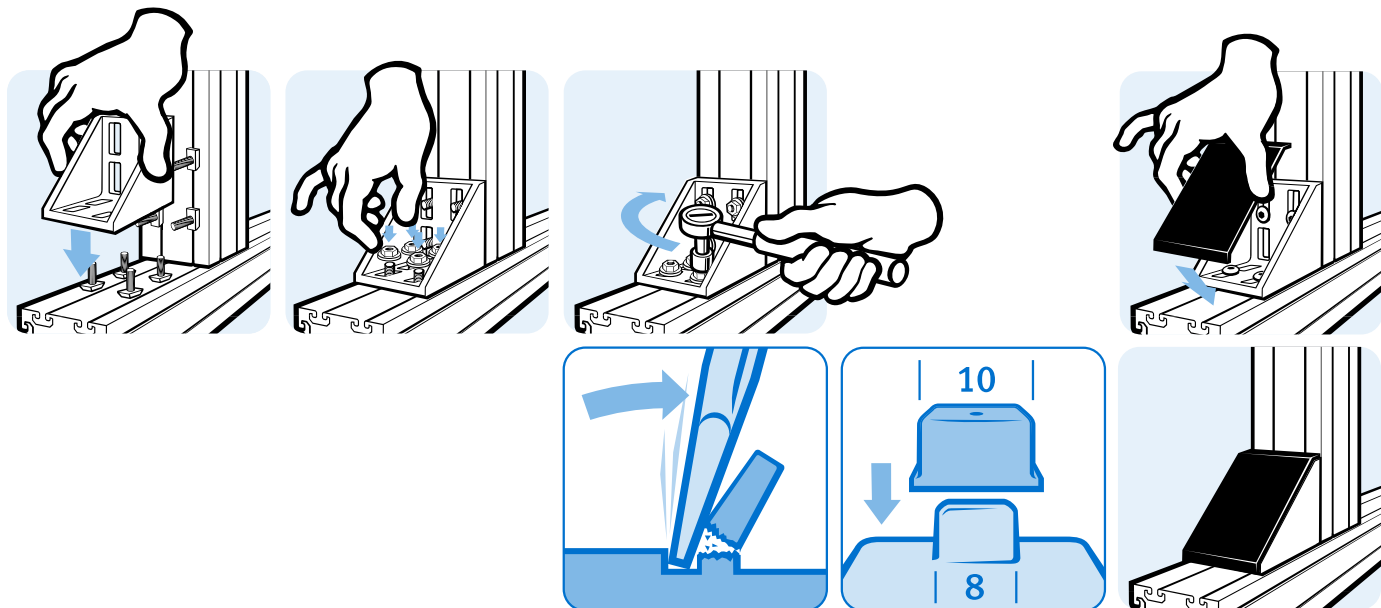



VERSTEIFUNGSWINKEL 80 × 180

SUPPORT BRACKET 80 × 180

Ausführung	Aluminiumdruckguss, ab Profil 80	Model	Aluminum die-cast, profile 80 and up
Beschreibung	zur rechtwinkligen Verbindung von zwei Aluminiumprofilen oder zur festen Verbindung von Aluminiumprofilen mit dem Boden	Description	To connect two aluminum profiles at right angles or to securely fix aluminum profiles to the floor
Material	Aluminiumdruckguss	Material	Aluminum die-cast
Liefereinheit	10 Stück	Pack Quantity	10 pieces
Extras	weitere Oberflächen, weitere Farben auf Anfrage	Specials	Other surfaces, other colors on request

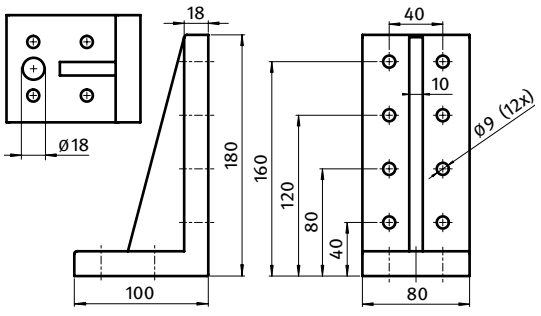

Verstärkungswinkel 80 × 180 Support bracket 80 × 180		Gewicht [g] Weight [g]	Teil-Nr. Part #
blank Plain		681.0	093W805
alufarbig Aluminum color		681.0	093W805S01

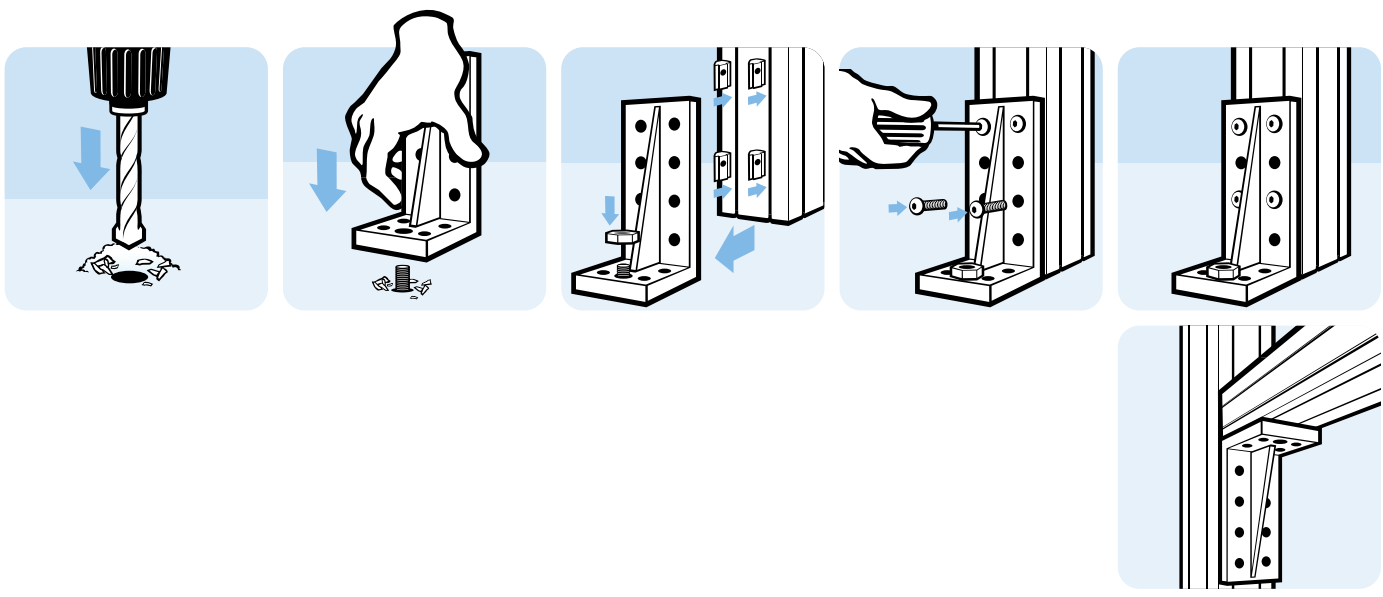

4



WINKEL 20

CONNECTION ANGLE 20

Ausführung	Zinkdruckguss	Model	Zinc die-cast
Beschreibung	zur rechtwinkligen Verbindung von Profilen und Flächenelementen; die offene Seite des Winkels kann durch die Abdeckkappe verschlossen werden	Description	To connect two aluminum profiles or panels at right angles; the connection angle can be closed with the cover cap
Material	Winkel: Zinkdruckguss Abdeckkappe: Kunststoff PA, glasfaserverstärkt Montageset: Stahl	Material	Angle: Zinc die-cast Cover cap: Plastic PA, glass fiber reinforced Assembly set: Steel
Farbe	Abdeckkappe: schwarz	Color	Cover cap: Black
Montageset	1 Abdeckkappe - Kunststoff PA - schwarz, 2 Nutensteine - Nut 5 - M5, 2 Schrauben DIN 6912 - M5 × 8	Assembly Set	1 cover cap - plastic PA - black, 2 T-slot nuts - slot 5 - M5, 2 screws DIN 6912 - M5 × 8
Liefereinheit	10 Stück	Pack Quantity	10 pieces
Extras	weitere Oberflächen, weitere Farben auf Anfrage	Specials	Other surfaces, other colors on request

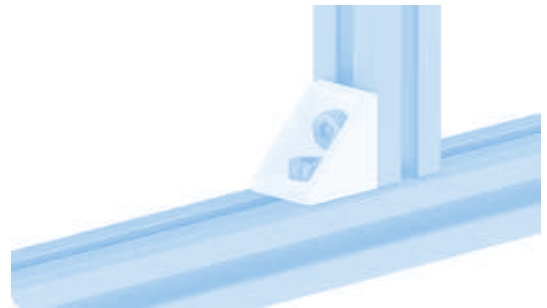
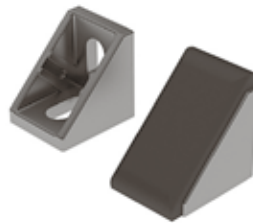
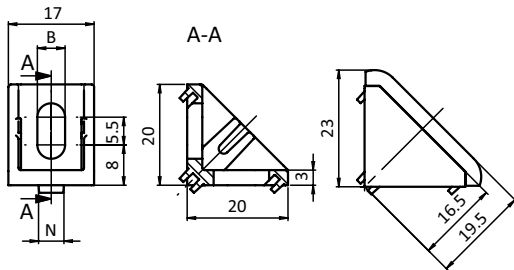

Winkel 20 Connection Angle 20	B [mm]	N	Gewicht [g] Weight [g]	Profil Profile	Teil-Nr. Part #
blank <i>Plain</i>	6.2		13.0		093W201R
	5.5	5	13.2		093W201N05R
	6.2	6	14.0		093W201N06R
alufarbig <i>Alu color</i>	6.2		13.2		093W201
	5.5	5	13.6		093W201N05
	6.2	6	14.2		093W201N06
Abdeckkappe <i>Cover cap</i>			1.6		093WA201
alufarbig inkl. Montageset <i>Alu color with assembly set</i>	5.5	5	24.7	I	093W201N05S01

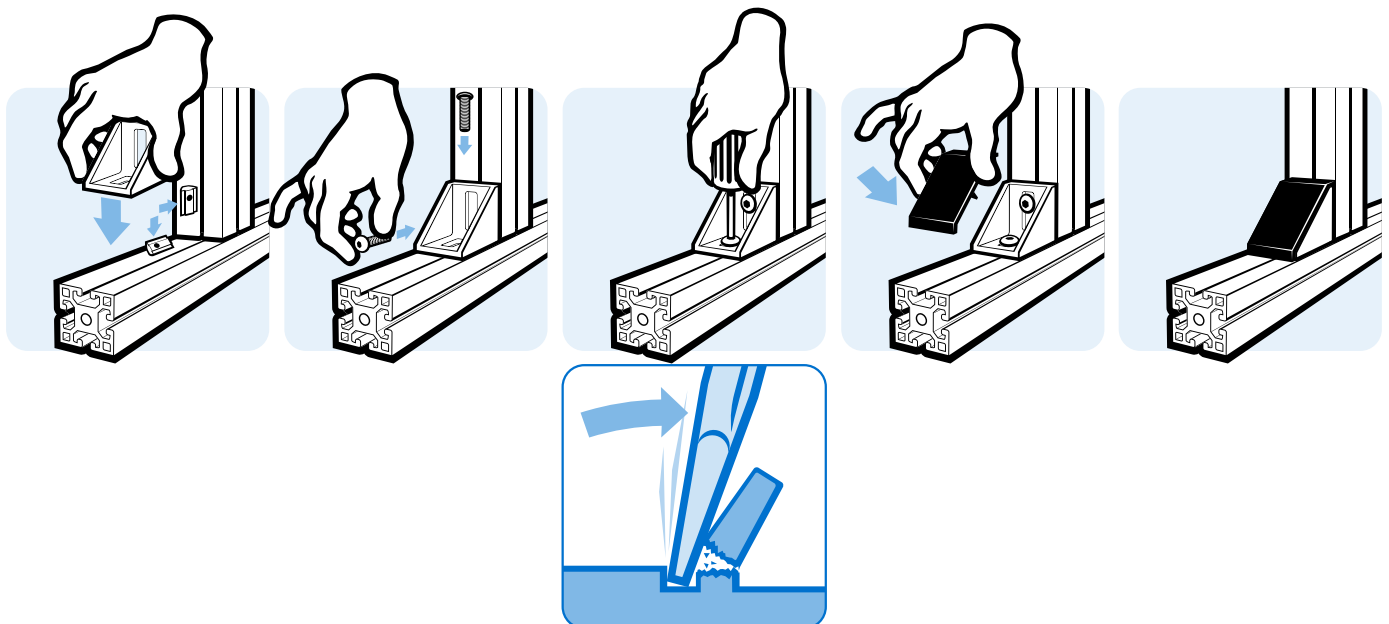



WINKEL 20 × 28

CONNECTION ANGLE 20 × 28

Ausführung	Zinkdruckguss	Model	Zinc die-cast
Beschreibung	zur rechtwinkligen Verbindung von zwei Profilen und Flächenelementen	Description	To connect two profiles and panels at right angles
Material	Winkel: Zinkdruckguss Montageset: Stahl Nutfixierung: Kunststoff PA, glasfaserverstärkt	Material	Angle: Zinc die-cast Assembly set: Steel Centering piece: Plastic PA, glass fiber reinforced
Farbe	Nutfixierung: natur	Color	Centering piece: Natural
Montageset	2 Hammermuttern - Nut 8 - M6, 2 Schrauben DIN 7984 - M6 × 12	Assembly Set	2 hammer nuts - slot 8 - M6, 2 screws DIN 7984 - M6 × 12
Liefereinheit	10 Stück	Pack Quantity	10 pieces
Extras	weitere Oberflächen, weitere Farben auf Anfrage	Specials	Other surfaces, other colors on request

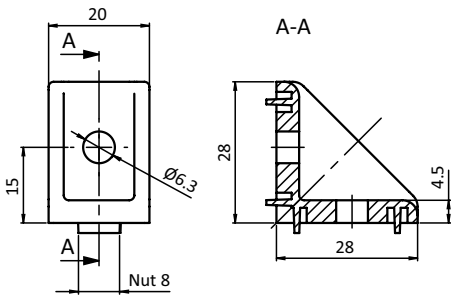

Winkel 20 × 28
Connection Angle 20 × 28

	N	Gewicht [g] Weight [g]	Profil Profile	Teil-Nr. Part #
blank Plain	8	34.0		093W206N08R
Nutfixierung Centering pieces Nut 8 auf Nut 10 Slot 8 to slot 10		1.0		093W03
inkl. Montageset With assembly set	8	50.0	B	093W206N08RS02

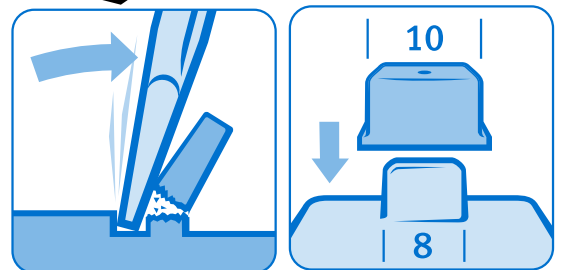
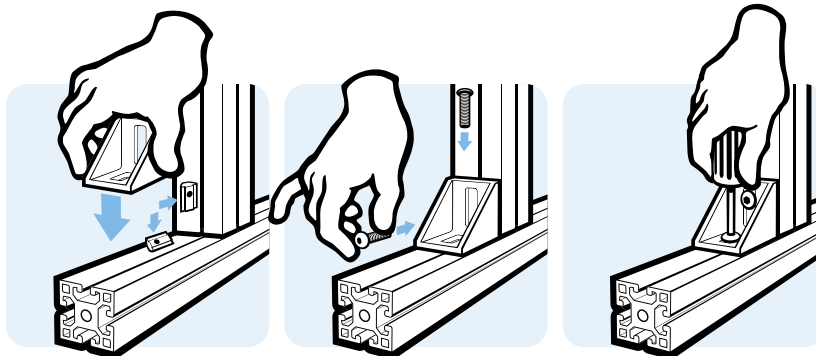



WINKEL 30

CONNECTION ANGLE 30

Ausführung	Zinkdruckguss	Model	Zinc die-cast
Beschreibung	zur rechtwinkligen Verbindung von Profilen und Flächenelementen; die offene Seite des Winkels kann durch die Abdeckkappe verschlossen werden	Description	To connect two aluminum profiles or panels at right angles; the connection angle can be closed with the cover cap
Material	Winkel: Zinkdruckguss Abdeckkappe: Kunststoff PA, glasfaserverstärkt Montageset: Stahl	Material	Angle: Zinc die-cast Cover cap: Plastic PA, glass fiber reinforced Assembly set: Steel
Farbe	Abdeckkappe: schwarz	Color	Cover cap: Black
Montageset	1 Abdeckkappe - Kunststoff PA - schwarz, 2 Nutensteine - Nut 6 - M6, 2 Schrauben ISO 7380 - M6 × 12	Assembly Set	1 Cover cap - Plastic PA - black, 2 T-slot nuts - slot 6 - M6, 2 Screws ISO 7380 - M6 × 12
Liefereinheit	10 Stück	Pack Quantity	10 pieces
Extras	weitere Oberflächen, weitere Farben auf Anfrage	Specials	Other surfaces, other colors on request

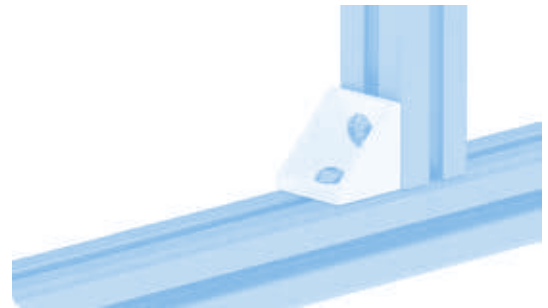
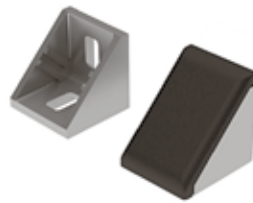
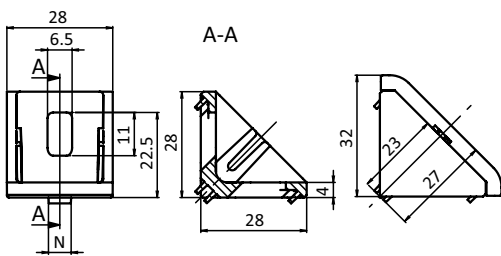

Winkel 30 Connection Angle 30	N	Gewicht [g] Weight [g]	Profil Profile	Teil-Nr. Part #
blank Plain		39.0		093W301R
	6	39.4		093W301N06R
	8	39.6		093W301N08R
alufarbig Alu color		39.4		093W301
	6	40.0		093W301N06
	8	40.5		093W301N08
Abdeckkappe Cover cap		5.5		093WA301
alufarbig inkl. Montageset Alu color with assembly set	6	68.0	I	093W301N06S01

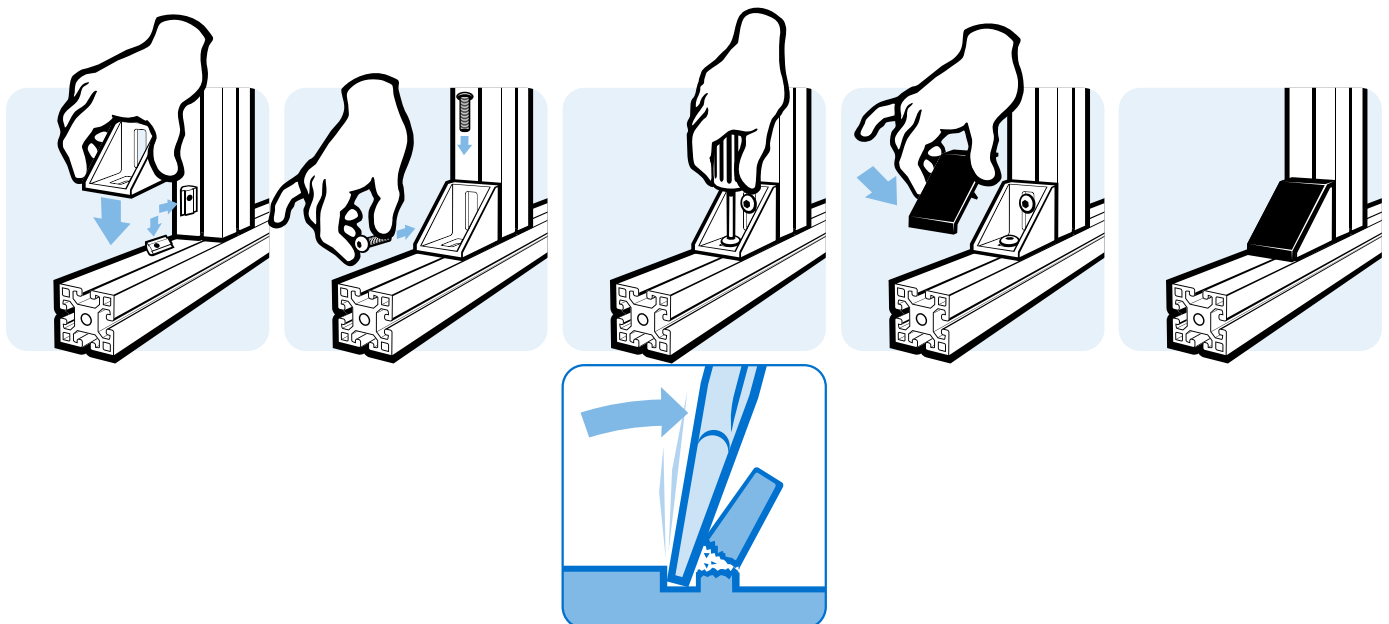



WINKEL 40 FLACH

CONNECTION ANGLE 40 FLAT

Ausführung	Zinkdruckguss	Model	Zinc die-cast
Beschreibung	zur rechtwinkligen Verbindung von Profilen und Flächenelementen; die offene Seite des Winkels kann durch die Abdeckkappe verschlossen werden	Description	To connect two aluminum profiles or panels at right angles; the connection angle can be closed with the cover cap
Material	Winkel: Zinkdruckguss Abdeckkappe: Kunststoff PA, glasfaserverstärkt Montageset: Stahl	Material	Angle: Zinc die-cast Cover cap: Plastic PA, glass fiber reinforced Assembly set: Steel
Farbe	Abdeckkappe: schwarz, grau	Color	Cover cap: Black, gray
Montageset	1 Abdeckkappe - Kunststoff PA - schwarz, 2 Nutensteine - Nut 8 - M8, 2 Schrauben ISO 7380 - M8 × 16	Assembly Set	1 Cover cap - Plastic PA - black, 2 T-slot nuts - slot 8 - M8, 2 Screws ISO 7380 - M8 × 16
Liefereinheit	10 Stück	Pack Quantity	10 pieces
Extras	weitere Oberflächen, weitere Farben auf Anfrage	Specials	Other surfaces, other colors on request

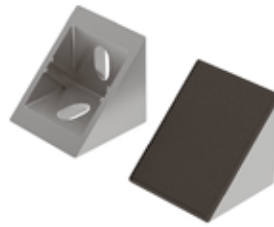
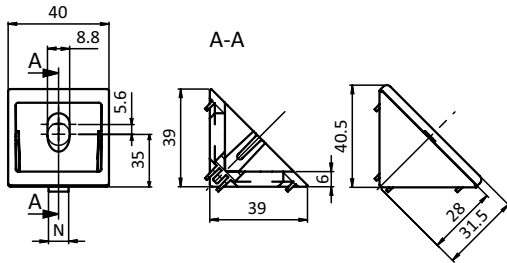

Winkel 40 flach Connection Angle 40 Flat	N	Gewicht [g] Weight [g]	Profil Profile	Teil-Nr. Part #
blank <i>Plain</i>		84.6		093W401R
	8	84.0		093W401N08R
	10	87.4		093W401N10R
alufarbig <i>Alu color</i>		86.8		093W401
	8	88.0		093W401N08
	10	90.0		093W401N10
Abdeckkappe schwarz <i>Cover cap black</i>		8.0		093WA401
Abdeckkappe grau ≈ RAL 7042 <i>Cover cap gray</i>		8.0		093WA401S01
alufarbig inkl. Montageset <i>Alu color with assembly set</i>	8	135.5	I	093W401N08S03

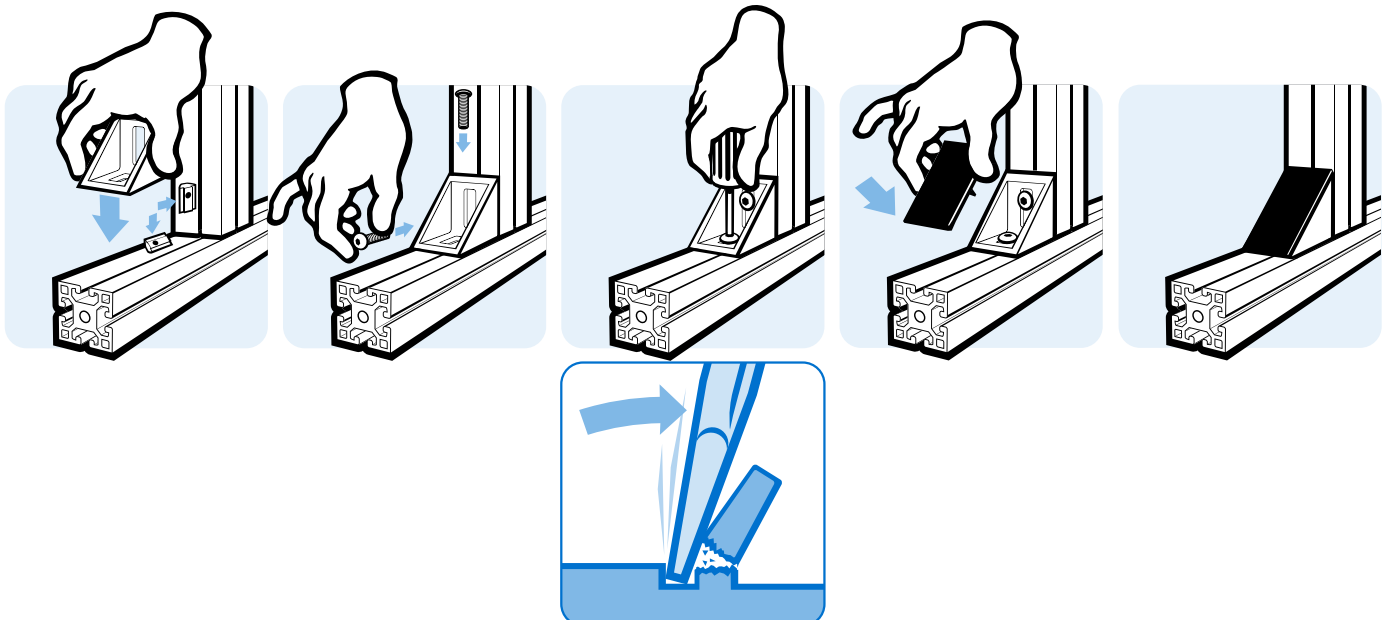



WINKEL 40

CONNECTION ANGLE 40

Ausführung	Zinkdruckguss	Model	Zinc die-cast
Beschreibung	zur rechtwinkligen Verbindung von Profilen und Flächenelementen; die offene Seite des Winkels kann durch die Abdeckkappe verschlossen werden	Description	To connect two aluminum profiles or panels at right angles; the connection angle can be closed with the cover cap
Material	Winkel: Zinkdruckguss Abdeckkappe: Kunststoff PA, glasfaserverstärkt Montageset: Stahl	Material	Angle: Zinc die-cast Cover cap: Plastic PA, glass fiber reinforced Assembly set: Steel
Farbe	Abdeckkappe: schwarz	Color	Cover cap: Black
Montageset	1 Abdeckkappe - Kunststoff PA - schwarz, 2 Nutensteine - Nut 8 - M8, 2 Schrauben ISO 7380 - M8 × 16	Assembly Set	1 Cover cap - Plastic PA - black, 2 T-slot nuts - slot 8 - M8, 2 Screws ISO 7380 - M8 × 16
Liefereinheit	10 Stück	Pack Quantity	10 pieces
Extras	weitere Oberflächen, weitere Farben auf Anfrage	Specials	Other surfaces, other colors on request

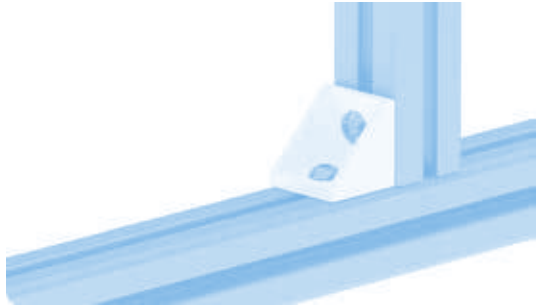
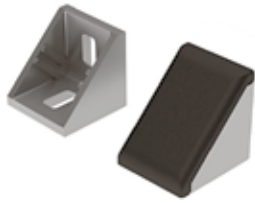
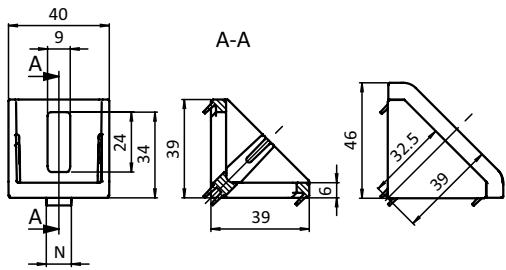

Winkel 40 Connection Angle 40	N	Gewicht [g] Weight [g]	Profil Profile	Teil-Nr. Part #
blank Plain		95.9		093W402R
	8	98.0		093W402N08R
	10	99.0		093W402N10R
alufarbig Alu color		97.8		093W402
	8	100.0		093W402N08
	10	102.5		093W402N10
Abdeckkappe Cover cap		11.4		093WA402
alufarbig inkl. Montageset Alu color with assembly set	8	146.5	I	093W402N08S02

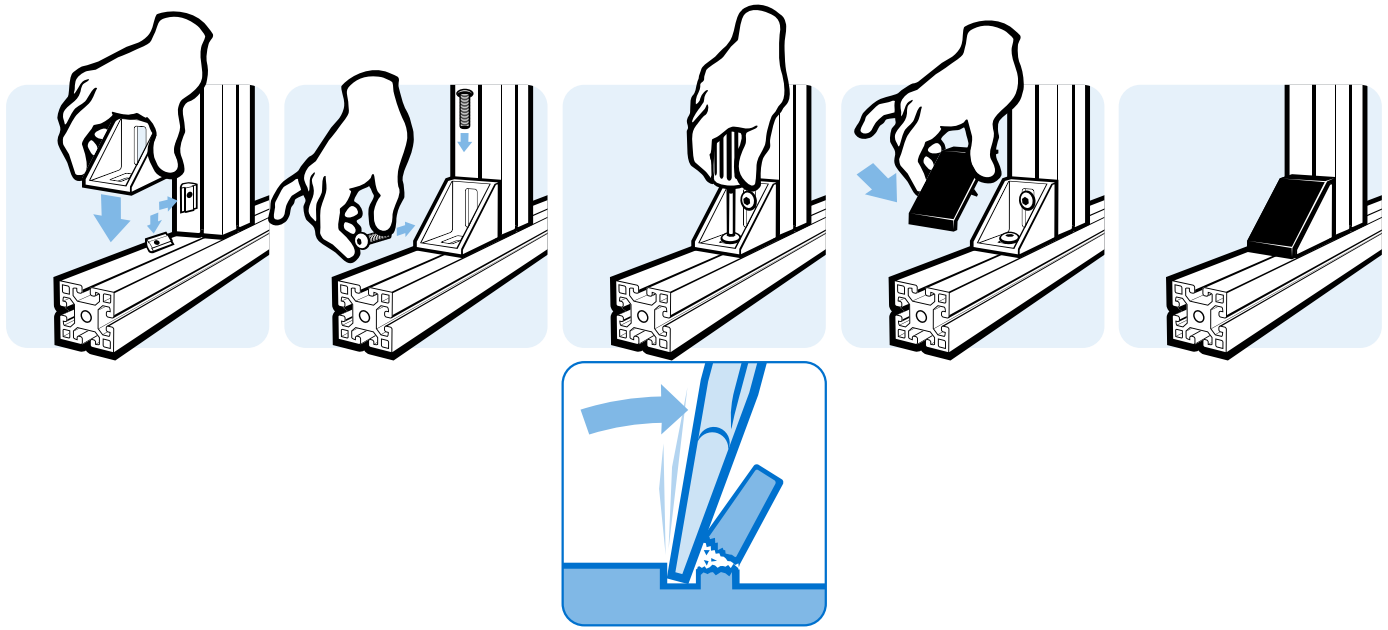



VERBINDUNGSWINKEL V 40 (SET)

CONNECTION ANGLE V 40 (SET)

<p>Ausführung Zinkdruckguss, Nut 8</p> <p>Beschreibung zur rechtwinkligen Verbindung von Profilen und Flächenelementen; besonders geeignet für horizontale Profile zwischen Ständerprofilen oder zur Befestigung anderer Bauteile an Profilen; mit Verdrehsicherung Nut 8 auf einer Rückseite</p> <p>Material Verbindungswinkel: Zinkdruckguss Schrauben und Nutensteine: Stahl</p> <p>Set 1 Verbindungswinkel V 40 - Nut 8, 2 Schrauben DIN 7991 - M8 × 18, 2 Nutensteine - Nut 8 - M8</p> <p>Liefereinheit 10 Stück</p> <p>Extras weitere Oberflächen, weitere Farben auf Anfrage</p>	<p>Model Zinc die-cast, slot 8</p> <p>Description To connect two aluminum profiles or panels at right angles; particularly suitable for fixing horizontal profiles between upright profiles or for attaching other components to profiles; with turn-lock slot 8 on one of the rear sides</p> <p>Material Connection angle: Zinc die-cast Screws and T-slot nuts: Steel</p> <p>Set 1 connection angle V40 - slot 8, 2 screws DIN 7991 - M8 × 18, 2 T-slot nuts - slot 8 - M8</p> <p>Pack Quantity 10 pieces</p> <p>Specials Other surfaces, other colors on request</p>
---	---

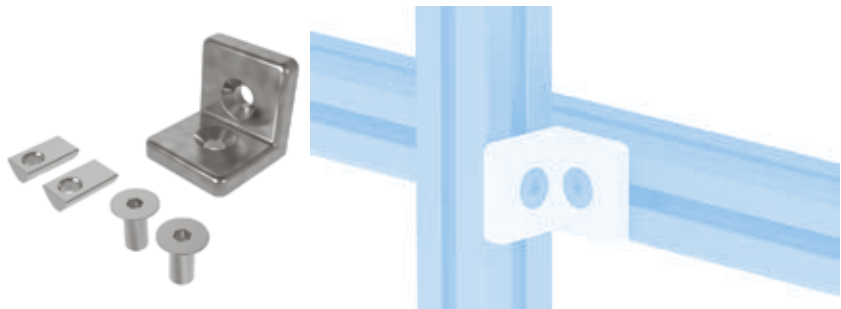
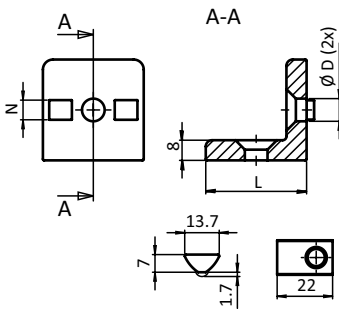

Verbindungswinkel V 40 (Set) Connection Angle V 40 (Set)	D	N	L × B × H [mm]	Gewicht [g] Weight [g]	Profil Profile	Teil-Nr. Part #
	9.0	8	40 × 40 × 40	164.7	I	093WI40N08S01



WINKEL 40/80 FLACH

CONNECTION ANGLE 40/80 FLAT

Ausführung	Zinkdruckguss	Model	Zinc die-cast
Beschreibung	zur rechtwinkligen Verbindung von Profilen und Flächenelementen; die offene Seite des Winkels kann durch die Abdeckkappe verschlossen werden	Description	To connect two aluminum profiles or panels at right angles; the connection angle can be closed with the cover cap
Material	Winkel: Zinkdruckguss Abdeckkappe: Kunststoff PA, glasfaserverstärkt Montageset: Stahl	Material	Angle: Zinc die-cast Cover cap: Plastic PA, glass fiber reinforced Assembly set: Steel
Farbe	Abdeckkappe: schwarz	Color	Cover cap: Black
Montageset	1 Abdeckkappe - Kunststoff PA - schwarz, 4 Nutensteine - Nut 8 - M8, 4 Schrauben ISO 7380 - M8 x 16	Assembly Set	1 Cover cap - Plastic PA - black, 4 T-slot nuts - slot 8 - M8, 4 Screws ISO 7380 - M8 x 16
Liefereinheit	10 Stück	Pack Quantity	10 pieces
Extras	weitere Oberflächen, weitere Farben auf Anfrage	Specials	Other surfaces, other colors on request

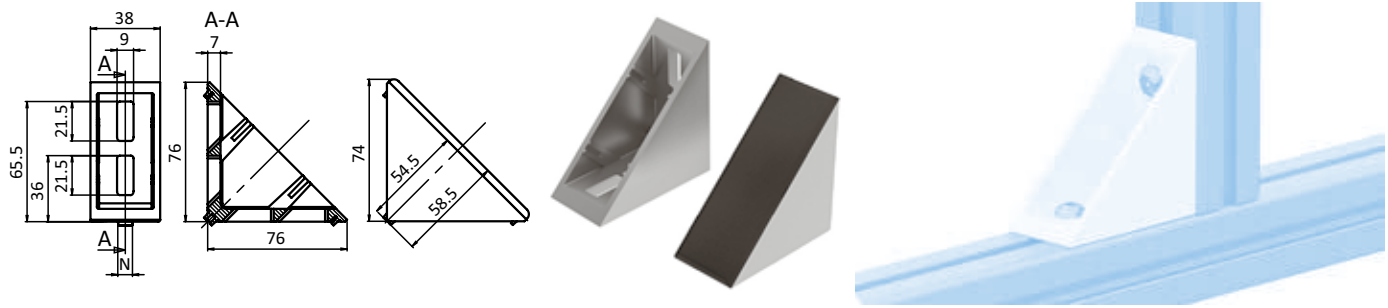

Winkel 40/80 flach Connection Angle 40/80 Flat	N	Gewicht [g] Weight [g]	Profil Profile	Teil-Nr. Part #
blank <i>Plain</i>		267.0		093W802R
	8	269.0		093W802N08R
	10	269.5		093W802N10R
alufarbig <i>Alu color</i>		267.5		093W802
	8	270.0		093W802N08
	10	271.0		093W802N10
Abdeckkappe <i>Cover cap</i>		17.2		093WA802
inkl. Montageset <i>With assembly set</i>	8	361.0	I	093W802N08S02



WINKEL 60

CONNECTION ANGLE 60

Ausführung	Zinkdruckguss	Model	Zinc die-cast
Beschreibung	zur rechtwinkligen Verbindung von Profilen und Flächenelementen; die offene Seite des Winkels kann durch die Abdeckkappe verschlossen werden	Description	To connect two aluminum profiles or panels at right angles; the connection angle can be closed with the cover cap
Material	Winkel: Zinkdruckguss Abdeckkappe: Kunststoff PA, glasfaserverstärkt	Material	Angle: Zinc die-cast Cover cap: Plastic PA, glass fiber reinforced
Farbe	Abdeckkappe: schwarz	Color	Cover cap: Black
Liefereinheit	10 Stück	Pack Quantity	10 pieces
Extras	weitere Oberflächen, weitere Farben auf Anfrage	Specials	Other surfaces, other colors on request

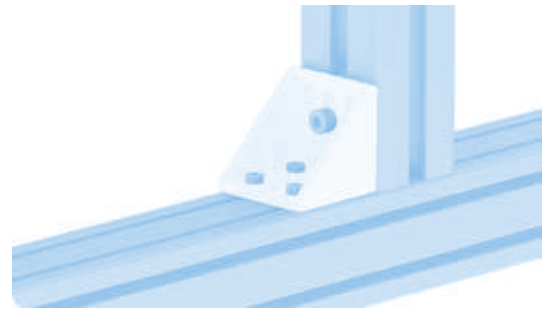
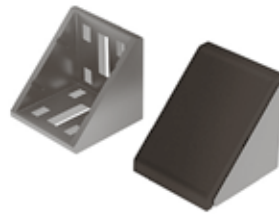
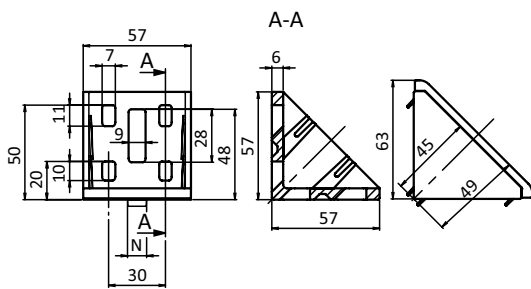

Winkel 60 Connection Angle 60	N	Gewicht [g] Weight [g]	Teil-Nr. Part #
blank Plain		222.0	093W601R
	8	225.0	093W601N08R
	10	227.0	093W601N10R
alufarbig Alu color		224.0	093W601
	8	228.0	093W601N08
	10	230.0	093W601N10
Abdeckkappe Cover cap		24.6	093WA601

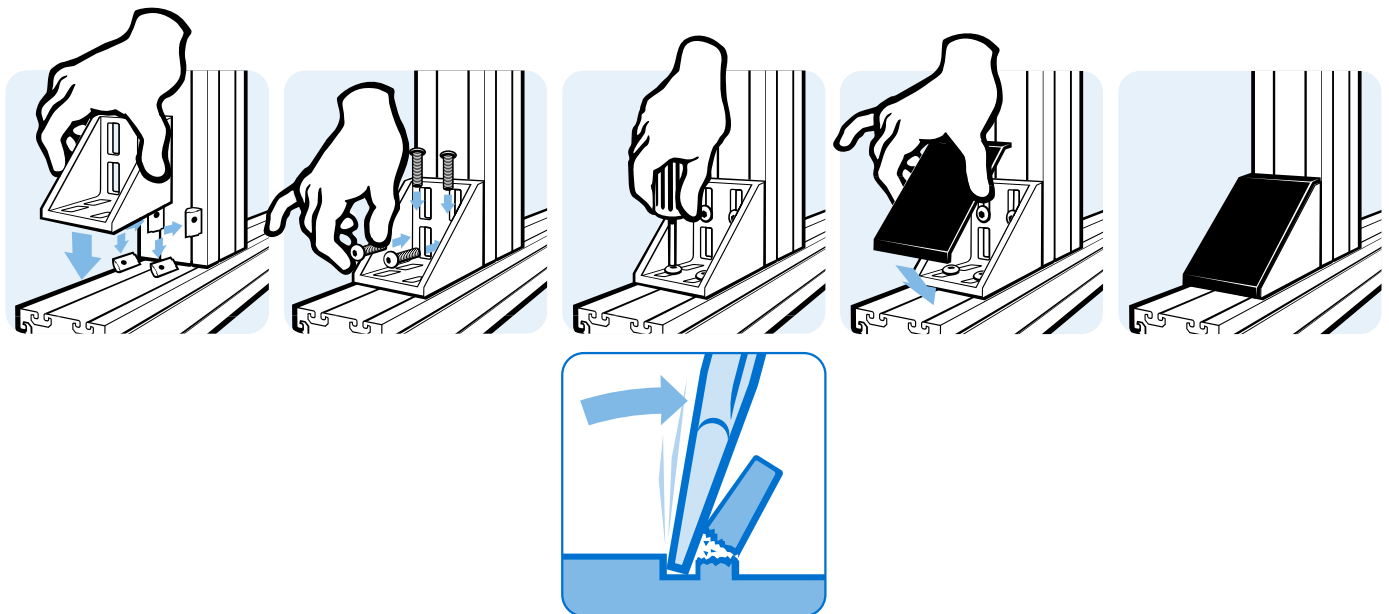



WINKEL 80 FLACH

CONNECTION ANGLE 80 FLAT

Ausführung	Zinkdruckguss	Model	Zinc die-cast
Beschreibung	zur rechtwinkligen Verbindung von Profilen und Flächenelementen; die offene Seite des Winkels kann durch die Abdeckkappe verschlossen werden	Description	To connect two aluminum profiles or panels at right angles; the connection angle can be closed with the cover cap
Material	Winkel: Zinkdruckguss Abdeckkappe: Kunststoff PA, glasfaserverstärkt	Material	Angle: Zinc die-cast Cover cap: Plastic PA, glass fiber reinforced
Farbe	Abdeckkappe: schwarz	Color	Cover cap: Black
Oberfläche	Winkel: blank / alufarbig pulverbeschichtet	Surface	Angle: Plain / alu color powder coated
Liefereinheit	10 Stück	Pack Quantity	10 pieces
Extras	weitere Oberflächen, weitere Farben auf Anfrage	Specials	Other surfaces, other colors on request

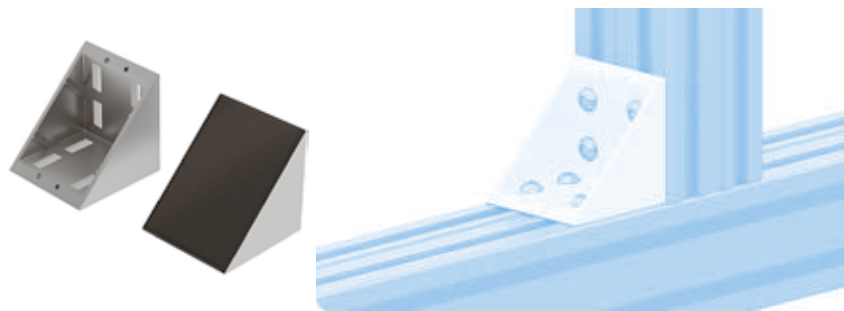
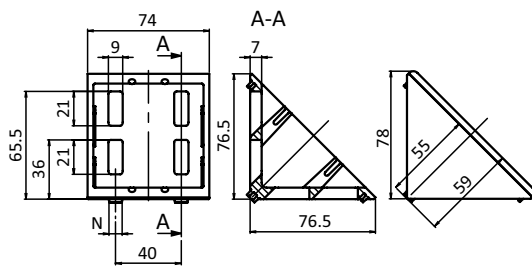

Winkel 80 flach Connection Angle 80 Flat	N	Gewicht [g] Weight [g]	Teil-Nr. Part #
blank Plain		403.0	093W803R
	8	407.0	093W803N08R
	10	412.5	093W803N10R
alufarbig Alu color		405.0	093W803
	8	410.0	093W803N08
	10	415.0	093W803N10
Abdeckkappe Cover cap		39.8	093WA803

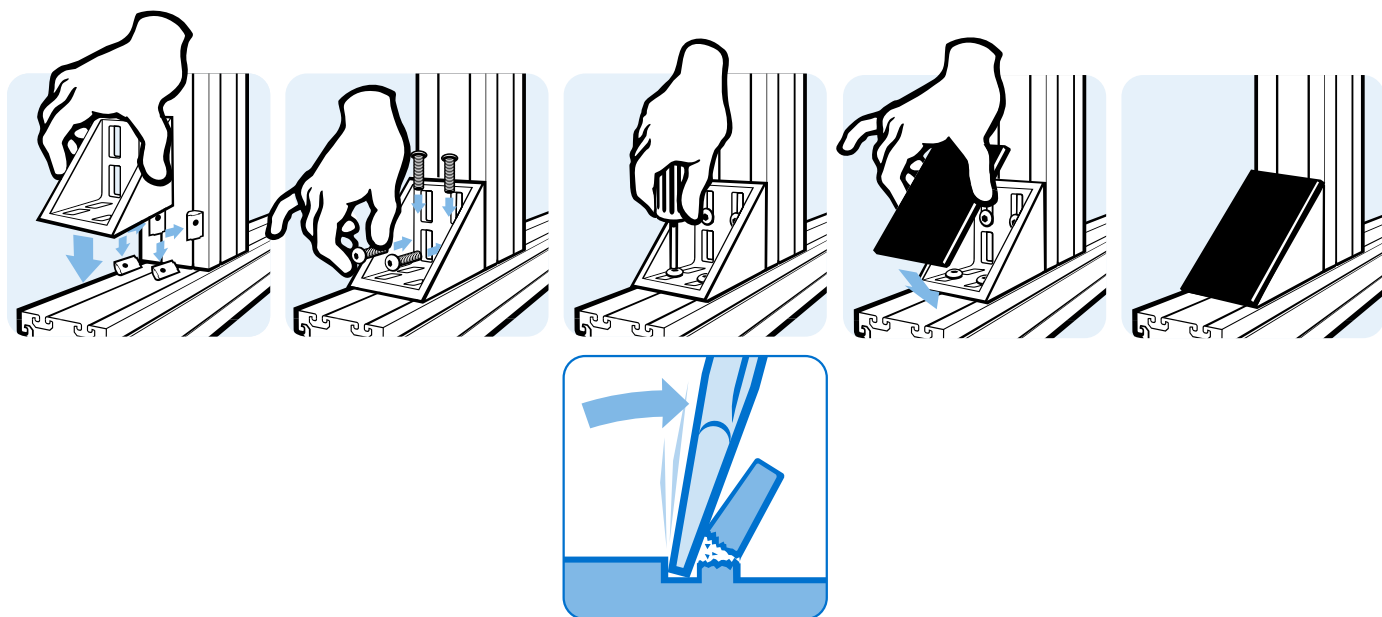



WINKEL 80/160

CONNECTION ANGLE 80/160

Ausführung	Grauguss	Model	Gray cast iron
Beschreibung	zur rechtwinkligen Verbindung von zwei Aluminiumprofilen oder zur festen Verbindung von Aluminiumprofilen mit dem Boden	Description	To connect two aluminum profiles or panels at right angles or to securely fix aluminum profile to the floor
Material	Grauguss	Material	Gray cast iron
Liefereinheit	10 Stück	Pack Quantity	10 pieces
Extras	weitere Oberflächen, weitere Farben auf Anfrage	Specials	Other surfaces, other colors on request
Hinweis	passender Befestigungsnutenstein für Winkel 80/160 siehe Seite 359	Tip	Compatible fixation T-slot nut for connection angle 80/160 see page 359

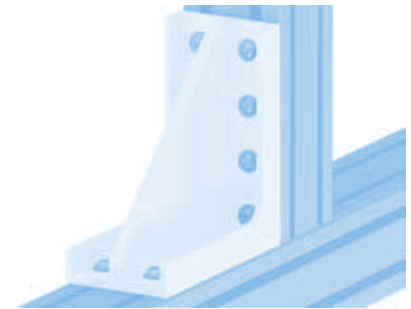
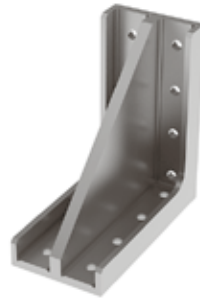
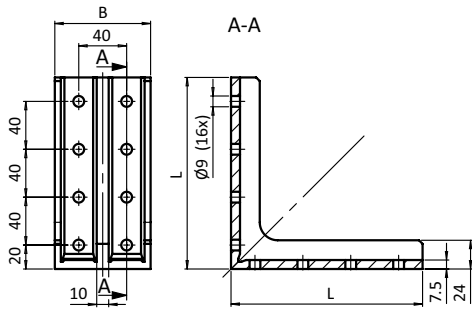

Winkel 80/160 Connection Angle 80/160	B [mm]	L [mm]	N	Gewicht [g] Weight [g]	Profil Profile	Teil-Nr. Part #
	80	160	8	2604.0	I	093W807



BEFESTIGUNGSNUTENSTEIN (SET) FÜR WINKEL 80/160 *ROLL-IN T-SLOT NUT FOR CONNECTION ANGLE 80/160*

Ausführung	Nut 8, mit Federkugel, Stahl	Model	Slot 8, with spring ball, steel
Beschreibung	einschwenkbarer Nutenstein mit Federkugel	Description	Roll-in T-slot nut with spring ball
Material	Nutenstein, Schrauben und Scheiben: Stahl, verzinkt Kugel: Edelstahl	Material	T-slot nut, screws and shims: Zinc plated steel Ball: Stainless steel
Set	1 Befestigungsnutenstein mit Federkugel, Nut 8 ohne Steg, 4x M8, 4 Schrauben ISO 7380 - M8 x 20, 4 Scheiben DIN 125 - 8,4	Set	1 T-slot nut with spring ball, Nut 8 without step, 4x M8, 4 screws ISO 7380 - M8 x 20, 4 shims DIN 125 - 8,4
Liefereinheit	10 Stück	Pack Quantity	10 pieces
Extras	🔌 elektrostatisch entladend auf Anfrage	Specials	🔌 electrostatically discharging available on request

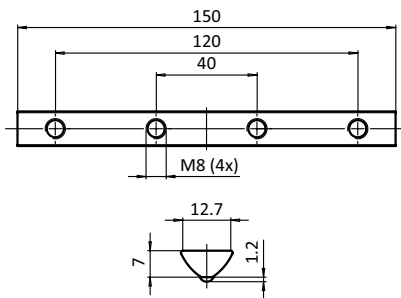

Nutenstein <i>T-slot Nut</i>	Größe <i>Size</i>	Gewicht [g] <i>Weight [g]</i>	Profil <i>Profile</i>	Teil-Nr. <i>Part #</i>
	M8	122.3	I	096000S83

4



STAHLWINKEL 30/45

STEEL CONNECTION ANGLE 30/45

Ausführung	Stahl, ab Profil 30	Model	Steel, profile 30 and up
Beschreibung	zur rechtwinkligen Verbindung von zwei Aluminiumprofilen	Description	To connect two aluminum profiles at right angles
Material	Stahl	Material	Steel
Liefereinheit	10 Stück	Pack Quantity	10 pieces

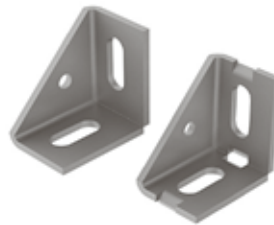
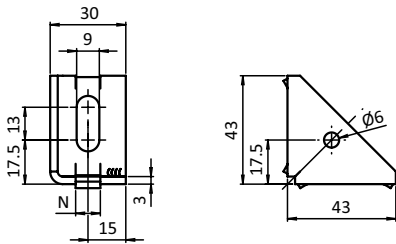

Stahlwinkel 30/45
Steel Connection Angle 30/45

N

Gewicht [g]
Weight [g]

Teil-Nr.
Part #

	N	Gewicht [g] Weight [g]	Teil-Nr. Part #
		41.0	093WV431V
	10	61.4	093WV432V



STAHLWINKEL 30/80

STEEL CONNECTION ANGLE 30/80

Ausführung	Stahl, ab Profil 30	Model	Steel, profile 30 and up
Beschreibung	zur rechtwinkligen Verbindung von zwei Aluminiumprofilen	Description	To connect two aluminum profiles at right angles
Material	Stahl	Material	Steel
Oberfläche	verzinkt	Surface	Zinc plated
Liefereinheit	10 Stück	Pack Quantity	10 pieces

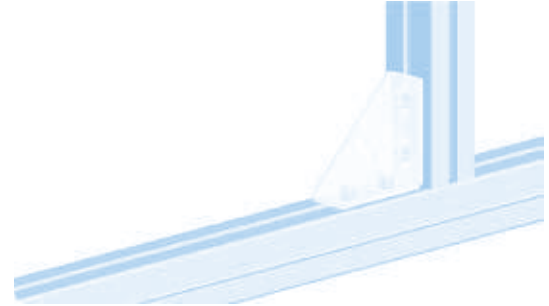
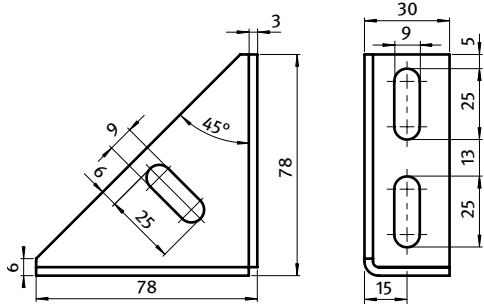

Stahlwinkel 30/80
 Steel Connection Angle 30/80

Gewicht [g]
 Weight [g]

Teil-Nr.
 Part #

139.0

093WV781V



STAHLWINKEL 30/100 - 1-LOCH

STEEL CONNECTION ANGLE 30/100 - 1-HOLE

Ausführung	Stahl, ab Profil 30	Model	Steel, profile 30 and up
Beschreibung	zur rechtwinkligen Verbindung von zwei Aluminiumprofilen	Description	To connect two aluminum profiles at right angles
Material	Stahl	Material	Steel
Liefereinheit	10 Stück	Pack Quantity	10 pieces

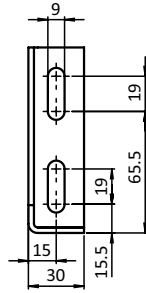
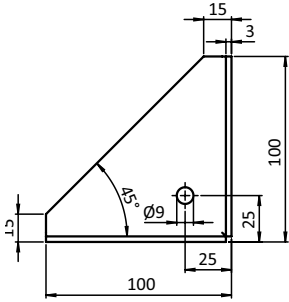

Stahlwinkel 30/100
Steel Connection Angle 30/100

Gewicht [g]
Weight [g]

Teil-Nr.
Part #

232.0

093WV1003V



STAHLWINKEL 45/100

STEEL CONNECTION ANGLE 45/100

Ausführung	Stahl, ab Profil 45	Model	Steel, profile 45 and up
Beschreibung	zur rechtwinkligen Verbindung von zwei Aluminiumprofilen	Description	To connect two aluminum profiles at right angles
Material	Stahl	Material	Steel
Liefereinheit	10 Stück	Pack Quantity	10 pieces

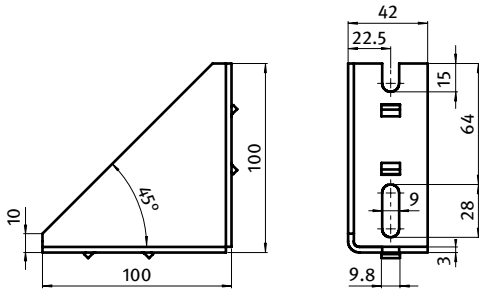

Stahlwinkel 45/100
 Steel Connection Angle 45/100

N

Gewicht [g]
 Weight [g]

Teil-Nr.
 Part #

278.9

093WV1002V

10

277.2

093WV1001V



STAHLWINKEL 20

STEEL CONNECTION ANGLE 20

Ausführung	Stahl, ab Profil 20	Model	Steel, profile 20 and up
Beschreibung	zur rechtwinkligen Verbindung von zwei Aluminiumprofilen	Description	To connect two aluminum profiles at right angles
Material	Stahl	Material	Steel
Liefereinheit	10 Stück	Pack Quantity	10 pieces
Extras	weitere Oberflächen auf Anfrage	Specials	Other surfaces on request

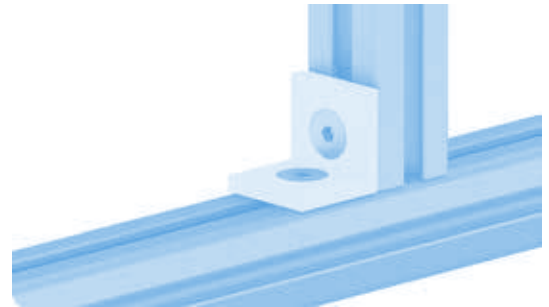
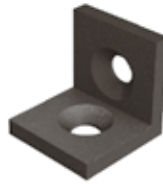
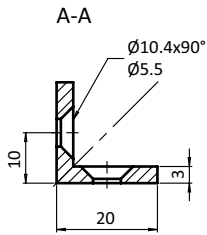
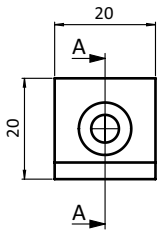

Stahlwinkel 20
 Steel Connection Angle 20

Gewicht [g]
 Weight [g]

Teil-Nr.
 Part #

schwarz pulverbeschichtet *Black powder coated*

15.3

093WU201S

4



STAHLWINKEL 30

STEEL CONNECTION ANGLE 30

Ausführung	Stahl, ab Profil 30	Model	Steel, profile 30 and up
Beschreibung	zur rechtwinkligen Verbindung von zwei Aluminiumprofilen	Description	To connect two aluminum profiles at right angles
Material	Stahl	Material	Steel
Liefereinheit	10 Stück	Pack Quantity	10 pieces
Extras	weitere Oberflächen auf Anfrage	Specials	Other surfaces on request

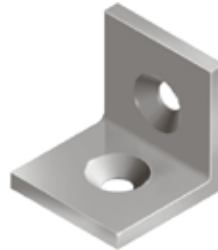
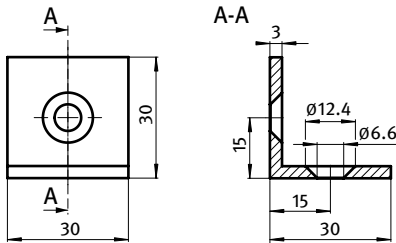

Stahlwinkel 30
Steel Connection Angle 30

Gewicht [g]
Weight [g]

Teil-Nr.
Part #

blau verzinkt <i>Blue zinc plated</i>	37.5	093WU302V
schwarz pulverbeschichtet <i>Black powder coated</i>	37.5	093WU302S





STAHLWINKEL 40

STEEL CONNECTION ANGLE 40

Ausführung	Stahl, ab Profil 40	Model	Steel, profile 40 and up
Beschreibung	zur rechtwinkligen Verbindung von zwei Aluminiumprofilen	Description	To connect two aluminum profiles at right angles
Material	Stahl	Material	Steel
Liefereinheit	10 Stück	Pack Quantity	10 pieces
Extras	weitere Oberflächen auf Anfrage	Specials	Other surfaces on request

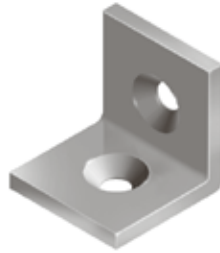
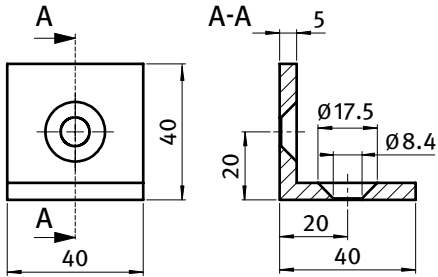

Stahlwinkel 40
Steel Connection Angle 40

Gewicht [g]
Weight [g]

Teil-Nr.
Part #

blau verzinkt <i>Blue zinc plated</i>	102.0	093WU401VS01
schwarz pulverbeschichtet <i>Black powder coated</i>	102.0	093WU401S



STAHLWINKEL 40 LANGLOCH

STEEL CONNECTION ANGLE 40 EH

Ausführung	Stahl, ab Profil 40	Model	Steel, profile 40 and up
Beschreibung	zur rechtwinkligen Verbindung von zwei Aluminiumprofilen	Description	To connect two aluminum profiles at right angles
Material	Stahl	Material	Steel
Oberfläche	verzinkt	Surface	Zinc plated
Liefereinheit	10 Stück	Pack Quantity	10 pieces
Extras	weitere Oberflächen auf Anfrage	Specials	Other surfaces on request

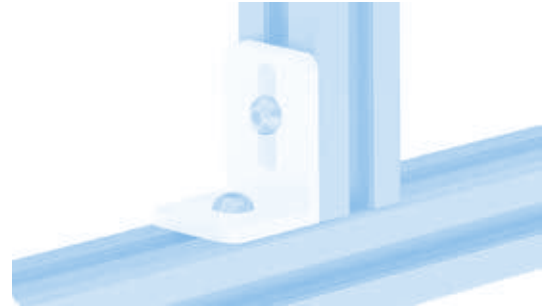
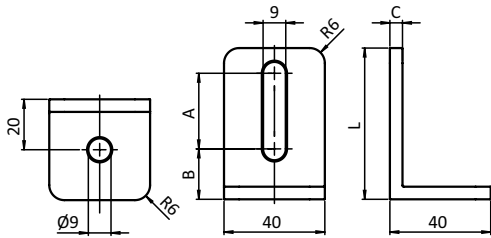

A [mm]	B [mm]	C [mm]	L [mm]	Gewicht [g] Weight [g]	Teil-Nr. Part #
30.0	20.0	5.0	60.0	130.5	093WU4060V
50.0	16.0	6.0	80.0	190.0	093WU4080V



ECKWINKEL 20

3-WAY CONNECTION ANGLE 20

Ausführung	Zinkdruckguss, für Profil 20	Model	Zinc die-cast, for profile 20
Beschreibung	zur rechtwinkligen Verbindung von bis zu drei Aluminiumprofilen	Description	To connect up to three aluminum profiles at right angles
Material	Zinkdruckguss	Material	Zinc die-cast
Befestigung	Senkschrauben M5	Fastening	Countersunk screws M5
Liefereinheit	50 Stück	Pack Quantity	50 pieces

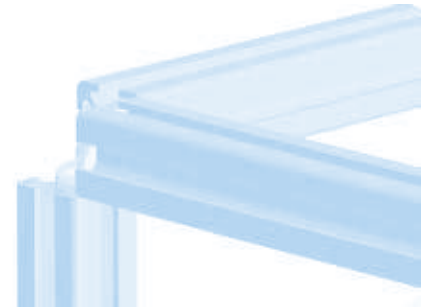
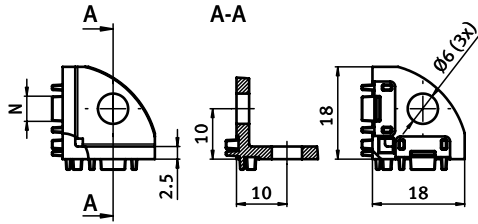

Eckwinkel 20 3-way Connection Angle 20	N	für Schraube for Screw	Gewicht [g] Weight [g]	Profil Profile	Teil-Nr. Part #
	5	M5	10.0	I	093WE201N05

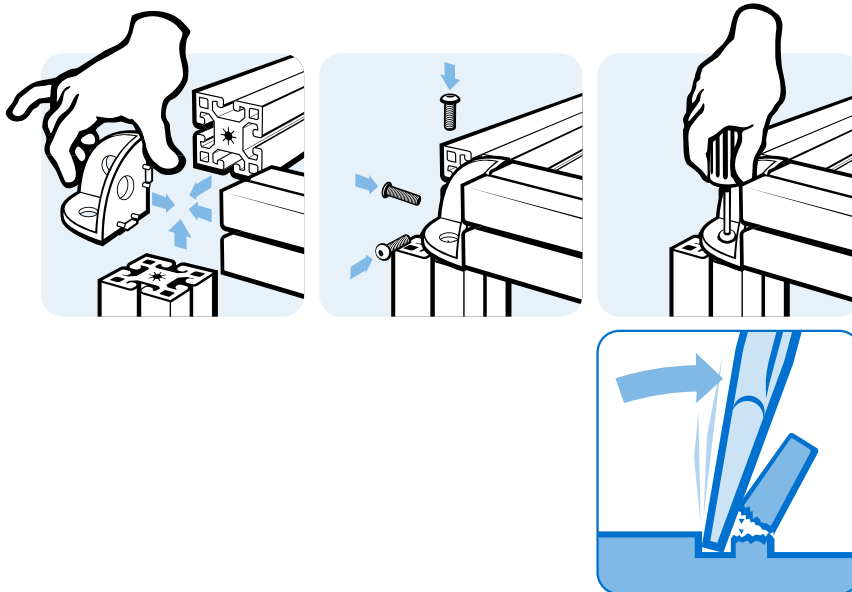



ABDECKKAPPE FÜR ECKWINKEL 20

COVER CAP FOR 3-WAY CONNECTION ANGLE 20

Ausführung	Kunststoff PA, Profil 20, Eckform	Model	Plastic PA, profile 20, angular
Beschreibung	zum Abdecken der offenen Seite des Eckwinkels	Description	To cover the 3-way connection angle
Material	Kunststoff PA, glasfaserverstärkt	Material	Plastic PA, glass fiber reinforced
Farbe	schwarz	Color	Black
Liefereinheit	50 Stück	Pack Quantity	50 pieces
Extras	weitere Farben auf Anfrage	Specials	Other colors on request

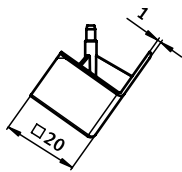
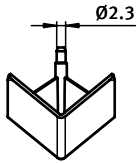

Abdeckkappe Eckform
 Cover Cap Angular

Gewicht [g]
 Weight [g]

Profil
 Profile

Teil-Nr.
 Part #

2.0

I

093WEA201A

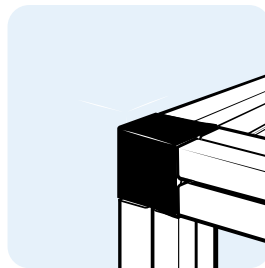
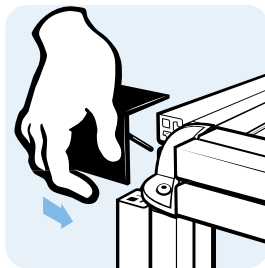



ABDECKKAPPE FÜR ECKWINKEL 20

COVER CAP FOR 3-WAY CONNECTION ANGLE 20

Ausführung	Kunststoff PA, Profil 20, Rundform	Model	Plastic PA, profile 20, round
Beschreibung	zum Abdecken der offenen Seite des Eckwinkels	Description	To cover the 3-way connection angle
Material	Kunststoff PA, glasfaserverstärkt	Material	Plastic PA, glass fiber reinforced
Farbe	schwarz	Color	Black
Liefereinheit	50 Stück	Pack Quantity	50 pieces
Extras	weitere Farben auf Anfrage	Specials	Other colors on request

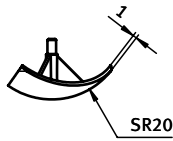
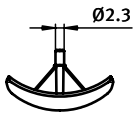

Abdeckkappe Rundform
Cover Cap Round

Gewicht [g]
Weight [g]

Profil
Profile

Teil-Nr.
Part #

1.0

I

093WEA201B

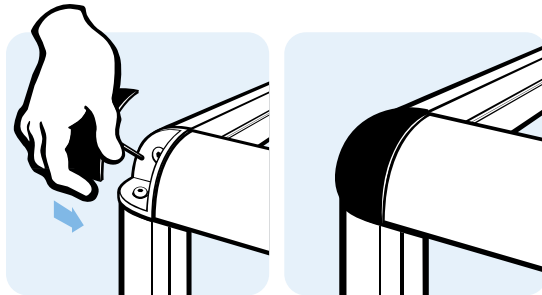



ECKWINKEL 20

3-WAY CONNECTION ANGLE 20

Ausführung	Zinkdruckguss, für Profil 20	Model	Zinc die-cast, for profile 20
Beschreibung	zur rechtwinkligen Verbindung von bis zu drei Aluminiumprofilen	Description	To connect up to three aluminum profiles at right angles
Material	Zinkdruckguss	Material	Zinc die-cast
Befestigung	Senkschrauben M6 und S6	Fastening	Countersunk screws M6 and S6
Liefereinheit	50 Stück	Pack Quantity	50 pieces

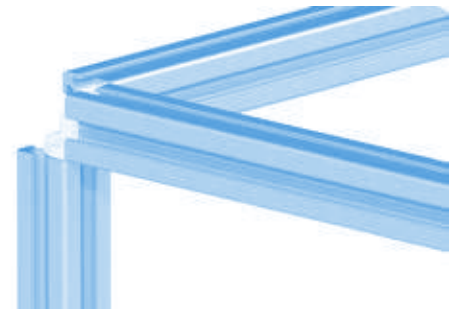
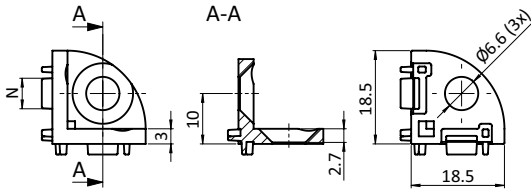

Eckwinkel 20 3-way Connection Angle 20	N	für Schraube for Screw	Gewicht [g] Weight [g]	Profil Profile	Teil-Nr. Part #
	6	M6 / S6	10.0	B	093WE202N06

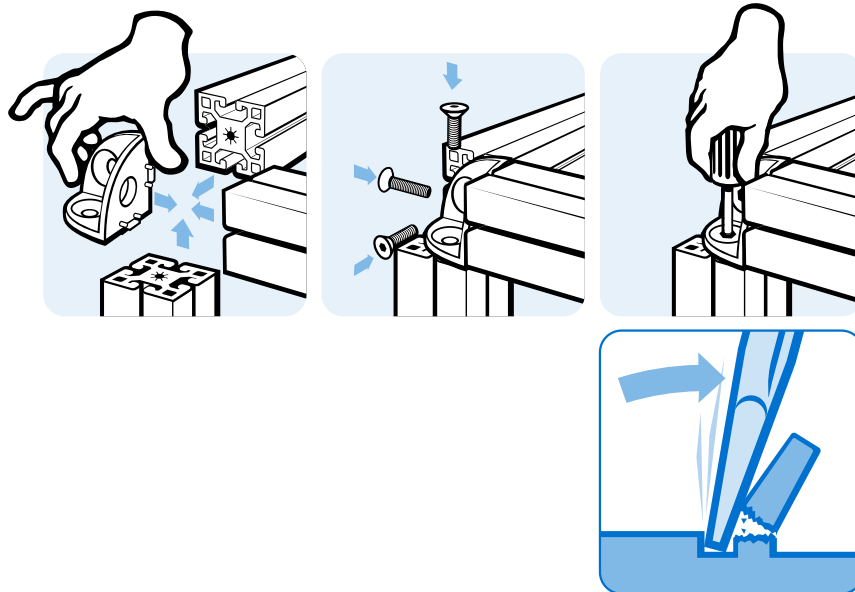



ABDECKKAPPE FÜR ECKWINKEL 20

COVER CAP FOR 3-WAY CONNECTION ANGLE 20

Ausführung	Kunststoff PA, Profil 20, Eckform	Model	Plastic PA, profile 20, angular
Beschreibung	zum Abdecken der offenen Seite des Eckwinkels	Description	To cover the 3-way connection angle
Material	Kunststoff PA, glasfaserverstärkt	Material	Plastic PA, glass fiber reinforced
Farbe	schwarz	Color	Black
Liefereinheit	50 Stück	Pack Quantity	50 pieces
Extras	weitere Farben auf Anfrage	Specials	Other colors on request

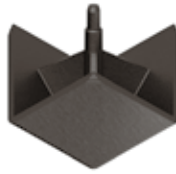
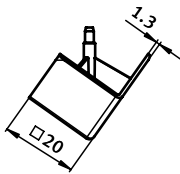
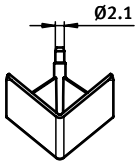

Abdeckkappe Eckform
Cover Cap Angular

Gewicht [g]
Weight [g]

Profil
Profile

Teil-Nr.
Part #

3.0

B

093WEA202A

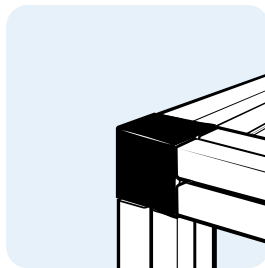
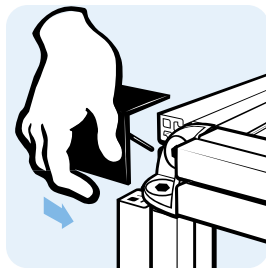



ABDECKKAPPE FÜR ECKWINKEL 20

COVER CAP FOR 3-WAY CONNECTION ANGLE 20

Ausführung	Kunststoff PA, Profil 20, Rundform	Model	Plastic PA, profile 20, round
Beschreibung	zum Abdecken der offenen Seite des Eckwinkels	Description	To cover the 3-way connection angle
Material	Kunststoff PA, glasfaserverstärkt	Material	Plastic PA, glass fiber reinforced
Farbe	schwarz	Color	Black
Liefereinheit	50 Stück	Pack Quantity	50 pieces
Extras	weitere Farben auf Anfrage	Specials	Other colors on request

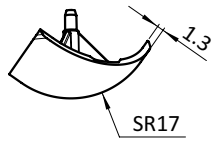
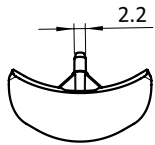

Abdeckkappe Rundform
 Cover Cap Round

Gewicht [g]
 Weight [g]

Profil
 Profile

Teil-Nr.
 Part #

2.0

B

093WEA202B

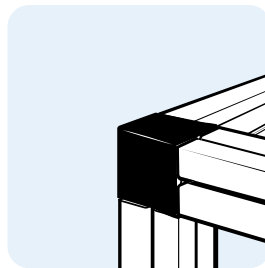
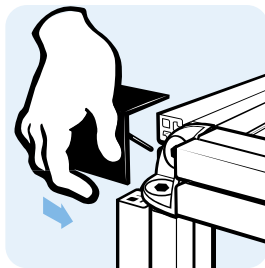



ECKWINKEL 30

3-WAY CONNECTION ANGLE 30

Ausführung	Zinkdruckguss, für Profil 30	Model	Zinc die-cast, for profile 30
Beschreibung	zur rechtwinkligen Verbindung von bis zu drei Aluminiumprofilen	Description	To connect up to three aluminum profiles at right angles
Material	Zinkdruckguss	Material	Zinc die-cast
Liefereinheit	50 Stück	Pack Quantity	50 pieces

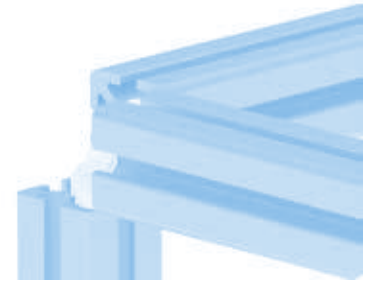
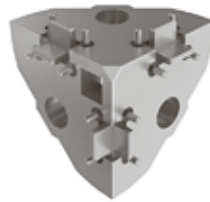
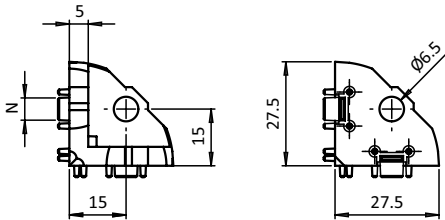

Eckwinkel 30 3-way Connection Angle 30	N	für Schraube for Screw	Gewicht [g] Weight [g]	Profil Profile	Teil-Nr. Part #
	6	M6	39.6	I	093WE302N06

4

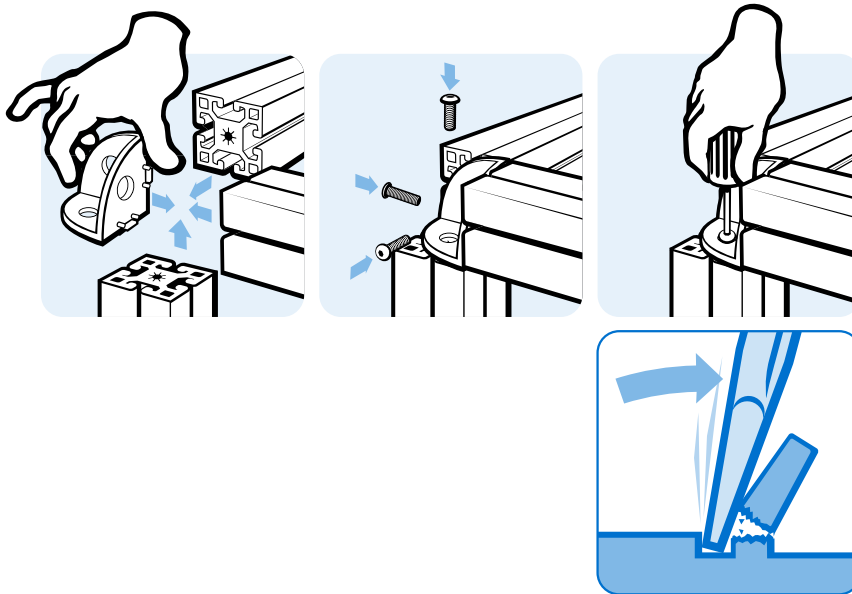



ABDECKKAPPE FÜR ECKWINKEL 30

COVER CAP FOR 3-WAY CONNECTION ANGLE 30

Ausführung	Kunststoff PA, Profil 30, Eckform	Model	Plastic PA, profile 30, angular
Beschreibung	zum Abdecken der offenen Seite des Eckwinkels	Description	To cover the 3-way connection angle
Material	Kunststoff PA, glasfaserverstärkt	Material	Plastic PA, glass fiber reinforced
Farbe	schwarz	Color	Black
Liefereinheit	50 Stück	Pack Quantity	50 pieces
Extras	weitere Farben auf Anfrage	Specials	Other colors on request

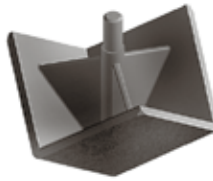
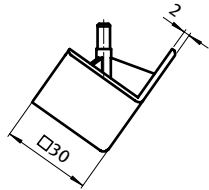
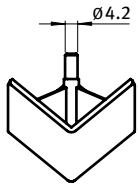

Abdeckkappe Eckform
Cover Cap Angular

Gewicht [g]
Weight [g]

Profil
Profile

Teil-Nr.
Part #

10.0

I

093WEA302A

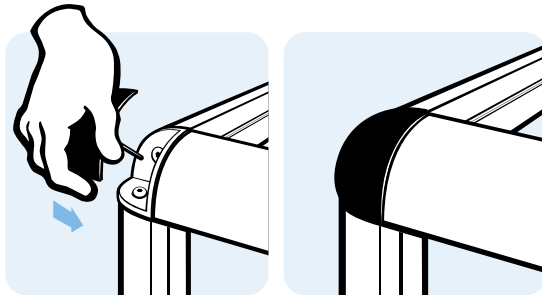



ABDECKKAPPE FÜR ECKWINKEL 30

COVER CAP FOR 3-WAY CONNECTION ANGLE 30

Ausführung	Kunststoff PA, Profil 30, Rundform	Model	Plastic PA, profile 30, round
Beschreibung	zum Abdecken der offenen Seite des Eckwinkels	Description	To cover the 3-way connection angle
Material	Kunststoff PA, glasfaserverstärkt	Material	Plastic PA, glass fiber reinforced
Farbe	schwarz	Color	Black
Liefereinheit	50 Stück	Pack Quantity	50 pieces
Extras	weitere Farben auf Anfrage	Specials	Other colors on request

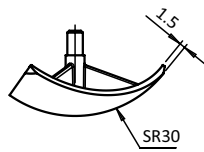
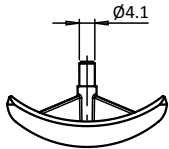

Abdeckkappe Rundform
Cover Cap Round

Gewicht [g]
Weight [g]

Profil
Profile

Teil-Nr.
Part #

4.0

I

093WEA302B

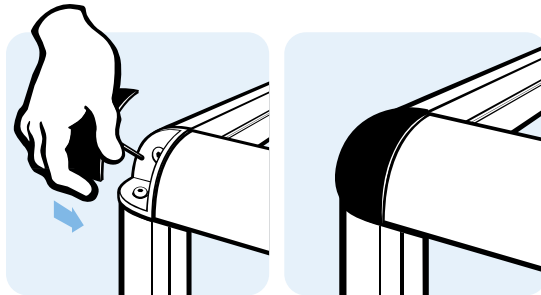



ECKWINKEL 30

3-WAY CONNECTION ANGLE 30

Ausführung Zinkdruckguss, für Profil 30
Beschreibung zur rechtwinkligen Verbindung von bis zu drei Aluminiumprofilen
Material Zinkdruckguss
Befestigung Senkschrauben M8
Liefereinheit 50 Stück
Hinweis passende Senkschraube siehe 093S0825C

Model Zinc die-cast, for profile 30
Description To connect up to three aluminum profiles at right angles
Material Zinc die-cast
Fastening Countersunk screws M8
Pack Quantity 50 pieces
Tip Compatible countersunk screw see 093S0825C

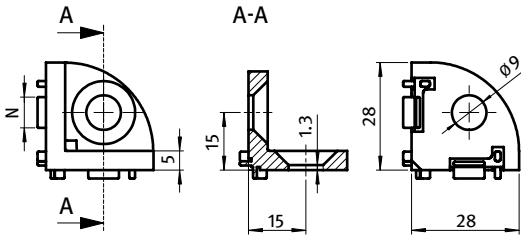

Eckwinkel 30
3-way Connection Angle 30

N

für Schraube
for Screw

Gewicht [g]
Weight [g]

Profil
Profile

Teil-Nr.
Part #

8

M8

39.0

B

093WE301N08

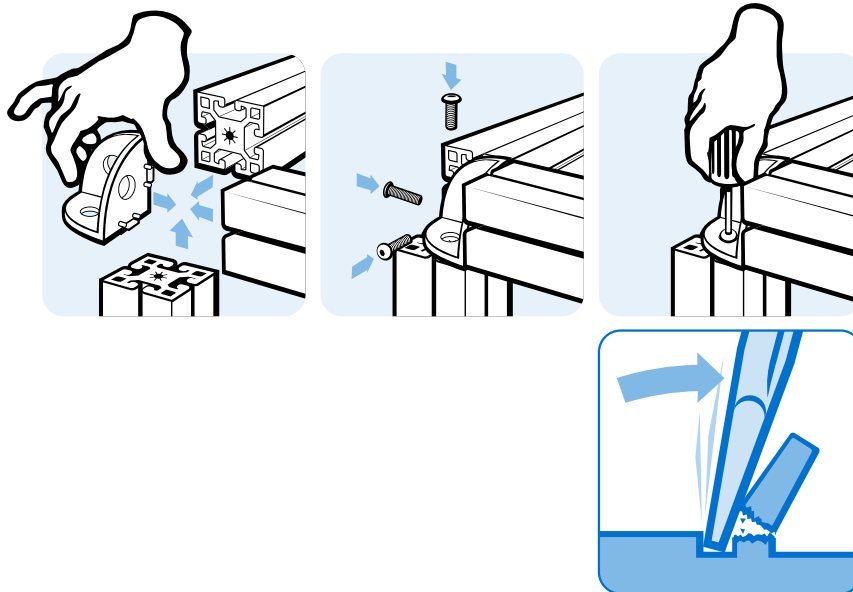



ABDECKKAPPE FÜR ECKWINKEL 30

COVER CAP FOR 3-WAY CONNECTION ANGLE 30

Ausführung	Kunststoff PA, Profil 30, Eckform	Model	Plastic PA, profile 30, angular
Beschreibung	zum Abdecken der offenen Seite des Eckwinkels	Description	To cover the 3-way connection angle
Material	Kunststoff PA, glasfaserverstärkt	Material	Plastic PA, glass fiber reinforced
Farbe	schwarz	Color	Black
Liefereinheit	50 Stück	Pack Quantity	50 pieces
Extras	weitere Farben auf Anfrage	Specials	Other colors on request

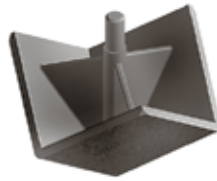
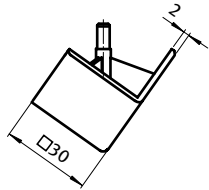
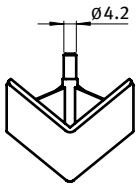

Abdeckkappe Eckform
Cover Cap Angular

Gewicht [g]
Weight [g]

Profil
Profile

Teil-Nr.
Part #

10.0

B

093WEA301A

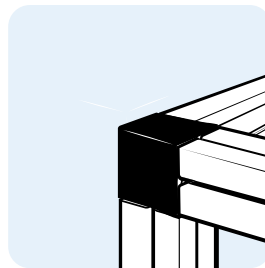
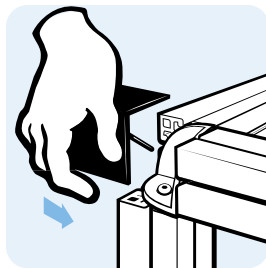



ABDECKKAPPE FÜR ECKWINKEL 30

COVER CAP FOR 3-WAY CONNECTION ANGLE 30

Ausführung	Kunststoff PA, Profil 30, Rundform	Model	Plastic PA, profile 30, round
Beschreibung	zum Abdecken der offenen Seite des Eckwinkels	Description	To cover the 3-way connection angle
Material	Kunststoff PA, glasfaserverstärkt	Material	Plastic PA, glass fiber reinforced
Farbe	schwarz	Color	Black
Liefereinheit	50 Stück	Pack Quantity	50 pieces
Extras	weitere Farben auf Anfrage	Specials	Other colors on request

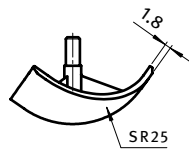
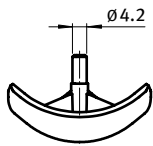

Abdeckkappe Rundform
 Cover Cap Round

Gewicht [g]
 Weight [g]

Profil
 Profile

Teil-Nr.
 Part #

8.0

B

093WEA301B

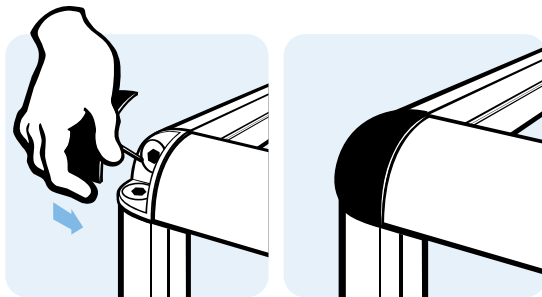



ABDECKKAPPE FÜR ECKWINKEL 30

COVER CAP FOR 3-WAY CONNECTION ANGLE 30

<p>Ausführung Kunststoff PA, Profil 30, 45°</p> <p>Beschreibung zum Abdecken der offenen Seite des Eckwinkels</p> <p>Material Kunststoff PA, glasfaserverstärkt</p> <p>Farbe schwarz</p> <p>Liefereinheit 50 Stück</p> <p>Extras weitere Farben auf Anfrage</p>	<p>Model Plastic PA, profile 30, 45°</p> <p>Description To cover the 3-way connection angle</p> <p>Material Plastic PA, glass fiber reinforced</p> <p>Color Black</p> <p>Pack Quantity 50 pieces</p> <p>Specials Other colors on request</p>
---	--

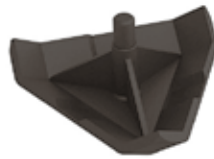
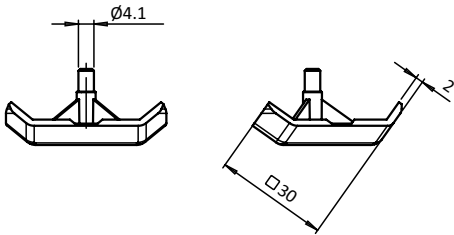

Abdeckkappe 45°
Cover Cap 45°

Gewicht [g]
Weight [g]

Profil
Profile

Teil-Nr.
Part #

4.0

B

093WEA301C

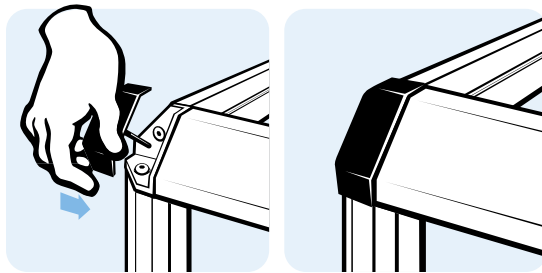



ECKWINKEL 38 - 1,5"

3-WAY CONNECTION ANGLE 38 - 1.5"

Ausführung	Zinkdruckguss, für Profil 1,5 Zoll	Model	Zinc die-cast, for profile 1.5 inch
Beschreibung	zur rechtwinkligen Verbindung von bis zu drei Aluminiumprofilen	Description	To connect up to three aluminum profiles at right angles
Material	Zinkdruckguss	Material	Zinc die-cast
Liefereinheit	50 Stück	Pack Quantity	50 pieces

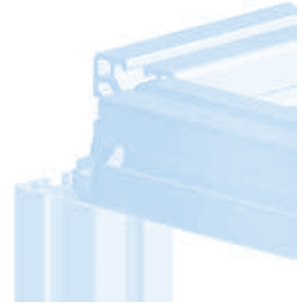
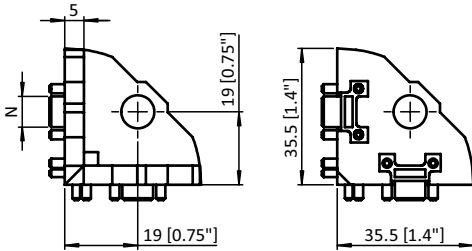

Eckwinkel 38 - 1,5" 3-way Connection Angle 38 - 1,5"	N	für Schraube for Screw	Gewicht [g] Weight [g]	Teil-Nr. Part #
	8	M8	67.0	093WE381N08

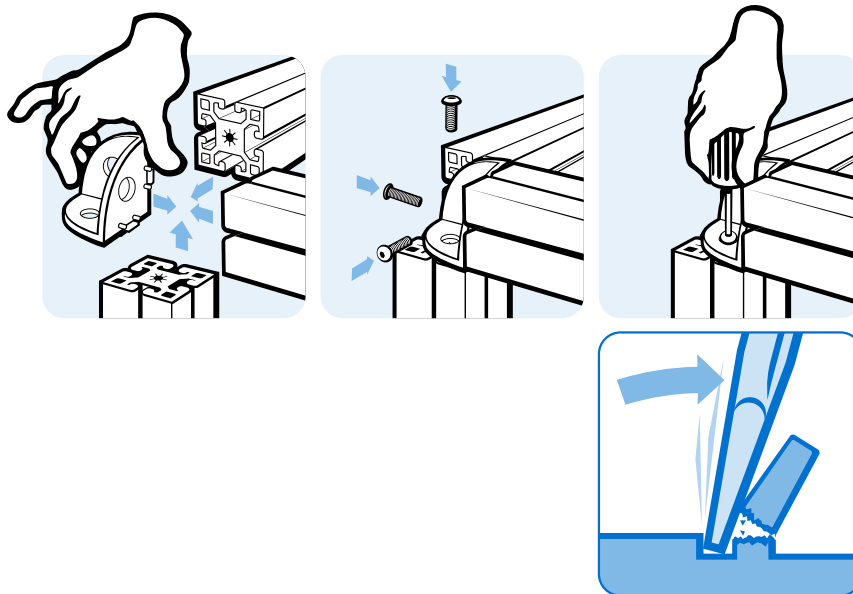



ABDECKKAPPE FÜR ECKWINKEL 38 - 1,5"

COVER CAP FOR 3-WAY CONNECTION ANGLE 38 - 1.5"

<p>Ausführung Kunststoff PA, Profil 1,5 Zoll, Rundform</p> <p>Beschreibung zum Abdecken der offenen Seite des Eckwinkels</p> <p>Material Kunststoff PA, glasfaserverstärkt</p> <p>Farbe schwarz</p> <p>Liefereinheit 50 Stück</p> <p>Extras weitere Farben auf Anfrage</p>	<p>Model Plastic PA, profile 1.5 inch, round</p> <p>Description To cover the 3-way connection angle</p> <p>Material Plastic PA, glass fiber reinforced</p> <p>Color Black</p> <p>Pack Quantity 50 pieces</p> <p>Specials Other colors on request</p>
--	--

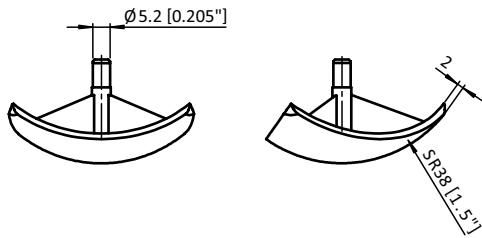

Abdeckkappe Rundform
Cover Cap Round

Gewicht [g]
Weight [g]

Teil-Nr.
Part #

8.0

093WEA381B

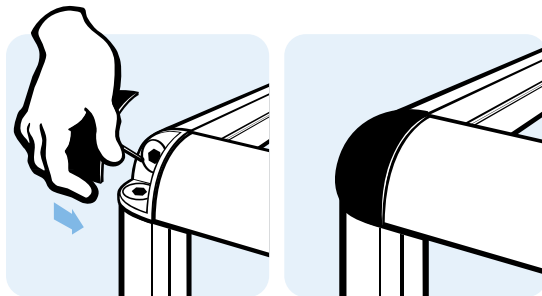



ABDECKKAPPE FÜR ECKWINKEL 38 - 1,5"

COVER CAP FOR 3-WAY CONNECTION ANGLE 38 - 1.5"

<p>Ausführung Kunststoff PA, Profil 1,5 Zoll, 45°</p> <p>Beschreibung zum Abdecken der offenen Seite des Eckwinkels</p> <p>Material Kunststoff PA, glasfaserverstärkt</p> <p>Farbe schwarz</p> <p>Liefereinheit 50 Stück</p> <p>Extras weitere Farben auf Anfrage</p>	<p>Model Plastic PA, profile 1.5 inch, 45°</p> <p>Description To cover the 3-way connection angle</p> <p>Material Plastic PA, glass fiber reinforced</p> <p>Color Black</p> <p>Pack Quantity 50 pieces</p> <p>Specials Other colors on request</p>
---	--

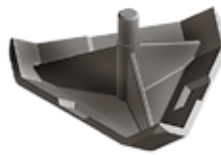
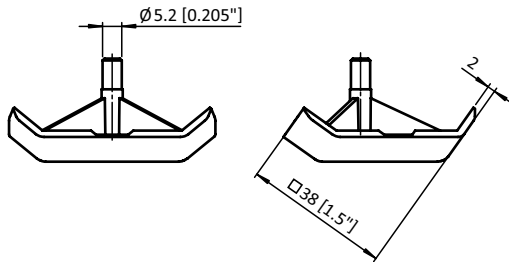

Abdeckkappe 45°
Cover Cap 45°

Gewicht [g]
Weight [g]

Teil-Nr.
Part #

12.0

093WEA381D

4

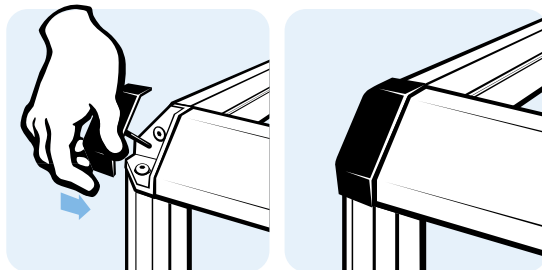



ECKWINKEL 40

3-WAY CONNECTION ANGLE 40

Ausführung	Zinkdruckguss, Profil 40	Model	Zinc die-cast, profile 40
Beschreibung	zur rechtwinkligen Verbindung von bis zu drei Aluminiumprofilen	Description	To connect up to three aluminum profiles at right angles
Material	Zinkdruckguss	Material	Zinc die-cast
Liefereinheit	50 Stück	Pack Quantity	50 pieces

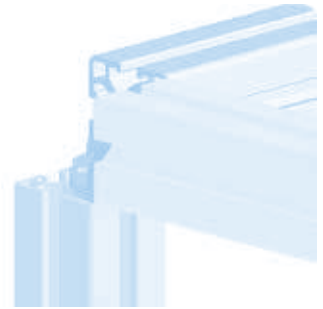
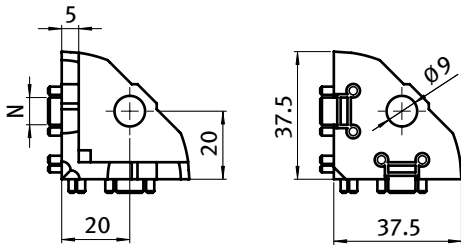

Eckwinkel 40 3-way Connection Angle 40	N	für Schraube for Screw	Gewicht [g] Weight [g]	Profil Profile	Teil-Nr. Part #
	8	M8	83.0	I	093WE402N08

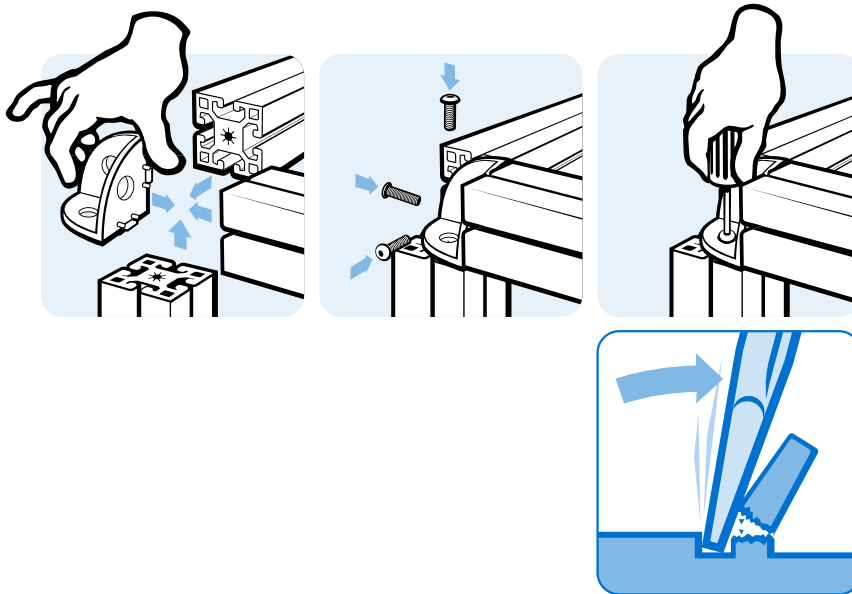

4



ABDECKKAPPE FÜR ECKWINKEL 40

COVER CAP FOR 3-WAY CONNECTION ANGLE 40

Ausführung Kunststoff PA, Profil 40, Eckform
Beschreibung zum Abdecken der offenen Seite des Eckwinkels
Material Kunststoff PA, glasfaserverstärkt
Farbe schwarz, grau
Liefereinheit 50 Stück
Extras weitere Farben auf Anfrage

Model Plastic PA, profile 40, angular
Description To cover the 3-way connection angle
Material Plastic PA, glass fiber reinforced
Color Black, gray
Pack Quantity 50 pieces
Specials Other colors on request

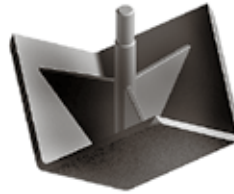
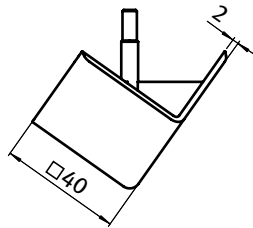
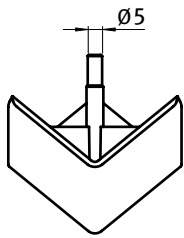

Abdeckkappe Eckform
 Cover Cap Angular

Gewicht [g]
 Weight [g]

Profil
 Profile

Teil-Nr.
 Part #

	Gewicht [g] Weight [g]	Profil Profile	Teil-Nr. Part #
schwarz <i>Black</i>	15.0	I	093WEA402A
grau ≈ RAL 7042 <i>Gray</i>	15.0	I	093WEA402AS01

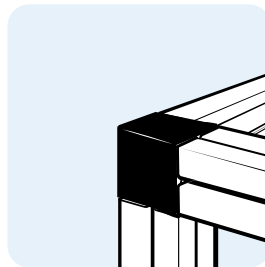
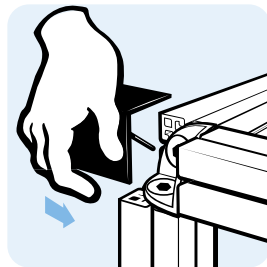



ABDECKKAPPE FÜR ECKWINKEL 40

COVER CAP FOR 3-WAY CONNECTION ANGLE 40

Ausführung	Kunststoff PA, Profil 40, Rundform	Model	Plastic PA, profile 40, round
Beschreibung	zum Abdecken der offenen Seite des Eckwinkels	Description	To cover the 3-way connection angle
Material	Kunststoff PA, glasfaserverstärkt	Material	Plastic PA, glass fiber reinforced
Farbe	schwarz	Color	Black
Liefereinheit	50 Stück	Pack Quantity	50 pieces
Extras	weitere Farben auf Anfrage	Specials	Other colors on request

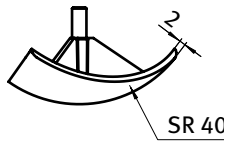
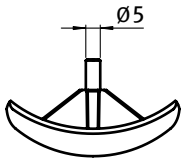

Abdeckkappe Rundform
Cover Cap Round

Gewicht [g]
Weight [g]

Profil
Profile

Teil-Nr.
Part #

8.0

I

093WEA402B

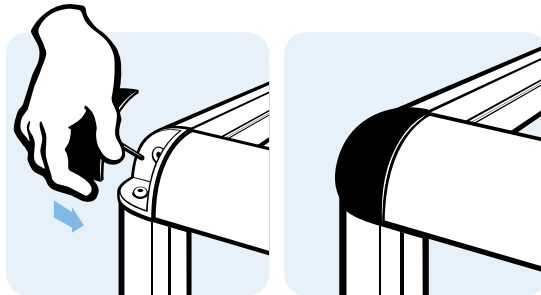



ABDECKKAPPE FÜR ECKWINKEL 40

COVER CAP FOR 3-WAY CONNECTION ANGLE 40

Ausführung	Kunststoff PA, Profil 40, 45°	Model	Plastic PA, profile 40, 45°
Beschreibung	zum Abdecken der offenen Seite des Eckwinkels	Description	To cover the 3-way connection angle
Material	Kunststoff PA, glasfaserverstärkt	Material	Plastic PA, glass fiber reinforced
Farbe	schwarz	Color	Black
Liefereinheit	50 Stück	Pack Quantity	50 pieces
Extras	weitere Farben auf Anfrage	Specials	Other colors on request

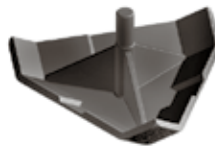
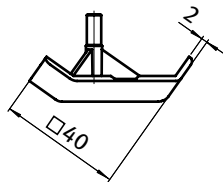
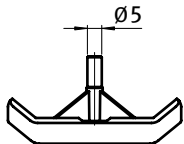

Abdeckkappe 45°
Cover Cap 45°

Gewicht [g]
Weight [g]

Profil
Profile

Teil-Nr.
Part #

8.0

I

093WEA402D

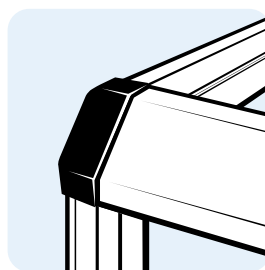
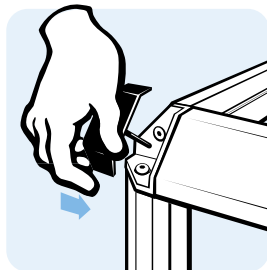



ECKWINKEL 40

3-WAY CONNECTION ANGLE 40

Ausführung	Zinkdruckguss, Profil 40	Model	Zinc die-cast, profile 40
Beschreibung	zur rechtwinkligen Verbindung von bis zu drei Aluminiumprofilen	Description	To connect up to three aluminum profiles at right angles
Material	Zinkdruckguss	Material	Zinc die-cast
Befestigung	Flachkopfschrauben M12 oder S12	Fastening	Flat head screw M12 or S12
Liefereinheit	50 Stück	Pack Quantity	50 pieces

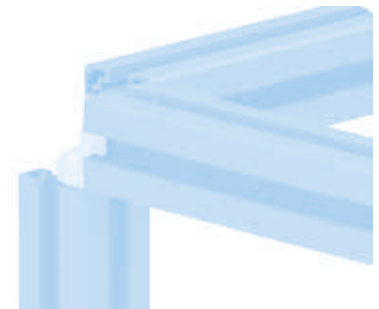
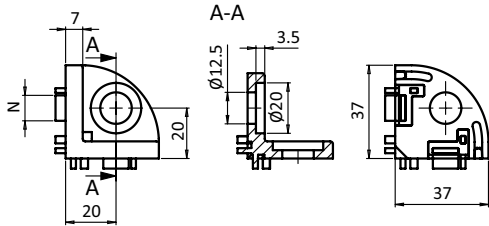

Eckwinkel 40
3-way Connection Angle 40

N

für Schraube
for Screw

Gewicht [g]
Weight [g]

Profil
Profile

Teil-Nr.
Part #

10

M12 / S12

81.0

B

093WE405N10

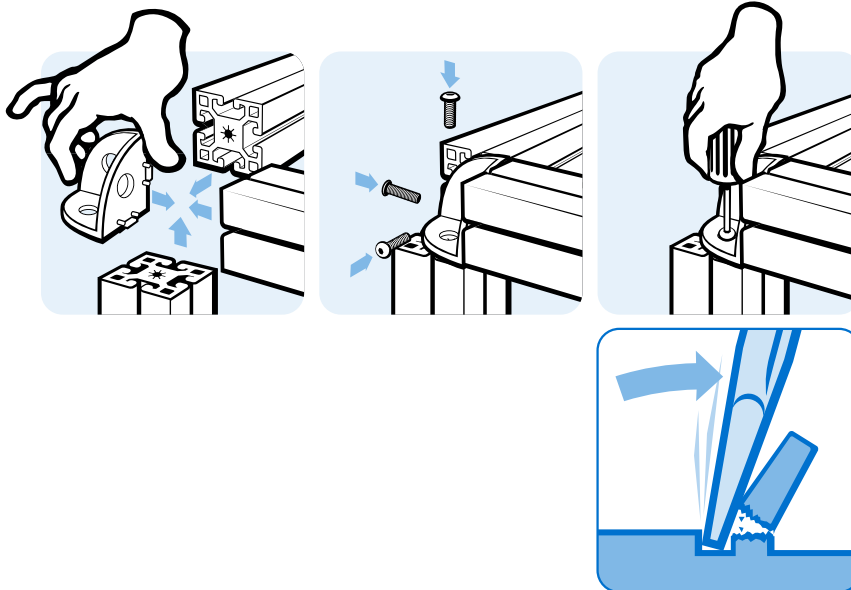



ABDECKKAPPE FÜR ECKWINKEL 40

COVER CAP FOR 3-WAY CONNECTION ANGLE 40

Ausführung Kunststoff PA, Profil 40, Eckform
Beschreibung zum Abdecken der offenen Seite des Eckwinkels
Material Kunststoff PA, glasfaserverstärkt
Farbe schwarz
Liefereinheit 50 Stück
Extras weitere Farben auf Anfrage

Model Plastic PA, profile 40, angular
Description To cover the 3-way connection angle
Material Plastic PA, glass fiber reinforced
Color Black
Pack Quantity 50 pieces
Specials Other colors on request

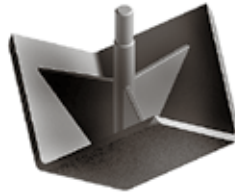
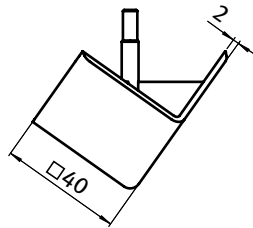
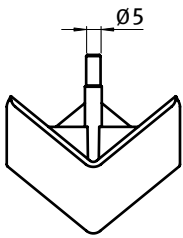

Abdeckkappe Eckform
 Cover Cap Angular

Gewicht [g]
 Weight [g]

Profil
 Profile

Teil-Nr.
 Part #

18.0

B

093WEA405A

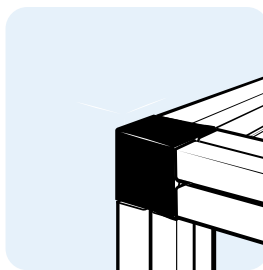
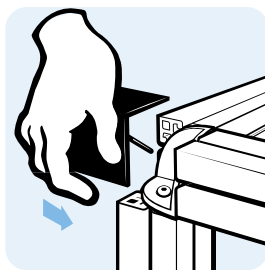



ABDECKKAPPE FÜR ECKWINKEL 40

COVER CAP FOR 3-WAY CONNECTION ANGLE 40

Ausführung	Kunststoff PA, Profil 40, Rundform	Model	Plastic PA, profile 40, round
Beschreibung	zum Abdecken der offenen Seite des Eckwinkels	Description	To cover the 3-way connection angle
Material	Kunststoff PA, glasfaserverstärkt	Material	Plastic PA, glass fiber reinforced
Farbe	schwarz	Color	Black
Liefereinheit	50 Stück	Pack Quantity	50 pieces
Extras	weitere Farben auf Anfrage	Specials	Other colors on request

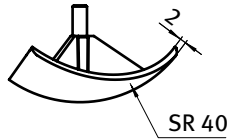
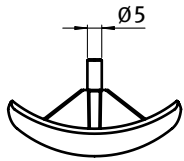

Abdeckkappe Rundform
Cover Cap Round

Gewicht [g]
Weight [g]

Profil
Profile

Teil-Nr.
Part #

18.0

B

093WEA405B

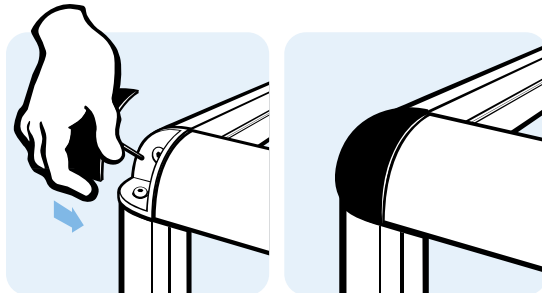



ECKWINKEL 45

3-WAY CONNECTION ANGLE 45

Ausführung	Zinkdruckguss, Profil 45	Model	Zinc die-cast, profile 45
Beschreibung	zur rechtwinkligen Verbindung von bis zu drei Aluminiumprofilen	Description	To connect up to three aluminum profiles at right angles
Material	Zinkdruckguss	Material	Zinc die-cast
Befestigung	Senkschrauben M12	Fastening	Countersunk screws M12
Liefereinheit	50 Stück	Pack Quantity	50 pieces

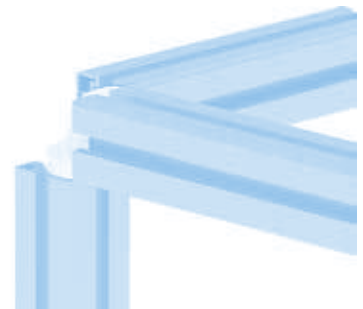
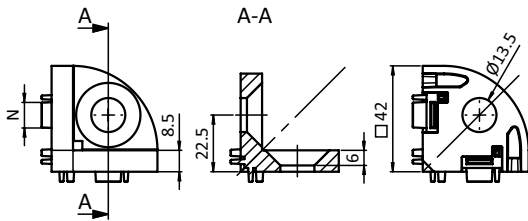

Eckwinkel 45
3-way Connection Angle 45

N

für Schraube
for Screw

Gewicht [g]
Weight [g]

Profil
Profile

Teil-Nr.
Part #

10

M12

132.0

B

093WE452N10

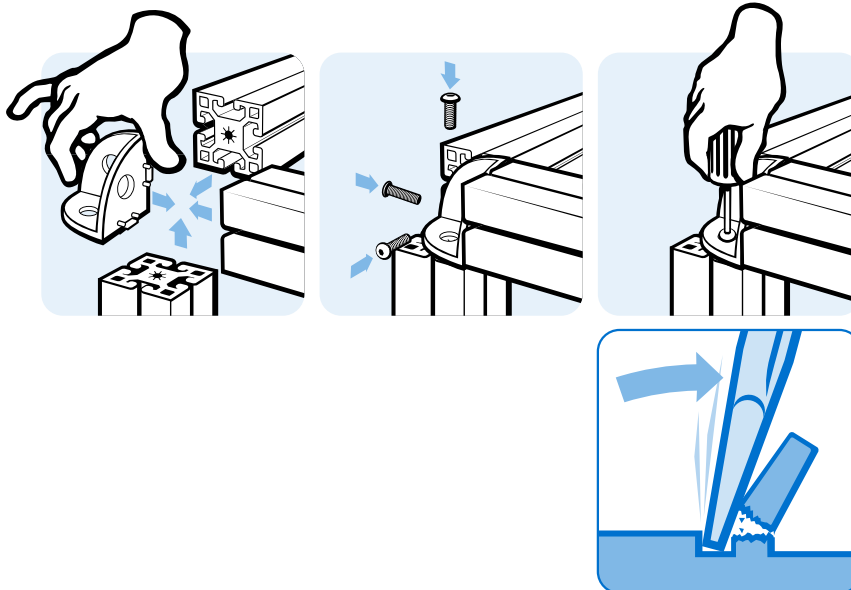



ABDECKKAPPE FÜR ECKWINKEL 45

COVER CAP FOR 3-WAY CONNECTION ANGLE 45

Ausführung	Kunststoff PA, Profil 45, Eckform	Model	Plastic PA, profile 45, angular
Beschreibung	zum Abdecken der offenen Seite des Eckwinkels	Description	To cover the 3-way connection angle
Material	Kunststoff PA, glasfaserverstärkt	Material	Plastic PA, glass fiber reinforced
Farbe	schwarz	Color	Black
Liefereinheit	50 Stück	Pack Quantity	50 pieces
Extras	weitere Farben auf Anfrage	Specials	Other colors on request

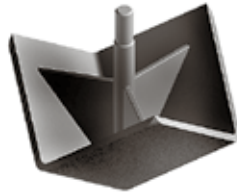
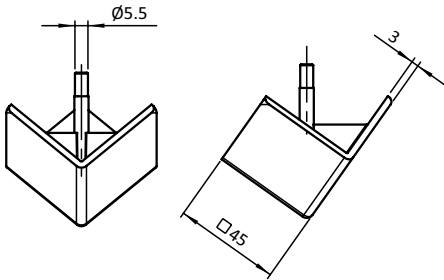

Abdeckkappe Eckform
Cover Cap Angular

Gewicht [g]
Weight [g]

Profil
Profile

Teil-Nr.
Part #

28.0

B

093WEA452A

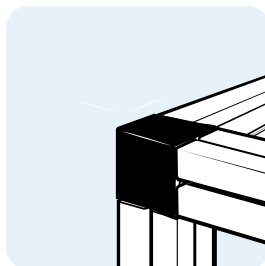
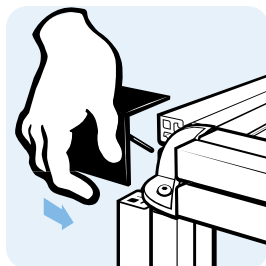



ABDECKKAPPE FÜR ECKWINKEL 45

COVER CAP FOR 3-WAY CONNECTION ANGLE 45

Ausführung	Kunststoff PA, Profil 45, Rundform	Model	Plastic PA, profile 45, round
Beschreibung	zum Abdecken der offenen Seite des Eckwinkels	Description	To cover the 3-way connection angle
Material	Kunststoff PA, glasfaserverstärkt	Material	Plastic PA, glass fiber reinforced
Farbe	schwarz	Color	Black
Liefereinheit	50 Stück	Pack Quantity	50 pieces
Extras	weitere Farben auf Anfrage	Specials	Other colors on request

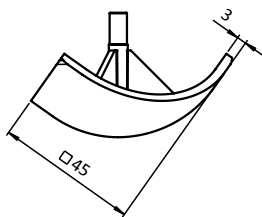
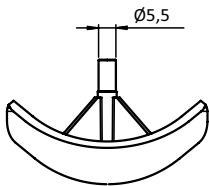

Abdeckkappe Rundform
Cover Cap Round

Gewicht [g]
Weight [g]

Profil
Profile

Teil-Nr.
Part #

16.0

B

093WEA452B

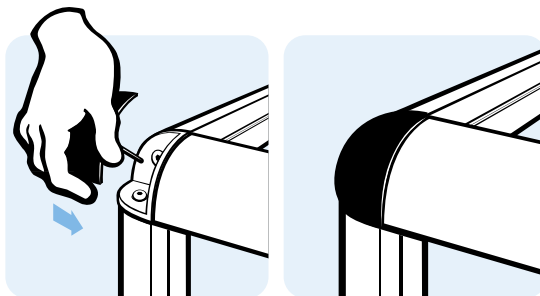



RAHMEN-ECKVERBINDERPLATTE

FRAME CORNER CONNECTOR PLATE

Ausführung	Kunststoff PA, Rahmenprofil 22,5 × 30	Model	Plastic PA, frame profile 22.5 × 30
Beschreibung	zur rechtwinkligen Verbindung von zwei Rahmenprofilen 22,5 × 30; ⚡ elektrostatisch entladend	Description	To connect two frame profiles 22.5 × 30 at right angles; ⚡ electrostatically discharging
Material	Eckverbinderplatte: Kunststoff PA, kohlefaserverstärkt Montageset: Stahl	Material	Corner connector plate: Plastic PA, carbon fiber reinforced Assembly set: Steel
Farbe	Eckverbinderplatte: schwarz	Color	Corner connector plate: Black
Montageset	1 selbstformende Senkkopfschraube S8 × 25, 1 Senkkopfschraube DIN 7991 - M8 × 16, 1 Vierkantmutter DIN 562 - M8	Assembly Set	1 self forming countersunk screw S8 × 25, 1 countersunk screw DIN 7991 - M8 × 16, 1 square nut DIN 562 - M8
Liefereinheit	10 Stück	Pack Quantity	10 pieces
Hinweis	* passende selbstformende Senkkopfschraube S8 × 25 siehe Seite 417	Tip	* Compatible self forming countersunk screw S8 × 25 see page 500

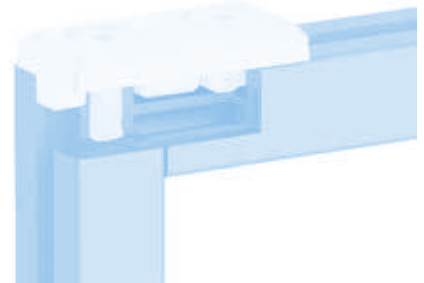
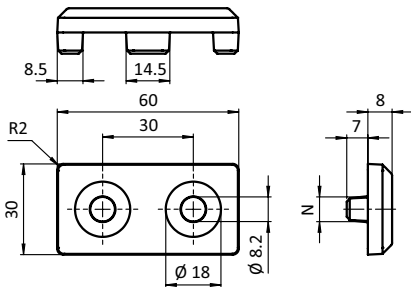

Rahmen-Eckverbinderplatte <i>Frame Corner Connector Plate</i>	N	Gewicht [g] <i>Weight [g]</i>	Profil <i>Profile</i>	Teil-Nr. <i>Part #</i>
	8	12.0		* 093VB3060N08
inkl. Montageset <i>With assembly set</i>	8	37.0	B	093VB3060N08S01

RAHMEN-ECKVERBINDER 20 × 40 (SET)

FRAME CORNER CONNECTOR 20 × 40 (SET)

Ausführung	Aluminiumdruckguss	Model	Aluminum die-cast
Beschreibung	zur rechtwinkligen Verbindung von zwei Rahmenprofilen 20 × 40	Description	To connect two aluminum frame profiles 20 × 40 at right angles
Material	Rahmen-Eckverbinder: Aludruckguss Schrauben: Stahl Abdeckkappe: Kunststoff PA, glasfaserverstärkt	Material	Frame corner connector: Aluminum die-cast Screws: Steel Cover cap: Plastic PA, glass fiber reinforced
Farbe	Rahmen-Eckverbinder: alufarbig Abdeckkappe: grau ≈ RAL 7042	Color	Frame corner connector: Alu color Cover cap: Gray ≈ RAL 7042
Set	1 Rahmen-Eckverbinder 20 × 40 - Nut 8, 4 selbstfurchende Schrauben - M4 × 20, 1 Abdeckkappe	Set	1 frame corner connector 20 × 40 - slot 8, 4 self-tapping screws - M4 × 20, 1 cover cap
Liefereinheit	10 Stück	Pack Quantity	10 pieces



Rahmen-Eckverbinder 20 × 40 (Set) Frame Corner Connector 20 × 40 (Set)	N	Gewicht [g/m] Weight [g/m]	Profil Profile	Teil-Nr. Part #
	8	50.8	I	093WF20401N08S01



RAHMEN-ECKVERBINDER 22,5 × 45 (SET)

FRAME CORNER CONNECTOR 22.5 × 45 (SET)

Ausführung	Aluminiumdruckguss	Model	Aluminum die-cast
Beschreibung	zur rechtwinkligen Verbindung von zwei Rahmenprofilen 22,5 × 45	Description	To connect two aluminum frame profiles 22.5 × 45 at right angles
Material	Rahmen-Eckverbinder: Aludruckguss Schrauben: Stahl	Material	Frame corner connector: Aluminum die-cast Screws: Steel
Set	1 Rahmen-Eckverbinder 22,5 × 45 - Nut 10, 4 Schrauben DIN 7982 - 4,8 × 32	Set	1 frame corner connector 22.5 × 45 - slot 10, 4 screws DIN 7982 - 4.8 × 32
Liefereinheit	10 Stück	Pack Quantity	10 pieces
Extras	weitere Oberflächen, weitere Farben auf Anfrage	Specials	Other surfaces, other colors on request

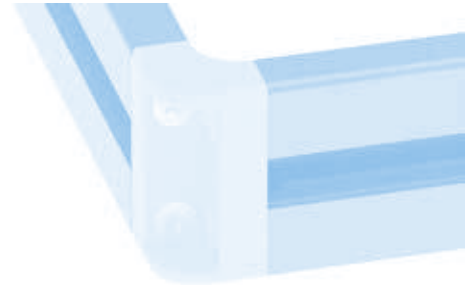
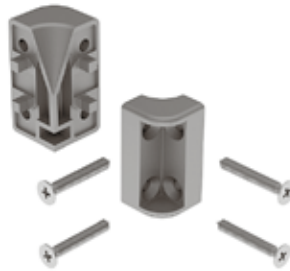
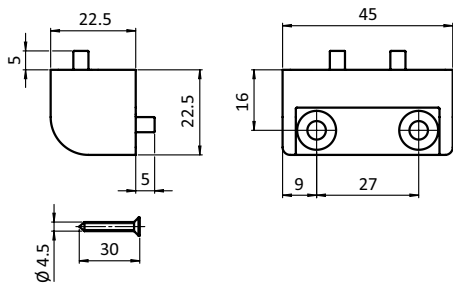

Rahmen-Eckverbinder 22,5 × 45 (Set)
Frame Corner Connector 22.5 × 45 (Set)

Nut
Slot

Gewicht [g/m]
Weight [g/m]

Profil
Profile

Teil-Nr.
Part #

10

74.0

B

093WF22451N10S01



DICHTSCHNUR

SEALING CORD

Ausführung	Durchmesser 6 mm	Model	Diameter 6 mm
Beschreibung	zum spielfreien Abdichten von Flächenelementen in Rahmenprofilen	Description	To seal panels in frame profiles without clearance
Material	Gummi NBR	Material	Rubber NBR
Farbe	grau	Color	gray
Liefereinheit	200 Meter (Spule)	Pack Quantity	200 meter (spool)

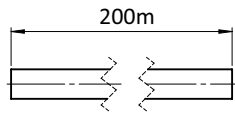
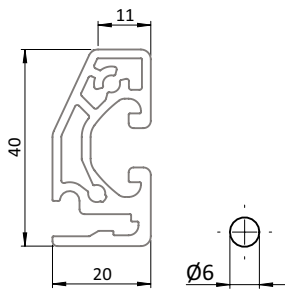

Dichtschnur
Sealing Cord

Gewicht [g/m]
Weight [g/m]

Teil-Nr.
Part #

10.0

340ME467



WÜRFELVERBINDER 2D

CUBE CONNECTOR 2D

Ausführung	Aluminiumdruckguss, mit Abdeckkappen	Model	Aluminum die-cast, with cover caps
Beschreibung	zur rechtwinkligen Verbindung von zwei Aluprofilen; mit Abdeckkappen zum Verschließen der Öffnungen	Description	To connect two aluminium profiles at right angles; with cover caps to cover the bores
Material	Würfelverbinder: Aluminiumdruckguss Abdeckkappen: Kunststoff PA Montageset: Stahl	Material	Cube connector: Aluminum die-cast Cover caps: Plastic PA Assembly set: Steel
Montageset 1	2 Schrauben ISO 7380 - M5 × 14	Assembly Set 1	2 screws ISO 7380 - M5 × 14
Liefereinheit	10 Stück	Pack Quantity	10 pieces

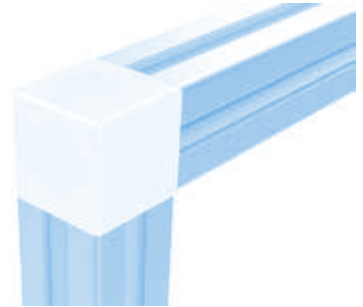
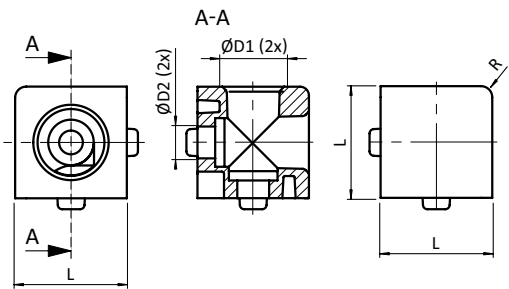

Würfelverbinder 2D <i>Cube Connector 2D</i>	Würfelverbinder 2D <i>Cube Connector 2D</i>	D1 [mm]	D2 [mm]	L [mm]	N	R [mm]	Gewicht [g] <i>Weight [g]</i>	Profil <i>Profile</i>	Teil-Nr. <i>Part #</i>
	blank / schwarz <i>Plain / black</i>	12.0	6.3	20.0	6	1.5	10.0	B	093WW201N06R
	alufarbig / alufarbig <i>Alu color / alu color</i>	12.0	5.2	20.0	5	1.5	10.0	I	093WW201N05
inkl. Montageset 1 <i>With assembly set 1</i>	alufarbig / alufarbig <i>Alu color / alu color</i>	12.0	5.2	20.0	5	1.5	16.0	I	093WW201N05S01

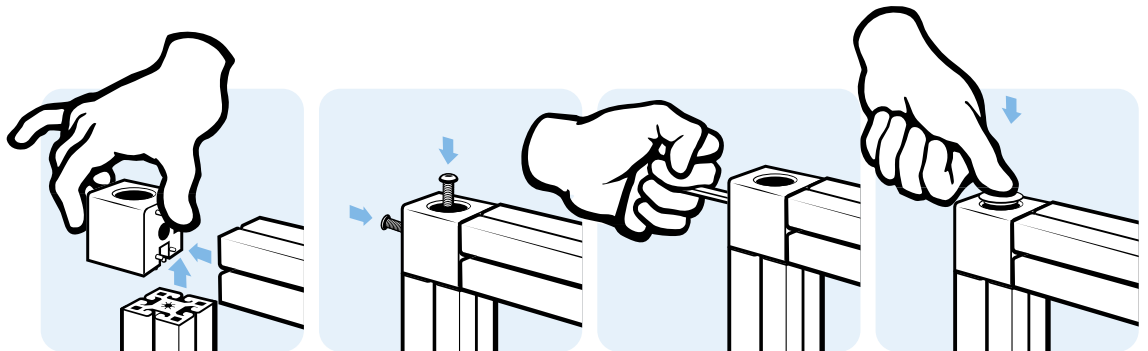

WÜRFELVERBINDER 3D

CUBE CONNECTOR 3D

Ausführung	Aluminiumdruckguss, mit Abdeckkappen	Model	Aluminum die-cast, with cover caps
Beschreibung	zur rechtwinkligen Verbindung von drei Aluminiumprofilen; mit Abdeckkappen zum Verschließen der Öffnungen	Description	To connect three aluminum profiles at right angles; with cover caps to cover the bores
Material	Würfelverbinder: Aluminiumdruckguss Abdeckkappen: Kunststoff PA Montageset: Stahl	Material	Cube connector: Aluminum die-cast Cover caps: Plastic PA Assembly set: Steel
Montageset 1	2 Schrauben ISO 7380 - M5 x 14	Assembly Set 1	2 screws ISO 7380 - M5 x 14
Liefereinheit	10 Stück	Pack Quantity	10 pieces

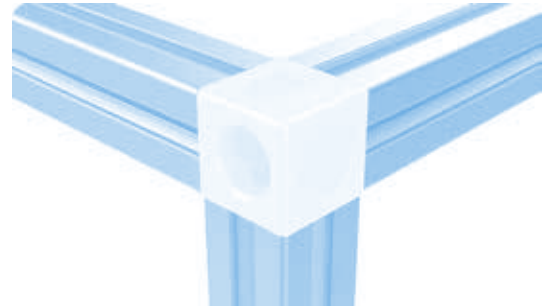
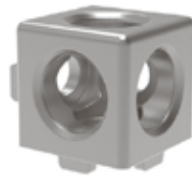
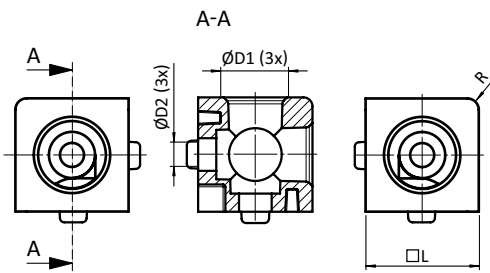

Würfelverbinder 3D <i>Cube Connector 3D</i>	Würfelverbinder 3D <i>Cube Connector 3D</i>	D1 [mm]	D2 [mm]	L [mm]	N	R [mm]	Gewicht [g] <i>Weight [g]</i>	Profil <i>Profile</i>	Teil-Nr. <i>Part #</i>
	blank / schwarz <i>Plain / black</i>	12.0	6.3	20.0	6	1.5	10.0	B	093WW202N06R
	alufarbig / alufarbig <i>Alu color / alu color</i>	12.0	5.2	20.0	5	1.5	10.0	I	093WW202N05
inkl. Montageset 1 <i>With assembly set 1</i>	alufarbig / alufarbig <i>Alu color / alu color</i>	12.0	5.2	20.0	5	1.5	19.0	I	093WW202N05S01

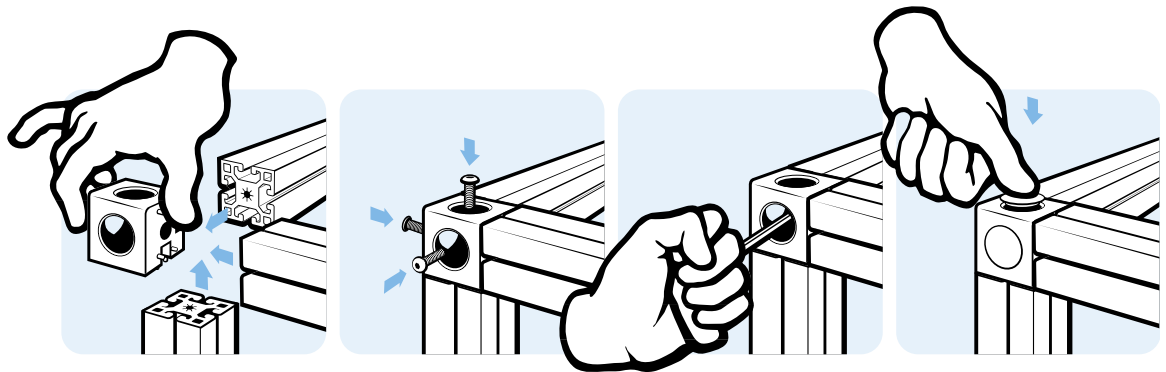



WÜRFELVERBINDER 2D

CUBE CONNECTOR 2D

Ausführung	Aluminiumdruckguss, mit Abdeckkappen	Model	Aluminum die-cast, with cover caps
Beschreibung	zur rechtwinkligen Verbindung von zwei Aluprofilen; mit Abdeckkappen zum Verschließen der Öffnungen	Description	To connect two aluminium profiles at right angles; with cover caps to cover the bores
Material	Würfelverbinder: Aluminiumdruckguss Abdeckkappen: Kunststoff PA Montageset: Stahl	Material	Cube connector: Aluminum die-cast Cover caps: Plastic PA Assembly set: Steel
Montageset 2	2 Schrauben ISO 7380 - UNC 1/4-20x1"	Assembly Set 2	2 screws ISO 7380 - UNC 1/4-20x1"
Liefereinheit	10 Stück	Pack Quantity	10 pieces

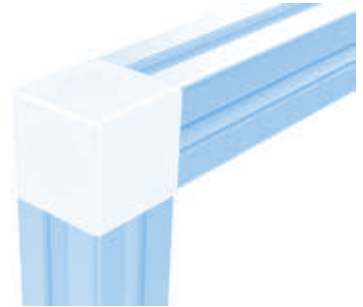
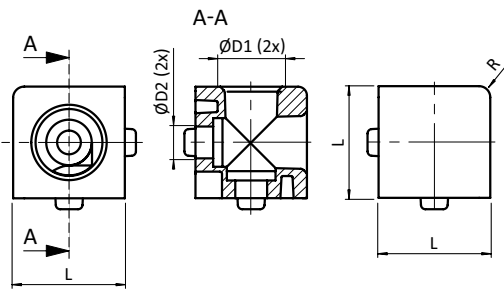

Würfelverbinder 2D Cube Connector 2D	Würfelverbinder 2D Cube Connector 2D	D1 [mm]	D2 [mm]	L [mm]	N	R [mm]	Gewicht [g] Weight [g]	Profil Profile	Teil-Nr. Part #
alufarbig / alufarbig	Alu color / alu color	12.0	7.2	25.2 (1")	6	2.0	25.0		093WW251N06
inkl. Montageset 2 With assembly set 2	alufarbig / alufarbig	Alu color / alu color	12.0	7.2	25.2 (1")	6	29.0		093WW251N06S01

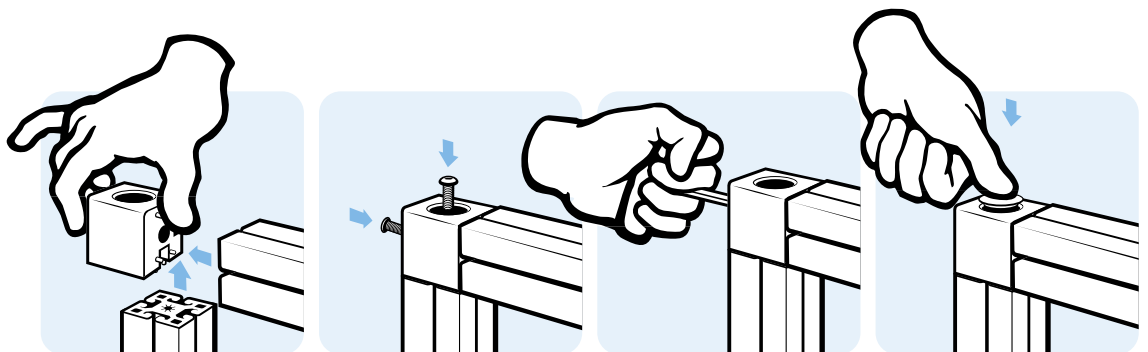



WÜRFELVERBINDER 3D

CUBE CONNECTOR 3D

Ausführung	Aluminiumdruckguss, mit Abdeckkappen	Model	Aluminum die-cast, with cover caps
Beschreibung	zur rechtwinkligen Verbindung von drei Aluminiumprofilen; mit Abdeckkappen zum Verschließen der Öffnungen	Description	To connect three aluminum profiles at right angles; with cover caps to cover the bores
Material	Würfelverbinder: Aluminiumdruckguss Abdeckkappen: Kunststoff PA Montageset: Stahl	Material	Cube connector: Aluminum die-cast Cover caps: Plastic PA Assembly set: Steel
Montageset 2	3 Schrauben ISO 7380 - UNC 1/4-20x1"	Assembly Set 2	3 screws ISO 7380 - UNC 1/4-20x1"
Liefereinheit	10 Stück	Pack Quantity	10 pieces

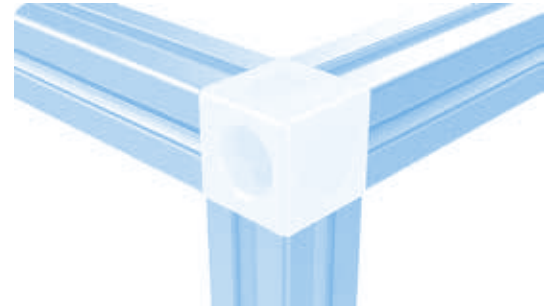
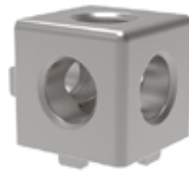
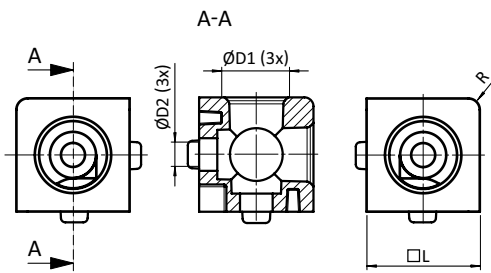

Würfelverbinder 3D Cube Connector 3D	alufarbig / alufarbig Alu color / alu color	alufarbig / alufarbig Alu color / alu color	D1 [mm]	D2 [mm]	L [mm]	N [mm]	R [mm]	Gewicht [g] Weight [g]	Profil Profile	Teil-Nr. Part #
			12.0	7.2	25.2 (1")	6	2.0	24.0		093WW252N06
inkl. Montageset 2 With assembly set 2			12.0	7.2	25.2 (1")	6	2.0	29.0		093WW252N06S01

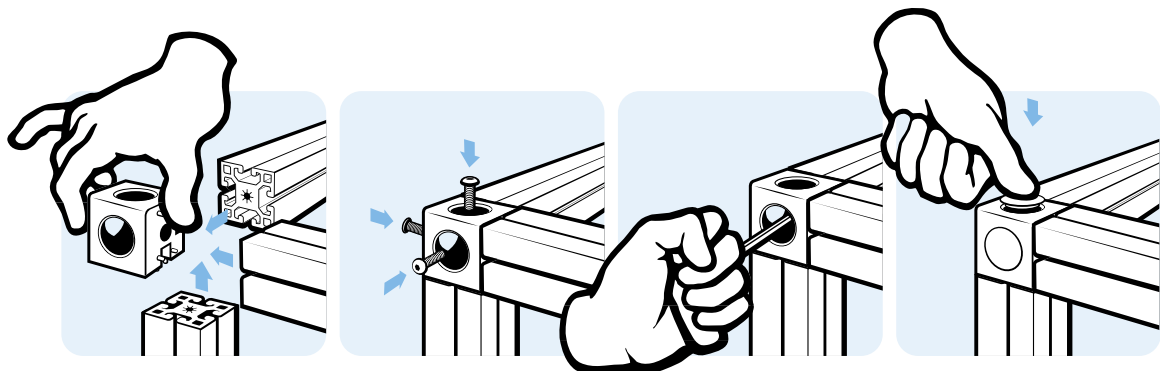



WÜRFELVERBINDER 2D

CUBE CONNECTOR 2D

Ausführung	Aluminiumdruckguss, mit Abdeckkappen	Model	Aluminum die-cast, with cover caps
Beschreibung	zur rechtwinkligen Verbindung von zwei Aluprofilen; mit Abdeckkappen zum Verschließen der Öffnungen	Description	To connect two aluminium profiles at right angles; with cover caps to cover the bores
Material	Würfelverbinder: Aluminiumdruckguss Abdeckkappen: Kunststoff PA Montageset: Stahl	Material	Cube connector: Aluminum die-cast Cover caps: Plastic PA Assembly set: Steel
Montageset 3	2 selbstformende Schrauben S8 × 25 - SW 5	Assembly Set 3	2 self-forming screws S8 × 25 - SW 5
Liefereinheit	10 Stück	Pack Quantity	10 pieces

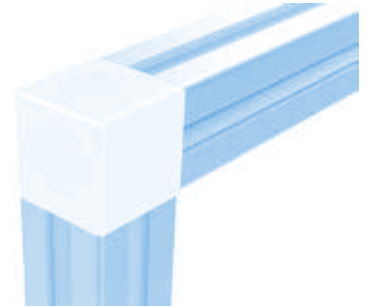
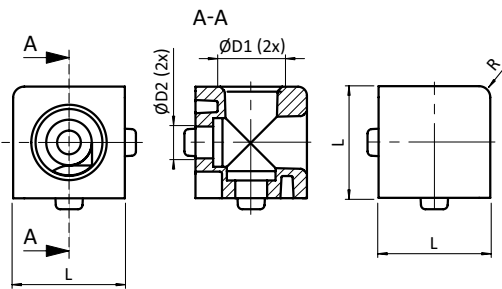

Würfelverbinder 2D <i>Cube Connector 2D</i>	Würfelverbinder 2D <i>Cube Connector 2D</i>	D1 [mm]	D2 [mm]	L [mm]	N	R [mm]	Gewicht [g] <i>Weight [g]</i>	Profil <i>Profile</i>	Teil-Nr. <i>Part #</i>
	blank / schwarz <i>Plain / black</i>	18.0	9.0	30.0	8	2.0	38.5	B	093WW303N08R
inkl. Montageset 3 <i>With assembly set 3</i>	blank / schwarz <i>Plain / black</i>	18.0	9.0	30.0	8	2.0	16.0	B	093WW303N08RS
	alufarbig / alufarbig <i>Alu color / alu color</i>	18.0	9.0	30.0	8	2.0	38.5	B	093WW303N08
inkl. Montageset 3 <i>With assembly set 3</i>	alufarbig / alufarbig <i>Alu color / alu color</i>	18.0	9.0	30.0	8	2.0	16.0	B	093WW303N08S

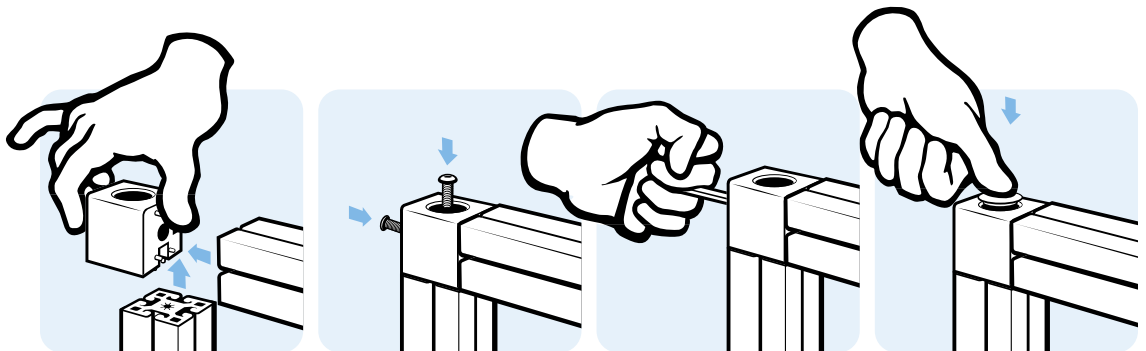

WÜRFELVERBINDER 3D

CUBE CONNECTOR 3D

Ausführung	Aluminiumdruckguss, mit Abdeckkappen	Model	Aluminum die-cast, with cover caps
Beschreibung	zur rechtwinkligen Verbindung von drei Aluminiumprofilen; mit Abdeckkappen zum Verschließen der Öffnungen	Description	To connect three aluminum profiles at right angles; with cover caps to cover the bores
Material	Würfelverbinder: Aluminiumdruckguss Abdeckkappen: Kunststoff PA Montageset: Stahl	Material	Cube connector: Aluminum die-cast Cover caps: Plastic PA Assembly set: Steel
Montageset 3	3 selbstformende Schrauben S8 × 25 - SW 5	Assembly Set 3	3 self-forming screws S8 × 25 - SW 5
Liefereinheit	10 Stück	Pack Quantity	10 pieces

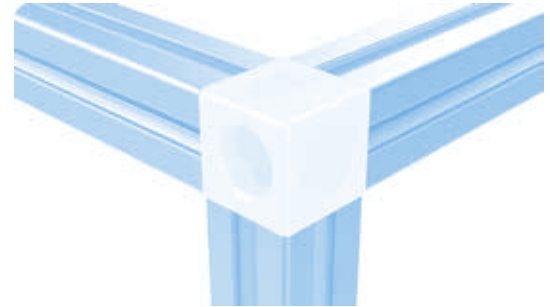
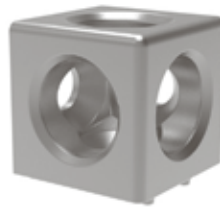
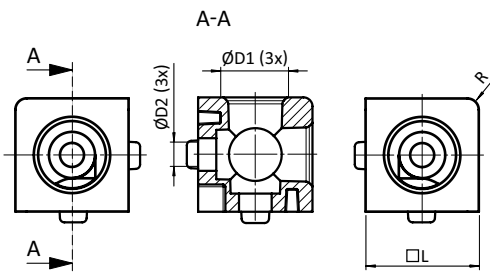

Würfelverbinder 3D <i>Cube Connector 3D</i>	Würfelverbinder 3D <i>Cube Connector 3D</i>	D1 [mm]	D2 [mm]	L [mm]	N	R [mm]	Gewicht [g] <i>Weight [g]</i>	Profil <i>Profile</i>	Teil-Nr. <i>Part #</i>
	blank / schwarz <i>Plain / black</i>	18.0	9.0	30.0	8	2.0	38.5	B	093WW304N08R
inkl. Montageset 3 <i>With assembly set 3</i>	blank / schwarz <i>Plain / black</i>	18.0	9.0	30.0	8	2.0	50.0	B	093WW304N08S
	alufarbig / alufarbig <i>Alu color / alu color</i>	18.0	9.0	30.0	8	2.0	38.5	B	093WW304N08
inkl. Montageset 3 <i>With assembly set 3</i>	alufarbig / alufarbig <i>Alu color / alu color</i>	18.0	9.0	30.0	8	2.0	50.0	B	093WW304N08S

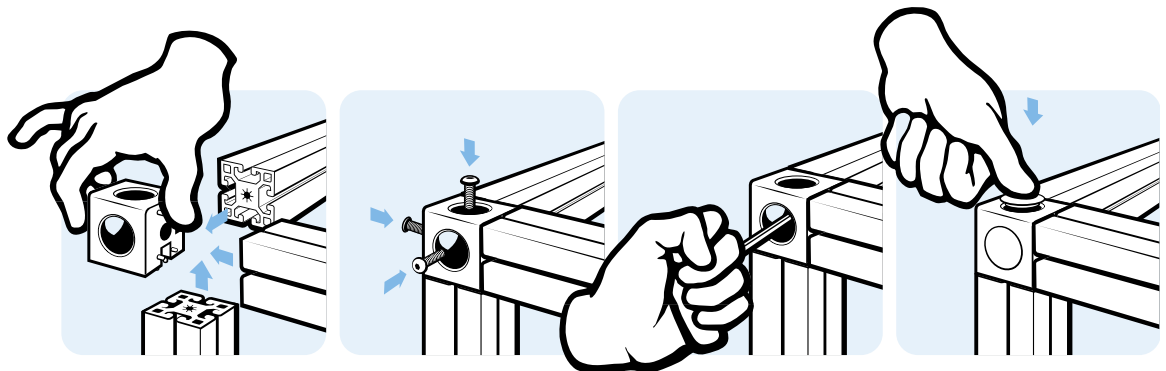



WÜRFELVERBINDER 2D

CUBE CONNECTOR 2D

Ausführung	Aluminiumdruckguss, mit Abdeckkappen	Model	Aluminum die-cast, with cover caps
Beschreibung	zur rechtwinkligen Verbindung von zwei Aluprofilen; mit Abdeckkappen zum Verschließen der Öffnungen	Description	To connect two aluminium profiles at right angles; with cover caps to cover the bores
Material	Würfelverbinder: Aluminiumdruckguss Abdeckkappen: Kunststoff PA Montageset: Stahl	Material	Cube connector: Aluminum die-cast Cover caps: Plastic PA Assembly set: Steel
Montageset 4	2 selbstformende Schrauben S12 × 30 - Torx T50	Assembly Set 4	2 self-forming screws S12 × 30 - Torx T50
Liefereinheit	10 Stück	Pack Quantity	10 pieces

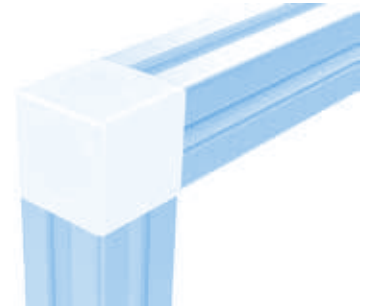
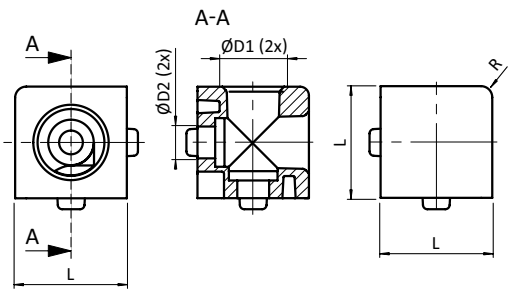

Würfelverbinder 2D <i>Cube Connector 2D</i>	Würfelverbinder 2D <i>Cube Connector 2D</i>	D1 [mm]	D2 [mm]	L [mm]	N	R [mm]	Gewicht [g] <i>Weight [g]</i>	Profil <i>Profile</i>	Teil-Nr. <i>Part #</i>
	blank / schwarz <i>Plain / black</i>	24.0	8.5	40.0	8	4.0	94.5	I	093WW405N08R
	blank / schwarz <i>Plain / black</i>	24.0	12.5	40.0	10	3.0	108.3	B	093WW407N10R
inkl. Montageset 4 <i>With assembly set 4</i>	blank / schwarz <i>Plain / black</i>	24.0	12.5	40.0	10	3.0	108.3	B	093WW407N10RS
	alufarbig / alufarbig <i>Alu color / alu color</i>	24.0	8.5	40.0	8	4.0	94.5	I	093WW405N08
	alufarbig / alufarbig <i>Alu color / alu color</i>	24.0	12.5	40.0	10	3.0	108.3	B	093WW407N10
inkl. Montageset 4 <i>With assembly set 4</i>	alufarbig / alufarbig <i>Alu color / alu color</i>	24.0	12.5	40.0	10	3.0	108.3	B	093WW407N10S

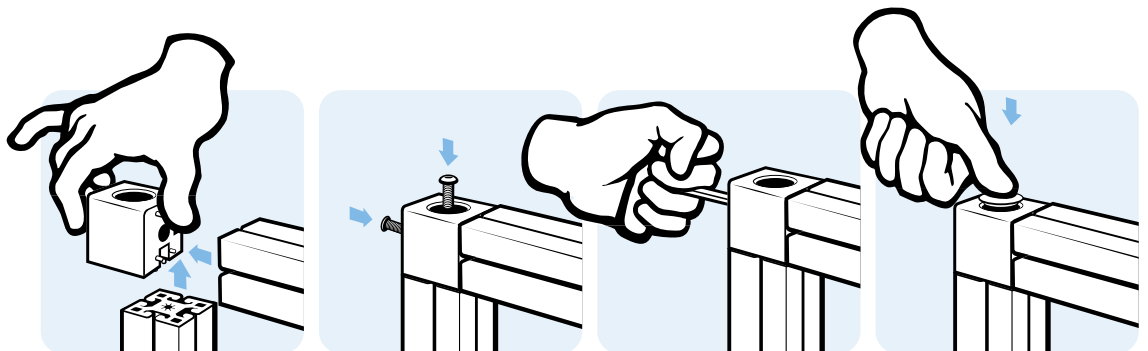

WÜRFELVERBINDER 3D

CUBE CONNECTOR 3D

Ausführung	Aluminiumdruckguss, mit Abdeckkappen	Model	Aluminum die-cast, with cover caps
Beschreibung	zur rechtwinkligen Verbindung von drei Aluminiumprofilen; mit Abdeckkappen zum Verschließen der Öffnungen	Description	To connect three aluminum profiles at right angles; with cover caps to cover the bores
Material	Würfelverbinder: Aluminiumdruckguss Abdeckkappen: Kunststoff PA Montageset: Stahl	Material	Cube connector: Aluminum die-cast Cover caps: Plastic PA Assembly set: Steel
Montageset 4	3 selbstformende Schrauben S12 x 30 - Torx T50	Assembly Set 4	3 self-forming screws S12 x 30 - Torx T50
Liefereinheit	10 Stück	Pack Quantity	10 pieces

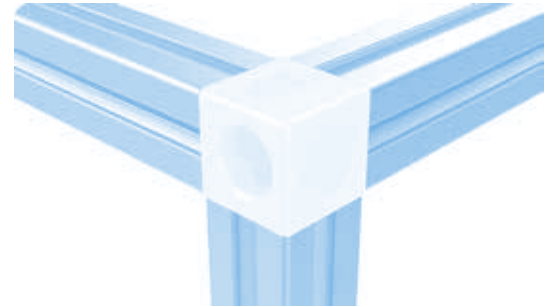
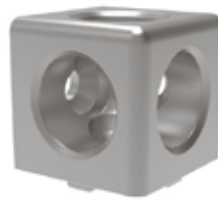
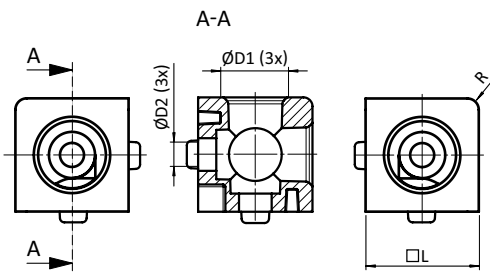

Würfelverbinder 3D <i>Cube Connector 3D</i>	Würfelverbinder 3D <i>Cube Connector 3D</i>	D1 [mm]	D2 [mm]	L [mm]	N	R [mm]	Gewicht [g] <i>Weight [g]</i>	Profil <i>Profile</i>	Teil-Nr. <i>Part #</i>
	blank / schwarz <i>Plain / black</i>	24.0	8.5	40.0	8	4.0	94.5	I	093WW406N08R
	blank / schwarz <i>Plain / black</i>	24.0	12.5	40.0	10	3.0	87.3	B	093WW408N10R
inkl. Montageset 4 <i>With assembly set 4</i>	blank / schwarz <i>Plain / black</i>	24.0	12.5	40.0	10	3.0	87.3	B	093WW408N10RS
	alufarbig / alufarbig <i>Alu color / alu color</i>	24.0	8.5	40.0	8	4.0	94.5	I	093WW406N08
	alufarbig / alufarbig <i>Alu color / alu color</i>	24.0	12.5	40.0	10	3.0	87.3	B	093WW408N10
inkl. Montageset 4 <i>With assembly set 4</i>	alufarbig / alufarbig <i>Alu color / alu color</i>	24.0	12.5	40.0	10	3.0	87.3	B	093WW408N10S

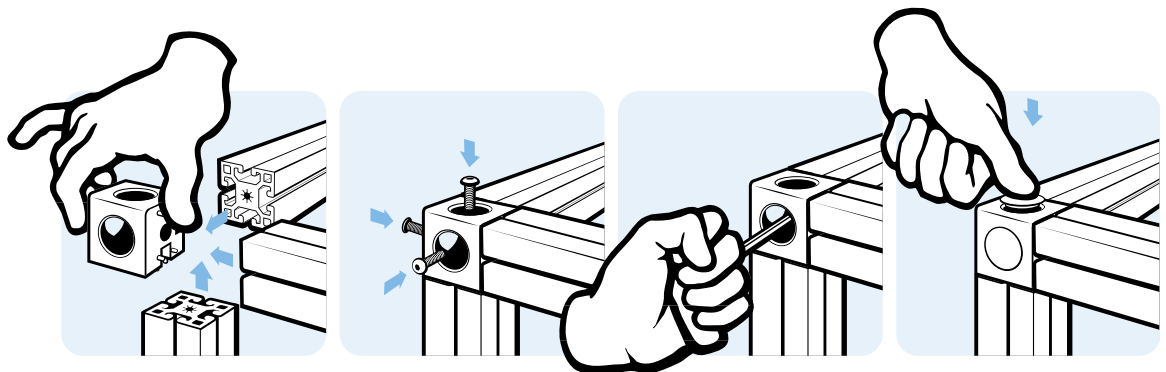



WÜRFELVERBINDER 2D

CUBE CONNECTOR 2D

Ausführung	Aluminiumdruckguss, mit Abdeckkappen	Model	Aluminum die-cast, with cover caps
Beschreibung	zur rechtwinkligen Verbindung von zwei Aluprofilen; mit Abdeckkappen zum Verschließen der Öffnungen	Description	To connect two aluminium profiles at right angles; with cover caps to cover the bores
Material	Würfelverbinder: Aluminiumdruckguss Abdeckkappen: Kunststoff PA Montageset: Stahl	Material	Cube connector: Aluminum die-cast Cover caps: Plastic PA Assembly set: Steel
Montageset 4	2 selbstformende Schrauben S12 × 30 - Torx T50	Assembly Set 4	2 self-forming screws S12 × 30 - Torx T50
Liefereinheit	10 Stück	Pack Quantity	10 pieces

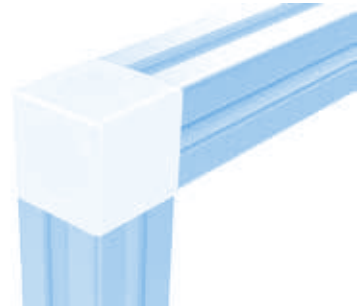
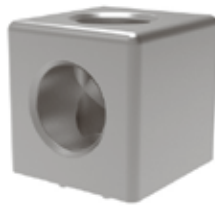
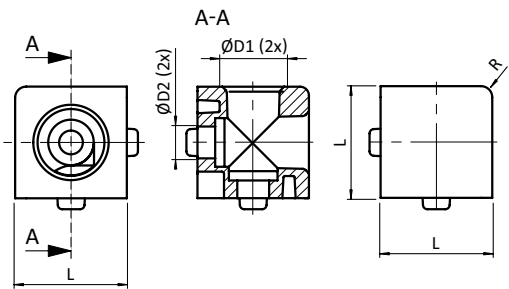

Würfelverbinder 2D <i>Cube Connector 2D</i>	Würfelverbinder 2D <i>Cube Connector 2D</i>	D1 [mm]	D2 [mm]	L [mm]	N	R [mm]	Gewicht [g] <i>Weight [g]</i>	Profil <i>Profile</i>	Teil-Nr. <i>Part #</i>
	blank / schwarz <i>Plain / black</i>	24.0	13.0	45.0	10	3.0	151.5	B	093WW453N10R
inkl. Montageset 4 <i>With assembly set 4</i>	blank / schwarz <i>Plain / black</i>	24.0	13.0	45.0	10	3.0	157.5	B	093WW453N10RS
	alufarbig / alufarbig <i>Alu color / alu color</i>	24.0	13.0	45.0	10	3.0	151.5	B	093WW453N10
inkl. Montageset 4 <i>With assembly set 4</i>	alufarbig / alufarbig <i>Alu color / alu color</i>	24.0	13.0	45.0	10	3.0	157.5	B	093WW453N10S

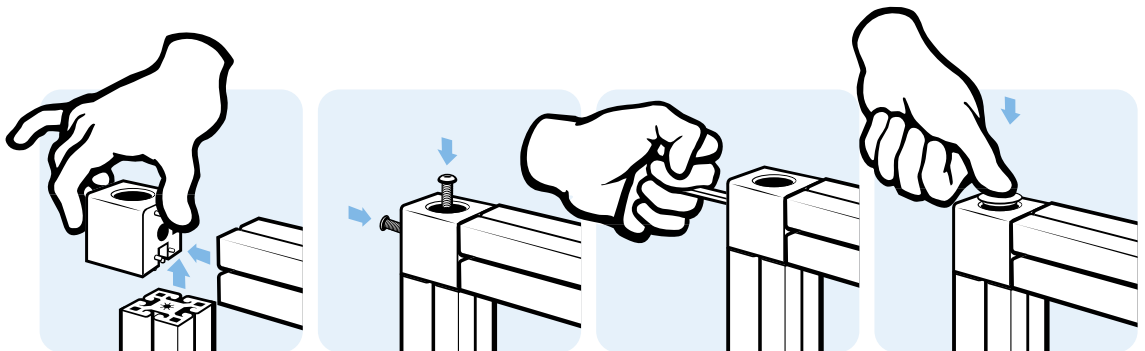

WÜRFELVERBINDER 3D

CUBE CONNECTOR 3D

Ausführung	Aluminiumdruckguss, mit Abdeckkappen	Model	Aluminum die-cast, with cover caps
Beschreibung	zur rechtwinkligen Verbindung von drei Aluminiumprofilen; mit Abdeckkappen zum Verschließen der Öffnungen	Description	To connect three aluminum profiles at right angles; with cover caps to cover the bores
Material	Würfelverbinder: Aluminiumdruckguss Abdeckkappen: Kunststoff PA Montageset: Stahl	Material	Cube connector: Aluminum die-cast Cover caps: Plastic PA Assembly set: Steel
Montageset 4	3 selbstformende Schrauben S12 × 30 - Torx T50	Assembly Set 4	3 self-forming screws S12 × 30 - Torx T50
Liefereinheit	10 Stück	Pack Quantity	10 pieces

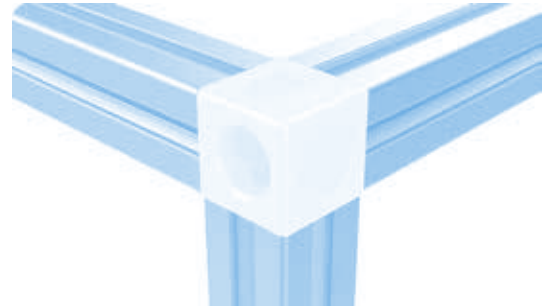
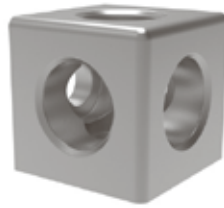
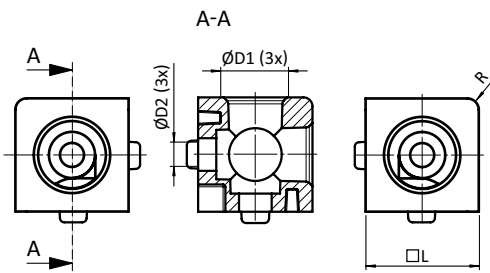

Würfelverbinder 3D Cube Connector 3D	Würfelverbinder 3D Cube Connector 3D	D1 [mm]	D2 [mm]	L [mm]	N	R [mm]	Gewicht [g] Weight [g]	Profil Profile	Teil-Nr. Part #
	blank / schwarz Plain / black	24.0	13.0	45.0	10	3.0	151.5	B	093WW454N10R
inkl. Montageset 4 With assembly set 4	blank / schwarz Plain / black	24.0	13.0	45.0	10	3.0	161.0	B	093WW454N10RS
	alufarbig / alufarbig Alu color / alu color	24.0	13.0	45.0	10	3.0	151.5	B	093WW454N10
inkl. Montageset 4 With assembly set 4	alufarbig / alufarbig Alu color / alu color	24.0	13.0	45.0	10	3.0	161.0	B	093WW454N10S

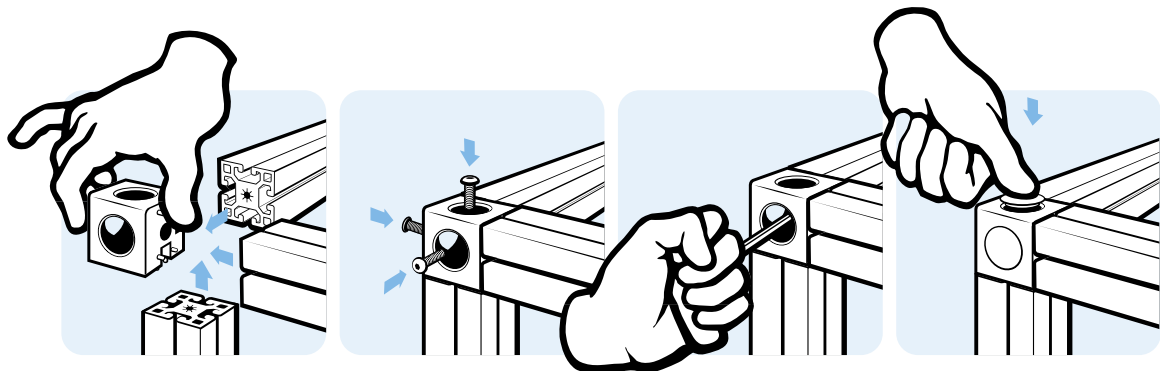



BOLZENVERBINDER

BOLT CONNECTOR

Ausführung	Nut 8	Model	Slot 8
Beschreibung	zur rechtwinkligen, stabilen Verbindung von zwei Aluminiumprofilen; es muss ein 8,2 mm Loch durch die Seite des Profils gebohrt werden	Description	To connect two aluminum profiles at right angles; a 8.2 mm through-hole must be drilled through the side of one profile
Material	Bolzen und Schrauben: Stahl, verzinkt	Material	Bolts and screws: Zinc plated steel
Liefereinheit	10 Stück	Pack Quantity	10 pieces



Bolzenverbinder <i>Bolt Connectors</i>	A [mm]	B [mm]	Gewicht [g] <i>Weight [g]</i>	Profil <i>Profile</i>	Teil-Nr. <i>Part #</i>
	28.0	20.0	21.5	B	099C301
	28.0	18.0	27.0	B	099C303

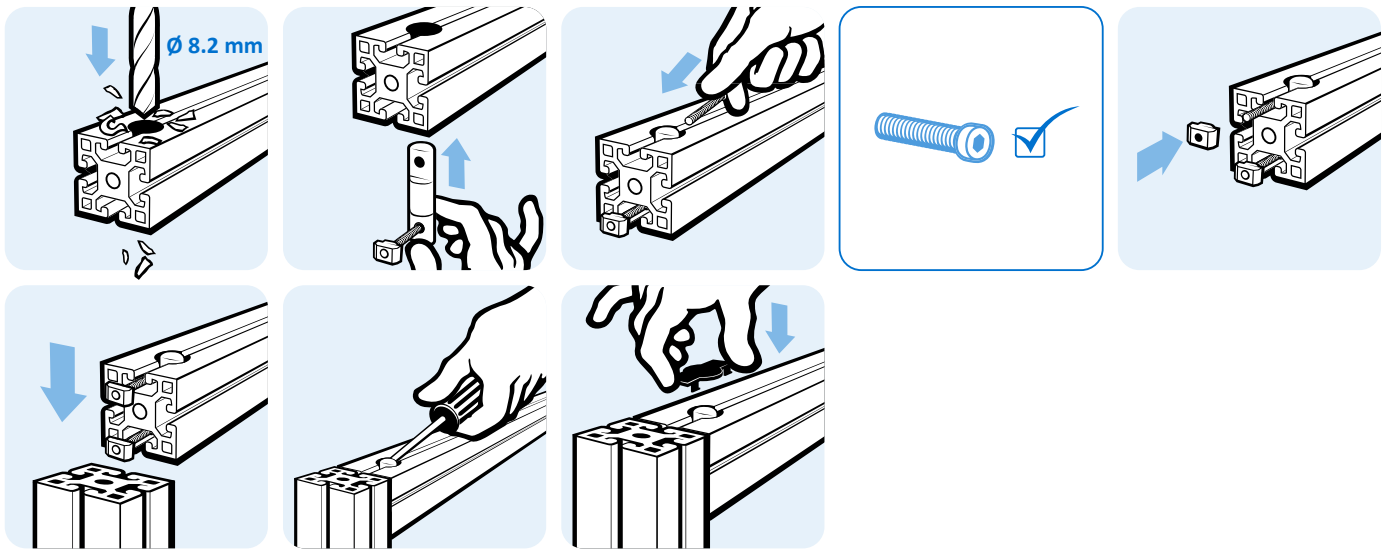

4



BOLZENVERBINDER

BOLT CONNECTOR

Ausführung	Nut 10	Model	Slot 10
Beschreibung	zur rechtwinkligen, stabilen Verbindung von zwei Aluminiumprofilen; es muss ein 17 mm Loch durch die Seite des Profils gebohrt werden	Description	To connect two aluminum profiles at right angles; a 17 mm through-hole must be drilled through the side of one profile
Material	Grundkörper: Stahl, verzinkt Schrauben: Stahl, verzinkt Fixierbolzen: Kunststoff PA, glasfaserverstärkt Schraubenabdeckung: Kunststoff PA, glasfaserverstärkt	Material	Base element: Zinc plated steel Screws: Zinc plated steel Fixing bolts: Plastic PA, glass fiber reinforced Screw cover: Plastic PA, glass fiber reinforced
Liefereinheit	10 Stück	Pack Quantity	10 pieces

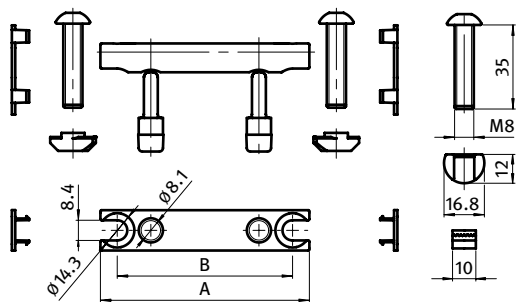

Bolzenverbinder <i>Bolt Connectors</i>	A [mm]	B [mm]	Gewicht [g] <i>Weight [g]</i>	Profil <i>Profile</i>	Teil-Nr. <i>Part #</i>
	37.0	23.0	74.0	B	099C401
	42.0	28.0	78.0	B	099C451
	47.0	33.0	81.0	B	099C501
	57.0	43.0	83.0	B	099C601
	77.0	63.0	121.0	B	099C801
	87.0	73.0	133.5	B	099C901
	97.0	83.0	135.0	B	099C1001

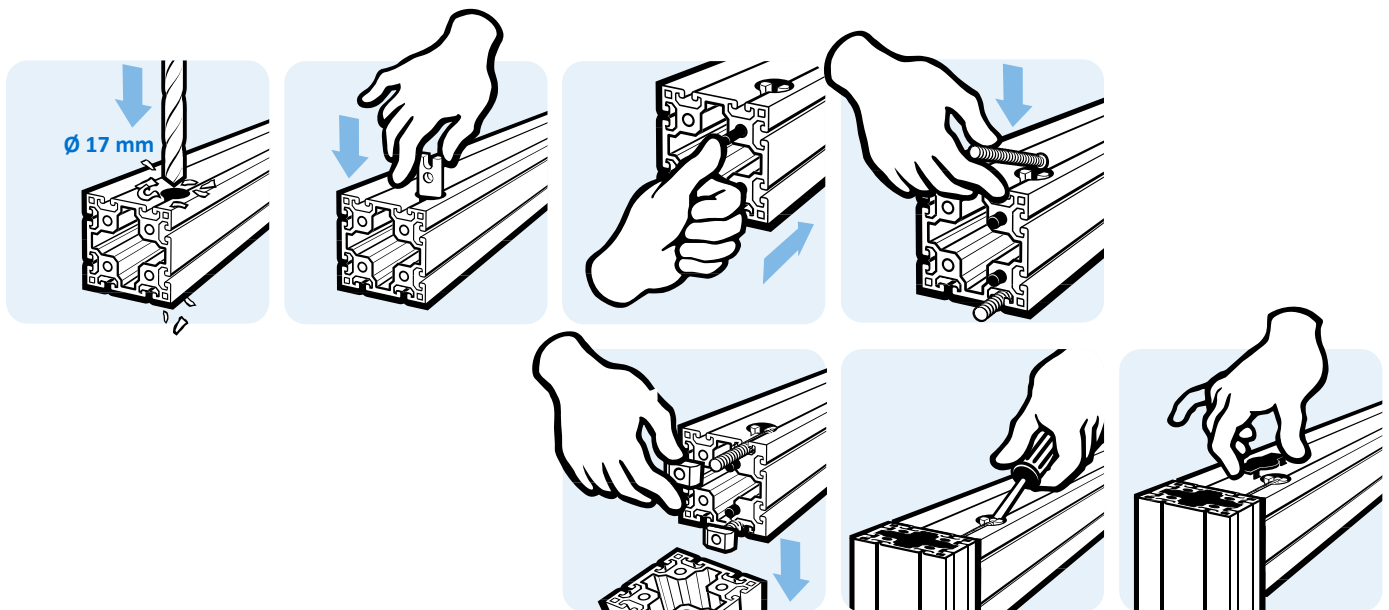

ZENTRALVERBINDER

CENTRAL CONNECTOR

Ausführung Stahl	Model Steel
Beschreibung zur rechtwinkligen Verbindung von zwei Aluminiumprofilen	Description To connect two aluminum profiles at right angles
Material Stahl, verzinkt	Material Zinc plated steel
Liefereinheit 10 Stück	Pack Quantity 10 pieces

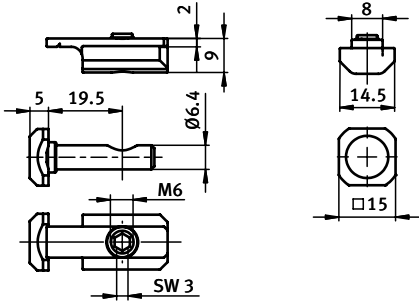

Zentralverbinder Central Connector	ESD	Gewicht [g] Weight [g]	Profil Profile	Teil-Nr. Part #
	elektrostatisch entladend  <i>electrostatically discharging</i>	30.0	B	099ZV0830

4



ZENTRALVERBINDER

CENTRAL CONNECTOR

Ausführung	Edelstahl	Model	Stainless steel
Beschreibung	zur rechtwinkligen Verbindung von zwei Aluminiumprofilen; zur Montage muss ein Loch in eines der Profile gebohrt werden	Description	To connect two aluminum profiles at right angles; a hole must be drilled through one of the profiles to provide access to the tightening screw
Material	Edelstahl	Material	Stainless steel
Liefereinheit	10 Stück	Pack Quantity	10 pieces

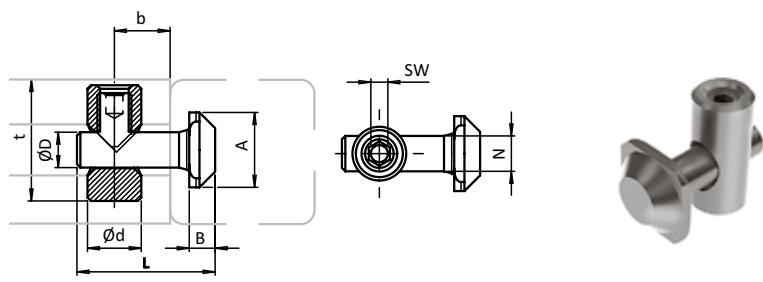

Winkel Angle	A [mm]	B [mm]	b [mm]	Ød [mm]	D [mm]	L [mm]	N [mm]	SW [mm]	T [mm]	Gewicht [g] Weight [g]	Profil Profile	Teil-Nr. Part #
0° / 90°	11.0	3.8	10.0	8.0	5.2	20.3	6.0	2.5		9.5	B	099B060805

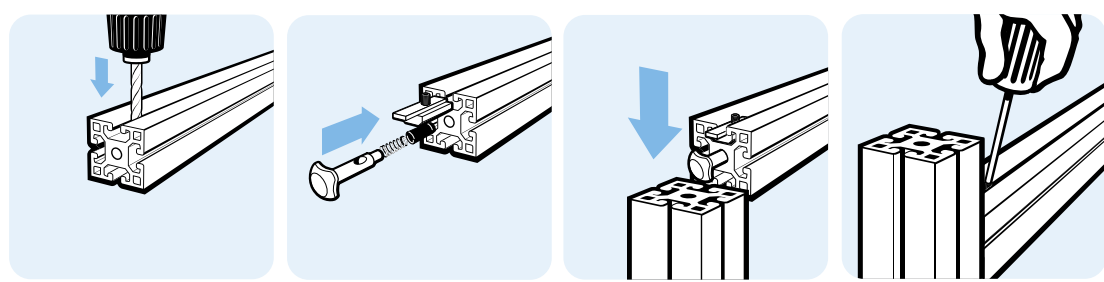



ZENTRALVERBINDER

CENTRAL CONNECTOR

Ausführung	Buchse 15	Model	Bush 15
Beschreibung	zur rechtwinkligen Verbindung von zwei Aluminiumprofilen; zur Montage muss ein Loch in eines der Profile gebohrt werden	Description	To connect two aluminum profiles at right angles; a hole must be drilled through one of the profiles to provide access to the tightening screw
Material	Stahl, verzinkt	Material	Zinc plated steel
Liefereinheit	10 Stück	Pack Quantity	10 pieces

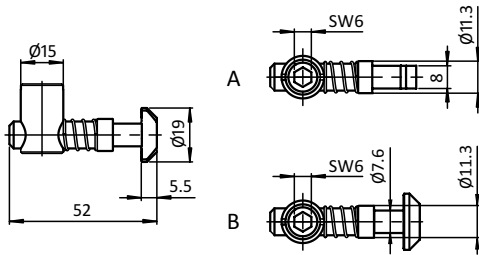

Zentralverbinder
Central Connectors

Gewicht [g]
Weight [g]

Teil-Nr.
Part #

(A) Hammer senkrecht zur Buchse (A) Hammer vertically to bush	49.0	099B081511S
(A) Hammer waagrecht zur Buchse (A) Hammer horizontally to bush	49.0	099B081511W
(B) Hammer senkrecht / waagrecht zur Buchse (B) Hammer vertically / horizontally to bush	50.0	099B081511



ZENTRALVERBINDER

CENTRAL CONNECTOR

<p>Ausführung Stahl, Profil 40, Nut 8</p> <p>Beschreibung zur rechtwinkligen Verbindung von zwei Aluminiumprofilen; zur Montage muss ein 28 mm tiefes Sackloch mit $\varnothing 14,2$ mm seitlich und ein 20 mm tiefes Sackloch mit $\varnothing 8,2$ mm stirnseitig gebohrt werden; inklusive Abdeckkappe</p> <p>Material Verbinder: Stahl Klammer: Edelstahl Abdeckkappen: Kunststoff PP</p> <p>Farbe Abdeckkappe: grau \approx RAL 7042</p> <p>Liefereinheit 10 Stück</p> <p>Hinweis passende Radiendichtung siehe Seite 522; Beim Verbau mit Radiendichtung sollte das Abstandsmaß der Bohrung um die Dicke der Radiendichtung verringert werden</p>	<p>Model Steel, profile 40, slot 8</p> <p>Description To connect two aluminum profiles at right angles; before the application a 28 mm deep blind hole with $\varnothing 14,2$ mm lateral and a 20 mm deep blind hole with $\varnothing 9,0$ mm frontal must be drilled; with cover cap</p> <p>Material Connector: Steel Clamp: Stainless steel Cover caps: Plastic PP</p> <p>Color Cover cap: gray \approx RAL 7042</p> <p>Pack Quantity 10 pieces</p> <p>Tip Compatible radius seal see page 522; If used with the radius seal, the distance between the bore hole should be reduced by the thickness of the radius seal</p>
---	---

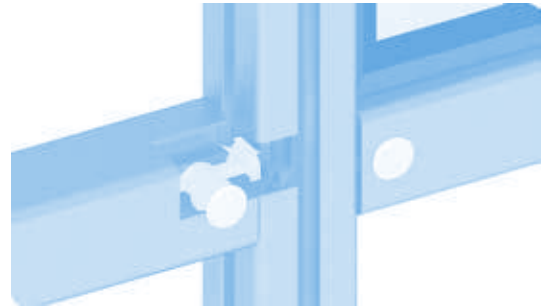
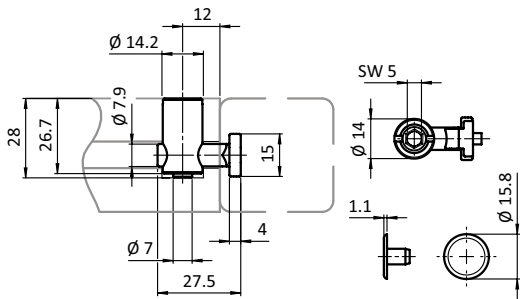

Zentralverbinder Central Connectors	N	Gewicht [g] Weight [g]	Profil Profile	Teil-Nr. Part #
	8	42.8	I	099B081408



ZENTRALVERBINDER

CENTRAL CONNECTOR

Ausführung Stahl	Model Steel
Beschreibung zur rechtwinkligen Verbindung von zwei Aluminiumprofilen; zur Montage muss ein Sack- oder Durchgangsloch in eines der Profile gebohrt werden	Description To connect two aluminum profiles at right angles; a blind or through hole must be drilled through one of the profiles to provide access to the tightening screw
Material Stahl	Material Steel
Liefereinheit 10 Stück	Pack Quantity 10 pieces
Hinweis * (1) = Profil 40; (2) = Profil 45; (3) = Profil 50; (4) = Profil 60	Tip * (1) = profile 40; (2) = profile 45; (3) = profile 50; (4) = profile 60

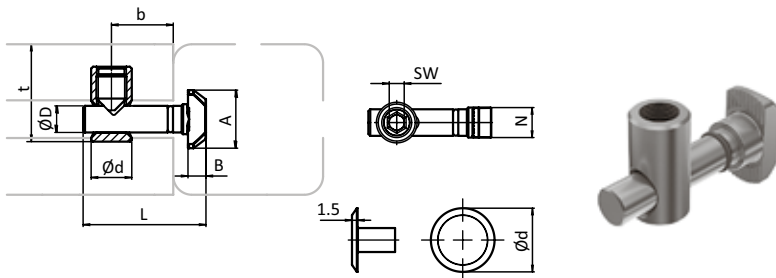

Winkel Angle	A [mm]	B [mm]	D [mm]	L [mm]	N	SW [mm]	Gewicht [g] Weight [g]	Profil Profile	Teil-Nr. Part #
0°	15.5	4.8	7.1	33.0	8	4	21.0	B	099B08110700
90°	15.5	4.8	7.1	33.0	8	4	20.0	B	099B08110790
0°	19.6	5.5	7.1	40.0	8 / 10	4	26.0	B	099B08110700S01
90°	19.6	5.5	7.1	40.0	8 / 10	4	26.0	B	099B08110790S01
0°	19.6	5.5	9.8	45.5	10	6	56.0	B	099B10171000
90°	19.6	5.5	9.8	45.5	10	6	56.0	B	099B10171090
Abdeckkappe Cover cap					10 *(1) *(2)		0.6	B	091107
					10 *(3)		0.6	B	091108

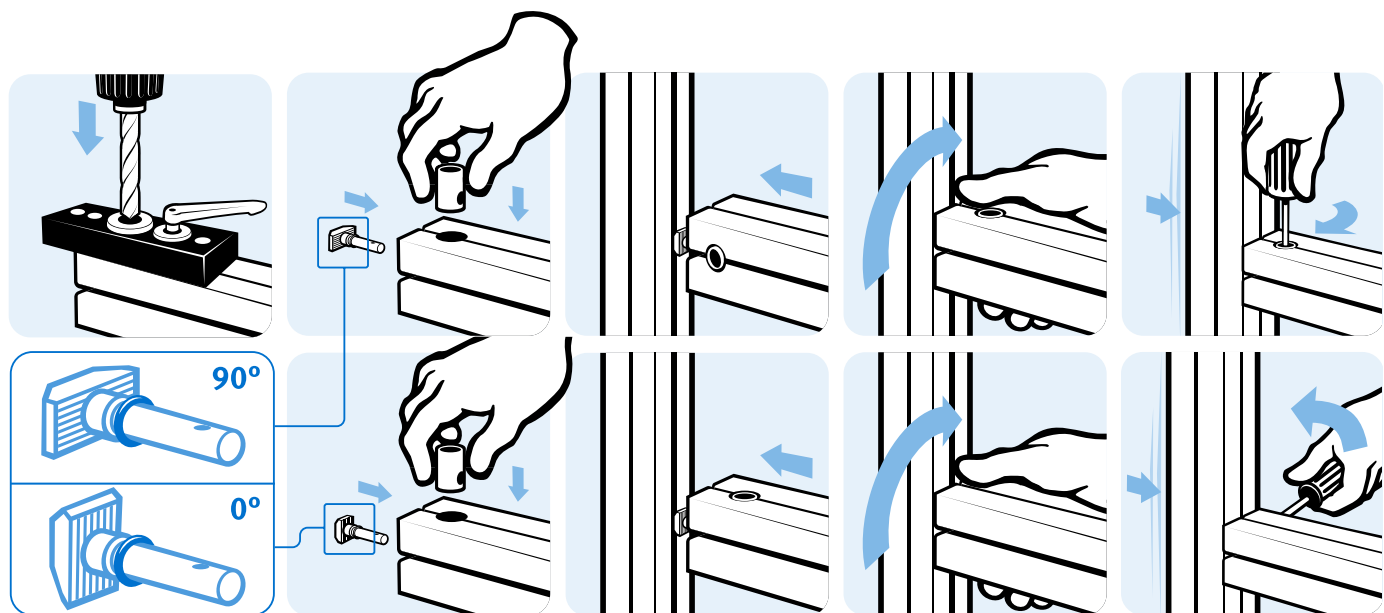



ZENTRALVERBINDER

CENTRAL CONNECTOR

<p>Ausführung Stahl</p> <p>Beschreibung zur rechtwinkligen Verbindung von zwei Aluminiumprofilen; zur Montage muss ein Durchgangsloch in eines der Profile gebohrt werden, die Nutflanken werden dabei nicht berührt; die Hülse schließt an beiden Enden eben mit dem Nutboden ab, somit bleiben beide Nuten frei; die Nut kann mit einem Abdeckprofil vollständig verdeckt werden</p> <p>Material Stahl, verzinkt</p> <p>Liefereinheit 10 Stück</p>	<p>Model Steel</p> <p>Description To connect two aluminum profiles at right angles; a through hole must be drilled into one of the profiles to provide access to the tightening screw, the slot walls are not affected by this; the bush flush fits with the slot base, thus leaving both slots free to use; the slot can be completely covered with a cover profile</p> <p>Material Zinc plated steel</p> <p>Pack Quantity 10 pieces</p>
--	---



Winkel Angle	A [mm]	B [mm]	b [mm]	Ød [mm]	D [mm]	L [mm]	N	SW [mm]	Gewicht [g] Weight [g]	Profil Profile	Teil-Nr. Part #
0°	19.4	5.3	22.5	9.8	6.8	45.6	10	3	29.0	B	099B10101000
90°	19.4	5.3	22.5	9.8	6.8	45.6	10	3	29.0	B	099B10101090



SET ANSCHRAUBVERBINDER

SET SCREW-ON CONNECTOR

Ausführung	Stahl	Model	Steel
Beschreibung	zur rechtwinkligen Verbindung von zwei Aluminiumprofilen	Description	To connect two aluminum profiles at right angles
Material	Anschraubverbinder: Stahl Schraube: Stahl Schneidhülse: Stahl	Material	Screw-on connector: Steel Screw: Steel Cutting bush: Steel
Set 1	1 Anschraubverbinder, vormontiert mit zwei Druckschrauben, 1 selbstfurchende Zentralschraube S7	Set 1	1 screw-on connector, pre-assembled with two pressure screws, 1 self-cutting central screw S7
Set 2	1 Anschraubverbinder, vormontiert mit zwei Druckschrauben, 1 selbstfurchende Zentralschraube S8 (M8 kompatibel)	Set 2	1 screw-on connector, pre-assembled with two pressure screws, 1 self-cutting central screw (compatible with M8)
Liefereinheit	10 Stück	Pack Quantity	10 pieces

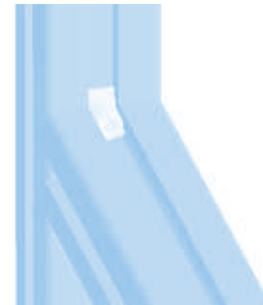
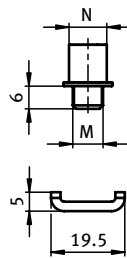
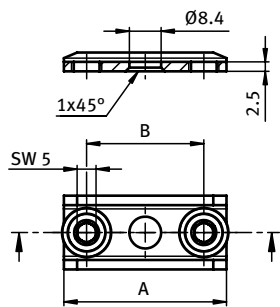

Set Anschraubverbinder Set Screw-on Connector	A [mm]	B [mm]	M	N	Gewicht [g] Weight [g]	Profil Profile	Teil-Nr. Part #
Set 1	38.0	28.0	M8	8	30.0	I	099AV0840S02
Set 2	43.0	31.0	M8	10	40.0		099AV1045S02
Set 3	43.0	31.0	M8	10	45.0	B	099AV1045S01
					31.5		09308802

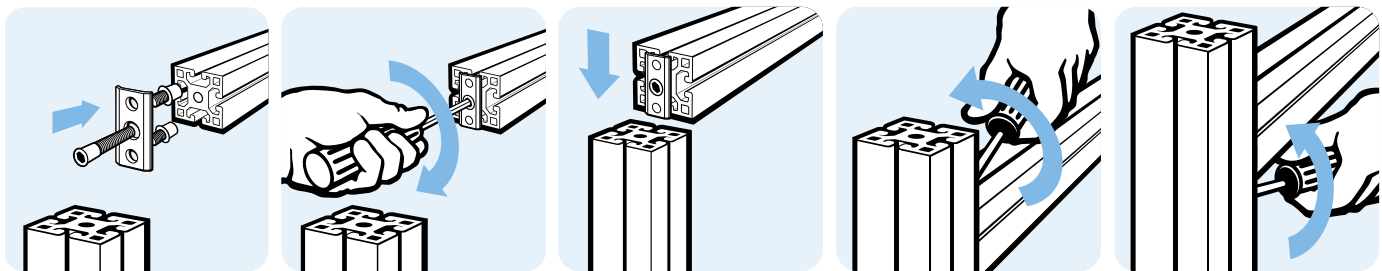

SELBSTFORMENDE SENKKOPFSCHRAUBE

SELF-FORMING COUNTERSUNK SCREW

Ausführung	mit Innensechskant	Model	With hexagon socket
Beschreibung	für alle Befestigungen an der Stirnseite des Profils; lösbar und wiederverwendbar; schafft eine festigkeitsoptimierte Gewindeform	Description	For all mounting applications to the front of the aluminum profile; detachable and reusable; designed for optimized fastening strength
Material	Stahl	Material	Steel
Liefereinheit	100 Stück	Pack Quantity	100 pieces
Hinweis	* passende Abdeckkappe ZN anschraubbar siehe Seite 740	Tip	* Compatible screw-on cover cap ZN see page 740

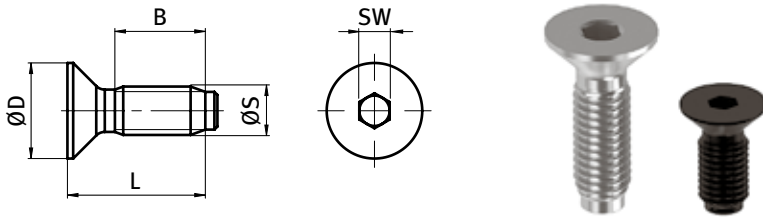

Selbstformende Senkkopfschraube <i>Self-forming Countersunk Screw</i>	B [mm]	D [mm]	SW	Größe S × L [mm] <i>Size S × L [mm]</i>	Gewicht [g] <i>Weight [g]</i>	Profil <i>Profile</i>	Teil-Nr. <i>Part #</i>
	11.0	12.0	4	S7 × 16	6.0	I	*093S0716C
kompatibel mit metrischen Gewinden <i>Compatible with metric threads</i>	20.0	15.8	5	S8 × 25	12.0	B	093S0825C

SELBSTFORMENDE HALBRUNDSCHRAUBE

SELF FORMING BUTTON HEAD SCREW

Ausführung	Nut 8	Model	Slot 8
Beschreibung	zur stirnseitigen Befestigung von Eckwinkeln, Winkeln, Verdrehsicherungen oder anderen Komponenten im Kernloch von Aluminiumprofilen; für die Montage ist kein Gewindeschneiden erforderlich	Description	To fix connection angles, angles, turn-locks and other components to the core hole of the aluminum profile; no thread cutting is needed to fix the screw
Material	Stahl, verzinkt	Material	Zinc plated steel
Liefereinheit	100 Stück	Pack Quantity	100 pieces

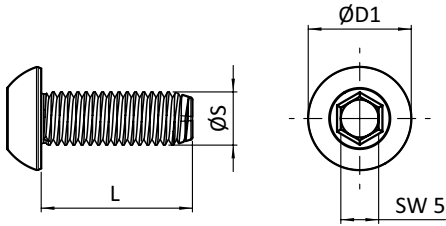





Selbstformende Halbrundschrabe <i>Self Forming Button Head Screw</i>	D1 [mm]	SW [mm]	Größe S × L <i>Size S × L</i>	Gewicht [g] <i>Weight [g]</i>	Profil <i>Profile</i>	Teil-Nr. <i>Part #</i>
	13.7	5	S7 × 20	8.2	I	093S0720M

SELBSTFORMENDE SCHRAUBE

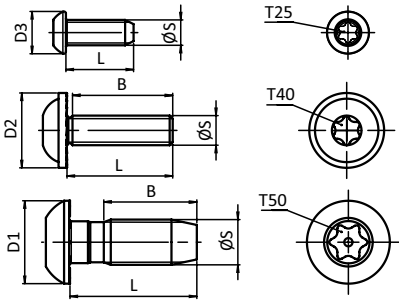
SELF FORMING SCREW

Ausführung mit Torx	Model With Torx
Beschreibung zur Verbindung von zwei Aluminiumprofilen; für die Montage ist kein Gewindeschneiden erforderlich; durch die spezielle Form des Schraubenkopfes und des selbstformenden Gewindes entsteht eine leitfähige Verbindung zwischen den Profilen	Description To connect two aluminum profiles; no thread cutter is necessary to fix the screw; because of the special form of the head of the screw and the self-forming thread, a conductive connection of two aluminum profiles is achieved
Material Stahl, verzinkt	Material Zinc plated steel
Liefereinheit 100 Stück	Pack Quantity 100 pieces



Selbstschneidende Schraube Self Forming Screw	B [mm]	D1 [mm]	D2 [mm]	D3 [mm]	Extras	Größe S × L [mm] Size S × L [mm]	Montage Assembly	Gewicht [g] Weight [g]	Profil Profile	Teil-Nr. Part #
	14.0			10.0		S6 × 16	Torx T25	4.0	B	093S0616T
	23.0		17.5			S7 × 25	Torx T40	11.0	I	093S0725T
	23.0		16.0			S8 × 25	Torx T40	12.0	B	093S0825T
	22.0	19.0				S12 × 30	Torx T50	25.2	B	093S1230T

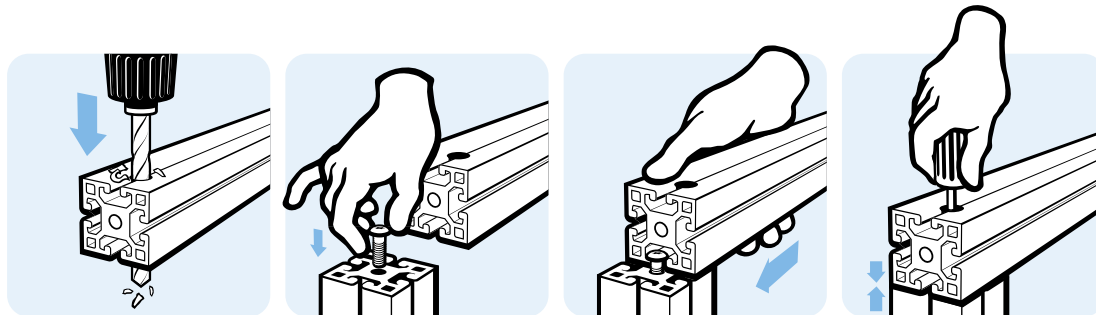



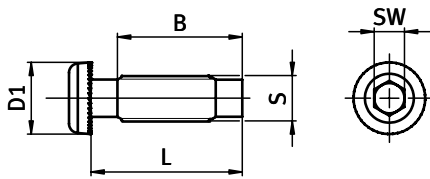

SELBSTFURCHENDE SCHRAUBE

SELF-TAPPING SCREW

Ausführung	mit Innensechskant	Model	With hexagon socket
Beschreibung	zur Verbindung von zwei Aluminiumprofilen; für die Montage ist kein Gewindeschneiden erforderlich; durch die spezielle Form des Schraubenkopfes und des selbstformenden Gewindes entsteht eine leitfähige Verbindung zwischen den Profilen	Description	To connect two aluminum profiles; no thread cutter is necessary to fix the screw; because of the special form of the head of the screw and the self-forming thread, a conductive connection of two aluminum profiles is achieved
Material	Stahl, verzinkt	Material	Zinc plated steel
Liefereinheit	100 Stück	Pack Quantity	100 pieces



Selbstfurchende Schraube Self-tapping Screw	B [mm]	D1 [mm]	SW	Extras	Größe S × L Size S × L	Gewicht [g] Weight [g]	Profil Profile	Teil-Nr. Part #
	10.8	8.5	3		S5 × 16	1.0	I	093SF0516
	19.5	13.8	5		S7 × 25	11.0	I	093SF0725
	34.5	13.8	5		S7 × 40	15.0	I	093SF0740
	26.0	19.0	8		S12 × 40	31.0	B	093SF1240

VERBINDERSCHRAUBE

CONNECTING SCREW

Ausführung	Stahl	Model	Steel
Beschreibung	zur Verbindung von zwei Aluminiumprofilen	Description	To connect two aluminum profiles
Material	Stahl, verzinkt	Material	Zinc plated steel
Liefereinheit	100 Stück	Pack Quantity	100 pieces

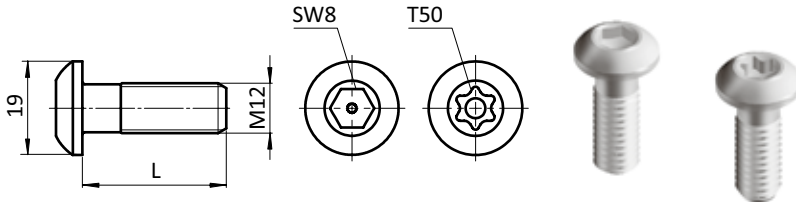

Verbinderschraube <i>Connecting Screw</i>	Größe M × L [mm] <i>Size M × L [mm]</i>	Montage <i>Assembly</i>	Gewicht [g] <i>Weight [g]</i>	Profil <i>Profile</i>	Teil-Nr. <i>Part #</i>
	M12 × 30	Innensechskant SW8 <i>Hexagon socket SW8</i>	28.4	B	093M1230
	M12 × 30	Torx T50	28.2	B	093M1230T



PLATTENVERBINDER

PLATE CONNECTOR

Ausführung	Aluminiumdruckguss	Model	Aluminum die-cast
Beschreibung	zum Herstellen einer T-Verbindung zwischen zwei Aluminiumprofilen	Description	To tee connect two aluminum profiles
Material	Plattenverbinder: Aluminiumdruckguss Montageset: Stahl	Material	Plate connector: Aluminum die-cast Assembly set: Steel
Oberfläche	Plattenverbinder: blank / alufarbig lackiert Montageset: verzinkt	Surface	Plate connector: Plain / alu color Assembly set: Zinc plated
Montageset 1	1 Schraube DIN 7984 - M8 × 30, 2 Schrauben DIN 7984 - M5 × 16, 2 Hammermuttern - Nut 8 - M5	Assembly Set 1	1 screw DIN 7984 - M8 × 30, 2 screws DIN 7984 - M5 × 16, 2 hammer nuts - slot 8 - M5
Montageset 2	1 selbstformende Schraube S12 × 30 Torx T50, 2 Schrauben DIN 7984 - M6 × 20, 2 Hammermuttern - Nut 10 - M6	Assembly Set 2	1 self forming screw S12 × 30 Torx T50, 2 screws DIN 7984 - M6 × 20, 2 hammer nuts - slot 10 - M6
Liefereinheit	10 Stück	Pack Quantity	10 pieces
Extras	weitere Oberflächen auf Anfrage	Specials	Other surfaces on request

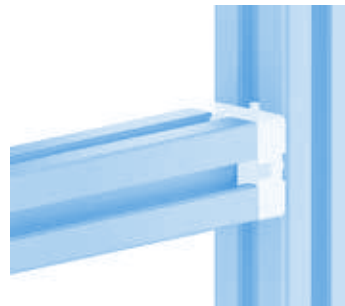
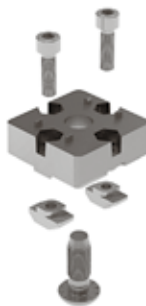
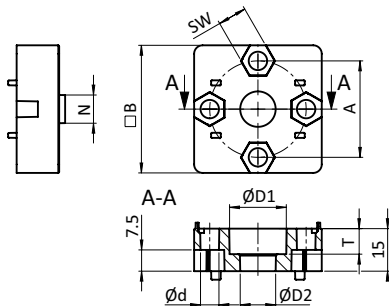

Plattenverbinder <i>Plate Connector</i>	A [mm]	B [mm]	D1 [mm]	D2 [mm]	N	SW [mm]	T [mm]	Gewicht [g] <i>Weight [g]</i>	Profil <i>Profile</i>	Teil-Nr. <i>Part #</i>
blank <i>Plain</i>	21.0	30	13.6	8.5	8	8	6.0	20.0		099EA30300808R
	29.6	40	20.0	12.5	10	10	6.5	39.0		099EA40401012R
	34.0	45	20.0	12.5	10	10	9.0	50.0		099EA45451012R
blank, inkl. Montageset 1 <i>Plain, incl. assembly set 1</i>	21.0	30	13.6	8.5	8	8	6.0	52.0	B	099EA30300808RS01
blank, inkl. Montageset 2 <i>Plain, incl. assembly set 2</i>	29.6	40	20.0	12.5	10	10	6.5	89.0	B	099EA40401012RS01
	34.0	45	20.0	12.5	10	10	9.0	100.0	B	099EA45451012RS01
alufarbig <i>Alu color</i>	21.0	30	13.6	8.5	8	8	6.0	20.0		099EA30300808A
	29.6	40	20.0	12.5	10	10	6.5	39.0		099EA40401012A
	34.0	45	20.0	12.5	10	10	9.0	50.0		099EA45451012A
alufarbig, inkl. Montageset 1 <i>Alu color, incl. assembly set 1</i>	21.0	30	13.6	8.5	8	8	6.0	52.0	B	099EA30300808AS01
alufarbig, inkl. Montageset 2 <i>Alu color, incl. assembly set 2</i>	29.6	40	20.0	12.5	10	10	6.5	89.0	B	099EA40401012AS01
	34.0	45	20.0	12.5	10	10	9.0	100.0	B	099EA45451012AS01

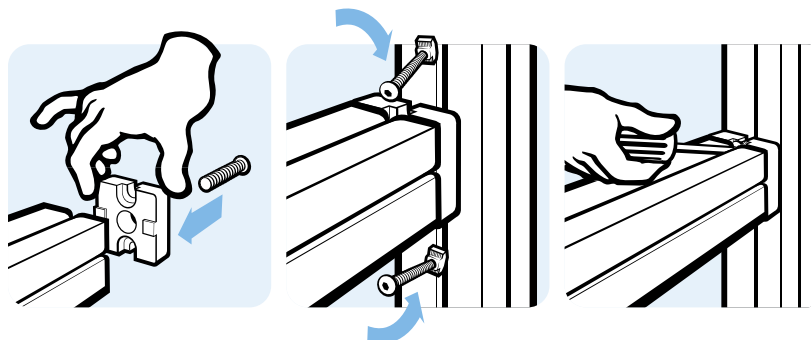



PLATTENVERBINDER 45

PLATE CONNECTOR 45

Ausführung	Zinkdruckguss, Nut 10	Model	Zinc die-cast, slot 10
Beschreibung	zum Herstellen einer T-Verbindung zwischen zwei Aluminiumprofilen	Description	To tee connect two aluminum profiles
Material	Zinkdruckguss	Material	Zinc die-cast
Befestigung	für Schrauben: 1 × M12 × 30, 2 × M6 × 18 und 2 Nutensteine oder Hammermuttern	Fastening	For screws: 1 × M12 × 30, 2 × M6 × 18 and 2 T-slot nuts or hammer nuts
Liefereinheit	10 Stück	Pack Quantity	10 pieces

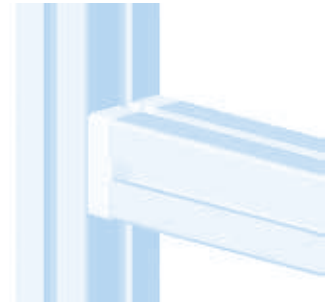
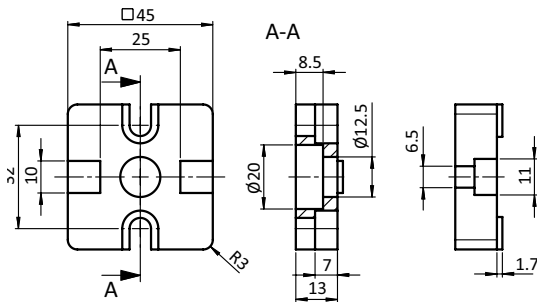

Plattenverbinder <i>Plate Connector</i>		Gewicht [g] <i>Weight [g]</i>	Teil-Nr. <i>Part #</i>
	alufarbig <i>Alu color</i>	88.6	099E45451012A
	blank <i>Plain</i>	88.6	099E45451012R

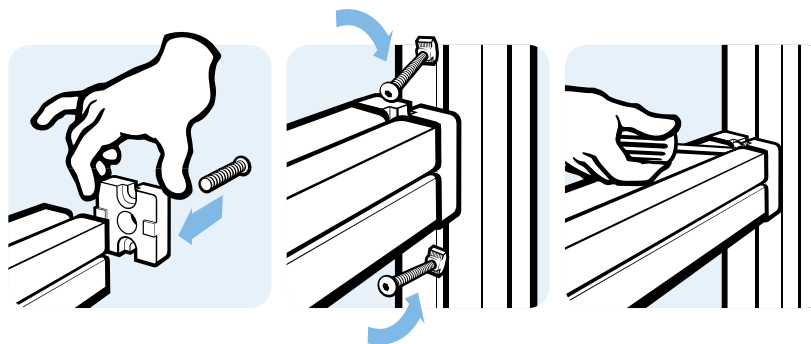



PLATTENVERBINDER 40

PLATE CONNECTOR 40

Ausführung	mit Klemmflügel für Nut 8	Model	With plastic clamp for slot 8
Beschreibung	zum Herstellen einer T-Verbindung zwischen zwei Aluminiumprofilen	Description	To tee connect two aluminum profiles
Material	Kunststoff PA, glasfaserverstärkt	Material	Plastic PA, glass fiber reinforced
Farbe	schwarz	Color	Black
Set	1 Plattenverbinder, 1 Keil, Stahl verzinkt, 2 Zylinderkopfschrauben, M4 × 14, Stahl verzinkt, 1 selbstformende Schraube, SF7 × 25 mit Innensechskant, Stahl verzinkt	Set	1 plate connector, 1 wedge, zinc plated steel, 2 cylinder head screws, M4 × 14, zinc plated steel, 1 self tapping screw, SF7 × 25 with hexagon socket, zinc plated steel
Liefereinheit	10 Stück	Pack Quantity	10 pieces
Extras	weitere Oberflächen, weitere Farben auf Anfrage	Specials	Other surfaces, other colors on request

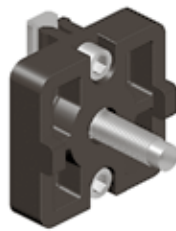
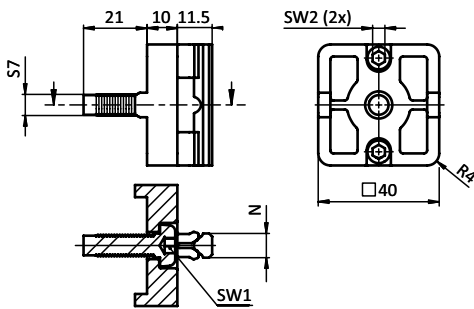

Set Plattenverbinder <i>Plate Connector Set</i>	SW1	SW2	Nut 8 <i>Slot 8</i>	Gewicht [g] <i>Weight [g]</i>	Profil <i>Profile</i>	Teil-Nr. <i>Part #</i>
40	5	4	8	39.0	I	099E40400808K

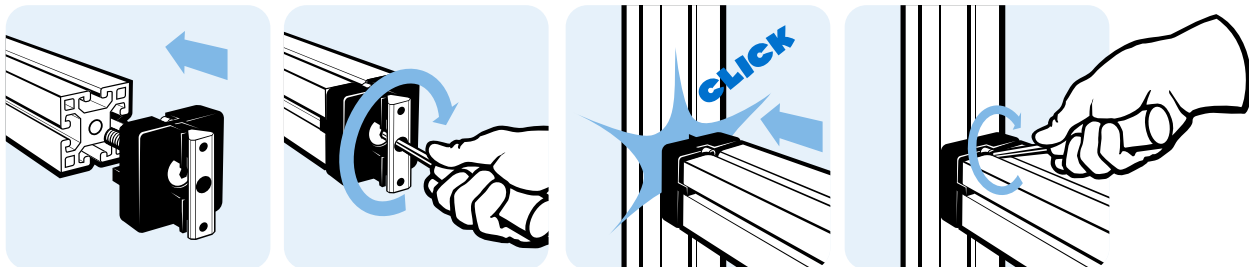



PLATTENVERBINDER 40 (SET)

PLATE CONNECTOR 40 (SET)

Ausführung	Zinkdruckguss, Nut 8	Model	Zinc die-cast, slot 8
Beschreibung	zum Herstellen einer T-Verbindung zwischen zwei Aluminiumprofilen	Description	To tee connect two aluminum profiles
Material	Plattenverbinder: Zinkdruckguss Montageset: Stahl	Material	Plate Connector: Zinc die-cast Assembly set: Steel
Montageset 1	1 selbstfurchende Schraube SF7 × 25, 1 Doppelnutstein - Nut 8 - M8, 2 Schaftschrauben M8	Assembly Set 1	2 self-tapping screws SF7 × 25, 1 double T-slot nut - Nut 8 - M8, 2 shaft screws M8
Montageset 2	2 selbstfurchende Schrauben SF7 × 25, 1 Doppelnutstein - Nut 8 - M8, 2 Schaftschrauben M8	Assembly Set 2	2 self-tapping screws SF7 × 25, 1 double T-slot nut - Nut 8 - M8, 2 shaft screws M8
Montageset 3	2 selbstfurchende Schrauben SF7 × 25, 2 Doppelnutstein - Nut 8 - M8, 4 Schaftschrauben M8	Assembly Set 3	2 self-tapping screws SF7 × 25, 2 double T-slot nut - Nut 8 - M8, 4 shaft screws M8
Liefereinheit	10 Stück	Pack Quantity	10 pieces



Plattenverbinder <i>Plate Connector</i>	A × B [mm]	N	Gewicht [g] <i>Weight [g]</i>	Profil <i>Profile</i>	Teil-Nr. <i>Part #</i>
blank, inkl. Montageset 1 <i>Plain, incl. assembly set 1</i>	40 × 40	8	135.0	I	099E40400808RS01
blank, inkl. Montageset 2 <i>Plain, incl. assembly set 2</i>	40 × 80	8	242.0	I	099E40800808RS01
blank, inkl. Montageset 3 <i>Plain, incl. assembly set 3</i>	40 × 80	8	266.0	I	099E40800808RS02
alufarbig, inkl. Montageset 1 <i>Alu color, incl. assembly set 1</i>	40 × 40	8	135.0	I	099E40400808AS01
alufarbig, inkl. Montageset 2 <i>Alu color, incl. assembly set 2</i>	40 × 80	8	242.0	I	099E40800808AS01
alufarbig, inkl. Montageset 3 <i>Alu color, incl. assembly set 3</i>	40 × 80	8	266.0	I	099E40800808AS02



UNIVERBINDER

UNIVERSAL CONNECTOR

Ausführung	Zinkdruckguss	Model	Zinc die-cast
Beschreibung	zur Verbindung von zwei Aluminiumprofilen	Description	To connect two aluminum profiles
Material	Zinkdruckguss	Material	Zinc die-cast
Montageset 1	1 Nutenstein - Nut 5 - M4, 1 Schraube DIN 912 - M4 x 14	Assembly Set 1	1 T-slot nut - slot 5 - M4, 1 screw DIN 912 - M4 x 14
Montageset 2	1 Nutenstein - Nut 6 - M6, 1 Schraube ISO 7380 - M6 x 22	Assembly Set 2	1 T-slot nut - slot 6 - M6, 1 screw ISO 7380 - M6 x 22
Montageset 3	1 Nutenstein - Nut 8 - M8, 1 Schraube ISO 7380 - M8 x 30	Assembly Set 3	1 T-slot nut - slot 8 - M8, 1 screw ISO 7380 - M8 x 30
Liefereinheit	100 Stück	Pack Quantity	100 pieces
Liefereinheit Set	10 Stück	Pack Quantity Set	10 pieces

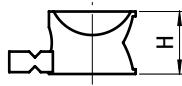
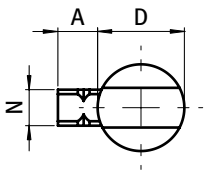

Univerbinder <i>Universal Connector</i>	A [mm]	D [mm]	H [mm]	N	für Schraube <i>for Screw</i>	Profilbreite <i>Profile Width</i>	Gewicht [g] <i>Weight [g]</i>	Profil <i>Profile</i>	Teil-Nr. <i>Part #</i>
	5.4	11.8	8.5	5	M4	20	3.4		099A0520
	9.3	15.7	12.5	6	M6	30	9.5		099A0630
	11.5	19.7	11.0	8	M6	30	13.0		099A0830
	13.7	19.7	16.0	8	M8	40	19.5		099A0840
inkl. Montageset 1 <i>With assembly set 1</i>	5.4	11.8	8.5	5	inkl. <i>incl.</i>	20	7.3	I	099A0520S01
inkl. Montageset 2 <i>With assembly set 2</i>	9.3	15.7	12.5	6	inkl. <i>incl.</i>	30	46.6	I	099A0630S01
	9.3	15.7	12.5	8	M6	30	9.0		099A0830S01
inkl. Montageset 3 <i>With assembly set 3</i>	13.7	19.7	16.0	8	inkl. <i>incl.</i>	40	18.6	I	099A0840S01

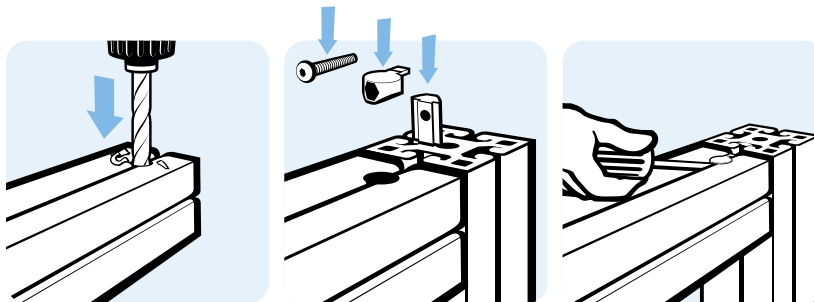



DOPPELNUTENSTEIN 13,7 × 7,0 MM, EINSCHWENKBAR *ROLL-IN DOUBLE T-SLOT NUT 13.7 × 7.0 MM*

Ausführung	Nut 8, Stahl	Model	Slot 8, steel
Beschreibung	einschwenkbarer Doppelnutenstein	Description	Roll-in double T-slot nut
Material	Stahl, verzinkt	Material	Zinc plated steel
Liefereinheit	100 Stück	Pack Quantity	100 pieces
Extras	verschiedene Längen mit mehreren Gewinden in unterschiedlichen Größen auf Anfrage	Specials	Different lengths with multiple threads in different sizes available on request

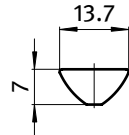
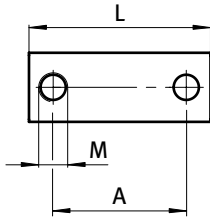

Doppelnutenstein <i>Double T-slot Nut</i>	A [mm]	L [mm]	Größe <i>Size</i>	Gewicht [g] <i>Weight [g]</i>	Profil <i>Profile</i>	Teil-Nr. <i>Part #</i>
	24.0	36.0	M8	14.0	I	096008D36
	64.0	76.0	M8	36.0	I	096008D76





UNIVERBINDER

UNIVERSAL CONNECTOR

Ausführung	Zinkdruckguss	Model	Zinc die-cast
Beschreibung	zur Verbindung von zwei Aluminiumprofilen	Description	To connect two aluminum profiles
Material	Univerbinder: Zinkdruckguss Montageset: Stahl	Material	Universal connector: Zinc die-cast Assembly set: Steel
Liefereinheit	100 Stück	Pack Quantity	100 pieces
Montageset	1 Schraube DIN 912 - M8 × 30, 1 Nutenstein M8, Nut 10, mit Federblech	Assembly Set	1 screw DIN 912 -M8 × 30, 1 T-slot nut, slot 10, with spring leaf
Liefereinheit Set	10 Stück	Pack Quantity Set	10 pieces

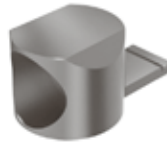
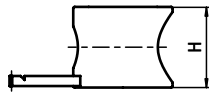
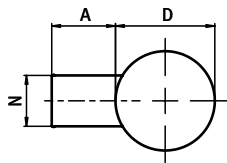

Verbinder Connector	A [mm]	D [mm]	H [mm]	N	für Schraube for Screw	Gewicht [g] Weight [g]	Profil Profile	Teil-Nr. Part #
	12.7	19.7	16.0	10	M8	14.0		099A1045
inkl. Montageset <i>With assembly set</i>	12.7	19.7	16.0	10	M8	14.0	B	099A1045S03

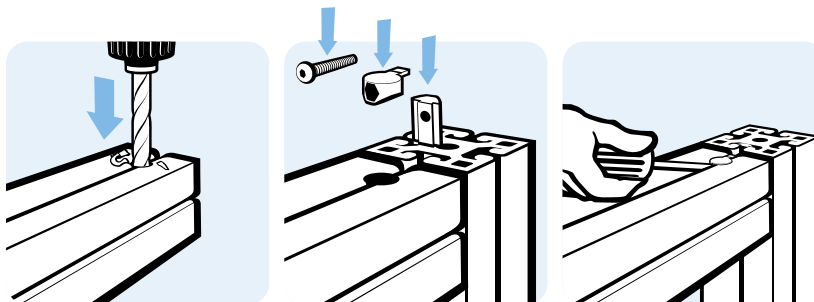

4



UNI-STOßVERBINDER

BUTT FASTENING UNIVERSAL CONNECTOR

Ausführung	Zinkdruckguss	Model	Zinc die-cast
Beschreibung	zur stirnseitigen Verbindung von zwei Aluminiumprofilen der gleichen Baureihe; inkl. Montageset	Description	End-to-end connection of two aluminum profiles of the same type; assembly set included
Material	Zinkdruckguss	Material	Zinc die-cast
Liefereinheit	10 Stück	Pack Quantity	10 pieces
Hinweis	*ohne Mutter, Gewinde im Gegenstück	Tip	*without Nut, thread integrated

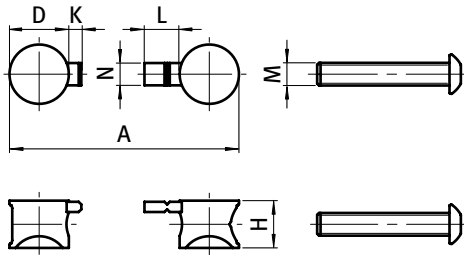

Uni-Stoßverbinder <i>Butt Fastening Universal Connector</i>	A [mm]	D [mm]	H [mm]	K [mm]	L [mm]	N	Schraube <i>Screw</i>	Gewicht [g] <i>Weight [g]</i>	Teil-Nr. <i>Part #</i>
	32.0	11.8	8.5		5.4	5	M4	9.8	099A0520S02
	46.0	15.7	12.5	3.3	9.3	6	M6	14.7	099A0630S03
	60.0	19.7	16.0		13.8	8	M8	19.6	*099A0840S02

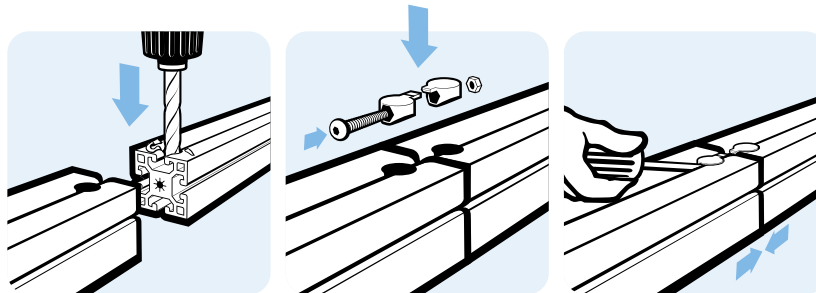

4

AUTOMATIKVERBINDER

AUTOMATIC CONNECTOR

Ausführung Stahl	Model Steel
Beschreibung zur schnellen und stabilen Verbindung von zwei Aluminiumprofilen ohne Profilbearbeitung; selbstschneidendes Gewinde	Description To connect two aluminum profiles fast and solid, assembly without machining; self-cutting thread
Material Stahl	Material Steel
Liefereinheit 100 Stück	Pack Quantity 100 pieces
Hinweis * passende Abdeckkappe siehe Seite 436	Tip * Compatible cover cap screw see page 436

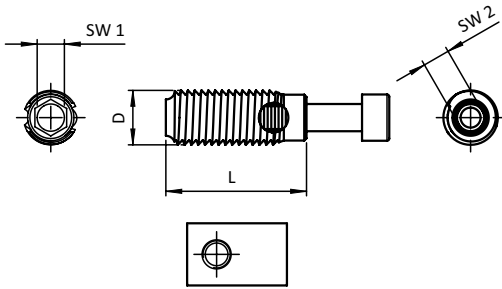

Automatikverbinder Automatic Connectors	D [mm]	L [mm]	SW1	SW2	Nut Slot	Profilbreite Profile Width	Schraube Screw	Gewicht [g] Weight [g]	Profil Profile	Teil-Nr. Part #
Schneidhülse Cutting sleeve	7.0	24.0		4	5	20		2.5	I	099GS051
	10.0	27.0		5	6	30		7.5	I	099GS061
	10.7	24.0		5	8	30		7.5	B	099GS084
	12.0	31.0		6	8	40		13.0	I	*099GS081
	12.0	35.0		6	10	40, 45		15.5	B	099GS102
	13.0	35.0		6	10	45		17.0	B	099GS103
	18.0	47.0		8	12	60		51.0	I	099GS121
inkl. Montageset mit Schraube und Nutenstein (I) / Hammermutter (B) With assembly set, incl. screw and T-slot nut (I) / hammer nut (B)	7.0	24.0	3	4	5	20	M4 × 30	8.0	I	099G051
	10.0	27.0	4	5	6	30	M5 × 35	18.0	I	099G061
	10.7	24.0	4	5	8	30	M5 × 30	16.5	B	099G084
	12.0	31.0	5	6	8	40	M6 × 40	33.0	I	*099G081
	12.0	35.0	5	6	10	40, 45	M6 × 45	33.5	B	099G102
	13.0	35.0	5	6	10	45	M6 × 45	35.0	B	099G103
	18.0	47.0	6	8	12	60	M8 × 60	150.0	I	099G121

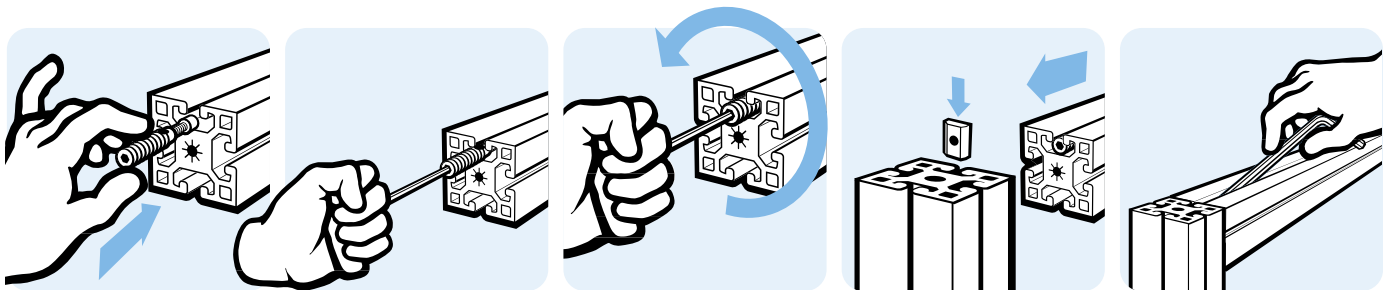



AUTOMATIKVERBINDER

AUTOMATIC CONNECTOR

Ausführung	Edelstahl	Model	Stainless steel
Beschreibung	zur schnellen und stabilen Verbindung von zwei Aluminiumprofilen ohne Profilbearbeitung; selbstschneidendes Gewinde	Description	To connect two aluminum profiles fast and solid, assembly without machining; self-cutting thread
Material	Edelstahl	Material	Stainless steel
Liefereinheit	100 Stück	Pack Quantity	100 pieces
Hinweis	* passende Abdeckkappe siehe Seite 436	Tip	* Compatible cover cap screw see page 436



Automatikverbinder <i>Automatic Connectors</i>	D [mm]	L [mm]	SW 1	SW 2	Nut Slot	Profilbreite Profile Width	Schraube Screw	Gewicht [g] Weight [g]	Profil Profile	Teil-Nr. Part #
Schneidhülse <i>Cutting sleeve</i>	7.0	24.0		4	5	20		2.7	I	099GS051E
	10.0	27.0		5	6	30		7.4	I	099GS061E
	12.0	31.0		6	8	40		13.0	I	*099GS081E
inkl. Montageset mit Schraube und Nutenstein <i>With assembly set, incl. screw and T-slot nut</i>	7.0	24.0	3	4	5	20	M4 × 30	8.0	I	099G051E
	10.0	27.0	4	5	6	30	M5 × 35	18.0	I	099G061E
	12.0	31.0	5	6	8	40	M6 × 40	33.0	I	*099G081E

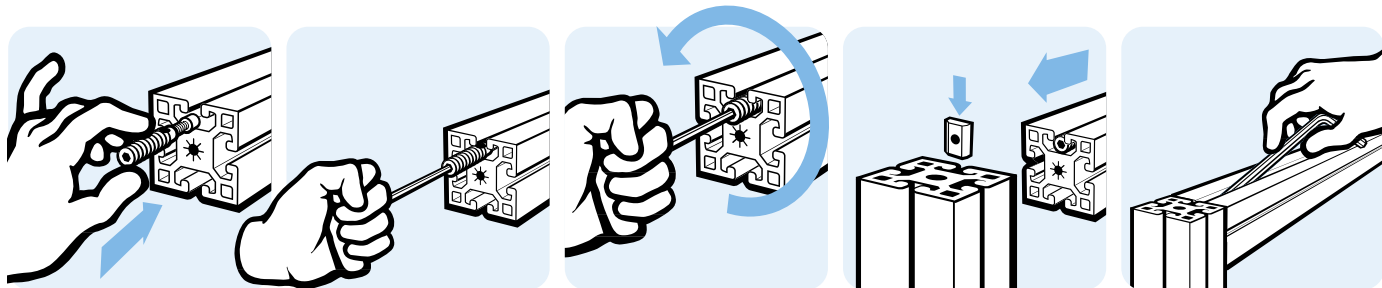



DOPPELNUTENSTEIN 13,7 × 7,0 MM, EINSCHWENKBAR *ROLL-IN DOUBLE T-SLOT NUT 13.7 × 7.0 MM*

Ausführung	Nut 8, Stahl	Model	Slot 8, steel
Beschreibung	einschwenkbarer Doppelnutenstein	Description	Roll-in double T-slot nut
Material	Stahl, verzinkt	Material	Zinc plated steel
Liefereinheit	100 Stück	Pack Quantity	100 pieces
Extras	verschiedene Längen mit mehreren Gewinden in unterschiedlichen Größen auf Anfrage	Specials	Different lengths with multiple threads in different sizes available on request

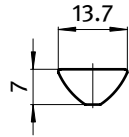
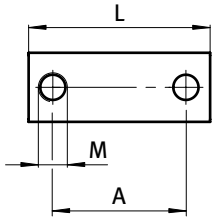

Doppelnutenstein <i>Double T-slot Nut</i>	A [mm]	L [mm]	Größe <i>Size</i>	Gewicht [g] <i>Weight [g]</i>	Profil <i>Profile</i>	Teil-Nr. <i>Part #</i>
	26.4	36.0	M6	16.0	I	096006D36
	66.4	76.0	M6	38.0	I	096006D76



AUTOMATIK-DOPPELVERBINDER (SET)

AUTOMATIC DOUBLE CONNECTOR (SET)

Ausführung	Stahl	Model	Steel
Beschreibung	zur schnellen und stabilen Verbindung von zwei Aluminiumprofilen ohne Profilbearbeitung; selbstschneidendes Gewinde	Description	To connect two aluminum profiles fast and solid, assembly without machining; self-cutting thread
Material	Stahl	Material	Steel
Liefereinheit	100 Stück	Pack Quantity	100 pieces
Hinweis	* passende Abdeckkappe siehe Seite 436	Tip	* Compatible cover cap screw see page 436

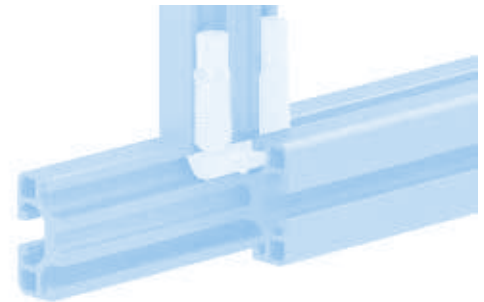
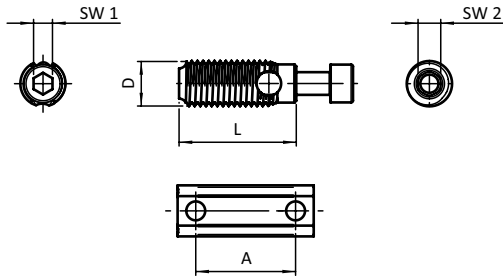

Automatik-Doppelverbinder <i>Automatic Double Connector</i>	A [mm]	D [mm]	L [mm]	SW 1	SW 2	Nut Slot	Profilbreite Profile Width	Schraube Screw	Gewicht [g] Weight [g]	Profil Profile	Teil-Nr. Part #
	26.4	12.0	31.0	6	5	8	40	M6 × 40	48.0	I	099G081D40
	66.4	12.0	31.0	6	5	8	80	M6 × 40	62.0	I	099G081D80
⚡ elektrostatisch entladend <i>electrostatically discharging</i>	26.4	12.0	31.0	6	5	8	40	M6 × 40	48.0	I	099G081D40ESD
	66.4	12.0	31.0	6	5	8	80	M6 × 40	62.0	I	099G081D80ESD





AUTOMATIK-STOßVERBINDER

AUTOMATIC BUTT CONNECTOR

Ausführung	Stahl	Model	Steel
Beschreibung	zur schnellen stirnseitigen Verbindung von zwei Aluminiumprofilen ohne Profilbearbeitung; selbstschneidendes Gewinde	Description	To face-to-face connect two aluminum profiles fast, assembly without machining; self-cutting thread
Material	Stahl	Material	Steel
Oberfläche	verzinkt	Surface	Zinc plated
Liefereinheit	100 Stück	Pack Quantity	100 pieces
Hinweis	* passende Abdeckkappe siehe Seite 436	Tip	* Compatible cover cap screw see page 436

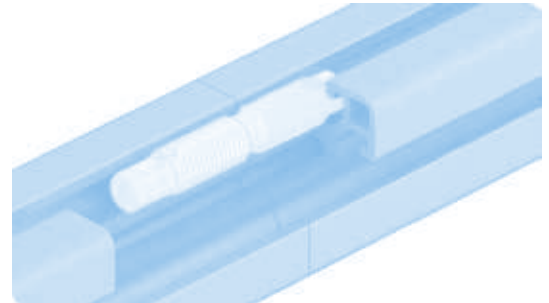
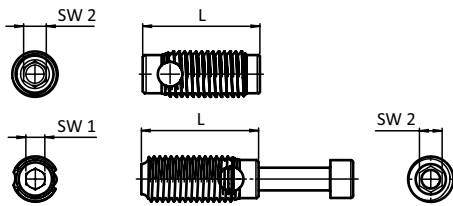

Automatik-Stoßverbinder <i>Automatic Butt Connectors</i>	D [mm]	L [mm]	SW1	SW2	ESD	Nut Slot	Profilbreite Profile Width	Schraube Screw	Gewicht [g] Weight [g]	Profil Profile	Teil-Nr. Part #
Gewinde-Schneidhülse <i>Threaded cutting sleeve</i>	7.0	24.0		4		5	20		2.7	I	099GS051M4
	10.0	27.0		5		6	30		7.4	I	099GS061M5
	10.7	24.0		5		8	30		8.0	B	099GS084M5
	12.0	31.0		6		8	40		13.0	I	*099GS081M6
	12.0	35.0		6		10	40, 45		17.0	B	099GS102M6
	13.0	35.0		6		10	45		18.5	B	099GS103M6
inkl. Montageset mit Schraube und Schneidhülse <i>With assembly set, incl. screw and threaded cutting sleeve</i>	7.0	24.0	3	4		5	20	M4 × 40	10.0	I	099G051M4
	10.0	27.0	4	5		6	30	M5 × 45	24.0	I	099G061M5
	10.7	24.0	4	5		8	30	M5 × 45	23.6	B	099G084M5
	12.0	31.0	5	6		8	40	M6 × 50	43.0	I	*099G081M6
	12.0	35.0	5	6		10	40, 45	M6 × 60	49.0	B	099G102M6
	13.0	35.0	5	6		10	45	M6 × 60	56.0	B	099G103M6



AUTOMATIK-STOßVERBINDER

AUTOMATIC BUTT CONNECTOR

Ausführung	Edelstahl	Model	Stainless steel
Beschreibung	zur schnellen stirnseitigen Verbindung von zwei Aluminiumprofilen ohne Profilbearbeitung; selbstschneidendes Gewinde	Description	To face-to face connect two aluminum profiles fast, assembly without machining; self-cutting thread
Material	Edelstahl	Material	Stainless steel
Liefereinheit	100 Stück	Pack Quantity	100 pieces
Hinweis	* passende Abdeckkappe siehe Seite 436	Tip	* Compatible cover cap screw see page 436

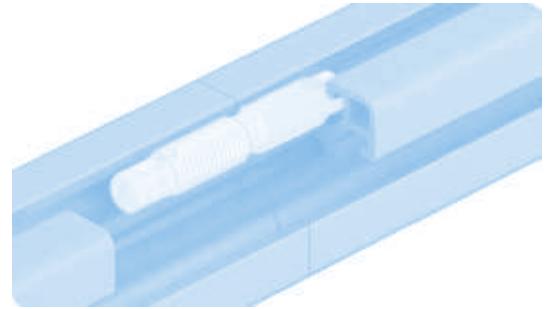
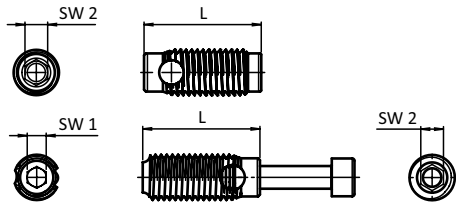

Automatik-Stoßverbinder Automatic Butt Connectors	D [mm]	L [mm]	SW1	SW2	ESD	Nut Slot	Profilbreite Profile Width	Schraube Screw	Gewicht [g] Weight [g]	Profil Profile	Teil-Nr. Part #
Gewinde-Schneidhülse Threaded cutting sleeve	7.0	24.0		4		5	20		2.7	I	099GS051M4E
	10.0	27.0		5		6	30		7.4	I	099GS061M5E
	12.0	31.0		6		8	40		13.0	I	* 099GS081M6E
inkl. Montageset mit Schraube und Schneidhülse With assembly set, incl. screw and threaded cutting sleeve	7.0	24.0	3	4		5	20	M4 × 40	10.0	I	099G051M4E
	10.0	27.0	4	5		6	30	M5 × 45	24.0	I	099G061M5E
	12.0	31.0	5	6		8	40	M6 × 50	43.0	I	* 099G081M6E



ABDECKKAPPE FÜR AUTOMATIKVERBINDER

COVER CAP FOR AUTOMATIC CONNECTOR

Ausführung	Kunststoff PA	Model	Plastic PA
Beschreibung	zum Abdecken des Automatikverbinders mit Hül- senlänge 31 mm in der Profilnut 8	Description	To cover the 31 mm-sleeve Automatic Connector within a slot 8
Material	Kunststoff PA, glasfaserverstärkt	Material	Plastic PA, glass fiber reinforced
Farbe	schwarz	Color	Black
Liefereinheit	100 Stück	Pack Quantity	100 pieces

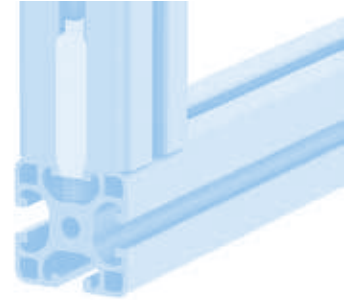
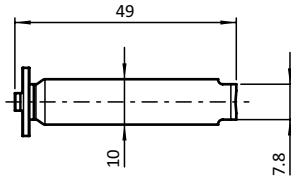

Abdeckkappe für Automatikverbinder
 Cover Cap for Automatic Connector

Gewicht [g]
 Weight [g]

Profil
 Profile

Teil-Nr.
 Part #

1.0

I

099GA081K

4

T-MATIC VERBINDER

T-MATIC CONNECTOR

Ausführung	Stahl	Model	Steel
Beschreibung	zur schnellen und stabilen Verbindung von zwei Aluminiumprofilen ohne Profilbearbeitung; selbstformendes Gewinde ohne Spanbildung	Description	To connect two aluminum profiles fast and solid, assembly without machining; self-forming thread, without chipping
Material	Stahl, verzinkt	Material	Zinc plated steel
Liefereinheit	100 Stück	Pack Quantity	100 pieces
Hinweis	* leicht eindrehbare Version mit geringerem Eindrehwiderstand ** passendes Abdeckblech siehe Seite 442	Tip	* Version with lower screw-in resistance ** Compatible cover plate see page 442

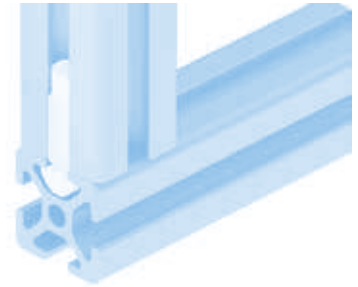
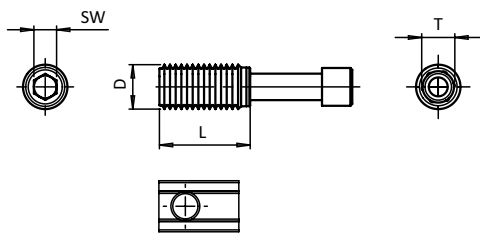

T-Matic Verbinder T-Matic Connector	D [mm]	L [mm]	SW	T	ESD	Nut Slot	Profilbreite Profile Width	Schraube Screw	Gewicht [g] Weight [g]	Profil Profile	Teil-Nr. Part #
ohne Nutenstein Without T-slot nut	7.0	14.0	3	T25		5	20	M4 × 20	4.0	I	099H051
	7.0	24.0	3	T25		5	20	M4 × 30	6.4	I	099H053
	10.0	20.0	5	T40		6	30	M6 × 29	11.0	I	099H061
	11.5	24.0	5	T45		8	30	M6 × 34	15.5	B	099H083
	12.0	24.0	6	T50		8	40	M8 × 35	21.0	I	099H081 **
	11.5	24.0	6	T50		8	40	M8 × 35	20.3	I	099H081L* **
	12.0	32.0	6	T50		8	40	M8 × 43	27.0	I	099H082
	14.0	24.0	6	T50		8	45	M8 × 37	31.5		099H084
	12.0	24.0	6			10	40, 45	M8 × 37	21.0	B	099H102
	13.0	24.0	6			10	45	M8 × 37	26.0	B	099H101
mit Nutenstein With T-slot nut	7.0	14.0	3	T25		5	20	M4 × 20	6.0	I	099H052
	7.0	24.0	3	T25		5	20	M4 × 30	8.2	I	099H054
	10.0	20.0	5	T40		6	30	M6 × 29	16.0	I	099H062
	11.5	24.0	5			8	30	M6 × 34	15.0	B	099H087
	12.0	24.0	6			8	40	M8 × 35	30.0	I	099H085 **
	11.5	24.0	6			8	40	M8 × 35	29.0	I	099H085L* **
	12.0	32.0	6			8	40	M8 × 43	36.0	I	099H086
	14.0	24.0	6			8	45	M8 × 37	40.5		099H088
	12.0	24.0	6			10	40, 45	M8 × 37	32.0	B	099H104
	13.0	24.0	6			10	45	M8 × 37	37.0	B	099H103
	7.0	14.0	3	T25	ESD	5	20	M4 × 20	6.0	I	099H052ESD
	7.0	24.0	3	T25	ESD	5	20	M4 × 30	8.2	I	099H054ESD
	10.0	20.0	5	T40	ESD	6	30	M6 × 29	16.0	I	099H062ESD
	11.5	24.0	5		ESD	8	30	M6 × 34	15.0	B	099H087ESD
	12.0	24.0	6		ESD	8	40	M8 × 35	30.0	I	099H085ESD **
	11.5	24.0	6		ESD	8	40	M8 × 35	29.0	I	099H085LES* **
	12.0	32.0	6		ESD	8	40	M8 × 43	36.0	I	099H086ESD
	12.0	24.0	6		ESD	10	40, 45	M8 × 37	32.0	B	099H104ESD
	13.0	24.0	6		ESD	10	45	M8 × 37	37.0	B	099H103ESD



T-MATIC VERBINDER

T-MATIC CONNECTOR

Ausführung	Edelstahl	Model	Stainless steel
Beschreibung	zur schnellen und stabilen Verbindung von zwei Aluminiumprofilen ohne Profilbearbeitung; selbstformendes Gewinde ohne Spanbildung	Description	To connect two aluminum profiles fast and solid, assembly without machining; self-forming thread, without chipping
Material	Edelstahl	Material	Stainless steel
Liefereinheit	100 Stück	Pack Quantity	100 pieces
Hinweis	* passendes Abdeckblech siehe Seite 442	Tip	* Compatible cover plate see page 442

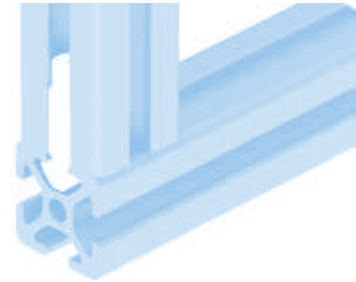
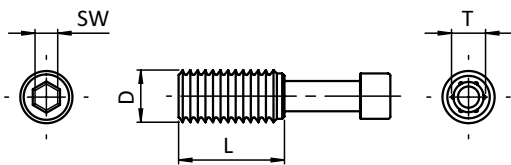

T-Matic Verbinder T-Matic Connector	D [mm]	L [mm]	SW	T	ESD	Nut Slot	Profilbreite Profile Width	Schraube Screw	Gewicht [g] Weight [g]	Profil Profile	Teil-Nr. Part #
	12.0	24.0	6	T50		8	40	M8 × 35	21.5	I	*099H081E
mit Nutenstein With T-slot nut	12.0	24.0	6	T50		8	40	M8 × 35	30.0	I	*099H085E
	12.0	24.0	6	T50		8	40	M8 × 35	30.0	I	*099H085EESD

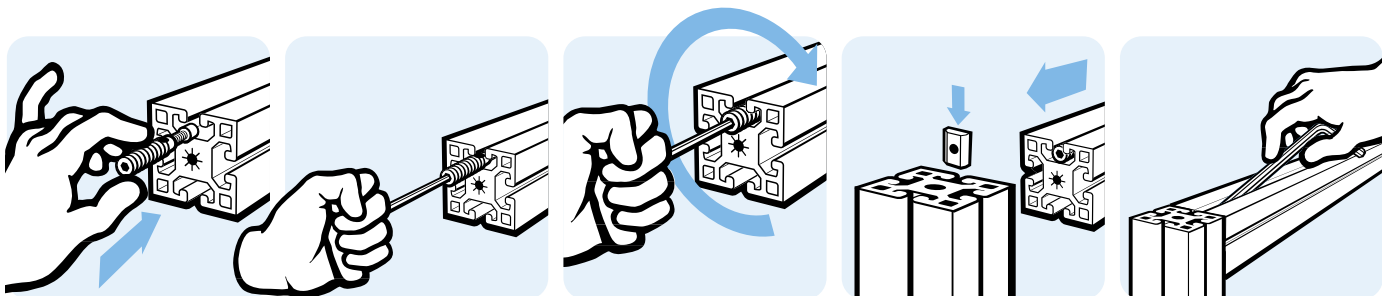

T-MATIC DOPPELVERBINDER

T-MATIC DOUBLE CONNECTOR

Ausführung	Stahl	Model	Steel
Beschreibung	zur schnellen und stabilen Verbindung von zwei Aluminiumprofilen ohne Profilbearbeitung; selbstformendes Gewinde ohne Spanbildung	Description	To connect two aluminum profiles fast and solid, assembly without machining; self-forming thread, without chipping
Material	Stahl, verzinkt	Material	Zinc plated steel
Liefereinheit	100 Stück	Pack Quantity	100 pieces
Hinweis	* passendes Abdeckblech siehe Seite 442	Tip	* Compatible cover plate see page 442

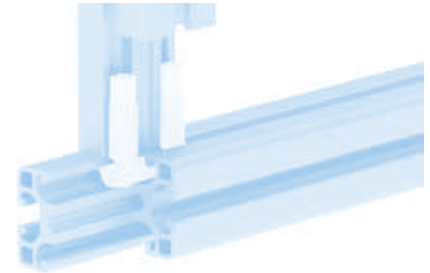
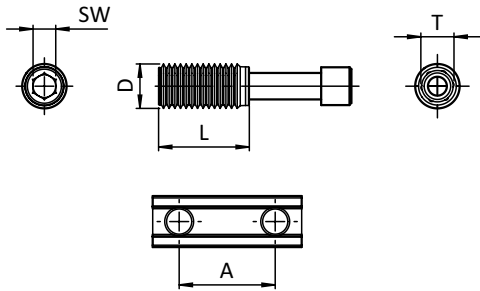

T-Matic Doppelverbinder T-Matic Double Connector	A [mm]	D [mm]	L [mm]	SW	T	Nut Slot	Profilbreite Profile Width	Schraube Screw	Gewicht [g] Weight [g]	Profil Profile	Teil-Nr. Part #
	13.5	7.0	14.0	3	T25	5	20	M4 × 20	11.0	I	099H052D20
	13.5	7.0	24.0	3	T25	5	20	M4 × 30	16.0	I	099H054D20
	33.5	7.0	24.0	3	T25	5	40	M4 × 30	21.5	I	099H054D40
	20.0	11.5	24.0	5	T45	8	30	M6 × 34	44.0	B	099H087D30
	50.0	11.5	24.0	5	T45	8	60	M6 × 34	60.4	B	099H087D60
	25.4	12.0	24.0	6	T50	8	40	M8 × 35	58.0	I	*099H085D40
	65.4	12.0	24.0	6	T50	8	80	M8 × 35	80.5	I	*099H085D80
	25.4	12.0	32.0	6	T50	8	40	M8 × 43	69.0	I	099H086D40
	65.4	12.0	32.0	6	T50	8	80	M8 × 43	92.0	I	099H086D80
⚡ elektrostatisch entladend electrostatically discharging	13.5	7.0	14.0	3	T25	5	20	M4 × 20	11.0	I	099H052D20ESD
	13.5	7.0	24.0	3	T25	5	20	M4 × 30	16.0	I	099H054D20ESD
	20.0	11.5	24.0	5	T45	8	30	M6 × 34	44.0	B	099H087D30ESD
	50.0	11.5	24.0	5	T45	8	60	M6 × 34	60.4	B	099H087D60ESD
	25.4	12.0	24.0	6	T50	8	40	M8 × 35	58.0	I	*099H085D40ESD
	65.4	12.0	24.0	6	T50	8	80	M8 × 35	80.5	I	*099H085D80ESD
	25.4	12.0	32.0	6	T50	8	40	M8 × 43	69.0	I	099H086D40ESD
	65.4	12.0	32.0	6	T50	8	80	M8 × 43	92.0	I	099H086D80ESD



T-MATIC DOPPELVERBINDER

T-MATIC DOUBLE CONNECTOR

Ausführung	Edelstahl	Model	Stainless steel
Beschreibung	zur schnellen und stabilen Verbindung von zwei Aluminiumprofilen ohne Profilbearbeitung; selbstformendes Gewinde ohne Spanbildung	Description	To connect two aluminum profiles fast and solid, assembly without machining; self-forming thread, without chipping
Material	Edelstahl	Material	Stainless steel
Liefereinheit	100 Stück	Pack Quantity	100 pieces
Hinweis	* passendes Abdeckblech siehe Seite 442	Tip	* Compatible cover plate see page 442

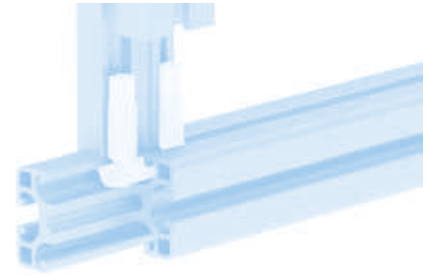
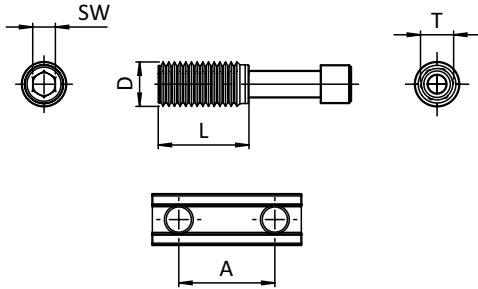

T-Matic Doppelverbinder T-Matic Double Connector	A [mm]	D [mm]	L [mm]	SW	T	Nut Slot	Schraube Screw	Gewicht [g] Weight [g]	Profil Profile	Teil-Nr. Part #
	25.5	12.0	24.0	6	T50	8	M8 × 35	36.5	I	*099H085ED40
	25.5	12.0	24.0	6	T50	8	M8 × 35	36.0	I	*099H085ED80
⚡ elektrostatisch entladend electrostatically discharging	25.5	12.0	24.0	6	T50	8	M8 × 35	36.5	I	*099H085ED40ESD
	25.5	12.0	24.0	6	T50	8	M8 × 35	36.0	I	*099H085ED80ESD



T-MATIC STOßVERBINDER

T-MATIC BUTT CONNECTOR

Ausführung Stahl	Model Steel
Beschreibung zur schnellen stirnseitigen Verbindung von zwei Aluminiumprofilen ohne Profilbearbeitung; selbstformendes Gewinde ohne Spanbildung	Description To face-to-face connect two aluminum profiles fast, assembly without machining; self-forming thread, without chipping
Material Stahl	Material Steel
Liefereinheit 100 Stück	Pack Quantity 100 pieces



T-Matic Stoßverbinder	D [mm]	L [mm]	SW	T	ESD	Nut Slot	Profilbreite Profile Width	Schraube Screw	Gewicht [g] Weight [g]	Profil Profile	Teil-Nr. Part #
T-Matic Einschraubgewindehülse <i>T-Matic Screw-in Threaded Sleeve</i>	7.0	24.0		T25		5	20		3.7	I	099HS053M4
	10.0	20.0		T40		6	30		4.0	I	099HS061M6
	12.0	24.0		T50		8	40		9.3	I	099HS081M8
	11.5	24.0		T45		8	30		7.7	B	099HS083M6
	12.0	24.0		T50		10	40, 45		8.3	B	099HS102M8
	13.0	24.0		T50		10	45		12.1	B	099HS101M8
T-Matic Stoßverbinder <i>T-Matic Butt Connector</i>	7.0	24.0	3	T25		5	20	M4 × 45	11.5	I	099H054M4ESD
	10.0	20.0	5	T40		6	30	M6 × 40	17.0	I	099H062M6ESD
	11.5	24.0	5	T45		8	30	M6 × 50	27.0	B	099H087M6ESD
	12.0	24.0	6	T50		8	40	M8 × 50	35.0	I	099H085M8ESD
	13.0	24.0	6	T50		10	45	M8 × 50	43.8	B	099H103M8ESD
	12.0	24.0	6	T50		10	40, 45	M8 × 50	35.5	B	099H104M8ESD





ABDECKBLECH FÜR T-MATIC VERBINDER

COVER PLATE FOR T-MATIC CONNECTOR

Ausführung	Edelstahl	Model	Stainless steel
Beschreibung	zum Abdecken des T-Matic Verbinders mit Hülslenlänge 24mm in der Profilvernut 8	Description	To cover the 24 mm-sleeve T-matic connector within a slot 8
Material	Edelstahl	Material	Stainless steel
Liefereinheit	100 Stück	Pack Quantity	100 pieces

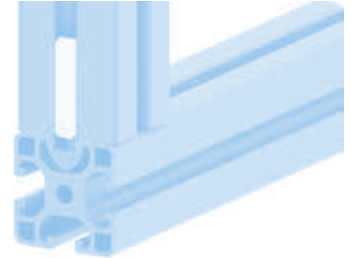
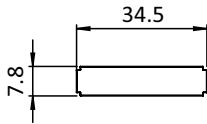

Abdeckblech Cover Plate	Gewicht [g] Weight [g]	Profil Profile	Teil-Nr. Part #
	0.7	I	099HA081E

4

TORXSCHLÜSSEL

TORX KEY

Ausführung	für T-Matic Verbinder	Model	For T-matic connectors
Beschreibung	zum Eindrehen des T-Matic Verbinders in die Profilvernut, mit besonders langem Schaft, Torx mit hoher Passgenauigkeit und Stecktiefe	Description	To screw in the T-matic connector into the slot, extra long shank, high-precision Torx with extended plug-in depth
Material	Stahl, verzinkt	Material	Zinc plated steel
Liefereinheit	1 Stück	Pack Quantity	1 piece

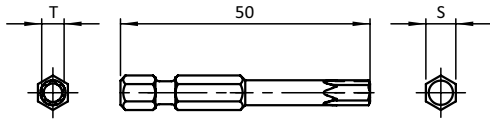

Torxschlüssel <i>Torx Key</i>	L [mm]	S [mm]	T	Gewicht [g] <i>Weight [g]</i>	Teil-Nr. <i>Part #</i>
für Bit-Aufnahme (Akkuschrauber) <i>For bit receptacle (cordless screwdriver)</i>	50.0	6.33	T25	9.5	099HT25
	50.0	6.33	T40	12.0	099HT40
	50.0	6.33	T45	14.5	099HT45
	50.0	6.33	T50	16.5	099HT50
für Spannfutter (Bohrmaschine) <i>For jaw chuck (drill machine)</i>	90.0	9.0	T50	49.0	099HT50L





FRÄSVERBINDER PROFIL 30

MILLING CONNECTOR PROFILE 30

Ausführung	Stahl, Nut 8	Model	Steel, slot 8
Beschreibung	zur schnellen und stabilen Verbindung von zwei Aluminiumprofilen; Montage ohne Profilbearbeitung	Description	To connect two aluminum profiles fast and solid; assembly without machining
Material	Stahl, verzinkt	Material	Zinc plated steel
Set	1 Fräsverbinder, 1 Schraube DIN 912 - M5 × 18, 1 Hammermutter	Set	1 milling connector, 1 screw DIN 912 - M5 × 18, 1 hammer nut
Liefereinheit	10 Stück	Pack Quantity	10 pieces

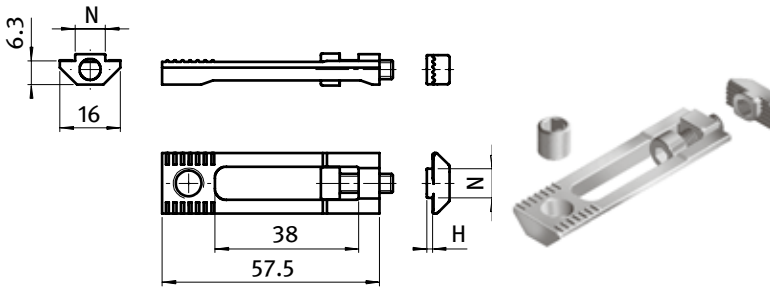

Fräsverbinder Profil 30 Milling Connector Profile 30	H [mm]	N	Gewicht [g] Weight [g]	Profil Profile	Teil-Nr. Part #
Set	1.5	8	31.7	B	099D0830M0515

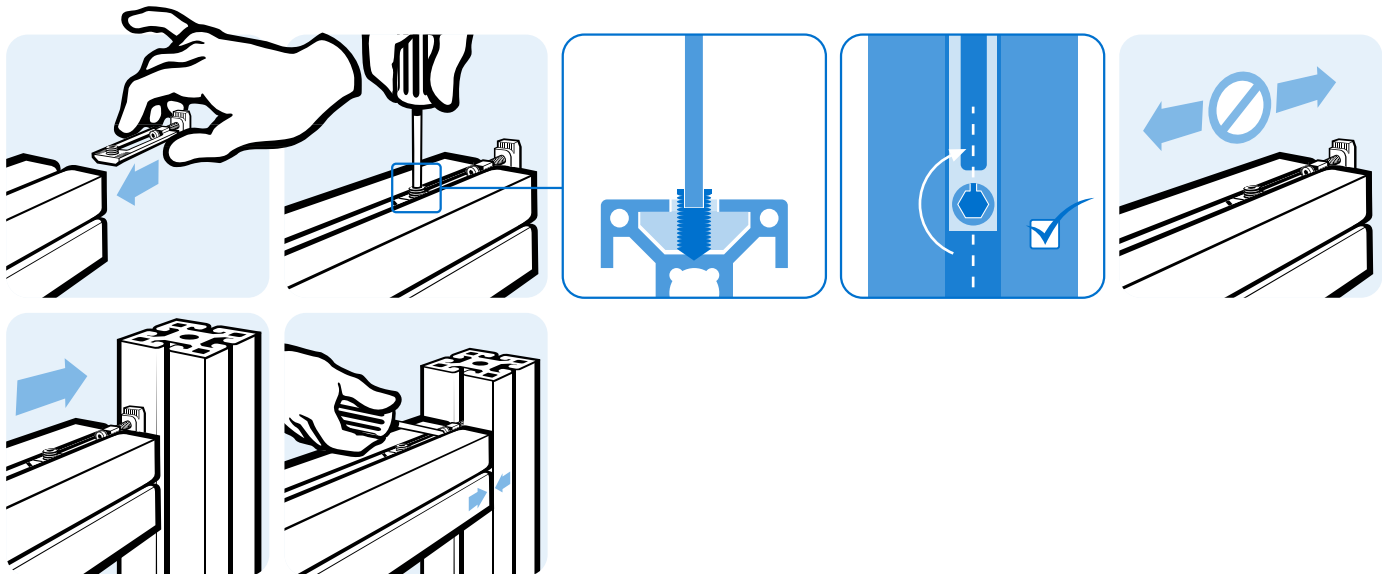



FRÄSVERBINDER PROFIL 40

MILLING CONNECTOR PROFILE 40

Ausführung	Stahl, Nut 8	Model	Steel, slot 8
Beschreibung	zur schnellen und stabilen Verbindung von zwei Aluminiumprofilen; Montage ohne Profilbearbeitung	Description	To connect two aluminum profiles fast and solid; assembly without machining
Material	Stahl, verzinkt	Material	Zinc plated steel
Set	1 Fräsverbinder, 1 Schraube DIN 912 - M5 x 18, 1 Hammermutter	Set	1 milling connector, 1 screw DIN 912 - M5 x 18, 1 hammer nut
Liefereinheit	10 Stück	Pack Quantity	10 pieces

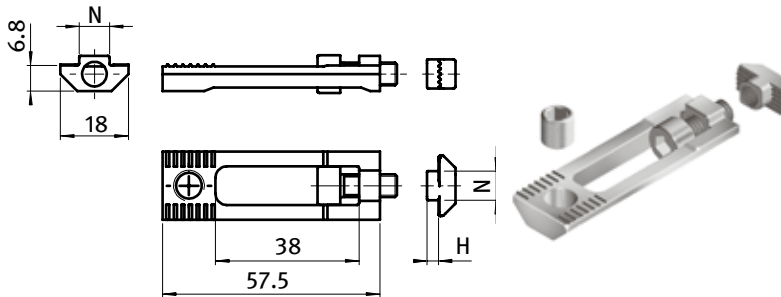

Fräsverbinder Profil 40 Milling Connector Profile 40	H [mm]	N	Gewicht [g] Weight [g]	Profil Profile	Teil-Nr. Part #
Set	3.0	8	37.3	I	099D0840M0530

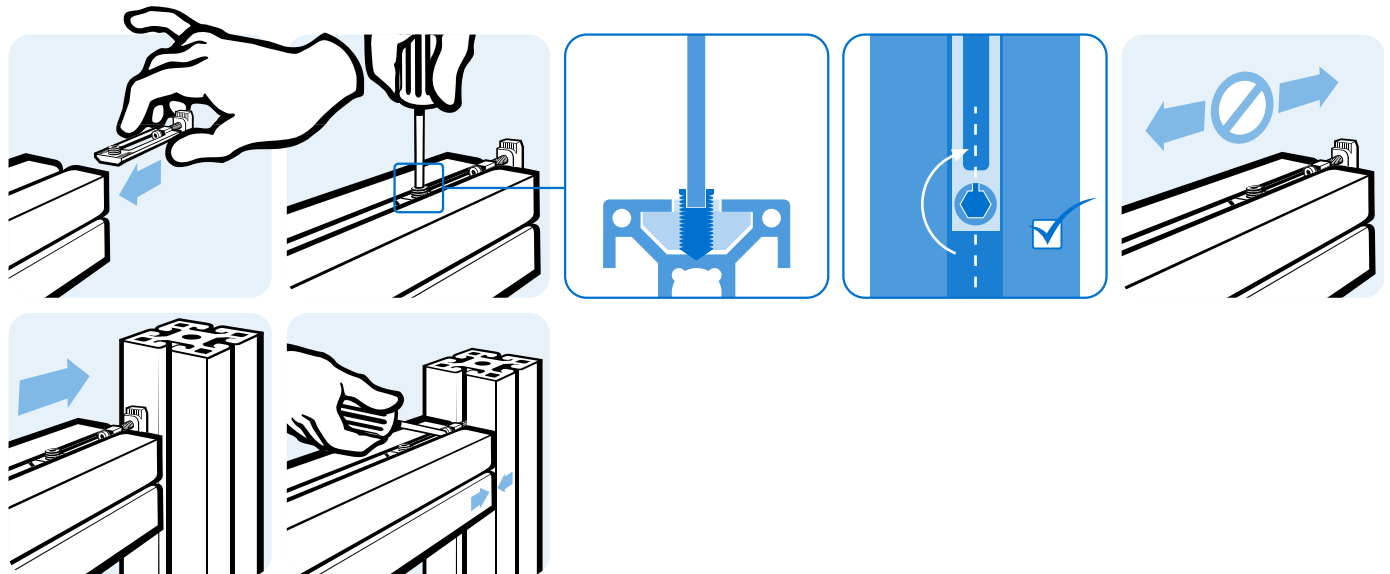

4



FRÄSVERBINDER PROFIL 45

MILLING CONNECTOR PROFILE 45

Ausführung	Stahl, Nut 10	Model	Steel, slot 10
Beschreibung	zur schnellen und stabilen Verbindung von zwei Aluminiumprofilen; Montage ohne Profilbearbeitung	Description	To connect two aluminum profiles fast and solid; assembly without machining
Material	Stahl, verzinkt	Material	Zinc plated steel
Set	1 Fräsverbinder, 1 Schraube DIN 912 - M6 × 18, 1 Hammermutter	Set	1 milling connector, 1 screw DIN 912 - M6 × 18, 1 hammer nut
Liefereinheit	10 Stück	Pack Quantity	10 pieces

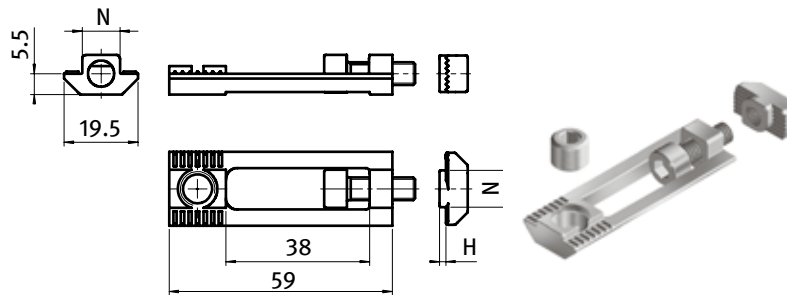

Fräsverbinder Profil 45 Milling Connector Profile 45	H [mm]	N	Gewicht [g] Weight [g]	Profil Profile	Teil-Nr. Part #
Set	1.5	10	38.0		099D1045M0617
Set	3.0	10	38.1	B	099D1045M0630

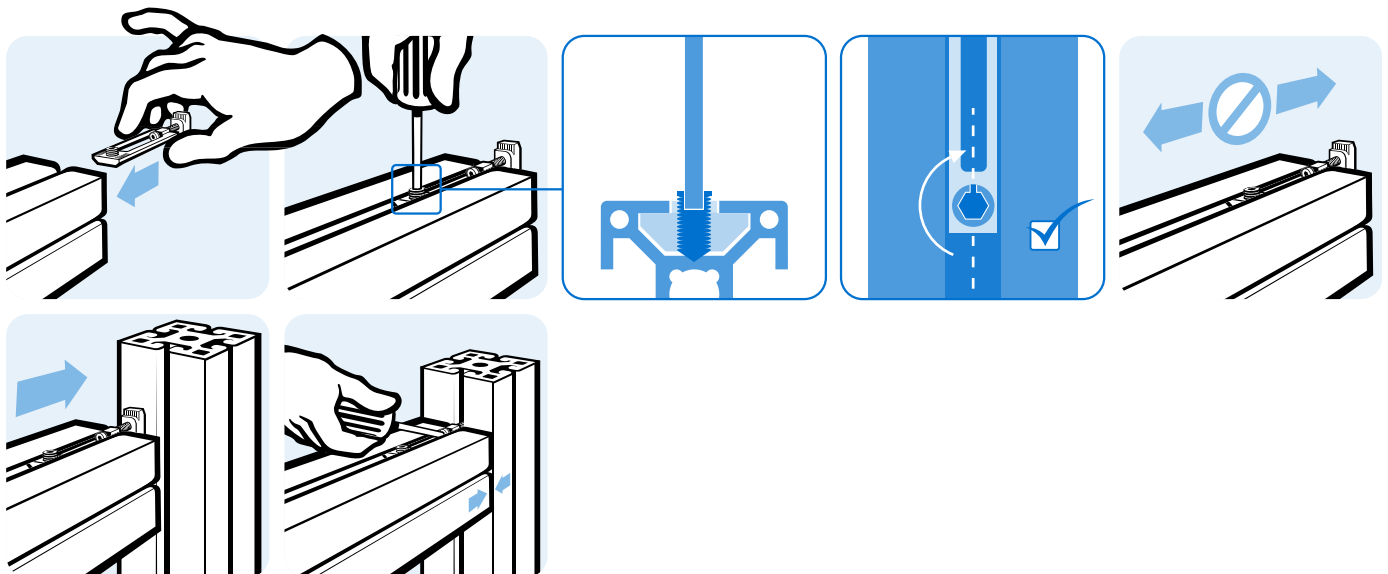

4



SCHRAUBENVERBINDER

SCREW CONNECTOR

Ausführung Nut 5, 6, 8, 12	Model Slot 5, 6, 8, 12
Beschreibung zur Verbindung von zwei Aluminiumprofilen, Zähne brechen die Eloxalschicht auf und schaffen eine sichere, elektrostatisch entladende Verbindung	Description To connect two aluminum profiles; penetrates the anodized coat of the profile - thus ensuring a safe, electrostatically discharging connection
Material Stahl / Edelstahl	Material Steel / stainless steel
Liefereinheit 100 Stück	Pack Quantity 100 pieces

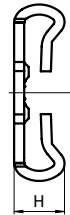
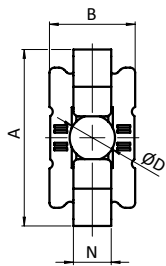

Schraubenverbinder <i>Screw Connectors</i>	A × B [mm]	D [mm]	H [mm]	N	ESD	Gewicht [g] <i>Weight [g]</i>	Profil <i>Profile</i>	Teil-Nr <i>Part#</i>
Verdrehsicherung <i>Turn-lock</i>	19.0 × 10.0	5.5	4.4	5		1.8		092038
	27.5 × 13.0	6.5	7.3	6		5.4		092039
	35.0 × 17.0	9.0	10.0	8		10.6		092040
	55.0 × 26.0	13.0	10.0	12		37.0		092040N12
	± 35.0 × 17.0	9.0	10.0	8		10.6		092040E
inkl. Linsenkopfschraube <i>With pan-head screw</i>	19.0 × 10.0	5.5	4.4	5		5.0		099F0520M05
	27.5 × 13.0	6.5	7.3	6		9.0		099F0630M06
	35.0 × 17.0	9.0	10.0	8		20.7		099F0840M08
	± 35.0 × 17.0	9.0	10.0	8		20.7		099F0840M08E
inkl. selbstformende Schraube S7 × 20 <i>With self forming screw S7 × 20</i>	35.0 × 17.0	9.0	10.0	8		21.0	I	099F0840S07

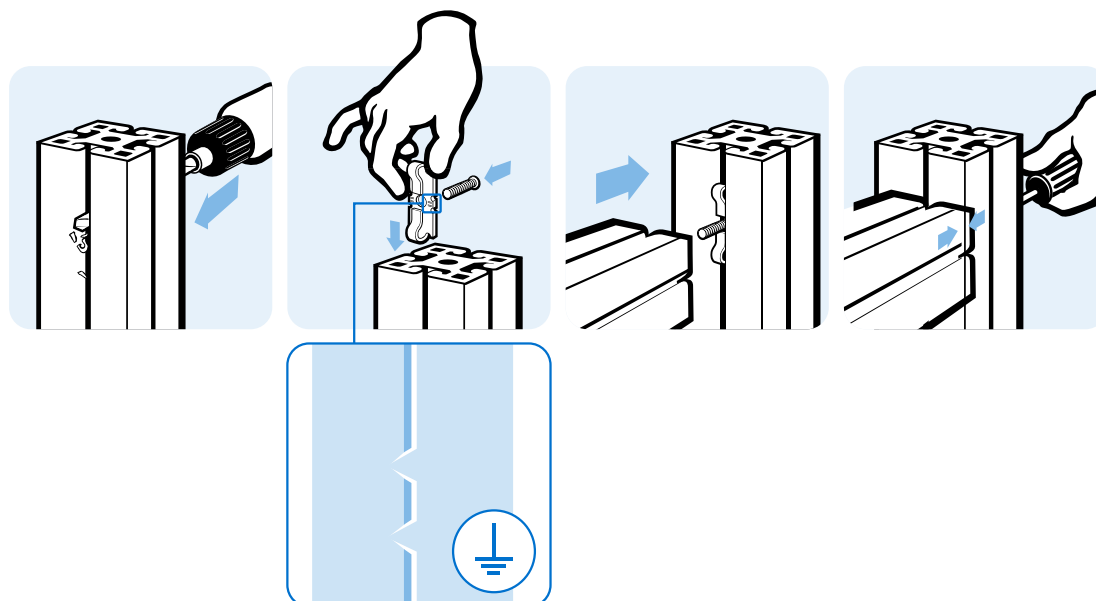



SCHRAUBENVERBINDER EINSEITIG

SCREW CONNECTOR, SINGLE SIDE

Ausführung	Nut 8	Model	Slot 8
Beschreibung	zur Verbindung von zwei Aluminiumprofilen, Zähne brechen die Eloxalschicht auf und schaffen eine sichere, elektrostatisch entladende Verbindung; freie Nut für Flächenelemente auf einer Seite	Description	To connect two aluminum profiles; penetrates the anodized coat of the profile - thus ensuring a safe, electrostatically discharging connection; free slot for the mounting of panels on one side
Material	Stahl	Material	Steel
Oberfläche	verzinkt	Surface	Zinc plated
Liefereinheit	100 Stück	Pack Quantity	100 pieces

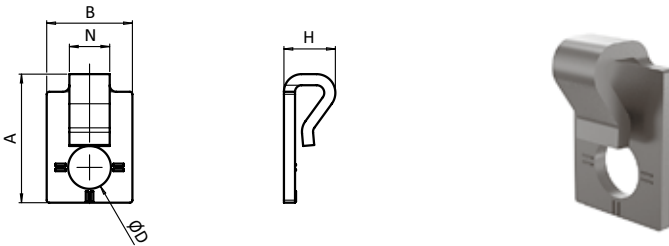

Schraubenverbinder einseitig <i>Screw Connector, Single Side</i>	A × B [mm]	D [mm]	H [mm]	N	ESD	Gewicht [g] <i>Weight [g]</i>	Profil <i>Profile</i>	Teil-Nr. <i>Part #</i>
Verdrehsicherung <i>Turn-lock</i>	25.5 × 17.0	8.5	10.2	5		8.6		092140
inkl. Linsenkopfschraube M8 × 20 <i>With pan-head screw M8 × 20</i>	25.5 × 17.0	8.5	10.2	5		20.0		099F0840SM08
inkl. selbstformender Schraube S7 × 20 <i>With self-forming screw S7 × 20</i>	25.5 × 17.0	8.5	10.2	6		20.0	I	099F0840SS07



SCHRAUBENVERBINDER

SCREW CONNECTOR

Ausführung	Nut 10	Model	Slot 10
Beschreibung	zur Verbindung von zwei Aluminiumprofilen	Description	To connect two aluminum profiles
Material	Stahl, verzinkt	Material	Zinc plated steel
Liefereinheit	100 Stück	Pack Quantity	100 pieces

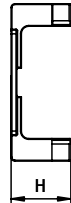
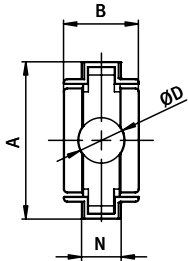

Schraubenverbinder <i>Screw Connector</i>	A × B [mm]	D [mm]	H [mm]	N	Schraube <i>Screw</i>	Gewicht [g] <i>Weight [g]</i>	Profil <i>Profile</i>	Teil-Nr. <i>Part #</i>
	41.6 × 20.0	12.0	15.8	10	M12 × 40	16.0		092092
inkl. Selbstformender Schraube <i>With self forming screw</i>	41.6 × 20.0	12.0	15.8	10	M12 × 40	47.0	B	099F1045S13
inkl. Schraube mit Torx <i>With Torx screw</i>	41.6 × 20.0	12.0	15.8	10	M12 × 30	42.0		099F1045S11

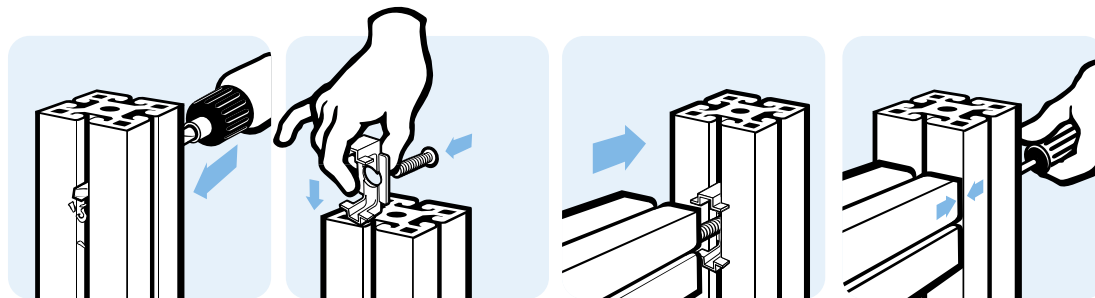

INNENVERBINDER NUT 6

INNER CONNECTOR SLOT 6

Ausführung	Edelstahl	Model	Stainless steel
Beschreibung	zur Verbindung von zwei Aluminiumprofilen, Montage ohne Profilbearbeitung, kann auch als Innenverbinder R Nut 6 verwendet werden	Description	To connect two aluminum profiles; assembly without machining, can also be used as inner connector R Slot 6
Material	Edelstahl	Material	Stainless Steel
Set	2 Gewindestifte	Set	2 hexagon socket set screws
Liefereinheit	100 Stück	Pack Quantity	100 pieces

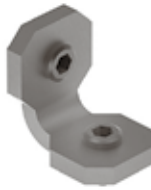
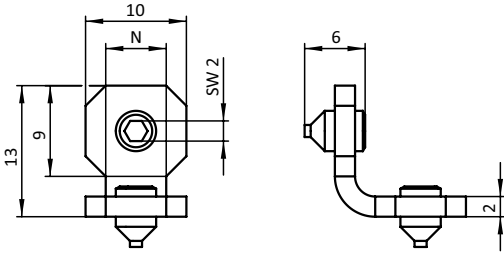

Innenverbinder Nut 6 Inner Connector Slot 6	Gewindestifte Hexagon socket set screws	N	Gewicht [g] Weight [g]	Profil Profile	Teil-Nr. Part #
	M4	6	3.0	B	099I9006

4



INNENVERBINDER

INNER CONNECTOR

Ausführung	Stahlguss / Zinkdruckguss	Model	Steel cast / zinc die-cast
Beschreibung	zur Verbindung von zwei Aluminiumprofilen, Montage ohne Profilbearbeitung	Description	To connect two aluminum profiles, assembly without machining
Material	Innenverbinder Ausführung ST: Stahlguss, verzinkt Innenverbinder Ausführung ZN: Zinkdruckguss, verzinkt Gewindestifte: Stahl, verzinkt	Material	Inner Connector ST version: Zinc-plated cast steel Inner Connector ZN version: Zinc-plated zinc die-cast Hexagon socket set screws: Zinc-plated steel
Liefereinheit	10 Stück	Pack Quantity	10 pieces



Innenverbinder Inner Connector	Gewindestifte Hexagon socket set screws	A [mm]	B [mm]	H [mm]	L1 [mm]	L2 [mm]	N [mm]	Gewicht [g] Weight [g]	Profil Profile	Teil-Nr. Part #
ST Stahlguss <i>ST cast steel</i>	M6	15.8	7.8	6.0	21.0	30.0	8	27.0	B	099I9008M
ST Stahlguss <i>ST cast steel</i>	M8	19.0	8.8	3.8	32.0	38.0	10	51.0	B	099I9010M
ZN Zinkdruckguss <i>ZN zinc die-cast</i>	M6	15.8	7.8	6.0	21.0	30.0	8	24.0	B	099I9008
ZN Zinkdruckguss <i>ZN zinc die-cast</i>	M8	19.0	8.8	3.8	32.0	38.0	10	44.0	B	099I9010



INNENVERBINDER R

INNER CONNECTOR R

Ausführung	Stahlguss / Zinkdruckguss	Model	Steel cast / zinc die-cast
Beschreibung	zur Verbindung von zwei Aluminiumprofilen, Montage ohne Profilbearbeitung	Description	To connect two aluminum profiles, assembly without machining
Material	Innenverbinder Ausführung ST: Stahlguss, verzinkt Innenverbinder Ausführung ZN: Zinkdruckguss, verzinkt Gewindestifte: Stahl, verzinkt	Material	Inner Connector ST version: Zinc-plated cast steel Inner Connector ZN version: Zinc-plated zinc die-cast Hexagon socket set screws: Zinc-plated steel
Liefereinheit	10 Stück	Pack Quantity	10 pieces

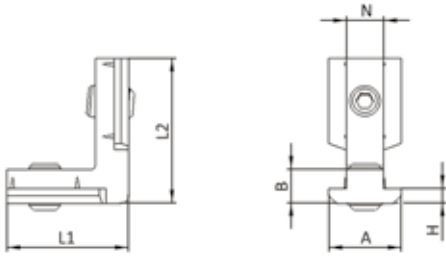

Innenverbinder R Inner Connector R	Gewindestift Hexagon socket set screw	A [mm]	B [mm]	H [mm]	L1 [mm]	L2 [mm]	N [mm]	Gewicht [g] Weight [g]	Profil Profile	Teil-Nr. Part #
ST Stahlguss <i>ST cast steel</i>	M5	11.3	4.5	3.0	21.0	21.0	6	9.8	B	099I90R06M
ST Stahlguss <i>ST cast steel</i>	M6	15.8	7.8	6.0	21.0	30.0	8	27.0	B	099I90R08M
ST Stahlguss <i>ST cast steel</i>	M8	19.0	8.8	3.8	32.0	38.0	10	51.0	B	099I90R10M
ZN Zinkdruckguss <i>ZN zinc die-cast</i>	M5	11.3	4.5	3.0	21.0	21.0	6	8.0	B	099I90R06
ZN Zinkdruckguss <i>ZN zinc die-cast</i>	M6	15.8	7.8	6.0	21.0	30.0	8	24.0	B	099I90R08
ZN Zinkdruckguss <i>ZN zinc die-cast</i>	M8	19.0	8.8	3.8	32.0	38.0	10	45.0	B	099I90R10

4



WINKELVERBINDER 40/20, 45°

ANGLE CONNECTOR 40/20, 45°

Ausführung	Aluminiumdruckguss	Model	Aluminum die-cast
Beschreibung	zur einfachen Verbindung von zwei Aluminiumprofilen im 45° Winkel	Description	To connect two aluminum profiles at 45°
Material	Aluminiumdruckguss	Material	Aluminum die-cast
Liefereinheit	10 Stück	Pack Quantity	10 pieces
Extras	weitere Oberflächen, weitere Farben auf Anfrage	Specials	Other surfaces, other colors on request

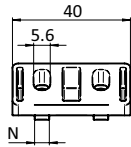
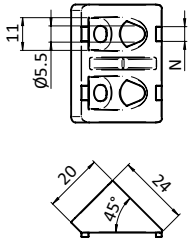

Winkelverbinder 40/20, 45° Angle Connector 40/20, 45°	N	für Schraube for Screw	Gewicht [g] Weight [g]	Teil-Nr. Part #
blank <i>Plain</i>	5	M5	19.2	093WS40445N05R
alufarbig <i>Alu color</i>	5	M5	19.2	093WS40445N05

4



WINKELVERBINDER 40/80, 45°

ANGLE CONNECTOR 40/80, 45°

Ausführung Zinkdruckguss	Model Zinc die-cast
Beschreibung zur einfachen Verbindung von zwei Aluminiumprofilen im 45° Winkel	Description To connect two aluminum profiles at 45°
Material Zinkdruckguss	Material Zinc die-cast
Liefereinheit 10 Stück	Pack Quantity 10 pieces

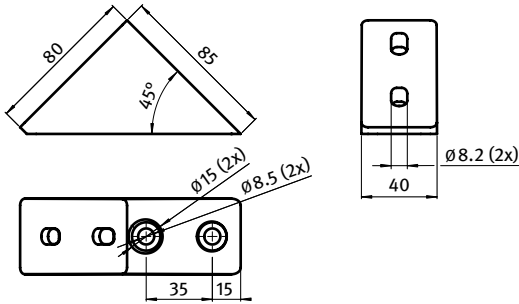

Winkelverbinder 40/80, 45°
Angle Connector 40/80, 45°

	für Schraube for Screw	Gewicht [g] Weight [g]	Teil-Nr. Part #
blank <i>Plain</i>	M8	350.0	093WS40245R
alufarbig <i>Alu color</i>	M8	350.0	093WS40245

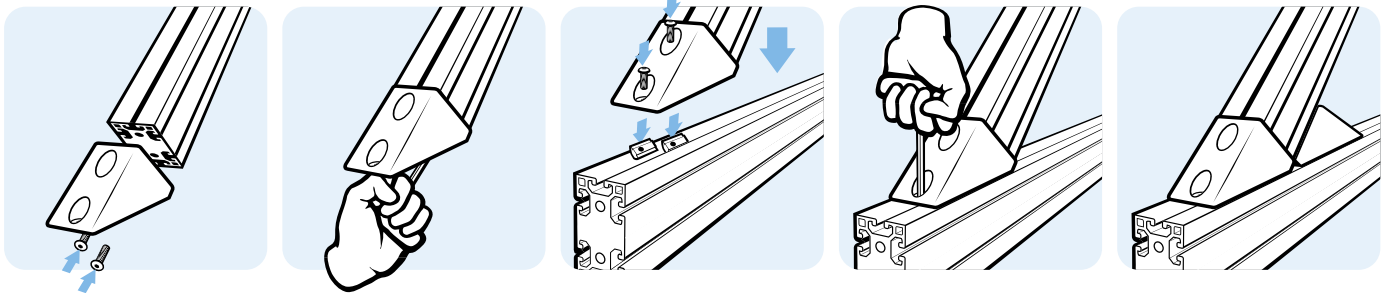



WINKELVERBINDER 25 - 1", 45°

ANGLE CONNECTOR 25 - 1", 45°

Ausführung	Aluminiumdruckguss	Model	Aluminum die-cast
Beschreibung	zur einfachen Verbindung von zwei Aluminiumprofilen im 45° Winkel	Description	To connect two aluminum profiles at 45°
Material	Aluminiumdruckguss	Material	Aluminum die-cast
Liefereinheit	10 Stück	Pack Quantity	10 pieces
Extras	weitere Oberflächen, weitere Farben auf Anfrage	Specials	Other surfaces, other colors on request

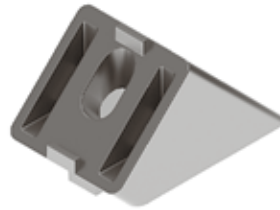
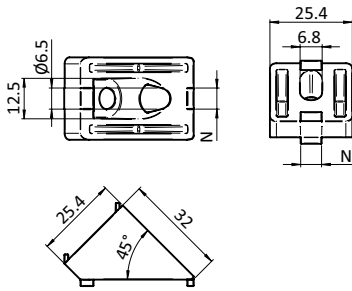

Winkelverbinder 25 - 1", 45° Angle Connector 25 - 1", 45°	N	für Schraube for Screw	Gewicht [g] Weight [g]	Teil-Nr. Part #
blank <i>Plain</i>	6.5	1/4"-20	30.1	093WS25145N6,5R
alufarbig <i>Alu color</i>	6.5	1/4"-20	30.1	093WS25145N6,5

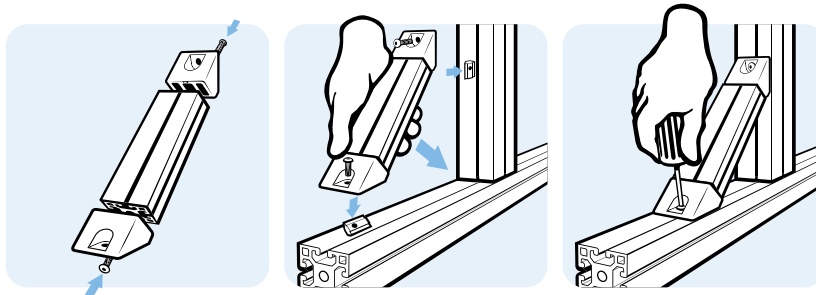



WINKELVERBINDER 51/25 - 2"/1", 45°

ANGLE CONNECTOR 51/25 - 2"/1", 45°

Ausführung Aluminiumdruckguss
Beschreibung zur einfachen Verbindung von zwei Aluminiumprofilen im 45° Winkel
Material Aluminiumdruckguss
Liefereinheit 10 Stück
Extras weitere Oberflächen, weitere Farben auf Anfrage

Model Aluminum die-cast
Description To connect two aluminum profiles at 45°
Material Aluminum die-cast
Pack Quantity 10 pieces
Specials Other surfaces, other colors on request

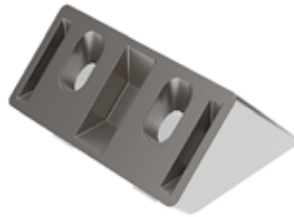
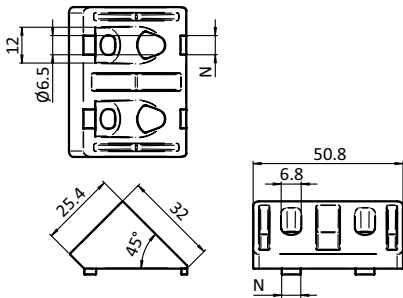

Winkelverbinder 51/25 - 2"/1", 45° Angle Connector 51/25 - 2"/1", 45°	N	für Schraube for Screw	Gewicht [g] Weight [g]	Teil-Nr. Part #
blank <i>Plain</i>	6.5	1/4"-20	41.2	093WS51145N6,5R
alufarbig <i>Alu color</i>	6.5	1/4"-20	41.2	093WS51145N6,5



WINKELVERBINDER 30, 45°

ANGLE CONNECTOR 30, 45°

Ausführung	Aluminiumdruckguss	Model	Aluminum die-cast
Beschreibung	zur einfachen Verbindung von zwei Aluminiumprofilen im 45° Winkel	Description	To connect two aluminum profiles at 45°
Material	Aluminiumdruckguss	Material	Aluminum die-cast
Liefereinheit	10 Stück	Pack Quantity	10 pieces
Extras	weitere Oberflächen, weitere Farben auf Anfrage	Specials	Other surfaces, other colors on request

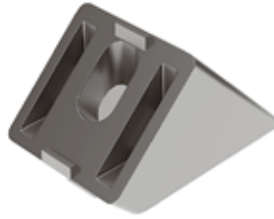
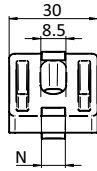
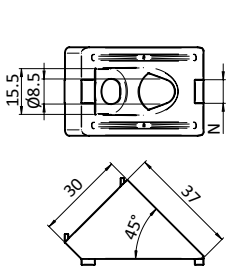

Winkelverbinder 30, 45°
Angle Connector 30, 45°

N

für Schraube
for Screw

Gewicht [g]
Weight [g]

Teil-Nr.
Part #

	N	für Schraube for Screw	Gewicht [g] Weight [g]	Teil-Nr. Part #
blank Plain	8	M8	33.5	093WS30245N08R
alufarbig Alu color	8	M8	33.5	093WS30245N08

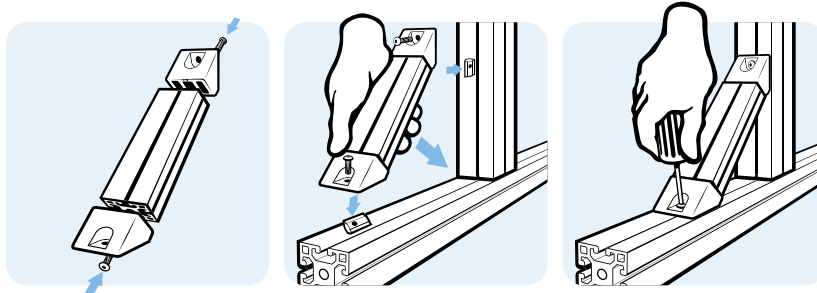



WINKELVERBINDER 60/30, 45°

ANGLE CONNECTOR 60/30, 45°

Ausführung	Aluminiumdruckguss	Model	Aluminum die-cast
Beschreibung	zur einfachen Verbindung von zwei Aluminiumprofilen im 45° Winkel	Description	To connect two aluminum profiles at 45°
Material	Aluminiumdruckguss	Material	Aluminum die-cast
Liefereinheit	10 Stück	Pack Quantity	10 pieces
Extras	weitere Oberflächen, weitere Farben auf Anfrage	Specials	Other surfaces, other colors on request

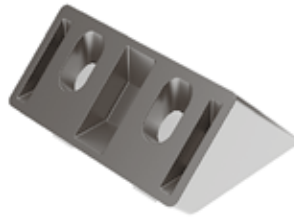
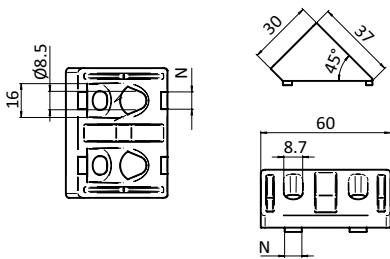

Winkelverbinder 60/30, 45° Angle Connector 60/30, 45°	N	für Schraube for Screw	Gewicht [g] Weight [g]	Teil-Nr. Part #
blank <i>Plain</i>	8	M8	41.2	093WS60145N08R
alufarbig <i>Alu color</i>	8	M8	41.2	093WS60145N08





WINKELVERBINDER 38 - 1,5", 45°

ANGLE CONNECTOR 38 - 1.5", 45°

Ausführung	Aluminiumdruckguss	Model	Aluminum die-cast
Beschreibung	zur einfachen Verbindung von zwei Aluminiumprofilen im 45° Winkel	Description	To connect two aluminum profiles at 45°
Material	Aluminiumdruckguss	Material	Aluminum die-cast
Liefereinheit	10 Stück	Pack Quantity	10 pieces
Extras	weitere Oberflächen, weitere Farben auf Anfrage	Specials	Other surfaces, other colors on request

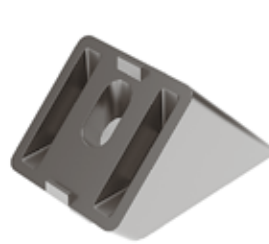
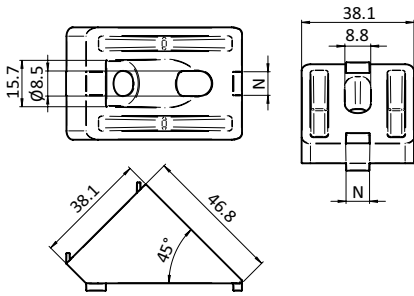

Winkelverbinder 38 - 1,5", 45° Angle Connector 38 - 1,5", 45°	N	für Schraube for Screw	Gewicht [g] Weight [g]	Teil-Nr. Part #
blank <i>Plain</i>	8	5/16"-18	69.1	093WS38145N08R
alufarbig <i>Alu color</i>	8	5/16"-18	69.1	093WS38145N08

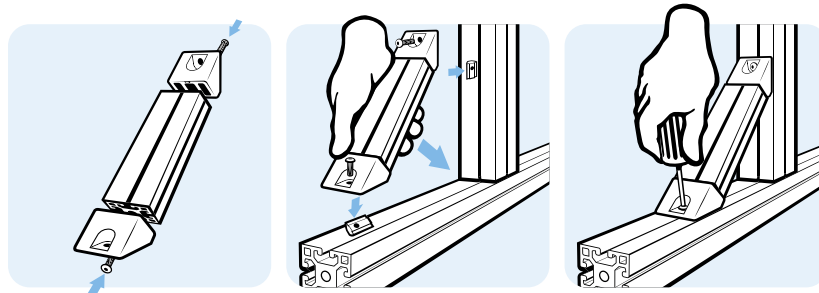

4



WINKELVERBINDER 76/38 - 3"/1,5", 45°

ANGLE CONNECTOR 76/38 - 3"/1.5", 45°

Ausführung	Aluminiumdruckguss	Model	Aluminum die-cast
Beschreibung	zur einfachen Verbindung von zwei Aluminiumprofilen im 45° Winkel	Description	To connect two aluminum profiles at 45°
Material	Aluminiumdruckguss	Material	Aluminum die-cast
Liefereinheit	10 Stück	Pack Quantity	10 pieces
Extras	weitere Oberflächen, weitere Farben auf Anfrage	Specials	Other surfaces, other colors on request

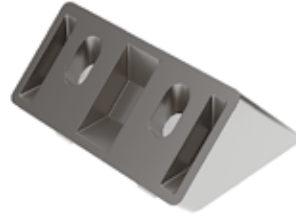
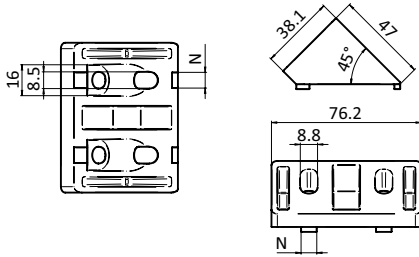

Winkelverbinder 76/38 - 3"/1,5", 45° Angle Connector 76/38 - 3"/1.5", 45°	N	für Schraube for Screw	Gewicht [g] Weight [g]	Teil-Nr. Part #
blank <i>Plain</i>	8	5/16"-18	135.2	093WS76145N08R
alufarbig <i>Alu color</i>	8	5/16"-18	135.2	093WS76145N08





WINKELVERBINDER 40, 45°

ANGLE CONNECTOR 40, 45°

Ausführung	Zinkdruckguss	Model	Zinc die-cast
Beschreibung	zur einfachen Verbindung von zwei Aluminiumprofilen im 45° Winkel	Description	To connect two aluminum profiles at 45°
Material	Zinkdruckguss	Material	Zinc die-cast
Liefereinheit	10 Stück	Pack Quantity	10 pieces
Extras	weitere Oberflächen, weitere Farben auf Anfrage	Specials	Other surfaces, other colors on request

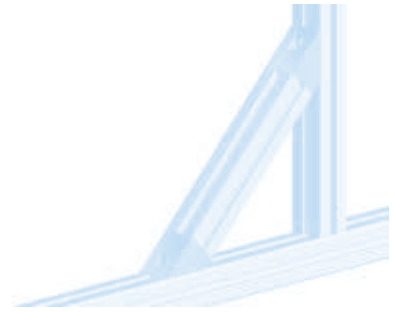
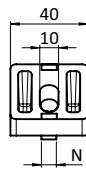
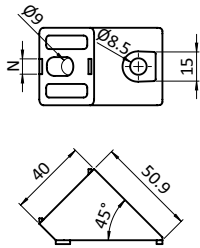

Winkelverbinder 40, 45° Angle Connector 40, 45°	N	für Schraube for Screw	Gewicht [g] Weight [g]	Teil-Nr. Part #
blank <i>Plain</i>	8	M8	209.0	093WS40145N08R
alufarbig <i>Alu color</i>	8	M8	214.0	093WS40145N08

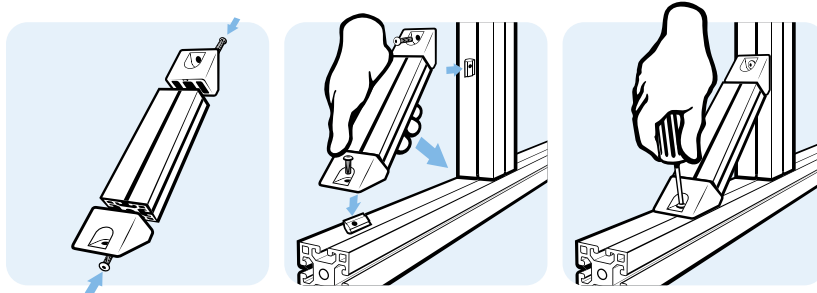



WINKELVERBINDER 40/80, 45°

ANGLE CONNECTOR 40/80, 45°

Ausführung Zinkdruckguss	Model Zinc die-cast
Beschreibung zur einfachen Verbindung von zwei Aluminiumprofilen im 45° Winkel	Description To connect two aluminum profiles at 45°
Material Zinkdruckguss	Material Zinc die-cast
Liefereinheit 10 Stück	Pack Quantity 10 pieces

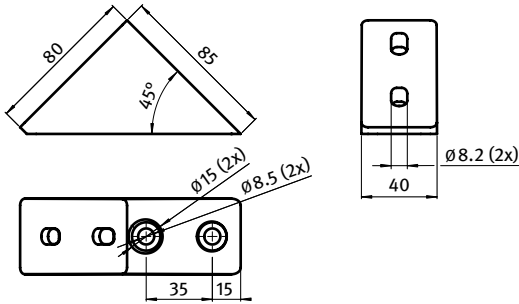

Winkelverbinder 40/80, 45°
Angle Connector 40/80, 45°

für Schraube
for Screw

Gewicht [g]
Weight [g]

Teil-Nr.
Part #

	für Schraube for Screw	Gewicht [g] Weight [g]	Teil-Nr. Part #
blank <i>Plain</i>	M8	350.0	093WS40245R
alufarbig <i>Alu color</i>	M8	350.0	093WS40245

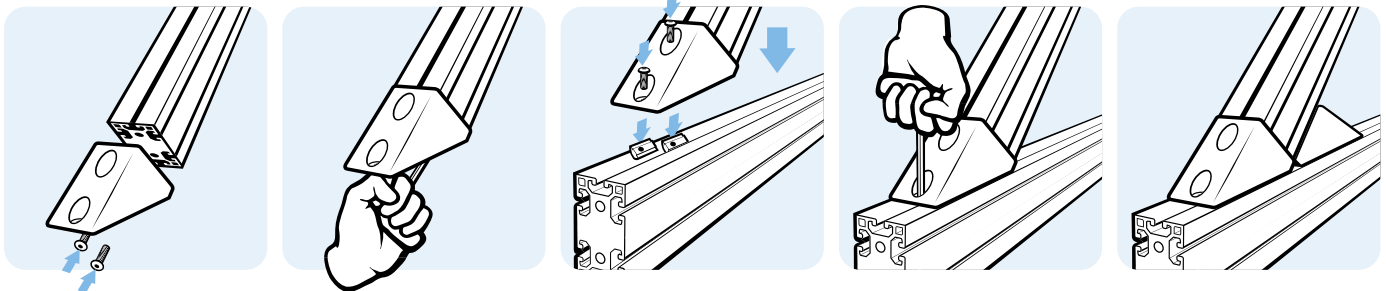



WINKELVERBINDER 80/40, 45°

ANGLE CONNECTOR 80/40, 45°

Ausführung	Aluminiumdruckguss	Model	Aluminum die-cast
Beschreibung	zur einfachen Verbindung von zwei Aluminiumprofilen im 45° Winkel	Description	To connect two aluminum profiles at 45°
Material	Aluminiumdruckguss	Material	Aluminum die-cast
Liefereinheit	10 Stück	Pack Quantity	10 pieces
Extras	weitere Oberflächen, weitere Farben auf Anfrage	Specials	Other surfaces, other colors on request

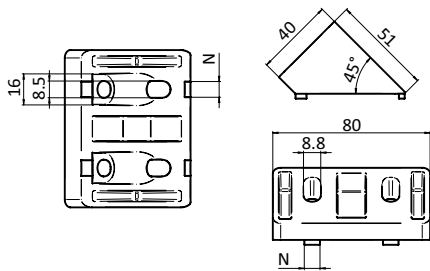

Winkelverbinder 80/40, 45° Angle Connector 80/40, 45°	N	für Schraube for Screw	Gewicht [g] Weight [g]	Teil-Nr. Part #
blank <i>Plain</i>	8	M8	166.2	093WS80145N08R
alufarbig <i>Alu color</i>	8	M8	166.2	093WS80145N08

4



WINKELVERBINDER 45, 45°

ANGLE CONNECTOR 45, 45°

Ausführung Aluminiumdruckguss
Beschreibung zur einfachen Verbindung von zwei Aluminiumprofilen im 45° Winkel
Material Aluminiumdruckguss
Liefereinheit 10 Stück
Extras weitere Oberflächen, weitere Farben auf Anfrage

Model Aluminum die-cast
Description To connect two aluminum profiles at 45°
Material Aluminum die-cast
Pack Quantity 10 pieces
Specials Other surfaces, other colors on request

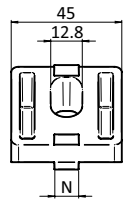
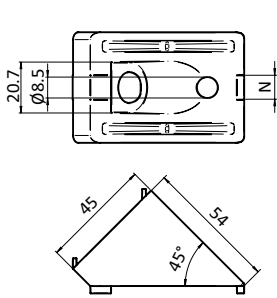

Winkelverbinder 45, 45° Angle Connector 45, 45°	N	für Schraube for Screw	Gewicht [g] Weight [g]	Teil-Nr. Part #
blank <i>Plain</i>	10	M12	112.4	093WS45245N10R
alufarbig <i>Alu color</i>	10	M12	112.4	093WS45245N10

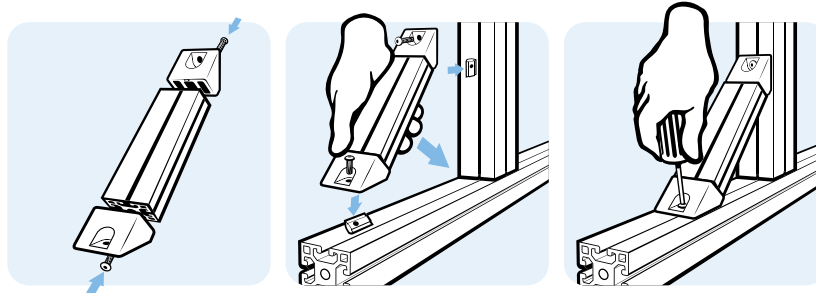



WINKELVERBINDER 90/45, 45°

ANGLE CONNECTOR 90/45, 45°

Ausführung	Aluminiumdruckguss	Model	Aluminum die-cast
Beschreibung	zur einfachen Verbindung von zwei Aluminiumprofilen im 45° Winkel	Description	To connect two aluminum profiles at 45°
Material	Aluminiumdruckguss	Material	Aluminum die-cast
Liefereinheit	10 Stück	Pack Quantity	10 pieces
Extras	weitere Oberflächen, weitere Farben auf Anfrage	Specials	Other surfaces, other colors on request

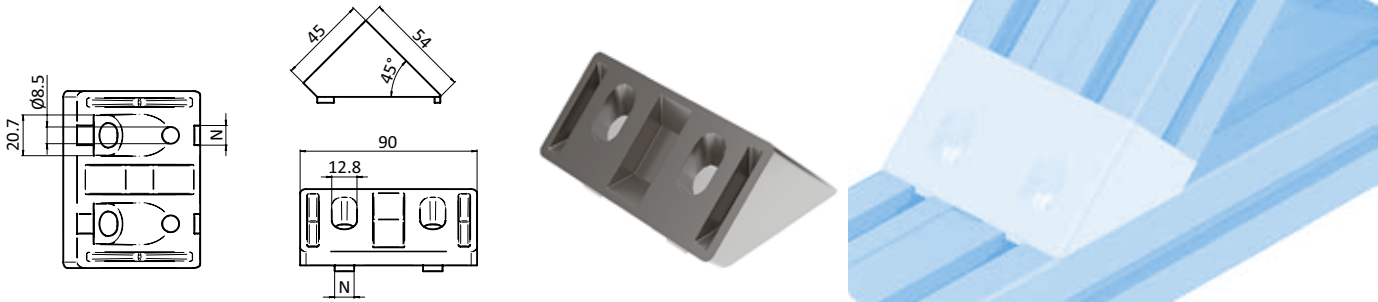

Winkelverbinder 90/45, 45° Angle Connector 90/45, 45°	N	für Schraube for Screw	Gewicht [g] Weight [g]	Teil-Nr. Part #
blank <i>Plain</i>	10	M12	216.2	093WS90145N10R
alufarbig <i>Alu color</i>	10	M12	216.2	093WS90145N10

4



WINKELVERBINDER 30, 45°

ANGLE CONNECTOR 30, 45°

Ausführung	Aluminiumdruckguss	Model	Aluminum die-cast
Beschreibung	zur einfachen Verbindung von zwei Aluminiumprofilen im 45° Winkel	Description	To connect two aluminum profiles at 45°
Material	Winkelverbinder: Aluminiumdruckguss Nutfixierungen: Kunststoff PA, glasfaserverstärkt Abdeckkappen: Kunststoff PA, glasfaserverstärkt Montageset: Stahl	Material	Angle connector: Aluminum die-cast Centering pieces: Plastic PA, glass fiber reinforced Cover caps: Plastic PA, glass fiber reinforced Assembly set: Steel
Liefereinheit	10 Stück	Pack Quantity	10 pieces

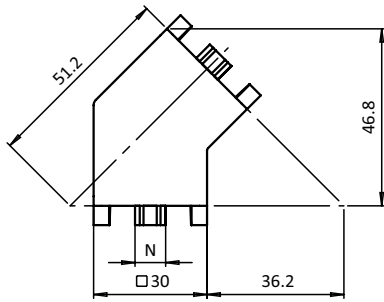

Winkelverbinder 30, 45° Angle Connector 30, 45°	Abdeckkappe Cover Cap	Montageset	Nut Slot	Gewicht [g] Weight [g]	Teil-Nr Part#
blank <i>Plain</i>	schwarz <i>Black</i>		- / 8 / 10	45.0	093WS30145N0810RS02
	schwarz <i>Black</i>	inkl. Montageset <i>incl. assembly set</i>	- / 8 / 10	95.0	093WS30145N0810RS01
alufarbig <i>Alu color</i>	schwarz <i>Black</i>		- / 8 / 10	45.0	093WS30145N0810S02
	alufarbig <i>Alu color</i>		- / 8 / 10	47.0	093WS30145N0810S03
	schwarz <i>Black</i>	inkl. Montageset <i>incl. assembly set</i>	- / 8 / 10	95.0	093WS30145N0810S01
	alufarbig <i>Alu color</i>	inkl. Montageset <i>incl. assembly set</i>	- / 8 / 10	96.5	093WS30145N0810S04



WINKELVERBINDER 45, 45°

ANGLE CONNECTOR 45, 45°

Ausführung	Aluminiumdruckguss	Model	Aluminum die-cast
Beschreibung	zur einfachen Verbindung von zwei Aluminiumprofilen im 45° Winkel	Description	To connect two aluminum profiles at 45°
Material	Winkelverbinder: Aluminiumdruckguss Abdeckkappen: Kunststoff PA, glasfaserverstärkt Montageset: Stahl	Material	Angle connector: Aluminum die-cast Cover caps: Plastic PA Assembly set: Steel
Liefereinheit	10 Stück	Pack Quantity	10 pieces

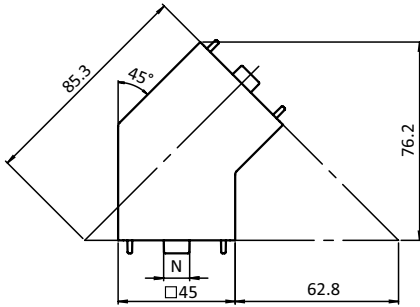

Winkelverbinder 45, 45° Angle Connector 45, 45°	Abdeckkappe Cover Cap	Montageset	Nut 10 Slot 10	Gewicht [g] Weight [g]	Teil-Nr Part#
blank <i>Plain</i>	schwarz <i>Black</i>		10	155.0	093WS45145N10RS01R02
	schwarz <i>Black</i>	inkl. Montageset <i>incl. assembly set</i>	10	228.0	093WS45145N10RS01
alufarbig <i>Alu color</i>	schwarz <i>Black</i>		10	155.0	093WS45145N10S01R02
	alufarbig <i>Alu color</i>		10	157.0	093WS45145N10S02R02
	schwarz <i>Black</i>	inkl. Montageset <i>incl. assembly set</i>	10	228.0	093WS45145N10S01
	alufarbig <i>Alu color</i>	inkl. Montageset <i>incl. assembly set</i>	10	231.0	093WS45145N10S02

4

SPANNVERBINDER 45°

CLAMP CONNECTOR 45°

Ausführung	Aluminium	Model	Aluminum
Beschreibung	zur Verbindung von zwei Aluminiumprofilen, zur Montage muss das Profil nicht bearbeitet werden	Description	To connect two aluminum profiles, no mechanical preparation needed
Material	Aluminium	Material	Aluminum
Liefereinheit	1 Stück	Pack Quantity	1 piece

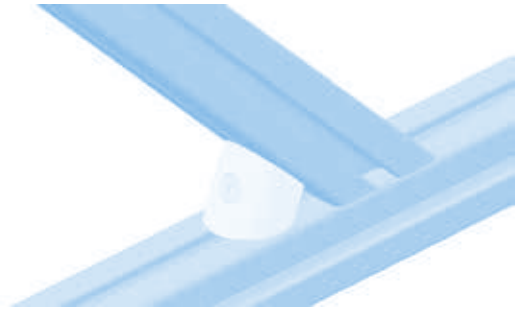
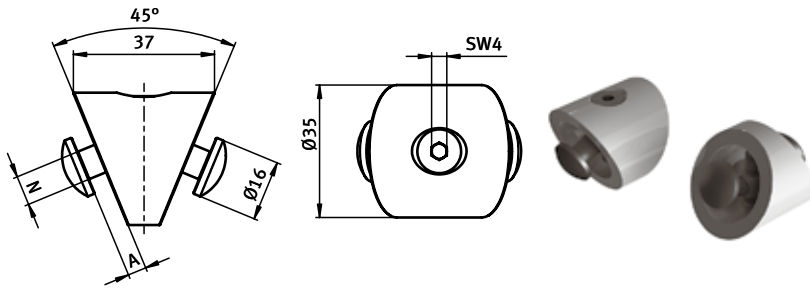

Spannverbinder 45°
Clamp connector 45°

Gewicht [g]
Weight [g]

Teil-Nr.
Part #

65

099SV45

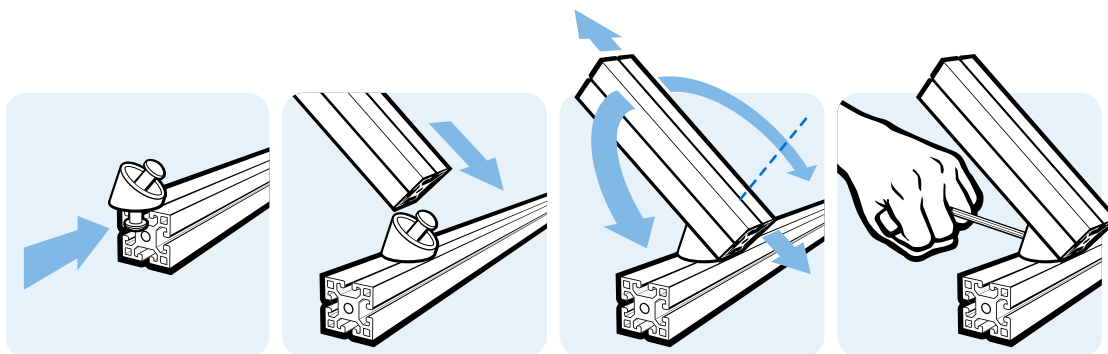



GELENK 20

PIVOT JOINT 20

Ausführung mit einstellbarer Friktion, Aluminiumdruckguss

Model With adjustable friction, die-cast aluminum

Beschreibung zur beweglichen Verbindung von zwei Profilen oder Flächenelementen, mit separaten Nutfixierungen für Nut 5 und Nut 6; mittels der Schrauben kann der Reibungswiderstand des Gelenkes stufenlos reguliert, bzw. das Gelenk in einer definierten Position fixiert werden

Description To make a pivoting connection between two profiles or panels; with separate locating pins for slot 5 and slot 6; by tightening or loosening the screws you can seamlessly regulate the functionality of the joint or you can fix it in one position

Material Aluminiumdruckguss

Material Aluminum die-cast

Liefereinheit 10 Stück

Pack Quantity 10 pieces

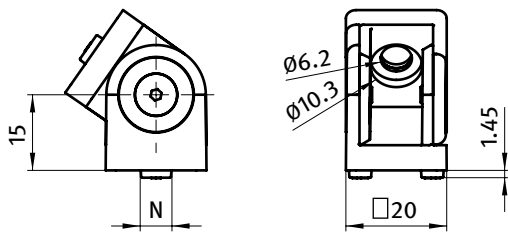

Gelenk 20
Pivot Joint 20

N

Öffnungswinkel
Opening Angle

Gewicht [g]
Weight [g]

Teil-Nr.
Part #

- / 5 / 6

190°

18.0

093GA20AN

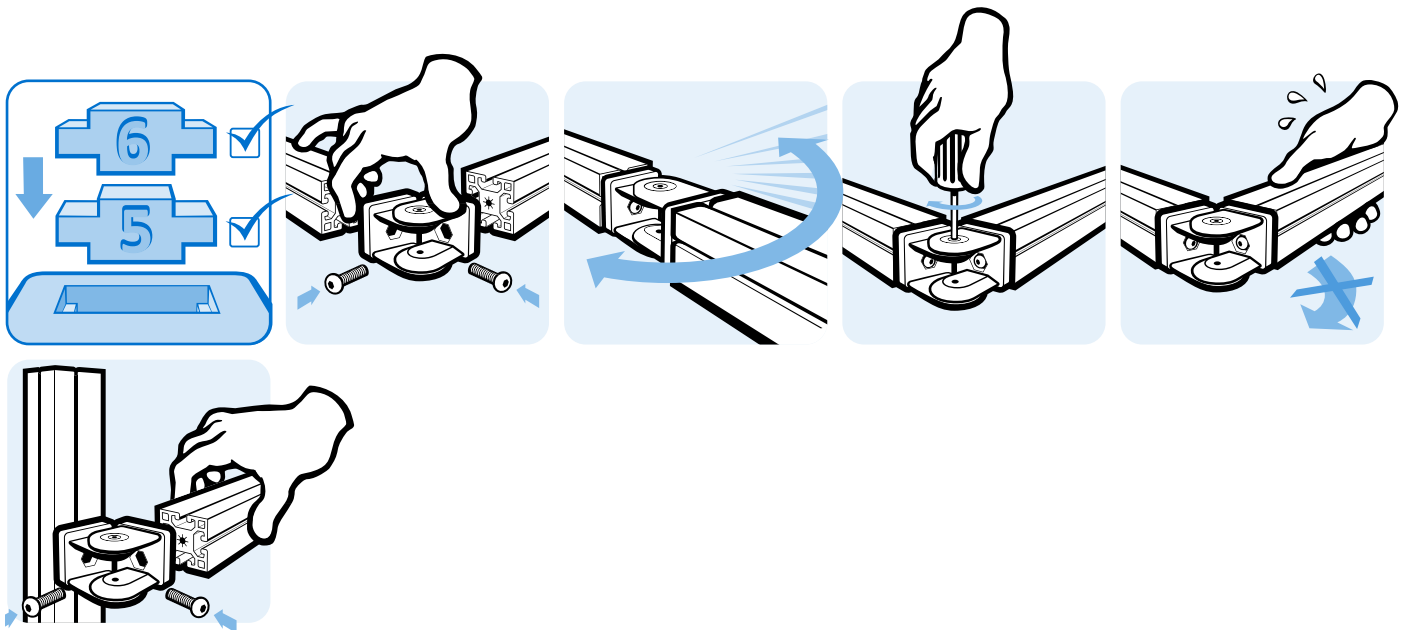



GELENK 20 MIT KLEMMHEBEL

PIVOT JOINT 20 WITH LOCKING LEVER

<p>Ausführung Aluminiumdruckguss</p> <p>Beschreibung zur Verbindung von zwei Profilen oder Flächenelementen, in beliebigen Winkeln fixierbar, mit separaten Nutfixierungen für Nut 5 oder Nut 6; mittels der Schrauben und des \mathcal{K}_{FPP}-Klemmhebels kann der Reibungswiderstand des Gelenkes stufenlos reguliert, bzw. das Gelenk in einer definierten Position fixiert werden</p> <p>Material Gelenk: Aluminiumdruckguss \mathcal{K}_{FPP}-Klemmhebel: Kunststoff PA, glasfaserverstärkt</p> <p>Liefereinheit 10 Stück</p>	<p>Model Aluminum die-cast</p> <p>Description For connection of two profiles or panels, with attachment at any angle, with separate slot fixing for slot 5 and slot 6; by tightening or loosening the screws and the \mathcal{K}_{FPP}-locking lever you can seamlessly regulate the functionality of the joint or you can fix it in one position</p> <p>Material Joint: Aluminum die-cast \mathcal{K}_{FPP}-locking lever: Plastic PA, glass fiber reinforced</p> <p>Pack Quantity 10 pieces</p>
--	---

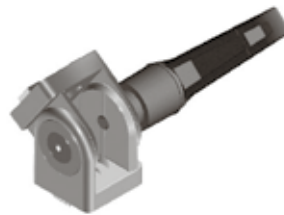
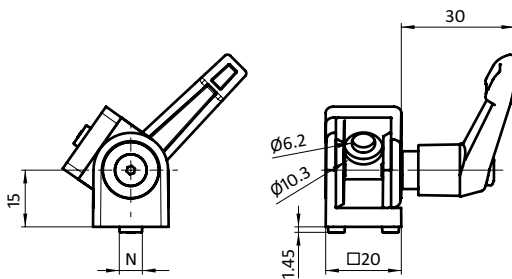

Gelenk 20 mit Klemmhebel <i>Pivot Joint 20 with Locking Lever</i>	N	Öffnungswinkel <i>Opening Angle</i>	Gewicht [g] <i>Weight [g]</i>	Teil-Nr. <i>Part #</i>
	- / 5 / 6	182°	25.0	093GAF20AN

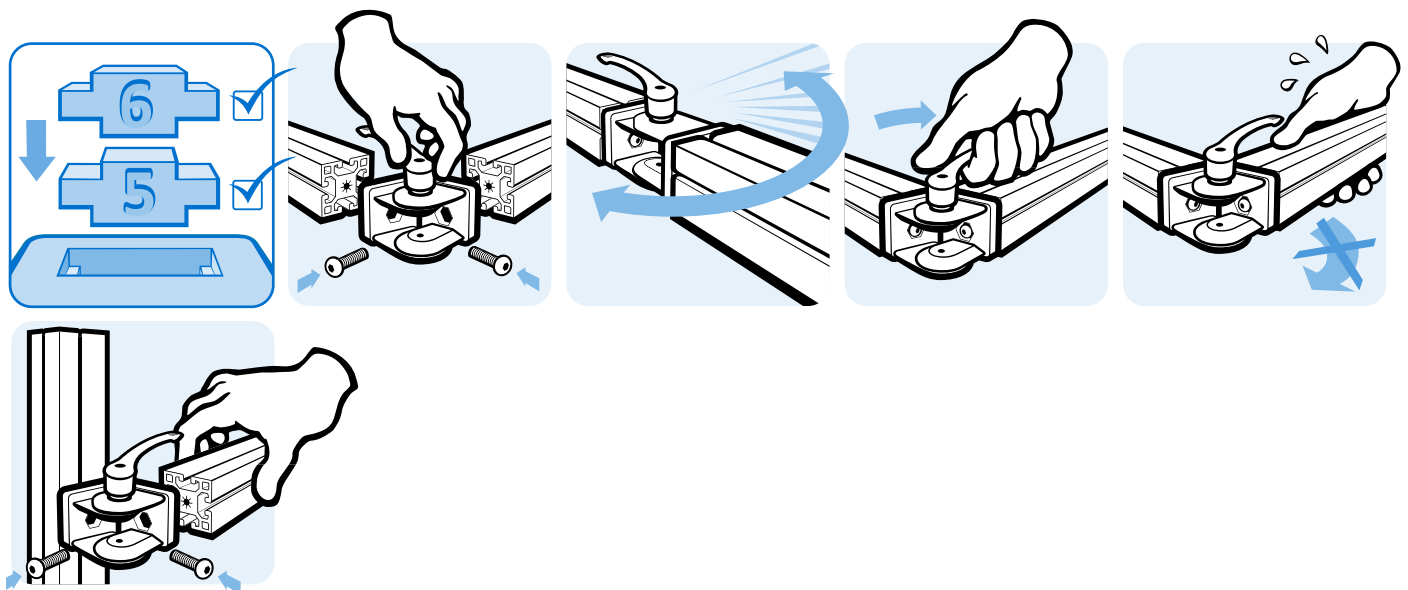



GELENK B 20

PIVOT JOINT B 20

Ausführung Lagerblock, mit einstellbarer Friktion, Aluminiumdruckguss

Model Bearing block, with adjustable friction, die-cast aluminum

Beschreibung zur Verbindung von zwei Profilen oder Flächenelementen, in beliebigen Winkeln fixierbar, auch mit Führungsnasen für Nut 5 oder Nut 6; mittels der Schrauben kann der Reibungswiderstand des Gelenkes stufenlos reguliert, bzw. das Gelenk in einer definierten Position fixiert werden

Description For connection of two profiles or panels, with attachment at any angle, fixed locating pins for slot 5 or 6 optional; by tightening or loosening the screws you can adjust the frictional resistance of the joint continuously, or you can fix it at a defined position; thicker walls for stronger locking

Material Aluminiumdruckguss

Material Die-cast aluminum

Oberfläche alufarbig lackiert

Surface Alu color laquered

Liefereinheit 10 Stück

Pack Quantity 10 pieces

Extras weitere Oberflächen, weitere Farben auf Anfrage

Specials Other surfaces, other colors on request

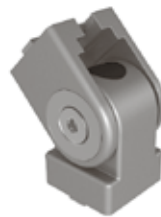
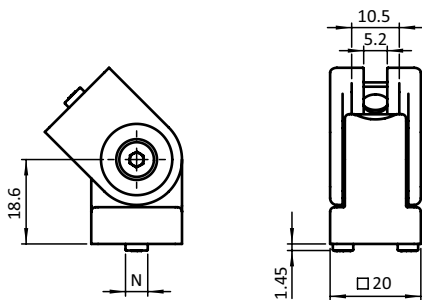

Gelenk B 20
Pivot Joint B 20

N

Öffnungswinkel
Opening Angle

Gewicht [g]
Weight [g]

Profil
Profile

Teil-Nr.
Part #

5

185°

33.0

I

093GAB20AN05

6

185°

33.0

B

093GAB20AN06

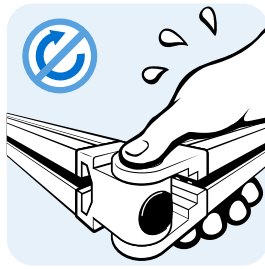
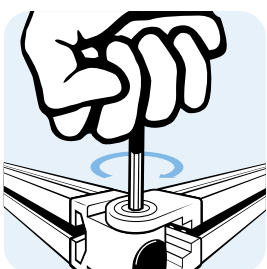
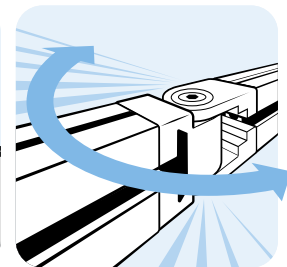
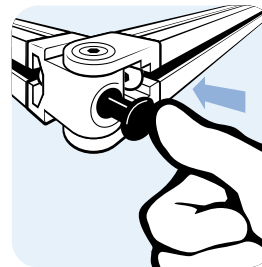
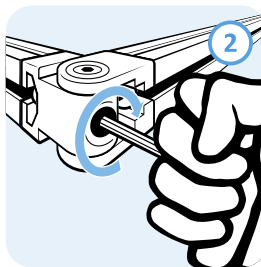
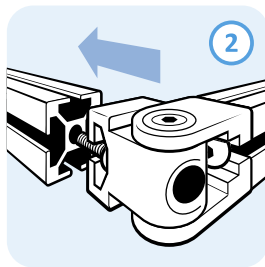
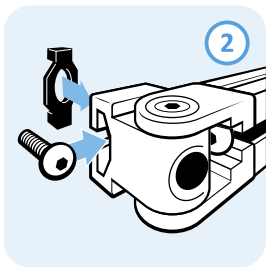
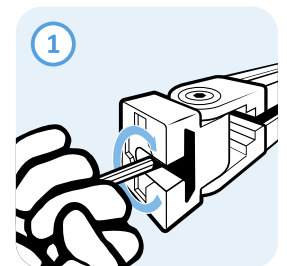
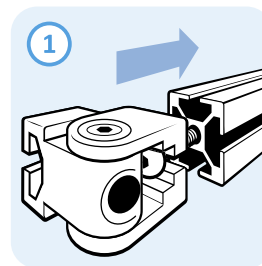
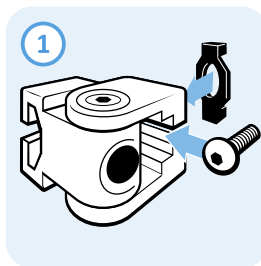
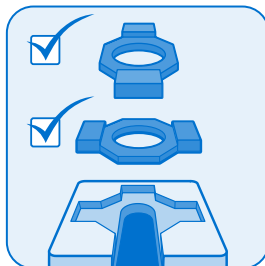
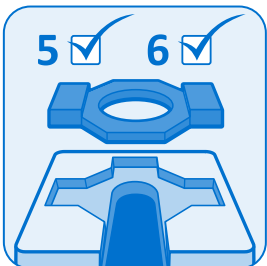



Gelenk B 20 MIT KLEMMHEBEL

PIVOT JOINT B 20 WITH LOCKING LEVER

Ausführung	Lagerblock, mit einstellbarer Friktion, Aluminiumdruckguss	Model	Bearing block, with adjustable friction, die-cast aluminum
Beschreibung	zur Verbindung von zwei Profilen oder Flächenelementen, in beliebigen Winkeln fixierbar, auch mit Führungsnasen für Nut 5 oder Nut 6; mittels der Schrauben und des -Klemmhebels kann der Reibungswiderstand des Gelenkes stufenlos reguliert, bzw. das Gelenk in einer definierten Position fixiert werden	Description	For connection of two profiles or panels, with attachment at any angle, fixed locating pins for slot 5 or 6 optional; by tightening or loosening the screws and the -locking lever you can adjust the frictional resistance of the joint continuously, or you can fix it at a defined position; thicker walls for stronger locking
Material	Gelenk: Aluminiumdruckguss -Klemmhebel: Kunststoff PA, glasfaserverstärkt	Material	Joint: Die-cast aluminum -locking lever: Plastics PA, glass fiber reinforced
Oberfläche	alufarbig lackiert	Surface	Alu color laquered
Liefereinheit	10 Stück	Pack Quantity	10 pieces
Extras	weitere Oberflächen, weitere Farben auf Anfrage	Specials	Other surfaces, other colors on request
Hinweis	die Schraube der Gelenkgabel muss zuerst in der geraden Position des Gelenkes durch die Bohrung im Lagerblock befestigt werden	Tip	Screw of the pivot joint fork must be mounted first in the straight position of the joint through the hole in the bearing block

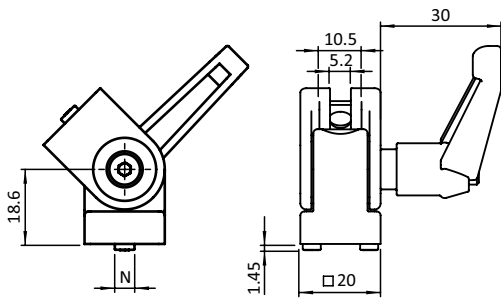

Gelenk B 20 mit Klemmhebel Pivot Joint B 20 with Locking lever	N	Öffnungswinkel Opening Angle	Gewicht [g] Weight [g]	Profil Profile	Teil-Nr. Part #
	5	185°	47.0	I	093GABF20AN05
	6	185°	47.0	B	093GABF20AN06

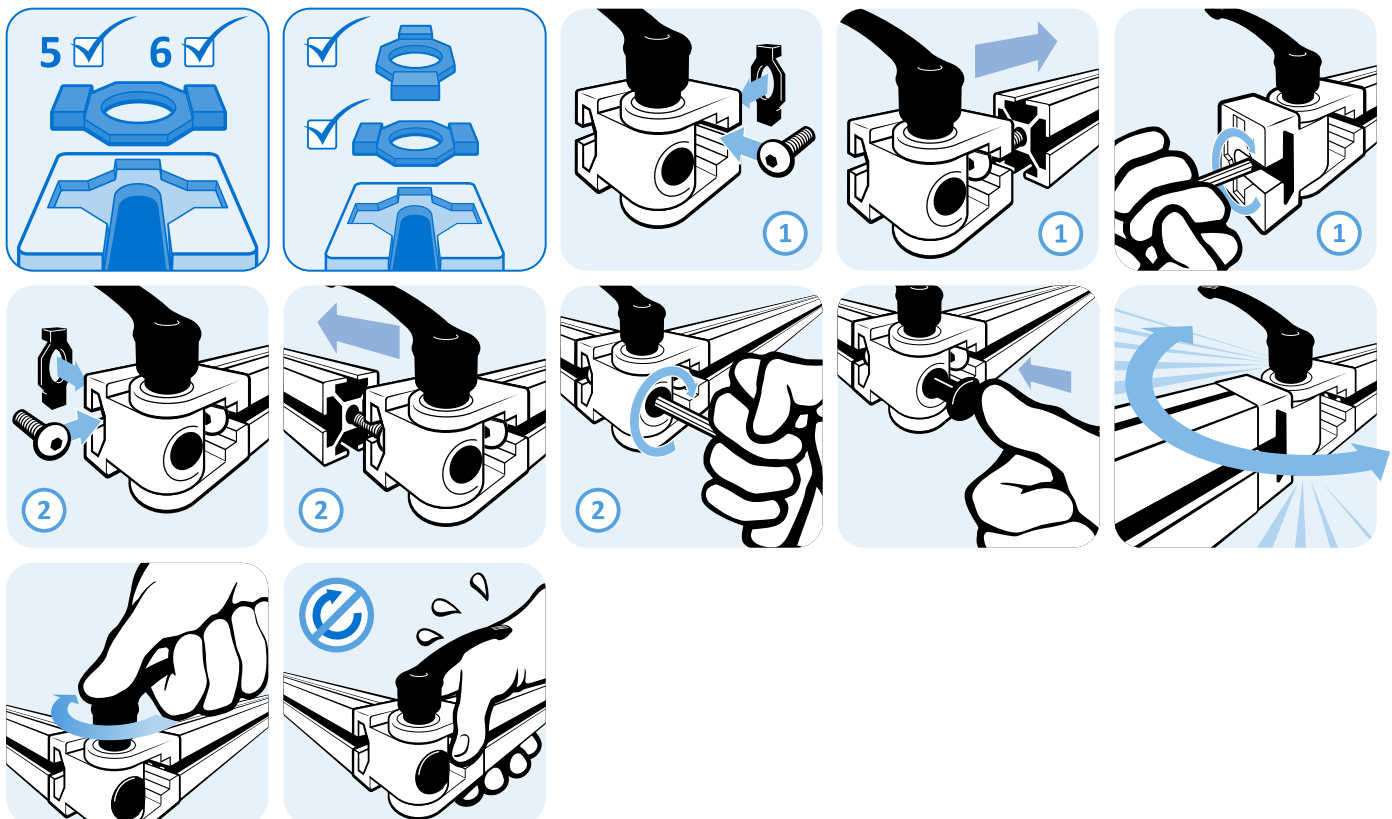



GELENK 20/40

PIVOT JOINT 20/40

Ausführung	mit einstellbarer Friktion, Aluminiumdruckguss	Model	With adjustable friction, die-cast aluminum
Beschreibung	zur beweglichen Verbindung von zwei Profilen oder Flächenelementen, mit separaten Nutfixierungen für Nut 5 und Nut 6; mittels der Schrauben kann der Reibungswiderstand des Gelenkes stufenlos reguliert, bzw. das Gelenk in einer definierten Position fixiert werden	Description	To make a pivoting connection between two profiles or panels; with separate locating pins for slot 5 and 6; by tightening or loosening the screws you can seamlessly regulate the functionality of the joint or you can fix it in one position
Material	Aluminiumdruckguss	Material	Aluminum die-cast
Oberfläche	alufarbig lackiert	Surface	Alu color laquered
Liefereinheit	10 Stück	Pack Quantity	10 pieces
Extras	weitere Oberflächen, weitere Farben auf Anfrage	Specials	Other surfaces, other colors on request

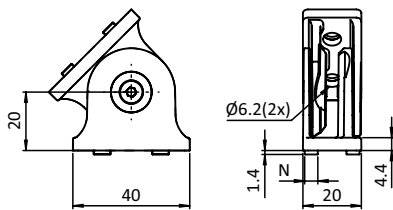

Gelenk 20/40 Pivot Joint 20/40	N	Öffnungswinkel Opening Angle	Gewicht [g] Weight [g]	Teil-Nr. Part #
	-	154°	43.5	093GA2040A
	5	154°	44.5	093GA2040AN05
	6	154°	44.5	093GA2040AN06

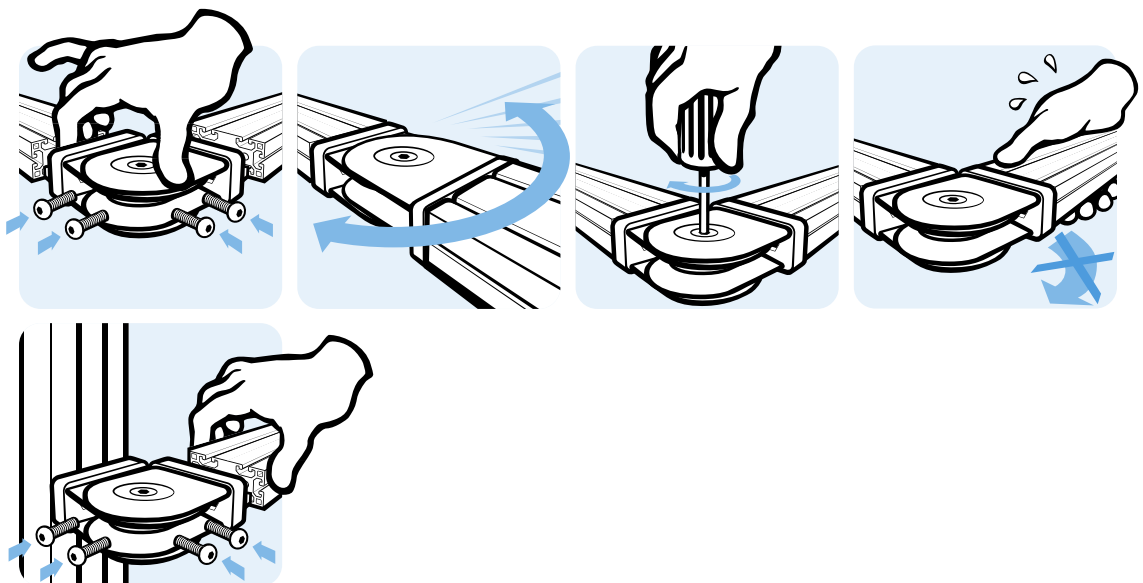



Gelenk 20 x 40 MIT KLEMMHEBEL

PIVOT JOINT 20 x 40 WITH LOCKING LEVER

<p>Ausführung Aluminiumdruckguss</p> <p>Beschreibung zur Verbindung von zwei Profilen oder Flächenelementen, in beliebigen Winkeln fixierbar, mit separaten Nutfixierungen für Nut 5 oder Nut 6; mittels der Schrauben und des M_{KPP}-Klemmhebels kann der Reibungswiderstand des Gelenkes stufenlos reguliert, bzw. das Gelenk in einer definierten Position fixiert werden</p> <p>Material Gelenk: Aluminiumdruckguss M_{KPP}-Klemmhebel: Kunststoff PA, glasfaserverstärkt</p> <p>Oberfläche alufarbig lackiert</p> <p>Liefereinheit 10 Stück</p> <p>Extras weitere Oberflächen, weitere Farben auf Anfrage</p>	<p>Model Die-cast aluminum</p> <p>Description For connection of two profiles or panels, with attachment at any angle, with separate slot fixing for slot 5 and slot 6; by tightening or loosening the screws and the M_{KPP}-locking lever you can adjust the frictional resistance of the joint continuously, or you can fix it at a defined position</p> <p>Material Joint: Die-cast aluminum M_{KPP}-locking lever: Plastics PA, glass fiber reinforced</p> <p>Surface Alu color laquered</p> <p>Pack Quantity 10 pieces</p> <p>Specials Other surfaces, other colors on request</p>
---	---

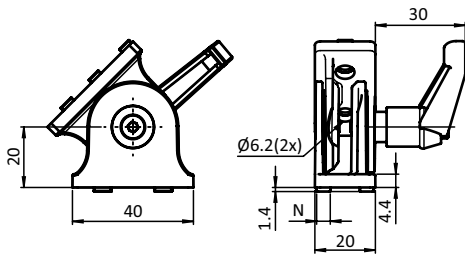

Gelenk 20 x 40 mit Klemmhebel <i>Pivot Joint 20 x 40 with Locking Lever</i>	N	Öffnungswinkel <i>Opening Angle</i>	Gewicht [g] <i>Weight [g]</i>	Teil-Nr. <i>Part #</i>
	–	154°	50.8	093GAF2040A
	5	154°	51.8	093GAF2040AN05
	6	154°	51.8	093GAF2040AN06

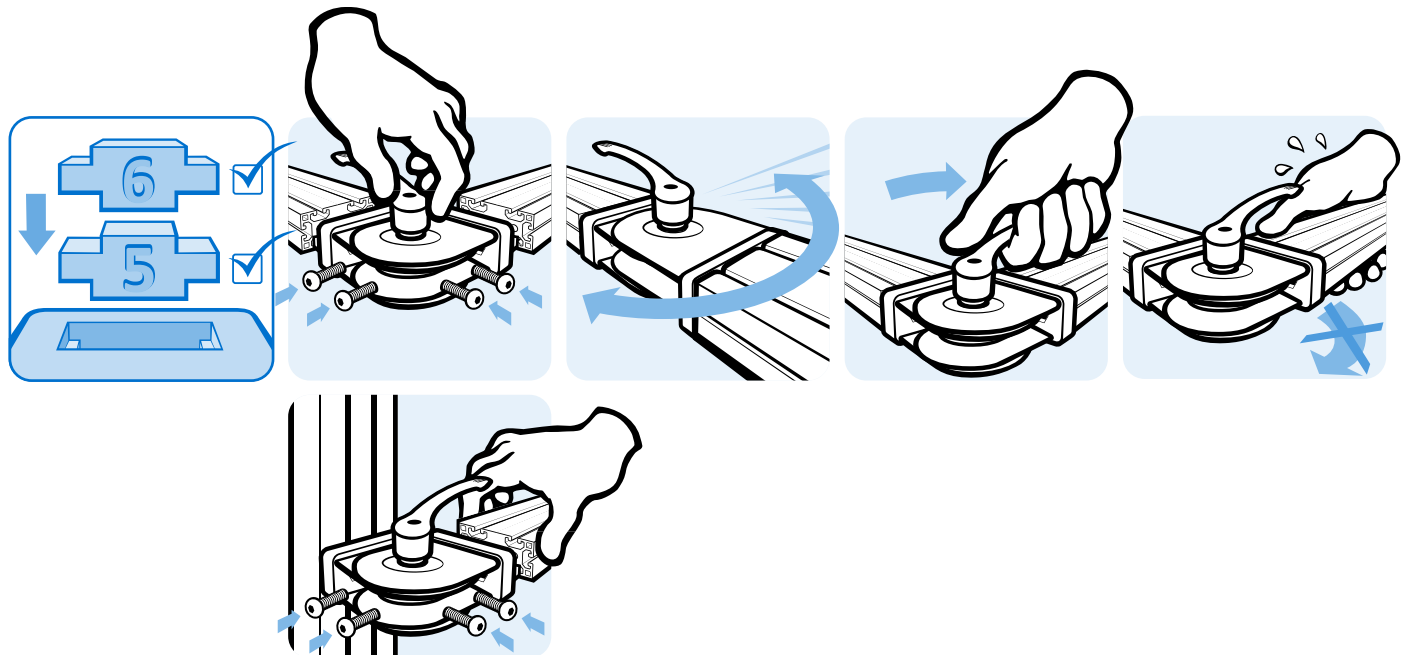



GELENK 25 - 1"

PIVOT JOINT 25 - 1"

Ausführung mit einstellbarer Friktion, Zinkdruckguss
Beschreibung zur beweglichen Verbindung von zwei Profilen oder Flächenelementen, mit oder ohne Führungsnasen für Nut 6; mittels der Schrauben kann der Reibungswiderstand des Gelenkes stufenlos reguliert, bzw. das Gelenk in einer definierten Position fixiert werden
Material Zinkdruckguss
Liefereinheit 10 Stück
Extras weitere Oberflächen, weitere Farben auf Anfrage

Model With adjustable friction, zinc die-cast
Description To make a pivoting connection between two profiles or panels; fixed locating pins for slot 6 optional; by tightening or loosening the screws you can seamlessly regulate the functionality of the joint or you can fix it in one position
Material Zinc die-cast
Pack Quantity 10 pieces
Specials Other surfaces, other colors on request

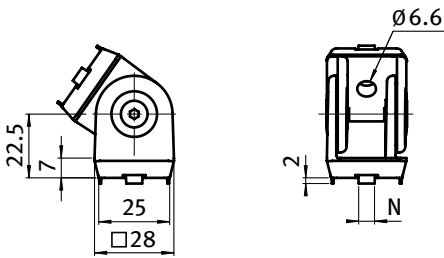

Gelenk 25 - 1"
Pivot Joint 25 - 1"

N

Öffnungswinkel
Opening Angle

Gewicht [g]
Weight [g]

Teil-Nr.
Part #

	N	Öffnungswinkel Opening Angle	Gewicht [g] Weight [g]	Teil-Nr. Part #
		190°	116.0	093G25A
	6	190°	116.0	093G25AN06

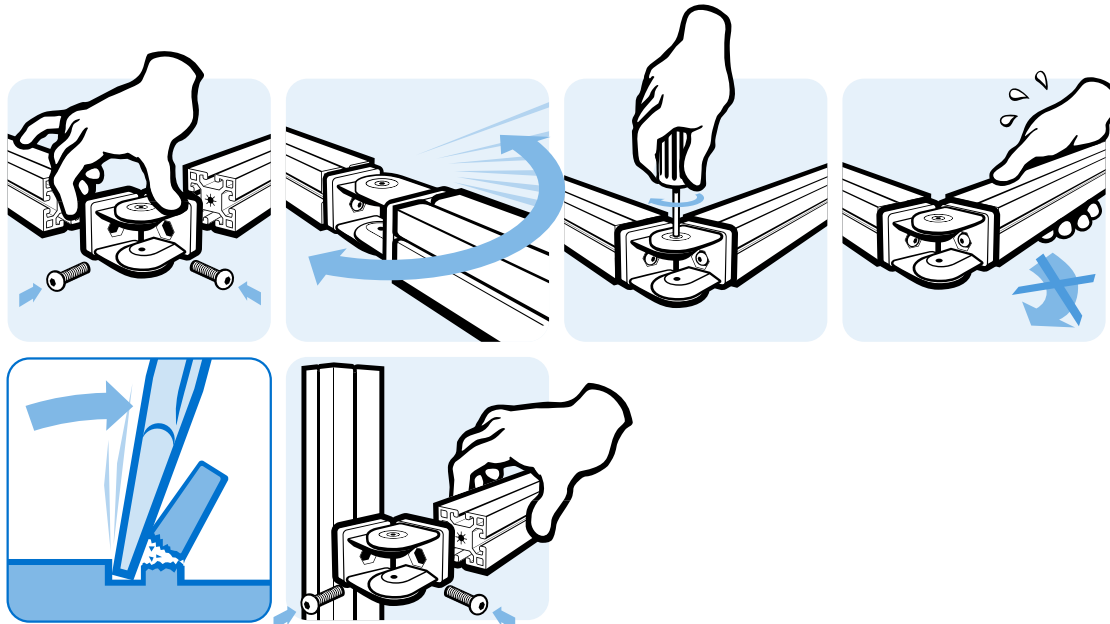



Gelenk 25 - 1" MIT KLEMMHEBEL

PIVOT JOINT 25 - 1" WITH LOCKING LEVER

Ausführung	Zinkdruckguss	Model	Zinc die-cast
Beschreibung	zur Verbindung von zwei Profilen oder Flächenelementen, in beliebigen Winkeln fixierbar, mit oder ohne Führungsnasen für Nut 6; mittels der Schrauben und des $\frac{1}{4}$ "-Klemmhebels kann der Reibungswiderstand des Gelenkes stufenlos reguliert, bzw. das Gelenk in einer definierten Position fixiert werden	Description	To make a pivoting connection between 2 profiles or panels which can be fixed at any angle; fixed locating pins for slot 6 optional; by tightening or loosening the screws and the $\frac{1}{4}$ "-locking lever you can seamlessly regulate the functionality of the joint or you can fix it in one position
Material	Gelenk: Zinkdruckguss $\frac{1}{4}$ "-Klemmhebel: Kunststoff PA, glasfaserverstärkt	Material	Joint: Zinc die-cast $\frac{1}{4}$ "-locking lever: Plastic PA, glass fiber reinforced
Liefereinheit	10 Stück	Pack Quantity	10 pieces
Extras	weitere Oberflächen, weitere Farben auf Anfrage	Specials	Other surfaces, other colors on request



Gelenk 25 - 1" mit Klemmhebel <i>Pivot Joint 25 - 1" with Locking Lever</i>	N	Öffnungswinkel <i>Opening Angle</i>	Gewicht [g] <i>Weight [g]</i>	Teil-Nr. <i>Part #</i>
		190°	138.0	093GF25A
	6	190°	138.0	093GF25AN06

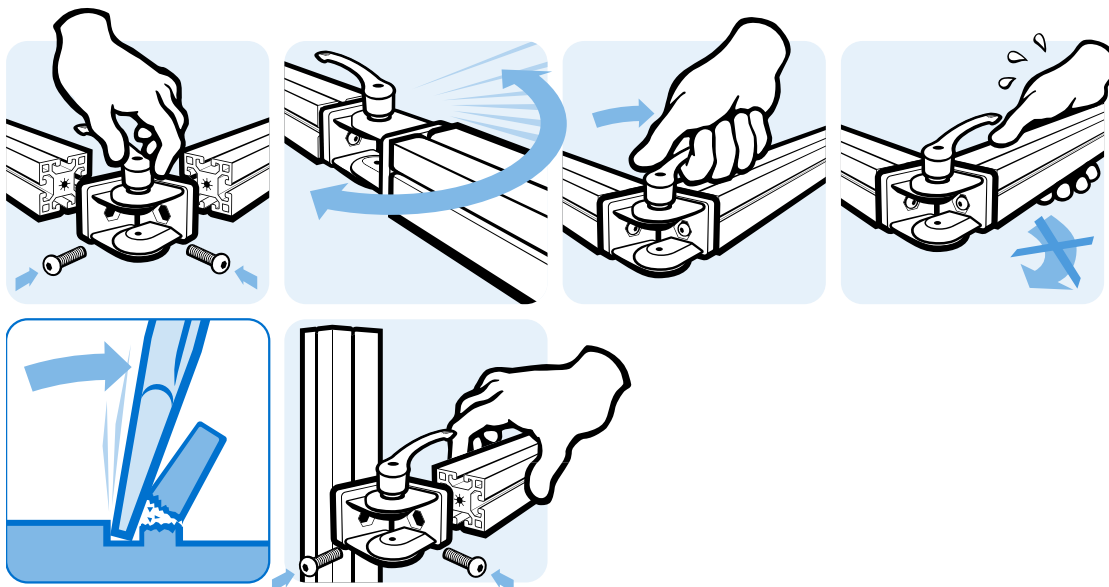



GELENK 28 - 1,1"

PIVOT JOINT 28 - 1.1"

Ausführung mit einstellbarer Friktion, Zinkdruckguss
Beschreibung zur beweglichen Verbindung von zwei Profilen oder Flächenelementen, mit oder ohne Führungsnasen für Nut 8; mittels der Schrauben kann der Reibungswiderstand des Gelenkes stufenlos reguliert, bzw. das Gelenk in einer definierten Position fixiert werden
Material Zinkdruckguss
Liefereinheit 10 Stück
Extras weitere Oberflächen, weitere Farben auf Anfrage

Model With adjustable friction, zinc die-cast
Description To make a pivoting connection between two profiles or panels; fixed locating pins for slot 8 optional; by tightening or loosening the screws you can seamlessly regulate the functionality of the joint or you can fix it in one position
Material Zinc die-cast
Pack Quantity 10 pieces
Specials Other surfaces, other colors on request

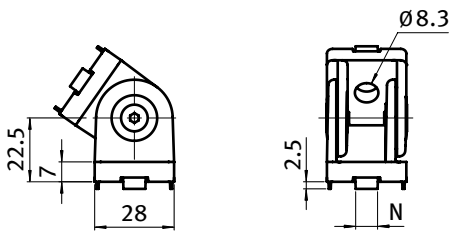

Gelenk 28 - 1,1"
Pivot Joint 28 - 1.1"

N

Öffnungswinkel
Opening Angle

Gewicht [g]
Weight [g]

Teil-Nr.
Part #

190°

128.0

093G28A

8

190°

128.0

093G28AN08

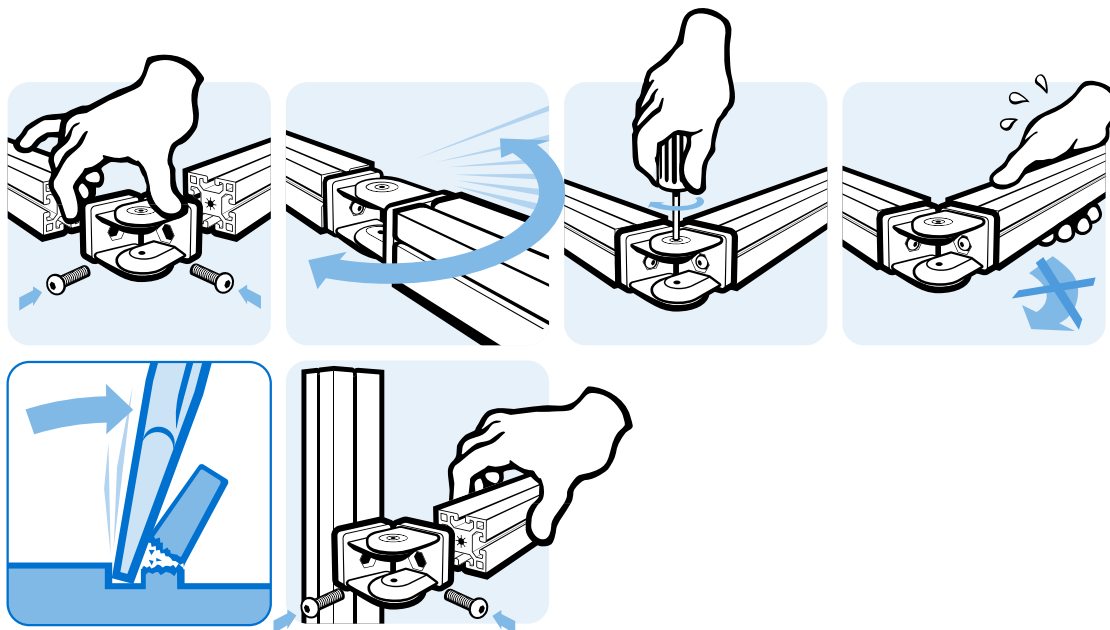



GELENK 28 - 1,1" MIT KLEMMHEBEL

PIVOT JOINT 28 - 1.1" WITH LOCKING LEVER

<p>Ausführung Zinkdruckguss</p> <p>Beschreibung zur Verbindung von zwei Profilen oder Flächenelementen, in beliebigen Winkeln fixierbar, mit oder ohne Führungsnasen für Nut 8; mittels der Schrauben und des -Klemmhebels kann der Reibungswiderstand des Gelenkes stufenlos reguliert, bzw. das Gelenk in einer definierten Position fixiert werden</p> <p>Material Gelenk: Zinkdruckguss -Klemmhebel: Kunststoff PA, glasfaserverstärkt</p> <p>Liefereinheit 10 Stück</p> <p>Extras weitere Oberflächen, weitere Farben auf Anfrage</p>	<p>Model Zinc die-cast</p> <p>Description To make a pivoting connection between two profiles or panels which can be fixed at any angle; fixed locating pins for slot 8 optional; by tightening or loosening the screws and the -locking lever you can seamlessly regulate the functionality of the joint or you can fix it in one position</p> <p>Material Joint: Zinc die-cast -locking lever: Plastic PA, glass fiber reinforced</p> <p>Pack Quantity 10 pieces</p> <p>Specials Other surfaces, other colors on request</p>
---	--



Gelenk 28 - 1,1" mit Klemmhebel <i>Pivot Joint 28 - 1.1" with Locking Lever</i>	N	Öffnungswinkel <i>Opening Angle</i>	Gewicht [g] <i>Weight [g]</i>	Teil-Nr. <i>Part #</i>
		190°	150.0	093GF28A
	8	190°	150.0	093GF28AN08

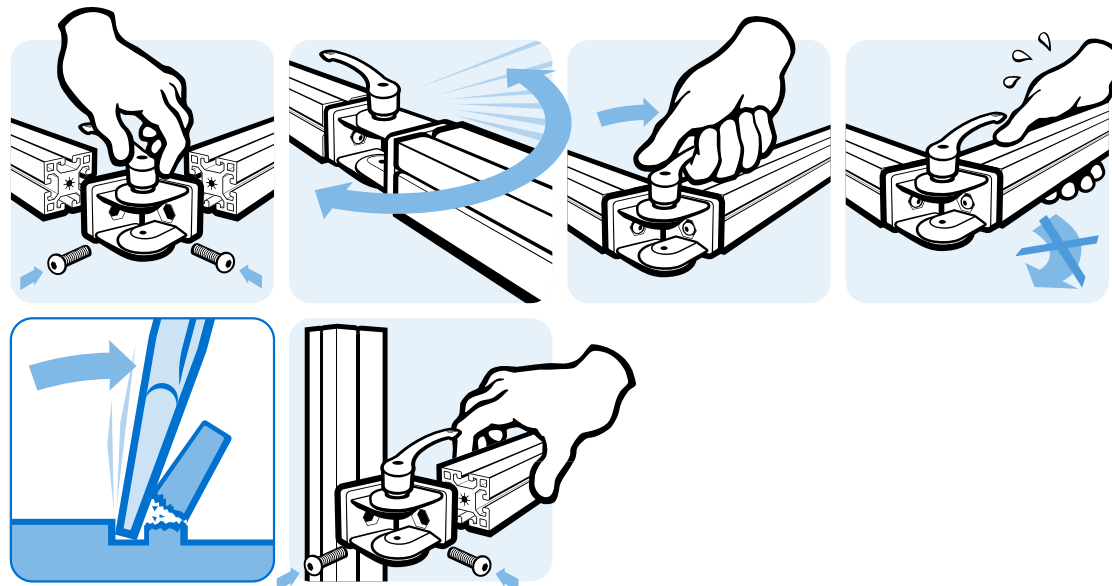



GELENK 30

PIVOT JOINT 30

Ausführung	mit einstellbarer Friktion, Zinkdruckguss	Model	With adjustable friction, zinc die-cast
Beschreibung	zur beweglichen Verbindung von zwei Profilen oder Flächenelementen, auch mit Führungsnasen für Nut 6 oder Nut 8; mittels der Schrauben kann der Reibungswiderstand des Gelenkes stufenlos reguliert, bzw. das Gelenk in einer definierten Position fixiert werden	Description	To make a pivoting connection between 2 profiles or panels, fixed locating pins for slot 6 or 8 optional; by tightening or loosening the screws you can seamlessly regulate the functionality of the joint or you can fix it in one position
Material	Zinkdruckguss	Material	Zinc die-cast
Liefereinheit	10 Stück	Pack Quantity	10 pieces
Extras	weitere Oberflächen, weitere Farben auf Anfrage	Specials	Other surfaces, other colors on request

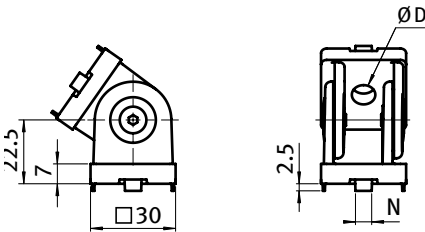

Gelenk 30 Pivot Joint 30	ØD [mm]	Nut Slot	Öffnungswinkel Opening Angle	Gewicht [g] Weight [g]	Teil-Nr. Part #
	8.3		183°	134.0	093G30A
	6.6	6	183°	136.0	093G30AN06
	8.3	8	183°	134.0	093G30AN08

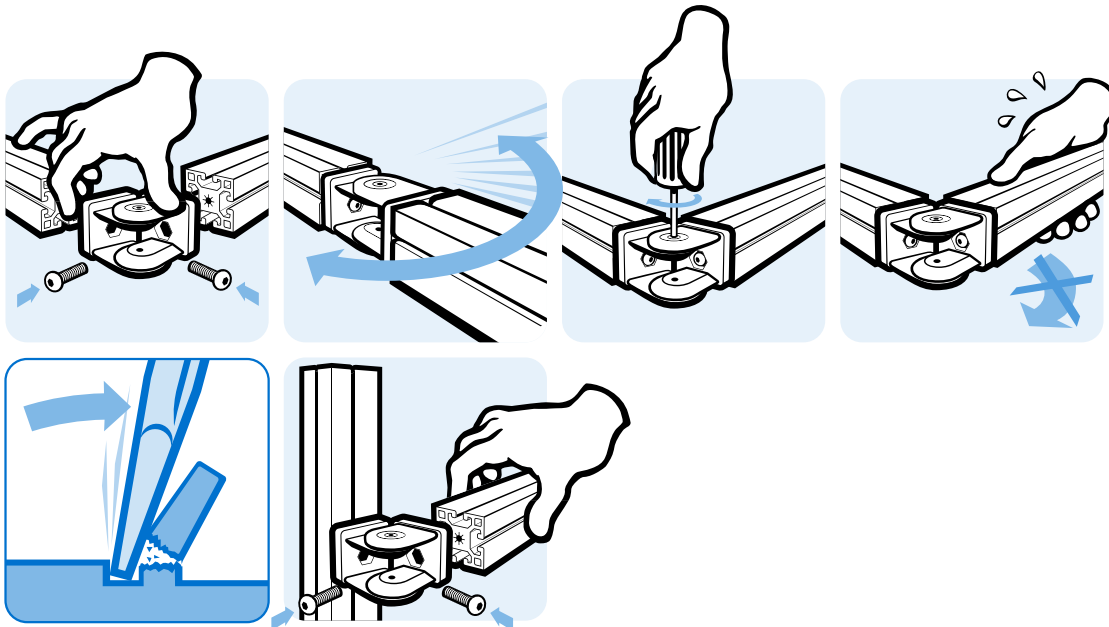



GELENK 30 MIT KLEMMHEBEL

PIVOT JOINT 30 WITH LOCKING LEVER

<p>Ausführung Zinkdruckguss</p> <p>Beschreibung zur Verbindung von zwei Profilen oder Flächenelementen, in beliebigen Winkeln fixierbar, auch mit Führungsnasen für Nut 6 oder Nut 8; mittels der Schrauben und des -Klemmhebels kann der Reibungswiderstand des Gelenkes stufenlos reguliert, bzw. das Gelenk in einer definierten Position fixiert werden</p> <p>Material Gelenk: Zinkdruckguss -Klemmhebel: Kunststoff PA, glasfaserverstärkt</p> <p>Liefereinheit 10 Stück</p> <p>Extras weitere Oberflächen, weitere Farben auf Anfrage</p>	<p>Model Zinc die-cast</p> <p>Description To make a pivoting connection between 2 profiles or panels which can be fixed at any angle; fixed locating pins for slot 6 or 8 optional; by tightening or loosening the screws and the -locking lever you can seamlessly regulate the functionality of the joint or you can fix it in one position</p> <p>Material Joint: Zinc die-cast -locking lever: Plastic PA, glass fiber reinforced</p> <p>Pack Quantity 10 pieces</p> <p>Specials Other surfaces, other colors on request</p>
---	---



Gelenk 30 mit Klemmhebel <i>Pivot Joint 30 with Locking Lever</i>	ØD [mm]	Nut Slot	Öffnungswinkel Opening Angle	Gewicht [g] Weight [g]	Teil-Nr. Part #
	8.3		182°	156.0	093GF30A
	6.6	6	182°	158.0	093GF30AN06
	8.3	8	182°	156.0	093GF30AN08

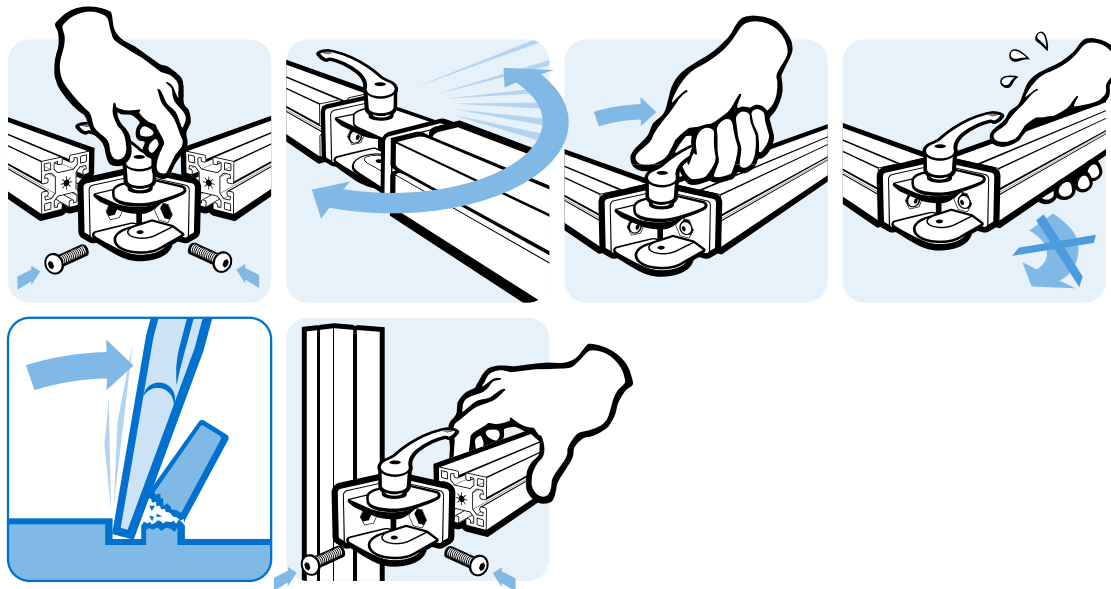



GELENK 30 x 60

PIVOT JOINT 30 x 60

Ausführung mit einstellbarer Friktion, Aluminiumdruckguss
Beschreibung zur beweglichen Verbindung von zwei Profilen oder Flächenelementen, mit separaten Nutfixierungen für Nut 6 und Nut 8; mittels der Schrauben kann der Reibungswiderstand des Gelenkes stufenlos reguliert, bzw. das Gelenk in einer definierten Position fixiert werden
Material Aluminiumdruckguss
Oberfläche alufarbig lackiert
Extras weitere Oberflächen, weitere Farben auf Anfrage
Liefereinheit 10 Stück

Model With adjustable friction, die-cast aluminum
Description To make a pivoting connection between two profiles or panels; with separate locating pins for slot 6 and 8; by tightening or loosening the screws you can seamlessly regulate the functionality of the joint or you can fix it in one position
Material Aluminum die-cast
Surface Alu color laquered
Specials Other surfaces, other colors on request
Pack Quantity 10 pieces

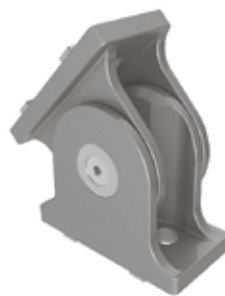
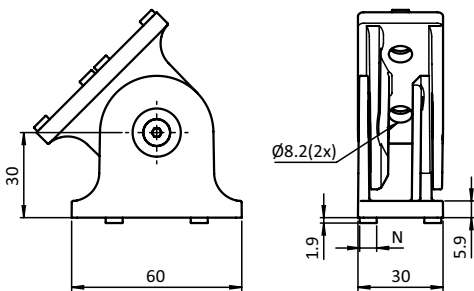

Gelenk 30 x 60
Pivot Joint 30 x 60

N	Öffnungswinkel Opening Angle	Gewicht [g] Weight [g]	Teil-Nr. Part #
-	158°	122.2	093GA3060A
6	158°	126.2	093GA3060AN06
8	158°	126.2	093GA3060AN08

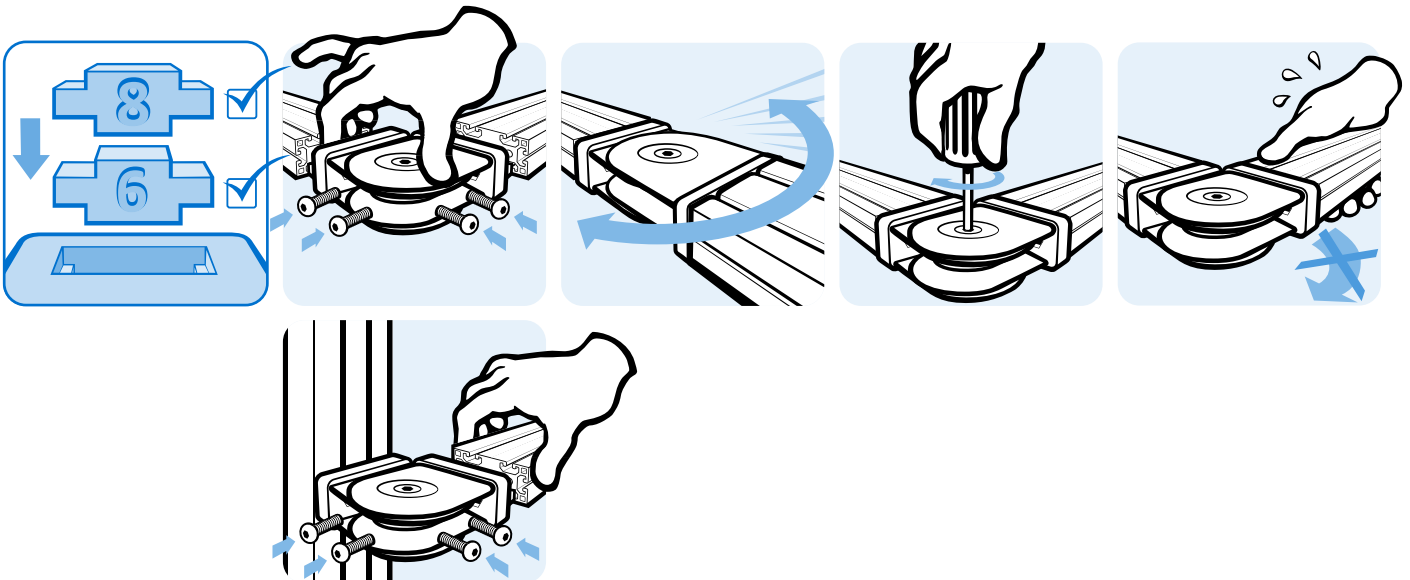



GELENK 30 × 60 MIT KLEMMHEBEL

PIVOT JOINT 30 × 60 WITH LOCKING LEVER

<p>Ausführung Aluminiumdruckguss</p> <p>Beschreibung zur Verbindung von zwei Profilen oder Flächenelementen, in beliebigen Winkeln fixierbar, mit separaten Nutfixierungen für Nut 6 oder Nut 8; mittels der Schrauben und des M_{Klemm}-Klemmhebels kann der Reibungswiderstand des Gelenkes stufenlos reguliert, bzw. das Gelenk in einer definierten Position fixiert werden</p> <p>Material Gelenk: Aluminiumdruckguss M_{Klemm}-Klemmhebel: Kunststoff PA, glasfaserverstärkt</p> <p>Farbe alufarbig lackiert</p> <p>Liefereinheit 10 Stück</p> <p>Extras weitere Oberflächen, weitere Farben auf Anfrage</p>	<p>Model Die-cast aluminum</p> <p>Description For connection of two profiles or panels, with attachment at any angle, with separate slot fixing for slot 6 and slot 8; by tightening or loosening the screws and the M_{Klemm}-locking lever you can adjust the frictional resistance of the joint continuously, or you can fix it at a defined position</p> <p>Material Joint: Die-cast aluminum M_{Klemm}-locking lever: Plastics PA, glass fiber reinforced</p> <p>Color Alu color laquered</p> <p>Pack Quantity 10 pieces</p> <p>Specials Other surfaces, other colors on request</p>
--	---

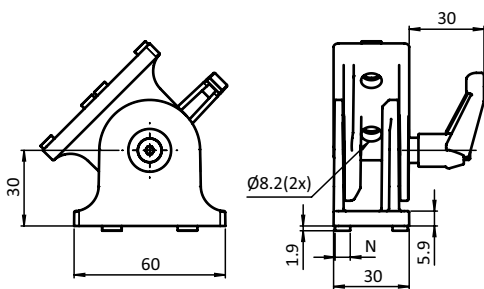

Gelenk 30 × 60 mit Klemmhebel
Pivot Joint 30 × 60 with Locking Lever

<i>N</i>	Öffnungswinkel <i>Opening Angle</i>	Gewicht [g] <i>Weight [g]</i>	Teil-Nr. <i>Part #</i>
–	158°	139.0	093GAF3060A
6	158°	143.0	093GAF3060AN06
8	158°	143.0	093GAF3060AN08

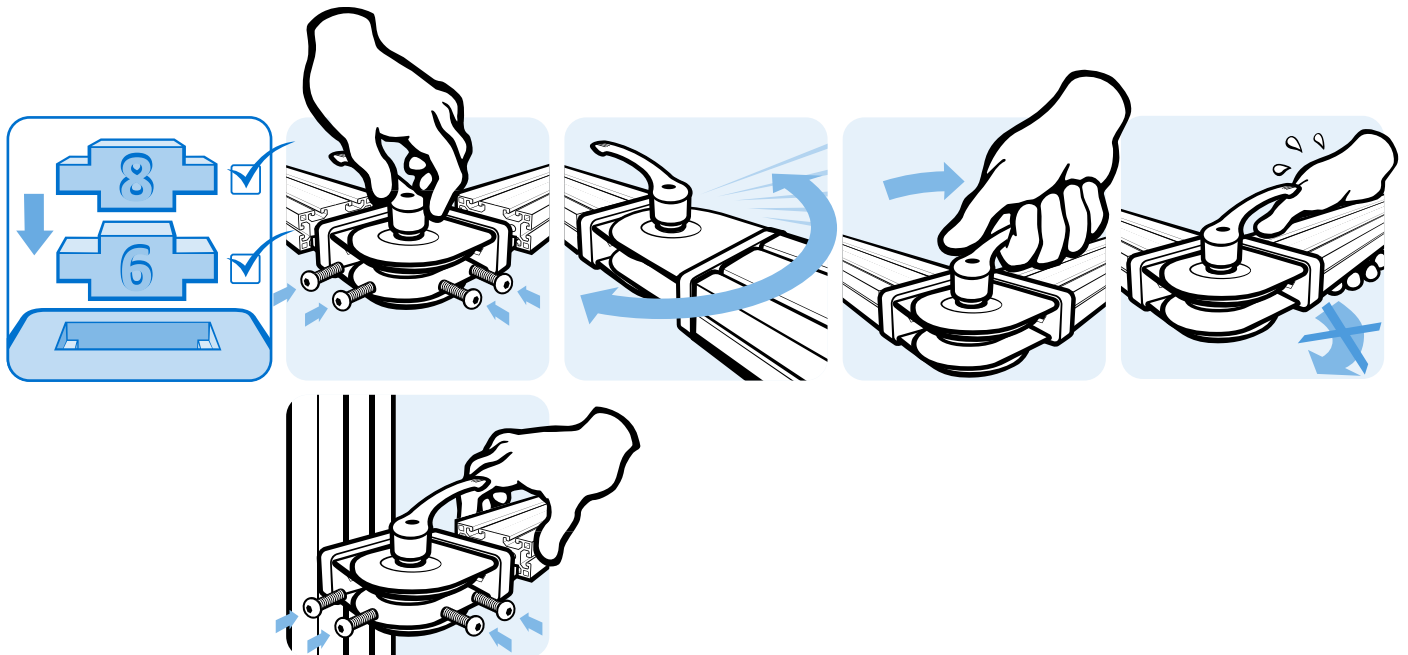



GELENK 38 - 1,5"

PIVOT JOINT 38 - 1.5"

Ausführung mit einstellbarer Friktion, Zinkdruckguss
Beschreibung zur beweglichen Verbindung von zwei Profilen oder Flächenelementen, mit separaten Nutfixierungen für Nut 8; mittels der Schrauben kann der Reibungswiderstand des Gelenkes stufenlos reguliert bzw. das Gelenk in einer definierten Position fixiert werden
Material Zinkdruckguss
Liefereinheit 10 Stück
Extras weitere Oberflächen, weitere Farben auf Anfrage

Model With adjustable friction, zinc die-cast
Description To make a pivoting connection between two profiles or panels; fixed locating pins for slot 8 optional; by tightening or loosening the screws you can seamlessly regulate the functionality of the joint or you can fix it in one position
Material Zinc die-cast
Pack Quantity 10 pieces
Specials Other surfaces, other colors on request

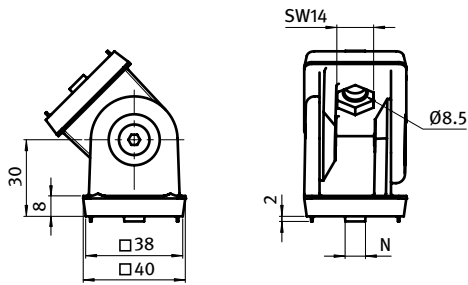

Gelenk 38 - 1,5"
Pivot Joint 38 - 1.5"

N

Öffnungswinkel
Opening Angle

Gewicht [g]
Weight [g]

Teil-Nr.
Part #

	N	Öffnungswinkel Opening Angle	Gewicht [g] Weight [g]	Teil-Nr. Part #
		190°	321.0	093G38A
	8	190°	321.0	093G38AN08

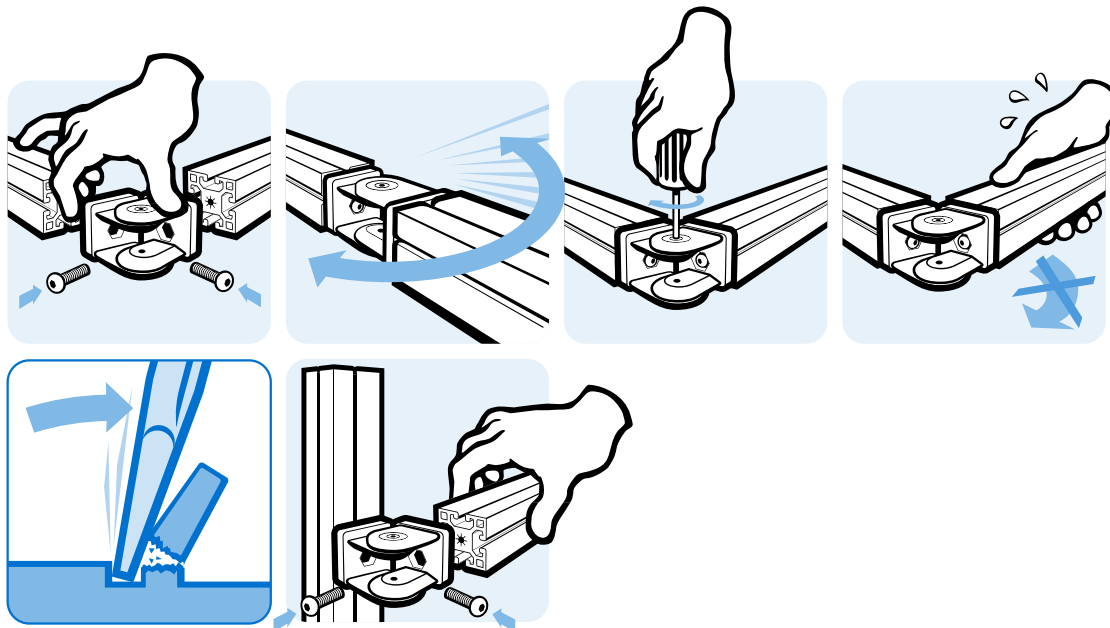



Gelenk 38 - 1,5" MIT KLEMMHEBEL

PIVOT JOINT 38 - 1.5" WITH LOCKING LEVER

<p>Ausführung Zinkdruckguss</p> <p>Beschreibung zur Verbindung von zwei Profilen oder Flächenelementen, in beliebigen Winkeln fixierbar, auch mit Führungsnasen für Nut 6 oder Nut 8; mittels der Schrauben und des -Klemmhebels kann der Reibungswiderstand des Gelenkes stufenlos reguliert, bzw. das Gelenk in einer definierten Position fixiert werden</p> <p>Material Gelenk: Zinkdruckguss -Klemmhebel: Kunststoff PA, glasfaserverstärkt</p> <p>Liefereinheit 10 Stück</p> <p>Extras weitere Oberflächen, weitere Farben auf Anfrage</p>	<p>Model Zinc die-cast</p> <p>Description To make a pivoting connection between 2 profiles or panels which can be fixed at any angle; fixed locating pins for slot 8 optional; by tightening or loosening the screws and the -locking lever you can seamlessly regulate the functionality of the joint or you can fix it in one position</p> <p>Material Joint: Zinc die-cast -locking lever: Plastic PA, glass fiber reinforced</p> <p>Pack Quantity 10 pieces</p> <p>Specials Other surfaces, other colors on request</p>
---	--

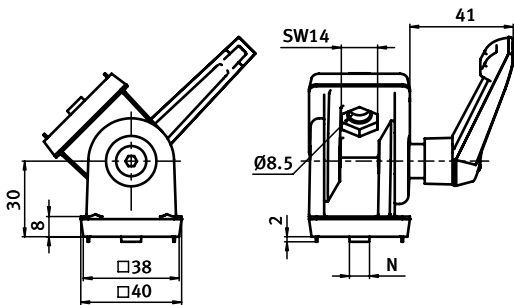

Gelenk 38 - 1,5" mit Klemmhebel
Pivot Joint 38 - 1.5" with Locking Lever

N

Öffnungswinkel
Opening Angle

Gewicht [g]
Weight [g]

Teil-Nr.
Part #

	190°	365.1	093GF38A
8	190°	365.1	093GF38AN08

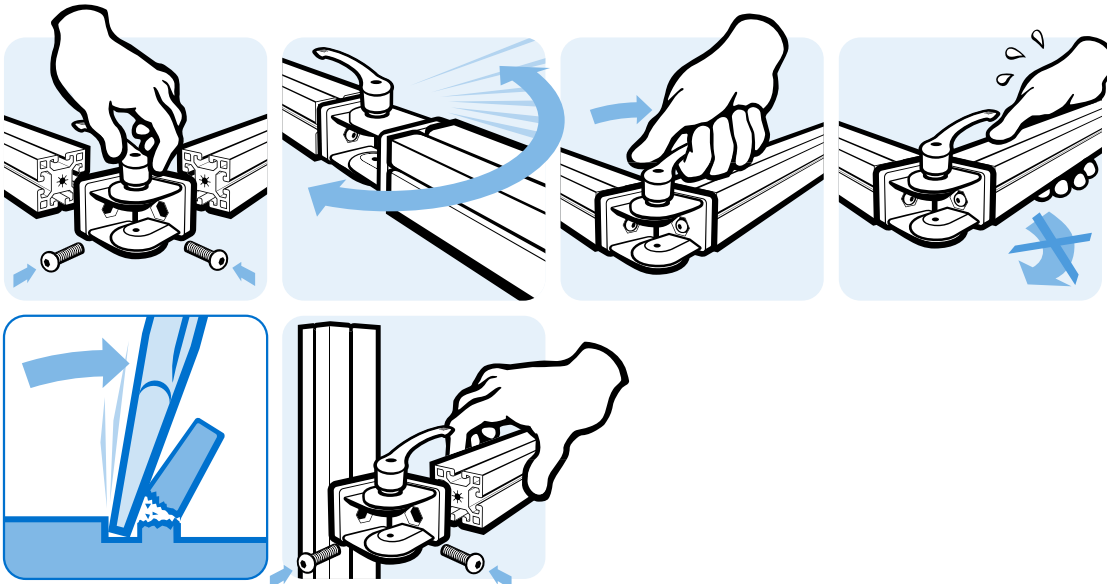



GELENK 38 x 76 - 1,5" x 3"

PIVOT JOINT 38 x 76 - 1.5" x 3"

<p>Ausführung mit einstellbarer Friktion, Zinkdruckguss</p> <p>Beschreibung zur beweglichen Verbindung von zwei Profilen oder Flächenelementen, mit separaten Nutfixierungen für Nut 8 und Nut 10; mittels der Schrauben kann der Reibungswiderstand des Gelenkes stufenlos reguliert, bzw. das Gelenk in einer definierten Position fixiert werden</p> <p>Material Zinkdruckguss</p> <p>Oberfläche alufarbig pulverbeschichtet</p> <p>Liefereinheit 10 Stück</p> <p>Extras weitere Oberflächen, weitere Farben auf Anfrage</p>	<p>Model With adjustable friction, zinc die-cast</p> <p>Description To make a pivoting connection between two profiles or panels; with separate locating pins for slot 8 and 10; by tightening or loosening the screws you can seamlessly regulate the functionality of the joint or you can fix it in one position</p> <p>Material Zinc die-cast</p> <p>Surface Alu color powder coated</p> <p>Pack Quantity 10 pieces</p> <p>Specials Other surfaces, other colors on request</p>
---	---

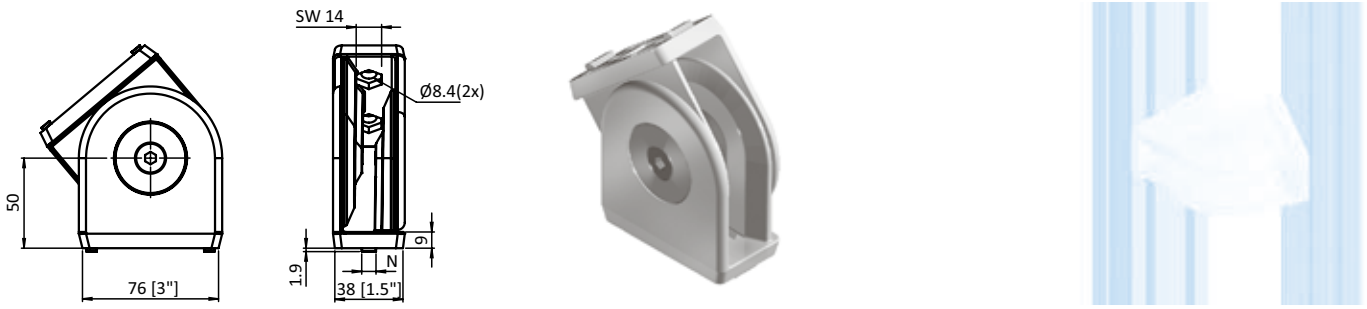

Gelenk 38 x 76 - 1,5" x 3" Pivot Joint 38 x 76 - 1.5" x 3"	N	Öffnungswinkel Opening Angle	Gewicht [g] Weight [g]	Teil-Nr. Part #
	- / 8 / 10	184°	947.0	093G3876AN

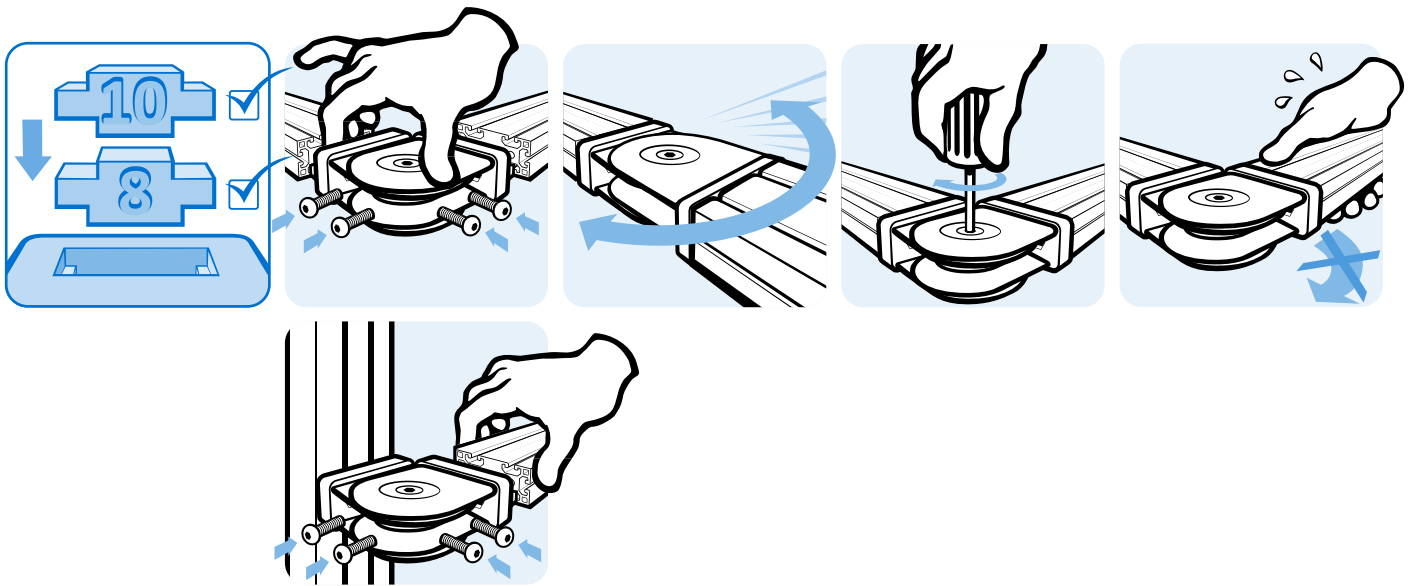



Gelenk 38 x 76 - 1,5" x 3" MIT KLEMMHEBEL

PIVOT JOINT 38 x 76 - 1.5" x 3" WITH LOCKING LEVER

Ausführung	Zinkdruckguss	Model	Zinc die-cast
Beschreibung	zur Verbindung von zwei Profilen oder Flächenelementen, in beliebigen Winkeln fixierbar, mit separaten Nutfixierungen für Nut 8 und Nut 10; mittels der Schrauben und des M_{KMP} -Klemmhebels kann der Reibungswiderstand des Gelenkes stufenlos reguliert, bzw. das Gelenk in einer definierten Position fixiert werden	Description	To make a pivoting connection between two profiles or panels which can be fixed at any angle; with separate locating pins for slot 8 and 10; by tightening or loosening the screws and the M_{KMP} -locking lever you can seamlessly regulate the functionality of the joint or you can fix it in one position
Material	Gelenk: Zinkdruckguss M_{KMP} -Klemmhebel: Zinkdruckguss	Material	Joint: Zinc die-cast M_{KMP} -locking lever: Zinc die-cast
Oberfläche	Gelenk: alufarbig pulverbeschichtet M_{KMP} -Klemmhebel: silbermetallic kunststoffbeschichtet	Surface	Joint: Alu color powder coated M_{KMP} -locking lever: silver metallic plastic coated
Liefereinheit	10 Stück	Pack Quantity	10 pieces
Extras	weitere Oberflächen, weitere Farben auf Anfrage	Specials	Other surfaces, other colors on request

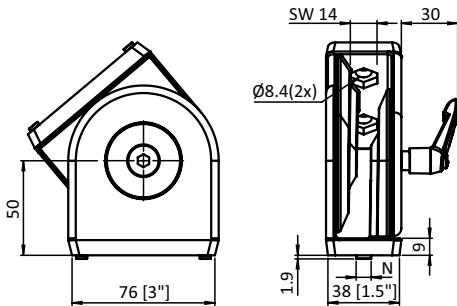

Gelenk 38 x 76 - 1,5" x 3" mit Klemmhebel
Pivot Joint 38 x 76 - 1.5" x 3" with Locking Lever

N	Öffnungswinkel Opening Angle	Gewicht [g] Weight [g]	Teil-Nr. Part #
- / 8 / 10	184°	970.0	093GF3876AN

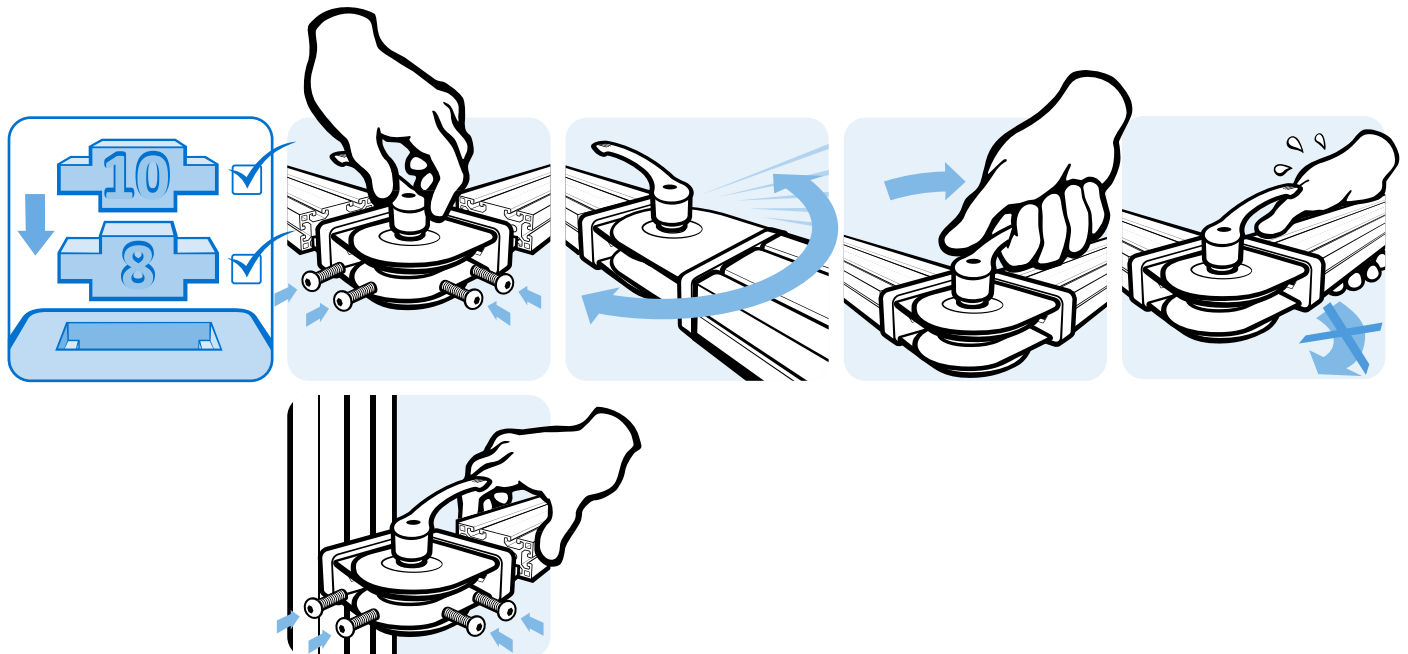



GELENK 40

PIVOT JOINT 40

<p>Ausführung mit einstellbarer Friktion, Zinkdruckguss</p> <p>Beschreibung zur beweglichen Verbindung von zwei Profilen oder Flächenelementen, mit separaten Nutfixierungen für Nut 8 und Nut 10; mittels der Schrauben kann der Reibungswiderstand des Gelenkes stufenlos reguliert, bzw. das Gelenk in einer definierten Position fixiert werden</p> <p>Material Zinkdruckguss</p> <p>Liefereinheit 10 Stück</p> <p>Extras weitere Oberflächen, weitere Farben auf Anfrage</p> <p>Hinweis Schneidhülse zur Reduzierung des Kernlochs Ø10,2 mm auf Gewindegröße M8 siehe Seite 500</p>	<p>Model With adjustable friction, zinc die-cast</p> <p>Description To make a pivoting connection between two profiles or panels; with separate locating pins for slot 8 and 10; by tightening or loosening the screws you can seamlessly regulate the functionality of the joint or you can fix it in one position</p> <p>Material Zinc die-cast</p> <p>Pack Quantity 10 pieces</p> <p>Specials Other surfaces, other colors on request</p> <p>Tip Cut bush for the reduction of the Ø 10.2 mm core hole to thread size M8 see page 500</p>
--	--

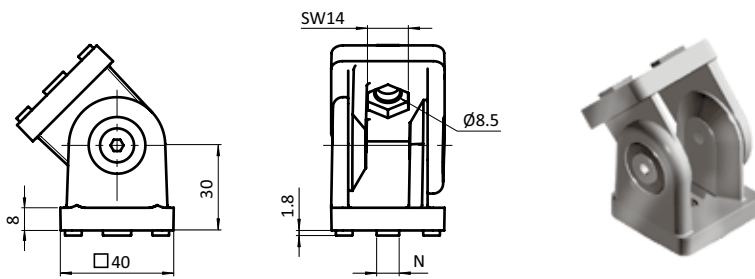

Gelenk 40 Pivot Joint 40	N	Öffnungswinkel Opening Angle	Gewicht [g] Weight [g]	Teil-Nr. Part #
	- / 8 / 10	192°	305.0	093G40AN

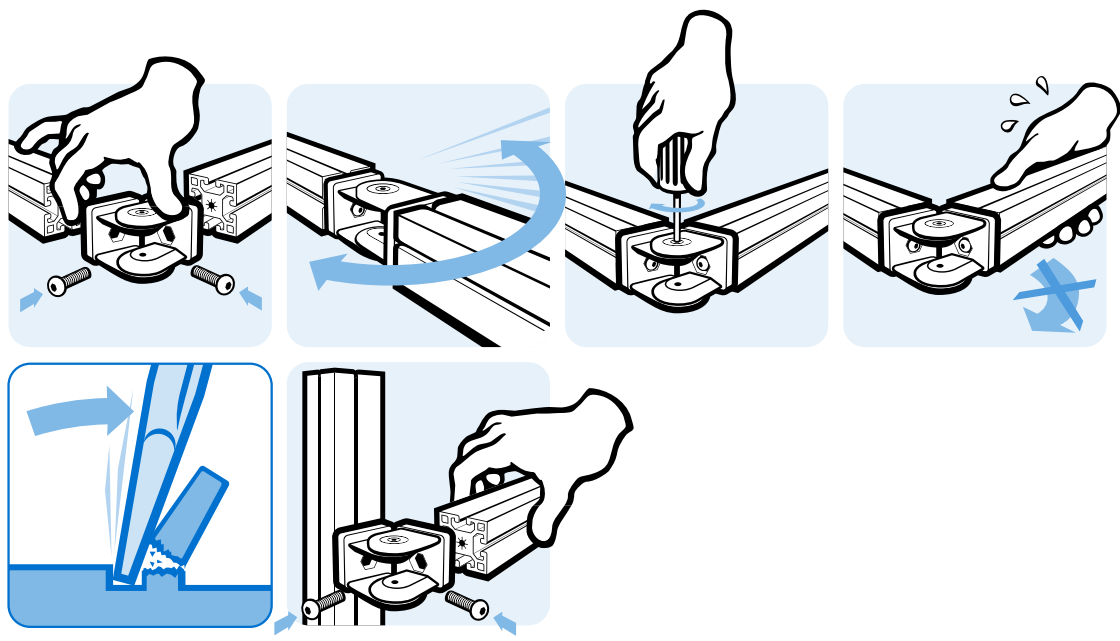



Gelenk 40 MIT KLEMMHEBEL

PIVOT JOINT 40 WITH LOCKING LEVER

<p>Ausführung Zinkdruckguss</p> <p>Beschreibung zur Verbindung von zwei Profilen oder Flächenelementen, in beliebigen Winkeln fixierbar, mit separaten Nutfixierungen für Nut 8 und Nut 10; mittels der Schrauben und des M_{10}-Klemmhebels kann der Reibungswiderstand des Gelenkes stufenlos reguliert, bzw. das Gelenk in einer definierten Position fixiert werden</p> <p>Material Gelenk: Zinkdruckguss M_{10}-Klemmhebel: Kunststoff PA, glasfaserverstärkt</p> <p>Liefereinheit 10 Stück</p> <p>Extras weitere Oberflächen, weitere Farben auf Anfrage</p> <p>Hinweis Schneidhülse zur Reduzierung des Kernlochs $\varnothing 10,2$ mm auf Gewindegröße M8 siehe Seite 500</p>	<p>Model Zinc die-cast</p> <p>Description To make a pivoting connection between two profiles or panels which can be fixed at any angle; with separate locating pins for slot 8 and 10; by tightening or loosening the screws and the M_{10}-locking lever you can seamlessly regulate the functionality of the joint or you can fix it in one position</p> <p>Material Joint: Zinc die-cast M_{10}-locking lever: Plastic PA, glass fiber reinforced</p> <p>Pack Quantity 10 pieces</p> <p>Specials Other surfaces, other colors on request</p> <p>Tip Cut bush for the reduction of the $\varnothing 10.2$ mm core hole to thread size M8 see page 500</p>
---	--

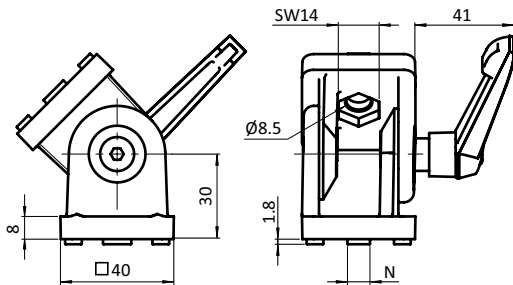

Gelenk 40 mit Klemmhebel
Pivot Joint 40 with Locking Lever

N

Öffnungswinkel
Opening Angle

Gewicht [g]
Weight [g]

Teil-Nr.
Part #

- / 8 / 10

192°

338.0

093GF40AN

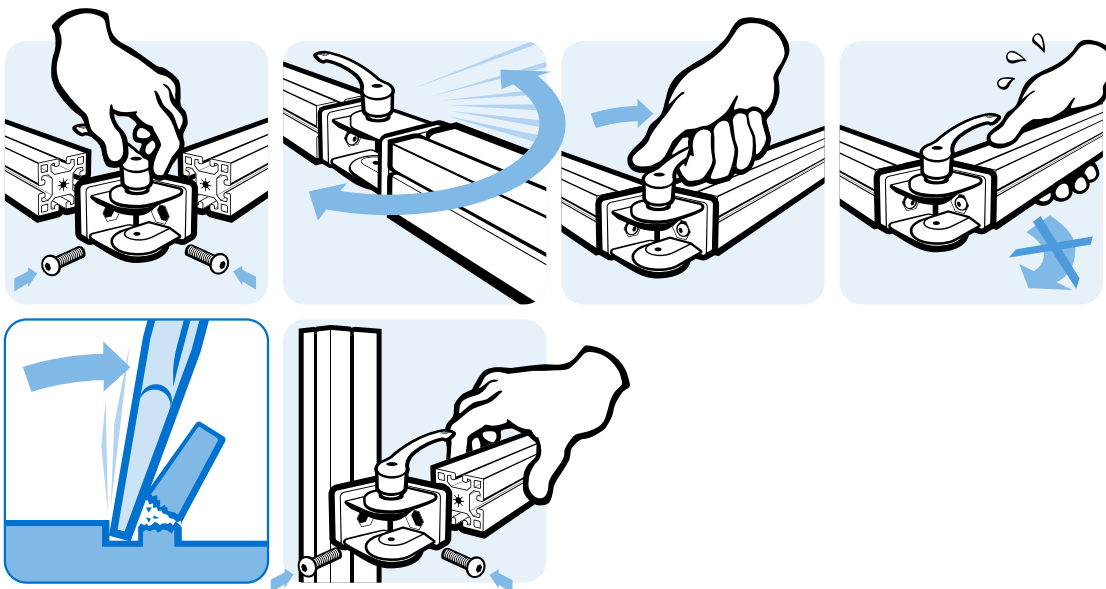



GELENK 40/80

PIVOT JOINT 40/80

<p>Ausführung mit einstellbarer Friktion, Zinkdruckguss</p> <p>Beschreibung zur beweglichen Verbindung von zwei Profilen oder Flächenelementen, mit separaten Nutfixierungen für Nut 8 und Nut 10; mittels der Schrauben kann der Reibungswiderstand des Gelenkes stufenlos reguliert, bzw. das Gelenk in einer definierten Position fixiert werden</p> <p>Material Zinkdruckguss</p> <p>Liefereinheit 10 Stück</p> <p>Extras weitere Oberflächen, weitere Farben auf Anfrage</p> <p>Hinweis Schneidhülse zur Reduzierung des Kernlochs Ø10,2 mm auf Gewindegröße M8 siehe 09308801</p>	<p>Model With adjustable friction, zinc die-cast</p> <p>Description To make a pivoting connection between two profiles or panels; with separate locating pins for slot 8 and 10; by tightening or loosening the screws you can seamlessly regulate the functionality of the joint or you can fix it in one position</p> <p>Material Zinc die-cast</p> <p>Pack Quantity 10 pieces</p> <p>Specials Other surfaces, other colors on request</p> <p>Tip Cut bush for the reduction of the Ø 10.2 mm core hole to thread size M8 see 09308801</p>
---	--

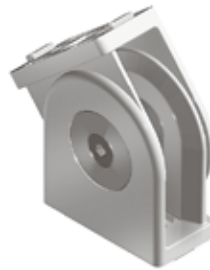
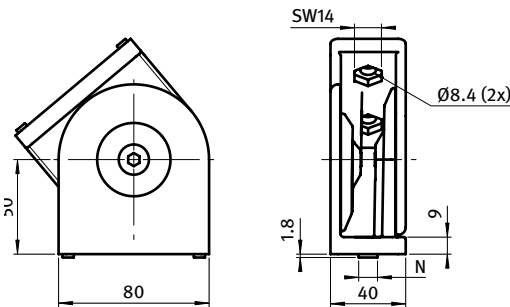

Gelenk 40 x 80 Pivot Joint 40 x 80	N	Öffnungswinkel Opening Angle	Gewicht [g] Weight [g]	Teil-Nr. Part #
	- / 8 / 10	184°	997.0	093G4080AN

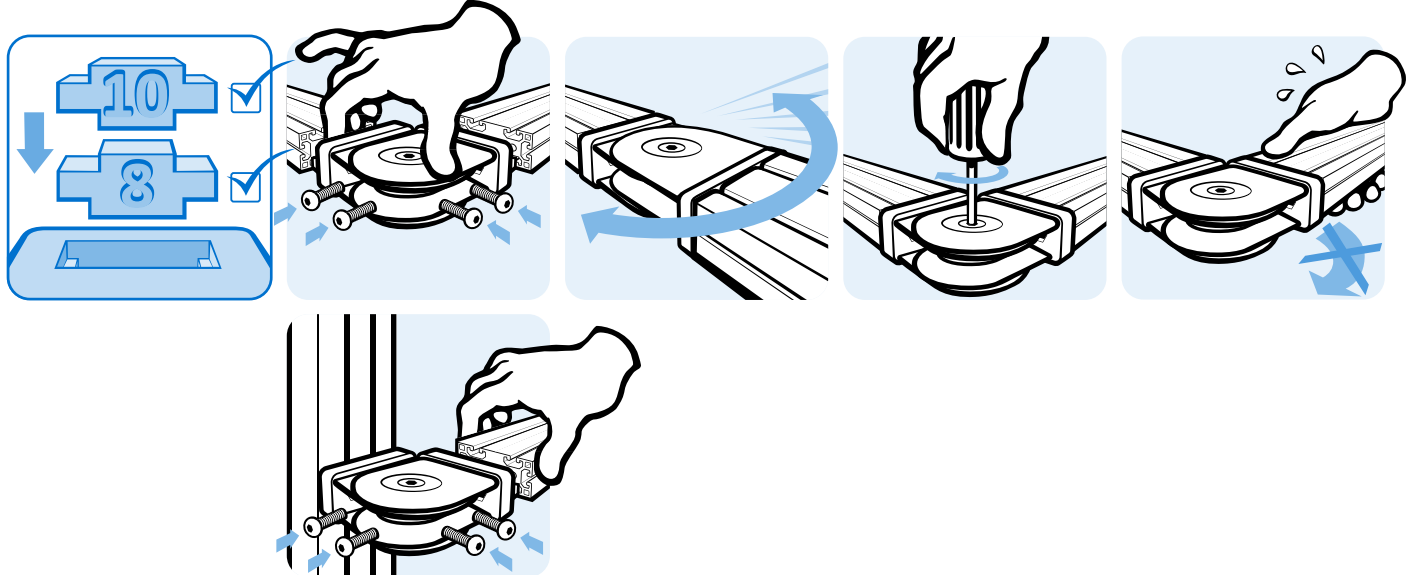



GELENK 40 × 80 MIT KLEMMHEBEL

PIVOT JOINT 40 × 80 WITH LOCKING LEVER

<p>Ausführung Zinkdruckguss</p> <p>Beschreibung zur Verbindung von zwei Profilen oder Flächenelementen, in beliebigen Winkeln fixierbar, mit separaten Nutfixierungen für Nut 8 und Nut 10; mittels der Schrauben und des M_{Klemm}-Klemmhebels kann der Reibungswiderstand des Gelenkes stufenlos reguliert, bzw. das Gelenk in einer definierten Position fixiert werden</p> <p>Material Gelenk: Zinkdruckguss M_{Klemm}-Klemmhebel: Zinkdruckguss</p> <p>Liefereinheit 10 Stück</p> <p>Extras weitere Oberflächen, weitere Farben auf Anfrage</p> <p>Hinweis Schneidhülse zur Reduzierung des Kernlochs $\varnothing 10,2$ mm auf Gewindegröße M8 siehe Seite 500</p>	<p>Model Zinc die-cast</p> <p>Description To make a pivoting connection between two profiles or panels which can be fixed at any angle; with separate locating pins for slot 8 and 10; by tightening or loosening the screws and the M_{Klemm}-locking lever you can seamlessly regulate the functionality of the joint or you can fix it in one position</p> <p>Material Joint: Zinc die-cast M_{Klemm}-locking lever: Zinc die-cast</p> <p>Pack Quantity 10 pieces</p> <p>Specials Other surfaces, other colors on request</p> <p>Tip Cut bush for the reduction of the $\varnothing 10.2$ mm core hole to thread size M8 see page 500</p>
---	---

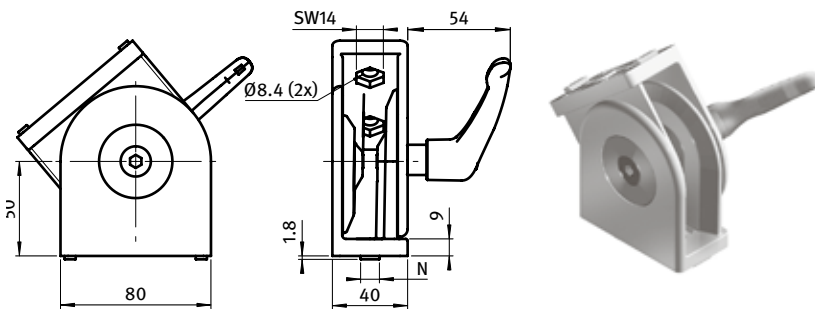

Gelenk 40 × 80 mit Klemmhebel <i>Pivot Joint 40 × 80 with Locking Lever</i>	N	Öffnungswinkel <i>Opening Angle</i>	Gewicht [g] <i>Weight [g]</i>	Teil-Nr. <i>Part #</i>
	- / 8 / 10	184°	1120.0	093GF4080AN

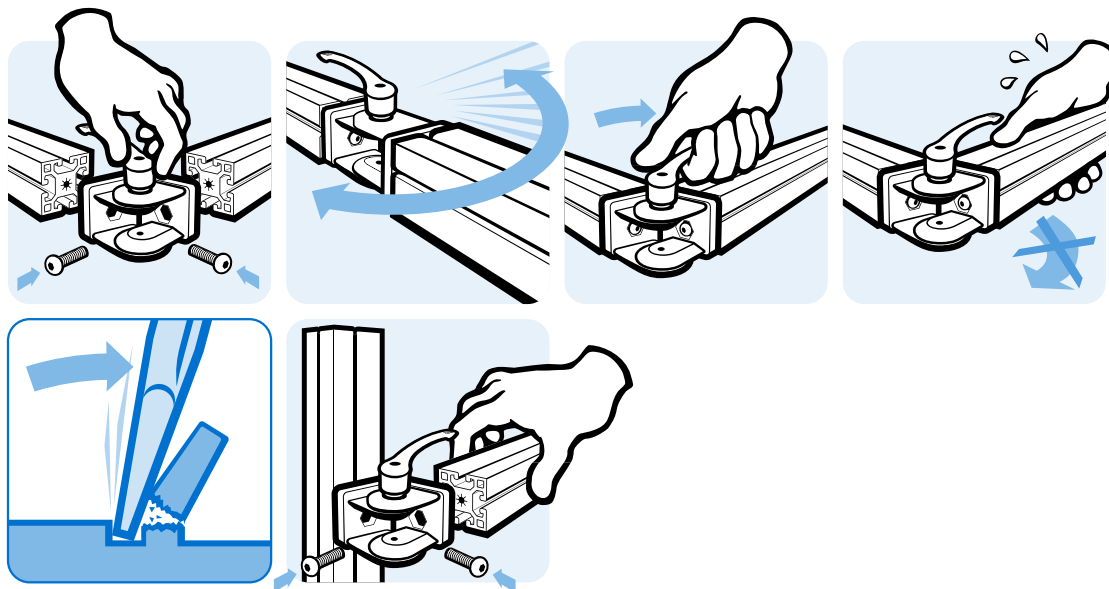



GELENK 45

PIVOT JOINT 45

Ausführung mit einstellbarer Friktion, Aluminiumdruckguss

Model With adjustable friction, die-cast aluminum

Beschreibung zur beweglichen Verbindung von zwei Profilen oder Flächenelementen, mit separaten Nutfixierungen für Nut 8 und Nut 10; mittels der Schrauben kann der Reibungswiderstand des Gelenkes stufenlos reguliert, bzw. das Gelenk in einer definierten Position fixiert werden

Description To make a pivoting connection between two profiles or panels; with separate locating pins for slot 8 and 10; by tightening or loosening the screws you can seamlessly regulate the functionality of the joint or you can fix it in one position

Material Aluminiumdruckguss

Material Aluminum die-cast

Liefereinheit 10 Stück

Pack Quantity 10 pieces

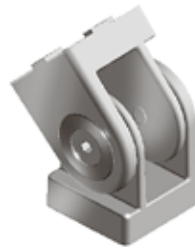
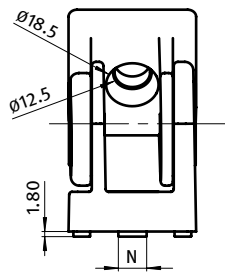
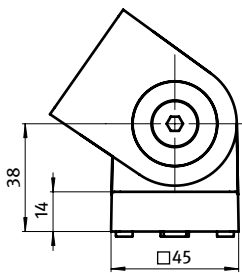

Gelenk 45
Pivot Joint 45

N

Öffnungswinkel
Opening Angle

Gewicht [g]
Weight [g]

Teil-Nr.
Part #

- / 8 / 10

190°

264.0

093GA45AN

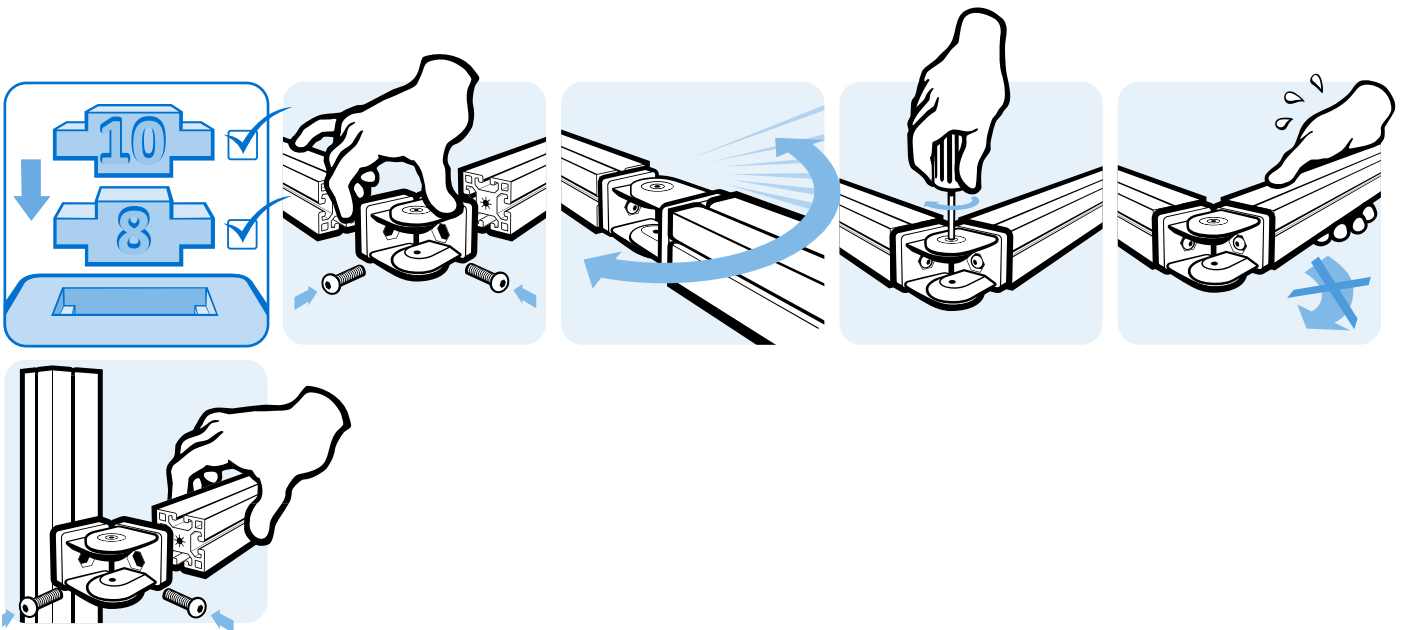



GELENK 45 MIT KLEMMHEBEL

PIVOT JOINT 45 WITH LOCKING LEVER

<p>Ausführung Aluminiumdruckguss</p> <p>Beschreibung zur Verbindung von zwei Profilen oder Flächenelementen, in beliebigen Winkeln fixierbar, mit separaten Nutfixierungen für Nut 8 und Nut 10; mittels der Schrauben und des M_{KMP}-Klemmhebels kann der Reibungswiderstand des Gelenkes stufenlos reguliert, bzw. das Gelenk in einer definierten Position fixiert werden</p> <p>Material Gelenk: Aluminiumdruckguss M_{KMP}-Klemmhebel: Kunststoff PA, glasfaserverstärkt</p> <p>Liefereinheit 10 Stück</p>	<p>Model Aluminum die-cast</p> <p>Description To make a pivoting connection between two profiles or panels which can be fixed at any angle; with separate locating pins for slot 8 and 10; by tightening or loosening the screws and the M_{KMP}-locking lever you can seamlessly regulate the functionality of the joint or you can fix it in one position</p> <p>Material Joint: Aluminum die-cast M_{KMP}-locking lever: Plastic PA, glass fiber reinforced</p> <p>Pack Quantity 10 pieces</p>
--	---

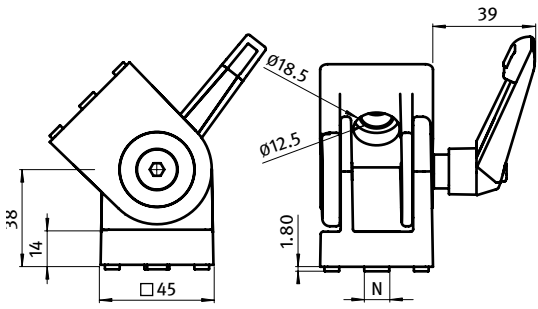

Gelenk 45 mit Klemmhebel <i>Pivot Joint 45 with Locking Lever</i>	N	Öffnungswinkel <i>Opening Angle</i>	Gewicht [g] <i>Weight [g]</i>	Teil-Nr. <i>Part #</i>
	- / 8 / 10	190°	289.0	093GAF45AN

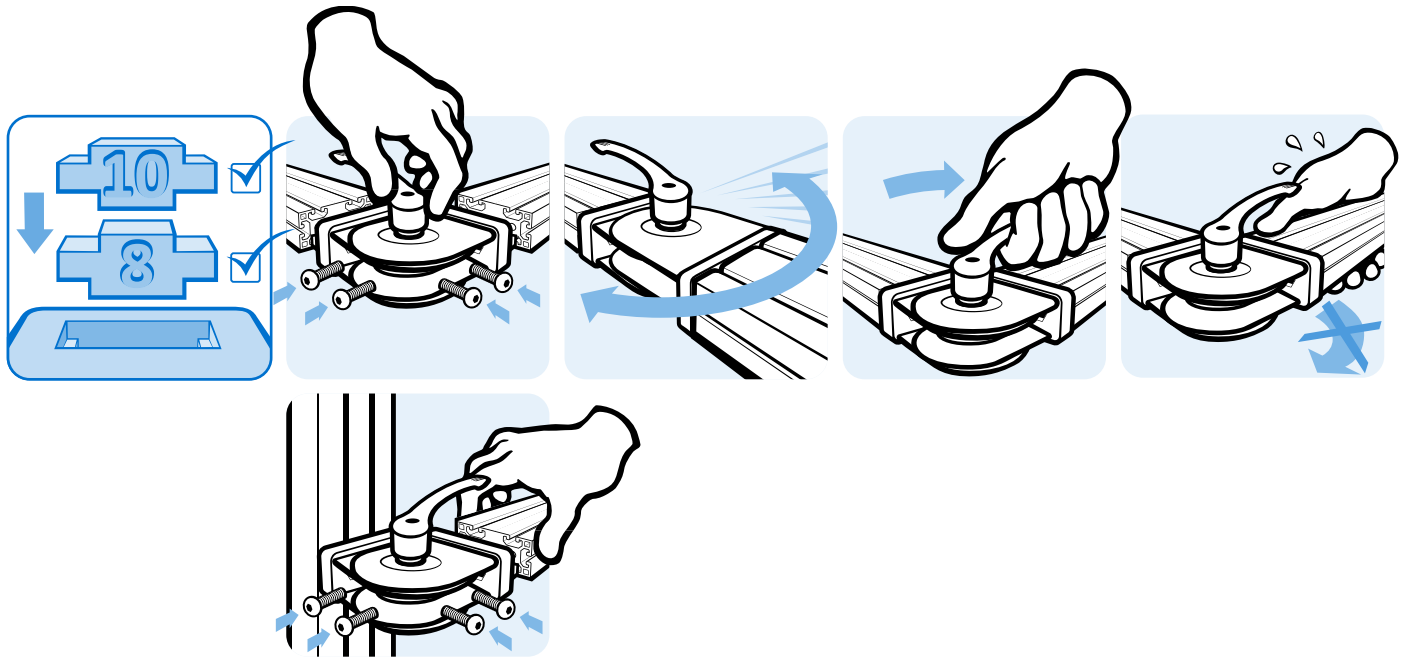



GELENK 45

PIVOT JOINT 45

<p>Ausführung mit einstellbarer Friktion, Zinkdruckguss</p> <p>Beschreibung zur beweglichen Verbindung von zwei Profilen oder Flächenelementen, mit separaten Nutfixierungen für Nut 8 und Nut 10; mittels der Schrauben kann der Reibungswiderstand des Gelenkes stufenlos reguliert, bzw. das Gelenk in einer definierten Position fixiert werden</p> <p>Material Zinkdruckguss</p> <p>Liefereinheit 10 Stück</p> <p>Extras weitere Oberflächen, weitere Farben auf Anfrage</p> <p>Hinweis Schneidhülse zur Reduzierung des Kernlochs Ø10,2 mm auf Gewindegröße M8 siehe Seite 500</p>	<p>Model With adjustable friction, zinc die-cast</p> <p>Description To make a pivoting connection between two profiles or panels; with separate locating pins for slot 8 and 10; by tightening or loosening the screws you can seamlessly regulate the functionality of the joint or you can fix it in one position</p> <p>Material Zinc die-cast</p> <p>Pack Quantity 10 pieces</p> <p>Specials Other surfaces, other colors on request</p> <p>Tip Cut bush for the reduction of the Ø 10.2 mm core hole to thread size M8 see page 500</p>
--	--

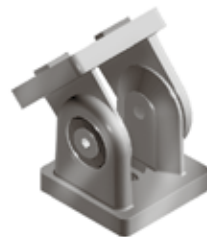
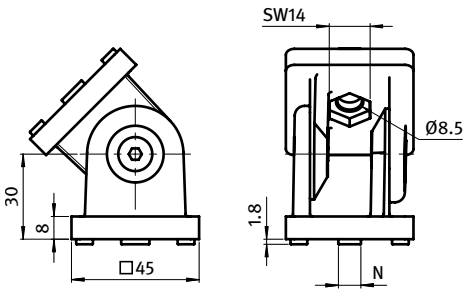

Gelenk 45 Pivot Joint 45	N	Öffnungswinkel Opening Angle	Gewicht [g] Weight [g]	Teil-Nr. Part #
	- / 8 / 10	178°	339.0	093G45AN

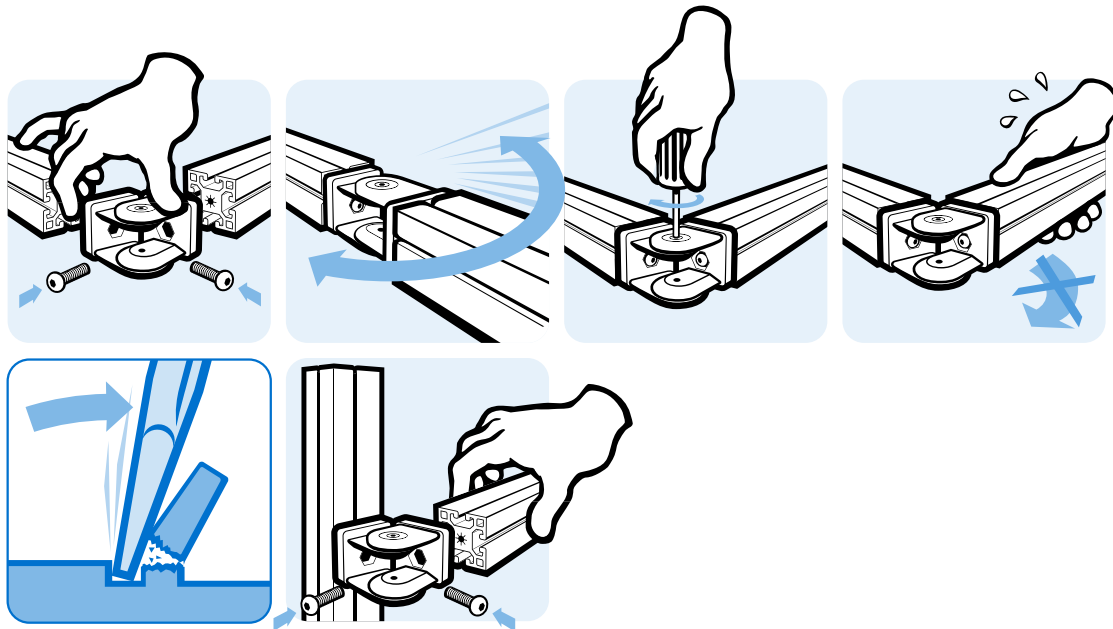



GELENK 45 MIT KLEMMHEBEL

PIVOT JOINT 45 WITH LOCKING LEVER

<p>Ausführung Zinkdruckguss</p> <p>Beschreibung zur Verbindung von zwei Profilen oder Flächenelementen, in beliebigen Winkeln fixierbar, mit separaten Nutfixierungen für Nut 8 und Nut 10; mittels der Schrauben und des M_{10}-Klemmhebels kann der Reibungswiderstand des Gelenkes stufenlos reguliert, bzw. das Gelenk in einer definierten Position fixiert werden</p> <p>Material Gelenk: Zinkdruckguss M_{10}-Klemmhebel: Kunststoff PA, glasfaserverstärkt</p> <p>Liefereinheit 10 Stück</p> <p>Extras weitere Oberflächen, weitere Farben auf Anfrage</p> <p>Hinweis Schneidhülse zur Reduzierung des Kernlochs $\varnothing 10,2$ mm auf Gewindegröße M8 siehe Seite 500</p>	<p>Model Zinc die-cast</p> <p>Description To make a pivoting connection between two profiles or panels which can be fixed at any angle; with separate locating pins for slot 8 and 10; by tightening or loosening the screws and the M_{10}-locking lever you can seamlessly regulate the functionality of the joint or you can fix it in one position</p> <p>Material Joint: Zinc die-cast M_{10}-locking lever: Plastic PA, glass fiber reinforced</p> <p>Pack Quantity 10 pieces</p> <p>Specials Other surfaces, other colors on request</p> <p>Tip Cut bush for the reduction of the $\varnothing 10.2$ mm core hole to thread size M8 see page 500</p>
---	--

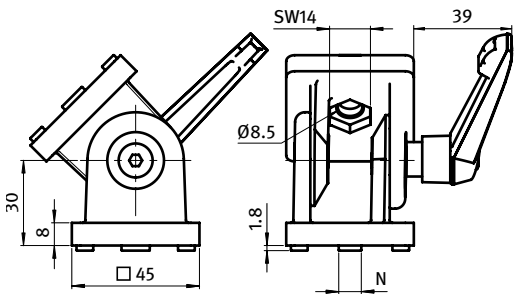

Gelenk 45 mit Klemmhebel <i>Pivot Joint 45 with Locking Lever</i>	N	Öffnungswinkel <i>Opening Angle</i>	Gewicht [g] <i>Weight [g]</i>	Teil-Nr. <i>Part #</i>
	- / 8 / 10	178°	387.0	093GF45AN

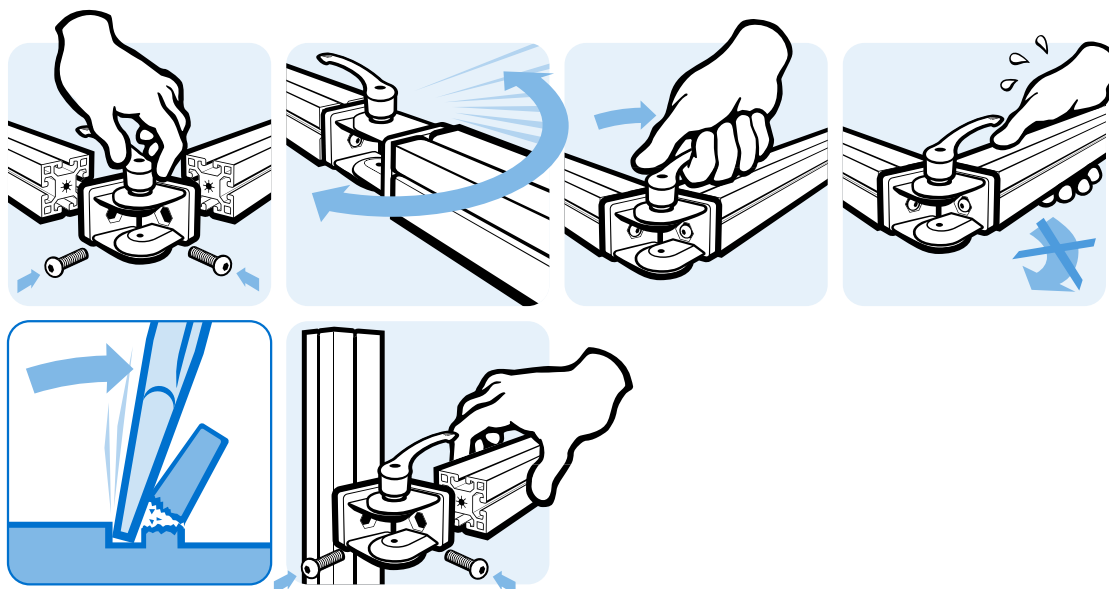



GELENK 45 x 90

PIVOT JOINT 45 x 90

<p>Ausführung mit einstellbarer Friktion, Zinkdruckguss</p> <p>Beschreibung zur beweglichen Verbindung von zwei Profilen oder Flächenelementen, mit separaten Nutfixierungen für Nut 8 und Nut 10; mittels der Schrauben kann der Reibungswiderstand des Gelenkes stufenlos reguliert, bzw. das Gelenk in einer definierten Position fixiert werden</p> <p>Material Zinkdruckguss</p> <p>Liefereinheit 10 Stück</p> <p>Extras weitere Oberflächen, weitere Farben auf Anfrage</p> <p>Hinweis Schneidhülse zur Reduzierung des Kernlochs Ø10,2 mm auf Gewindegröße M8 siehe Seite 500</p>	<p>Model With adjustable friction, zinc die-cast</p> <p>Description To make a pivoting connection between two profiles or panels; with separate locating pins for slot 8 and 10; by tightening or loosening the screws you can seamlessly regulate the functionality of the joint or you can fix it in one position</p> <p>Material Zinc die-cast</p> <p>Pack Quantity 10 pieces</p> <p>Specials Other surfaces, other colors on request</p> <p>Tip Cut bush for the reduction of the Ø 10.2 mm core hole to thread size M8 see page 500</p>
--	--

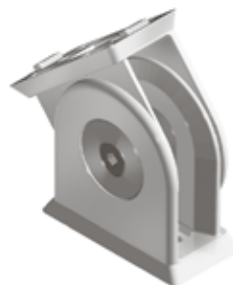
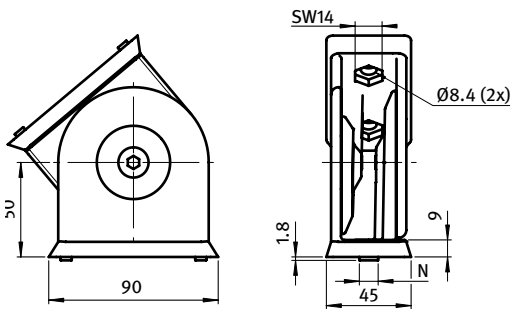

Gelenk 45 x 90 Pivot Joint 45 x 90	N	Öffnungswinkel Opening Angle	Gewicht [g] Weight [g]	Teil-Nr. Part #
	- / 8 / 10	184°	1046.0	093G4590AN

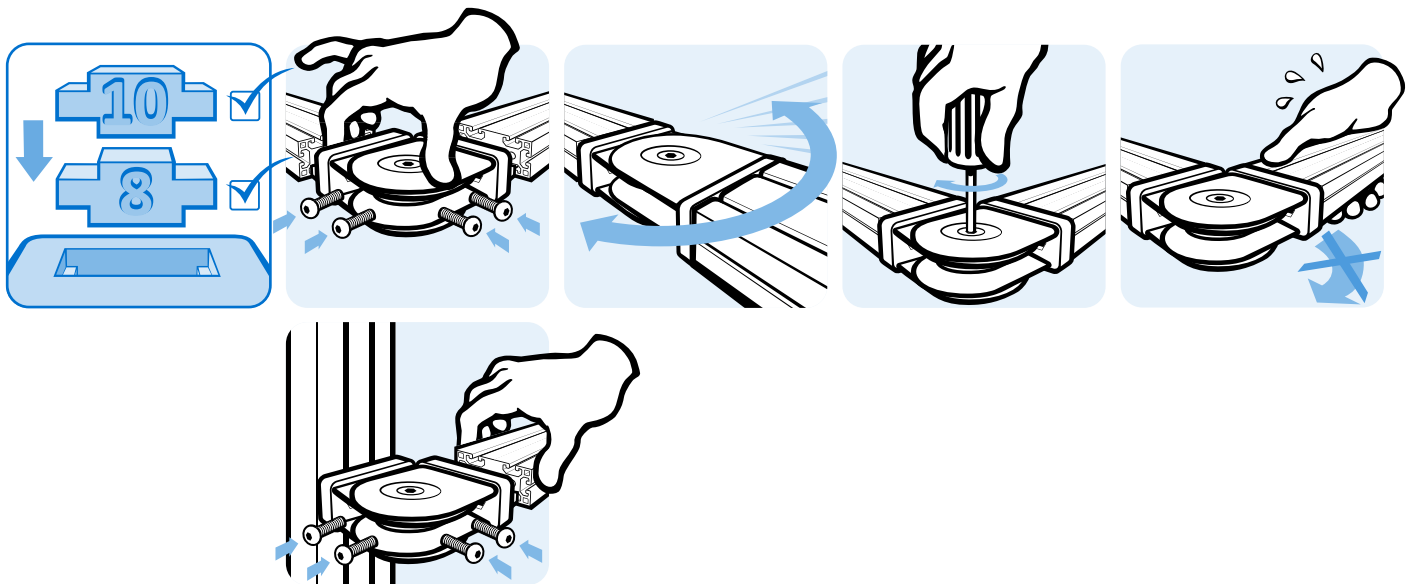



GELENK 45 × 90 MIT KLEMMHEBEL

PIVOT JOINT 45 × 90 WITH LOCKING LEVER

Ausführung	Zinkdruckguss	Model	Zinc die-cast
Beschreibung	zur Verbindung von zwei Profilen oder Flächenelementen, in beliebigen Winkeln fixierbar, mit separaten Nutfixierungen für Nut 8 und Nut 10; mittels der Schrauben und des M_{Klemm} -Klemmhebels kann der Reibungswiderstand des Gelenkes stufenlos reguliert, bzw. das Gelenk in einer definierten Position fixiert werden	Description	To make a pivoting connection between two profiles or panels which can be fixed at any angle; with separate locating pins for slot 8 and 10; by tightening or loosening the screws and the M_{Klemm} -locking lever you can seamlessly regulate the functionality of the joint or you can fix it in one position
Material	Gelenk: Zinkdruckguss M_{Klemm} -Klemmhebel: Zinkdruckguss	Material	Joint: Zinc die-cast M_{Klemm} -locking lever: Zinc die-cast
Liefereinheit	10 Stück	Pack Quantity	10 pieces
Extras	weitere Oberflächen, weitere Farben auf Anfrage	Specials	Other surfaces, other colors on request
Hinweis	Schneidhülse zur Reduzierung des Kernlochs $\varnothing 10,2$ mm auf Gewindegröße M8 siehe Seite 500	Tip	Cut bush for the reduction of the $\varnothing 10.2$ mm core hole to thread size M8 see page 500

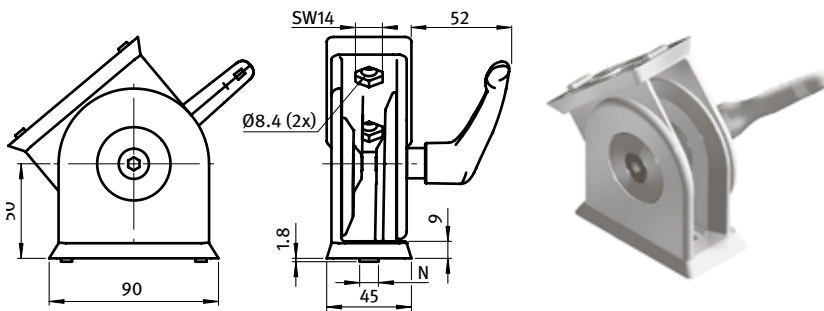

Gelenk 45 × 90 mit Klemmhebel <i>Pivot Joint 45 × 90 with Locking Lever</i>	N	Öffnungswinkel <i>Opening Angle</i>	Gewicht [g] <i>Weight [g]</i>	Teil-Nr. <i>Part #</i>
	- / 8 / 10	184°	1069.0	093GF4590AN

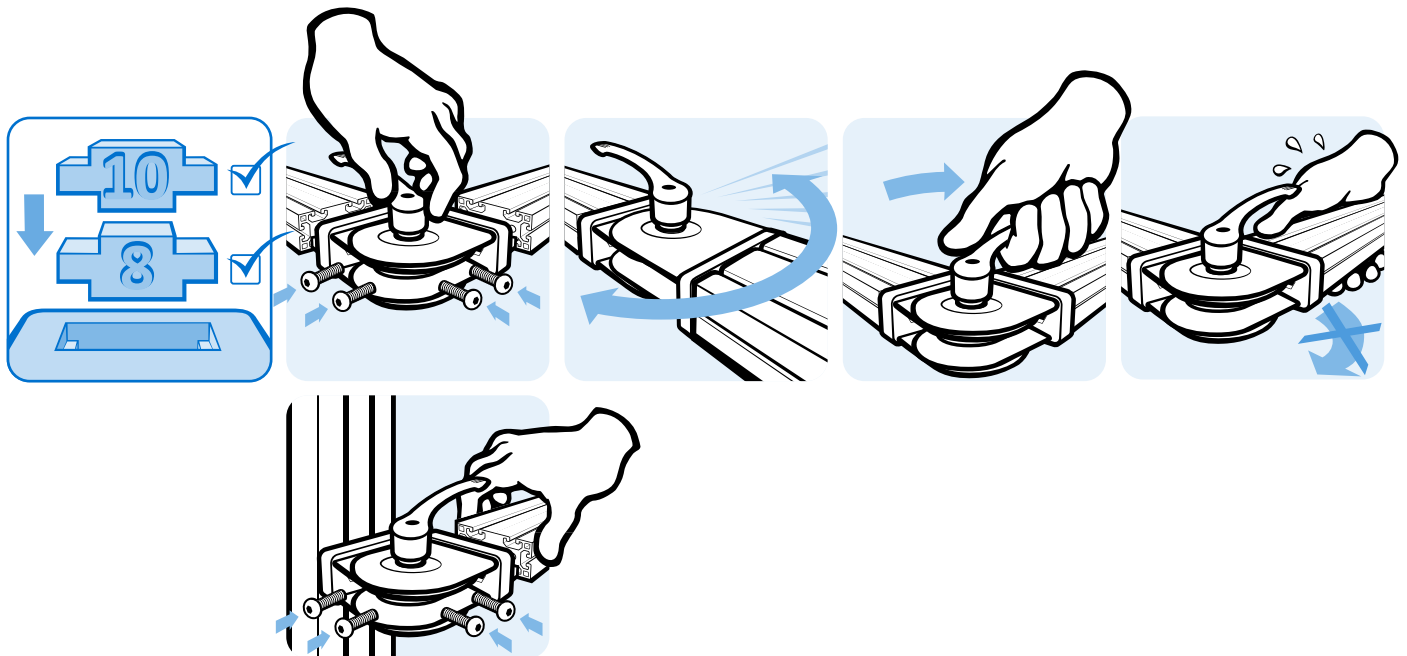



GELENK 180°, 1 NUT

PIVOT JOINT 180°, 1 SLOT VERSION

Ausführung	Aludruckguss	Model	Aluminum die-cast
Beschreibung	zur beweglichen Verbindung von zwei Profilen, mit separaten Nutfixierungen	Description	To make a pivoting connection between two profiles, with separate locating pins
Material	Gelenk: Aludruckguss Nutfixierung 5/6: Kunststoff Nutfixierung 8/10: Zinkdruckguss	Material	Joint: Aluminum die-cast Centering piece 5/6: Plastic PA Centering piece 8/10: Zinc die-cast
Liefereinheit	10 Stück	Pack Quantity	10 pieces
Extras	weitere Oberflächen, weitere Farben auf Anfrage	Specials	Other surfaces, other colors on request

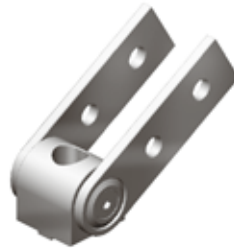
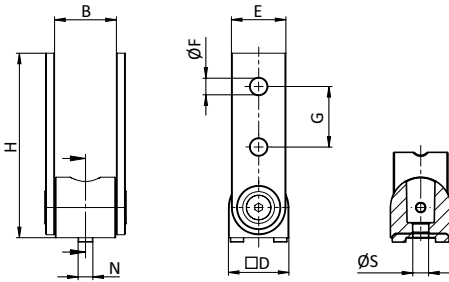

Gelenk 180°, 1 Nut Pivot Joint 180°, 1 Slot Version	B [mm]	D [mm]	E [mm]	G [mm]	H [mm]	N	ØF [mm]	ØS [mm]	für Profil For Profile	Gewicht [g] Weight [g]	Teil-Nr. Part #
	20.4	20.0	18.0	20.0	61.0	5 / 6	5.5	5.2	20	32.0	093GV20
	30.4	30.0	28.0	30.0	86.0	6 / 8	6.5	6.4	30	92.2	093GV30
	40.6	40.0	37.0	40.0	121.5	8 / 10	8.5	8.5	40	255.0	093GV40
	45.6	45.0	42.0	45.0	141.5	8 / 10	8.5	8.5	45	363.0	093GV45

4



GELENK 180°, 2 NUTEN

PIVOT JOINT 180°, 2 SLOT VERSION

Ausführung	Aludruckguss	Model	Aluminum die-cast
Beschreibung	zur beweglichen Verbindung von zwei Profilen, mit separaten Nutfixierungen	Description	To make a pivoting connection between two profiles, with separate locating pins
Material	Gelenk: Aludruckguss Nutfixierung 5/6: Kunststoff Nutfixierung 8/10: Zinkdruckguss	Material	Joint: Aluminum die-cast Centering piece 5/6: Plastic PA Centering piece 8/10: Zinc die-cast
Liefereinheit	10 Stück	Pack Quantity	10 pieces
Extras	weitere Oberflächen, weitere Farben auf Anfrage	Specials	Other surfaces, other colors on request

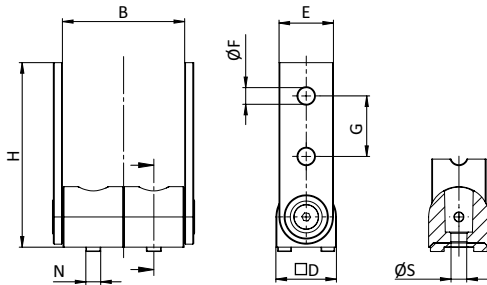

Gelenk 180°, 2 Nuten Pivot Joint 180°, 2 Slot Version	B [mm]	D [mm]	E [mm]	G [mm]	H [mm]	N	ØF [mm]	ØS [mm]	für Profil For Profile	Gewicht [g] Weight [g]	Teil-Nr. Part #
	40.4	20.0	18.0	20.0	61.0	5 / 6	5.5	5.2	20	45.0	093GV2040
	60.4	30.0	28.0	30.0	86.0	6 / 8	6.5	6.4	30	129.0	093GV3060
	80.6	40.0	37.0	40.0	121.5	8 / 10	8.5	8.5	40	358.0	093GV4080
	90.6	45.0	42.0	45.0	141.5	8 / 10	8.5	8.5	45	524.0	093GV4590



SCHNEIDHÜLSE

CUTTING BUSH

Ausführung	Stahl verzinkt	Model	Zinc-plated steel
Beschreibung	zur Reduzierung des Kernlochs 10,2 mm auf Gewindegröße M8	Description	For reduction from core hole 10.2 mm to M8 thread
Material	Stahl	Material	Steel
Liefereinheit	100 Stück	Pack Quantity	100 pieces

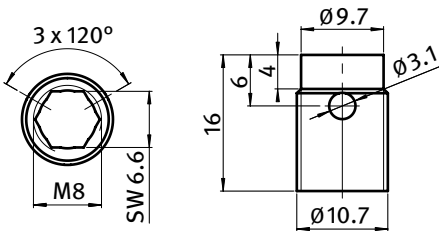

Schneidhülse
Cutting Bush

Gewicht [g]
Weight [g]

Teil-Nr.
Part #

		3.8	09308801
Eindrehwerkzeug <i>Tool</i>		31.5	09308802

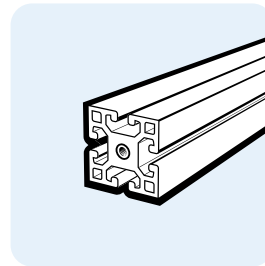
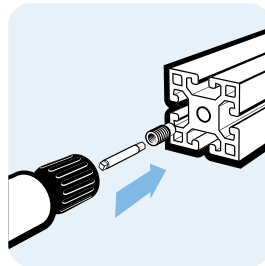



KLEMMWINKEL 30

ADJUSTABLE ANGLE CLAMP 30

Ausführung	Zinkdruckguss	Model	Zinc die-cast
Beschreibung	zur schnellen und flexiblen Verbindung von zwei Aluminium-Profilen	Description	To connect aluminum profiles easily and with flexibility
Material	Zinkdruckguss	Material	Zinc die-cast
Befestigung	mit Schraube M6	Fastening	Using M6 screw
Liefereinheit	10 Stück	Pack Quantity	10 pieces
Extras	weitere Oberflächen, weitere Farben auf Anfrage	Specials	Other surfaces, other colors on request
Hinweis	Weitere Nuten auf Anfrage	Tip	Other slots on request

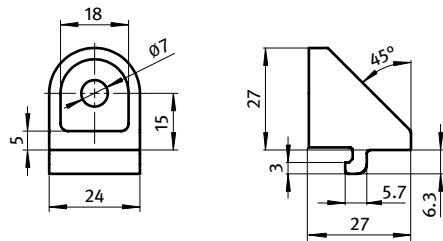

Klemmwinkel <i>Adjustable Angles</i>	Nut <i>Slot</i>	Gewicht [g] <i>Weight [g]</i>	Profil <i>Profile</i>	Teil-Nr. <i>Part #</i>
blank <i>Plain</i>	6	44.0	I	093WK301N06R
alufarbig <i>Alu color</i>	6	44.0	I	093WK301N06A

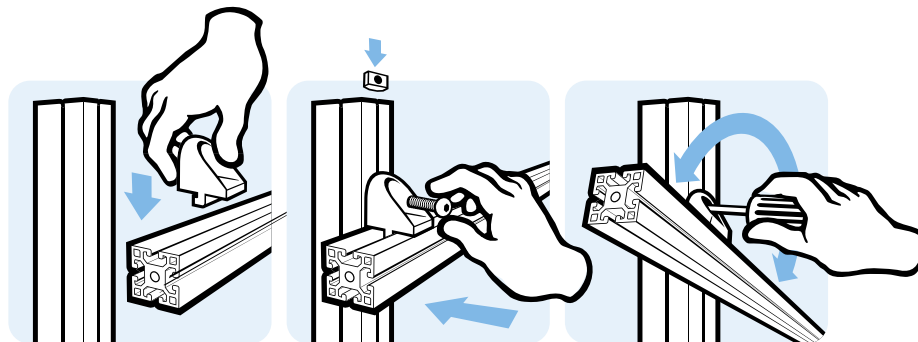



KLEMMWINKEL 30 MIT KLEMMHEBEL

ANGLE CLAMP 30 WITH LOCKING LEVER

Ausführung	Zinkdruckguss	Model	Zinc die-cast
Beschreibung	zur schnellen und flexiblen Verbindung von zwei Aluminium-Profilen	Description	To connect aluminum profiles easily and with flexibility
Material	Winkel: Zinkdruckguss Klemmhebel: Kunststoff PA, glasfaserverstärkt Mechanik: Stahl, blau verzinkt (RoHS-konform)	Material	Bracket: Zinc die-cast Locking lever: Plastic PA, glass fiber reinforced Mechanic: Blue-galvanised steel (RoHS conform)
Befestigung	mit Schraube M6	Fastening	Using M6 screw
Liefereinheit	10 Stück	Pack Quantity	10 pieces
Extras	weitere Oberflächen, weitere Farben auf Anfrage	Specials	Other surfaces, other colors on request
Hinweis	Weitere Nuten auf Anfrage	Tip	Other slots on request

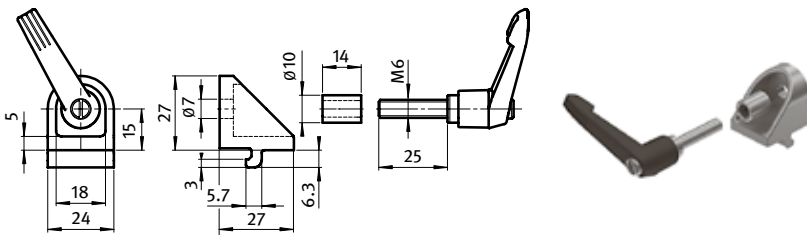

Klemmwinkel <i>Adjustable Angles</i>	Nut <i>Slot</i>	Gewicht [g] <i>Weight [g]</i>	Profil <i>Profile</i>	Teil-Nr. <i>Part #</i>
blank <i>Plain</i>	6	64.0	I	093WKF301N06R
alufarbig <i>Alu color</i>	6	64.0	I	093WKF301N06A

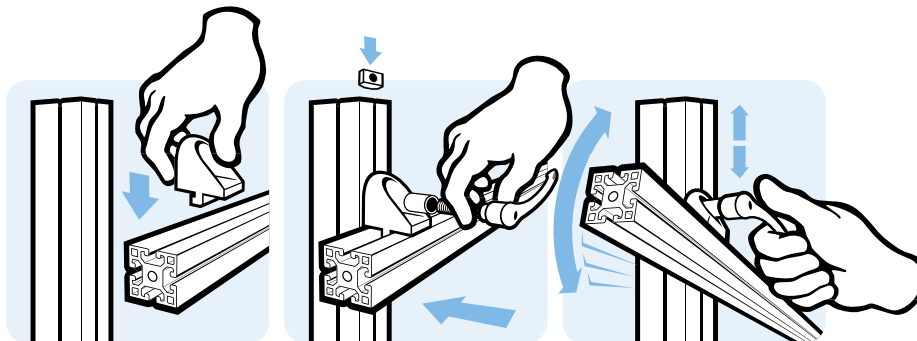



KLEMMWINKEL 40

ADJUSTABLE ANGLE CLAMP 40

Ausführung	Zinkdruckguss	Model	Zinc die-cast
Beschreibung	zur schnellen und flexiblen Verbindung von zwei Aluminium-Profilen	Description	To connect aluminum profiles easily and with flexibility
Material	Zinkdruckguss	Material	Zinc die-cast
Befestigung	mit Schraube M8	Fastening	Using M8 screw
Liefereinheit	10 Stück	Pack Quantity	10 pieces
Extras	weitere Oberflächen, weitere Farben auf Anfrage	Specials	Other surfaces, other colors on request
Hinweis	Weitere Nuten auf Anfrage	Tip	Other slots on request

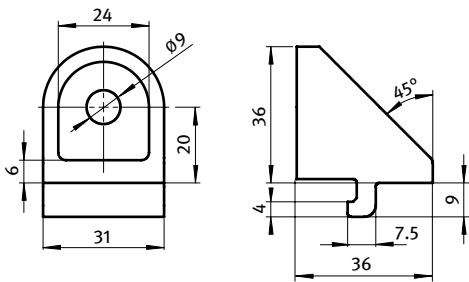

Klemmwinkel <i>Adjustable Angles</i>	Nut <i>Slot</i>	Gewicht [g] <i>Weight [g]</i>	Profil <i>Profile</i>	Teil-Nr. <i>Part #</i>
blank <i>Plain</i>	8	44.0	I	093WK401N08R
alufarbig <i>Alu color</i>	8	44.0	I	093WK401N08A

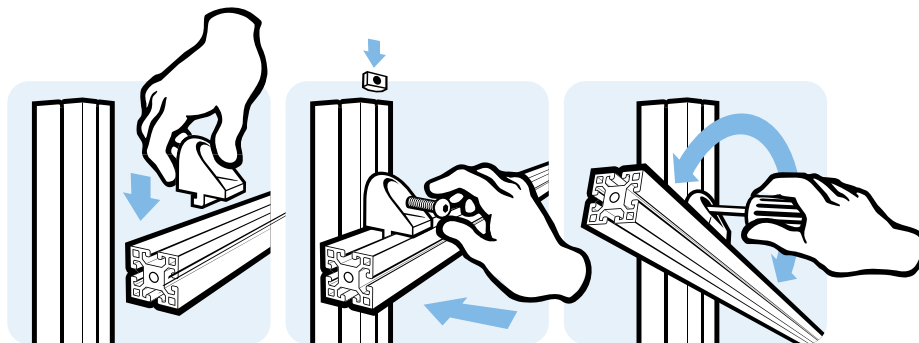



KLEMMWINKEL 40 MIT KLEMMHEBEL

ANGLE CLAMP 40 WITH LOCKING LEVER

Ausführung	Zinkdruckguss	Model	Zinc die-cast
Beschreibung	zur schnellen und flexiblen Verbindung von zwei Aluminium-Profilen	Description	To connect aluminum profiles easily and with flexibility
Material	Winkel: Zinkdruckguss Klemmhebel: Kunststoff PA, glasfaserverstärkt Mechanik: Stahl, blau verzinkt (RoHS-konform)	Material	Bracket: Zinc die-cast Locking lever: Plastic PA, glass fiber reinforced Mechanic: Blue-galvanised steel (RoHS compliant)
Befestigung	mit Schraube M8	Fastening	Using M8 screw
Liefereinheit	10 Stück	Pack Quantity	10 pieces
Extras	weitere Oberflächen, weitere Farben auf Anfrage	Specials	Other surfaces, other colors on request
Hinweis	Weitere Nuten auf Anfrage	Tip	Other slots on request

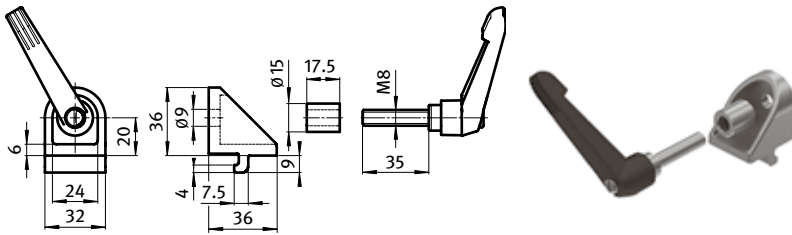

Klemmwinkel <i>Adjustable Angles</i>	Nut <i>Slot</i>	Gewicht [g] <i>Weight [g]</i>	Profil <i>Profile</i>	Teil-Nr. <i>Part #</i>
blank <i>Plain</i>	8	154.0	I	093WKF401N08R
alufarbig <i>Alu color</i>	8	154.0	I	093WKF401N08A

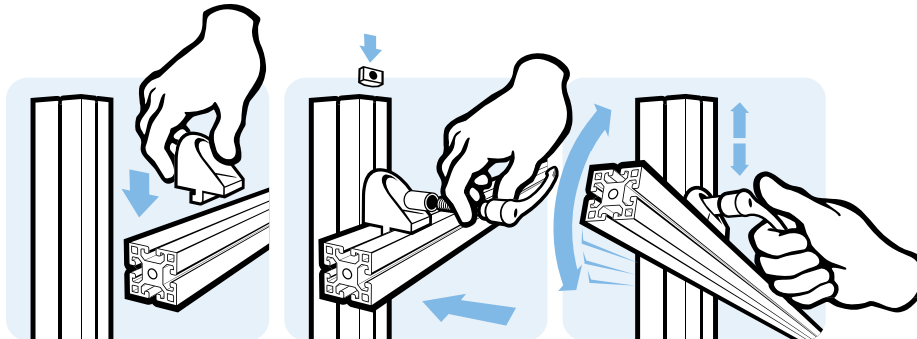



GELENKWINKEL 30

ADJUSTABLE ANGLE 30

Ausführung	Zinkdruckguss	Model	Zinc die-cast
Beschreibung	zur Verbindung von zwei Aluminium-Profilen in verschiedenen Winkeln, durch die Lagerbuchse auch im montierten Zustand frei drehbar	Description	To connect aluminum profiles at various angles; can be turned freely when mounted
Material	Winkel: Zinkdruckguss Buchse: Stahl, verzinkt	Material	Angle: Zinc die-cast Bushing: Steel, zinc plated
Befestigung	mit Schrauben M6	Fastening	Using M6 screws
Liefereinheit	10 Stück	Pack Quantity	10 pieces
Extras	weitere Oberflächen, weitere Farben auf Anfrage	Specials	Other surfaces, other colors on request

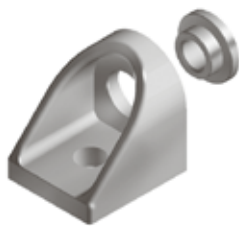
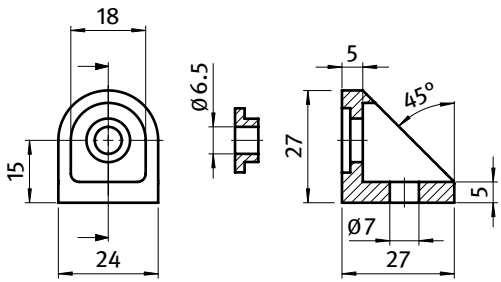

Gelenkwinkel Adjustable Angle		Gewicht [g] Weight [g]	Teil-Nr. Part #
	blank Plain	40.0	093WG301R
	alufarbig Alu color	40.0	093WG301A

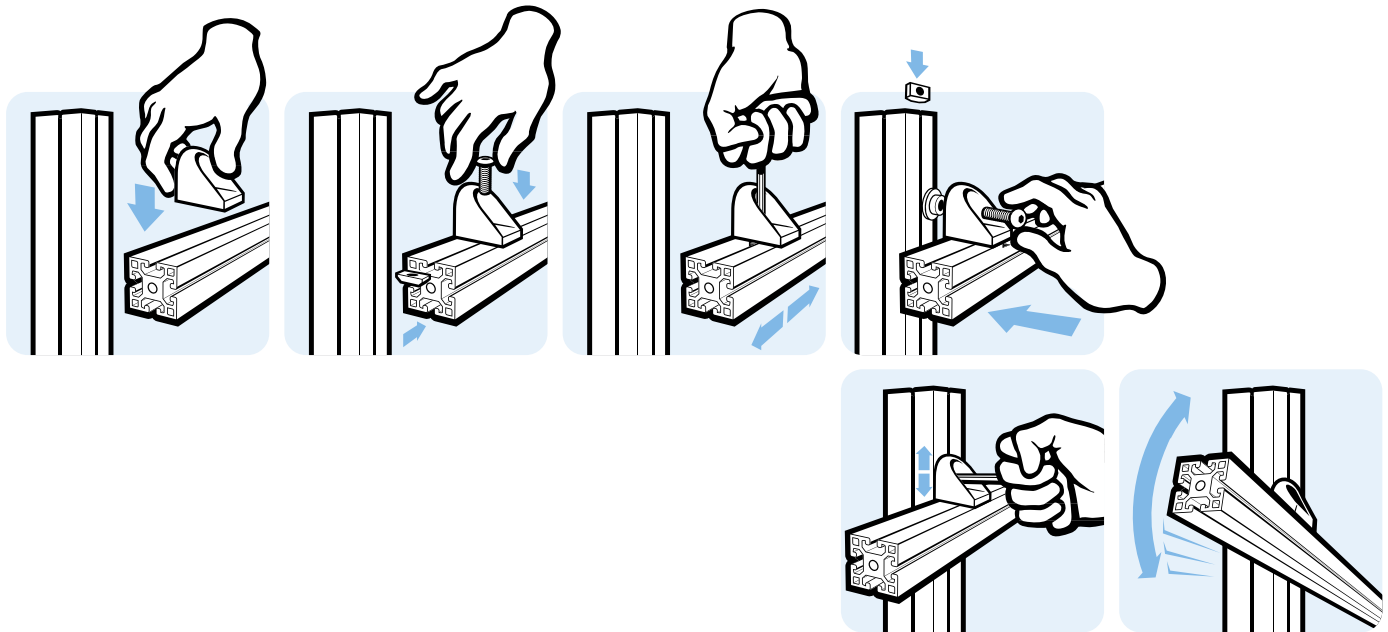



GELENKWINKEL 40

ADJUSTABLE ANGLE 40

Ausführung	Zinkdruckguss	Model	Zinc die-cast
Beschreibung	zur Verbindung von zwei Aluminium-Profilen in verschiedenen Winkeln, durch die Lagerbuchse auch im montierten Zustand frei drehbar	Description	To connect aluminum profiles at various angles; can be turned freely when mounted
Material	Winkel: Zinkdruckguss Buchse: Stahl, verzinkt	Material	Angle: Zinc die-cast Bushing: Steel, zinc plated
Befestigung	mit Schrauben M8	Fastening	Using M8 screws
Liefereinheit	10 Stück	Pack Quantity	10 pieces
Extras	weitere Oberflächen, weitere Farben auf Anfrage	Specials	Other surfaces, other colors on request

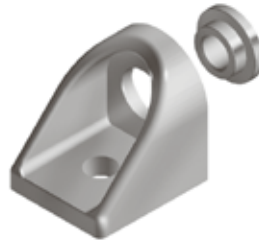
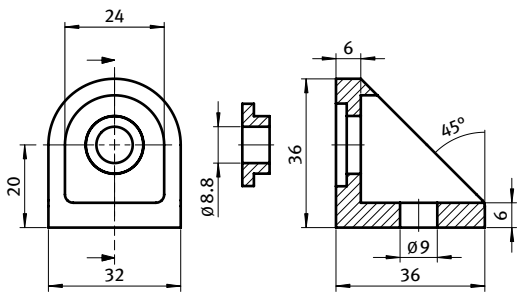

Gelenkwinkel
Adjustable Angle

Gewicht [g]
Weight [g]

Teil-Nr.
Part #

blank <i>Plain</i>	91.0	093WG401R
alufarbig <i>Alu color</i>	91.0	093WG401A

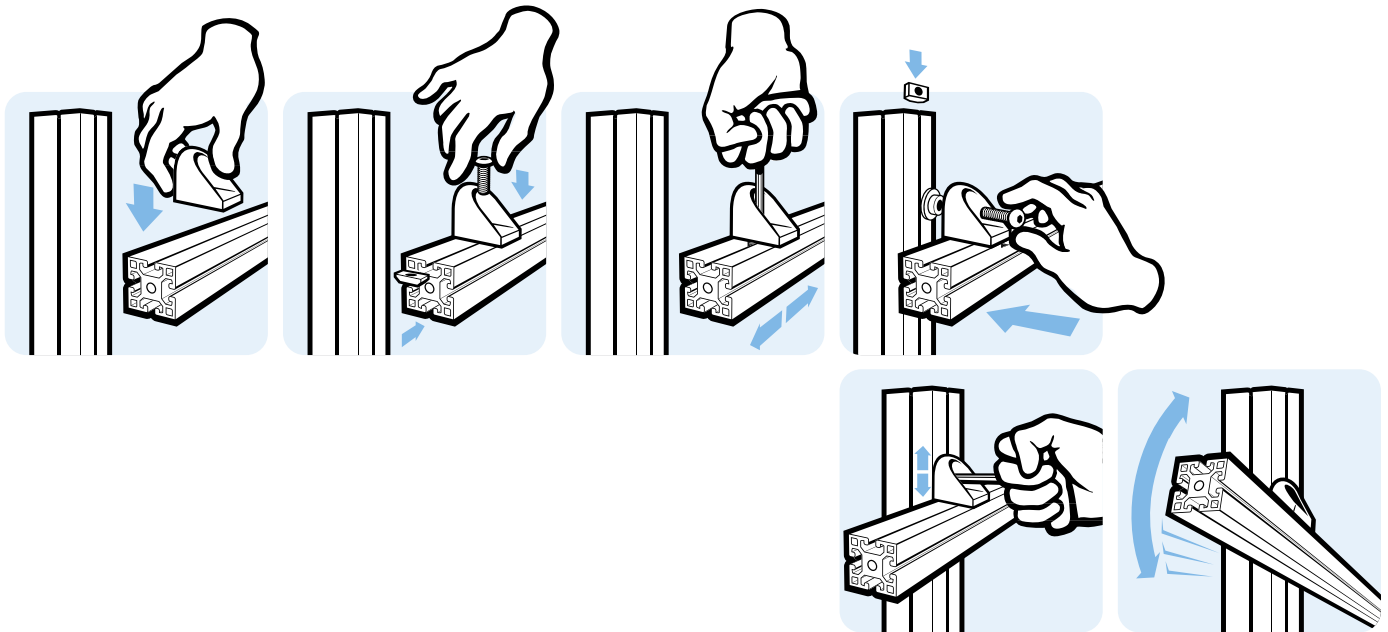



DREHWINKEL 30

TURNING ANGLE 30

Ausführung	Aluminiumdruckguss	Model	Aluminum die-cast
Beschreibung	zur Verbindung von zwei Aluminiumprofilen in verschiedenen Winkeln zwischen 0° und 180°	Description	To connect aluminum profiles at various angles from 0° to 180°
Material	Drehwinkel: Aluminiumdruckguss Nutfixierung: Kunststoff PA, glasfaserverstärkt Montageset: Stahl	Material	Angle: Aluminum die-cast Centering piece: Plastic PA, glass fiber reinforced Assembly set: Steel
Farbe	Nutfixierung: schwarz	Color	Centering piece: Black
Montageset 2	2 Schrauben DIN 7984 - M8 × 16, 2 Hammermüttern - Nut 10 - M8, 4 Nutfixierungen - Nut 8 auf Nut 10	Assembly Set 2	2 screws DIN 7984 - M8 × 16, 2 hammer nuts - slot 10 - M8, 4 centering pieces - Slot 8 to slot 10
Liefereinheit	10 Stück	Pack Quantity	10 pieces

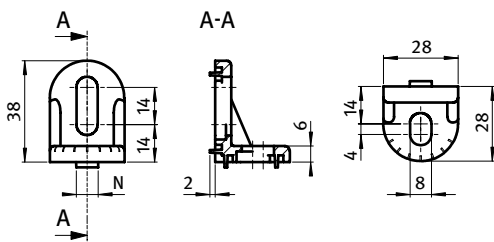

Drehwinkel <i>Turning Angles</i>		N	Gewicht [g] <i>Weight [g]</i>	Teil-Nr. <i>Part #</i>
blank <i>Plain</i>		8	16.8	093WG302N08
		10	17.2	093WG302N10
alufarbig <i>Alu color</i>		8	17.0	093WG302N08S04
		10	20.0	093WG302N10S03
Nutfixierung <i>Centering piece</i>	Nut 8 auf Nut 10 <i>Slot 8 to slot 10</i>		1.0	093W02
blank inkl. Montageset 1 <i>Plain incl. assembly set 1</i>		8 / 10	42.0	093WG302N08S05
blank inkl. Montageset 2 <i>Plain incl. assembly set 2</i>		10	47.4	093WG302N10S01
alufarbig inkl. Montageset 1 <i>Alu color incl. assembly set 1</i>		8 / 10	42.4	093WG302N08S06
alufarbig inkl. Montageset 2 <i>Alu color incl. assembly set 2</i>		10	48.0	093WG302N10S02

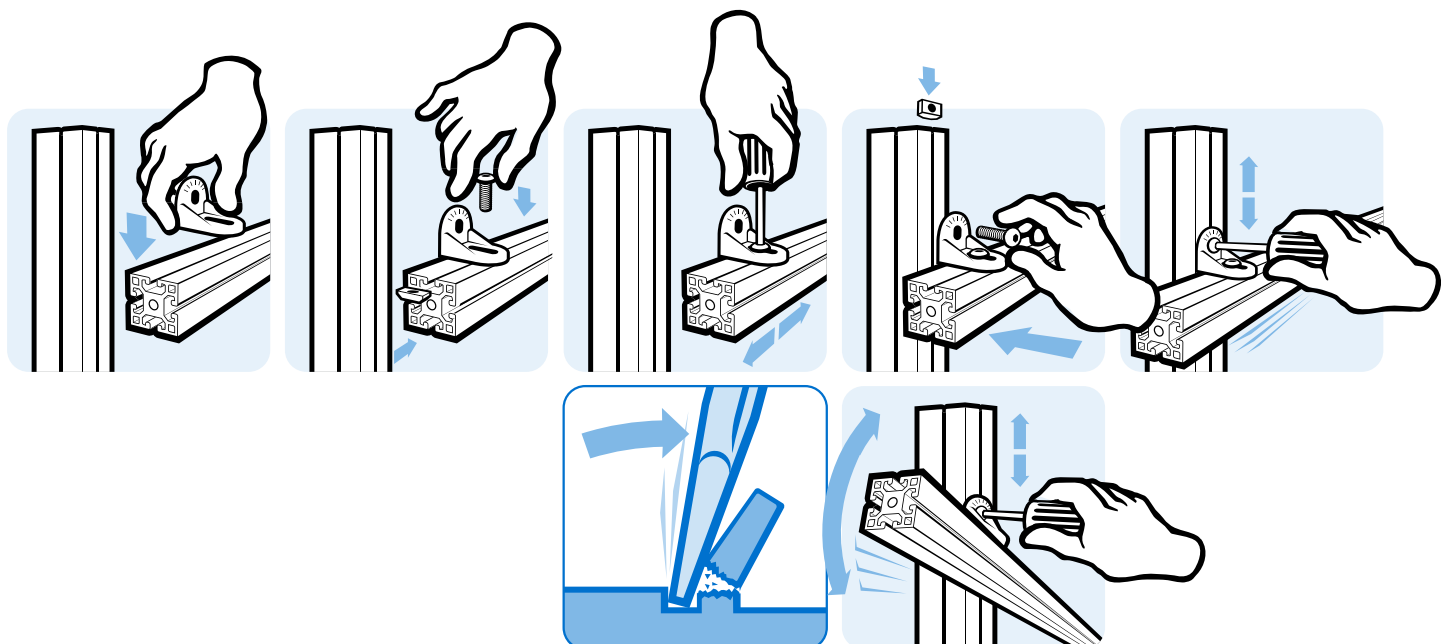



DREHWINKEL 45

TURNING ANGLE 45

Ausführung	Aluminiumdruckguss	Model	Aluminum die-cast
Beschreibung	zur Verbindung von zwei Aluminiumprofilen in verschiedenen Winkeln zwischen 0° und 180°	Description	To connect aluminum profiles at various angles from 0° to 180°
Material	Drehwinkel: Aluminiumdruckguss Zentrierbolzen: Kunststoff PA, glasfaserverstärkt Montageset: Stahl	Material	Turning Angle: Aluminum die-cast Centering bolts: Plastic PA, glass fiber reinforced Assembly set: Steel
Farbe	Zentrierbolzen: schwarz	Color	Centering bolts: Black
Montageset	5 Schrauben DIN 7991 - M8 × 20, 2 Hammermuttern - Nut 10 - M8	Assembly Set	5 screws DIN 7991 - M8 × 20, 2 hammer nuts - slot 10 - M8
Liefereinheit	10 Stück	Pack Quantity	10 pieces

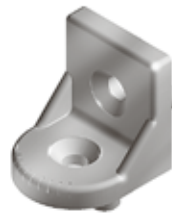
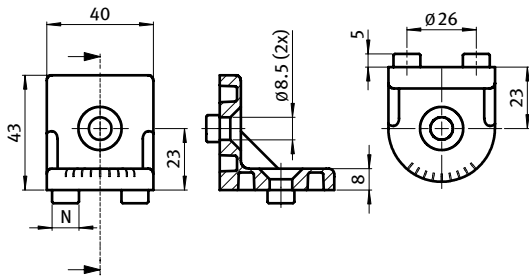

Drehwinkel Turning Angles	N	Gewicht [g] Weight [g]	Teil-Nr. Part #
		44.2	093WG402
	8 / 10	45.0	* 093WG402N
blank inkl. Montageset <i>Plain incl. assembly set</i>	8 / 10	76.0	* 093WG402NS02
alufarbig inkl. Montageset <i>Alu color incl. assembly set</i>	8 / 10	77.0	* 093WG402NS03

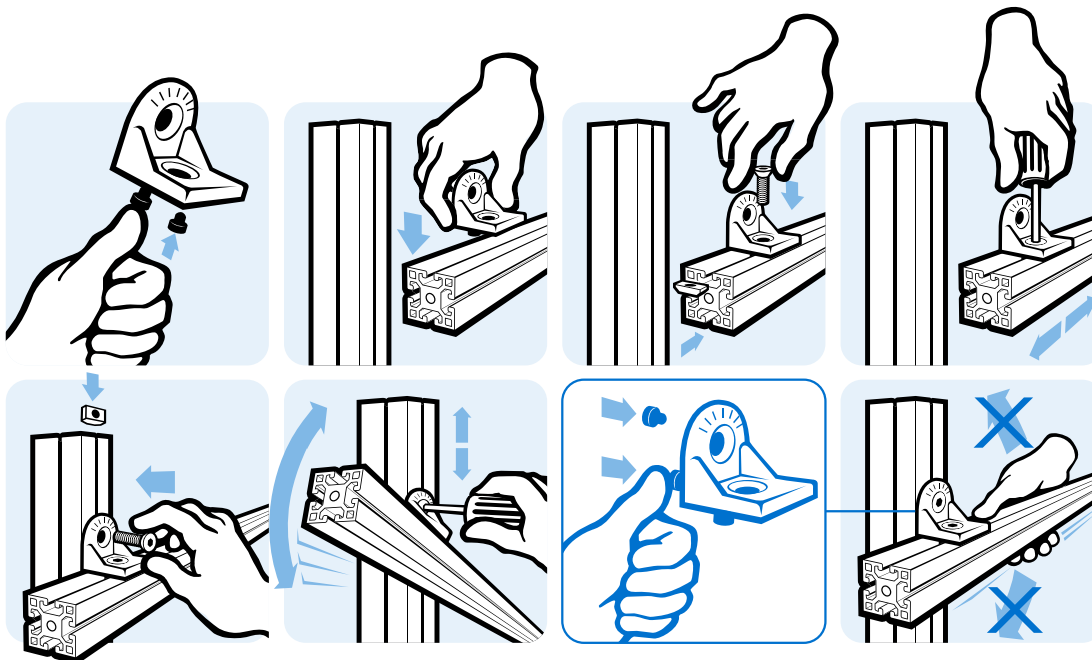



WINKELFESTSTELLUNG 40/80 (SET)

ANGLE LOCKING BRACKET 40/80 (SET)

<p>Ausführung Aluminiumdruckguss</p> <p>Beschreibung zur winkelverstellbaren Verbindung von zwei Alumium-Profilen, mittels Rändelschraube in 2,5° Schritten fixierbar</p> <p>Material Winkelgehäuse: Aluminiumdruckguss Rändelschraube: Kunststoff PA, glasfaserverstärkt Befestigungsmaterial: Stahl</p> <p>Farbe Rändelschraube: schwarz</p> <p>Set 1 Winkelfeststellung inkl. Rändelschraube, 2 Schrauben DIN 7984 - M8 × 18, 2 Schrauben ISO 7380 - M8 × 18, 2 Scheiben DIN 125 - 8.4, 4 Nutensteine - Nut 8 - M8</p> <p>Liefereinheit 10 Stück</p>	<p>Model Aluminum die-cast</p> <p>Description To connect aluminum profiles at an adjustable angle, can be fixed in 2.5° steps by means of a knurled screw</p> <p>Material Body: Aluminum die-cast Knurled screw: Plastic PA, glass fiber reinforced Assembly material: Steel</p> <p>Color Knurled screw: Black</p> <p>Set 1 angle locking bracket incl. knurled screw, 2 screws DIN 7984 - M8 × 18, 2 screws ISO 7380 - M8 × 18, 2 shims DIN 125 - 8.4, 4 T-slot nuts - slot 8 - M8</p> <p>Pack Quantity 10 pieces</p>
---	--

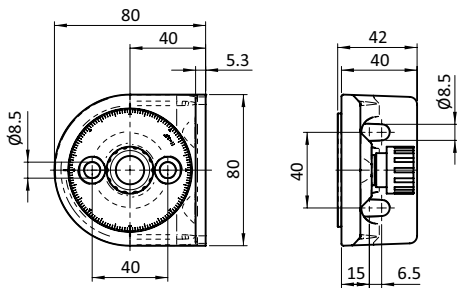

Winkelfeststellung 40/80 (Set)
Angle Locking Bracket 40/80 (Set)

Gewicht [g]
Weight [g]

Teil-Nr.
Part #

275.0

093WG403

SCHWENKWINKEL 130

PIVOT ANGLE 130

Ausführung	Stahl	Model	Steel
Beschreibung	zur winkelverstellbaren Verbindung von zwei Aluminium-Profilen, mittels Klemmhebel fixierbar	Description	To connect aluminum profiles at an adjustable angle; can be fixed with a locking lever
Material	Stahl	Material	Steel
Liefereinheit	10 Stück	Pack Quantity	10 pieces
Extras	weitere Oberflächen, weitere Farben auf Anfrage	Specials	Other surfaces, other colors on request

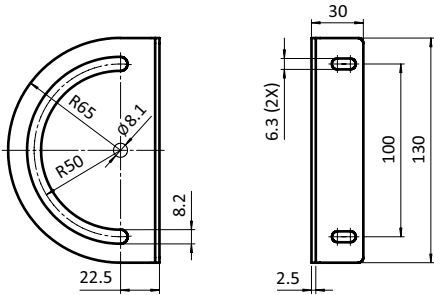

Schwenkwinkel Pivot Angle	für Klemmhebel for Locking Lever	für Schraube for Screw	Gewicht [g] Weight [g]	Teil-Nr. Part #
	M8	M6	221.0	093WG130V

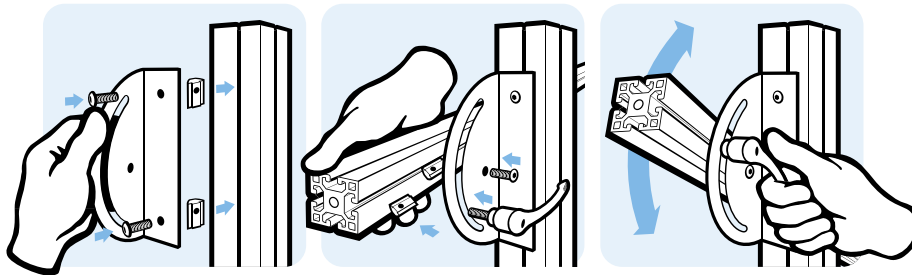



STRECKENVERBINDER 50, NUT 8

CONNECTING STRIP 50, SLOT 8

Ausführung	Stahl	Model	Steel
Beschreibung	zur stirnseitigen Verbindung von zwei Aluminiumprofilen ohne Profilbearbeitung	Description	End-to-end connection of two aluminum profiles without machining
Material	Stahl, verzinkt	Material	Zinc plated steel
Set 1	1 Streckenverbinder 50, Nut 8, 2 Schrauben ISO 7380 Form B - M6 × 8, 2 Scheiben DIN 125	Set 1	1 connecting strip 50, slot 8, 2 screws ISO 7380 Form B - M6 × 8, 2 washers DIN 125
Set 2	2 Streckenverbinder 50, Nut 8, 2 Schrauben DIN 913 - M6 × 10	Set 2	2 connecting strip 50, slot 8, 2 screws DIN 913 - M6 × 10
Liefereinheit	10 Stück	Pack Quantity	10 pieces

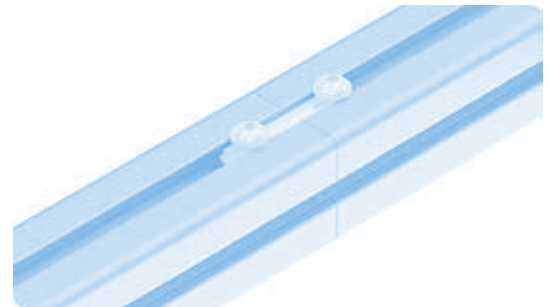
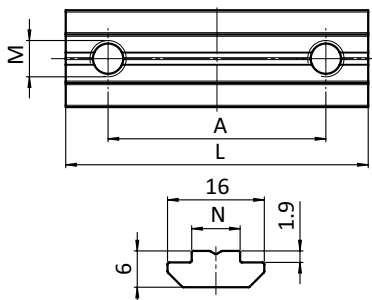

Streckenverbinder 50, Nut 8 Connecting Strip 50, slot 8	A [mm]	L [mm]	N	Größe Size	Gewicht [g] Weight [g]	Profil Profile	Teil-Nr. Part #
Set 1	36.0	50.0	8	M6	35.0	B	096010S46
Set 2	36.0	50.0	8	M6	29.0	B	096010S05



SET STRECKENVERBINDER 180, NUT 8

SET CONNECTING STRIP 180, SLOT 8

Ausführung	Stahl	Model	Steel
Beschreibung	zur stirnseitigen Verbindung von zwei Aluminiumprofilen ohne Profilbearbeitung	Description	End-to-end connection of two aluminum profiles without machining
Material	Stahl, verzinkt	Material	Zinc plated steel
Set	1 Streckenverbinder 180 - Nut 8, 4 Schrauben DIN 912 - M6 × 12, 4 Scheiben DIN 7349 - 6.4	Set	1 connecting strip 180, slot 8, 4 screws DIN 912 - M6 × 12, 4 washers DIN 7349 - 6.4
Liefereinheit	10 Stück	Pack Quantity	10 pieces

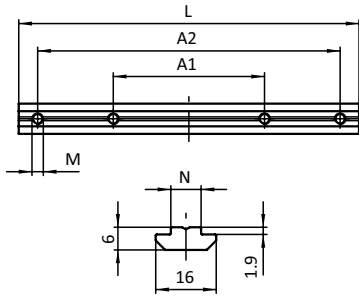

Set Streckenverbinder 180 Set Connecting Strip 180	A1 [mm]	A2 [mm]	L [mm]	N	Größe Size	Gewicht [g] Weight [g]	Profil Profile	Teil-Nr. Part #
	80.0	160.0	180.0	8	M6	134.0	B	096010S11

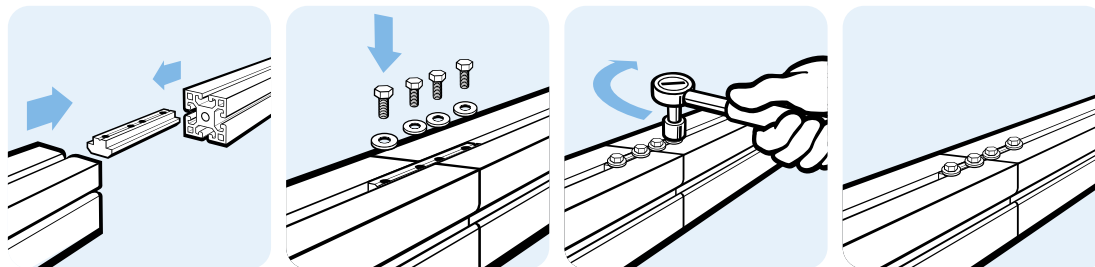



SET STRECKENVERBINDER 180, NUT 10

SET CONNECTING STRIP 180, SLOT 10

Ausführung	Stahl	Model	Steel
Beschreibung	zur stirnseitigen Verbindung von zwei Aluminiumprofilen ohne Profilbearbeitung	Description	End-to-end connection of two aluminum profiles without machining
Material	Stahl, verzinkt	Material	Zinc plated steel
Set	1 Streckenverbinder 180, Nut 10, 4 Schrauben DIN 933 (ISO 4017) - M8 x 16, 4 Scheiben 8-FSt, 4 Scheiben DIN 7349 - 8.4	Set	1 connecting strip 180, slot 10, 4 screws DIN 933 (ISO 4017) - M8 x 16, 4 washers 8-FSt, 4 washers DIN 7349 - 8.4
Liefereinheit	10 Stück	Pack Quantity	10 pieces

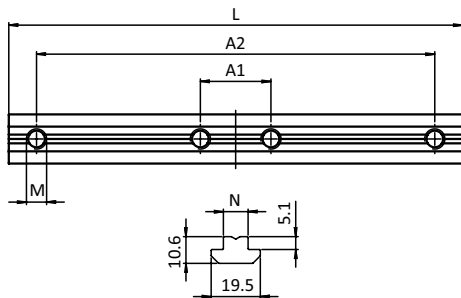

Set Streckenverbinder 180 Set Connecting Strip 180	A1 [mm]	A2 [mm]	L [mm]	N	Größe Size	Gewicht [g] Weight [g]	Profil Profile	Teil-Nr. Part #
	28.0	158.0	180.0	10	M8	264.0	B	096030S38

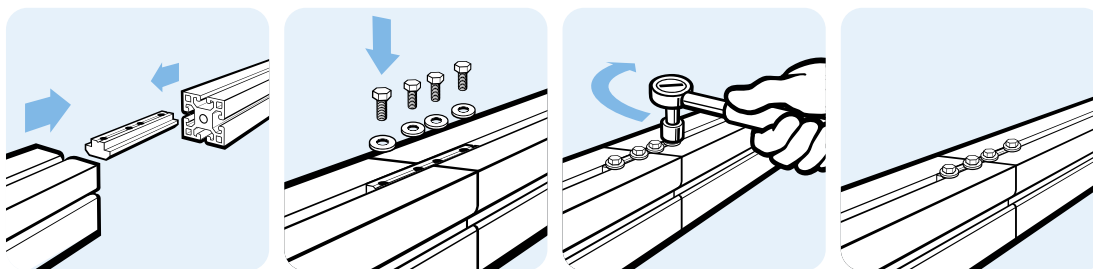



VERSTIFTUNGSNUTENSTEIN M6

PIN T-SLOT NUT M6

<p>Ausführung Stahl, Nut 8</p> <p>Beschreibung erhöht die Belastbarkeit einer Verbindung gegen Verschiebungen; es muss ein Ø 5,9 mm Loch in eines der Profile gebohrt werden</p> <p>Material Verstiftungsnutenstein: Stahl, verzinkt Zylinderstift DIN 7979 D6 m6 × 16: Stahl Gewindesttift DIN 916 M6 × 12: Stahl, verzinkt</p> <p>Liefereinheit 10 Stück</p>	<p>Model Steel, slot 8</p> <p>Description To enhance the stability of a connection against displacement; a Ø 5.9 mm hole must be drilled into one profile</p> <p>Material Pin T-slot nut: Zinc plated steel Straight pin DIN 7979 D6 m6 × 16: Steel Hexagon socket set screw DIN 916 M6 × 12: Zinc plated steel</p> <p>Pack Quantity 10 pieces</p>
--	--

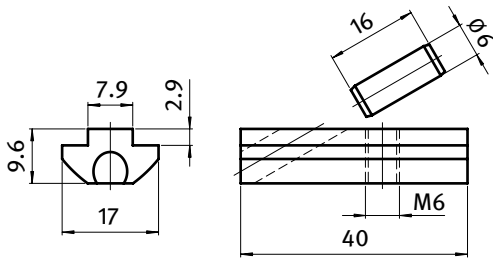

Verstiftungsnutenstein M6 <i>Pin T-slot Nut M6</i>	Nut 8 <i>Slot 8</i>	Gewicht [g] <i>Weight [g]</i>	Profil <i>Profile</i>	Teil-Nr. <i>Part #</i>
	8	35.6	I	096060S13

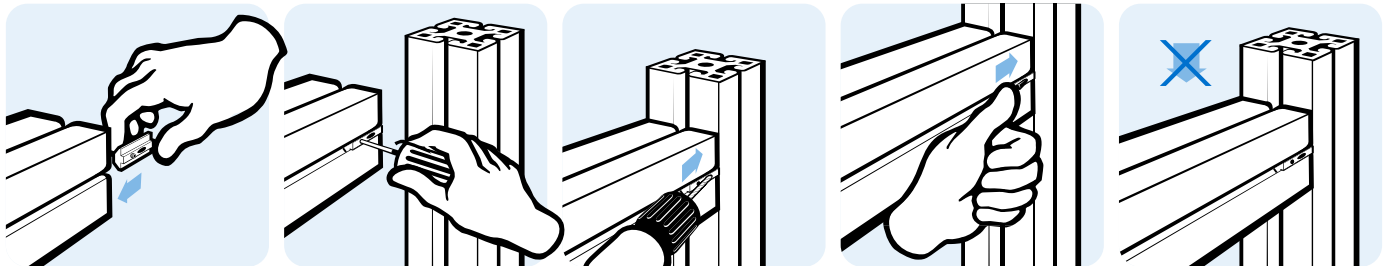







GEHRUNGSVERBINDER 30°-90°, NUT 10

MITRE CONNECTOR 30°-90°, SLOT 10

Ausführung Stahl, Profil 45, Nut 10 tief

Model Steel, profile 45, slot 10 deep

Beschreibung zur Verbindung eines auf Gehrung gesägten Aluminiumprofils (Gehrungsschnitt $\gamma = 30^\circ - 90^\circ$) mit einem Aluminiumprofil; zur Montage muss ein Loch mit $\varnothing 8,2$ mm seitlich gebohrt werden; inklusive Nutenstein und Gewindestift mit SW 4

Description End-to-end connection of an aluminum profile with a mitre cut (cut $\gamma = 30^\circ - 90^\circ$) to another aluminum profile; before the application a hole with $\varnothing 8.2$ mm lateral must be drilled; with T-slot nut and threaded pin with AF 4

Material Stahl

Material Steel

Liefereinheit 10 Stück

Pack Quantity 10 pieces

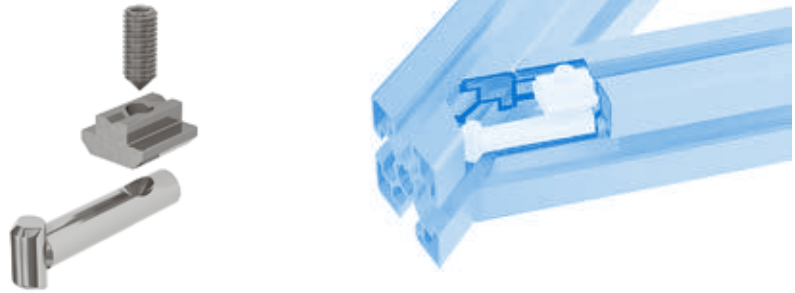
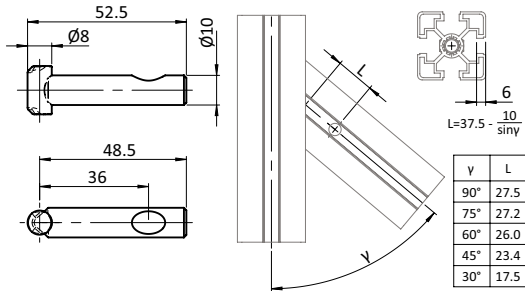

Gehrungsverbinder 30°-90°, Nut 10
Mitre Connector 30°-90°, slot 10

N

Gewicht [g]
Weight [g]

Profil
Profile

Teil-Nr.
Part #

10

57.0

B

099BG10081090

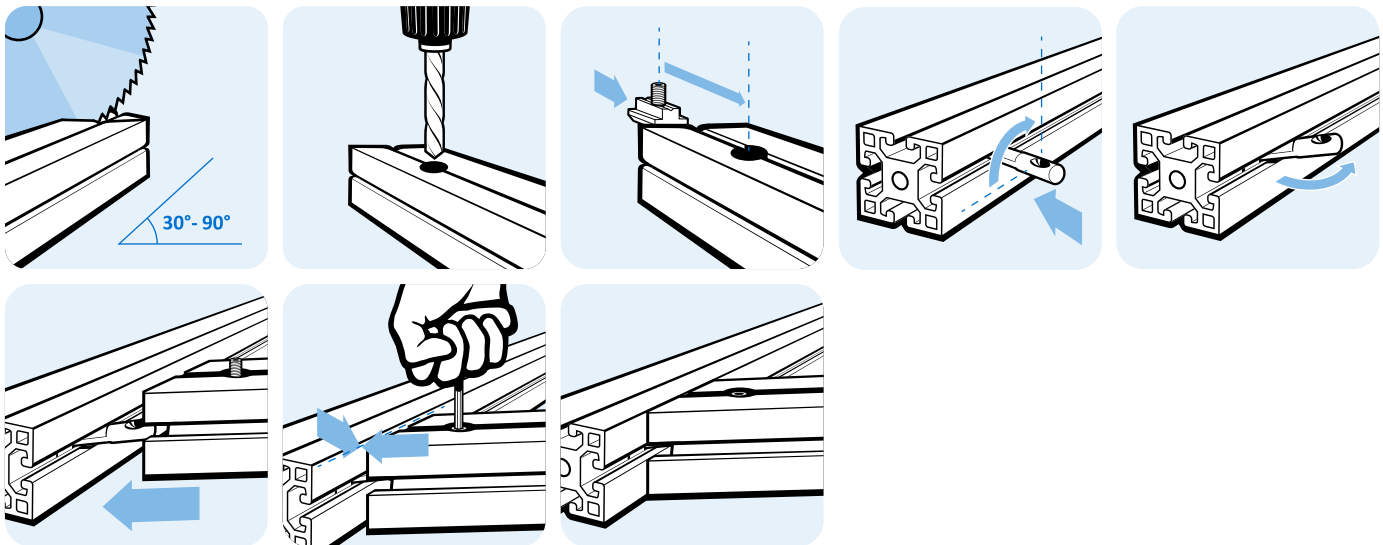



GEHRUNGSVERBINDER 30°-180°, NUT 10

MITRE CONNECTOR 30°-180°, NUT 10

<p>Ausführung Stahl, Nut 10</p> <p>Beschreibung zur Stoß-Verbindung von zwei auf Gehrung gesägten Aluminiumprofilen (Gehrungsschnitt jeweils $\gamma = 30^\circ - 90^\circ$); zur Montage muss je ein Loch mit $\varnothing 8,2$ mm im Abstand von 34 mm vom Profilende gebohrt werden; inklusive Nutenstein und Gewindestift mit SW 4</p> <p>Material Stahl</p> <p>Liefereinheit 10 Stück</p>	<p>Model Steel, slot 10</p> <p>Description End-to-end connection of two aluminum profiles with a mitre cut (cut each $\gamma = 30^\circ - 90^\circ$); before the application a hole with $\varnothing 8.2$ mm in a distance of 34 mm of the profile end must be drilled; with T-slot nut and threaded pin with AF 4</p> <p>Material Steel</p> <p>Pack Quantity 10 pieces</p>
--	--

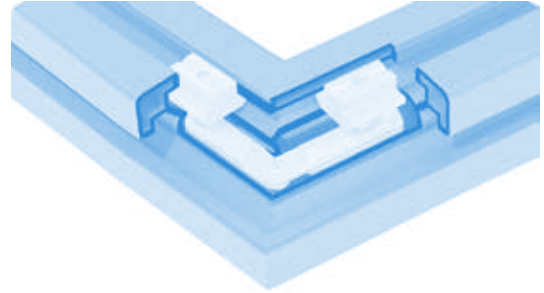
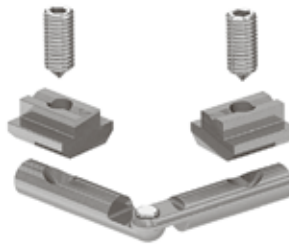
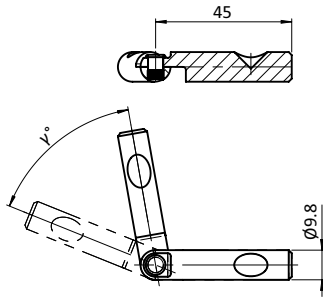

Gehrungsverbinder 30°-180°, Nut 10
Mitre Connector 30°-180°, Nut 10

N

Gewicht [g]
Weight [g]

Profil
Profile

Teil-Nr.
Part #

10

96.0

B

099BG100810180

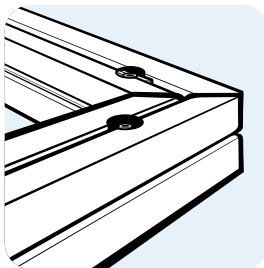
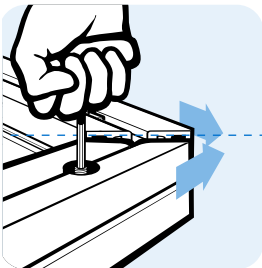
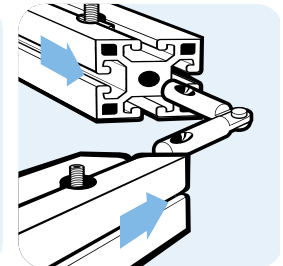
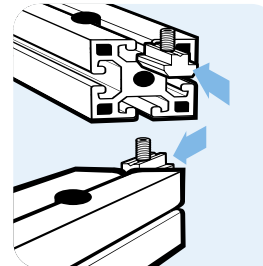
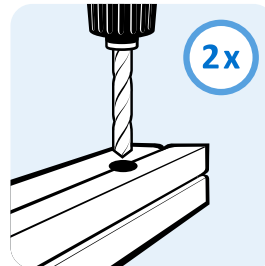
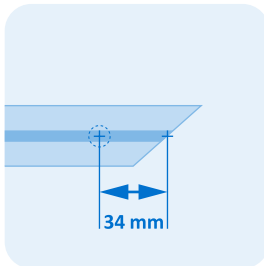
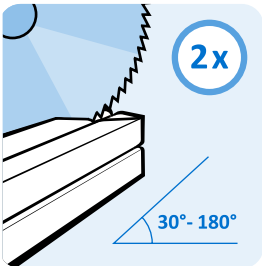



UNI-GEHRUNGS-STOßVERBINDER

UNIVERSAL MITRE BUTT CONNECTOR

Ausführung	Zinkdruckguss, Nut 8	Model	Zinc die-cast, slot 8
Beschreibung	zur Stoß-Verbindung von zwei Aluminiumprofilen mit Gehrungsschnitt	Description	End-to-end connection of two aluminum profiles with a mitre cut
Material	Zinkdruckguss	Material	Zinc die-cast
Set	1 Gehrungsverbinder, 2 Schrauben ISO 7380 - M6 × 35	Set	1 mitre connector, 2 screws ISO 7380 - M6 × 35
Liefereinheit	10 Stück	Pack Quantity	10 pieces



Uni-Gehrungs-Stoßverbinder <i>Universal Mitre Butt Connector</i>	N	Gewicht [g] <i>Weight [g]</i>	Teil-Nr. <i>Part #</i>
Set	8	104.0	099A0840W45

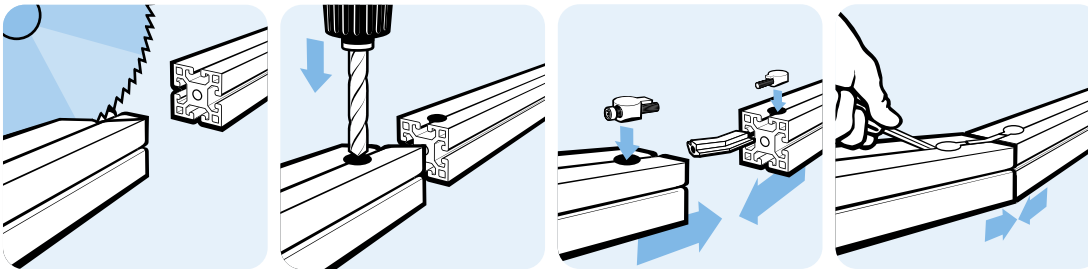



GEHRUNGSVERBINDER 90°

MITRE CONNECTOR 90°

Ausführung Stahl	Model Steel
Beschreibung zur Verbindung von zwei Aluminiumprofilen	Description To connect two aluminum profiles
Material Stahl	Material Steel
Liefereinheit 10 Stück	Pack Quantity 10 pieces

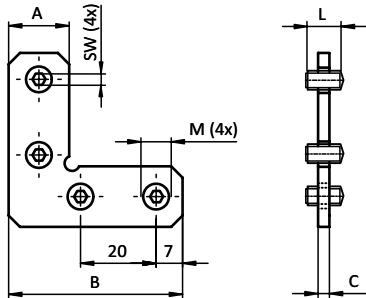

Gehrungsverbinder 90° Mitre Connector 90°	Gewindestift Hexagon socket set screw	A [mm]	B [mm]	C [mm]	L [mm]	SW	Gewicht [g] Weight [g]	Teil-Nr. Part #
	M8	16.0	46.0	3.0	8.0	4	33.0	099GV0890
	M10	20.2	60.0	3.0	10.0	5	59.0	099GV1090

4



GEHRUNGSVERBINDER

MITRE CONNECTOR

Ausführung Stahl	Model Steel
Beschreibung zur Verbindung von zwei Aluminiumprofilen	Description To connect two aluminum profiles
Material Stahl	Material Steel
Liefereinheit 10 Stück	Pack Quantity 10 pieces

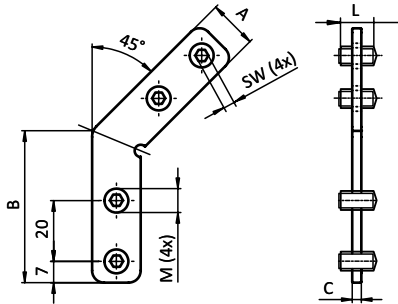

Gehrungsverbinder <i>Mitre Connectors</i>	Gewindestift <i>Hexagon socket set screw</i>	A [mm]	B [mm]	C [mm]	L [mm]	SW	Gewicht [g] <i>Weight [g]</i>	Teil-Nr. <i>Part #</i>
	M8	16.0	46.0	3.0	8.0	4	40.0	099GV0845
	M10	20.2	60.0	3.0	10.0	5	64.5	099GV1045



RADIENDICHTUNG 40 × 40

RADIUS SEAL 40 × 40

Ausführung	Kunststoff PA	Model	Plastic PA
Beschreibung	zum Herstellen eines Übergangs bei rechtwinkligen Profilverbindungen, besonders für Reinraum-Anwendungen geeignet	Description	To seal the transition between two profiles at a tee connection, especially for clean room applications
Material	Kunststoff PA, glasfaserverstärkt	Material	Plastic PA, glass fiber reinforced
Farbe	grau ≈RAL 7042	Color	gray ≈RAL 7042
Liefereinheit	100 Stück	Pack Quantity	100 pieces
Extras	weitere Farben auf Anfrage	Specials	Other colors on request

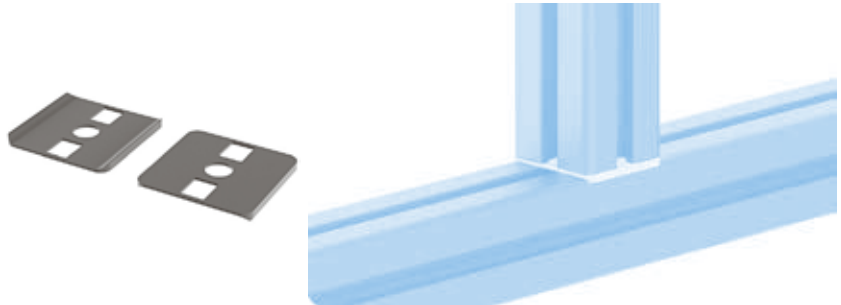
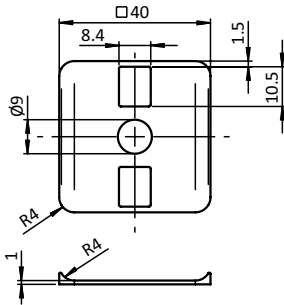

Radiendichtung 40 × 40
Radius Seal 40 × 40

Gewicht [g]
Weight [g]

Profil
Profile

Teil-Nr.
Part #

2.0

I

093RD84040R4

INHALTSÜBERSICHT *CONTENT OVERVIEW*



Bodenelemente <i>Floor Elements</i>	1
Scharniere <i>Hinges</i>	2
Nutmuttern und -schrauben <i>T-Nuts and T-Bolts</i>	3
Verbindungstechnik <i>Connecting Systems</i>	4
Griffe und Verschlüsse <i>Handles and Latches</i>	5
Arbeitsplatzkomponenten <i>Components for Work Stations</i>	6
Gleiter und Rollen <i>Sliders and Rollers</i>	7
Fördertechnik <i>Conveyors</i>	8
Schutz- und Trennwandelemente <i>Enclosures, Guards, Partitions</i>	9
Flächenbefestigungen <i>Panel Fasteners</i>	10
Abdeckelemente <i>Cover Elements</i>	11
Kabelführungen <i>Cable Management</i>	12
Diverse Komponenten <i>Miscellaneous Components</i>	13
Rundrohrkomponenten <i>Tubular Frame Components</i>	14

Griffe und Verschlüsse *Handles and Latches*

Inhaltsverzeichnis *Table of Content*

FATH®

Components



	Frontwinkelgriff	<i>Front Handle</i>	527		Magnetverschluss 20	<i>Magnetic Catch 20</i>	548
	Bügelgriff	<i>Bridge Handle</i>	528		Magnetverschluss 30 (Set)	<i>Magnetic Catch 30 (Set)</i>	549
	Bügelgriff	<i>Bridge Handle</i>	529		Befestigungswinkel für Magnetverschluss 30	<i>Angle Bracket for Magnetic Catch 30</i>	550
	Handgriff	<i>Handle</i>	530		Magnet-Verschlussgriff Compact	<i>Magnetic Catch Handle Compact</i>	551
	Bügelgriff B	<i>Bridge Handle B</i>	531		Kugelschnäpper	<i>Ball Catch</i>	552
	Maschinengriff 135	<i>Machine Handle 135</i>	532		Abstandshalter für Kugelschnäpper	<i>Spacer for Ball Catch</i>	553
	Maschinengriff 240	<i>Machine Handle 240</i>	533		Befestigungswinkel für Kugelschnäpper	<i>Angle Bracket for Ball Catch</i>	554
	Comfortgriff	<i>Comfort Handle</i>	534		Türschnäpper (Set)	<i>Door Latch (Set)</i>	555
	Endstücke für Systemgriff	<i>End Pieces for System Handle</i>	535		Doppelkugelschnäpper PA	<i>Double Ball Catch PA</i>	556
	Griffstange für Systemgriff	<i>Tubes for System Handle</i>	536		Doppelkugelschnäpper MS	<i>Double Ball Catch MS</i>	557
	Griffleiste	<i>Strip Handle</i>	537		Riegel	<i>Door Latch</i>	558
	Fallenverschluss	<i>Slam Latch</i>	538		Türanschlag mit EPDM-Dämpfer (Set)	<i>Door Stop with EPDM Damper (Set)</i>	559
	Fallenverschluss Compact	<i>Slam Latch Compact</i>	540		Türanschlag mit Magnetverschuß (Set)	<i>Door Stop with Magnetic Catch (Set)</i>	560
	Twin-Fallenverschluss Compact	<i>Twin Slam Latch Compact</i>	541		Dichtleiste	<i>Sealing Strip</i>	561
	Schiebetürverschluss Compact	<i>Slide Door Latch Compact</i>	542				
	Fallenverschluss PRO	<i>Slam Latch PRO</i>	543				
	Fallenverschluss PROe	<i>Slam Latch PROe</i>	545				
	Notöffner für Fallenverschluss	<i>Emergency Opener for Slam Latch</i>	546				
	Türschlösser	<i>Door Locks</i>	547				

FRONTWINKELGRIFF

FRONT HANDLE

Ausführung	Kunststoff PA	Model	Plastic PA
Beschreibung	zur Montage auf Türen, Klappen und Aluminiumprofile	Description	To mount on doors, flaps and aluminum profiles
Material	Kunststoff PA, glasfaserverstärkt	Material	Plastic PA, glass fiber reinforced
Farbe	schwarz	Color	Black
Befestigung	vorderseitig mit Senkschrauben	Fastening	From the front, using countersunk screws
Liefereinheit	10 Stück	Pack Quantity	10 pieces
Extras	☁ elektrostatisch entladend, weitere Größen, weitere Farben auf Anfrage	Specials	☁ electrostatically discharging, other sizes, other colors on request

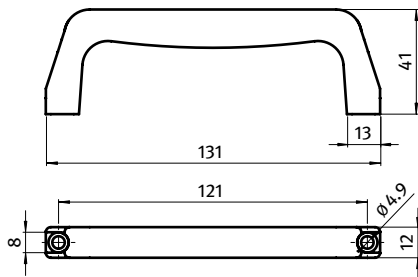

Frontwinkelgriff
Front Handle

für Schraube
for Screw

Gewicht [g]
Weight [g]

Teil-Nr.
Part #

M4

30.0

092005



BÜGELGRIFF

BRIDGE HANDLE

Ausführung	Kunststoff PA, 122 und 152 mm	Model	Plastic PA, 122 and 152 mm
Beschreibung	zur Montage auf Türen, Klappen und Aluminiumprofile	Description	To mount on doors, flaps and aluminum profiles
Material	Kunststoff PA, glasfaserverstärkt	Material	Plastic PA, glass fiber reinforced
Farbe	schwarz	Color	Black
Befestigung	vorderseitig mit Zylinderschrauben, rückseitig mit eingelegter Sechskantmutter oder Sechskantschraube	Fastening	From the front, using socket head screws; from the back using inserted hexagon nuts or hexagon cap screws
Liefereinheit	10 Stück	Pack Quantity	10 pieces
Extras	weitere Farben auf Anfrage	Specials	Other colors on request

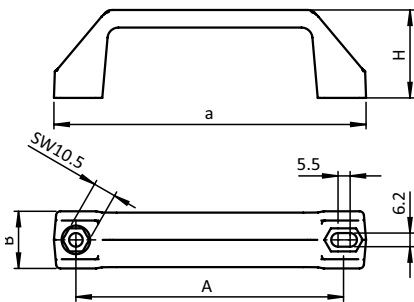

Bügelgriff <i>Bridge Handle</i>	A [mm]	B [mm]	H [mm]	für Mutter <i>for Nut</i>	für Schraube <i>for Screw</i>	Gewicht [g] <i>Weight [g]</i>	Teil-Nr. <i>Part #</i>
122	122.0	26.0	40.0	SW10 (M6)	M6	41.0	092001
152	152.0	28.0	53.5	SW10 (M6)	M6	70.0	092002

5



BÜGELGRIFF

BRIDGE HANDLE

Ausführung	Kunststoff PA, mit Bohrung und Abdeckkappen	Model	Plastic PA, with plain bore and cover caps
Beschreibung	zur Montage auf Türen, Klappen und Aluminiumprofile	Description	To mount on doors, flaps and aluminum profiles
Material	Kunststoff PA, glasfaserverstärkt	Material	Plastic PA, glass fiber reinforced
Farbe	schwarz	Color	Black
Befestigung	vorderseitig mit Zylinderschrauben	Fastening	From the front, using socket head screws
Liefereinheit	10 Stück	Pack Quantity	10 pieces
Extras	weitere Farben auf Anfrage	Specials	Other colors on request

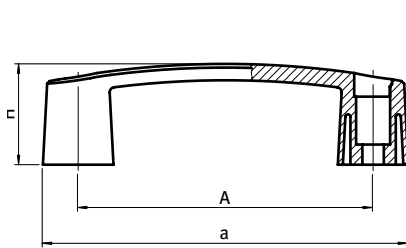

Bügelgriff Bridge Handle	A [mm]	B [mm]	H [mm]	für Schraube for Screw	Gewicht [g] Weight [g]	Teil-Nr. Part #
94	94.0	17.0	35.0	M6	32.0	12093B65
117	117.0	19.0	40.0	M8	48.0	12117B85
132	132.0	20.0	45.0	M8	58.0	12132B85
180	179.0	22.0	50.0	M8	87.0	12179B85



HANDGRIFF

HANDLE

Ausführung	Kunststoff PA, 120 und 160 mm	Model	Plastic PA, 120 and 160 mm
Beschreibung	zur Montage auf Türen, Klappen und Aluminiumprofile	Description	To mount on doors, flaps and aluminum profiles
Material	Kunststoff PA, glasfaserverstärkt	Material	Plastic PA, glass fiber reinforced
Farbe	schwarz, gelb, rot, blau	Color	Black, yellow, red, blue
Befestigung	vorderseitig mit Sechskant- oder Zylinderschrauben, rückseitig mit Sechskantmutter M8 und Schrauben	Fastening	From the front with hexagon cap screws or socket head screws, or from the back using M8 hexagon nuts and bolts
Liefereinheit	10 Stück	Pack Quantity	10 pieces
Extras	weitere Farben auf Anfrage	Specials	Other colors on request

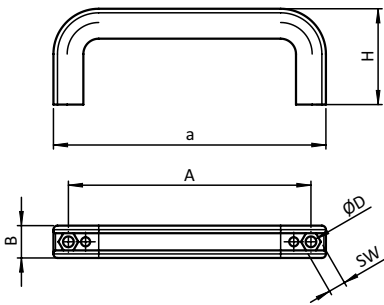

Handgriff <i>Handle</i>	A [mm]	B [mm]	D [mm]	H [mm]	SW	Farben <i>Colors</i>	für Schraube <i>for Screw</i>	Gewicht [g] <i>Weight</i> [g]	Teil-Nr. <i>Part #</i>
120.0	120.0	16.0	5.3	48.0	8.5	schwarz <i>Black</i>	M5	30.0	092012
160.0	160.0	28.0	8.5	60.0	14.0	schwarz <i>Black</i>	M8	91.4	092017
	160.0	28.0	8.5	60.0	14.0	gelb ≈ RAL 1018 <i>Yellow</i>	M8	91.4	092017S02
	160.0	28.0	8.5	60.0	14.0	blau ≈ RAL 5010 <i>Blue</i>	M8	91.4	092017S03
	160.0	28.0	8.5	60.0	14.0	rot ≈ RAL 3020 <i>Red</i>	M8	91.4	092017S04
Abdeckkappe 120 <i>Cover cap 120</i>						schwarz <i>Black</i>		5.7	092019
Abdeckkappe 160 <i>Cover cap 160</i>						schwarz <i>Black</i>		21.4	092018
						gelb ≈ RAL 1018 <i>Yellow</i>		21.4	092018S02
						blau ≈ RAL 5010 <i>Blue</i>		21.4	092018S03
						rot ≈ RAL 3020 <i>Red</i>		21.4	092018S04



5

BÜGELGRIFF B

BRIDGE HANDLE B

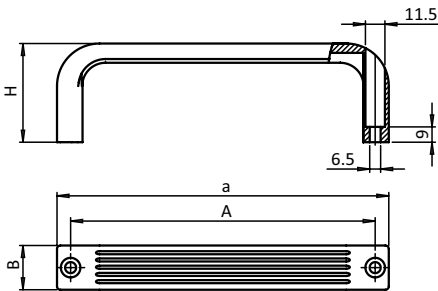
Ausführung	Kunststoff PA	Model	Plastic PA
Beschreibung	zur Montage auf Türen, Klappen und Aluminiumprofile	Description	To mount on doors, flaps and aluminum profiles
Material	Kunststoff PA, glasfaserverstärkt	Material	Plastic PA, glass fiber reinforced
Farbe	schwarz	Color	Black
Befestigung	vorderseitig mit Zylinderschrauben	Fastening	From the front, using socket head screws
Liefereinheit	10 Stück	Pack Quantity	10 pieces
Extras	weitere Farben auf Anfrage	Specials	Other colors on request



Bügelgriff Bridge Handle	A [mm]	B [mm]	H [mm]	ESD	für Schraube for Screw	Gewicht [g] Weight [g]	Teil-Nr. Part #
133	118.0	26.0	50.0		M6	52.9	092308
195	179.0	26.0	58.0		M6	74.4	092307
133	118.0	26.0	50.0		M6	52.0	092308S01
195	179.0	26.0	58.0		M6	65.3	092307S01



MASCHINENGRIF 135

MACHINE HANDLE 135

Ausführung	Kunststoff PA	Model	Plastic PA
Beschreibung	Maschinengriff mit ergonomischer Form und Durchgreifschutz; zur Montage auf Türen, Klappen und Aluminiumprofile; optional mit Abdeckkappen	Description	Machine handle with ergonomic design and finger protection; to mount on doors, flaps and aluminum profiles; optional with cover caps
Material	Kunststoff PA, glaskugelverstärkt	Material	Plastic PA, glass ball reinforced
Farbe	schwarz	Color	Black
Befestigung	mit Sechskant- oder Zylinderschrauben	Fastening	With hexagon cap screws or socket head screws
Liefereinheit	10 Stück	Pack Quantity	10 pieces
Extras	⚡ elektrostatisch entladend, weitere Größen, weitere Farben auf Anfrage	Specials	⚡ electrostatically discharging, other sizes, other colors on request
Hinweis	* Bitte beachten: 1 Set = 2 Stück	Tip	* Please note: 1 set = 2 pieces

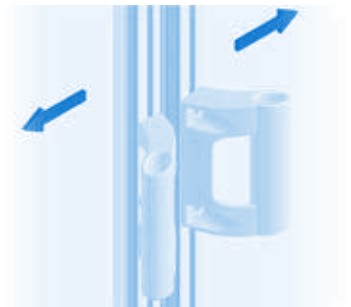
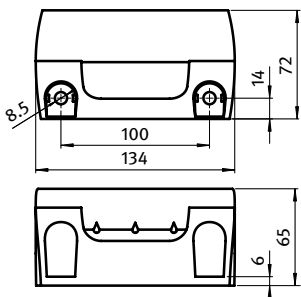

5

Maschinengriff <i>Machine handle</i>	für Schraube <i>for Screw</i>	Gewicht [g] <i>Weight [g]</i>	Teil-Nr. <i>Part #</i>
optional mit Abdeckkappen <i>Optional with cover caps</i>	M8	114.0	092009
Set Abdeckkappen* <i>Set of cover caps*</i>		3.0	*092010

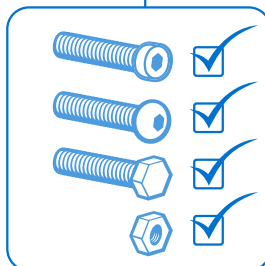
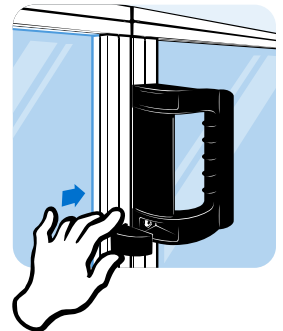
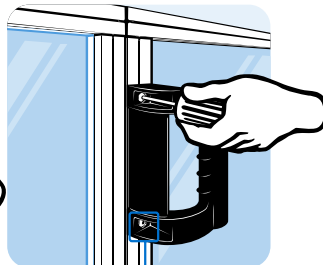
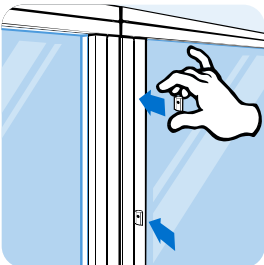



MASCHINENGRIF 240

MACHINE HANDLE 240

Ausführung	Kunststoff PA	Model	Plastic PA
Beschreibung	großer Maschinengriff mit ergonomischer Form und Durchgreifschutz; zur Montage auf Türen, Klappen und Aluminiumprofilen; mit Abdeckkappen	Description	Large machine handle with ergonomic design and finger protection; to mount on doors, flaps and aluminum profiles; with cover caps
Material	Kunststoff PA, glaskugelverstärkt	Material	Plastic PA, glass ball reinforced
Farbe	schwarz	Color	Black
Befestigung	vorderseitig mit Sechskant- oder Zylinderschrauben, rückseitig mit Sechskantmutter M8 und Schrauben	Fastening	From the front with hexagon cap screws or socket head screws, or from the back using M8 hexagon nuts and bolts
Liefereinheit	1 Stück	Pack Quantity	1 piece
Extras	☁ elektrostatisch entladend, weitere Größen, weitere Farben auf Anfrage	Specials	☁ electrostatically discharging, other sizes, other colors on request

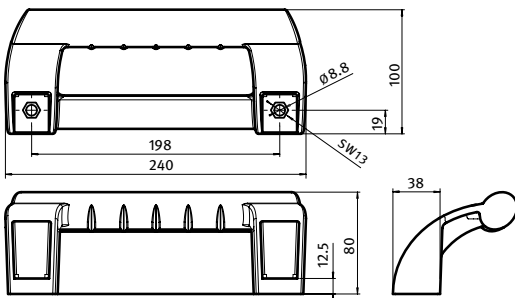

Maschinengriff <i>Machine handle</i>	für Schraube <i>for Screw</i>	Gewicht [g] <i>Weight [g]</i>	Teil-Nr. <i>Part #</i>
mit Abdeckkappen <i>With cover caps</i>	M8	356.0	092008

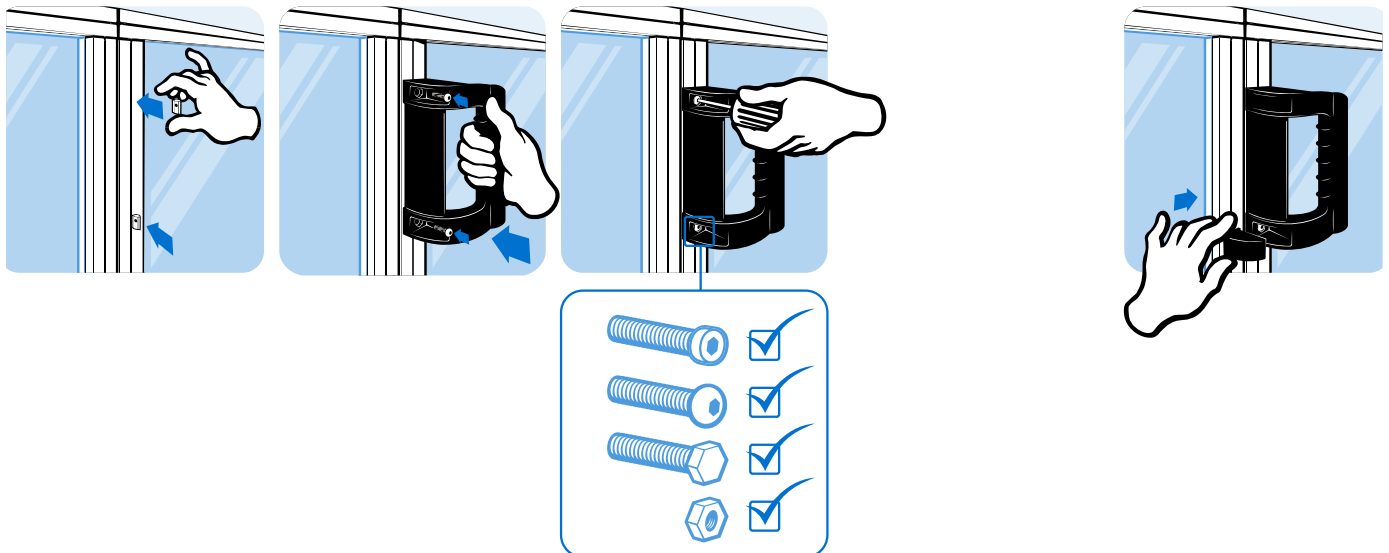



COMFORTGRIF

COMFORT HANDLE

Ausführung	Kunststoff PA, 120, 160 und 200 mm	Model	Plastic PA, 120, 160 and 200 mm
Beschreibung	zur Montage auf Türen, Klappen und Aluminiumprofile	Description	To mount on doors, flaps and aluminum profiles
Material	Kunststoff PA, glaskugelverstärkt	Material	Plastic PA, glass ball reinforced
Farbe	schwarz	Color	Black
Befestigung	vorderseitig mit Innensechskant-Schrauben, rückseitig mit Schrauben und in die Abdeckkappen eingelegten Muttern	Fastening	From the front with hexagon screws, from the back with screws and with nuts inserted into the cover caps
Liefereinheit	10 Stück / Sets	Pack Quantity	10 pieces / sets
Extras	weitere Farben auf Anfrage	Specials	Other colors on request
Hinweis	* Bitte beachten: 1 Set = 2 Stück	Tip	* Please note: 1 set = 2 pieces

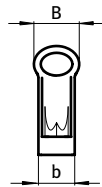
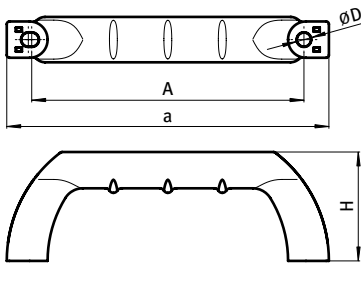

5

Comfortgriff Comfort Handle	A [mm]	B [mm]	D [mm]	H [mm]	für Mutter for Nut	für Schraube for Screw	Gewicht [g] Weight [g]	Teil-Nr. Part #
	120	120.0	20.0	6.2	48.0	M6	26.2	092300
	160	160.0	30.0	8.2	60.0	M8	53.8	092302
	200	200.0	38.0	8.2	75.0	M8	90.6	092304
Set Abdeckkappen 120* Set of cover caps 120*						M6	4.0	092301
Set Abdeckkappen 160* Set of cover caps 160*						M8	10.0	092303
Set Abdeckkappen 200* Set of cover caps 200*						M8	20.0	092305

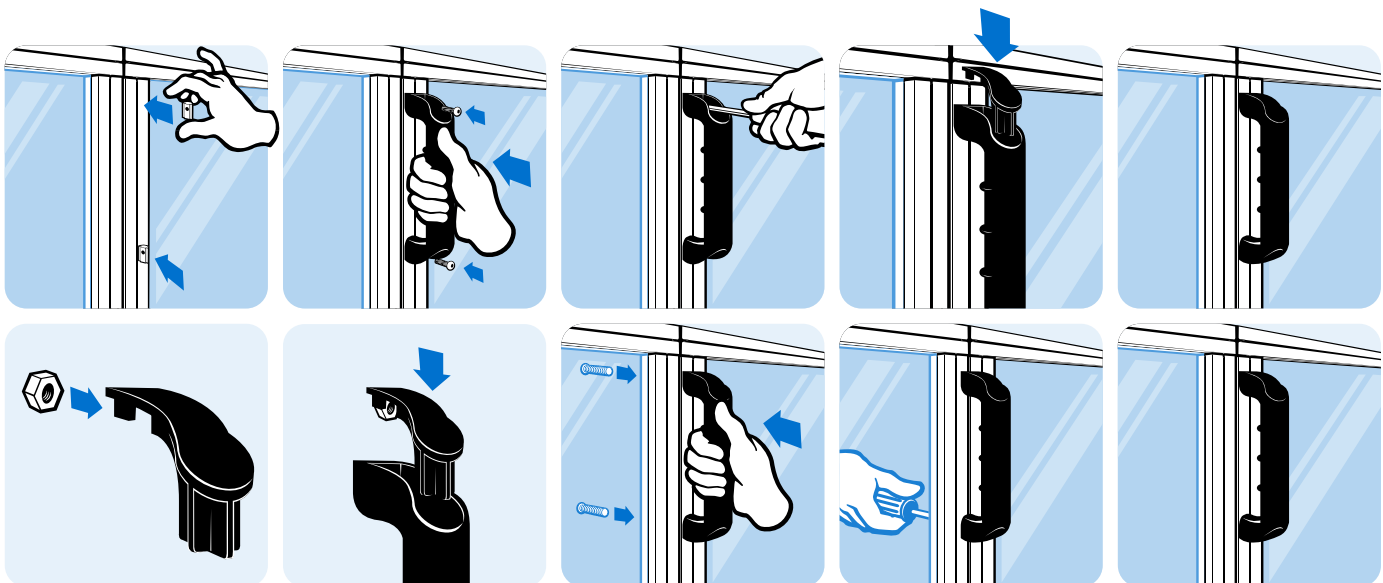

ENDSTÜCKE FÜR SYSTEMGRIFF

END PIECES FOR SYSTEM HANDLE

Ausführung	Kunststoff PA	Model	Plastic PA
Beschreibung	zur Montage auf Türen, Klappen und Aluminium-profile	Description	To mount on doors, flaps and aluminum profiles
Material	Kunststoff PA, glaskugelverstärkt	Material	Plastic PA, glass ball reinforced
Farbe	schwarz	Color	Black
Befestigung	vorderseitig mit Innensechskant-Schrauben, rückseitig mit Schrauben und in die Abdeckkappen eingelegten Muttern M8	Fastening	From the front with hexagon screws, from the back with screws and with M8 nuts inserted into the cover caps
Liefereinheit	10 Sets	Pack Quantity	10 sets
Extras	weitere Farben auf Anfrage	Specials	Other colors on request
Hinweis	* Bitte beachten: 1 Set = 2 Stück	Tip	* Please note: 1 set = 2 pieces

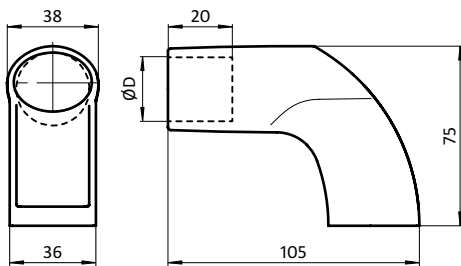

Endstücke für Systemgriff
End Pieces for System Handle

	ØD [mm]	für Schraube for Screw	Gewicht [g] Weight [g]	Teil-Nr. Part #
Set Endstücke D30* Set of end pieces D30*	30.1	M8	49.5	092013
Set Endstücke D28* Set of end pieces D28*	28.1	M8	52.5	092321

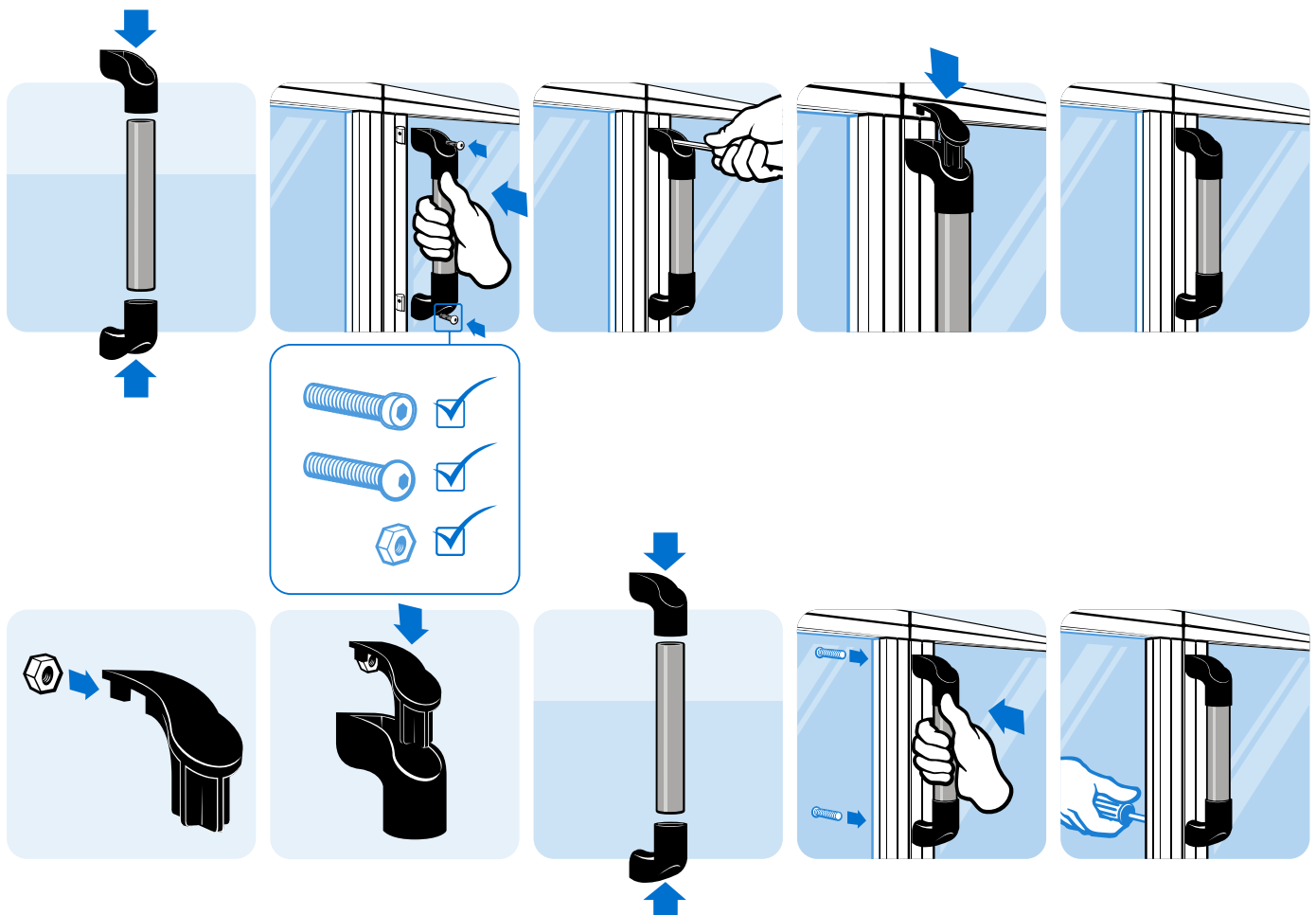

GRIFSTANGE FÜR SYSTEMGRIFF

TUBES FOR SYSTEM HANDLE

Ausführung	zur Kombination mit den Endstücken	Model	For combining with the end pieces
Beschreibung	zur Montage auf Türen, Klappen und Aluminiumprofilen	Description	To mount on doors, flaps and aluminum profiles
Befestigung	mit den Endstücken für Systemgriff	Fastening	End pieces for system handle
Liefereinheit	10 Stück	Pack Quantity	10 pieces
Extras	weitere Oberflächen, weitere Farben auf Anfrage	Specials	Other surfaces, other colors on request
Hinweis	* zum selbst Ablängen	Tip	* for cut to length

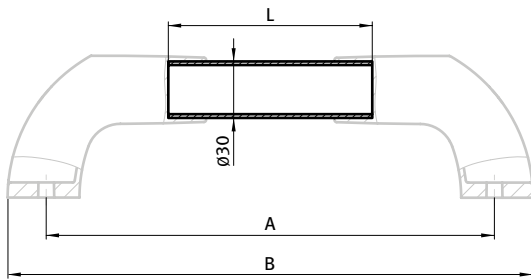

Griffstange für Systemgriff <i>Tubes for System Handle</i>	A [mm]	B [mm]	L [mm]	Gewicht [g] <i>Weight [g]</i>	Teil-Nr. <i>Part #</i>
Kohlefaser, klarlackiert <i>Carbon fiber, glossy finish</i>	200.0	240.8	70.0	16.0	092013C200
	300.0	340.8	170.0	39.0	092013C300
	400.0	440.8	270.0	62.0	092013C400
	500.0	540.8	370.0	85.0	092013C500
			*2000.0	364.0	092013C.2000
Aluminium, eloxiert <i>Aluminum, anodized</i>	200.0	240.8	70.0	17.0	092013A200
	300.0	340.8	170.0	42.0	092013A300
	400.0	440.8	270.0	67.0	092013A400
	500.0	540.8	370.0	91.0	092013A500
			*2000.0	490.0	092013A.2000
Edelstahl <i>Stainless steel</i>	200.0	240.8	70.0	51.0	092013E200
	300.0	340.8	170.0	124.0	092013E300
	400.0	440.8	270.0	197.0	092013E400
	500.0	540.8	370.0	270.0	092013E500
			*2000.0	1400.0	092013E.2000
Stahl, kunststoffummantelt <i>Steel, plastic covered</i>	200.0	240.8	70.0	53.0	092013S200
	300.0	340.8	170.0	120.0	092013S300
	400.0	440.8	270.0	203.0	092013S400
	500.0	540.8	370.0	279.0	092013S500
			*2000.0	1500.0	092013S.2000

5

GRIFFLEISTE

STRIP HANDLE

Ausführung	Aluminium, eloxiert	Model	Aluminum, anodized
Beschreibung	zur Montage auf Türen, Klappen und Aluminium-profile	Description	To mount on doors, flaps and aluminum profiles
Material	Griffleiste: Aluminium Abdeckkappen: Kunststoff PA, glasfaserverstärkt	Material	Strip handle: Aluminum Cover caps: Plastic PA, glass fiber reinforced
Befestigung	vorderseitig mit aufgebohrtem Nutboden der Griffleiste, rückseitig mit Nutensteinen in der Griffleiste	Fastening	From the front with holes drilled into the slot base, From the back with T-slot nuts in the strip handle
Set	1 Griffleiste in Länge L [mm], 1 Set Abdeckkappen = 2 Stück Abdeckkappen	Set	1 strip handle in length L [mm], 1 set cover caps = 2 pieces cover caps
Liefereinheit	10 Stück	Pack Quantity	10 pieces
Extras	verschiedene Längen auf Anfrage	Specials	Different lengths on request
Hinweis	* Bitte beachten: Sie bestellen in Meter! ** Bitte beachten: 1 Set = 2 Stück	Tip	* Please note: You are ordering in meters! ** Please note: 1 set = 2 pieces



Griffleiste Strip Handle	L [mm]	N	Gewicht [g] Weight [g]	Teil-Nr. Part #
Griffleiste* Strip Handle*	1500.0	5	1152.0	092024
Set Abdeckkappen** Set cover caps**			2.9	092021
Griffleiste 80 (Set) Strip handle 80 (set)	80.0	5	67.0	092022
Griffleiste 160 (Set) Strip handle 160 (set)	160.0	5	127.0	092023



FALLENVERSCHLUSS

SLAM LATCH

Ausführung	Zinkdruckguss	Model	Zinc die-cast
Beschreibung	zum leichten und sicheren Verschließen von Türen und Klappen	Description	To securely close doors and flaps
Material	Zinkdruckguss	Material	Zinc die-cast
Befestigung	rückseitig mit Schrauben M6	Fastening	From the back, using M6 screws
Liefereinheit	1 Stück	Pack Quantity	1 piece
Hinweis	* gleich: identische Schlüssel für alle Schlösser verschieden: jeder Fallenverschluß hat einen eigenen Schlüssel	Tip	* Universal: one key fits all slam latches Unique: each slam latch has a different key



Fallenverschluss <i>Slam Latch</i>	Schloss <i>Lock</i>	Gewicht [g] <i>Weight [g]</i>	Teil-Nr. <i>Part #</i>
	gleich* <i>Universal*</i>	560.0	0957101
	verschieden* <i>Unique*</i>	560.0	0957201
	ohne <i>Without</i>	560.0	0957301

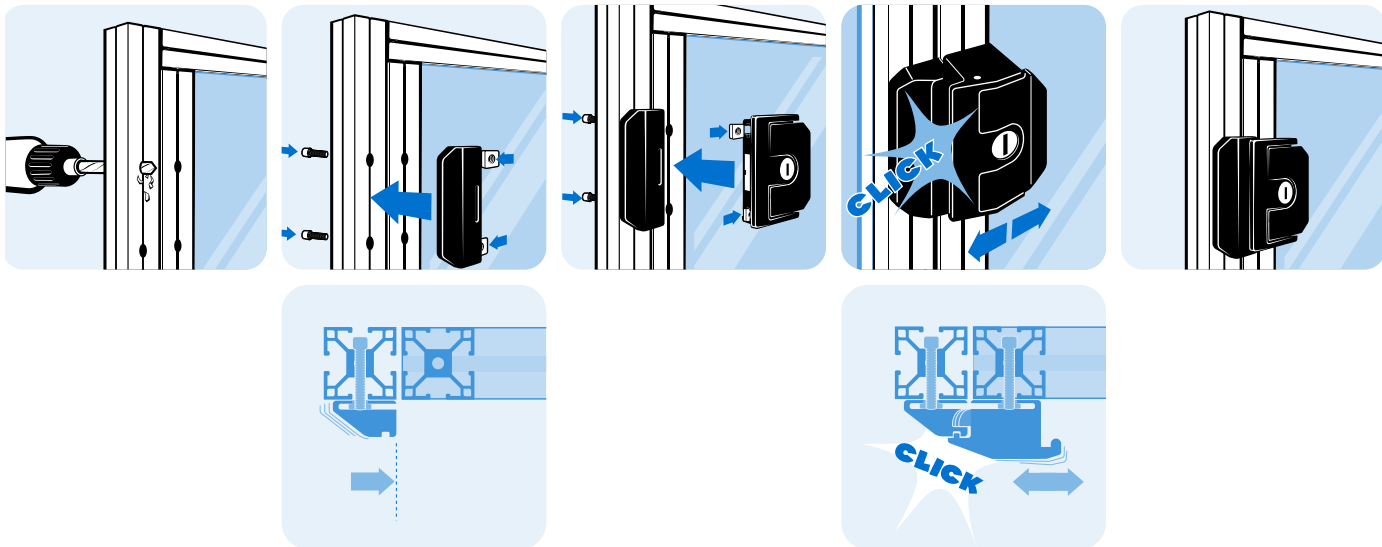

5

FALLENVERSCHLÜSSE

- modernes, symmetrisches FATH-Design
- bestens geeignet für die Montage auf Aluprofilen
- einfache, flexible Montage ohne mechanischen Aufwand
- abschließbar
- robustes Aluminiumgehäuse für raue Umgebungsbedingungen

SLAM LATCHES

- *Modern, symmetrical FATH design*
- *Ideal for assembly on aluminum profiles*
- *Simple and flexible mounting without mechanical effort*
- *Lockable*
- *Sturdy aluminum housing for harsh environments*



Alles im Griff - die Fallenverschlüsse von FATH

Die **FATH** Fallenverschlüsse sind funktionale Türgriffe für die Absicherung von trennenden Schutzeinrichtungen wie Türen und Klappen bei Maschinen und Anlagen.

Das kompakte und symmetrische Design ermöglicht eine einfache Montage an Profilen und erlaubt den Einsatz sowohl an links als auch an rechts angeschlagenen Türen. Das industrietaugliche Metallgehäuse verfügt über einen stabilen Türanschlag und ist optimal für die Verwendung in rauer Umgebung.



Alle Fallenverschlüsse im FATH-Design können von vorne montiert werden, insbesondere auch auf Aluminium-Profilen mithilfe von Nutensteinen oder Hammermuttern. Die beigefügten Abdeckkappen lassen sich im geschlossenen Zustand nicht entfernen und verhindern dadurch die unerwünschte Demontage des Fallenverschlusses.

Für Spaltabstand bis 5 mm passend zu den meisten Scharnieren.

Ausführungen:

- Aluminium-Druckguss, schwarz oder alufarbig pulverbeschichtet
- mit und ohne Schloss, es stehen verschiedene Schlösser zur Auswahl (gleich, verschieden, Doppelbart, Vierkant)
- Fallenverschluss Compact als Twin-Ausführung für Doppeltüren mit Mittelposten
- Fallenverschluss PRO als PROe mit elektronischer Sicherheitsfunktion

Everything Under Control – Slam Latches by FATH

FATH Slam Latches are multifunctional door handles for protecting safety guards such as doors and flaps on machines and installations.

The compact and symmetrical design permits simple mounting on profile rails and allows use on doors hinged on the left and right. The metal housing suitable for industrial use features a sturdy door stop and is ideal for use in a harsh environment.

All Slam Latches designed by FATH can be mounted from the front side, in particular on aluminum profiles, using T-slot nuts or hammer nuts. The cover caps attached are safe against removal as long as the latch is locked, thus preventing a unwanted disassembly of the slam latch.

Gap clearance up to 5 mm, consistent with most hinges.

Versions:

- Die-cast aluminum, black or alu color powder coated
- With or without lock, different lock types are available (unique, universal, double-bit lock, square lock)
- Slam Latch Compact as Twin version for double winged-doors with single post
- Slam Latch PRO as PROe with electronic safety feature

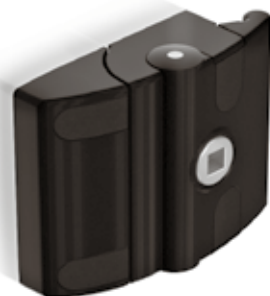



FALLENVERSCHLUSS COMPACT

SLAM LATCH COMPACT

Ausführung	Aluminiumdruckguss	Model	Die-cast aluminum
Beschreibung	zum leichten und sicheren Verschließen von Türen und Klappen, Montage ohne mechanische Bearbeitung; im geschlossenen Zustand gegen Demontage gesichert	Description	For an easy and secure latching and locking of doors and flaps, no mechanical preparation needed for the assembly; safe against disassembling in the locked position
Material	Aluminiumdruckguss	Material	Die-cast aluminum
Befestigung	vorderseitig mit Zylinder- oder Linsenkopfschrauben M6	Fastening	From the front, using M6 socket head or pan head screws
Liefereinheit	1 Stück	Pack Quantity	1 piece
Hinweis	* gleich: identische Schlüssel für alle Schlösser verschieden: jeder Fallenverschluß hat einen eigenen Schlüssel; ** inklusive Doppelbartschlüssel passender Notöffner für Fallenverschluss siehe Seite 546	Tip	* Universal: one key fits all slam latches Unique: each slam latch has a different key; ** With double-bitted key Compatible emergency opener for slam latch see page 546

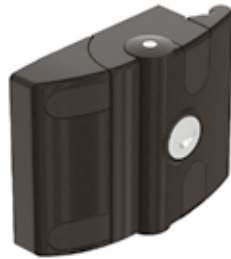
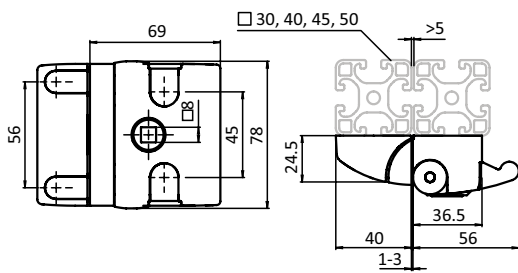

Fallenverschluss <i>Slam Latch</i>	Schloss <i>Lock</i>	Gewicht [g] <i>Weight [g]</i>	Teil-Nr. <i>Part #</i>
schwarz pulverbeschichtet <i>Black powder coated</i>	gleich* <i>Universal*</i>	235.5	0957408
	verschieden* <i>Unique*</i>	235.5	0957411
	ohne <i>Without</i>	204.0	0957410
	Vierkantschloss <i>Square lock</i>	220.0	0957431
	Doppelbartschloss** <i>Double-bit lock**</i>	220.0	0957432
alufarbig pulverbeschichtet <i>Aluminum color powder coated</i>	gleich* <i>Universal*</i>	235.5	0957408S01
	verschieden* <i>Unique*</i>	235.5	0957411S01
	ohne <i>Without</i>	204.0	0957410S01

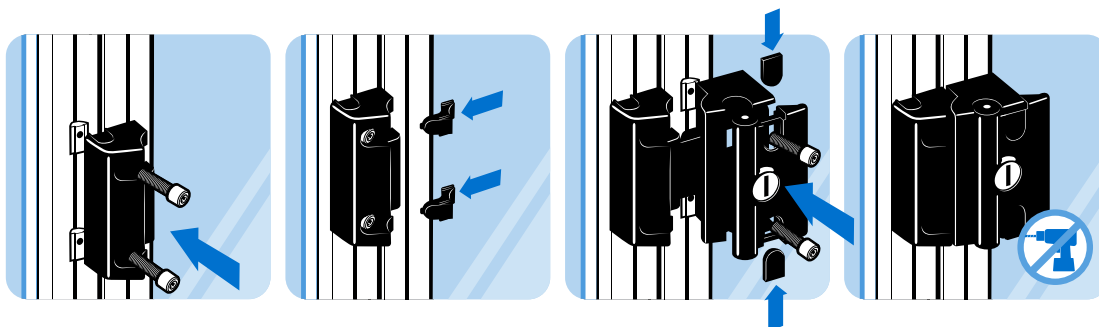

TWIN-FALLENVERSCHLUSS COMPACT

TWIN SLAM LATCH COMPACT

<p>Ausführung Aluminiumdruckguss</p> <p>Beschreibung zum leichten und sicheren Verschließen von Türen und Klappen, Montage ohne mechanische Bearbeitung; im geschlossenen Zustand gegen Demontage gesichert; ermöglicht selektiven Zugang unter Verwendung nur eines Pfostens; mit separaten Nutfixierungen für Nut 8 und Nut 10</p> <p>Material Aluminiumdruckguss</p> <p>Befestigung vorderseitig mit Zylinder- oder Linsenkopfschrauben M6</p> <p>Liefereinheit 1 Stück</p> <p>Extras weitere Schlosskombinationen auf Anfrage</p> <p>Hinweis * gleich: identische Schlüssel für alle Schlösser; verschieden: jeder Fallenverschluß hat einen eigenen Schlüssel passender Notöffner für Fallenverschluss siehe Seite 546</p>	<p>Model Die-cast aluminum</p> <p>Description For an easy and secure latching and locking of doors and flaps, no mechanical preparation needed for the assembly; safe against disassembling in the locked position; provides selective access by use of a single post; with separate locating pins for slot 8 and slot 10</p> <p>Material Die-cast aluminum</p> <p>Fastening From the front, using M6 socket head or pan head screws</p> <p>Pack Quantity 1 piece</p> <p>Specials Other combinations of slam latches on request</p> <p>Tip * Universal: one key fits all slam latches; Unique: each slam latch has a different key Compatible emergency opener for slam latch see page 546.</p>
--	--

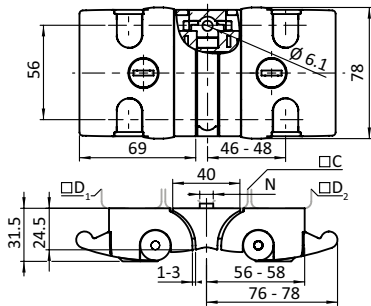

Fallenverschluss <i>Slam Latch</i>	C (D1/D2) [mm]	N	Schloss Lock	Gewicht [g] Weight [g]	Teil-Nr. Part #
40 (30, 40, 45); 45 (30, 40, 45); 50 (30, 40, 45); 60 (30)	— / 8 / 10	gleich* <i>Universal*</i>	448.0	0957420S01	
40 (30, 40, 45) 45 (30, 40, 45) 50 (30, 40, 45) 60 (30)	— / 8 / 10	verschieden* <i>Unique*</i>	448.0	0957420S02	

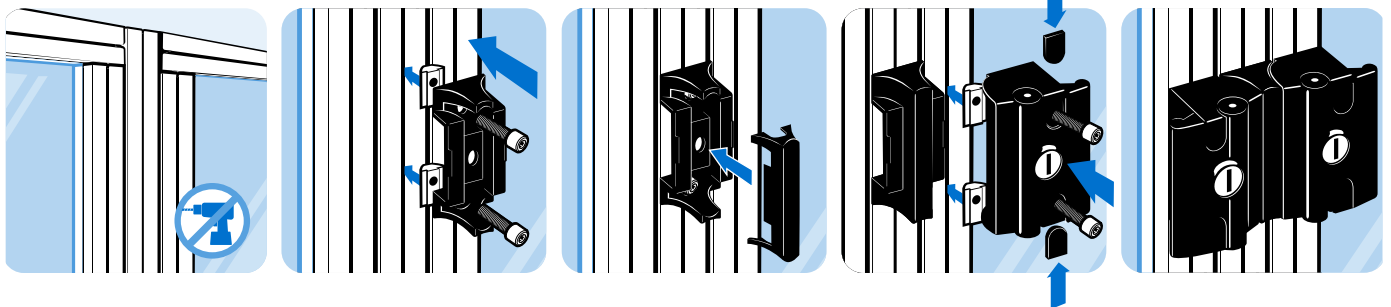



SCHIEBETÜRVERSCHLUSS COMPACT

SLIDE DOOR LATCH COMPACT

<p>Ausführung Aluminiumdruckguss</p> <p>Beschreibung zum leichten und sicheren Verschließen von Schiebetüren, Montage ohne mechanische Bearbeitung; im geschlossenen Zustand gegen Demontage gesichert</p> <p>Material Aluminiumdruckguss</p> <p>Oberfläche schwarz pulverbeschichtet</p> <p>Befestigung vorderseitig mit Zylinder- oder Linsenkopfschrauben M6</p> <p>Liefereinheit 1 Stück</p> <p>Hinweis * gleich: identische Schlüssel für alle Schlösser verschieden: jeder Fallenverschluß hat einen eigenen Schlüssel passender Notöffner für Fallenverschluss mit Sicherheitsraste siehe Seite 546, zusätzlich innen montierter Handgriff empfohlen</p>	<p>Model Die-cast aluminum</p> <p>Description For an easy and secure latching and locking of sliding doors and flaps, no mechanical preparation needed for the assembly; safe against disassembling in the locked position</p> <p>Material Die-cast aluminum</p> <p>Surface Black powder coated</p> <p>Fastening From the front, using M6 socket head or pan head screws</p> <p>Pack Quantity 1 piece</p> <p>Tip * Universal: one key fits all slam latches Unique: each slam latch has a different key Compatible emergency opener for slam latch with safety catch see page 546, additional inside mounted handle recommended</p>
--	--

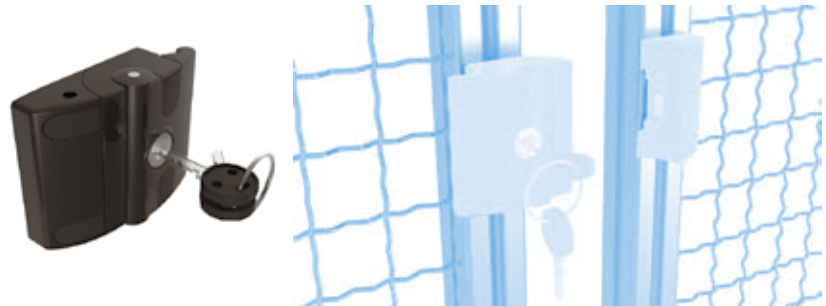
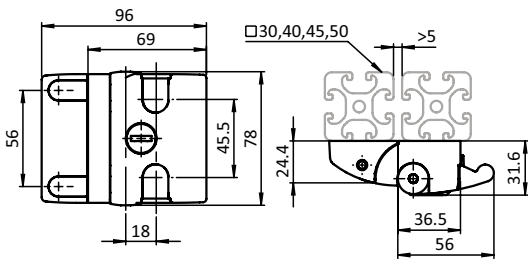

Schiebetürverschluss
Slide Door Latch

Schloss <i>Lock</i>	Gewicht [g] <i>Weight [g]</i>	Teil-Nr. <i>Part #</i>
gleich* <i>Universal*</i>	246.0	0957415
verschieden* <i>Unique*</i>	246.0	0957416
ohne <i>Without</i>	216.0	0957417

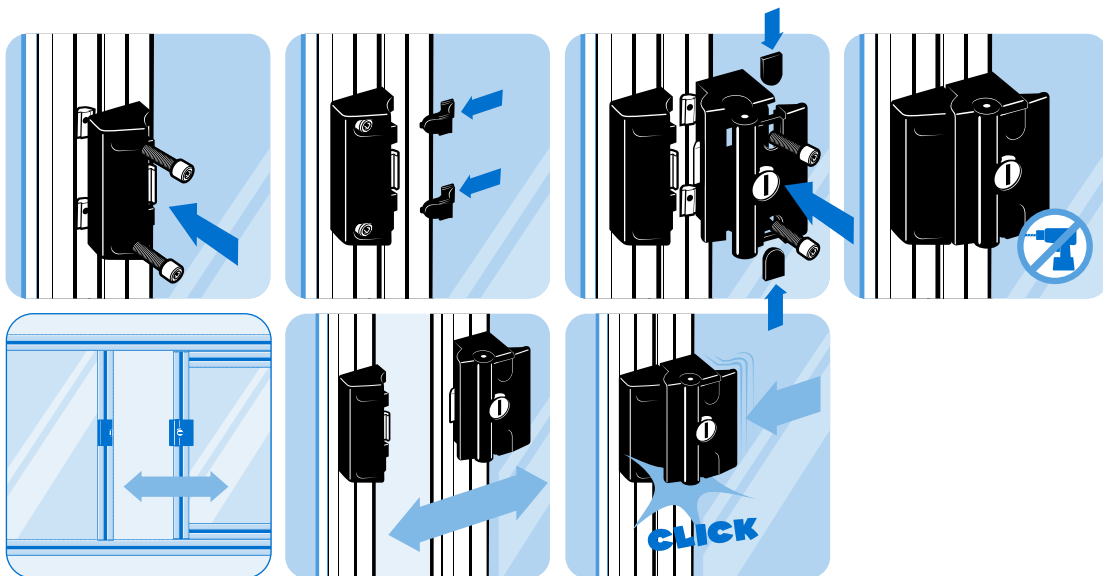

FALLENVERSCHLUSS PRO

SLAM LATCH PRO

<p>Ausführung Aluminiumdruckguss</p> <p>Beschreibung zum leichten und sicheren Verschließen von Türen und Klappen, Montage ohne mechanische Bearbeitung; im geschlossenen Zustand gegen Demontage gesichert</p> <p>Material Aluminiumdruckguss</p> <p>Befestigung vorderseitig mit Zylinder- oder Linsenkopfschrauben M7</p> <p>Liefereinheit 1 Stück</p> <p>Hinweis * gleich: identische Schlüssel für alle Schlösser verschieden: jeder Fallenverschluß hat einen eigenen Schlüssel passender Notöffner für Fallenverschluss siehe Seite 546</p>	<p>Model Die-cast aluminum</p> <p>Description For an easy and secure latching and locking of doors and flaps, no mechanical preparation needed for the assembly; safe against disassembling in the locked position</p> <p>Material Die-cast aluminum</p> <p>Fastening From the front, using M6 socket head or pan head screws</p> <p>Pack Quantity 1 piece</p> <p>Tip * Universal: one key fits all slam latches Unique: each slam latch has a different key Compatible emergency opener for slam latch see page 546</p>
--	--

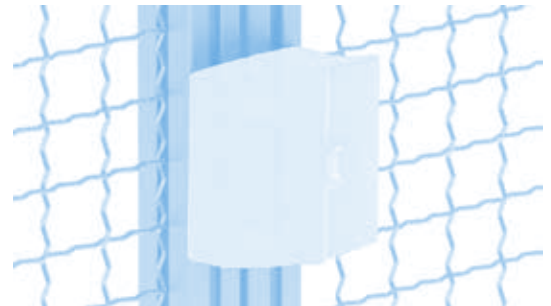
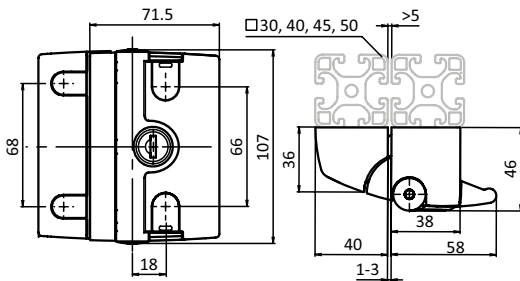

Fallenverschluss <i>Slam Latch</i>	Schloss <i>Lock</i>	Gewicht [g] <i>Weight [g]</i>	Teil-Nr. <i>Part #</i>
	gleich* <i>Universal*</i>	370.0	0957404
	verschieden* <i>Unique*</i>	370.0	0957405
	ohne <i>Without</i>	340.0	0957406

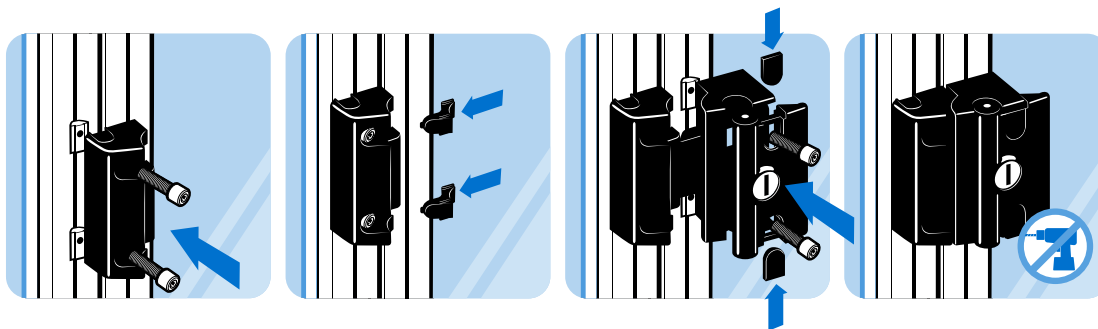

FALLENVERSCHLUSS PROe

Alles im Griff: Der Fallenverschluss FATH PROe mit Sicherheitsfunktion

- Türgriff mit integrierter Sicherheitsfunktion
- Absicherung von Schutztüren und -klappen bis Kat. 4 / PLe
- modernes, symmetrisches Design
- bestens geeignet für die Montage auf Aluprofilen

FATH PROe ist ein multifunktionaler Türgriff für die Absicherung und Überwachung von trennenden Schutzeinrichtungen wie Türen und Klappen bei Maschinen und Anlagen. Er besteht aus einem Griff- und einem Verriegelungsmodul, ausgestattet mit der bewährten transpondercodierten Sicherheitstechnik CES von EUCHNER. Der Einsatz der Transpondertechnologie gewährleistet ein Höchstmaß an Sicherheit nach EN ISO 13849-1 (Kat. 4 / PLe) und bedingt höchste Manipulationssicherheit.

Durch die eingebaute CES AR-Auswerteelektronik können bis zu 20 FATH PROe-Einheiten in Reihe geschaltet werden. Für die Statusanzeige verfügt das FATH PROe über zwei gut sichtbare LEDs, die eine schnelle Diagnose gewährleisten. Das kompakte und symmetrische Design ermöglicht eine einfache Montage an Profilen und erlaubt den Einsatz sowohl an links als auch rechts angeschlagenen Türen. Das industrietaugliche Metallgehäuse verfügt über einen stabilen Türanschlag und ist optimal für die Verwendung in rauer Umgebung.

Der Anschluss erfolgt bequem über einen M12-Steckverbinder. Je nach Leitungsführung kann dessen Position um 180 Grad gedreht werden. Als zusätzlichen Schutz vor ungewolltem Öffnen ist FATH PROe mit einem Schloss ausgestattet.

Ihre Vorteile

- Einfache und flexible Montage ohne mechanischen Aufwand
- Abschließbar zum Schutz vor ungewolltem Maschinenstillstand
- Robustes Metallgehäuse für raue Umgebungsbedingungen
- Höchste Sicherheit (Kat. 4 / PLe) dank integrierter transpondercodierter Sicherheitstechnik

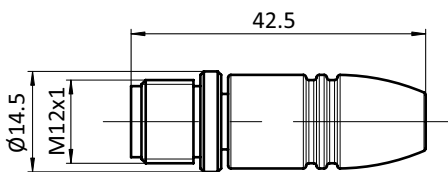

SLAM LATCH PROe



Everything under Control: Slam Latch FATH PROe with Safety Feature

- Door handle with integrated safety function
- Protection of safety doors and flaps up to Cat. 4 / PLe
- Modern, symmetrical design
- Ideal for assembly on aluminum profiles

FATH PROe is a multi-functional door handle for protecting and monitoring safety guards such as doors and flaps on machines and installations.

It consists of a handle and an interlocking module equipped with the proven transponder-coded safety technology CES by EUCHNER. The use of transponder technology ensures maximum safety according to EN ISO 13849-1 (Cat. 4 / PLe) and provides the best possible protection against tampering.

With the installed CES AR evaluation electronics, up to 20 FATH PROe systems can be connected in series. FATH PROe is equipped with two easily visible LEDs for status indication, permitting rapid diagnosis. The compact and symmetrical design permits simple mounting on profile rails and allows use on doors hinged on the left and right. The metal housing suitable for industrial use features a sturdy door stop and is ideal for use in a harsh environment.

The device is conveniently connected via an M12 plug connector. Depending on the cable routing, the position can be rotated by 180 degrees. As additional protection against unintentional opening, FATH PROe is equipped with a lock.

Your advantages

- Simple and flexible mounting without mechanical effort
- Lockable to protect against unintentional machine stoppage
- Robust metal housing for harsh environments
- Maximum safety (Cat. 4 / PLe) thanks to integrated transponder-coded safety technology

Passendes Verbindungsmaterial <i>Compatible Connection Material</i>	Anschluss <i>Connection</i>	Ausführung <i>Version</i>	Teil-Nr. <i>Part #</i>
Kurzschlussstecker <i>Short-circuit plug</i>	M12	4-polig, Stift <i>4 pole, Pin</i>	0957WS
Y-Verteiler mit Anschlussleitung <i>Y-distributor with connection cable</i>	M12	1 x 8-polig, 2 x 5-polig <i>1 x 8 pole, 2 x 5 pole</i>	0957WY02
Y-Verteiler <i>Y-distributor</i>	M12	1 x 8-polig, 2 x 5-polig <i>1 x 8 pole, 2 x 5 pole</i>	0957WY
Anschlussleitung PVC, offenes Kabelende <i>Connection cable PVC, open cable end</i>	M12	8-polig <i>8 pole, 5 m</i>	0957WL5
	M12	8 pole <i>8-polig, 10 m</i>	0957WL10
	M12	8 pole <i>8-polig, 20 m</i>	0957WL20

FALLENVERSCHLUSS PROe

SLAM LATCH PROe

<p>Ausführung Aluminiumdruckguss</p> <p>Beschreibung zum leichten und sicheren Verschließen von Türen und Klappen, Montage ohne mechanische Bearbeitung; im geschlossenen Zustand gegen Demontage gesichert; Stecker M12 - achtpolig, für Tür rechts oder links angeschlagen, Steckerausgang unten oder oben; Systemspannung 24 V; UL-zertifiziert, geprüft nach BG; Sicherheitsklasse Kategorie 4, PLe</p> <p>Material Aluminiumdruckguss</p> <p>Befestigung vorderseitig mit Zylinder- oder Linsenkopfschrauben M6</p> <p>Liefereinheit 1 Stück</p> <p>Hinweis * gleich: identische Schlüssel für alle Schlösser passender Notöffner für Fallenverschluss siehe Seite 546</p>	<p>Model Die-cast aluminum</p> <p>Description For an easy and secure latching and locking of doors and flaps, no mechanical preparation needed for the assembly; safe against disassembling in the locked position; plug M12, 8-pin, for left or right-hand door, connector position at the bottom or at the top; system voltage 24 V; UL-certified, tested according to BG; safety class category 4, PLe</p> <p>Material Die-cast aluminum</p> <p>Fastening From the front, using M6 socket head or pan head screws</p> <p>Pack Quantity 1 piece</p> <p>Tip * Universal: one key fits all slam latches Compatible emergency opener for slam latch see page 546</p>
---	---

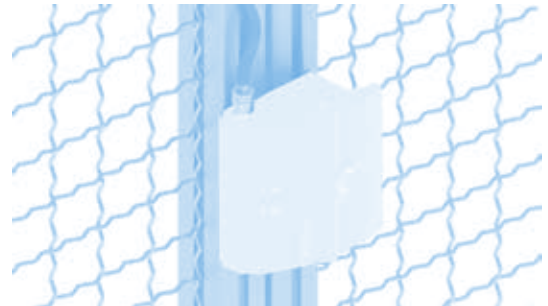
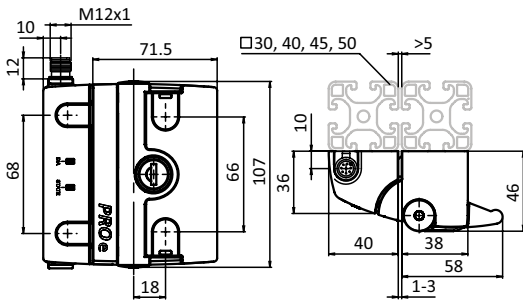

Fallenverschluss PROe Slam Latch PROe	Unicode	Schloss Lock	Gewicht [g] Weight [g]	Teil-Nr. Part #
	Unicode	gleich* Universal*	380.0	095740107xxARA-A4SR

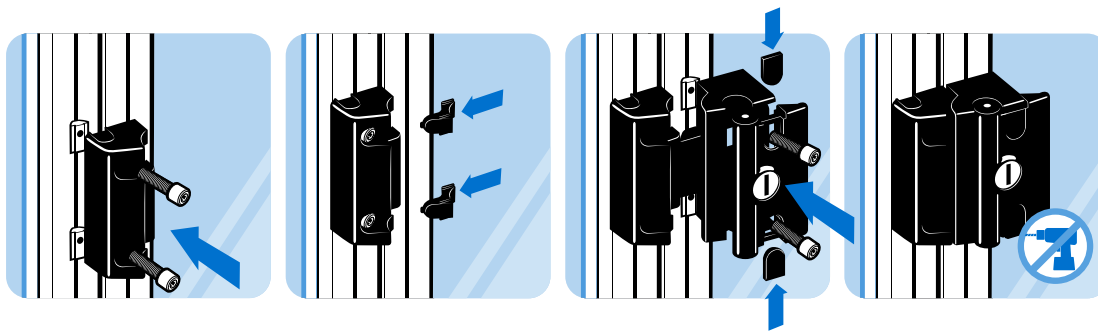



NOTÖFFNER FÜR FALLENVERSCHLUSS

EMERGENCY OPENER FOR SLAM LATCH

Ausführung	Kunststoff PA	Model	Plastic PA
Beschreibung	zur rückseitigen Notentriegelung von Fallenverschluss PROe, PRO und Compact; mit oder ohne Sicherheitsraste	Description	Inside emergency release for slam latches PROe, PRO and Compact; with or without safety catch
Material	Grundkörper: Kunststoff PA 6, glasfaserverstärkt Druckknopf: Kunststoff PA 6, glasfaserverstärkt Entsperrriegel: Stahl	Material	Base part: Plastic PA, glass fiber reinforced Push button: Plastic PA, glass fiber reinforced Unlocking plate: Steel
Farbe	Grundkörper: schwarz Druckknopf: rot ≈RAL 3020	Color	Base part: Black Push button: Red ≈RAL 3020
Befestigung	vorderseitig mit zwei Zylinderschrauben DIN 912 M6 × 20	Fastening	From the front, using two socket head screws DIN 912 M6 × 20
Liefereinheit	1 Stück	Pack Quantity	1 piece

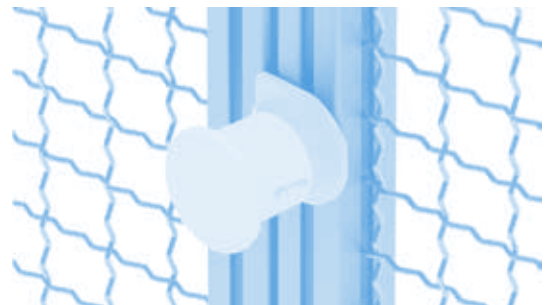
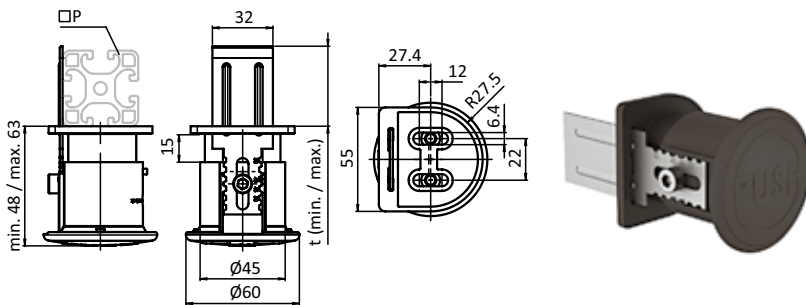

Notöffner für Fallenverschluss Emergency Opener for Slam Latch	P [mm]	t (max.) [mm]	t (min.) [mm]	Gewicht [g] Weight [g]	Teil-Nr. Part #
mit Sicherheitsraste <i>With safety catch</i>	30-50	50	30	110.8	0957409
	60-80	80	60	115.4	0957409S03
ohne Sicherheitsraste <i>Without safety catch</i>	30-50	50	30	110.8	0957409S02

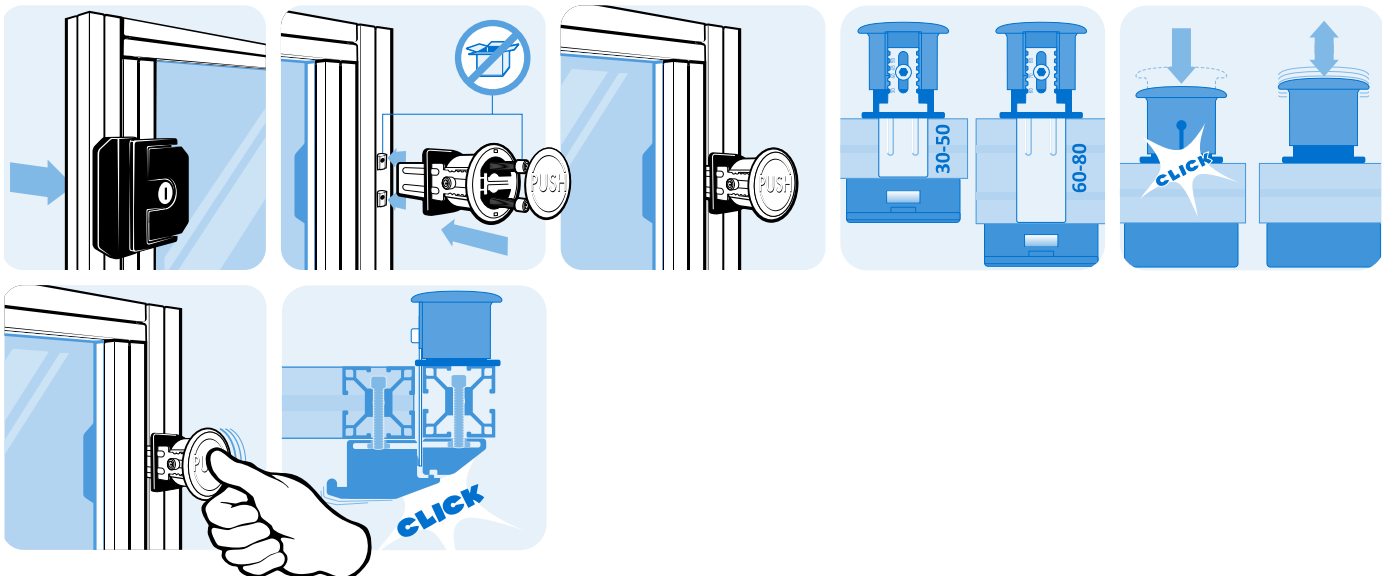

5



TÜRSCHLOSS

DOOR LOCK

<p>Ausführung Aluminiumdruckguss</p> <p>Beschreibung zum leichten und sicheren Verschließen von Schwenk- und Schiebetüren, Montage ohne mechanische Bearbeitung</p> <p>Material Gehäuse: Aluminiumdruckguss Arretierungskreuz: Aluminiumdruckguss Griff: Zinkdruckguss Befestigungsmaterial: Stahl</p> <p>Farbe Gehäuse: alufarbig Arretierungskreuz: schwarz Griff: schwarz</p> <p>Set 1 Türschloss, 2 Schrauben DIN 912 - M6 × 30, 1 Scheibe 6-FSt, 1 Anker - M6, 1 Mutter DIN 934 - M6, 1 Scheibe DIN 9021 Form A - 6.4, 3 Hammermuttern - Nut 8 - M6, 3 Hammermuttern - Nut 10 - M6</p> <p>Liefereinheit 1 Stück</p> <p>Hinweis * gleich: identische Schlüssel für alle Schlösser verschieden: jedes Türschloss hat einen eigenen Schlüssel ** inklusive Doppelbartschlüssel</p>	<p>Model Die-cast aluminum</p> <p>Description For an easy and secure latching and locking of swing and sliding doors, no mechanical preparation needed for the assembly</p> <p>Material Housing: Die-cast aluminum Cross: Die-cast aluminum Handle: Zinc die-cast Fastening material: Steel</p> <p>Color Housing: Alu color Cross: Lack Handle: Black</p> <p>Set 1 door lock, 2 screws DIN 912 - M6 × 30, 1 washer 6-FSt, 1 anchor - M6, 1 nut DIN 934 - M6, 1 washer DIN 9021 form A - 6.4, 3 hammer nut - slot 8 - M6, 3 hammer nut - slot 10 - M6</p> <p>Pack Quantity 1 piece</p> <p>Tip * Universal: one key fits all slam latches Unique: each door lock has a different key ** With double-bitted key</p>
---	---

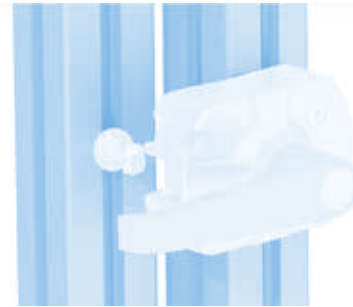
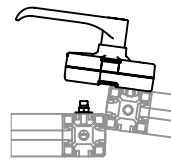
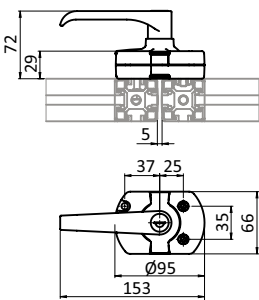

Türschloss (Set) Door Lock (Set)	Schloss Lock	Gewicht [g] Weight [g]	Teil-Nr. Part #
	verschieden * <i>Unique</i> *	407.0	0957505
	gleich * <i>Universal</i> *	407.0	0957504
	Doppelbartschloss ** <i>Double-bit lock</i> **	407.0	0957506

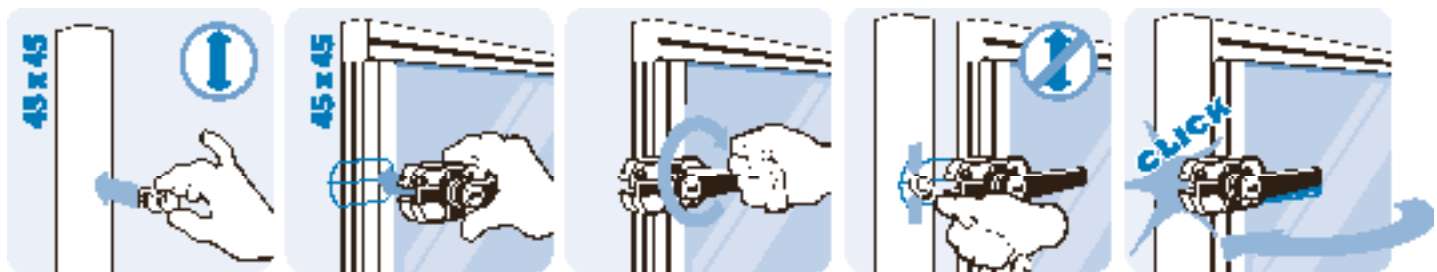



MAGNETVERSCHLUSS 20

MAGNETIC CATCH 20

Ausführung	Kunststoff PA	Model	Plastic PA
Beschreibung	Schnellverschluss für Türen, an die Stärke des Flächenelementes anpassbar	Description	A quick locking device for doors, adaptable to the thickness of the panel units
Material	Magnetverschluss: Kunststoff PA, glasfaserverstärkt Montageset: Stahl Befestigungswinkel: Aluminium	Material	Magnetic catch: Plastic PA, glass fiber reinforced Assembly set: Steel Angle bracket: Aluminum
Farbe	Magnetverschluss: schwarz	Color	Magnetic catch: Black
Befestigung	mit Schrauben M4	Fastening	Using screws M4
Set	1 Magnetverschluss 20, 1 Halteplatte 14 × 41 × 2 mm, 2 Schrauben ISO 7380 - M4 × 10, 1 Befestigungswinkel	Set	1 magnetic catch 20, 1 counter plate 14 × 41 × 2 mm, 2 screws ISO 7380 - M4 × 10, 1 angle bracket
Liefereinheit	10 Stück	Pack Quantity	10 pieces
Extras	⚡ elektrostatisch entladend, weitere Größen, weitere Farben auf Anfrage	Specials	⚡ electrostatically discharging, other sizes, other colors on request

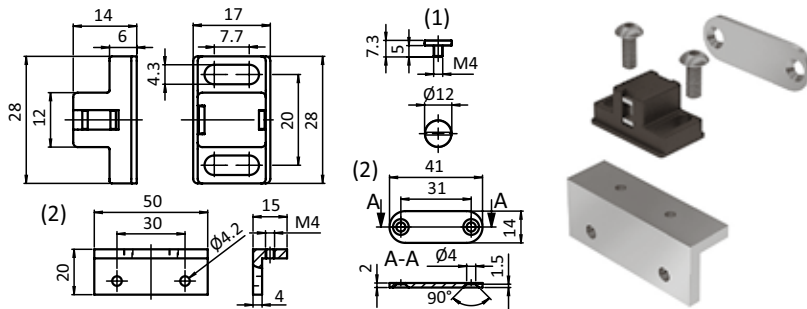

Magnetverschluss Magnetic Catch	Verschlusskraft Locking Force	Gewicht [g] Weight [g]	Teil-Nr. Part #
(1) inkl. Flachkopfschraube DIN 921 - M4 × 5, Stahl, verzinkt (1) With pan head screw DIN 921 - M4 × 5, zinc plated steel	ca. 5 N vorne / 3 N hinten Approx. 5 N front / 3 N back	9.0	093094
(2) Set	ca. 5 N vorne / 3 N hinten Approx. 5 N front / 3 N back	33.0	093046

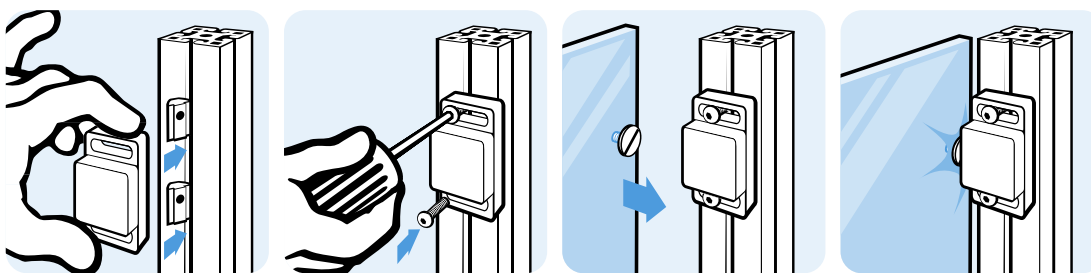

MAGNETVERSCHLUSS 30 (SET)

MAGNETIC CATCH 30 (SET)

Ausführung	Kunststoff PA	Model	Plastic PA
Beschreibung	Schnellverschluss für Türen, an die Stärke des Flächenelementes anpassbar	Description	A quick locking device for doors, adaptable to the thickness of the panel units
Material	Magnetverschluss: Kunststoff PA, glasfaserverstärkt Montageset: Stahl	Material	Magnetic catch: Plastic PA, glass fiber reinforced Assembly set: Steel
Farbe	Magnetverschluss: schwarz	Color	Magnetic catch: Black
Befestigung	Magnetverschluss: mit Schrauben M6 Halteplatte: mit Senkschrauben M4	Fastening	Magnetic catch: using M6 screws Counter plate: using M4 countersunk screws
Set	1 Magnetverschluss 30, 1 Flachkopfschraube DIN 921 - M5 × 6, 1 Halteplatte 14 × 41 × 2 mm	Set	1 magnetic catch 30, 1 flat head screw DIN 921 - M5 × 6, 1 counter plate 14 × 41 × 2 mm
Liefereinheit	10 Stück	Pack Quantity	10 pieces
Extras	⚡ elektrostatisch entladend, weitere Größen, weitere Farben auf Anfrage	Specials	⚡ electrostatically discharging, other sizes, other colors on request

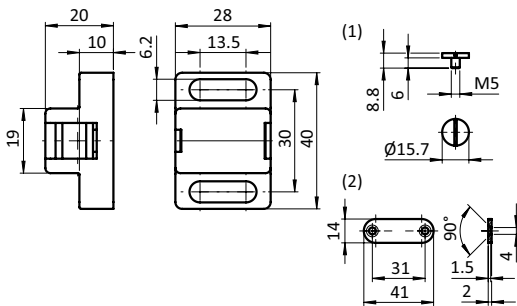

Magnetverschluss 30 (Set) Magnetic Catch 30 (Set)	Verschlusskraft Locking Force	Gewicht [g] Weight [g]	Teil-Nr. Part #
(1) inkl. Flachkopfschraube DIN 921 - M5 × 6, Stahl, verzinkt (1) incl. pan head screw DIN 921 - M5 × 6, steel, zinc-plated	ca. 20 N vorne / 10 N hinten Approx. 20 N front / 10 N back	39.0	093040
(2) Set (2) set	ca. 20 N vorne / 10 N hinten Approx. 20 N front / 10 N back	45.9	093044

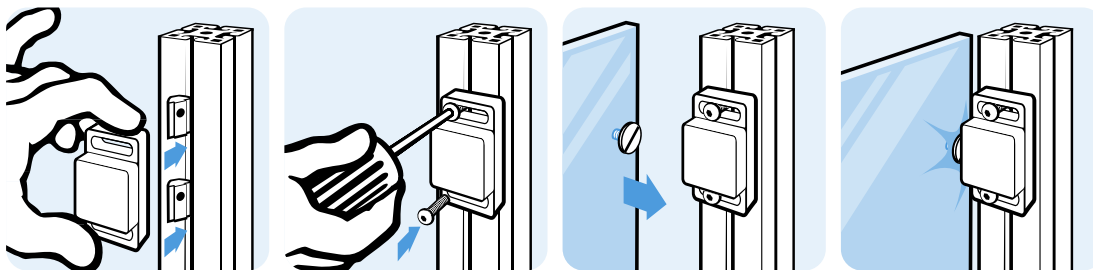

Griffe und Verschlüsse *Handles and Latches*

Fallenverschlüsse *Slam Latches*

Magnetverschlüsse *Magnetic Locks*



BEFESTIGUNGSWINKEL FÜR MAGNETVERSCHLUSS 30 ANGLE BRACKET FOR MAGNETIC CATCH 30

Ausführung	Stahl	Model	Steel
Beschreibung	zum flexiblen Positionieren des Magnetverschlusses 30	Description	To flexibly position the magnetic catch 30
Material	Stahl	Material	Steel
Liefereinheit	10 Stück	Pack Quantity	10 pieces
Extras	weitere Oberflächen, weitere Farben auf Anfrage	Specials	Other surfaces, other colors on request

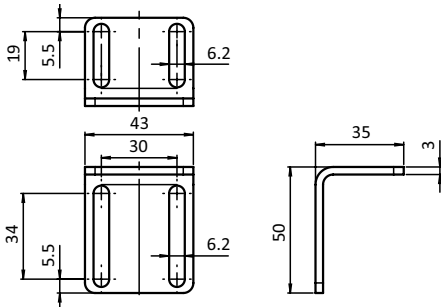

Befestigungswinkel für Kugelschnapper
Angle Bracket for Ball Catch

Gewicht [g]
Weight [g]

Teil-Nr.
Part #

62.0

093040W

Griffe und Verschlüsse *Handles and Latches*

Fallenverschlüsse *Slam Latches*

Magnetverschlüsse *Magnetic Locks*



MAGNET-VERSCHLUSSGRIFF COMPACT

MAGNETIC CATCH HANDLE COMPACT

Ausführung	Kunststoff PA	Model	Plastics PA
Beschreibung	Schnellverschluss für Türen; justierbar	Description	Quick fastener for doors; adjustable
Material	Verschlussgriff: Kunststoff PA, glasfaserverstärkt Dämpfer: TPE, ≈90 Shore A Magnet: Neodym Feder: Edelstahl Halteplatte: Stahl	Material	Catch handle: Plastic PA, glass fiber reinforced Buffer: TPE, ≈90 Shore A Magnet: Neodymium Spring: Stainless steel Counter plate: Steel
Farbe	Verschlussgriff: schwarz Dämpfer: schwarz	Color	Catch handle: Black Buffer: Black
Oberfläche	Feder: blank Halteplatte: verzinkt	Surface	Spring: Plain Counter plate: Zinc plated
Befestigung	Verschlussgriff: vorderseitig mit Zylinder- oder Linsenkopfschrauben M6 Halteplatte: vorderseitig mit Senkkopfschrauben M5	Fastening	Catch handle: From the front with using cylinder or button head screws M6 Counter plate: From the front with countersunk M5
Liefereinheit	10 Stück	Pack Quantity	10 pieces
Extras	weitere Farben auf Anfrage	Specials	Other colors on request

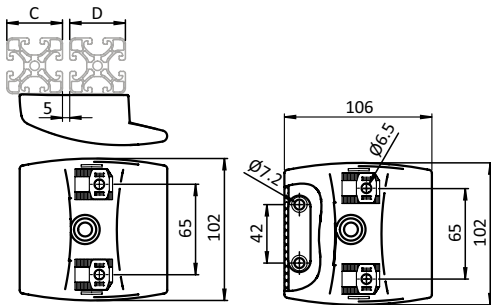

Magnet-Verschlussgriff Compact <i>Magnetic Catch Handle Compact</i>	C (D) [mm]	Verschlusskraft <i>Locking Force</i>	Gewicht [g] <i>Weight [g]</i>	Teil-Nr. <i>Part #</i>
	30 (38 - 1.5", 40, 45, 50, 60); 40 (38 - 1.5", 40, 45, 50, 60); 45 (38 - 1.5", 40, 45, 50); 50 (38 - 1.5", 40, 45, 50); 60 (30, 38 - 1.5", 40)	25 N	168.0	0957601



KUGELSCHNÄPPER

BALL CATCH

Ausführung	Kunststoff PA	Model	Plastic PA
Beschreibung	Schnellverschluss für Türen, an die Stärke des Flächenelementes anpassbar	Description	A quick locking device for doors, adaptable to the thickness of the panel units
Material	Kunststoff PA, glasfaserverstärkt	Material	Plastic PA, glass fiber reinforced
Farbe	schwarz	Color	Black
Befestigung	mit Schrauben	Fastening	Using screws
Liefereinheit	10 Stück	Pack Quantity	10 pieces
Extras	⚡ elektrostatisch entladend, weitere Größen, weitere Farben auf Anfrage	Specials	⚡ electrostatically discharging, other sizes, other colors on request

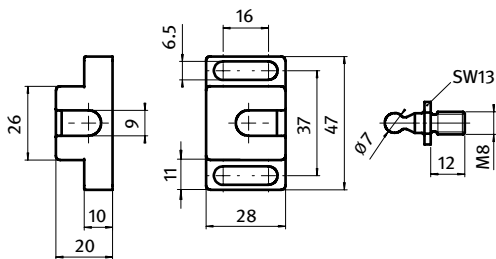

Kugelschnäpper Ball Catch	Halteschraube Counter Screw	Verschlusskraft Locking Force	Gewicht [g] Weight [g]	Teil-Nr. Part #
leicht <i>Light</i>	Stahl verzinkt <i>Zinc plated steel</i>	~ 40 N	45.0	093045
	Edelstahl <i>Stainless steel</i>	~ 40 N	45.0	093045S03
schwer <i>Strong</i>	Stahl verzinkt <i>Zinc plated steel</i>	~ 50 N	45.0	093043
	Edelstahl <i>Stainless steel</i>	~ 50 N	45.0	093043S02

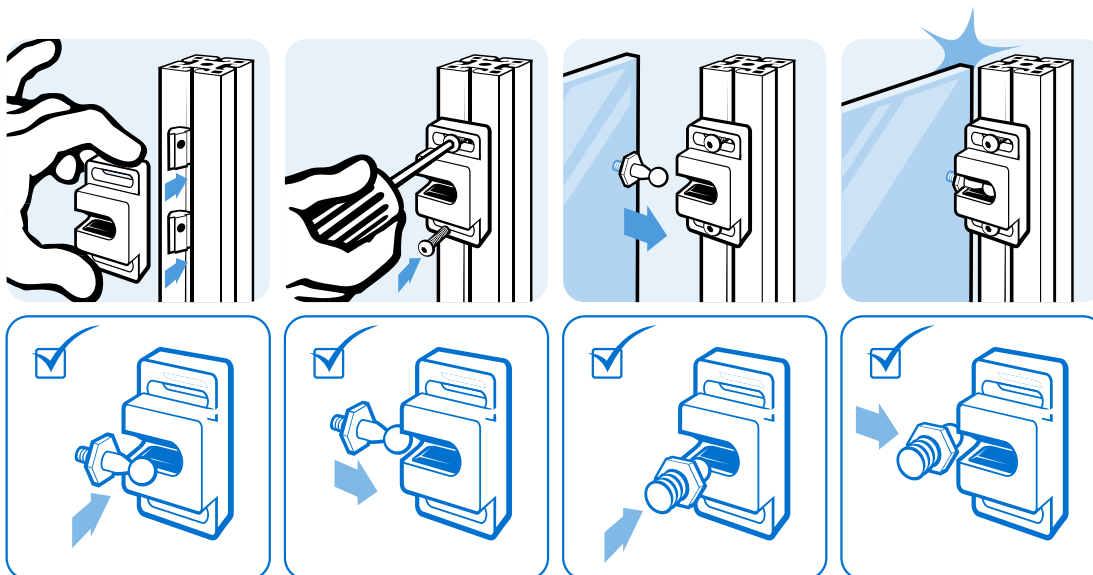

5

Griffe und Verschlüsse *Handles and Latches*

Fallenverschlüsse *Slam Latches*

Kugelschnäpper *Ball Catches*



ABSTANDSHALTER FÜR KUGELSCHNÄPPER

SPACER FOR BALL CATCH

Ausführung	Kunststoff PA	Model	Plastic PA
Beschreibung	zur Vergrößerung des Abstandes zum Aluminiumprofil	Description	To increase the distance to the aluminum profile
Material	Kunststoff PA, glasfaserverstärkt	Material	Plastic PA, glass fiber reinforced
Farbe	schwarz	Color	Black
Liefereinheit	10 Stück	Pack Quantity	10 pieces
Extras	☁ elektrostatisch entladend, weitere Größen, weitere Farben auf Anfrage	Specials	☁ electrostatically discharging, other sizes, other colors on request

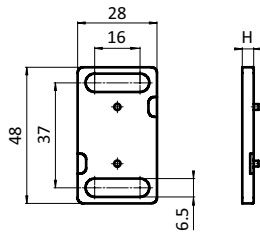

Abstandshalter für Kugelschnäpper
Spacer for Ball Catch

H
[mm]

Gewicht [g]
Weight [g]

Teil-Nr.
Part #

4.0

5.0

093043A4

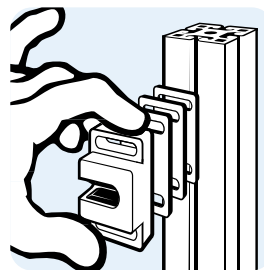

Griffe und Verschlüsse *Handles and Latches*

Fallenverschlüsse *Slam Latches*

Kugelschnäpper *Ball Catches*



BEFESTIGUNGSWINKEL FÜR KUGELSCHNÄPPER

ANGLE BRACKET FOR BALL CATCH

Ausführung Stahl	Model Steel
Beschreibung zum flexiblen Positionieren des Kugelschnäppers	Description To flexibly position the ball catch
Material Stahl	Material Steel
Liefereinheit 10 Stück	Pack Quantity 10 pieces
Extras weitere Oberflächen, weitere Farben auf Anfrage	Specials Other surfaces, other colors on request

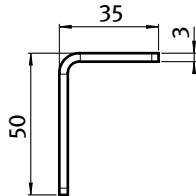
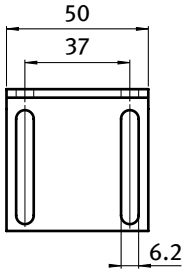

Befestigungswinkel für Kugelschnäpper
Angle Bracket for Ball Catch

Maße [mm]
Dimensions [mm]

Gewicht [g]
Weight [g]

Teil-Nr.
Part #

50 × 50 × 35

72.4

093043W

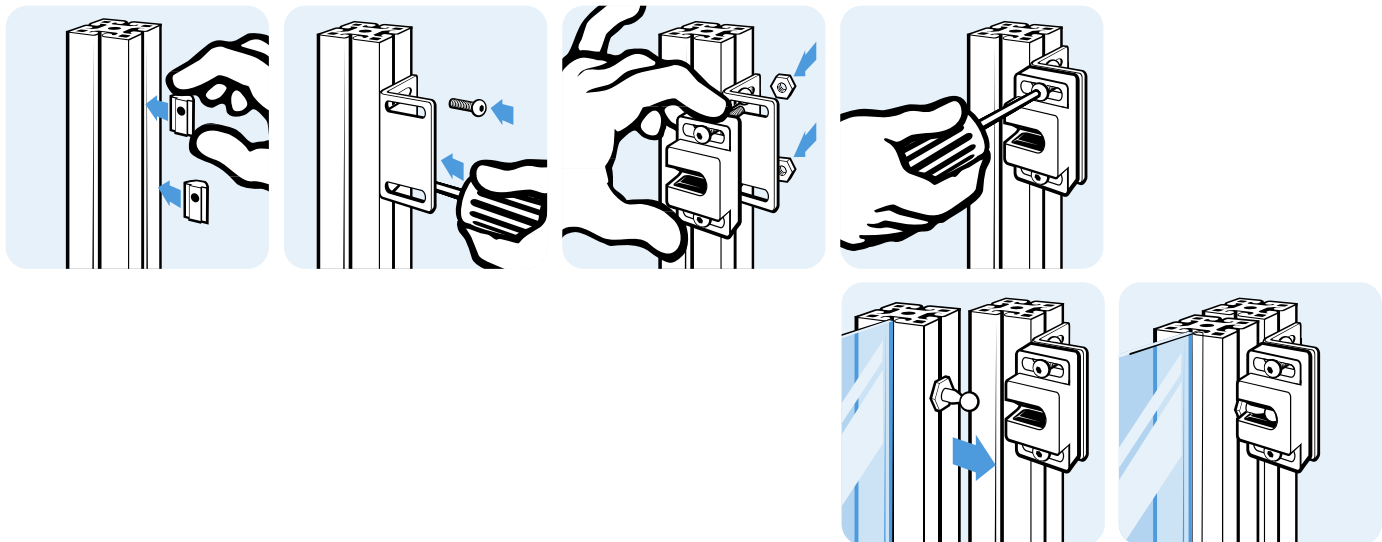

5

TÜRSCHNÄPPER (SET)

DOOR LATCH (SET)

Ausführung	Zinkdruckguss	Model	Zinc die-cast
Beschreibung	Schnellverschluss für Schwenktüren, zur Montage in einem Spalt von mindestens 12 mm zwischen Profil und Tür	Description	Quick fastener for swing doors, to be mountend in a min. 12 mm gap between door and post
Material	Türschnäpper: Zinkdruckguss Abdeckkappe: Kunststoff PA, glasfaserverstärkt 2 Senkkopfschrauben M4: Stahl	Material	Door latch: Zinc die-cast Cover cap: Plastic PA, glass fiber reinforced 2 countersunk screws M4: Steel
Farbe	Abdeckkappe: schwarz	Color	Cover cap: Black
Halteschraube	(nicht im Lieferumfang enthalten) 1 Zylinder-schraube ISO 4762 / DIN 912 - M6 - Gewindelänge abhängig von Spaltabstand und Nuttiefe, Schraubenkopf taucht komplett in den Türschnäpper ein	Counter Screw	(not included in delivery) 1 cylinder head screw ISO 4762 / DIN 912 - M6 - thread length depending on gap distance and slot depth, screw head dives competely into the door latch
Set	1 Türschnäpper, 2 Schrauben DIN 7991 (ISO 10642) - M4 × 16	Set	1 door latch, 2 screws DIN 7991 (ISO 10642) - M4 × 16
Liefereinheit	10 Stück	Pack Quantity	10 pieces
Extras	weitere Materialien, weitere Farben auf Anfrage	Specials	Other materials, other colors on request

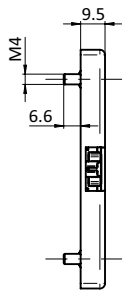
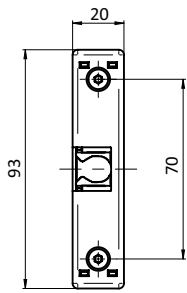

Türschnäpper (Set)
Door Latch (Set)

Verschlusskraft
Locking Force

Gewicht [g]
Weight [g]

Teil-Nr.
Part #

≈ 120 N

48.0

093039

Griffe und Verschlüsse *Handles and Latches*

Fallenverschlüsse *Slam Latches*

Kugelschnäpper *Ball Catches*



DOPPELKUGELSCHNÄPPER PA

DOUBLE BALL CATCH PA

Ausführung	Kunststoff PA	Model	Plastic PA
Beschreibung	Schnellverschluss für Türen und Klappen mit und ohne Rahmen	Description	A quick locking device for doors and flaps with and without frame
Material	Gehäuse: Kunststoff PA, glasfaserverstärkt Kugel: Edelstahl Buchse: Stahl, verzinkt	Material	Housing: Plastic PA, glass fiber reinforced Ball: Stainless steel Bushing: Steel, zinc plated
Farbe	schwarz	Color	Black
Befestigung	mit Schrauben M5	Fastening	Using M5 screws
Liefereinheit	10 Stück	Pack Quantity	10 pieces
Extras	weitere Farben auf Anfrage	Specials	Other colors on request

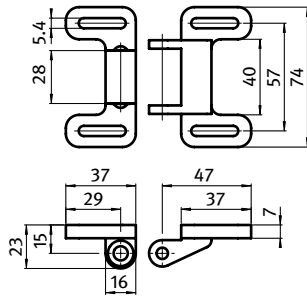

Doppelkugelschnäpper PA
Double Ball Catch PA

Verschlusskraft [N]
Locking Force [N]

Gewicht [g]
Weight [g]

Teil-Nr.
Part #

	25	38.0	09304701
elektrostatisch entladend electrostatically discharging	25	38.0	09304702

5

DOPPELKUGELSCHNÄPPER MS

DOUBLE BALL CATCH MS

Ausführung	Messing	Model	Brass
Beschreibung	Schnellverschluss für Türen, Einrastdruck verstellbar, zwei Anwendungsmöglichkeiten (seitlich / frontal)	Description	Quick catch for doors, adjustable clamping force, two possible positions (sideways / from the front)
Material	Körper: Messing Feder: Edelstahl Kugel: Edelstahl	Material	Body: Brass Spring: Stainless steel Ball: Stainless steel
Befestigung	vorderseitig mit Senkschrauben	Fastening	From the front, using countersunk screws
Liefereinheit	10 Stück	Pack Quantity	10 pieces



Doppelkugelschnäpper MS Double Ball Catch MS	A1 [mm]	A2 [mm]	B1 [mm]	B2 [mm]	C1 [mm]	C2 [mm]	D1 [mm]	D2 [mm]	Schraube Screw	Gewicht [g] Weight [g]	Teil-Nr. Part #
	44.0	24.7	8.0	6.6	35.0	15.2	11.8	9.7	M3	15.60	0930461
	49.0	28.8	8.8	7.6	39.8	19.8	13.2	10.8	M3	23.60	0930462
	60.0	35.0	11.0	9.0	50.0	23.5	15.5	13.5	M4	40.00	0930463
	68.4	40.2	13.0	12.0	58.0	30.0	18.1	15.2	M4	65.00	0930464

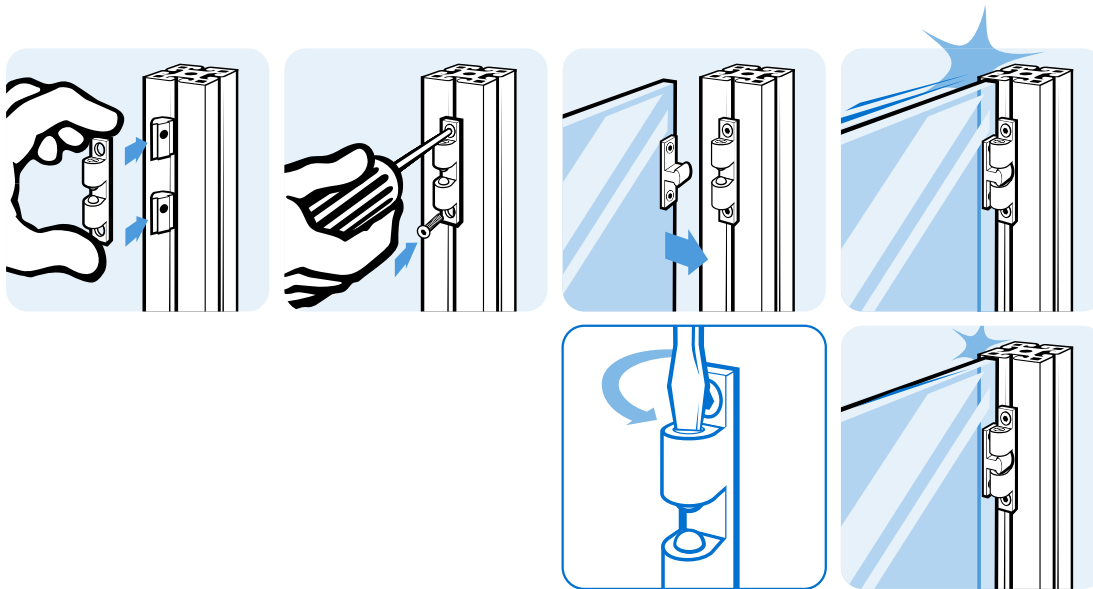

RIEGEL

DOOR LATCH

<p>Ausführung Zinkdruckguss</p> <p>Beschreibung zum leichten Verschließen von Türen und Klappen, mit gefedertem Schließzapfen; inklusive separater Nutfixierung</p> <p>Material Gehäuse: Zinkdruckguss Griff: Kunststoff PA, schwarz Bolzen: Edelstahl</p> <p>Liefereinheit 10 Stück</p>	<p>Model Zinc die-cast</p> <p>Description For easy closing of doors and flaps, with spring-loaded clamp; including separate slot fixation strips</p> <p>Material Housing: Zinc die-cast Pull handle: Plastic PA, black Bolt: Stainless steel</p> <p>Pack Quantity 10 pieces</p>
--	---

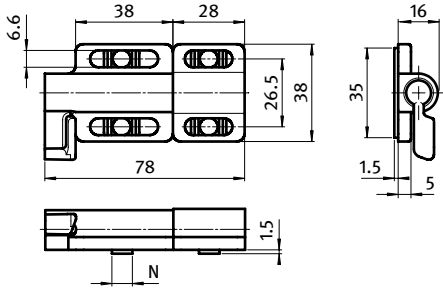

Riegel Door Latch	N	Gewicht [g] Weight [g]	Teil-Nr. Part #
	- / 8 / 10	120.0	093082

5

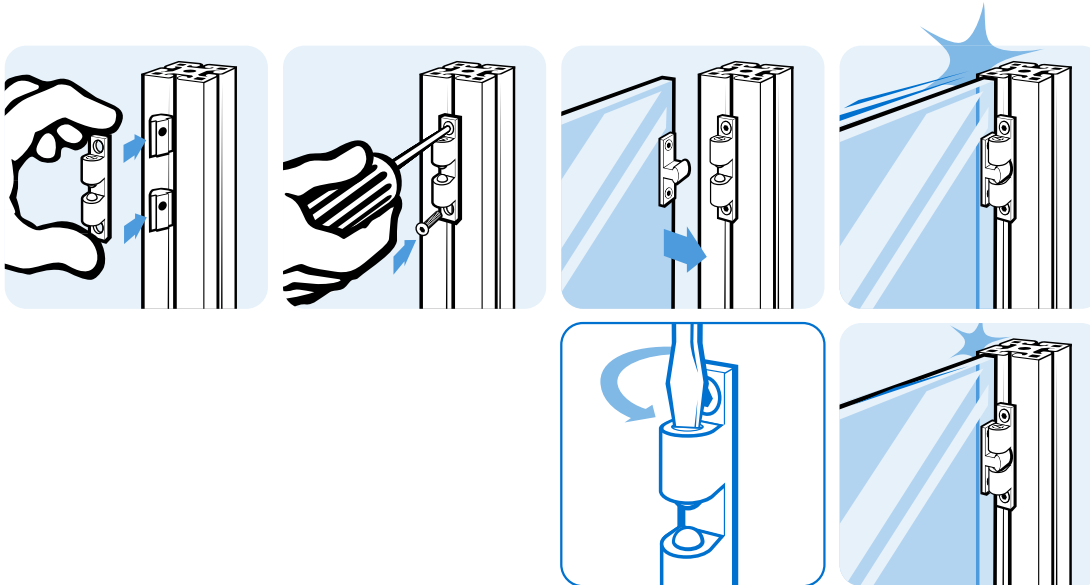



TÜRANSCHLAG MIT EPDM-DÄMPFER (SET)

DOOR STOP WITH EPDM DAMPER (SET)

Ausführung	Kunststoff PA	Model	Plastic PA
Beschreibung	einfach zu montierender Anschlag für Türen und Klappen	Description	Easy to mount stop for doors and flaps
Material	Türanschlag: Kunststoff PA, glasfaserverstärkt Dämpfer: EPDM, ≈70 Shore A Nutfixierung: Zinkdruckguss Schraube: Stahl Fixierungstück: Kunststoff PA, glasfaserverstärkt	Material	Door stop: Plastic PA, glass fiber reinforced Damper: EPDM, ≈70 Shore A Locating pin: Zinc die-cast Screw: Steel Fixation element: Plastic PA, glass fiber reinforced
Farbe	Türanschlag: schwarz Dämpfer: schwarz Fixierungstück: schwarz	Color	Door stop: Black Damper: Black Fixation element: Black
Set	1 Türanschlag mit EPDM-Dämpfer, 1 Nutfixierung, 1 Schraube ISO 7991 - M5 × 14, 1 Fixierungstück	Set	1 Door stop with EPDM Damper 1 Locating pin 1 Screw ISO 7991 - M5 × 14, 1 Fixation element
Liefereinheit	10 Stück	Pack Quantity	10 pieces
Extras	weitere Farben auf Anfrage	Specials	Other colors on request

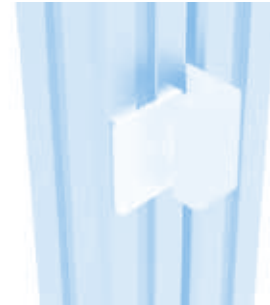
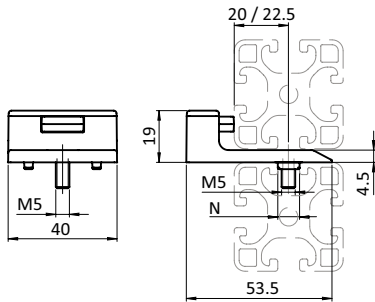

Türanschlag
Door Stop

N

Gewicht [g]
Weight [g]

Teil-Nr.
Part #

mit EPDM-Dämpfer <i>With EPDM damper</i>	8 / 10	26.0	093110
--	--------	------	--------

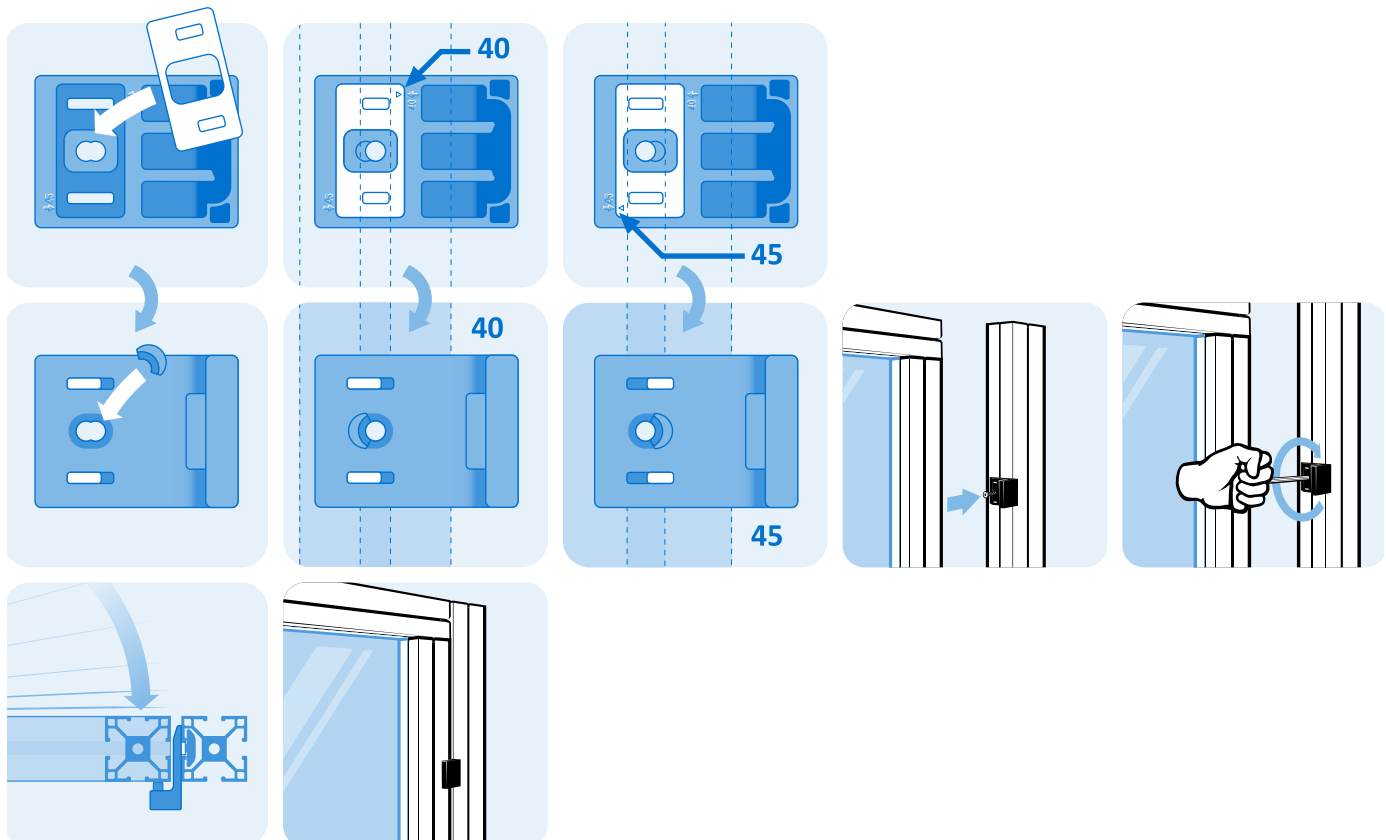



TÜRANSCHLAG MIT MAGNETVERSCHLUSS (SET)

DOOR STOP WITH MAGNETIC CATCH (SET)

Ausführung	Kunststoff PA	Model	Plastic PA
Beschreibung	einfach zu montierender Anschlag für Türen und Klappen	Description	Easy to mount stop for doors and flaps
Material	Türanschlag: Kunststoff PA, glasfaserverstärkt Magnet: Neodym Halteplatte: Stahl Nutfixierung: Zinkdruckguss Schrauben: Stahl Fixierungsstück: Kunststoff PA, glasfaserverstärkt	Material	Door stop: Plastic PA, glass fiber reinforced Magnet: Neodym Counter Plate: Steel Locating pin: Zinc die-cast Screws: Steel Fixation element: Plastic PA, glass fiber reinforced
Farbe	Türanschlag: schwarz Fixierungsstück: schwarz	Color	Door stop: Black Fixation element: Black
Set	1 Türanschlag, 1 Halteplatte 1 Nutfixierung, 2 Schrauben ISO 7991 - M5 x 14, 1 Fixierungsstück	Set	1 Door stop 1 Counter Plate 1 Locating pin 2 Screws ISO 7991 - M5 x 14, 1 Fixation element
Liefereinheit	10 Stück	Pack Quantity	10 pieces
Extras	weitere Farben auf Anfrage	Specials	Other colors on request

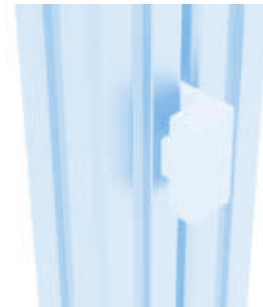
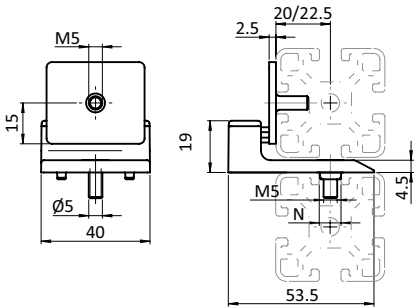

Türanschlag <i>Door Stop</i>	N	Verschlusskraft [N] <i>Locking Force [N]</i>	Gewicht [g] <i>Weight [g]</i>	Teil-Nr. <i>Part #</i>
mit Magnetverschluss <i>With magnetic catch</i>	8 / 10	30	53.0	093111

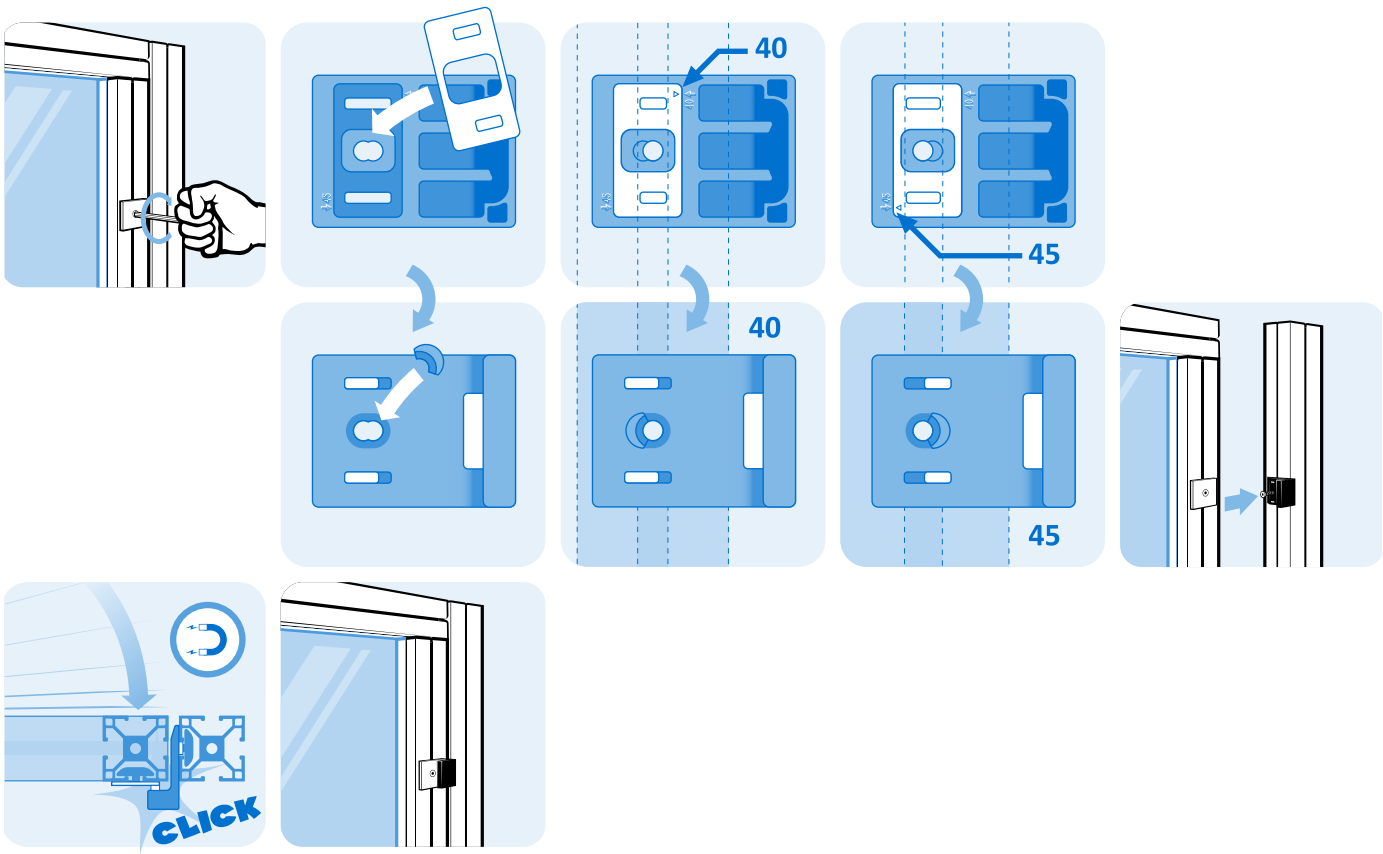



DICHTLEISTEN

SEALING STRIPS

<p>Ausführung Kunststoff PVC + TPE, Nut 8, Nut 10</p> <p>Beschreibung zum abgedichteten, bündigen und blickdichten Schließen von Türen; mit elastischer Dichtlippe, verdeckt den Türspalt</p> <p>Material Kunststoff PVC + TPE</p> <p>Farbe grau ≈ RAL 7004</p> <p>Liefereinheit 20 Meter (10 St. à 2m)</p> <p>Hinweis Bitte beachten: Sie bestellen in Meter!</p>	<p>Model Plastic PVC + TPE, Slot 8, Slot 10</p> <p>Description To close doors sealed, flush, and non see through; with elastic sealing lip, covers the door gap</p> <p>Material Plastic PVC + TPE</p> <p>Color gray ≈ RAL 7004</p> <p>Pack Quantity 20 meters (10 pieces at 2m)</p> <p>Tip Please note: You are ordering in meters!</p>
--	---



Dichtleiste Sealing Strip	N	Gewicht [g/m] Weight [g/m]	Profil Profile	Teil-Nr. Part #
für Profilkombination 30/30 <i>For profile combination 30/30</i>	8	140.0	B	092257
für Profilkombination 45/30 <i>For profile combination 45/30</i>	10	134.0	B	092258
für Profilkombination 45/45 <i>For profile combination 45/45</i>	10	180.0	B	092259

INHALTSÜBERSICHT *CONTENT OVERVIEW*



Bodenelemente <i>Floor Elements</i>	1
Scharniere <i>Hinges</i>	2
Nutmuttern und -schrauben <i>T-Nuts and T-Bolts</i>	3
Verbindungstechnik <i>Connecting Systems</i>	4
Griffe und Verschlüsse <i>Handles and Latches</i>	5
Arbeitsplatzkomponenten <i>Components for Work Stations</i>	6
Gleiter und Rollen <i>Sliders and Rollers</i>	7
Fördertechnik <i>Conveyors</i>	8
Schutz- und Trennwandelemente <i>Enclosures, Guards, Partitions</i>	9
Flächenbefestigungen <i>Panel Fasteners</i>	10
Abdeckelemente <i>Cover Elements</i>	11
Kabelführungen <i>Cable Management</i>	12
Diverse Komponenten <i>Miscellaneous Components</i>	13
Rundrohrkomponenten <i>Tubular Frame Components</i>	14



	Werkzeuggleiter	<i>Tool Hanger</i>	565
	Werkzeuggleiter	<i>Tool Hanger</i>	566
	Greifschale 105 x 130 x 50 (Set)	<i>Grab Tray</i> 105 x 130 x 50 (Set)	567
	Greifschale 105 x 130 x 50 (Set)	<i>Grab Tray</i> 105 x 130 x 50 (Set)	568
	Greifbehälter 110 / 210 x 105 x 40	<i>Grab Container</i> 110 / 210 x 105 x 40	569
	Greifbehälter 110 x 210 x 40 (Set)	<i>Grab Container</i> 110 x 210 x 40 (Set)	570
	Schalenbehälter 110 x 270 x 40 (Set)	<i>Tray Container</i> 110 x 270 x 40 (Set)	571
	Schwenkadapter für Behälter	<i>Pivoting Adapter for Containers</i>	572
	Beschriftungsclip	<i>Label Clip</i>	573
	Becherhalter	<i>Cup Holder</i>	574
	Monitorhalter	<i>Monitor Mount</i>	575
	Monitorhalter 4 Achsen, höhenverstellbar	<i>Monitor Support 4-axis, Height Adjustable</i>	576
	Monitorhalter 5 Achsen, höhenverstellbar	<i>Monitor Support 5-axis, Height Adjustable</i>	578
	Adapterplatte 40 höhenverstellbar	<i>Adapter Plate 40 Height Adjustable</i>	580



WERKZEUGGLEITER

TOOL HANGER

Ausführung	Kunststoff PA, Nut 5-6	Model	Plastic PA, Slot 5-6
Beschreibung	zum Anhängen von Werkzeugen, verbessert die Ordnung am Arbeitsplatz	Description	To hang up tools, helps to improve neatness in workshops
Material	Gleiter: Kunststoff PA, glasfaserverstärkt Karabinerhaken: Stahl, verzinkt / Edelstahl	Material	Slider: Plastic PA, glass fiber reinforced Snap Hook: Zinc plated steel / stainless steel
Liefereinheit	100 Stück	Pack Quantity	100 pieces
Extras	weitere Farben auf Anfrage	Specials	Other colors on request

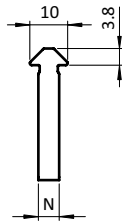
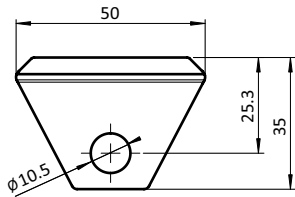

Werkzeuggleiter <i>Tool Hangers</i>	N	Maße [mm] <i>Dimensions [mm]</i>	Material	Gewicht [g] <i>Weight [g]</i>	Teil-Nr. <i>Part #</i>
Gleiter <i>Slider</i>	5/6		Kunststoff <i>Plastic</i>	9.0	093009
Karabinerhaken <i>Snap hook</i>		6 × 60	Stahl <i>Steel</i>	27.0	092020
	5/6	8 × 60	Edelstahl <i>Stainless steel</i>	68.0	092318



WERKZEUGGLEITER

TOOL HANGER

Ausführung	Kunststoff PA, Nut 8-10	Model	Plastic PA, slot 8-10
Beschreibung	zum Anhängen von Werkzeugen, verbessert die Ordnung am Arbeitsplatz	Description	To hang up tools, helps to improve neatness in workshops
Material	Gleiter: Kunststoff PA, glasfaserverstärkt Karabinerhaken: Stahl, verzinkt / Edelstahl	Material	Slider: Plastic PA, glass fiber reinforced Snap Hook: Zinc plated steel / stainless steel
Liefereinheit	100 Stück	Pack Quantity	100 pieces
Extras	weitere Farben auf Anfrage	Specials	Other colors on request

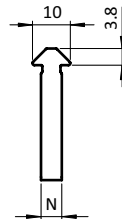
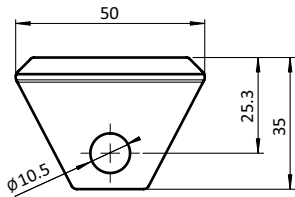

Werkzeuggleiter <i>Tool Hangers</i>	N	Maße [mm] <i>Dimensions [mm]</i>	Material	Gewicht [g] <i>Weight [g]</i>	Teil-Nr. <i>Part #</i>
Gleiter <i>Slider</i>	8/10	A=15	Kunststoff <i>Plastic</i>	9.0	093007
	8/10	A=16	Kunststoff <i>Plastic</i>	10.0	093001
	8/10	A=19	Kunststoff <i>Plastic</i>	11.0	093006
Karabinerhaken <i>Snap hook</i>		6 × 60	Stahl <i>Steel</i>	27.0	092020
	5/6	8 × 60	Edelstahl <i>Stainless steel</i>	68.0	092318

6



GREIFSCHALE 105 × 130 × 50 (SET)

GRAB TRAY 105 × 130 × 50 (SET)

Ausführung	Nut 8, 10	Model	Slot 8, 10
Beschreibung	zur Bereitstellung von Kleinteilen auf Vereinzelfläche und selektiver Aufnahme kleinster Komponenten; durch einfaches Einschwenken in die Profilnut montierbar; gut sichtbares Kennzeichnungsfeld erlaubt eine sichere Zuordnung	Description	To provide hardware and small parts on sorting area for selective grabbing of smallest components; simple assembly by swiveling into the profile slot; the clearly visible label area enables secure part identification
Material	Greifschale Standard-Ausführung: Kunststoff PA, glasfaserverstärkt Greifschale elektrostatisch entladende Ausführung: Kunststoff PA, kohlefaserverstärkt Sichtfenster: Kunststoff PC Etikett: Karton 250 g/m ² Elastikpuffer: Kunststoff PU, ≈ 65-70 Shore A	Material	Grab tray standard version: Plastic PA, glass fiber reinforced Grab tray electrostatically discharging version: Plastic PA, carbon fiber reinforced Label window: Plastic PC Label: Carton 250 g/m ² Bumper: Plastic PU, ≈ 65-70 Shore A
Set	1 Greifschale, 1 Sichtfenster, 1 Etikett, 4 Elastikpuffer, selbstklebend	Set	1 grab tray, 1 label window, 1 label, 4 bumper, self-adhesive
Liefereinheit	10 Stück	Pack Quantity	10 pieces
Extras	weitere Farben auf Anfrage	Specials	Other colors on request

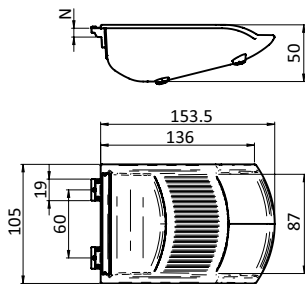

Greifschale 105 × 130 × 50 (Set) Grab Tray 105 × 130 × 50 (Set)	N	Farbe	Gewicht [g] Weight [g]	Teil-Nr. Part #
	8	schwarz <i>Black</i>	120.1	061MGT2D391N08
elektrostatisch entladend <i>electrostatically discharging</i>	8	schwarz <i>Black</i>	102.4	061MGT2D391N08ESD
	8	gelb ≈ RAL 1003 <i>Yellow</i>	120.1	061MGT2D311N08
	8	rot ≈ RAL 3020 <i>Red</i>	120.1	061MGT2D331N08
	8	grün ≈ RAL 6032 <i>Green</i>	120.1	061MGT2D361N08
	8	grau ≈ RAL 7042 <i>Gray</i>	120.1	061MGT2D374N08
	10	schwarz <i>Black</i>	120.7	061MGT2D391N10
elektrostatisch entladend <i>electrostatically discharging</i>	10	schwarz <i>Black</i>	106.1	061MGT2D391N10ESD
	10	gelb ≈ RAL 1003 <i>Yellow</i>	120.7	061MGT2D311N10
	10	rot ≈ RAL 3020 <i>Red</i>	120.7	061MGT2D331N10
	10	grün ≈ RAL 6032 <i>Green</i>	120.7	061MGT2D361N10
	10	grau ≈ RAL 7042 <i>Gray</i>	120.7	061MGT2D374N10



GREIFSCHALE 105 × 130 × 50 (SET)

GRAB TRAY 105 × 130 × 50 (SET)

Ausführung	für Einhängeprofil	Model	For suspension profile
Beschreibung	zur Bereitstellung von Kleinteilen auf Vereinzelungsfläche und selektiven Aufnahme kleinster Komponenten; an Einhängeprofil montierbar, durch Einhacken auch in Lochplatten montierbar; gut sichtbares Kennzeichnungsfeld erlaubt eine sichere Zuordnung	Description	To provide hardware and small parts on sorting area for selective grabbing of smallest components; simple assembly by swiveling into into the suspension profile or grid plate; the clearly visible label area enables secure part identification
Material	Standard-Ausführung: Kunststoff PA, glasfaserverstärkt ⚡ elektrostatisch entladende Ausführung: Kunststoff PA, kohlefaserverstärkt	Material	Standard version: Plastic PA, glass fiber reinforced ⚡ electrostatically discharging version: Plastic PA, carbon fiber reinforced
Set	1 Greifschale, 1 Sichtfenster, 1 Etikett, 4 Elastikpuffer, selbstklebend	Set	1 grab tray, 1 label window, 1 label, 4 bumper, self-adhesive
Liefereinheit	10 Stück	Pack Quantity	10 pieces
Extras	weitere Farben auf Anfrage	Specials	Other colors on request

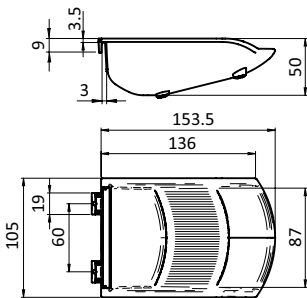

Greifschale 105 × 130 × 50 (Set)
Grab Tray 105 × 130 × 50 (Set)

	Farbe	Gewicht [g] Weight [g]	Teil-Nr. Part #
	schwarz Black	118.5	061MGT2D391H
elektrostatisch entladend ⚡ electrostatically discharging	schwarz Black	97.4	061MGT2D391HESD
	gelb ≈ RAL 1003 Yellow	118.5	061MGT2D311H
	rot ≈ RAL 3020 Red	118.5	061MGT2D331H
	grün ≈ RAL 6032 Green	118.5	061MGT2D361H
	grau ≈ RAL 7042 gray	118.5	061MGT2D374H



GREIFBEHÄLTER 110 / 210 × 105 × 40

GRAB CONTAINER 110 / 210 × 105 × 40

Ausführung	Nut 8, 10	Model	Slot 8, 10
Beschreibung	zur Bereitstellung von bevorrateten Kleinteilen; durch einfaches Einschwenken in die Profilvernut montierbar, optionale Fixiermöglichkeit mittels 1 oder 2 Schrauben M5	Description	To store and provide small parts; simple assembly by swiveling into the profile slot, optional fixation possibility using 1 or 2 screws M5
Material	Kunststoff PA, glasfaserverstärkt	Material	Plastic PA, glass fiber reinforced
Farbe	schwarz	Color	Black
Liefereinheit	10 Stück	Pack Quantity	10 pieces
Extras	weitere Farben auf Anfrage	Specials	Other colors on request

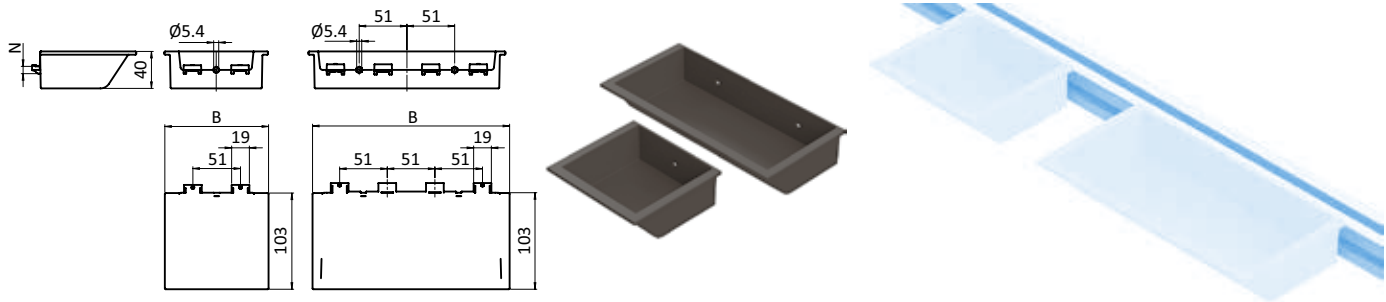

Greifbehälter 110 / 210 × 105 × 40 Grab Container 110 / 210 × 105 × 40	B [mm]	N	Gewicht [g] Weight [g]	Profil Profile	Teil-Nr. Part #
	110	8	95.2	I	061MGC2D291N08
	110	10	97.2	B	061MGC2D291N10
	210	8	190.8	I	061MGC4D291N08
	210	10	194.1	B	061MGC4D291N10



GREIFBEHÄLTER 110 × 210 × 40 (SET)

GRAB CONTAINER 110 × 210 × 40 (SET)

<p>Ausführung für Einhängeprofil</p> <p>Beschreibung zur Bereitstellung von bevorrateten Kleinteilen; an Einhängeprofil montierbar, mit optionalem Adapter auch schwenkbar in der Profilvernuth montierbar; gut sichtbares Kennzeichnungsfeld erlaubt eine sichere Zuordnung; stapelbar</p> <p>Material Greifbehälter Standard-Ausführung: Kunststoff PA, glasfaserverstärkt Greifbehälter elektrostatisch entladende Ausführung: Kunststoff PA, kohlefaserverstärkt Sichtfenster: Kunststoff PC Etikett: Karton 250 g/m²</p> <p>Farbe Greifbehälter: schwarz Sichtfenster: transparent</p> <p>Set 1 Greifbehälter, 1 Sichtfenster, 1 Etikett</p> <p>Liefereinheit 10 Stück</p> <p>Extras weitere Farben auf Anfrage</p> <p>Hinweis passender Schwenkadapter für Profilvernuth siehe Seite 572</p>	<p>Model For suspension profile</p> <p>Description To store and provide small parts; simple assembly by swiveling into the suspension profile, optional adapter allows for horizontally pivoting fixation; the clearly visible label area enables secure part identification; stackable</p> <p>Material Grab container standard version: Plastic PA, glass fiber reinforced Grab container electrostatically discharging version: Plastic PA, carbon fiber reinforced Label window: Plastic PC Label: Carton 250 g/m²</p> <p>Color Grab container: Black Label window: Transparent</p> <p>Set 1 grab container, 1 label window, 1 label</p> <p>Pack Quantity 10 pieces</p> <p>Specials Other colors on request</p> <p>Tip Compatible swivel adapter for profile slot see page 572</p>
--	---

6

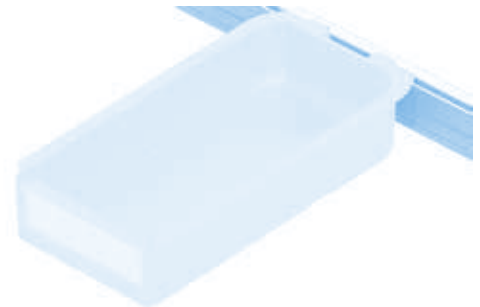
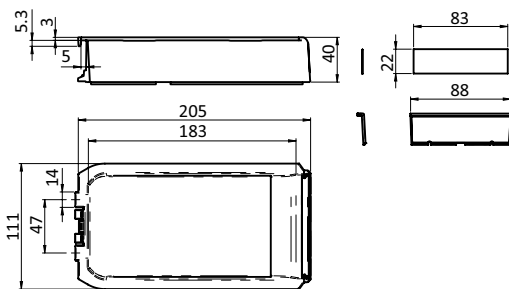

Greifbehälter 110 × 210 × 40 (Set)
Grab Container 110 × 210 × 40 (Set)

Gewicht [g]
Weight [g]

Teil-Nr.
Part #

	175.5	061MGC2K291H
elektrostatisch entladend electrostatically discharging	150.0	061MGC2K291HESD

SCHALENBEHÄLTER 110 × 270 × 40 (SET)

TRAY CONTAINER 110 × 270 × 40 (SET)

<p>Ausführung für Einhängprofil</p> <p>Beschreibung zur Bereitstellung von bevorrateten Kleinteilen mit Vereinzelungsfläche; an Einhängprofil montierbar, mit optionalem Adapter auch waagrecht schwenkbar in der Profilnut montierbar; gut sichtbares Kennzeichnungsfeld erlaubt eine sichere Zuordnung; stapelbar</p> <p>Material Schalenbehälter Standard-Ausführung: Kunststoff PA, glasfaserverstärkt Schalenbehälter elektrostatisch entladende Ausführung: Kunststoff PA, kohlefaserverstärkt Sichtfenster: Kunststoff PC Etikett: Karton 250 g/m²</p> <p>Farbe Schalenbehälter: schwarz Sichtfenster: transparent</p> <p>Set 1 Schalenbehälter, 1 Sichtfenster, 1 Etikett</p> <p>Liefereinheit 10 Stück</p> <p>Extras weitere Farben auf Anfrage</p> <p>Hinweis passender Schwenkadapter für Profilnut siehe Seite 572</p>	<p>Model For suspension profile</p> <p>Description To store and provide small parts, with sorting area; simple assembly by swiveling into the suspension profile, optional adapter allows for horizontally pivoting fixation; the clearly visible label area enables secure parte identification; stackable</p> <p>Material Tray container standard version: Plastic PA, glass fiber reinforced Tray container electrostatically discharging version: Plastic PA, carbon fiber reinforced Label window: Plastic PC Label: Carton 250 g/m²</p> <p>Color Tray container: Black Label window: Transparent</p> <p>Set 1 tray container, 1 label window, 1 label</p> <p>Pack Quantity 10 pieces</p> <p>Specials Other colors on request</p> <p>Tip Compatible swivel adapter for profile slot see page 572</p>
--	---

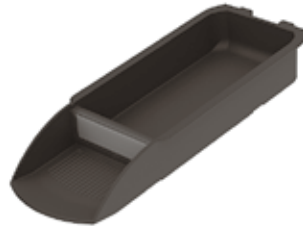
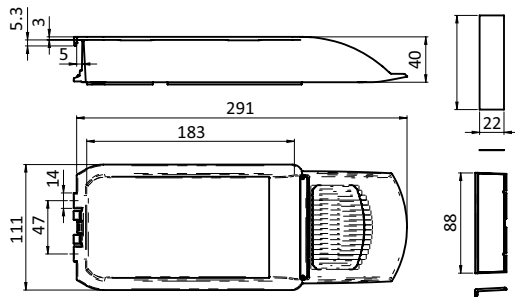

<p>Schalenbehälter 110 × 270 × 40 (Set) Tray Container 110 × 270 × 40 (Set)</p>	<p>Gewicht [g] Weight [g]</p>	<p>Teil-Nr. Part #</p>
	219.3	061MTC2K291H
elektrostatisch entladend electrostatically discharging	186.7	061MTC2K291HESD



SCHWENKADAPTER FÜR BEHÄLTER

PIVOTING ADAPTER FOR CONTAINERS

<p>Ausführung Nut 8, 10, für Greifbehälter 110 × 210 × 40 und Schalenbehälter 110 × 270 × 40</p> <p>Beschreibung zur Befestigung von Greif- und Schalenbehälter an Profilvernuten, mit separaten Nutfixierungen Nut 8 und Nut 10; schwenkbar in beide Richtungen bis zu 45°, Schwenkbereich waagrecht verstellbar indem Feststellschraube gelöst wird</p> <p>Material Gehäuse Standard-Ausführung: Kunststoff PA, glasfaserverstärkt Gehäuse elektrostatisch entladende Ausführung: Kunststoff PA, kohlefaserverstärkt Adapter Standard-Ausführung: Kunststoff PA, glaskugelverstärkt Adapter elektrostatisch entladende Ausführung: Kunststoff PA, kohlefaserverstärkt Fixierung: Zinkdruckguss Befestigungsmaterial: Stahl</p> <p>Farbe Gehäuse: schwarz Adapter: schwarz</p> <p>Liefereinheit 10 Stück</p> <p>Extras weitere Farben auf Anfrage</p> <p>Hinweis passender Greifbehälter siehe Seite 570; passender Schalenbehälter siehe Seite 571</p>	<p>Model Slot 8, 10, for grab containers 110 × 210 × 40 and tray containers 110 × 270 × 40</p> <p>Description To fix grab containers and grab trays on profile slots; with separate slot fixing for slot 8 and slot 10; pivotable in two directions up to 45°; with locking screw for enabling or disabling horizontal pivoting</p> <p>Material Housing standard version: Plastic PA, glass fiber reinforced Housing electrostatically discharging version: Plastic PA, carbon fiber reinforced Adapter standard version: Plastic PA, glass ball reinforced Adapter electrostatically discharging version: Plastic PA, carbon fiber reinforced Centering pieces: Zinc die-cast Mounting material: Steel</p> <p>Color Housing: Black Adapter: Black</p> <p>Pack Quantity 10 pieces</p> <p>Specials Other colors on request</p> <p>Tip Compatible Grab Container see page 570; Compatible Tray Container see page 571</p>
---	--

6

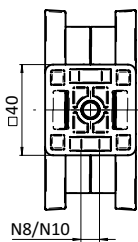
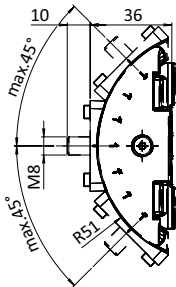

Schwenkadapter für Behälter
Pivoting Adapter for containers

Gewicht [g]
Weight [g]

Teil-Nr.
Part #

	75.4	061MA2291NS01
elektrostatisch entladend <i>electrostatically discharging</i>	64.3	061MA2291NESDS01



BESCHRIFTUNGSClip

LABEL CLIP

Ausführung	für Profile mit Nut 8, 10	Model	For profiles with slot 8, 10
Beschreibung	zum Beschriften von Profilen - mit 30 mm: für Etikettenhöhe 23 mm (max. 26 mm) - mit ≥ 40 mm: für Etikettenhöhe 36 mm (max. 38 mm)	Description	For labelling on profiles - with 30 mm: for labels with 23 mm (max. 26 mm) height - with ≥ 40 mm: for labels with 36 mm (max. 38 mm) height
Material	Kunststoff PVC	Material	Plastic PVC
Farbe	grau ≈ RAL 7035 / transparent	Color	gray ≈ RAL 7035 / transparent
Liefereinheit	20 Stück (à 102 mm / à 160 mm) oder 20 Meter (10 Stück á 2 m)	Pack Quantity	20 pieces (at 102 mm / at 160 mm) or 20 meters (10 pieces at 2 m)
Hinweis	*Bitte beachten: Sie bestellen in Meter!	Tip	*Please note: You are ordering in meters!



Beschriftungsclip Label Clip	E [mm]	H [mm]	L [mm]	N	für Profil [mm] for Profile [mm]	Gewicht [g] Weight [g]	Profil Profile	Teil-Nr. Part #
23 (max. 26)	23	28	102	8	30	6.0	B	093LC23N08S01.102
23 (max. 26)	23	28	*2000	8	30	126.0	B	093LC23N08S01.2000
36 (max. 38)	36	40	102	8 + 10	≥ 40	12.0		093LC36N0810S01.102
36 (max. 38)	36	40	160	8 + 10	≥ 40	16.0		093LC36N0810S01.160
36 (max. 38)	36	40	*2000	8 + 10	≥ 40	190.0		093LC36N0810S01.2000

BECHERHALTER

CUP HOLDER

Ausführung	Kunststoff PA	Model	Plastic PA
Beschreibung	zum sicheren Abstellen einer Flasche, Dose oder Tasse oder zum Abhängen eines Gerätes (z.B. Bohrmaschine)	Description	To securely put down a bottle, can or cup, or to park a tool (e.g. a drill)
Material	Kunststoff PA, glasfaserverstärkt	Material	Plastic PA, glass fiber reinforced
Farbe	schwarz, rot	Color	Black, red
Befestigung	mit Senkschrauben M5	Fastening	M5 countersunk screws
Liefereinheit	1 Stück	Pack Quantity	1 piece
Extras	weitere Farben auf Anfrage	Specials	Other colors on request

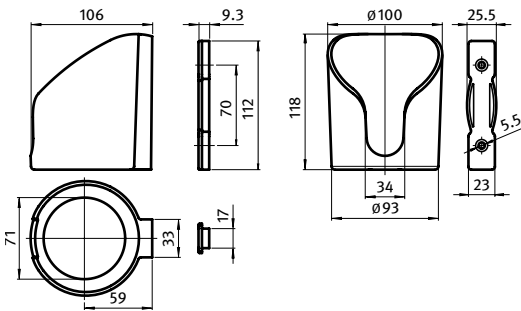

Becherhalter
Cup Holder

Gewicht [g]
Weight [g]

Teil-Nr.
Part #

	145.6	09308901
	145.6	09308901S01
	157.0	09308902
elektrostatisch entladend electrostatically discharging	149.5	09308902S01



MONITORHALTER

MONITOR MOUNT

<p>Ausführung schwenkbar</p> <p>Beschreibung zur beweglichen Befestigung von Flachbildschirmen an Profilkonstruktionen, VESA MIS-D 75/100 kompatibel, horizontal und vertikal zum Blickbereich ausrichtbar</p> <p>Material Monitorhalter: Kunststoff PA, glasfaserverstärkt Gelenkhälfte: Kunststoff PA, glaskugelverstärkt Nutfixierung: Kunststoff PA, glasfaserverstärkt Befestigungsmaterial: Stahl</p> <p>Farbe Monitorhalter: schwarz Gelenkhälfte: grau Nutfixierung: blank</p> <p>Liefereinheit 10 Stück</p> <p>Extras weitere Farben, weitere Größen auf Anfrage</p>	<p>Model Swivelling</p> <p>Description To fix flat screens to aluminum profile structures, VESA MIS-D 75/100 compatible, can be adjusted horizontally and vertically for optimum visibility</p> <p>Material Monitor bracket: Plastic PA, glass fiber reinforced Articulation piece: Plastic PA, glass fiber reinforced Centering piece: Plastic PA, glass fiber reinforced Mounting material: Steel</p> <p>Color Monitor bracket: Black Articulation piece: Gray Centering piece: Plain</p> <p>Pack Quantity 10 pieces</p> <p>Specials Other colors, other sizes on request</p>
--	--

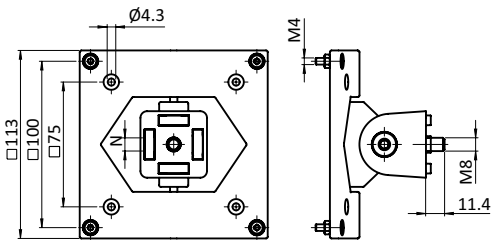

Monitorhalter Monitor Mount	F [N]	N	Gewicht [g] Weight [g]	Teil-Nr. Part #
	110	- / 8 / 10	200.0	061SM7510040



MONITORHALTER 4 ACHSEN, HÖHENVERSTELLBAR

MONITOR SUPPORT 4-AXIS, HEIGHT ADJUSTABLE

<p>Ausführung 4 Achsen</p> <p>Beschreibung einsatzfertiger Monitorhalter mit beigelegter Befestigungsplatte inkl. Flansch zur Befestigung an vertikalen oder horizontalen Profilen; 360° drehbar (vertikal); für Monitore mit genormtem VESA-Anschluss (VESA 75 und 100); einstellbare Last 2 –10 kg</p> <p>Material Befestigungsplatte VESA, abnehmbar: Stahl / Kunststoff Monitorhalter: Aluminiumdruckguss Abdeckung Kabelführung: Kunststoff Lagerscheiben und -hülsen: Kunststoff Montage-Flansch: Aluminiumdruckguss Montage-Adapter: Aluminiumdruckguss Schrauben: Stahl</p> <p>Farbe Befestigungsplatte VESA, abnehmbar: alufarbig / schwarz Monitorhalter: alufarbig Abdeckung Kabelführung: schwarz Lagerscheiben und -hülsen: schwarz Montage-Flansch: alufarbig Montage-Adapter: alufarbig</p> <p>Oberfläche Befestigungsplatte VESA, abnehmbar: lackiert Monitorhalter: lackiert Montage-Flansch: lackiert Montage-Adapter: lackiert Schrauben: verzinkt</p> <p>Set 1 Befestigungsplatte VESA inklusive 4 Schrauben – M4 × 12, Kreuzschlitz 1 Monitorhalter 4 Achsen inklusive Abdeckung Kabelführung 1 Montage-Flansch 1 Montageschraube DIN 6912 – M8 × 25 1 Montage-Adapter 2 Montageschrauben DIN 6912 – M8 × 16 1 Sechskantschlüssel, SW 3 1 Sechskantschlüssel, SW 4</p> <p>Liefereinheit 1 Stück</p>	<p>Model 4-axis</p> <p>Description Ready-to use monitor support with flanged fixation plate for attaching on vertical or horizontal aluminum profiles; (vertically) pivotable 360°; for monitors with standard VESA connection (VESA 75 and 100); adjustable load 2 – 10 kg</p> <p>Material Mounting plate VESA, removable: Steel / Plastic Monitor mount: Die-cast aluminum Cable management cover: Plastic Bearing shims and bushes: Plastic Mounting flange: Die-cast aluminum Mounting adapter: Die-cast aluminum Screws: Steel</p> <p>Color Mounting plate VESA, removable: Alu color / black Monitor mount: Alu color Cable management cover: Black Bearing shims and bushes: Black Mounting flange: Alu color Mounting adapter: alu color</p> <p>Surface Mounting plate VESA, removable: Lacquered Monitor mount: Lacquered Mounting flange: Lacquered Mounting adapter: Lacquered Screws: Zinc plated</p> <p>Set 1 mounting plate VESA with 4 screws – M4 × 12, Phillips 1 monitor support 4-axis with cable management cover 1 mounting flange 1 mounting screw DIN 6912 – M8 × 25 1 mounting adapter 2 mounting screws DIN 6912 – M8 × 16 1 hexagon key, SW 3 1 hexagon key, SW 4</p> <p>Pack Quantity 1 piece</p>
--	---

6



MONITORHALTER 4 ACHSEN, HÖHENVERSTELLBAR

MONITOR SUPPORT 4-AXIS, HEIGHT ADJUSTABLE

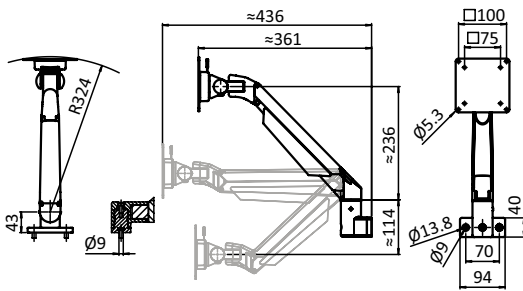

Monitorhalter 4 Achsen, höhenverstellbar
 Monitor Support 4-axis, Height Adjustable

Gewicht [g]
 Weight [g]

Teil-Nr.
 Part #

2200.0

6MHM75100S40

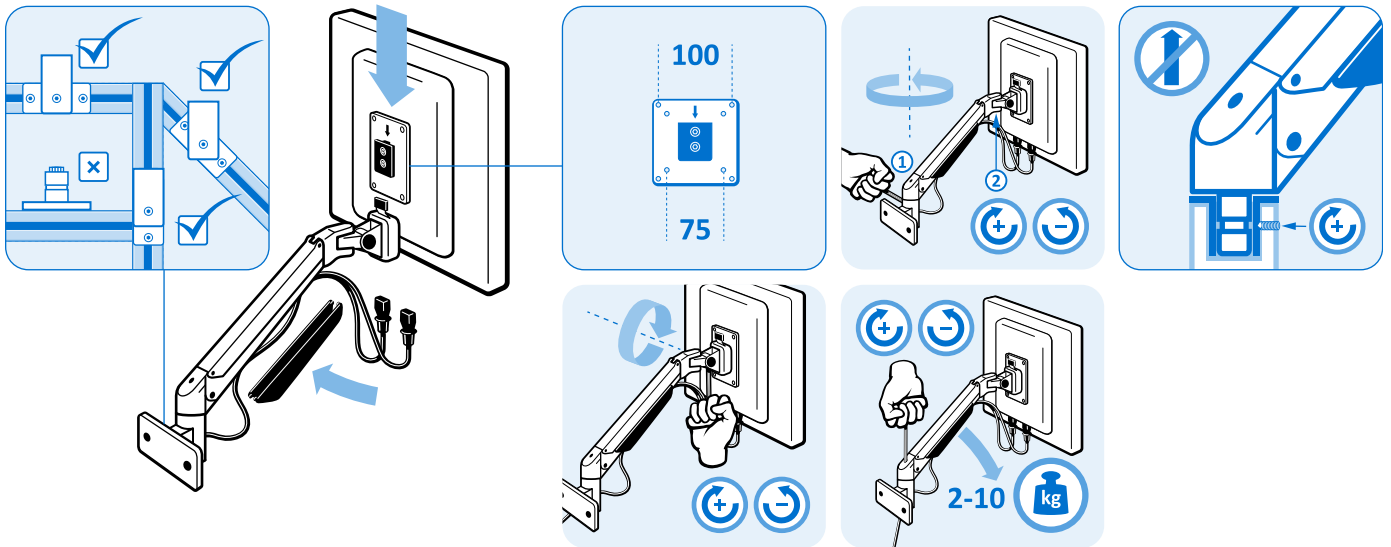



MONITORHALTER 5 ACHSEN, HÖHENVERSTELLBAR

MONITOR SUPPORT 5-AXIS, HEIGHT ADJUSTABLE

<p>Ausführung 5 Achsen</p> <p>Beschreibung einsatzfertiger Monitorhalter mit beigelegter Befestigungsplatte inkl. Flansch zur Befestigung an vertikalen oder horizontalen Profilen oder auf Flächen; 360° drehbar (vertikal); für Monitore mit normtem VESA-Anschluss (VESA 75 und 100); einstellbare Last 2 –10 kg</p> <p>Material Befestigungsplatte VESA, abnehmbar: Stahl / Kunststoff Monitorhalter: Aluminiumdruckguss Abdeckung Kabelführung: Kunststoff Lagerscheiben und -hülsen: Kunststoff Montage-Flansch: Aluminiumdruckguss Montage-Adapter: Aluminiumdruckguss Schrauben: Stahl</p> <p>Farbe Befestigungsplatte VESA, abnehmbar: alufarbig / schwarz Monitorhalter: alufarbig Abdeckung Kabelführung: schwarz Lagerscheiben und -hülsen: schwarz Montage-Flansch: alufarbig Montage-Adapter: alufarbig</p> <p>Oberfläche Befestigungsplatte VESA, abnehmbar: lackiert Monitorhalter: lackiert Montage-Flansch: lackiert Montage-Adapter: lackiert Schrauben: verzinkt</p> <p>Set 1 Befestigungsplatte VESA inklusive 4 Schrauben – M4 × 12, Kreuzschlitz 1 Monitorhalter 5 Achsen inklusive Abdeckung Kabelführung 1 Montage-Flansch 1 Montageschraube DIN 6912 – M8 × 25 1 Montage-Adapter 2 Montageschrauben DIN 6912 – M8 × 16 1 Sechskantschlüssel, SW 3 1 Sechskantschlüssel, SW 4</p> <p>Liefereinheit 1 Stück</p>	<p>Model 5-axis</p> <p>Description Ready-to use monitor support with flanged fixation plate for attaching on vertical or horizontal aluminum profiles or on plane surfaces; (vertically) pivotable 360°; for monitors with standard VESA connection (VESA 75 and 100); adjustable load 2 – 10 kg</p> <p>Material Mounting plate VESA, removable: Steel / Plastic Monitor mount: Die-cast aluminum Cable management cover: Plastic Bearing shims and bushes: Plastic Mounting flange: Die-cast aluminum Mounting adapter: Die-cast aluminum Screws: Steel</p> <p>Color Mounting plate VESA, removable: Alu color / black Monitor mount: Alu color Cable management cover: Black Bearing shims and bushes: Black Mounting flange: Alu color Mounting adapter: alu color</p> <p>Surface Mounting plate VESA, removable: Lacquered Monitor mount: Lacquered Mounting flange: Lacquered Mounting adapter: Lacquered Screws: Zinc plated</p> <p>Set 1 mounting plate VESA with 4 screws – M4 × 12, Phillips 1 monitor support 4-axis with cable management cover 1 mounting flange 1 mounting screw DIN 6912 – M8 × 25 1 mounting adapter 2 mounting screws DIN 6912 – M8 × 16 1 hexagon key, SW 3 1 hexagon key, SW 4</p> <p>Pack Quantity 1 piece</p>
---	--

6



MONITORHALTER 5 ACHSEN, HÖHENVERSTELLBAR

MONITOR SUPPORT 5-AXIS, HEIGHT ADJUSTABLE

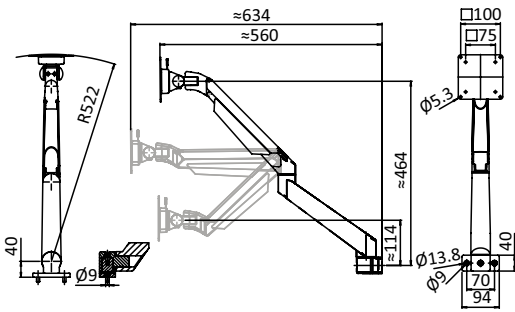

Monitorhalter 5 Achsen, höhenverstellbar
 Monitor Support 5-axis, Height Adjustable

Gewicht [g]
 Weight [g]

Teil-Nr.
 Part #

2930.0

6MHM75100D40

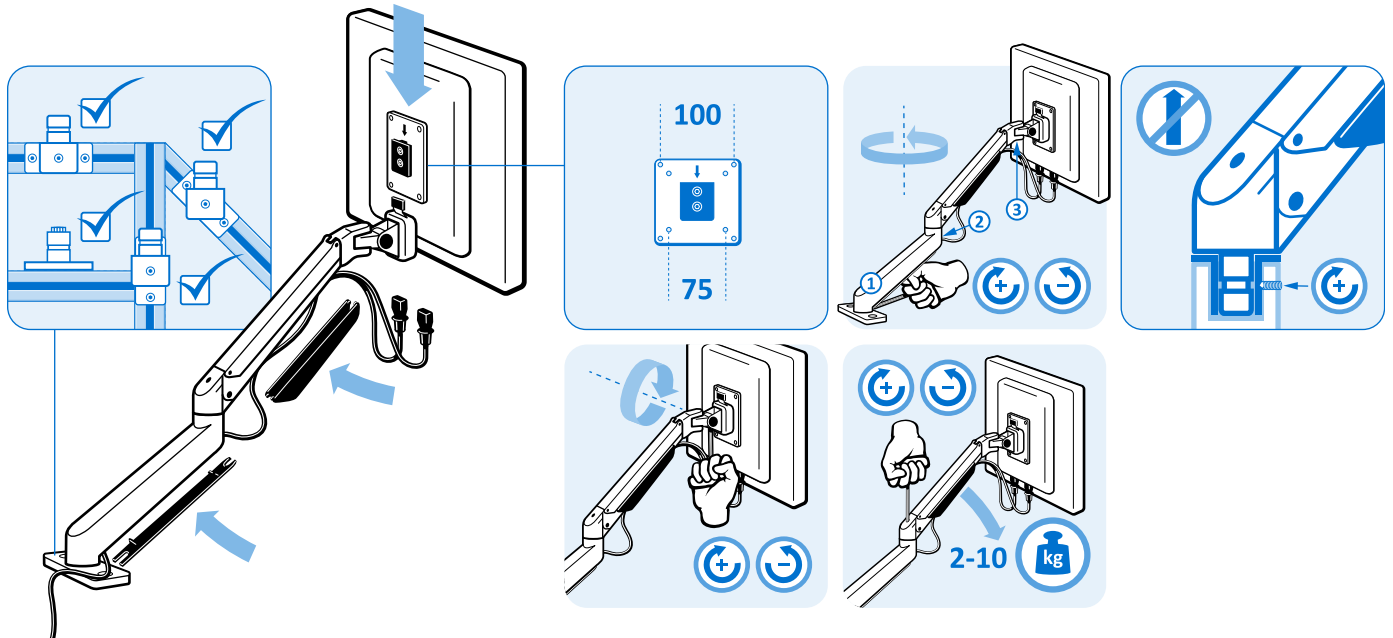

ADAPTERPLATTE 40 HÖHENVERSTELLBAR

ADAPTER PLATE 40 HEIGHT ADJUSTABLE

<p>Ausführung Aluminiumdruckguss</p> <p>Beschreibung zur rechtwinkligen Verbindung von einem Monitorhalter oder von einem Aluminiumprofil, sowie zum Herstellen einer T-Verbindung zwischen zwei Aluminiumprofilen; durch zugängliche Anschraubbohrungen ist die Position nachträglich verstellbar</p> <p>Material Adapterplatte: Aluminiumdruckguss Einpressmutter: Stahl</p> <p>Oberfläche Adapterplatte: alufarbig pulverbeschichtet Einpressmutter: verzinkt</p> <p>Liefereinheit 10 Stück</p> <p>Hinweis passender Monitorhalter siehe Seite 575</p>	<p>Model Die-cast aluminum</p> <p>Description To connect a monitor mount or an aluminum profile at right angles, as well to tee connect two aluminum profiles; accessible mounting holes allow to adjust the position later</p> <p>Material Adapter plate: Die cast aluminum Pressed nut: Steel</p> <p>Surface Adapter plate: Alu color powder coated Pressed nut: Zinc plated</p> <p>Pack Quantity 10 pieces</p> <p>Tip Compatible monitor mount see page 575</p>
---	--

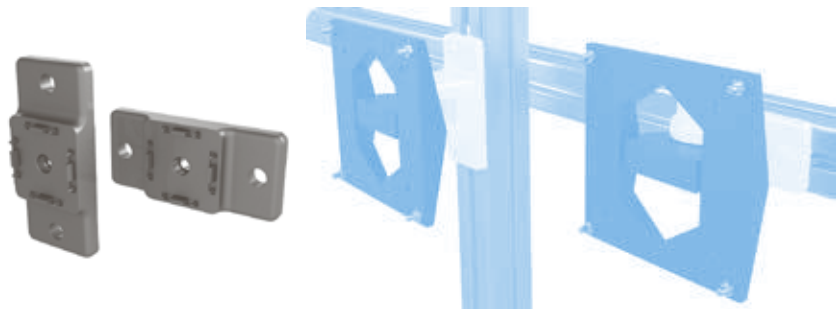
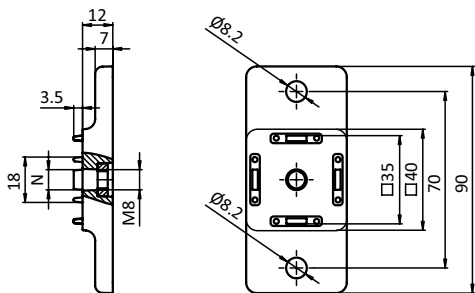

Adapterplatte 40 höhenverstellbar Adapter Plate 40 Height Adjustable	N	Gewicht [g] Weight [g]	Profil Profile	Teil-Nr. Part #
	8	64.0	I	061SAP40H

INHALTSÜBERSICHT *CONTENT OVERVIEW*

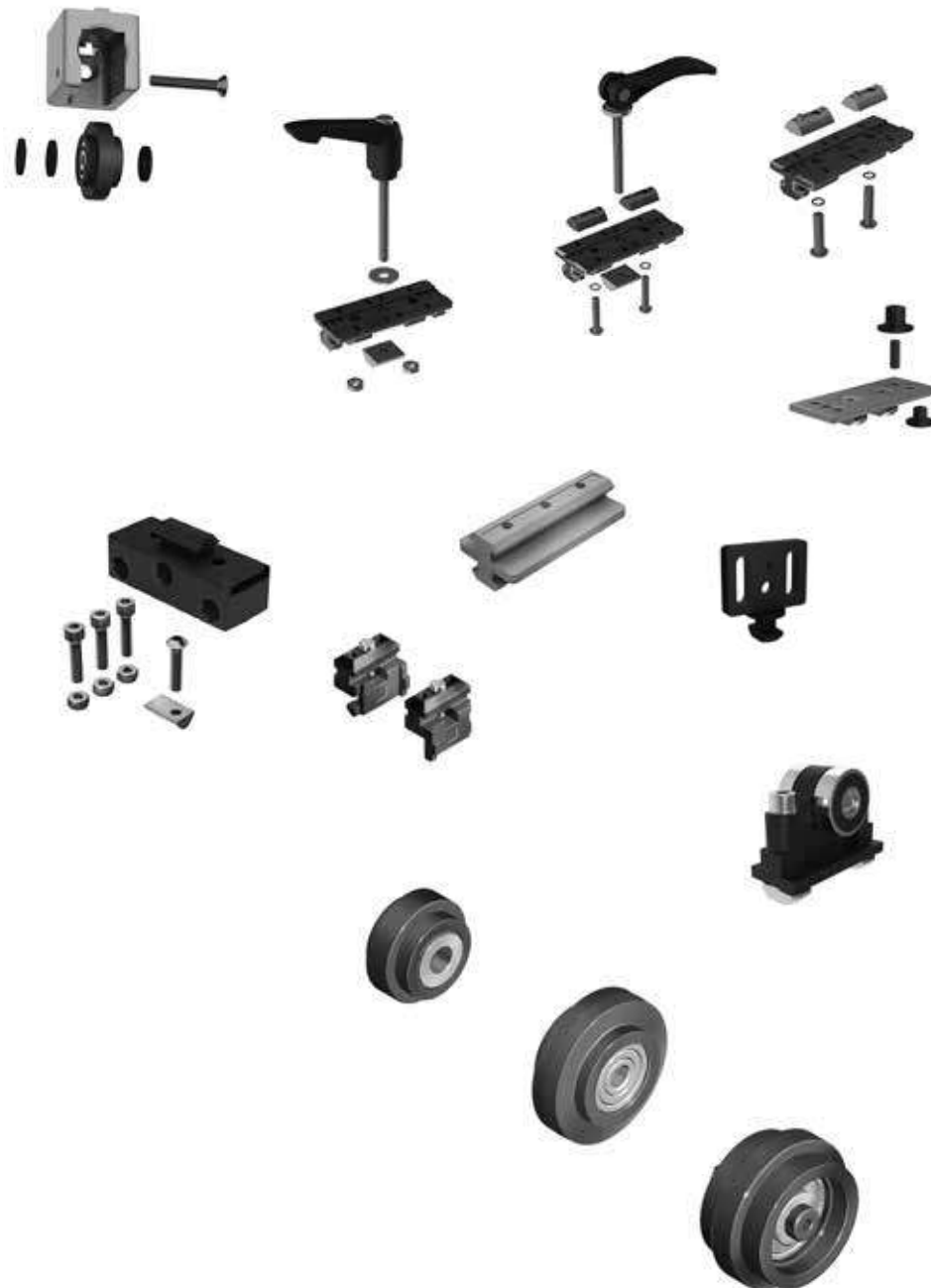

Bodenelemente <i>Floor Elements</i>	1
Scharniere <i>Hinges</i>	2
Nutmuttern und -schrauben <i>T-Nuts and T-Bolts</i>	3
Verbindungstechnik <i>Connecting Systems</i>	4
Griffe und Verschlüsse <i>Handles and Latches</i>	5
Arbeitsplatzkomponenten <i>Components for Work Stations</i>	6
Gleiter und Rollen <i>Sliders and Rollers</i>	7
Fördertechnik <i>Conveyors</i>	8
Schutz- und Trennwandelemente <i>Enclosures, Guards, Partitions</i>	9
Flächenbefestigungen <i>Panel Fasteners</i>	10
Abdeckelemente <i>Cover Elements</i>	11
Kabelführungen <i>Cable Management</i>	12
Diverse Komponenten <i>Miscellaneous Components</i>	13
Rundrohrkomponenten <i>Tubular Frame Components</i>	14

	Profilgleiter ZN 40 x 80 (Set)	<i>Profile Slider ZN 40 x 80 (Set)</i>	583		Rolle ø29	<i>Roller ø29</i>	602
	Profilgleiter ZN 40 x 80 Loslager (Set)	<i>Profile Slider ZN 40 x 80 Loose Bearing (Set)</i>	584		Rolle ø39	<i>Roller ø39</i>	603
	Profilgleiter ZN 40 x 80 Festlager (Set)	<i>Profile Slider ZN 40 x 80 Fixed Bearing (Set)</i>	585		Rolle ø47	<i>Roller ø47</i>	604
	Profilgleiter ZN 40 x 80 mit Klemmhebel (Set)	<i>Profile Slider ZN 40 x 80 with Clamp Lever (Set)</i>	586		Rolle ø58	<i>Roller ø58</i>	605
	Profilgleiter ZN 40 x 80 Loslager mit Klemmhebel (Set)	<i>Profile Slider ZN 40 x 80 Loose Bearing w. Clamp Lever (Set)</i>	587		Laufwagen (Set)	<i>Trolley (Set)</i>	606
	Profilgleiter ZN 40 x 80 Festlager mit Klemmhebel (Set)	<i>Profile Slider ZN 40 x 80 Fixed Bearing w. Clamp Lever (Set)</i>	588				
	Profilgleiter ZN 40 x 80 mit Exzenterhebel (Set)	<i>Profile Slider ZN 40 x 80 with Cam Lever (Set)</i>	589				
	Profilgleiter ZN 40 x 80 Loslager m. Exzenterhebel (Set)	<i>Profile Slider ZN 40 x 80 Loose Bearing w. Cam Lever (Set)</i>	590				
	Profilgleiter ZN 40 x 80 Festlager m. Exzenterhebel (Set)	<i>Profile Slider ZN 40 x 80 Fixed Bearing w. Cam Lever (Set)</i>	591				
	Profilgleiter flach	<i>Profile Slider Flat</i>	592				
	Profilgleiter Steg mittig 10	<i>Profile Slider Center Ridge 10</i>	593				
	Profilgleiter Nut mittig	<i>Profile Slider Center Slot</i>	594				
	Profilgleiter 8+10	<i>Profile Glide 8+10</i>	595				
	Set Hubtür-Führung	<i>Set Lift Door Guide</i>	596				
	Falttürelement (Set)	<i>Folding Door Element (Set)</i>	597				
	Set Schiebetür-Führung	<i>Set Sliding Door Guide</i>	598				
	Schiebetür-Führungssatz	<i>Sliding Door Guide Set</i>	599				
	Flächengleiter	<i>Panel Slider</i>	600				
	Rolle ø19	<i>Roller ø19</i>	601				



PROFILGLEITER ZN 40 × 80 (SET)

PROFILE SLIDER ZN 40 × 80 (SET)

Ausführung	Nut 8	Model	Slot 8
Beschreibung	zur gleitenden Führung von Profilen mit Nut 8, mit beiliegenden Sechskantmuttern M6 zur Befestigung von Anbauelementen	Description	To guide slidingly profiles with slot 8, delivered with hexagon nuts M6 for the fixation of add-on elements
Material	Gleitschlitten: Zinkdruckguss Gleitschuh: Kunststoff POM Befestigung: Stahl	Material	Sliding carriage: Zinc die-cast Slide shoe: Plastic POM Fixation: Steel
Farbe	Gleitschuh: natur	Color	Slide shoe: Natural
Set	1 Gleitschlitten, 2 Gleitschuhe, 2 Sechskantmuttern DIN 439 B - M6	Set	1 sliding carriage, 2 slide shoes, 2 hexagon nuts DIN 439 B - M6
Liefereinheit	10 Stück	Pack Quantity	10 pieces
Hinweis	passende Profilgleiter ZN 40 × 80 Sets inkl. Befestigungssatz für Loslager und Festlager siehe Seite 584 und Seite 585	Tip	Compatible profile sliders ZN 40 × 80 sets with assembly set for loose bearing and fixed bearing see page 584 and page 585

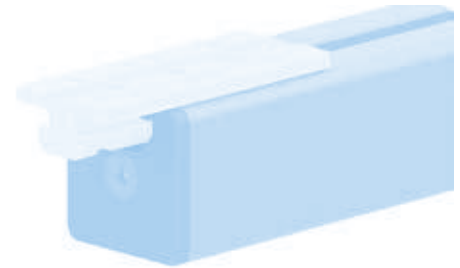
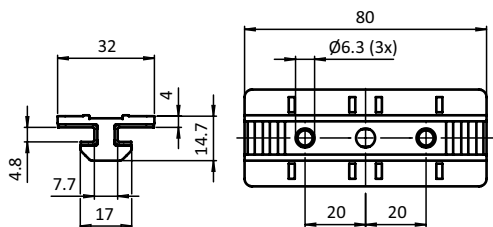

Profilgleiter ZN 40 × 80 (Set)
Profile Slider ZN 40 × 80 (Set)

Gewicht [g]
Weight [g]

Profil
Profile

Teil-Nr.
Part #

77.0

I

093PS0840

Gleiter und Rollen *Sliders and Rollers*

Profilgleiter *Profile Sliders*

Profilgleiter ZN *Profile Sliders ZN*



PROFILGLEITER ZN 40 × 80 LOSLAGER (SET)

PROFILE SLIDER ZN 40 × 80 LOOSE BEARING (SET)

<p>Ausführung Nut 8</p> <p>Beschreibung zur gleitenden Führung von Profilen mit Nut 8, Loslager*</p> <p>Material Gleitschlitten: Zinkdruckguss Gleitschuh: Kunststoff POM Befestigung: Stahl O-Ring: EPDM</p> <p>Farbe Gleitschuh: natur O-Ring: schwarz</p> <p>Set 1 Gleitschlitten, 2 Gleitschuhe, 2 Linsenkopfschrauben ISO 7380 - M5 × 25, 2 O-Ringe DIN 3771 - 5 × 1,5, 2 Nutzensteine - Nut 8 - M5</p> <p>Liefereinheit 10 Stück</p> <p>Hinweis * Profilführungen mit mehreren Profilgleitern ZN 40 × 80 müssen als Kombination aus Festlager (F) und Loslager (L) ausgeführt werden; hierdurch werden Formtoleranzen ausgeglichen und eine leichte Beweglichkeit sichergestellt.; Passender Profilgleiter ZN 40 × 80 Festlager siehe Seite 585</p>	<p>Model Slot 8</p> <p>Description To guide slidingly profiles with slot 8, loose bearing*</p> <p>Material Sliding carriage: Zinc die-cast Slide shoe: Plastic POM Fixation: Steel O-ring: EPDM</p> <p>Color Slide shoe: Natural O-ring: Black</p> <p>Set 1 sliding carriage, 2 slide shoes, 2 button head screws ISO 7380 - M5 × 25, 2 O-rings DIN 3771 - 5 × 1.5, 2 T-slot nuts - slot 8 - M5</p> <p>Pack Quantity 10 pieces</p> <p>Tip * Profile tracks with several profile slides ZN 40 × 80 need to be executed as a combination of a loose bearing (L) and a fixed bearing (F); this way, shape tolerances can be compensated and easy movability is provided.; compatible profile slider ZN 40 × 80 fixed bearing see page 585</p>
--	---

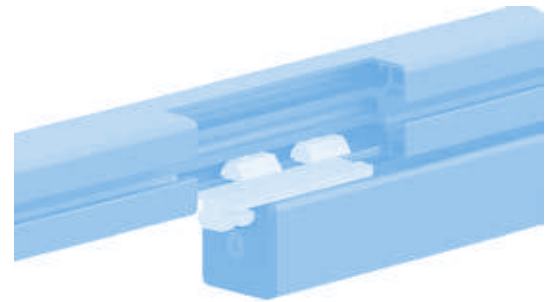
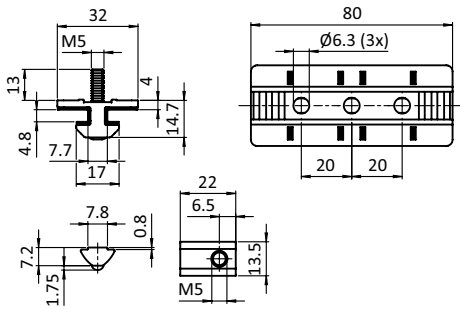

Profilgleiter ZN 40 × 80 (Set)
Profile Slider ZN 40 × 80 (Set)

Gewicht [g]
Weight [g]

Profil
Profile

Teil-Nr.
Part #

Loslager <i>Loose bearing</i>	101.0	I	093PS0840L
-------------------------------	-------	---	------------

7

Gleiter und Rollen *Sliders and Rollers*

Profilgleiter *Profile Sliders*

Profilgleiter ZN *Profile Sliders ZN*



PROFILGLEITER ZN 40 × 80 FESTLAGER (SET)

PROFILE SLIDER ZN 40 × 80 FIXED BEARING (SET)

Ausführung	Nut 8	Model	Slot 8
Beschreibung	zur gleitenden Führung von Profilen mit Nut 8, Festlager*	Description	To guide slidingly profiles with slot 8, fixed bearing*
Material	Gleitschlitten: Zinkdruckguss Gleitschuh: Kunststoff POM Befestigung: Stahl O-Ring: EPDM	Material	Sliding carriage: Zinc die-cast Slide shoe: Plastic POM Fixation: Steel O-ring: EPDM
Farbe	Gleitschuh: natur O-Ring: schwarz	Color	Slide shoe: Natural O-ring: Black
Set	1 Gleitschlitten, 2 Gleitschuhe, 2 Linsenkopfschrauben ISO 7380 - M6 × 25, 2 O-Ringe DIN 3771 - 5 × 1,5, 2 Nutensteine - Nut 8 - M6	Set	1 sliding carriage, 2 slide shoes, 2 button head screws ISO 7380 - M6 × 25, 2 O-rings DIN 3771 - 5 × 1.5, 2 T-slot nuts - slot 8 - M6
Liefereinheit	10 Stück	Pack Quantity	10 pieces
Hinweis	* Profilführungen mit mehreren Profilgleitern ZN 40 × 80 müssen als Kombination aus Festlager (F) und Loslager (L) ausgeführt werden; hierdurch werden Formtoleranzen ausgeglichen und eine leichte Beweglichkeit sichergestellt; Passender Profilgleiter ZN 40 × 80 Loslager siehe Seite 584	Tip	* Profile tracks with several profile sliders ZN 40 × 80 need to be executed as a combination of a loose bearing (L) and a fixed bearing (F); this way, shape tolerances can be compensated and easy movability is provided; compatible profile slider ZN 40 × 80 loose bearing see page 584

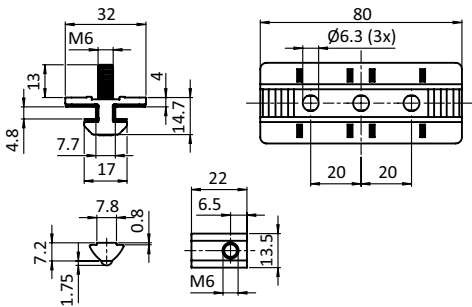

Profilgleiter ZN 40 × 80 (Set) Profile Slider ZN 40 × 80 (Set)	Gewicht [g] Weight [g]	Profil Profile	Teil-Nr. Part #
Festlager <i>Fixed bearing</i>	105.0	I	093PS0840F

Gleiter und Rollen *Sliders and Rollers*

Profilgleiter *Profile Sliders*

Profilgleiter ZN *Profile Sliders ZN*



PROFILGLEITER ZN 40 × 80 MIT KLEMMHEBEL (SET)

PROFILE SLIDER ZN 40 × 80 WITH CLAMP LEVER (SET)

<p>Ausführung Nut 8</p> <p>Beschreibung zur gleitenden Führung von Profilen mit Nut 8; zusätzliche Klemmung des Schlittens erweitert die Einsatzmöglichkeiten, z. B. als verstellbarer Endanschlag; Haltekraft bei maximalem Anzugsmoment (15 Nm) 600 N; mit beiliegenden Sechskantmuttern M6 zur Befestigung von Anbauelementen</p> <p>Material Gleitschlitten: Zinkdruckguss Gleitschuh: Kunststoff POM Befestigung: Stahl Klemmhebel: Kunststoff, glasfaserverstärkt Klemmhebel-Mechanik: Stahl</p> <p>Farbe Gleitschuh: natur Klemmhebel: schwarz</p> <p>Set 1 Gleitschlitten, 2 Gleitschuhe, 1 Klemmhebel mit Aussengewinde M6 × 55*, 1 Sonder-Nutenstein - Nut 8 - M6 , 1 Scheibe DIN 9021 6,4 mm, 2 Sechskantmuttern DIN 439 B - M6</p> <p>Liefereinheit 10 Stück</p> <p>Hinweis * Verwendung des Klemmhebels M6: Profil 40 mm + Profil 40 mm, Gewindelänge: 55 mm; Ablängen des Klemmhebels M6, z.B.: Profil 40 mm + Profil 20 mm, Gewinde ablängen auf: 35 mm Profil 40 mm + Flächenelement 10 mm, Gewinde ablängen auf: 25 mm</p>	<p>Model Slot 8</p> <p>Description To guide slidingly profiles with slot 8; the additional clamping feature for the slide carriage extends the range of applications, e.g as adjustable end stop; retention force at maximum tightening torque(15 Nm) 600 N; including hexagon nuts M6 for the attachment of additional components</p> <p>Material Sliding carriage: Zinc die-cast Slide shoe: Plastic POM Fixation: Steel Clamp lever handle: Plastic, glass fiber reinforced Clamp lever mechanics: Steel:</p> <p>Color Slide shoe: Natural Clamp lever handle: Black</p> <p>Set 1 sliding carriage, 2 slide shoes, 1 clamp lever with external thread M6 × 55*, 1 special T-slot nut - slot 8 - M6, 1 shim DIN 9021 6.4 mm, 2 hexagon nuts DIN 439 B - M6</p> <p>Pack Quantity 10 pieces</p> <p>Tip * Use of the M6 clamp lever: 40 mm profile + 40 mm profile, thread length: 55 mm Cut to length of the M6 clamp lever, e.g.: 40 mm profile + 20 mm profile, cut thread length to: 35 mm 40 mm profile + 10 mm panel, cut thread length to: 25 mm</p>
--	---

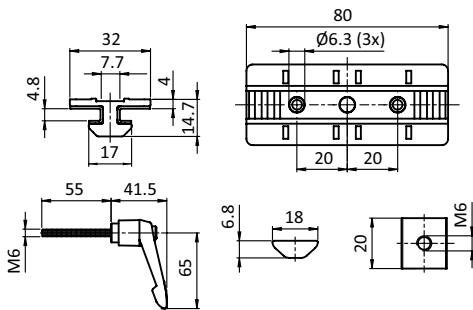

Profilgleiter ZN 40 × 80 (Set) Profile Slider ZN 40 × 80 (Set)	Gewicht [g] Weight [g]	Profil Profile	Teil-Nr. Part #
mit Klemmhebel <i>With clamp lever</i>	136.0	I	093PS0840S01



PROFILGLEITER ZN 40 × 80 L MIT KLEMMHEBEL (SET)

PROFILE SLIDER ZN 40 × 80 L WITH CLAMP LEVER (SET)

<p>Ausführung Nut 8</p> <p>Beschreibung zur gleitenden Führung von Profilen mit Nut 8, Loslager*; zusätzliche Klemmung des Schlittens erhöht die Einsatzmöglichkeiten, z. B. als verstellbarer Endanschlag; Haltekraft bei maximalem Anzugsmoment (15 Nm) 600 N</p> <p>Material Gleitschlitten: Zinkdruckguss Gleitschuh: Kunststoff POM Befestigung: Stahl Klemmhebel: Kunststoff, glasfaserverstärkt Klemmhebel-Mechanik: Stahl O-Ring: EPDM</p> <p>Farbe Gleitschuh: natur Klemmhebel: schwarz O-Ring: schwarz</p> <p>Set 1 Gleitschlitten, 2 Gleitschuhe, 1 Klemmhebel mit Aussengewinde M6 × 55**, 1 Sonder-Nutenstein - Nut 8 - M6, 1 Scheibe DIN 9021 6,4 mm, 2 Linsenkopfschrauben ISO 7380 - M5 × 25, 2 O-Ringe DIN 3771 - 5 × 1,5, 2 Nutenteine - Nut 8 - M5</p> <p>Liefereinheit 10 Stück</p> <p>Hinweis * Profilführungen mit mehreren Profilgleitern ZN 40 × 80 müssen als Kombination aus Festlager (F) und Loslager (L) ausgeführt werden; hierdurch werden Formtoleranzen ausgeglichen und eine leichte Beweglichkeit sichergestellt; passender Profilgleiter ZN 40 × 80 Festlager siehe Seite 585; Festlager mit Klemmhebel siehe Seite 588</p>	<p>Model Slot 8</p> <p>Description To guide slidingly profiles with slot 8, loose bearing*, the additional clamping feature for the slide carriage extends the range of applications, e.g as adjustable end stop; retention force at maximum tightening torque (15 Nm) 600 N</p> <p>Material Sliding carriage: Zinc die-cast Slide shoe: Plastic POM Fixation: Steel Clamp lever handle: Plastic, glass fiber reinforced Clamp lever mechanics: Steel O-ring: EPDM</p> <p>Color Slide shoe: Natural Clamp lever handle: Black O-ring: Black</p> <p>Set 1 sliding carriage, 2 slide shoes, 1 clamp lever with external thread M6 × 55**, 1 special T-slot nut - slot 8 - M6, 1 shim DIN 9021 6.4 mm, 2 button head screws ISO 7380 - M5 × 25, 2 O-rings DIN 3771 - 5 × 1.5, 2 T-slot nuts - slot 8 - M5</p> <p>Pack Quantity 10 pieces</p> <p>Tip * Profile tracks with several profile slides ZN 40 × 80 need to be executed as a combination of a loose bearing (L) and a fixed bearing (F); this way, shape tolerances can be compensated and easy movability is provided; compatible profile slider ZN 40 × 80 loose bearing see page 585; fixed bearing with clamp lever see page 588</p>
---	--

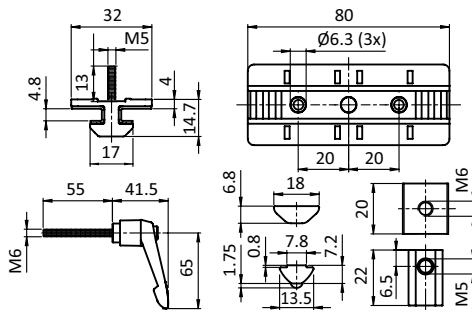

Profilgleiter ZN 40 × 80 (Set) Profile Slider ZN 40 × 80 (Set)	Gewicht [g] Weight [g]	Profil Profile	Teil-Nr. Part #
Loslager mit Klemmhebel <i>Loose bearing with clamp lever</i>	160.0	I	093PS0840LS01



PROFILGLEITER ZN 40 × 80 F MIT KLEMMHEBEL (SET)

PROFILE SLIDER ZN 40 × 80 F WITH CLAMP LEVER (SET)

<p>Ausführung Nut 8</p> <p>Beschreibung zur gleitenden Führung von Profilen mit Nut 8, Festlager*; zusätzliche Klemmung des Schlittens erhöht die Einsatzmöglichkeiten, z. B. als verstellbarer Endanschlag; Haltekraft bei maximalem Anzugsmoment (15 Nm) 600 N</p> <p>Material Gleitschlitten: Zinkdruckguss Gleitschuh: Kunststoff POM Befestigung: Stahl Klemmhebel: Kunststoff, glasfaserverstärkt Klemmhebel-Mechanik: Stahl O-Ring: EPDM:</p> <p>Farbe Gleitschuh: natur Klemmhebel: schwarz O-Ring: schwarz</p> <p>Set 1 Gleitschlitten, 2 Gleitschuhe, 1 Klemmhebel mit Aussengewinde M6 × 55**, 1 Sonder-Nutenstein - Nut 8 - M6, 1 Scheibe DIN 9021 6,4 mm, 2 Linsenkopfschrauben ISO 7380 - M6 × 25, 2 O-Ringe DIN 3771 - 5 × 1,5, 2 Nutenteine - Nut 8 - M6</p> <p>Liefereinheit 10 Stück</p> <p>Hinweis * Profilführungen mit mehreren Profilgleitern ZN 40 × 80 müssen als Kombination aus Festlager (F) und Loslager (L) ausgeführt werden; hierdurch werden Formtoleranzen ausgeglichen und eine leichte Beweglichkeit sichergestellt; passender Profilgleiter ZN 40 × 80 Loslager siehe Seite 584, Loslager mit Klemmhebel siehe Seite 587</p>	<p>Model Slot 8</p> <p>Description To guide slidingly profiles with slot 8, fixed bearing*; the additional clamping feature for the slide carriage extends the range of applications, e.g as adjustable end stop; retention force at maximum tightening torque (15 Nm) 600 N</p> <p>Material Sliding carriage: Zinc die-cast Slide shoe: Plastic POM Fixation: Steel Clamp lever handle: Plastic, glass fiber reinforced Clamp lever mechanics: Steel O-ring: EPDM:</p> <p>Color Slide shoe: Natural Clamp lever handle: Black O-ring: Black</p> <p>Set 1 sliding carriage, 2 slide shoes, 1 clamp lever with external thread M6 × 55**, 1 special T-slot nut - slot 8 - M6, 1 shim DIN 9021 6.4 mm, 2 button head screws ISO 7380 - M6 × 25, 2 O-rings DIN 3771 - 5 × 1.5, 2 T-slot nuts - slot 8 - M6</p> <p>Pack Quantity 10 pieces</p> <p>Tip * Profile tracks with several profile slides ZN 40 × 80 need to be executed as a combination of a loose bearing (L) and a fixed bearing (F); this way, shape tolerances can be compensated and easy movability is provided; compatible profile slider ZN 40 × 80 loose bearing see page 584, loose bearing with clamp lever see page 587</p>
---	---

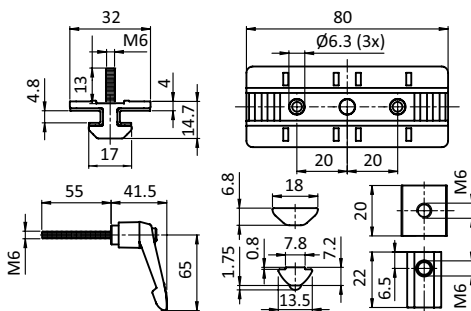

Profilgleiter ZN 40 × 80 (Set) Profile Slider ZN 40 × 80 (Set)	Gewicht [g] Weight [g]	Profil Profile	Teil-Nr. Part #
Festlager mit Klemmhebel <i>Fixed bearing with clamp lever</i>	164.0	I	093PS0840FS01



PROFILGLEITER ZN 40 × 80 MIT EXZENTERHEBEL (SET) PROFILE SLIDER ZN 40 × 80 WITH CAM LEVER (SET)

<p>Ausführung Nut 8</p> <p>Beschreibung zur gleitenden Führung von Profilen mit Nut 8; zusätzliche Klemmung des Schlittens erhöht die Einsatzmöglichkeiten, z. B. als schnell verstellbarer Endanschlag; mit beiliegenden Sechskantmuttern M6 zur Befestigung von Anbauelementen</p> <p>Material Gleitschlitten: Zinkdruckguss Gleitschuh: Kunststoff POM Befestigung: Stahl Exzenterhebel: Kunststoff, glasfaserverstärkt Exzenterhebel-Mechanik: Stahl</p> <p>Farbe Gleitschuh: natur Exzenterhebel: schwarz</p> <p>Set 1 Gleitschlitten, 2 Gleitschuhe, 1 Exzenterhebel mit Aussengewinde M6 × 55*, 1 Sonder-Nutenstein - Nut 8 - M6, 2 Sechskantmuttern DIN 439 B - M6</p> <p>Liefereinheit 10 Stück</p> <p>Hinweis * Verwendung des Exzenterhebels M6: Profil 40 mm + Profil 40 mm, Gewindelänge: 55 mm Ablängen des Exzenterhebels M6, z.B.: Profil 40 mm + Profil 20 mm, Gewinde ablängen auf: 35 mm Profil 40 mm + Flächenelement 10 mm, Gewinde ablängen auf: 25 mm</p>	<p>Model Slot 8</p> <p>Description To guide slidingly profiles with slot 8, the additional clamping feature for the slide carriage extends the range of applications, e.g as quickly adjustable end stop; including hexagon nuts M6 for the attachment of additional components</p> <p>Material Sliding carriage: Zinc die-cast Slide shoe: Plastic POM Fixation: Steel Cam lever handle: Plastic, glass fiber reinforced Cam lever mechanics: Steel</p> <p>Color Slide shoe: Natural Cam lever handle: Black</p> <p>Set 1 sliding carriage, 2 slide shoes, 1 cam lever with external thread M6 × 55*, 1 special T-slot nut - slot 8 - M6, 2 hexagon nuts DIN 439 B - M6</p> <p>Pack Quantity 10 pieces</p> <p>Tip * Use of the M6 cam lever: 40 mm profile + 40 mm profile, thread length: 55 mm Cut to length of the M6 cam lever, e.g.: 40 mm profile + 20 mm profile, cut thread length to: 35 mm 40 mm profile + 10 mm panel, cut thread length to: 25 mm</p>
---	---

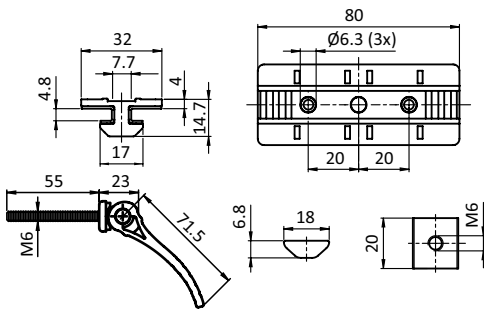

Profilgleiter ZN 40 × 80 (Set)
Profile Slider ZN 40 × 80 (Set)

mit Exzenterhebel <i>Witch cam lever</i>	Gewicht [g] Weight [g]	Profil Profile	Teil-Nr. Part #
	127.0	I	093PS0840S02



PROFILGLEITER ZN 40 × 80 L MIT EXZENTERHEBEL (SET) PROFILE SLIDER ZN 40 × 80 L WITH CAM LEVER (SET)

<p>Ausführung Nut 8</p> <p>Beschreibung zur gleitenden Führung von Profilen mit Nut 8, Loslager*; zusätzliche Klemmung des Schlittens erhöht die Einsatzmöglichkeiten, z. B. als schnell verstellbarer Endanschlag</p> <p>Material Gleitschlitten: Zinkdruckguss Gleitschuh: Kunststoff POM Befestigung: Stahl Exzenterhebel: Kunststoff, glasfaserverstärkt Exzenterhebel-Mechanik: Stahl O-Ring: EPDM</p> <p>Farbe Gleitschuh: natur Exzenterhebel: schwarz O-Ring: schwarz</p> <p>Set 1 Gleitschlitten, 2 Gleitschuhe, 1 Exzenterhebel mit Aussengewinde M6 × 55**, 1 Sonder-Nutenstein - Nut 8 - M6, 2 Linsenkopfschrauben ISO 7380 - M5 × 25, 2 O-Ringe DIN 3771 - 5 × 1,5, 2 Nutenteine - Nut 8 - M5</p> <p>Liefereinheit 10 Stück</p> <p>Hinweis * Profilführungen mit mehreren Profilgleitern ZN 40 × 80 müssen als Kombination aus Festlager (F) und Loslager (L) ausgeführt werden; hierdurch werden Formtoleranzen ausgeglichen und eine leichte Beweglichkeit sichergestellt; passender Profilgleiter ZN 40 × 80 Festlager siehe Seite 585; Festlager mit Exzenterhebel siehe Seite 591</p>	<p>Model Slot 8</p> <p>Description To guide slidingly profiles with slot 8, loose bearing*; the additional clamping feature for the slide carriage extends the range of applications, e.g as quickly adjustable end stop</p> <p>Material Sliding carriage: Zinc die-cast Slide shoe: Plastic POM Fixation: Steel Cam lever handle: Plastic, glass fiber reinforced Cam lever mechanics: Steel O-ring: EPDM</p> <p>Color Slide shoe: Natural Cam lever handle: Black O-ring: Black</p> <p>Set 1 sliding carriage, 2 slide shoes, 1 cam lever with external thread M6 × 55**, 1 special T-slot nut - slot 8 - M6, 2 button head screws ISO 7380 - M5 × 25, 2 O-rings DIN 3771 - 5 × 1.5, 2 T-slot nuts - slot 8 - M5</p> <p>Pack Quantity 10 pieces</p> <p>Tip * Profile tracks with several profile slides ZN 40 × 80 need to be executed as a combination of a loose bearing (L) and a fixed bearing (F); this way, shape tolerances can be compensated and easy movability is provided; compatible profile slider ZN 40 × 80 fixed bearing see page 585; fixed bearing with cam lever see page 591</p>
--	--

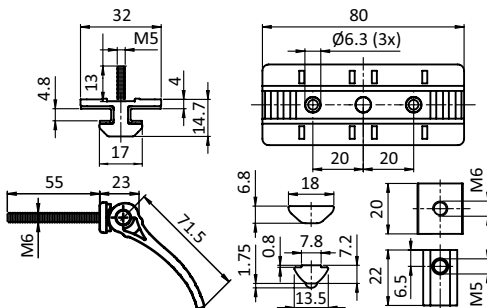

Profilgleiter ZN 40 × 80 (Set)
Profile Slider ZN 40 × 80 (Set)

Gewicht [g]
Weight [g]

Profil
Profile

Teil-Nr.
Part #

Loslager mit Exzenterhebel <i>Loose bearing with cam lever</i>	151.0	I	093PS0840LS02
--	-------	---	---------------



PROFILGLEITER ZN 40 × 80 F MIT EXZENTERHEBEL (SET) PROFILE SLIDER ZN 40 × 80 F WITH CAM LEVER (SET)

<p>Ausführung Nut 8</p> <p>Beschreibung zur gleitenden Führung von Profilen mit Nut 8, Festlager*; zusätzliche Klemmung des Schlittens erhöht die Einsatzmöglichkeiten, z. B. als schnell verstellbarer Endanschlag</p> <p>Material Gleitschlitten: Zinkdruckguss Gleitschuh: Kunststoff POM Befestigung: Stahl Exzenterhebel: Kunststoff, glasfaserverstärkt Exzenterhebel-Mechanik: Stahl O-Ring: EPDM</p> <p>Farbe Gleitschuh: natur Exzenterhebel: schwarz O-Ring: schwarz</p> <p>Set 1 Gleitschlitten, 2 Gleitschuhe, 1 Exzenterhebel mit Aussengewinde M6 × 55**, 1 Sonder-Nutenstein - Nut 8 - M6, 2 Linsenkopfschrauben ISO 7380 - M6 × 25, 2 O-Ringe DIN 3771 - 5 × 1,5, 2 Nutenteine - Nut 8 - M6</p> <p>Liefereinheit 10 Stück</p> <p>Hinweis * Profilführungen mit mehreren Profilgleitern ZN 40 × 80 müssen als Kombination aus Festlager (F) und Loslager (L) ausgeführt werden; hierdurch werden Formtoleranzen ausgeglichen und eine leichte Beweglichkeit sichergestellt; passender Profilgleiter ZN 40 × 80 Loslager siehe Seite 584; Loslager mit Exzenterhebel siehe Seite 590</p>	<p>Model Slot 8</p> <p>Description To guide slidingly profiles with slot 8, fixed bearing*, the additional clamping feature for the slide carriage extends the range of applications, e.g as quickly adjustable end stop</p> <p>Material Sliding carriage: Zinc die-cast Slide shoe: Plastic POM Fixation: Steel Cam lever handle: Plastic, glass fiber reinforced Cam lever mechanics: Steel O-ring: EPDM</p> <p>Color Slide shoe: Natural Cam lever handle: Black O-ring: Black</p> <p>Set 1 sliding carriage, 2 slide shoes, 1 cam lever with external thread M6 × 55**, 1 special T-slot nut - slot 8 - M6, 2 button head screws ISO 7380 - M6 × 25, 2 O-rings DIN 3771 - 5 × 1.5, 2 T-slot nuts - slot 8 - M6</p> <p>Pack Quantity 10 pieces</p> <p>Tip * Profile tracks with several profile slides ZN 40 × 80 need to be executed as a combination of a loose bearing (L) and a fixed bearing (F); this way, shape tolerances can be compensated and easy movability is provided; compatible profile slider ZN 40 × 80 loose bearing see page 584; loose bearing with cam lever see page 590</p>
---	--

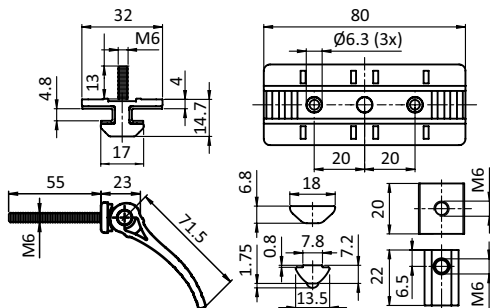

Profilgleiter ZN 40 × 80 (Set) Profile Slider ZN 40 × 80 (Set)	Gewicht [g] Weight [g]	Profil Profile	Teil-Nr. Part #
Festlager mit Exzenterhebel <i>Fixed bearing with cam lever</i>	155.0	I	093PS0840FS02

Gleiter und Rollen *Sliders and Rollers*

Profilgleiter *Profile Sliders*

Profilgleiter *Profile Sliders*



PROFILGLEITER FLACH

PROFILE SLIDER FLATS

Ausführung	Nut 6, 8, 10	Model	Slot 6, 8, 10
Beschreibung	zur gleitenden Führung von Profilen mit Nuten; ökonomische und verschleißarme Lösung, z. B. für Flächenelemente	Description	To guide slidingly profiles with slot; economic and wear-resistant solution, e.g. for panels
Material	Kunststoff POM	Material	Plastic POM
Befestigung	mit Blechschrauben	Fastening	With sheet-metal screws
Liefereinheit	10 Stück	Pack Quantity	10 pieces

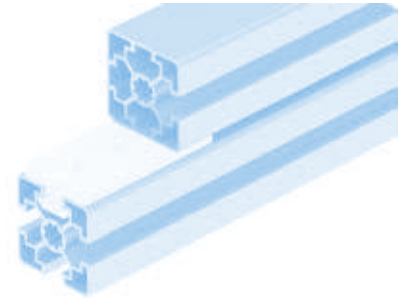
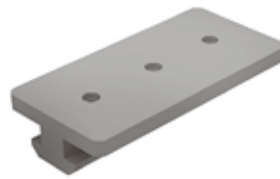
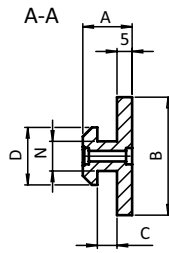
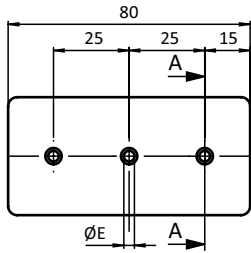

Profilgleiter flach Profile Slider Flat	A [mm]	B [mm]	C [mm]	D [mm]	E [mm]	N	Gewicht [g] Weight [g]	Profil Profile	Teil-Nr. Part #
	9.8	17.0	2.3	11.5	2.8	6	13.0	B	093SM06S02
	11.5	26.0	3.0	15.0	2.8	8	22.0	B	093SM08S02
	16.3	39.0	6.5	19.0	3.5	10	37.0	B	093SM10S02

7

Gleiter und Rollen *Sliders and Rollers*

Profilgleiter *Profile Sliders*

Profilgleiter *Profile Sliders*



PROFILGLEITER STEG MITTIG 10

PROFILE SLIDER CENTER RIDGE 10

Ausführung	Nut 10	Model	Slot 10
Beschreibung	zur gleitenden Führung von Profilen mit Nut 10; ökonomische und verschleißarme Lösung, z. B. für Schiebetüren	Description	To guide slidingly profiles with slot 10; economic and wear-resistant solution, e.g. for sliding doors
Material	Kunststoff POM	Material	Plastic POM
Befestigung	mit Blechschrauben	Fastening	With sheet-metal screws
Liefereinheit	10 Stück	Pack Quantity	10 pieces

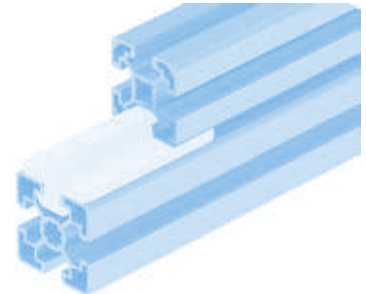
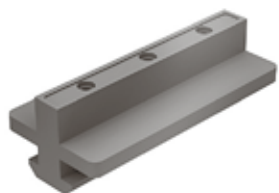
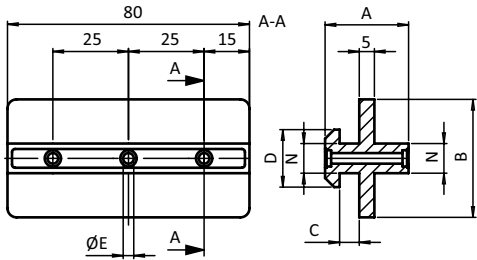

Profilgleiter Nut mittig <i>Profile Slider Center Slot</i>	A [mm]	B [mm]	C [mm]	D [mm]	E [mm]	N	Gewicht [g] <i>Weight [g]</i>	Profil <i>Profile</i>	Teil-Nr. <i>Part #</i>
	27.6	39.0	6.5	19.0	3.5	10	48.0	B	093SM10S01

Gleiter und Rollen *Sliders and Rollers*

Profilgleiter *Profile Sliders*

Profilgleiter *Profile Sliders*



PROFILGLEITER NUT MITTIG

PROFILE SLIDER CENTER SLOT

Ausführung	Nut 8, 10	Model	Slot 8, 10
Beschreibung	zur gleitenden Führung von Profilen mit Nut 8 oder Nut 10; ökonomische und verschleißarme Lösung, z. B. für Schiebetüren	Description	To guide slidingly profiles with slot; economic and wear-resistant solution, e.g. for sliding doors
Material	Kunststoff POM	Material	Plastic POM
Befestigung	mit Blechschrauben	Fastening	With sheet-metal screws
Liefereinheit	10 Stück	Pack Quantity	10 pieces

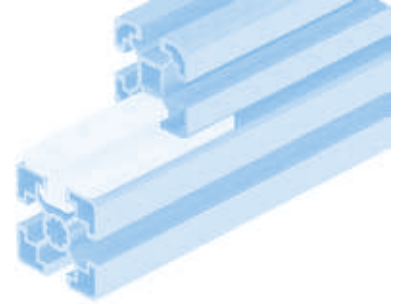
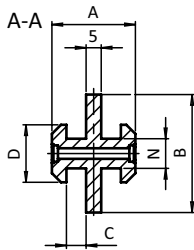
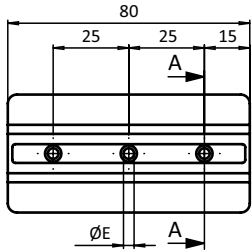

Profilgleiter Nut mittig Profile Slider Center Slot	A [mm]	B [mm]	C [mm]	D [mm]	E [mm]	N	Gewicht [g] Weight [g]	Profil Profile	Teil-Nr. Part #
	18.0	26.0	3.0	15.0	2.8	8	29.0	B	093SM08
	27.6	39.0	6.5	19.0	3.5	10	53.0	B	093SM10

7

Gleiter und Rollen *Sliders and Rollers*

Profilgleiter *Profile Sliders*

Profilgleiter *Profile Sliders*



PROFILGLEITER 8+10

PROFILE GLIDE 8+10

Ausführung	Nut 8+10	Model	Slot 8+10
Beschreibung	zur gleitenden Führung von Profilen mit Nut 8 und Nut 10, auch kombinierbar; ökonomische und verschleißarme Lösung, z. B. für Schiebetüren	Description	To guide slidingly profiles with slots 8 and 10, also combinable; economical and wear-resistant solution, for example for sliding doors
Material	Kunststoff POM	Material	Plastic POM
Farbe	natur	Color	Natural
Befestigung	Nut 8 mit DIN 914 (ISO 4028) - M8 × 12 Nut 10 mit DIN 914 (ISO 4028) - M8 × 20	Fastening	Slot 8 with DIN 914 (ISO 4028), M8 × 12 Slot 10 with DIN 914 (ISO 4028), M8 × 20
Liefereinheit	10 Stück	Pack Quantity	10 pieces

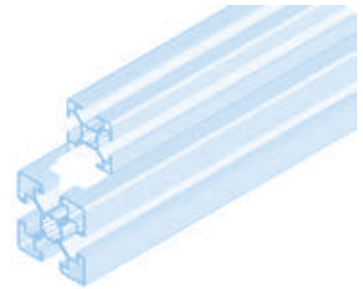
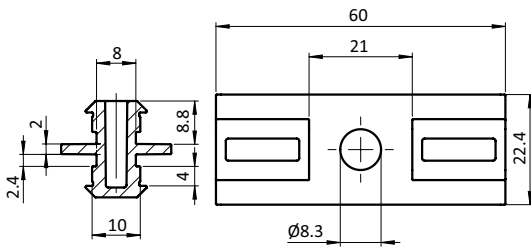

Profilgleiter Profile Glide	N	Gewicht [g] Weight [g]	Profil Profile	Teil-Nr. Part #
	8 / 10	9.0	B	093SM0810

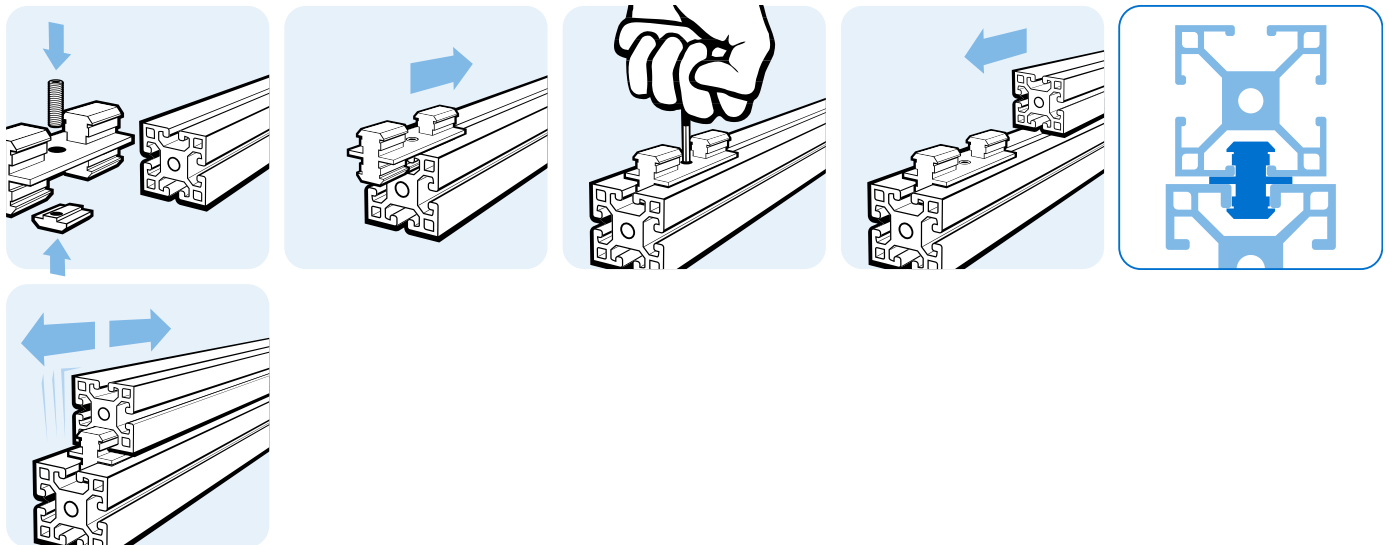

SET HUBTÜR-FÜHRUNG

SET LIFT DOOR GUIDE

<p>Ausführung Kunststoff POM</p> <p>Beschreibung zur Montage von Hubtüren mit 25 mm breitem PUR-Zahnriemen DIN 7721 T10 (nicht im Lieferumfang enthalten)</p> <p>Material Gehäuse: Kunststoff POM Montageset: Stahl</p> <p>Farbe Gehäuse: schwarz</p> <p>Set 1 Gehäuse, 2-teilig, 1 Einlegeblech, 1 Schraube ISO 7380 - M6 x 25, 3 Sechskantmuttern DIN 934 - M6, 3 Schrauben DIN 912 - M6 x 25, 1 Nutenstein - Nut 8 - M 6</p> <p>Liefereinheit 10 Stück</p>	<p>Model Plastic POM</p> <p>Description To assemble sliding doors with 25 mm width PUR toothed belt DIN 7721 T10 (not included in delivery)</p> <p>Material Housing: Plastic POM Assembly set: Steel</p> <p>Color Housing: Black</p> <p>Set 1 two-part housing, 1 inlay sheet, 1 screw ISO 7380 - M6 x 25, 3 hexagon nuts DIN 934 - M6, 3 screws DIN 912 - M6 x 25, 1 T-slot nuts - Nut 8 - M 6</p> <p>Pack Quantity 10 pieces</p>
---	--

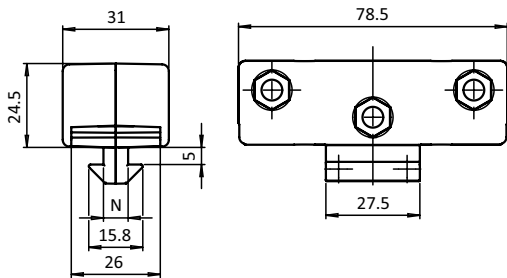

Set Hubtür-Führung Set Lift Door Guide	N	Gewicht [g] Weight [g]	Profil Profile	Teil-Nr. Part #
	8	97.0	I	093087S01

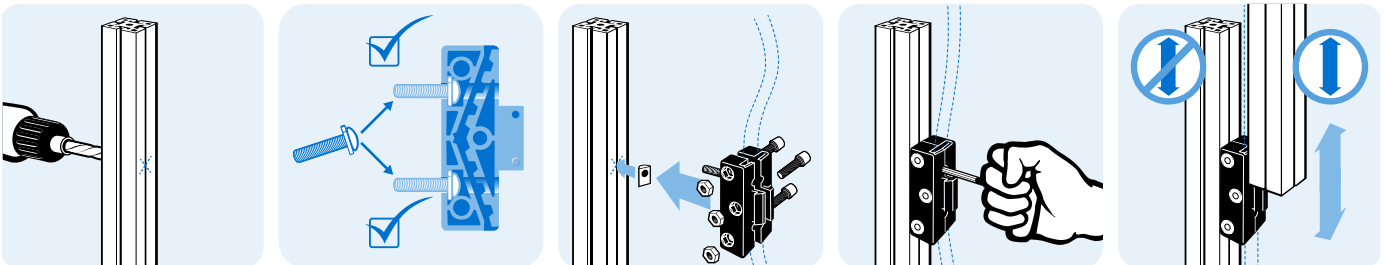

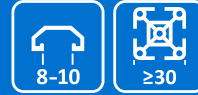

FALTTÜRELEMENT (SET)

FOLDING DOOR ELEMENT (SET)

<p>Ausführung Aluminium</p> <p>Beschreibung zur Montage von Falttüren mit gleichzeitiger Dreh- und Gleitbewegung; Führungsbuchse für Nut 8 oder Nut 10 in unterschiedlichen Positionen einsteckbar; hochwertige Ausführung</p> <p>Material Falttürelement: Aluminium Schrauben: Stahl Hammermuttern: Stahl Zylinderstift: Stahl Führungsbuchsen: POM</p> <p>Farbe Führungsbuchsen: schwarz</p> <p>Set 1 Falttürelement, 2 Schrauben DIN 7991 - M5 × 10, 2 Hammermuttern - Nut 8 - M5, 1 Zylinderstift ISO 2338 - D5 × 14, 1 Führungsbuchse - Nut 8, 1 Führungsbuchse - Nut 10</p> <p>Liefereinheit 10 Stück</p> <p>Extras weitere Oberflächen auf Anfrage</p>	<p>Model Aluminum</p> <p>Description To assemble folding doors, simultaneous turning and sliding movement; guide bush can be inserted in different positions for slot 8 and 10; high quality design</p> <p>Material Folding door element: Aluminum Screws: Steel Hammer nuts: Steel Pin: Steel Guide bushes: POM</p> <p>Color Guide bushes: Black</p> <p>Set 1 folding door element, 2 screws DIN 7991 - M5 × 10, 2 hammer nuts - slot 8 - M5, 1 pin ISO 2338 - D5 × 14, 1 guide bush - slot 8, 1 guide bush - slot 10</p> <p>Pack Quantity 10 pieces</p> <p>Specials Other surfaces on request</p>
--	--

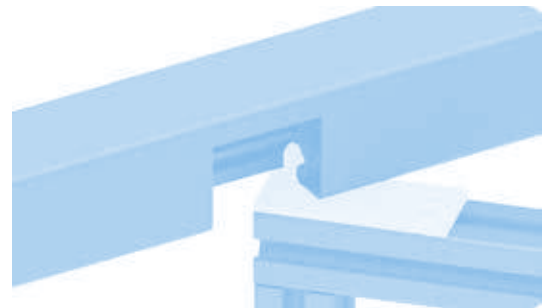
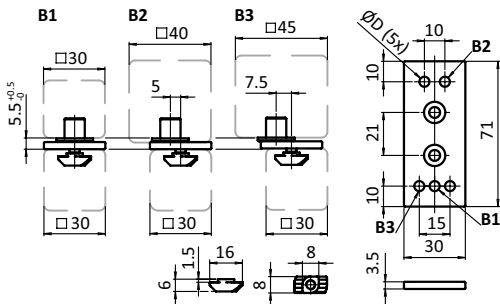

Falttürelement (Set) Folding Door Element (Set)	ØD [mm]	Gewicht [g] Weight [g]	Profil Profile	Teil-Nr. Part #
	4.9	147.9	B	093FDE30N0810

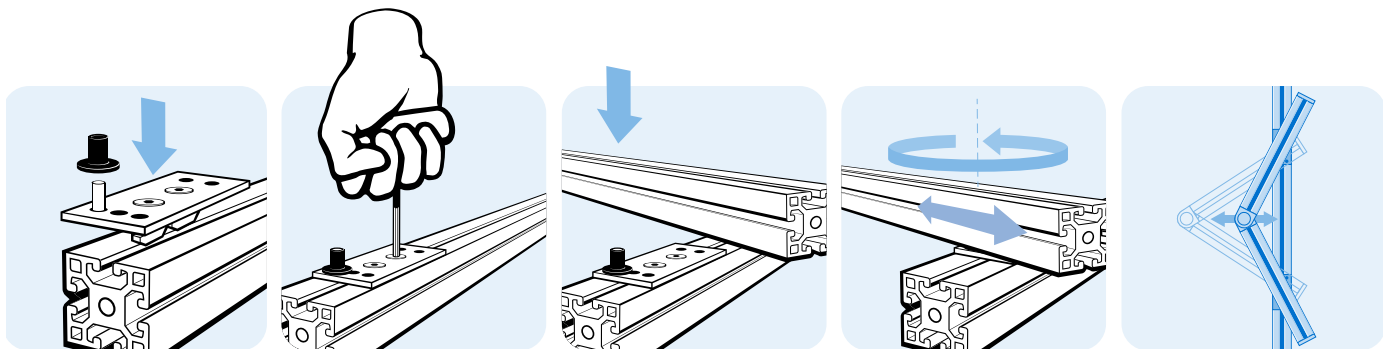



SET SCHIEBETÜR-FÜHRUNG

SET SLIDING DOOR GUIDE

Ausführung	Kunststoff POM	Model	Plastic POM
Beschreibung	zur Montage von Schiebetüren	Description	To assemble sliding doors
Max. Gewicht Tür	10 kg	Max. weight door	10 kg
Material	Schiebetür-Führung: Kunststoff POM Mechanik: Stahl, verzinkt	Material	Sliding door guide: Plastic POM Mechanism: Zinc plated steel
Liefereinheit	10 × 1 Stück	Pack Quantity	10 × 1 pieces
Liefereinheit Set	10 × 4 Stück	Pack Quantity Set	10 × 4 pieces

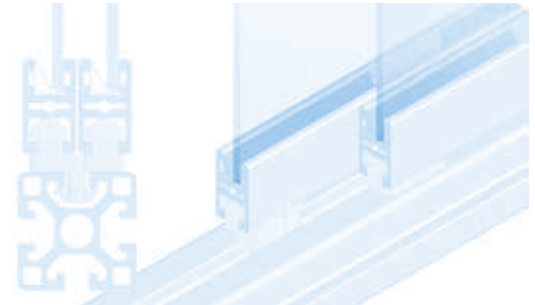
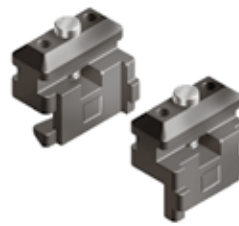
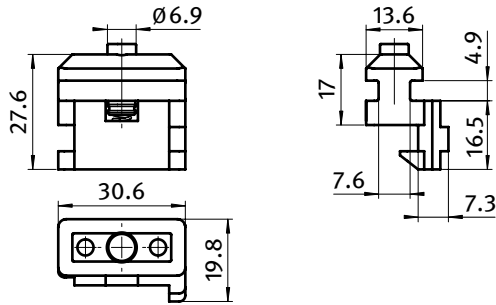

Set Schiebetür-Führung Set Sliding Door Guides	N	Gewicht [g] Weight [g]	Profil Profile	Teil-Nr. Part #
(L) linke Ausführung (L) Left side version	8	11.0	I	093084L
(R) rechte Ausführung (R) Right side version	8	11.0	I	093084R
Set	8	44.0	I	093084S01

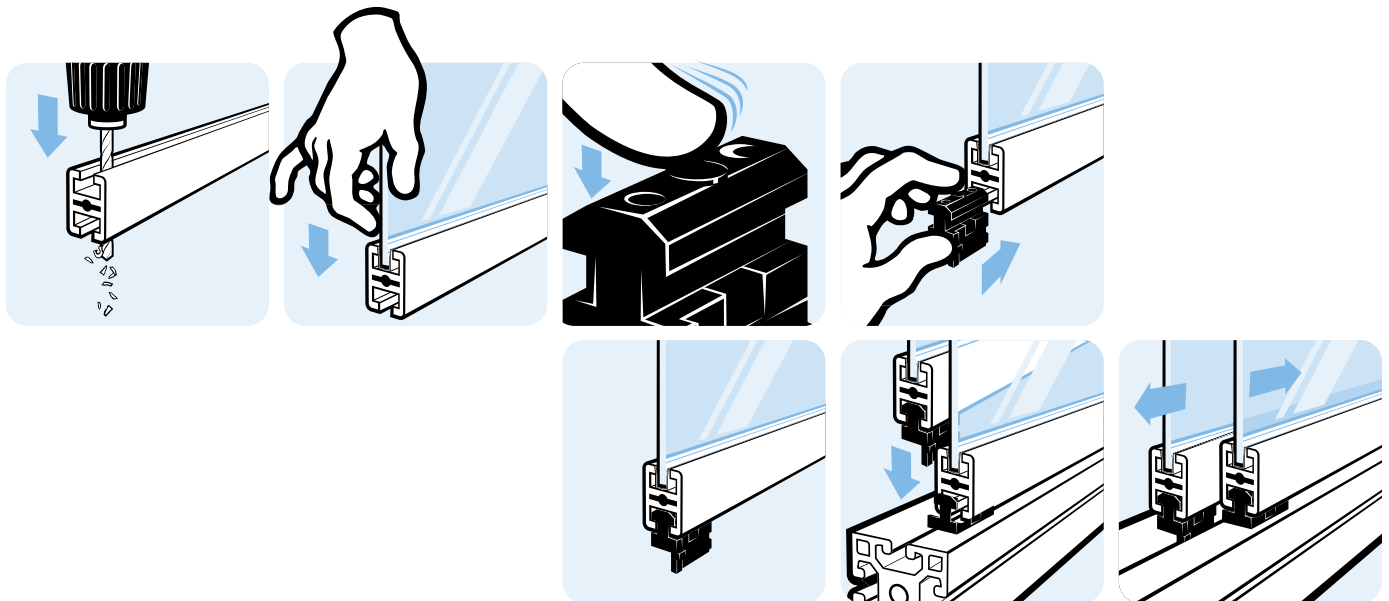



SCHIEBETÜR-FÜHRUNGSSATZ

SLIDING DOOR GUIDE SET

Ausführung	Nut 8 - 10	Model	Slot 8 - 10
Beschreibung	zur rechtwinkligen Verbindung von zwei Aluminiumprofilen und zur Führung von Hub- oder Schiebetüren in der Nut des Aluminiumprofils, mit Kugellager; Distanzscheiben können gewechselt werden: für 2 mm Abstand zu feststehendem Element oder 2 bzw. 4 mm Abstand zu parallelem Roll-Element	Description	To connect two aluminum profiles at right angles and to guide lift or sliding doors in the slot of an aluminum profile, with ball bearing; spacers can be changed: for a 2 mm distance between door and fixed profile or a 2 or 4 mm distance between two doors
Material	Gehäuse: Aluminiumdruckguss Rolle: Kunststoff PA, glaskugelverstärkt Distanzscheibe: Kunststoff PA, glasfaserverstärkt	Material	Casing: Aluminum die-cast Roller: Plastic PA, glass ball reinforced Spacer: Plastic PA, glass fiber reinforced
Farbe	Rolle: schwarz Distanzscheibe: natur	Color	Roller: Black Spacer: Natural
Set	1 Gehäuse, 1 Rolle, 1 Schraube als Achse, 3 Distanzscheiben	Set	1 casing, 1 roller, 1 screw as axle, 3 spacers
Liefereinheit	10 Stück	Pack Quantity	10 pieces



Schiebetür-Führungssatz <i>Sliding Door Guide Set</i>	B [mm]	N	Gewicht [g] <i>Weight [g]</i>	Profil <i>Profile</i>	Teil-Nr. <i>Part #</i>
	40	8	137.0		093095
	40	10	175.0	B	093097
	45	10	230.0	B	093098

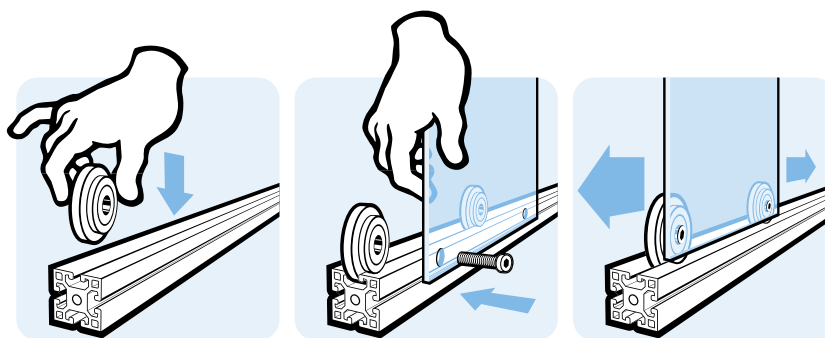



FLÄCHENGLEITER

PANEL SLIDER

Ausführung	Nut 10	Model	Slot 10
Beschreibung	zur Führung von Flächenelementen als Hub- oder Schiebetür in der Nut des Aluminiumprofils	Description	To guide guide lift or sliding doors in the slot of an aluminum profile
Material	Kunststoff POM	Material	Plastic POM
Farbe	schwarz	Color	Black
Liefereinheit	10 Stück	Pack Quantity	10 pieces

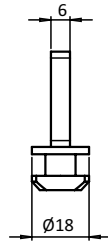
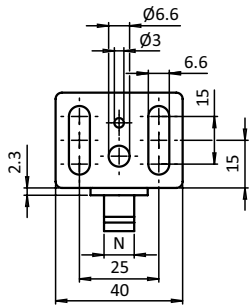

Flächengleiter <i>Panel Slider</i>	N	Gewicht [g] <i>Weight [g]</i>	Profil <i>Profile</i>	Teil-Nr. <i>Part #</i>
	10	9.0	B	093SN10

Gleiter und Rollen *Sliders and Rollers*

Rollen *Rollers*

Rollen *Rollers*



ROLLE Ø19

ROLLER Ø19

Ausführung	Kunststoff PA, Nut 5	Model	Plastic PA, slot 5
Beschreibung	zur Führung von bewegten Teilen in der Nut des Aluminiumprofils	Description	To guide moving parts in the slot of the aluminum profile
Material	Rolle: Kunststoff PA, glaskugelverstärkt Buchse: Stahl, verzinkt Scheibe: Stahl, verzinkt	Material	Roller: Plastic PA, glass ball reinforced Bush: Steel, zinc plated Washer: Steel, zinc plated
Farbe	schwarz	Color	Black
Liefereinheit	10 Stück	Pack Quantity	10 pieces
Extras	☁ elektrostatisch entladend, weitere Farben auf Anfrage	Specials	☁ electrostatically discharging, other colors on request

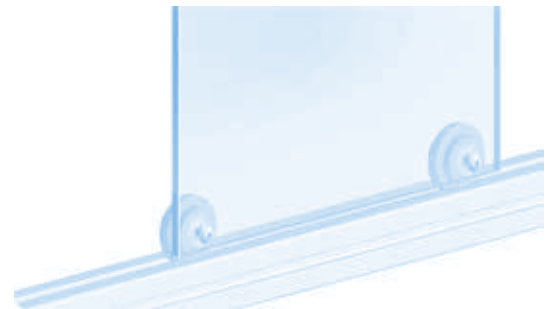
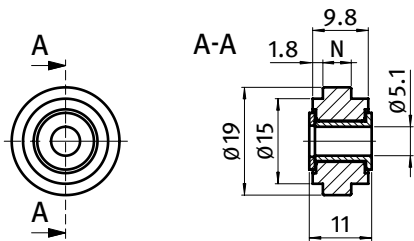

Rolle ø19
Roller ø19

N

Gewicht [g]
Weight [g]

Teil-Nr.
Part #

5

4.2

093028

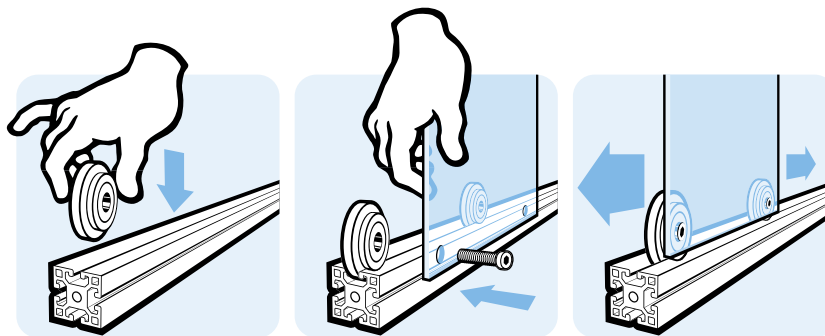



ROLLE Ø29

ROLLER Ø29

Ausführung	Kunststoff PA, Nut 6	Model	Plastic PA, slot 6
Beschreibung	zur Führung von bewegten Teilen in der Nut des Aluminiumprofils	Description	To guide moving parts in the slot of the aluminum profile
Material	Rolle: Kunststoff PA, glaskugelverstärkt Buchse: Stahl, verzinkt Scheibe: Stahl, verzinkt	Material	Roller: Plastic PA, glass ball reinforced Bush: Steel, zinc plated Washer: Steel, zinc plated
Farbe	schwarz	Color	Black
Liefereinheit	10 Stück	Pack Quantity	10 pieces
Extras	⚡ elektrostatisch entladend, weitere Farben auf Anfrage	Specials	⚡ electrostatically discharging, other colors on request

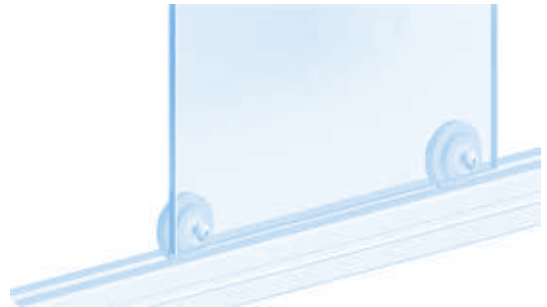
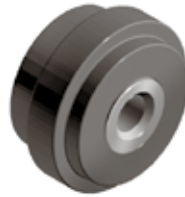
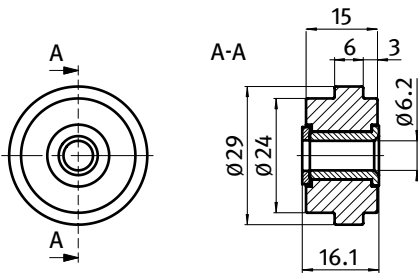

Rolle ø29 Roller ø29	N	Gewicht [g] Weight [g]	Teil-Nr. Part #
	6	8.5	093029

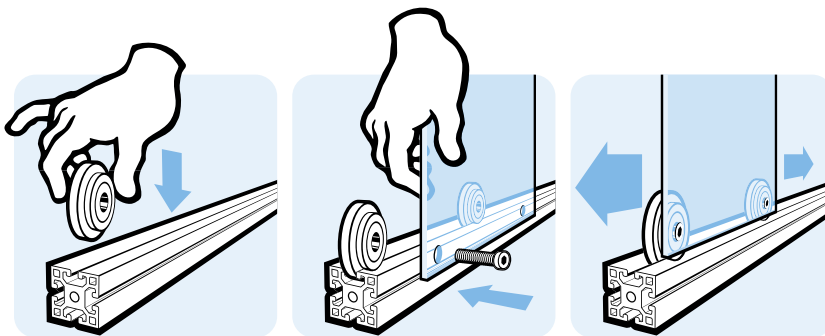

7



ROLLE Ø39

ROLLER Ø39

Ausführung	Kunststoff PA, Nut 8, 10, 12	Model	Plastic PA, slot 8, 10, 12
Beschreibung	zur Führung von bewegten Teilen in der Nut des Aluminiumprofils, mit Kugellager	Description	To guide moving parts in the slot of the aluminum profile, with ball bearing
Material	Kunststoff PA, glaskugelverstärkt	Material	Plastic PA, glass ball reinforced
Farbe	schwarz	Color	Black
Liefereinheit	10 Stück	Pack Quantity	10 pieces
Extras	☁ elektrostatisch entladend, weitere Farben auf Anfrage	Specials	☁ electrostatically discharging, other colors on request

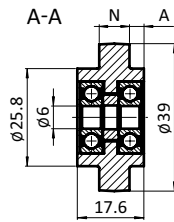
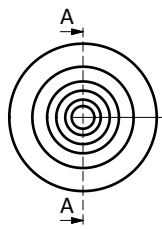

Rolle Ø39 Roller Ø39	A [mm]	N	Gewicht [g] Weight [g]	Teil-Nr. Part #
	3.8	8	30.0	093020
	3.8	10	31.8	093021
	2.8	12	33.2	093022

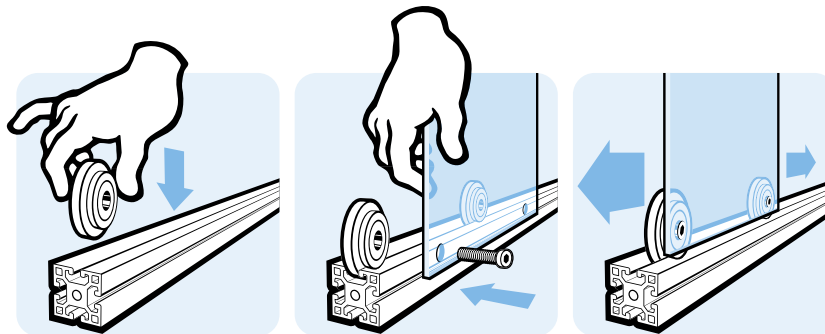

Gleiter und Rollen *Sliders and Rollers*

Rollen *Rollers*

Rollen *Rollers*



ROLLE Ø47

ROLLER Ø47

Ausführung	Kunststoff PA, Nut 8, 10	Model	Plastic PA, slot 8, 10
Beschreibung	zur Führung von bewegten Teilen in der Nut des Aluminiumprofils, mit Kugellager	Description	To guide moving parts in the slot of the aluminum profile, with ball bearing
Material	Kunststoff PA, glaskugelverstärkt	Material	Plastic PA, glass ball reinforced
Farbe	schwarz	Color	Black
Liefereinheit	10 Stück	Pack Quantity	10 pieces
Extras	☁ elektrostatisch entladend, weitere Farben auf Anfrage	Specials	☁ electrostatically discharging, other colors on request

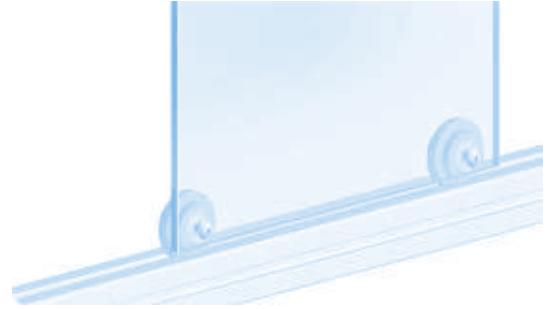
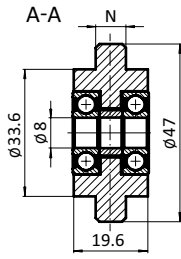
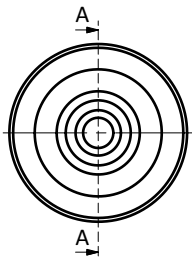

Rolle ø47
Roller ø47

N

Gewicht [g]
Weight [g]

Teil-Nr.
Part #

8

48.3

093024

10

50.0

093025

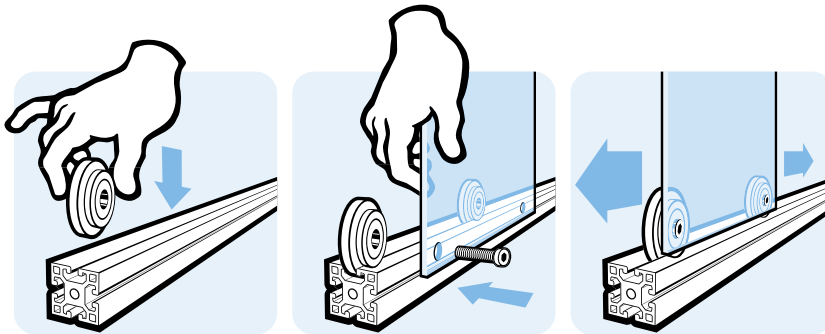

7



ROLLE Ø58

ROLLER Ø58

Ausführung	Kunststoff PA, Nut 10	Model	Plastic PA, slot 10
Beschreibung	zur Führung von bewegten Teilen in der Nut des Aluminiumprofils, mit Kugellager	Description	To guide moving parts in the slot of the aluminum profile, with ball bearing
Material	Kunststoff PA, glaskugelverstärkt	Material	Plastic PA, glass ball reinforced
Farbe	schwarz	Color	Black
Set	1 Rolle, 1 Hammermutter Nut 10 M8, Stahl verzinkt, 1 Zylinderschraube DIN 7984 M8 × 40, Stahl verzinkt, 1 Scheibe DIN 7349	Set	1 roller, 1 hammer nut, slot 10 M8, zinc-plated steel, 1 cylinder head screw DIN 7984 M8 × 40, zinc-plated steel, 1 washer DIN 7349
Liefereinheit	10 Stück	Pack Quantity	10 pieces
Extras	🌀 elektrostatisch entladend, weitere Farben auf Anfrage	Specials	🌀 electrostatically discharging, other colors on request



Rolle ø58 Roller ø58		N	Gewicht [g] Weight [g]	Teil-Nr. Part #
Set		10	154.5	093026

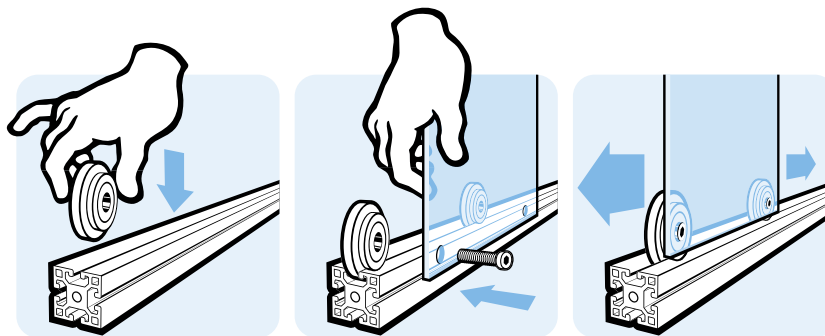



LAUFWAGEN (SET)

TROLLEY (SET)

Ausführung	vormontiert	Model	Pre-assembled
Beschreibung	zur beweglichen Aufhängung von Schiebetüren aus Profil Nut 8 in Profilschiene Nut 10	Description	For moving suspended sliding doors built of slot 8 profiles in slot 10 rail profile
Material	Laufwagen: Kunststoff PA Kugellager: Stahl Zylinderstift: Edelstahl Befestigungsmaterial: Stahl	Material	Trolley: Plastic PA Bearing: Steel Straight pin: Stainless steel Mounting material: Steel
Farbe	Laufwagen: schwarz	Color	Trolley: Black
Oberfläche	Kugellager: verchromt (RoHS-konform) Zylinderstift: blank Befestigungsmaterial: verzinkt	Surface	Bearing: Chrome plated (RoHS compliant) Cylinder pin: Plain Mounting material: Zinc plated
Liefereinheit	1 Set	Pack Quantity	1 set
Set	1 Laufwagen mit 2 montierten Kugellagern, 1 Zylinderstift DIN 7 - Ø 8 × 20, 2 Schrauben DIN 912 - M5 × 30, 2 Scheiben 5-FSt, 2 Hammermuttern - Nut 8 - M5	Set	1 trolley with 2 mounted bearings 1 cylinder pin DIN 7 - Ø 8 × 20, 2 screws DIN 912 - M5 × 30, 2 washers 5-FSt, 2 hammer head nuts - slot 8 - M5

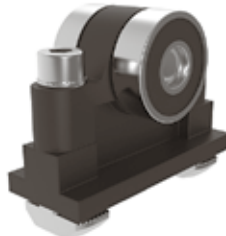
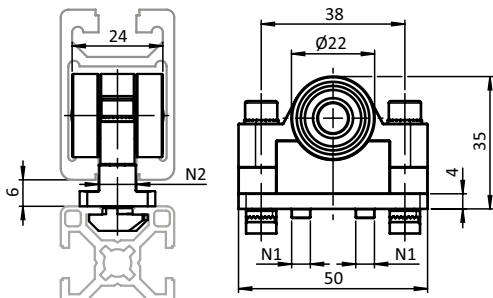

Laufwagen (Set)
Trolley (Set)

Gewicht [g]
Weight [g]

Profil
Profile

Teil-Nr.
Part #

71.0







































B





093101

INHALTSÜBERSICHT *CONTENT OVERVIEW*



Bodenelemente <i>Floor Elements</i>	1
Scharniere <i>Hinges</i>	2
Nutmuttern und -schrauben <i>T-Nuts and T-Bolts</i>	3
Verbindungstechnik <i>Connecting Systems</i>	4
Griffe und Verschlüsse <i>Handles and Latches</i>	5
Arbeitsplatzkomponenten <i>Components for Work Stations</i>	6
Gleiter und Rollen <i>Sliders and Rollers</i>	7
Fördertechnik <i>Conveyors</i>	8
Schutz- und Trennwandelemente <i>Enclosures, Guards, Partitions</i>	9
Flächenbefestigungen <i>Panel Fasteners</i>	10
Abdeckelemente <i>Cover Elements</i>	11
Kabelführungen <i>Cable Management</i>	12
Diverse Komponenten <i>Miscellaneous Components</i>	13
Rundrohrkomponenten <i>Tubular Frame Components</i>	14

	Rollenelement, Clip-Fix	<i>Roller Element, Clip-Fix</i>	611		Bremse R28	<i>Brake R28</i>	633
	Rollenelement, schraubbar	<i>Roller Element, Screw-on Version</i>	612		Bremse H26	<i>Brake H26</i>	634
	Gleitleiste AL	<i>Slide Rail AL</i>	616		Rollenelement R9	<i>Roller Unit R9</i>	635
	Gleitrampe AL	<i>Transition Ramp AL</i>	617		Kugelelement	<i>Ball Unit</i>	636
	Gleitleiste	<i>Slide Rail</i>	618		Bürstenelement	<i>Brush Unit</i>	637
	Rollenschiene ST R28	<i>Roller Track ST R28</i>	619		Rolle R28	<i>Roller R28</i>	638
	Rollenschiene AL R28	<i>Roller Track AL R28</i>	620		Rolle H26	<i>Roller H26</i>	639
	Rollenschiene AL R28	<i>Roller Track AL R28</i>	621		Rolle R9	<i>Roller R9</i>	640
	Rollenschienen-Profil AL	<i>Roller Track Profile AL</i>	622		Achse für Rollenschienen AL	<i>Axle for AL Roller Tracks</i>	641
	Einhängelhalter AL D28	<i>Holding Bracket AL D28</i>	623		Käfig für Rollen R28	<i>Cage for Rollers R28</i>	642
	Variabler Halter AL D28	<i>Variable Holding Bracket AL D28</i>	624		Käfig für Rollen H26	<i>Cage for Rollers H26</i>	643
	Montagehalter AL D28	<i>Mounting Bracket AL D28</i>	625		Käfig für Rollen R9	<i>Cage for Rollers R9</i>	644
	Einhängelhalter ST D28	<i>Holding Bracket ST D28</i>	626		Distanzstück L25 für Rollenkäfig AL	<i>Spacer L25 for Roller Cage AL</i>	645
	Variabler Halter ST D28	<i>Variable Holding Bracket ST D28</i>	627		Kugeleinsatz D24	<i>Ball Insert D24</i>	646
	Montagehalter ST D28	<i>Mounting Bracket ST D28</i>	628		Bürsteneinsatz D24	<i>Brush Insert D24</i>	647
	Abschlussplatte AL	<i>End Plate AL</i>	629		Käfig für Kugel- / Bürsteneinsatz D24	<i>Cage for Ball / Brush Insert D24</i>	648
	Führungsschiene ST	<i>Guiding Rail ST</i>	630		Anschlagpuffer	<i>Stop Buffer</i>	649
	Führungsschiene ST	<i>Guiding Rail ST</i>	631		Anschlagpuffer	<i>Stop Buffer</i>	650
	Rollenelement L50 R28	<i>Roller Unit L50 R28</i>	632		Anschlagpuffer	<i>Buffer stop</i>	651

	Rollenhalter	<i>Roller Mounting Block</i>	652
	Sensorhalter	<i>Sensor Mounting Block</i>	653
	Set Rücklaufsperr	<i>Set Backlock</i>	654
	Rücklaufsperr	<i>Backstop Unit</i>	655
	Rücklaufsperr ST	<i>Backstop ST</i>	656



ROLLENELEMENT, CLIP-FIX

ROLLER ELEMENT, CLIP-FIX

Ausführung	Nut 8, 10	Model	Slot 8, 10
Beschreibung	zur Herstellung von Rollenbahnen in beliebiger Breite und Länge; schnelle, werkzeuglose Montage durch das Clip-Fix-System	Description	For manufacturing roller conveyors in any width and length; clip-fix system provides for quick assembly without any need for tools
Material	Gehäuse: Kunststoff PA, glaskugelverstärkt Rollen: Kunststoff POM	Material	Casing: Plastic PA, glass ball reinforced Rollers: Plastic POM
Farbe	schwarz	Color	Black
Befestigung	durch einfaches Eindrücken in die Nut, rastet sicher ein	Fastening	Secure fastening through simply inserting into slot
Liefereinheit	10 Stück	Pack Quantity	10 pieces

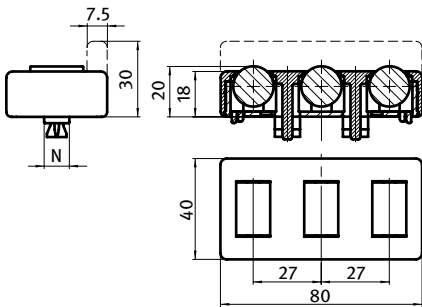

Rollenelement, Clip-Fix Roller Element, Clip-Fix	N	Gewicht [g] Weight [g]	Teil-Nr. Part #
ohne Seitenführung <i>Without lateral guide</i>	8-10	43.3	09309301
mit Seitenführung <i>With lateral guide</i>	8-10	48.0	09309303

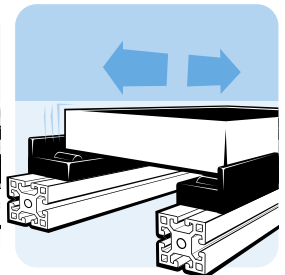
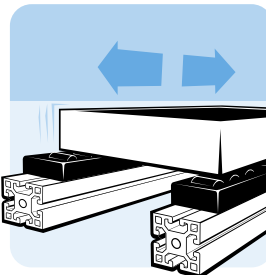
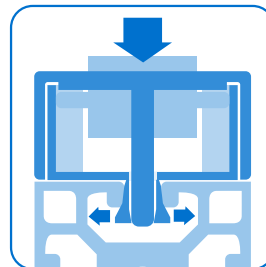
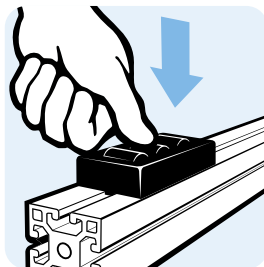
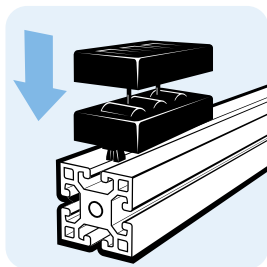
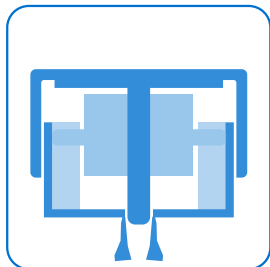

ROLLENELEMENT, SCHRAUBBAR

ROLLER ELEMENT, SCREW-ON VERSION

Ausführung	ohne Nut, Nut 8, Nut 10	Model	Without slot, slot 8, slot 10
Beschreibung	zur Herstellung von Rollenbahnen in beliebiger Breite und Länge, inkl. 2 Schrauben M5 × 25	Description	For manufacturing roller conveyors in any width and length, incl. 2 Screws M5 × 25
Material	Gehäuse: Kunststoff PA, glaskugelverstärkt Rollen: Kunststoff POM Montageset: Stahl	Material	Casing: Plastic PA, glass ball reinforced Rollers: Plastic POM Assembly set: Steel
Farbe	schwarz	Color	Black
Befestigung	Variante 1 (mit Klemmhammer): durch Einschrauben oder Einschlagen von 2 Schrauben M5 × 25 Variante 2 (ohne Klemmhammer): mit 2 Schrauben M5 × 25 und Nutensteinen oder Hammermuttern	Fastening	Version 1 (with clamp hammer): to be fastened with 2 screw-in or knock-in screws M5 × 25 Version 2 (without clamp hammer): using 2 screws M5 × 25 and T-slot nuts or hammer nuts
Montageset 2	2 Hammermuttern Nut 10 - M5	Assembly Set 2	2 hammer nuts lot 10 - M5
Liefereinheit	10 Stück	Pack Quantity	10 pieces
Hinweis	* elektrostatisch entladende Ausführung wird ohne Klemmhammer geliefert, zur Montage mit elektrostatisch entladenden Hammermuttern oder Nutensteinen	Tip	* delivery of electrostatically discharging version without clamp hammer, to fasten with electrostatically discharging hammer nuts or T-slot nuts

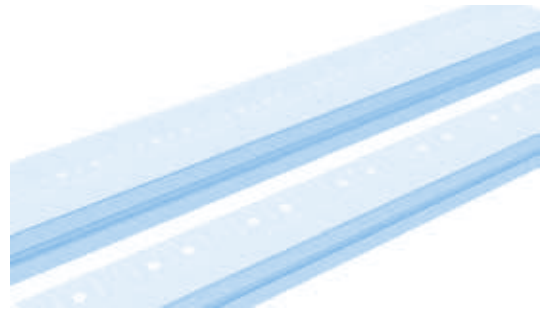
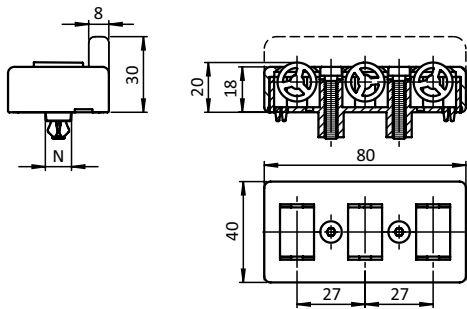

Rollenelement, schraubbar <i>Roller Element, Screw-on Version</i>	Montageset	N	ESD	Gewicht [g] <i>Weight [g]</i>	Profil <i>Profile</i>	Teil-Nr. <i>Part #</i>
ohne Seitenführung <i>Without lateral guide</i>	- / 8 / 10			53.0		09309302
	- / 8 / 10			54.5		* 09309302S01
inkl. Montageset 1 <i>With assembly set 1</i>		8		62.0	I	* 09309302S03
	inkl. Montageset 2 <i>With assembly set 2</i>	10		70.0	B	* 09309302S02
mit Seitenführung <i>With lateral guide</i>	- / 8 / 10			59.0		09309304
	- / 8 / 10			61.5		* 09309304S01
inkl. Montageset 1 <i>With assembly set 1</i>		8		69.0	I	* 09309304S04
	inkl. Montageset 2 <i>With assembly set 2</i>	10		77.0	B	* 09309304S03

ROLLENSCHIENEN

- FATH-Rollenschienensystem für Aluminium (AL) und Stahlprofil (ST)
- modularer Aufbau der Rollenbahnen für flexiblen Einsatz
- werkzeuglose Bestückung der Rollenschienen AL von oben
- verschiedene Rollengeometrien für jede Anwendung
- vier Farben und ESD-Ausführung lieferbar
- umfangreiches Zubehörprogramm

Rollenschienen für den manuellen Werkstücktransfer – mit FATH Komponenten!

FATH bietet ab sofort verschiedene Transporteinätze und Zubehör für Rollenprofile sowohl aus Aluminium als auch aus Stahl an. Die Bestückung des Aluprofils erfolgt ohne Werkzeug von oben. Wählen Sie zwischen Rollen-, Kugelrollen-, Bürsten- und Gleiteinsätzen. Die Elemente sind frei kombinierbar.

Für verschiedene Anwendungen gibt es verschiedene Rollengeometrien, je nachdem welche Anforderungen an Laufruhe, Rollenabstand und Belastung gestellt sind.

Die Rollen R28 mit Spurkranz bieten auch eine seitliche Führung.

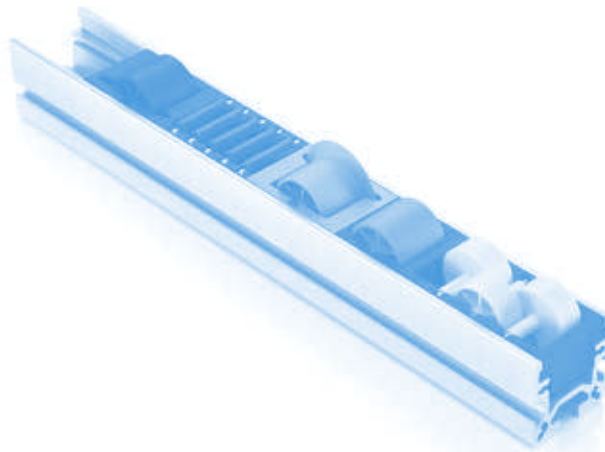

ROLLER TRACKS

- FATH roller track system for aluminum (AL) and steel (ST) profiles
- Modular system design for flexible application
- Mounting in the track profile AL without tools and from above
- Different roller shapes for any application
- Available in four colors and as ESD version
- Extensive accessories range

Roller Tracks for Manual Work Piece Transfer – built with FATH Components!

From now on, FATH offers a collection of different transport units and accessories for aluminum as well as steel roller track profiles. Assembly of the units in the aluminum profile can be done easily from above and without tools. You have the choice between different rollers, ball rollers, brush and slide units. All units can be freely combined.

There are different roller shapes for different applications, each designed to meet special requirements regarding running smoothness, center distance and load capacity.

Rollers R28 are also supplied with flange for lateral guidance.



Das Rollenelement R9 mit kürzestem Achsabstand und maximaler Achszahl wurde speziell für gleichmäßig verlaufende Transportstrecken mit minimalen Erschütterungen entwickelt. Dank der reduzierten Punktbelastung ist es besonders für sehr weiche Kartontagen und grob strukturierte Kistenböden geeignet.

The roller unit R9 has very small center distance and a maximum number of axles. It is designed to build tracks running smoothly with minimum vibrations. It provides a reduced point load on the good and is perfect for use with very soft cardboard boxes and coarsely built wooden boxes.



Auf Wunsch gibt es alle Elemente auch in elektrostatisch entladender Ausführung.

All units are available as electrostatically discharging version.





ROLLENSCHIENEN

ROLLER TRACKS

Über farbige Rollen sind Füllstandsmarken z.B. in Kanban-Regalen realisierbar.

With multi-colored rollers, level marks can be realized, e.g. for Kanban applications.



Kanban-Regal *Kanban Shelf*



Mobiles Kanban-Regal *Mobile Kanban Shelf*

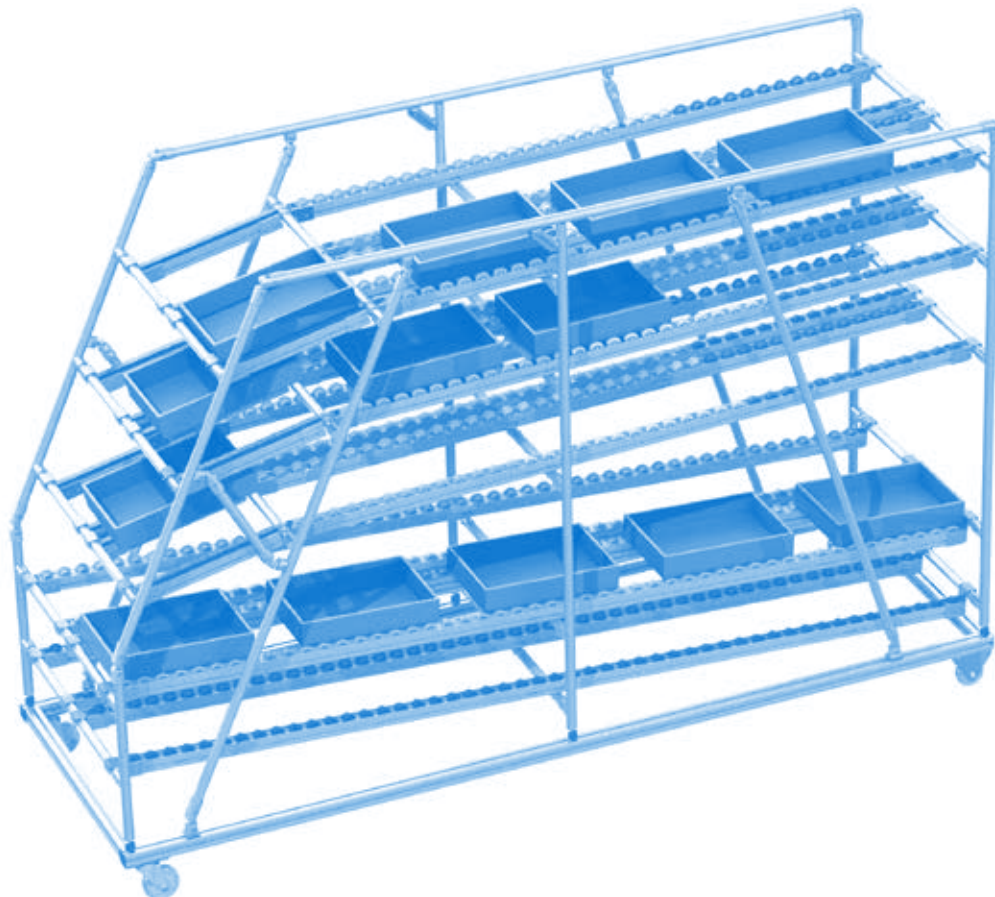

ROLLENSCHIENEN

Kugelrollen- und Bürsteneinsätze ermöglichen Bewegungen in zwei Dimensionen – auch quer zur Schienenrichtung, z.B. in Weichen oder Schleusen.

Abschlussplatten schließen die Enden der Rollenschiene AL sicher, sorgen für einen definierten Endanschlag und ermöglichen die Befestigung von Anschlagpuffern.



Die FATH-Rollen bestehen übrigens aus hochwertigem, glaskugelverstärktem Kunststoff PA.

ROLLER TRACKS

Ball roller and brush units provide for the possibility to move goods in two directions, even transversely to the track direction, e.g. at track switches and material locks.

End plates close the end face of the track profile safely, provide a defined end stop, and allow for the attachment of buffer stops.

By the way: FATH rollers are made from high-quality, glass ball reinforced Polyamide.



Passende Montagehalter in unterschiedlichen Ausführungen ermöglichen die Anbindung an Rundrohrprofile D28.

Compatible holding brackets in different versions connect with the tubular frame system D28.

Passende Halter siehe Seite	Compatible brackets see page	
Einhängelhalter AL D28 062AHD28M	Holding Bracket AL D28 062AHD28M	623
Variabler Halter AL D28 062AYMD28M	Variable Holding Bracket AL D28 062AYMD28M	624
Montagehalter AL D28 062AMD28M	Mounting Bracket AL D28 062AMD28M	625
Einhängelhalter ST D28 062MHD28M	Holding Bracket ST D28 062MHD28M	626
Variabler Halter ST D28 062MYMD28M	Variable Holding Bracket ST D28 062MYMD28M	627
Montagehalter ST D28 062MMD28M	Mounting Bracket ST D28 062MMD28M	628



Arbeitsplatz *Work Place*

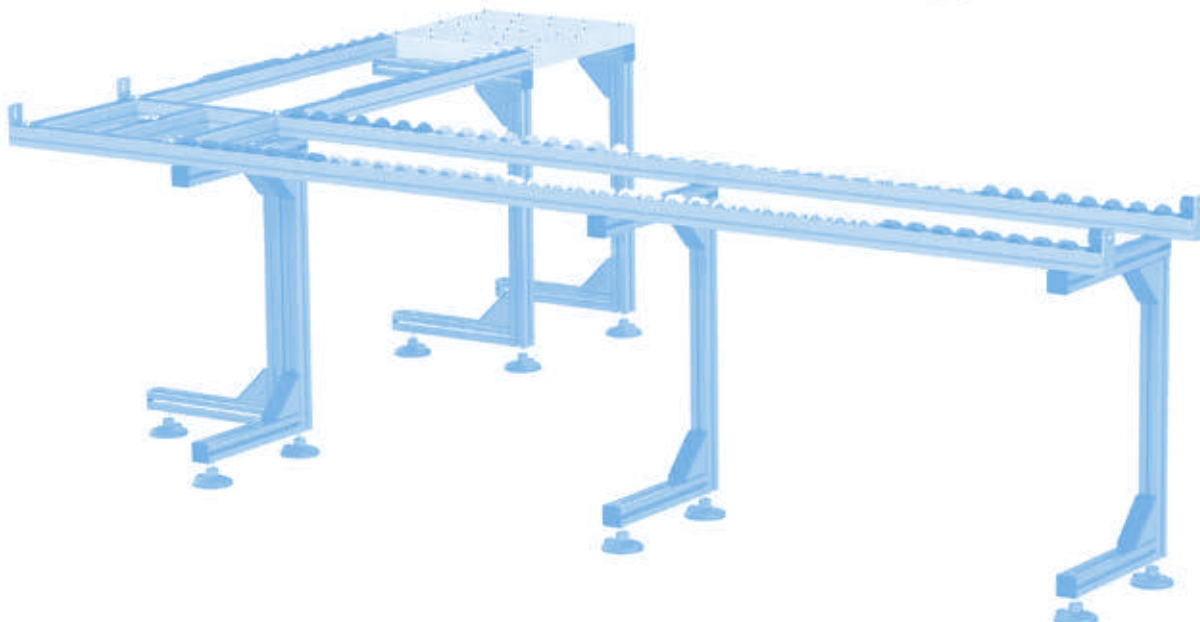



GLEITLEISTE AL

SLIDE RAIL AL

<p>Ausführung für Rollenschienen AL</p> <p>Beschreibung zum Einbau in zwei Höhenlagen, verschleißarme Gleitleiste für den einfachen Transport oder zum Einsatz bei starkem Gefälle, auch als Abdeckung und Distanzstück zwischen zwei Kugel- / Bürstenelementen geeignet</p> <p>Material Standard-Ausführung: Kunststoff PE-HD ⚡elektrostatisch entladende Ausführung: Kunststoff PE-HD, kohlefaserverstärkt</p> <p>Farbe schwarz</p> <p>Liefereinheit 20 Meter (10 Stück à 2 m)</p> <p>Extras weitere Längen, weitere Farben auf Anfrage</p>	<p>Model For roller tracks AL</p> <p>Description Can be installed in two positions to provide different levels; low-wear slide rail for simple transport or for use on steep slopes, also suitable as cover profile and spacer between two ball and brush units</p> <p>Material Standard version: Plastics PE-HD ⚡electrostatically discharging version: Plastics PE-HD, carbon fiber reinforced</p> <p>Color Black</p> <p>Pack Quantity 20 meter (10 pieces at 2 m)</p> <p>Specials Other lengths, other colors on request</p>
--	--

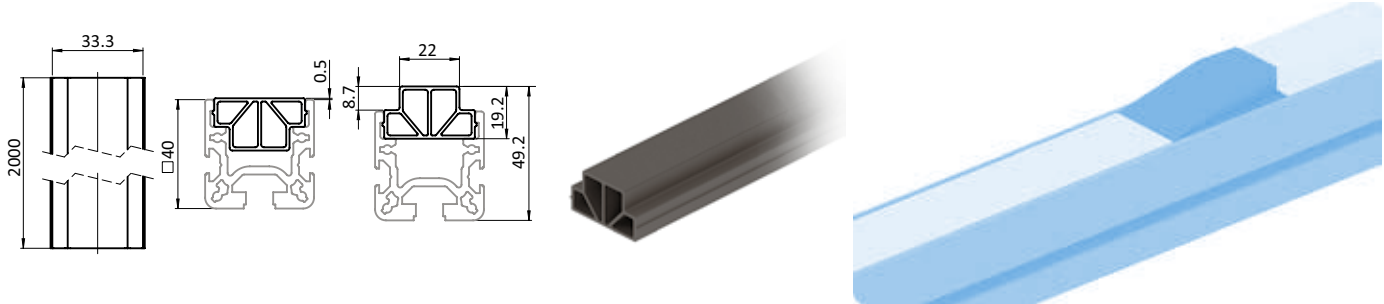

Gleitleiste AL Slide Rail AL	Tragkraft [N] Max. Load [N]	Gewicht [g/m] Weight [g/m]	Teil-Nr. Part #
	100	324.0	062AS91.2000
elektrostatisch entladend ⚡ electrostatically discharging	100	324.0	062AS91ESD.2000

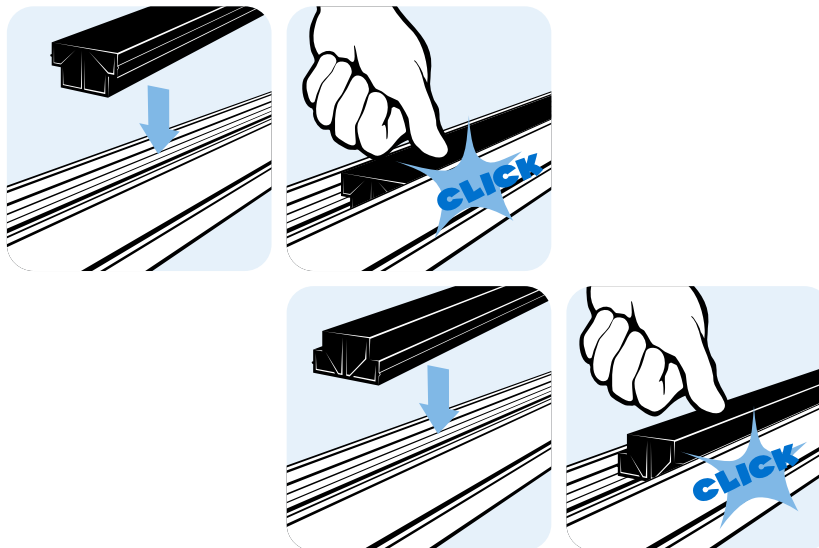

8



GLEITRAMPE AL

TRANSITION RAMP AL

Ausführung	für Rollenschienen AL	Model	For roller tracks AL
Beschreibung	für den sanften Übergang zwischen unterschiedlichen Höhenlagen; passend für Gleitleiste AL oder auch Rollenelemente, Bürstenelement oder Kugelement	Description	Provides a smooth transition between different levels; compatible with the slide rail AL but also with roller units, brush unit, and ball unit
Material	Standard-Gleitrampe: Kunststoff PA, glasfaserverstärkt ⚡elektrostatisch entladende Gleitrampe: Kunststoff PA, kohlefaserverstärkt	Material	Standard transition ramp: Plastic PA, glass fiber reinforced ⚡electrostatically discharging transition ramp: Plastic PA, carbon fiber reinforced
Farbe	schwarz	Color	Black
Liefereinheit	10 Stück	Pack Quantity	10 pieces
Extras	weitere Materialien, weitere Farben auf Anfrage	Specials	Other materials, other colors on request
Hinweis	passende Gleitleiste AL siehe Seite 616	Tip	Compatible slide rail AL see Seite 616

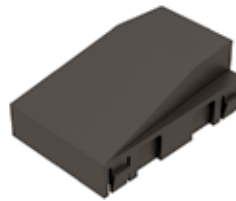
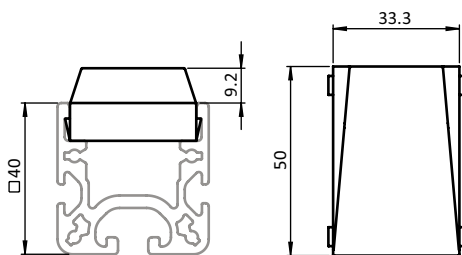

Gleitrampe AL
Transition Ramp AL

Gewicht [g]
Weight [g]

Teil-Nr.
Part #

	15.0	062AER91.50
elektrostatisch entladend ⚡ <i>electrostatically discharging</i>	13.0	062AER91ESD.50



GLEITLEISTE

SLIDE RAIL

Ausführung	Kunststoff PE-HD, Nut 8	Model	Plastic HDPE, Slot 8
Beschreibung	zum leichten Bewegen von Waren und Werkstückträgern oder als Auflageschutz für empfindliche Gegenstände, vertikal verbaut auch als Anschlagleiste oder Führungsleiste verwendbar; verschleißfest durch geringe Gleitreibung	Description	To easily move goods or carriers, or as a protection cover for sensitive material, used vertically also suitable as stop or guide bar; wear-resistant due to its low sliding friction
Material	Kunststoff PE-HD	Material	Plastic HDPE
Farbe	schwarz	Color	Black
Liefereinheit	50 Meter (25 St. à 2m)	Pack Quantity	50 meters (25 pieces at 2m)
Extras	weitere Farben auf Anfrage	Specials	Other colors on request
Hinweis	Bitte beachten: Sie bestellen in Meter!	Tip	Please note: You are ordering in meters!

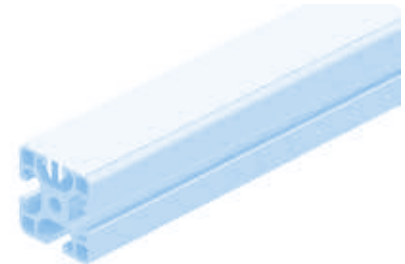
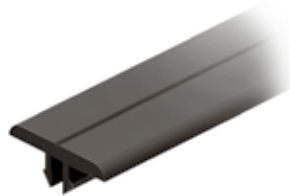
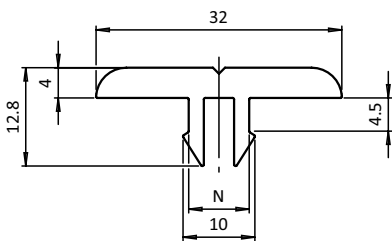

Abdeckprofil Cover Profile	N	Gewicht [g/m] Weight [g/m]	Profil Profile	Teil-Nr. Part #
	8	262.0	I	092095
elektrostatisch entladend ⚡ electrostatically discharging	8	260.0	I	092095S01



ROLLENSCHIENE ST R28

ROLLER TRACK ST R28

<p>Ausführung fertig montiert</p> <p>Beschreibung belastbare und laufruhige Rollenschiene ST R28, wahlweise ohne oder mit Spurkranz als seitliche Führung</p> <p>Material Rollenschienen-Profil ST: Stahl Standard-Rolle: Kunststoff PA, glaskugelverstärkt ⚡elektrostatisch entladende Rolle: Kunststoff PA, kohlefaserverstärkt Standard-Käfig: Kunststoff PA, glasfaserverstärkt ⚡elektrostatisch entladender Käfig: Kunststoff PA, kohlefaserverstärkt Achse: Stahl Standard-Klemmleiste: Kunststoff PP ⚡elektrostatisch entladende Klemmleiste: Kunststoff PP, kohlefaserverstärkt</p> <p>Farbe Rolle: siehe Tabelle Klemmleiste: schwarz</p> <p>Liefereinheit 1 Stück à 4500 mm Zuschnitt min. 100 mm - max. 4500 mm</p> <p>Extras weitere Materialien, weitere Farben auf Anfrage</p> <p>Hinweis Bitte beachten: Sie bestellen in Meter! Für Zuschnitt: bitte ersetzen Sie "xxxx" in der Teil-Nr. mit der gewünschten Länge in mm, z.B. "0100" für 100 mm oder "4500" für 4500 mm</p>	<p>Model Assembled ready for use</p> <p>Description Resilient and smooth running roller track ST R28, with or without flange as lateral guiding</p> <p>Material Roller track profile ST: Steel Standard roller: Plastic PA, glass ball reinforced ⚡electrostatically discharging roller: Plastic PA, carbon fiber reinforced Standard cage: Plastic PA, glass fiber reinforced ⚡electrostatically discharging cage: Plastic PA, carbon fiber reinforced Axle: Steel Standard clamping strip: Plastic PP ⚡electrostatically discharging clamping strip: Plastic PP, carbon fiber reinforced</p> <p>Color Roller: See table Clamping strip: Black</p> <p>Pack Quantity 1 piece at 4500 mm; Cut min. 100 mm - max. 4500 mm</p> <p>Specials Other materials, other colors on request</p> <p>Tip Please note: You are ordering in meters! For cut: To order, please replace "xxxx" in the part number by the required length in mm, e.g. "0100" for 100 mm or "4500" for 4500 mm</p>
---	--

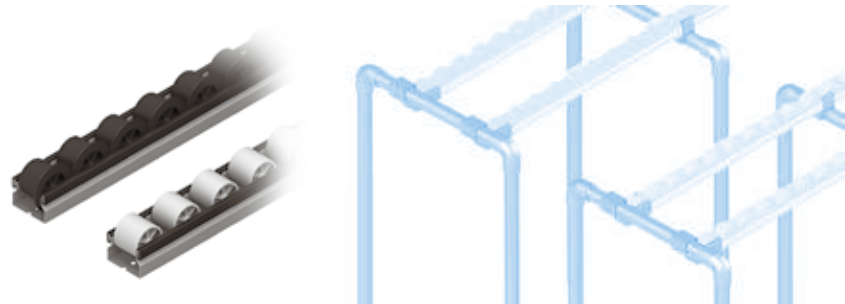
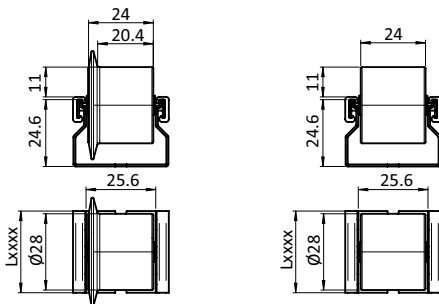

Rollenschiene ST R28 <i>Roller Track ST R28</i>	ESD	Farbe Rolle <i>Color of Roller</i>	Tragkraft [N] <i>Max. Load [N]</i>	Gewicht [g/m] <i>Weight [g/m]</i>	Teil-Nr. <i>Part #</i>
ohne Spurkranz (Achsabstand 30 mm) <i>Without flange (axle distance 30 mm)</i>		schwarz <i>Black</i>	150	750.0	6MPR2891.4500
		schwarz <i>Black</i>	150	750.0	6MPR2891.xxxx
	⚡	schwarz <i>Black</i>	125	720.0	6MPR2891ESD.4500
	⚡	schwarz <i>Black</i>	125	720.0	6MPR2891ESD.xxxx
		grau ≈ RAL 7042 <i>Gray</i>	150	750.0	6MPR2874.4500
		grau ≈ RAL 7042 <i>Gray</i>	150	750.0	6MPR2874.xxxx
		schwarz <i>Black</i>	150	780.0	6MPR28F91.xxxx
	⚡	schwarz <i>Black</i>	125	750.0	6MPR28F91ESD.4500
	⚡	schwarz <i>Black</i>	125	750.0	6MPR28F91ESD.xxxx
		grau ≈ RAL 7042 <i>Gray</i>	150	780.0	6MPR28F74.4500
		grau ≈ RAL 7042 <i>Gray</i>	150	780.0	6MPR28F74.xxxx



ROLLENSCHIENE AL R28

ROLLER TRACK AL R28

Ausführung	fertig montiert	Model	Assembled ready for use
Beschreibung	belastbare und laufruhige Rollenschiene AL R28, schnell austauschbar, wahlweise ohne oder mit Spurkranz als seitliche Führung	Description	Resilient and smooth running roller track AL R28, quickly replaceable, with or without flange as lateral guiding
Material	Rollenschienen-Profil AL: Aluminium Standard-Rolle: Kunststoff PA, glaskugelverstärkt ⚡elektrostatisch entladende Rolle: Kunststoff PA, kohlefaserverstärkt Standard-Käfig: Kunststoff PA, glasfaserverstärkt ⚡elektrostatisch entladender Käfig: Kunststoff PA, kohlefaserverstärkt Achse: Stahl	Material	Roller track profile AL: Aluminum Standard roller: Plastic PA, glass ball reinforced ⚡electrostatically discharging roller: Plastic PA, carbon fiber reinforced Standard cage: Plastic PA, glass fiber reinforced ⚡electrostatically discharging cage: Plastic PA, carbon fiber reinforced Axle: Steel
Farbe	Standard-Rolle / Standard-Käfig: siehe Tabelle ⚡elektrostatisch entladende Rolle / Käfig: siehe Tabelle	Color	Standard roller / cage: See table ⚡electrostatically discharging roller / cage: See table
Liefereinheit	1 Stück à 6000 mm Zuschnitt min. 50 mm - max. 6000 mm	Pack Quantity	1 piece at 6000 mm; Cut min. 50 mm - max. 6000 mm
Extras	weitere Materialien, weitere Farben auf Anfrage	Specials	Other materials, other colors on request
Hinweis	Bitte beachten: Sie bestellen in Meter! Für Zuschnitt: bitte ersetzen Sie "xxxx" in der Teil-Nr. mit der gewünschten Länge in mm, z.B. "0350" für 350 mm oder "2000" für 2000 mm	Tip	Please note: You are ordering in meters! For cut: To order, please replace "xxxx" in the part number by the required length in mm, e.g. "0350" for 350 mm or "2000" for 2000 mm

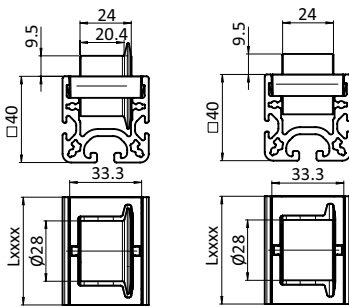

Rollenschiene AL R28 Roller Track AL R28	ESD	Farbe Käfig Color of Cage	Farbe Rolle Color of Roller	Tragkraft [N] Max. Load [N]	Gewicht [g/m] Weight [g/m]	Profil Profile	Teil-Nr. Part #
ohne Spurkranz (Achsabstand 50 mm) Without flange (axle distance 50 mm)		schwarz <i>Black</i>	schwarz <i>Black</i>	150	1665.0	I	6APR2891I.6000
		schwarz <i>Black</i>	schwarz <i>Black</i>	150	1665.0	I	6APR2891I.xxxx
		schwarz <i>Black</i>	schwarz <i>Black</i>	150	1665.0	B	6APR2891B.6000
		schwarz <i>Black</i>	schwarz <i>Black</i>	150	1665.0	B	6APR2891B.xxxx
	⚡	schwarz <i>Black</i>	schwarz <i>Black</i>	125	1605.0	I	6APR2891IESD.6000
	⚡	schwarz <i>Black</i>	schwarz <i>Black</i>	125	1605.0	I	6APR2891IESD.xxxx
	⚡	schwarz <i>Black</i>	schwarz <i>Black</i>	125	1605.0	B	6APR2891BESD.6000
	⚡	schwarz <i>Black</i>	schwarz <i>Black</i>	125	1605.0	B	6APR2891BESD.xxxx
		grau ≈ RAL 7042 <i>Gray</i>	grau ≈ RAL 7042 <i>Gray</i>	150	1665.0	I	6APR2874I.6000
		grau ≈ RAL 7042 <i>Gray</i>	grau ≈ RAL 7042 <i>Gray</i>	150	1665.0	I	6APR2874I.xxxx
		grau ≈ RAL 7042 <i>Gray</i>	grau ≈ RAL 7042 <i>Gray</i>	150	1665.0	B	6APR2874B.6000
		grau ≈ RAL 7042 <i>Gray</i>	grau ≈ RAL 7042 <i>Gray</i>	150	1665.0	B	6APR2874B.xxxx



ROLLENSCHIENE AL R28

ROLLER TRACK AL R28

<p>Ausführung fertig montiert</p> <p>Beschreibung belastbare und laufruhige Rollenschiene AL R28, schnell austauschbar, wahlweise ohne oder mit Spurkranz als seitliche Führung</p> <p>Material Rollenschienen-Profil AL: Aluminium Standard-Rolle: Kunststoff PA, glaskugelverstärkt ⚡elektrostatisch entladende Rolle: Kunststoff PA, kohlefaserverstärkt Standard-Käfig: Kunststoff PA, glasfaserverstärkt ⚡elektrostatisch entladender Käfig: Kunststoff PA, kohlefaserverstärkt Achse: Stahl</p> <p>Farbe Standard-Rolle / Standard-Käfig: siehe Tabelle ⚡elektrostatisch entladende Rolle / Käfig: siehe Tabelle</p> <p>Liefereinheit 1 Stück à 6000 mm Zuschnitt min. 50 mm - max. 6000 mm</p> <p>Extras weitere Materialien, weitere Farben auf Anfrage</p> <p>Hinweis Bitte beachten: Sie bestellen in Meter! Für Zuschnitt: bitte ersetzen Sie "xxxx" in der Teil-Nr. mit der gewünschten Länge in mm, z.B. "0350" für 350 mm oder "2000" für 2000 mm</p>	<p>Model Assembled ready for use</p> <p>Description Resilient and smooth running roller track AL R28, quickly replaceable, with or without flange as lateral guiding</p> <p>Material Roller track profile AL: Aluminum Standard roller: Plastic PA, glass ball reinforced ⚡electrostatically discharging roller: Plastic PA, carbon fiber reinforced Standard cage: Plastic PA, glass fiber reinforced ⚡electrostatically discharging cage: Plastic PA, carbon fiber reinforced Axle: Steel</p> <p>Color Standard roller / cage: See table ⚡electrostatically discharging roller / cage: See table</p> <p>Pack Quantity 1 piece at 6000 mm; Cut min. 50 mm - max. 6000 mm</p> <p>Specials Other materials, other colors on request</p> <p>Tip Please note: You are ordering in meters! For cut: To order, please replace "xxxx" in the part number by the required length in mm, e.g. "0350" for 350 mm or "2000" for 2000 mm</p>
--	--

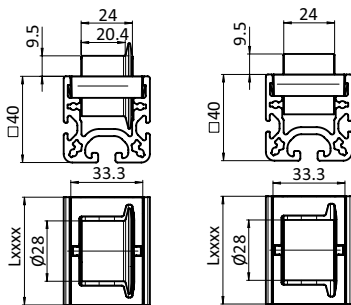

Rollenschiene AL R28 Roller Track AL R28	ESD	Farbe Käfig Color of Cage	Farbe Rolle Color of Roller	Tragkraft [N] Max. Load [N]	Gewicht [g/m] Weight [g/m]	Profil Profile	Teil-Nr. Part #
mit Spurkranz (Achsabstand 50 mm) With flange (axle distance 50 mm)		schwarz Black	schwarz Black	150	1725.0	I	6APR28F91I.xxxx
		schwarz Black	schwarz Black	150	1725.0	B	6APR28F91B.xxxx
	⚡	schwarz Black	schwarz Black	125	1625.0	I	6APR28F91IESD.6000
	⚡	schwarz Black	schwarz Black	125	1625.0	I	6APR28F91IESD.xxxx
	⚡	schwarz Black	schwarz Black	125	1625.0	B	6APR28F91BESD.6000
	⚡	schwarz Black	schwarz Black	125	1625.0	B	6APR28F91BESD.xxxx
		grau ≈ RAL 7042 Gray	grau ≈ RAL 7042 Gray	150	1725.0	I	6APR28F74I.6000
		grau ≈ RAL 7042 Gray	grau ≈ RAL 7042 Gray	150	1725.0	I	6APR28F74I.xxxx
		grau ≈ RAL 7042 Gray	grau ≈ RAL 7042 Gray	150	1725.0	B	6APR28F74B.6000
		grau ≈ RAL 7042 Gray	grau ≈ RAL 7042 Gray	150	1725.0	B	6APR28F74B.xxxx



ROLLENSCHIENEN-PROFIL AL

ROLLER TRACK PROFILE AL

Ausführung	Aluminium	Model	Aluminium
Beschreibung	eigenstabiles Rollenschienen-Profil AL zum Bestücken mit Rollen-, Kugel-, Bürsten- oder Gleitelementen, einfaches Befestigen an den jeweiligen Systemnuten I (Nut 5/8) und B (Nut 6/10)	Description	Rigid roller track profile AL which can be equipped with roller units, ball units, or slide rails; for easy assembly with the respective profile system slot I (slot 5/8) or B (6/10)
Material	Aluminium	Material	Aluminium
Liefereinheit	1 Stück à 6000 mm Zuschnitt min. 50 mm - max. 6000 mm	Pack Quantity	1 piece at 6000 mm; Cut min. 50 mm - max. 6000 mm
Hinweis	Bitte beachten: Sie bestellen in Meter! Für Zuschnitt: bitte ersetzen Sie "xxxx" in der Teil-Nr. mit der gewünschten Länge in mm, z.B. "0350" für 350 mm oder "2000" für 2000 mm	Tip	Please note: You are ordering in meters! For cut: To order, please replace "xxxx" in the part number by the required length in mm, e.g. "0350" for 350 mm or "2000" for 2000 mm

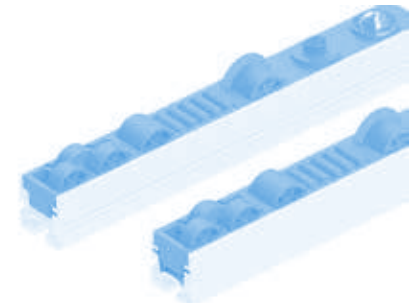
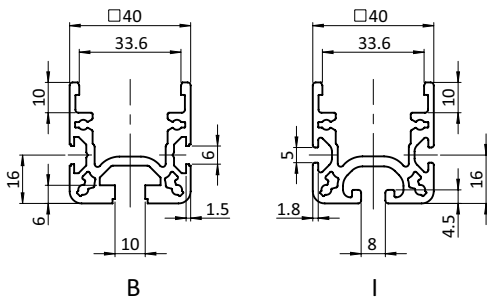

Rollenschienen-Profil AL Roller Track Profile AL	Gewicht [g/m] Weight [g/m]	Profil Profile	Teil-Nr. Part #
	1285.0	I	062API.6000
	1285.0	I	062API.xxxx
	1285.0	B	062APB.6000
	1285.0	B	062APB.xxxx
⚡ elektrostatisch entladend bearbeitet electrostatically discharging processed	1285.0	I	062APIESD.6000
	1285.0	I	062APIESD.xxxx
	1285.0	B	062APBESD.6000
	1285.0	B	062APBESD.xxxx



EINHÄNGEHALTER AL D28

HOLDING BRACKET AL D28

Ausführung	für Rollenschienen AL	Model	For roller tracks AL
Beschreibung	zum Einhängen von Rollenschienen AL in ein Rundrohrprofil mit Außendurchmesser Ø 28 mm, verhindert das Herausrutschen von Einsätzen	Description	To mount roller track profiles AL to tubular frame profiles with Ø 28 mm outer diameter, preventing inserts from slipping out
Material	Stahl	Material	Steel
Montageset	5 Bohrschrauben DIN 7504 Form N - 3,9 × 16	Assembly Set	5 self-drilling screws DIN 7504 Form N - 3.9 × 16
Liefereinheit	10 Stück	Pack Quantity	10 pieces
Extras	weitere Oberflächen, weitere Farben auf Anfrage	Specials	Other surfaces, other colors on request

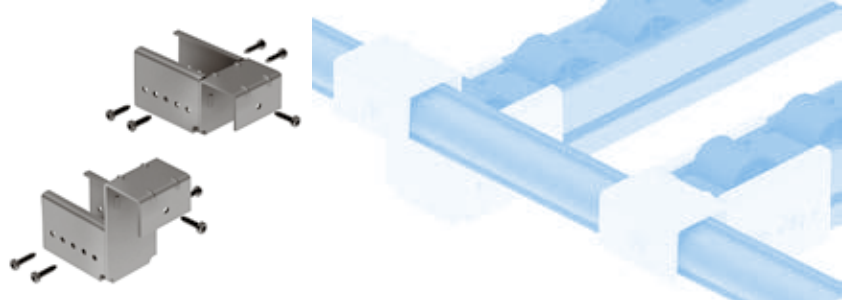
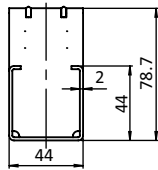
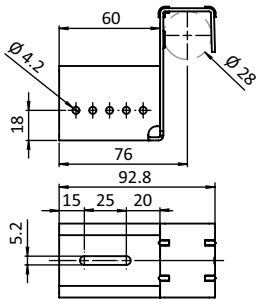

Einhängehalter AL D28 Holding Bracket AL D28	Gewicht [g] Weight [g]	Teil-Nr. Part #
ohne Anschlag <i>Without end stop</i>	176.0	062AHD28M
mit Anschlag <i>With end stop</i>	198.5	062AHS28M
ohne Anschlag inkl. Montageset <i>Without end stop, with assembly set</i>	186.0	062AHD28MS01
mit Anschlag inkl. Montageset <i>With end stop, with assembly set</i>	208.5	062AHS28MS01

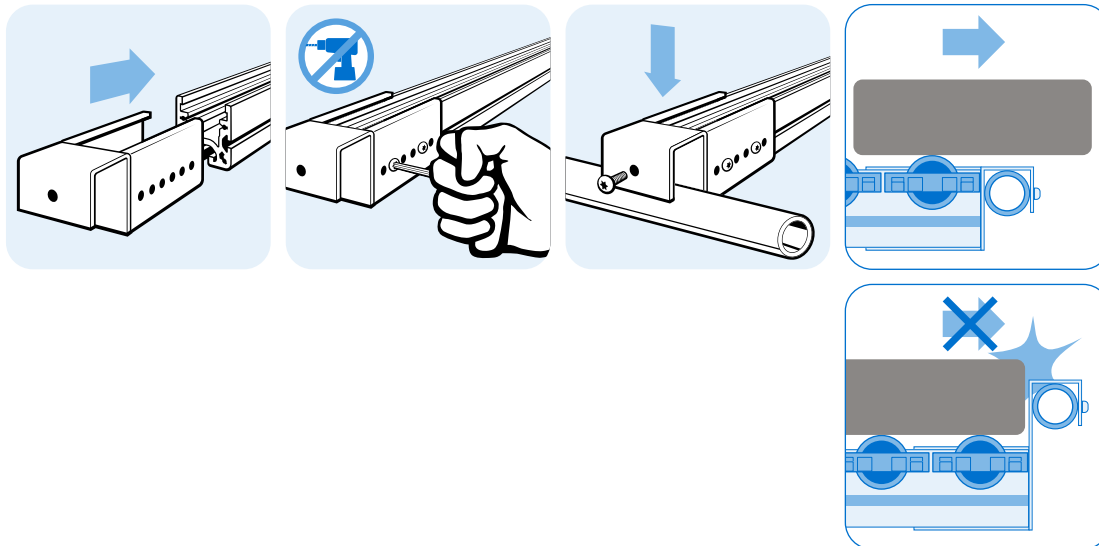



VARIABLER HALTER AL D28

VARIABLE HOLDING BRACKET AL D28

<p>Ausführung für Rollenschienen AL</p> <p>Beschreibung für Rollschienenübergang mit wechselndem Gefälle, zum Einhängen von Rollschienen AL mit variablem Neigungswinkel in ein Rundrohrprofil mit Außendurchmesser Ø 28 mm, verhindert das Herausrutschen von Einsätzen</p> <p>Material Stahl</p> <p>Oberfläche verzinkt</p> <p>Montageset 1 5 Bohrschrauben DIN 7504 Form N - 3,9 x 16</p> <p>Montageset 2 6 Bohrschrauben DIN 7504 Form N - 3,9 x 16</p> <p>Liefereinheit 10 Stück</p> <p>Extras weitere Oberflächen, weitere Farben auf Anfrage</p>	<p>Model For roller tracks AL</p> <p>Description Transition between roller track profiles with varying inclination, to mount roller track profiles AL at different angles to tubular frame profiles with Ø 28 mm outer diameter, preventig inserts from slipping out</p> <p>Material Steel</p> <p>Surface Zinc plated</p> <p>Assembly Set 1 5 self-drilling screws DIN 7504 Form N - 3.9 x 16</p> <p>Assembly Set 2 6 self-drilling screws DIN 7504 Form N - 3.9 x 16</p> <p>Pack Quantity 10 pieces</p> <p>Specials Other surfaces, other colors on request</p>
---	--

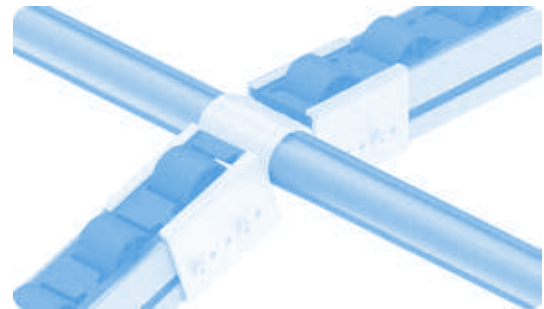
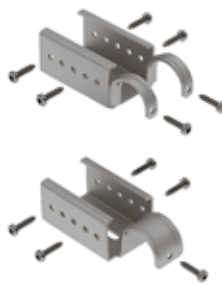
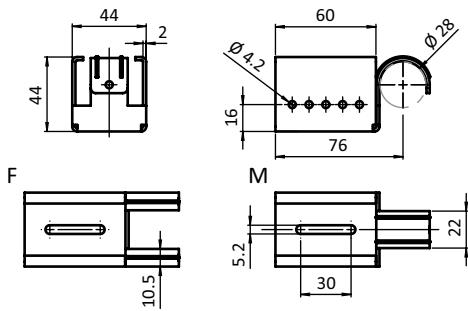

Variable Halter AL D28
Variable Holding Bracket AL D28

	Gewicht [g] Weight [g]	Teil-Nr. Part #
Typ M	144.0	062AYMD28M
Typ F	142.0	062AYFD28M
Typ M inkl. Montageset 1 <i>Type M with assembly set 1</i>	154.0	062AYMD28MS01
Typ F inkl. Montageset 2 <i>Type F with assembly set 2</i>	154.0	062AYFD28MS01

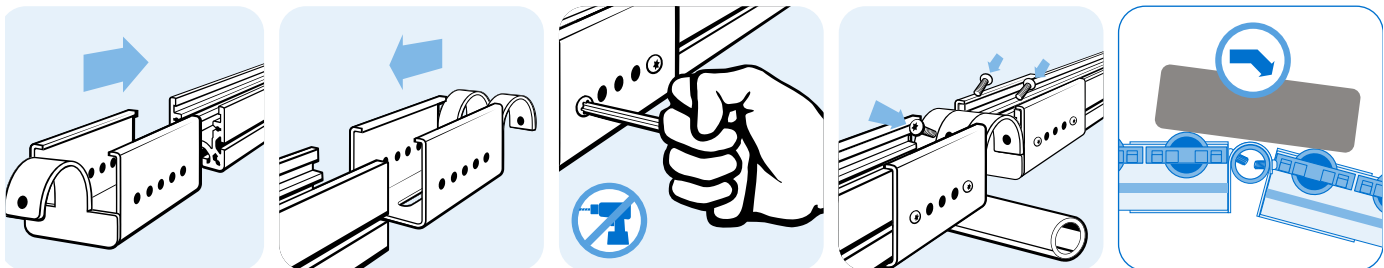



MONTAGEHALTER AL D28

MOUNTING BRACKET AL D28

<p>Ausführung für Rollenschienen AL</p> <p>Beschreibung zum Einhängen und Abstützen einer kreuzenden Rollenschiene AL über einem Rundrohrprofil mit Außendurchmesser $\varnothing 28$ mm</p> <p>Material Stahl</p> <p>Montageset 6 Bohrschrauben DIN 7504 Form N - 3,9 x 16</p> <p>Liefereinheit 10 Stück</p> <p>Extras weitere Oberflächen, weitere Farben auf Anfrage</p>	<p>Model For roller tracks AL</p> <p>Description To mount and support an roller track profile AL on a crossing tubular frame profile with $\varnothing 28$ mm outer diameter</p> <p>Material Steel</p> <p>Assembly Set 6 self-drilling screws DIN 7504 Form N - 3.9 x 16</p> <p>Pack Quantity 10 pieces</p> <p>Specials Other surfaces, other colors on request</p>
--	--

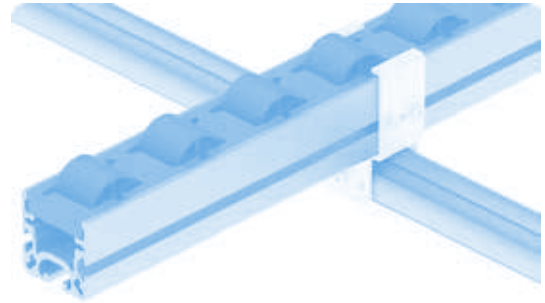
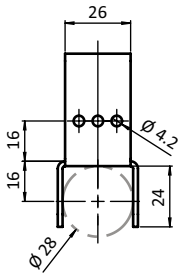

Montagehalter AL D28
Mounting Bracket AL D28

Gewicht [g]
Weight [g]

Teil-Nr.
Part #

	76.0	062AMD28M
inkl. Montageset <i>With assembly set</i>	88.0	062AMD28MS01

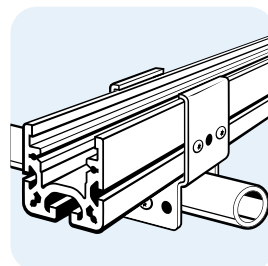
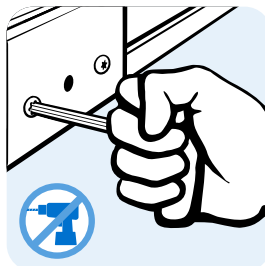
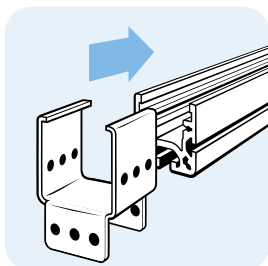



EINHÄNGEHALTER ST D28

HOLDING BRACKET ST D28

Ausführung	für Rollenschienen ST	Model	For roller tracks ST
Beschreibung	zum Einhängen von Rollenschienen ST und Führungsschienen ST zentral in ein Rundrohrprofil mit Außendurchmesser \varnothing 28 mm, verhindert das Herausrutschen von Einsätzen	Description	To mount roller tracks ST and guiding rails ST central to tubular frame profiles with \varnothing 28 mm outer diameter, preventing inserts from slipping out
Material	Stahl	Material	Steel
Befestigung	mit 3 Bohrschrauben DIN 7504 Form N - 3,9 × 16	Fastening	With 3 self-drilling screws DIN 7504 Form N - 3.9 × 16
Liefereinheit	10 Stück	Pack Quantity	10 pieces
Extras	weitere Oberflächen, weitere Farben auf Anfrage	Specials	Other surfaces, other colors on request



Einhängehalter ST D28 Holding Bracket ST D28	Gewicht [g] Weight [g]	Teil-Nr. Part #
ohne Anschlag <i>Without end stop</i>	135.8	062MHD28M
mit Anschlag <i>With end stop</i>	156.1	062MHSD28M



VARIABLE HALTER ST D28

VARIABLE HOLDING BRACKET ST D28

Ausführung	für Rollenschienen ST	Model	For roller tracks ST
Beschreibung	für Rollenschienenübergang mit wechselndem Gefälle, zum Einhängen von Rollenschienen ST und Führungsschienen St zentral mit variablem Neigungswinkel in ein Rundrohrprofil mit Außendurchmesser \varnothing 28 mm, verhindert das Herausrutschen von Einsätzen	Description	Transition between roller tracks with varying inclination, to mount roller tracks ST and guiding rails ST central at different angles to tubular frame profiles with \varnothing 28 mm outer diameter, preventing inserts from slipping out
Material	Stahl	Material	Steel
Befestigung	mit 3 oder 4 Bohrschrauben DIN 7504 Form N - 3,9 x 16	Fastening	With 3 or 4 self-drilling screws DIN 7504 Form N - 3.9 x 16
Liefereinheit	10 Stück	Pack Quantity	10 pieces
Extras	weitere Oberflächen, weitere Farben auf Anfrage	Specials	Other surfaces, other colors on request

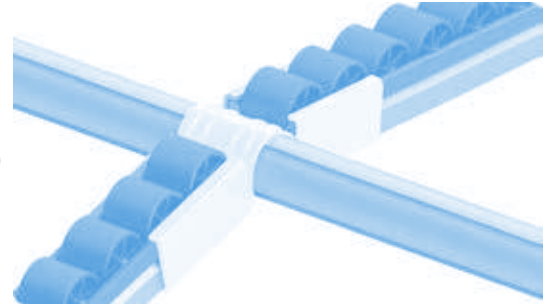
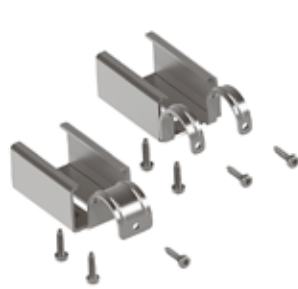
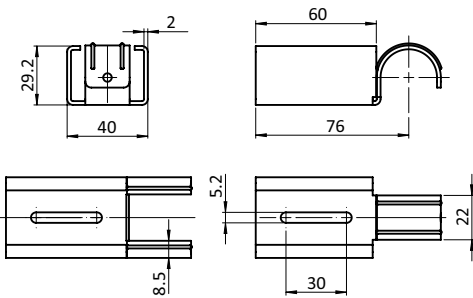

Variabler Halter ST D28
Variable Holding Bracket ST D28

Gewicht [g]
Weight [g]

Teil-Nr.
Part #

	Gewicht [g] Weight [g]	Teil-Nr. Part #
Typ M	106.0	062MYMD28M
Typ F	103.0	062MYFD28M



MONTAGEHALTER ST D28

MOUNTING BRACKET ST D28

<p>Ausführung für Rollenschienen ST</p> <p>Beschreibung zum Einhängen und Abstützen einer kreuzenden Rollenschiene ST oder einer Führungsschiene ST zentral über einem Rundrohrprofil mit Außen-durchmesser ϕ 28 mm</p> <p>Material Stahl</p> <p>Befestigung mit 2 bis 6 Bohrschrauben DIN 7504 Form N - 3,9 x 16</p> <p>Liefereinheit 10 Stück</p> <p>Extras weitere Oberflächen, weitere Farben auf Anfrage</p>	<p>Model For roller tracks ST</p> <p>Description To mount and support an roller track ST or a guiding rail ST centrally on a crossing tubular frame profile with ϕ 28 mm outer diameter</p> <p>Material Steel</p> <p>Fastening with 2 till 6 self-drilling screws DIN 7504 Form N - 3.9 x 16</p> <p>Pack Quantity 10 pieces</p> <p>Specials Other surfaces, other colors on request</p>
---	---

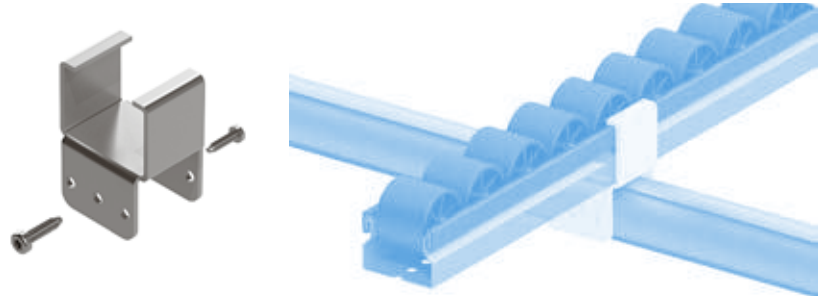
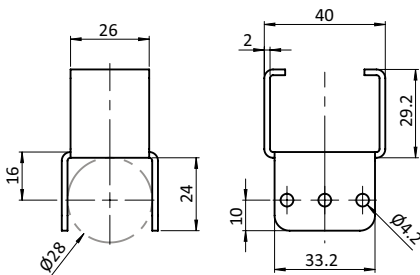

Montagehalter ST D28
Mounting Bracket ST D28

Gewicht [g]
Weight [g]

Teil-Nr.
Part #

64.0

062MMD28M



ABSCHLUSSPLATTE AL

END PLATE AL

Ausführung für Rollenschienen AL
Beschreibung zum Verschließen der Stirnseite von Rollenschienen-Profilen AL, verhindert das Herausrutschen von Einsätzen, in der langen Ausführung gleichzeitig mit Anschlag (optional kann ein Anschlagpuffer montiert werden)
Material Stahl
Montageset 4 Bohrschrauben DIN 7504 Form N - 3,9 × 16
Liefereinheit 10 Stück
Extras weitere Oberflächen, weitere Farben auf Anfrage
Hinweis passender Anschlagpuffer siehe Seite 651

Model For roller tracks AL
Description To close the end face of roller track profiles AL, preventig inserts from slipping out, additionally the long version has an end stop (optionally, a buffer stop can be added)
Material Steel
Assembly Set 4 self-drilling screws DIN 7504 Form N - 3.9 × 16
Pack Quantity 10 pieces
Specials Other surfaces, other colors on request
Tip Compatible buffer stop see page 651

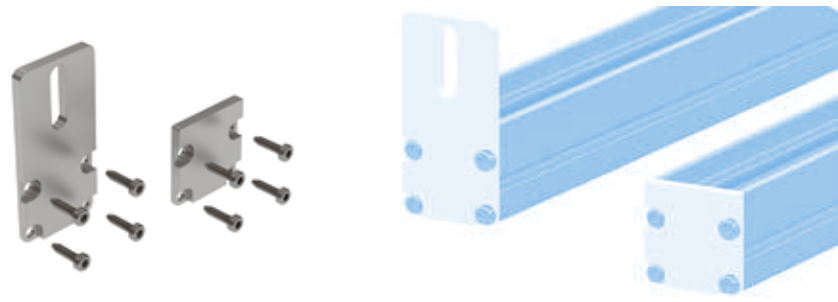
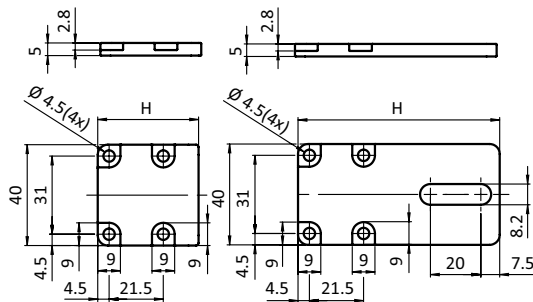

Abschlussplatte AL End Plate AL	H [mm]	Gewicht [g] Weight [g]	Teil-Nr. Part #
ohne Anschlag <i>Without end stop</i>	40	55.0	062AT4040
mit Anschlag <i>With end stop</i>	80	108.0	062ATS4080
ohne Anschlag inkl. Montageset <i>Without end stop, with assembly set</i>	40	63.0	062AT4040S01
mit Anschlag inkl. Montageset <i>With end stop, with assembly set</i>	80	124.0	062ATS4080S01

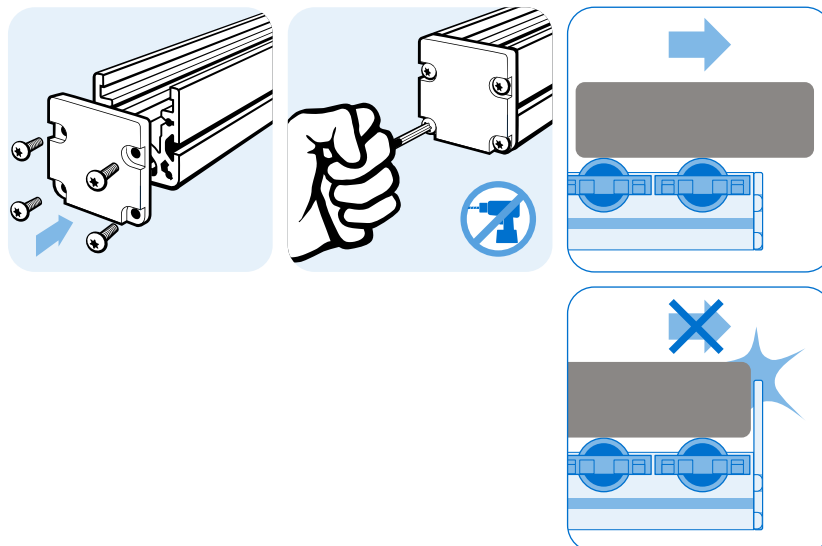



FÜHRUNGSSCHIENE ST

GUIDING RAIL ST

Ausführung	für Rollenschiene ST	Model	For roller tracks ST
Beschreibung	zur sicheren Führung und Positionierung von flexiblen Transportwegen, Führungsschienen sorgen für ausreichende Höhe in der Warenbereitstellung	Description	For a safe guiding and positioning in flexible conveyor facilities, guiding rails provide for an adequate work height for the product supply
Material	Standard-Ausführung: Kunststoff PVC ⚡ elektrostatisch entladende Ausführung: Kunststoff PVC, kohlefaserverstärkt	Material	Standard version: Plastic PVC ⚡ electrostatically discharging version: Plastic PVC, carbon fiber reinforced
Liefereinheit	1 Stück à 4500 mm Zuschnitt min. 100 mm - max. 4500 mm	Pack Quantity	1 piece at 4500 mm; Cut min. 100 mm - max. 4500 mm
Extras	weitere Farben auf Anfrage	Specials	Other colors on request
Hinweis	Bitte beachten: Sie bestellen in Meter! Für Zuschnitt: bitte ersetzen Sie "xxxx" in der Teil-Nr. mit der gewünschten Länge in mm, z.B. "0100" für 100 mm oder "4500" für 4500 mm	Tip	Please note: You are ordering in meters! For cut: To order, please replace "xxxx" in the part number by the required length in mm, e.g. "0100" for 100 mm or "4500" for 4500 mm

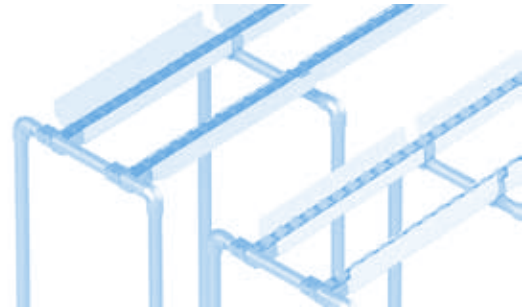
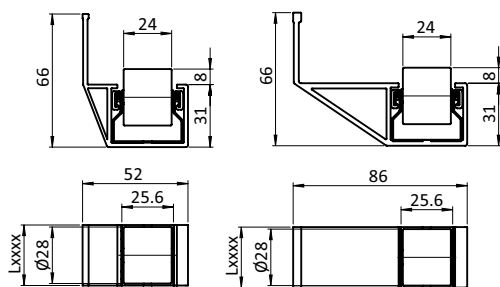

Führungsschiene ST <i>Guiding Rail ST</i>	Breite [mm] <i>Width [mm]</i>	ESD	Farbe <i>Color</i>	Gewicht [g/m] <i>Weight [g/m]</i>	Teil-Nr. <i>Part #</i>
seitlich 32 <i>Lateral 32</i>	52.0		schwarz <i>Black</i>	600.0	062MGRL3291.4500
	52.0		schwarz <i>Black</i>	600.0	062MGRL3291.xxxx
	52.0	⚡	schwarz <i>Black</i>	530.0	062MGRL3291ESD.4500
	52.0	⚡	schwarz <i>Black</i>	530.0	062MGRL3291ESD.xxxx
	52.0		grau ≈ RAL 7042 <i>Gray</i>	600.0	062MGRL3274.4500
	52.0		grau ≈ RAL 7042 <i>Gray</i>	600.0	062MGRL3274.xxxx
seitlich 65 <i>Lateral 65</i>	86.0		schwarz <i>Black</i>	890.0	062MGRL6591.4500
	86.0		schwarz <i>Black</i>	890.0	062MGRL6591.xxxx
	86.0	⚡	schwarz <i>Black</i>	770.0	062MGRL6591ESD.4500
	86.0	⚡	schwarz <i>Black</i>	770.0	062MGRL6591ESD.xxxx
	86.0		grau ≈ RAL 7042 <i>Gray</i>	890.0	062MGRL6574.4500
	86.0		grau ≈ RAL 7042 <i>Gray</i>	890.0	062MGRL6574.xxxx



FÜHRUNGSSCHIENE ST

GUIDING RAIL ST

Ausführung	für Rollenschiene ST	Model	For roller tracks ST
Beschreibung	zur sicheren Führung und Positionierung von flexiblen Transportwegen, Führungsschienen sorgen für ausreichende Höhe in der Warenbereitstellung; Befestigung mit Haltern für Rollenschienen ST	Description	For a safe guiding and positioning in flexible conveyor facilities, guiding rails provide for an adequate work height for the product supply; fastening with brackets for ST roller tracks
Material	Standard-Ausführung: Kunststoff PVC ⚡ elektrostatisch entladende Ausführung: Kunststoff PVC, kohlefaserverstärkt	Material	Standard version: Plastic PVC ⚡ electrostatically discharging version: Plastic PVC, carbon fiber reinforced
Liefereinheit	1 Stück à 4500 mm Zuschnitt min. 100 mm - max. 4500 mm	Pack Quantity	1 piece at 4500 mm; Cut min. 100 mm - max. 4500 mm
Extras	weitere Farben auf Anfrage	Specials	Other colors on request
Hinweis	Bitte beachten: Sie bestellen in Meter! Für Zuschnitt: bitte ersetzen Sie "xxxx" in der Teil-Nr. mit der gewünschten Länge in mm, z.B. "0100" für 100 mm oder "4500" für 4500 mm. passende Halter für Rollenschienen ST siehe Seite 626, Seite 627 und Seite 628	Tip	Please note: You are ordering in meters! For cut: To order, please replace "xxxx" in the part number by the required length in mm, e.g. "0100" for 100 mm or "4500" for 4500 mm. Compatible Brackets for ST roller tracks see page 626, page 627 und page 628

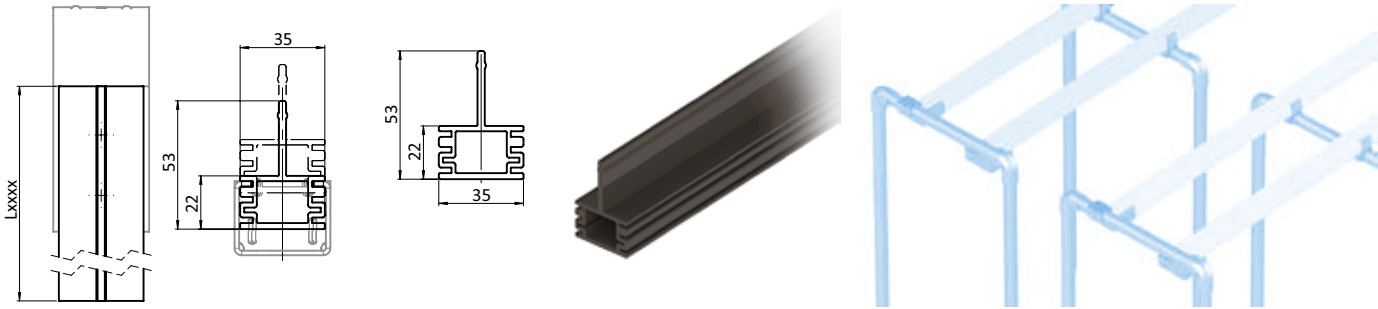

Führungsschiene ST Guiding Rail ST	ESD	Farbe Color	Gewicht [g/m] Weight [g/m]	Teil-Nr. Part #
zentral Central		schwarz <i>Black</i>	560.0	062MGRC91.4500
		schwarz <i>Black</i>	560.0	062MGRC91.xxxx
	⚡	schwarz <i>Black</i>	390.0	062MGRC91ESD.4500
	⚡	schwarz <i>Black</i>	390.0	062MGRC91ESD.xxxx
		grau ≈ RAL 7042 <i>Gray</i>	560.0	062MGRC74.4500
		grau ≈ RAL 7042 <i>Gray</i>	560.0	062MGRC74.xxxx



ROLLENELEMENT L50 R28

ROLLER UNIT L50 R28

<p>Ausführung für Rollenschienen AL</p> <p>Beschreibung belastbares und laufruhiges Rollenelement R28 für Rollenschienen-Profile AL, wahlweise ohne oder mit Spurkranz als seitliche Führung, komplett vormontiert</p> <p>Material Standard-Rolle: Kunststoff PA, glaskugelverstärkt Standard-Käfig: Kunststoff PA, glasfaserverstärkt ⚡ elektrostatisch entladende Rolle und Käfig: Kunststoff PA, kohlefaserverstärkt Achse: Stahl</p> <p>Liefereinheit 10 Stück</p> <p>Extras farbige Rolle in grauem Käfig, weitere Materialien, weitere Farben auf Anfrage</p> <p>Hinweis Rollenelement L50 R28 bestehend aus: – Rolle R28, siehe Seite 638; – Achse AL, siehe Seite 641; – Käfig L50 für Rollen R28, siehe Seite 642; passende Bremse R28 siehe Seite 633</p>	<p>Model For roller tracks AL</p> <p>Description A resilient and smooth roller unit R28 for roller tracks AL, optionally without or with flange as lateral guiding, completely preassembled</p> <p>Material Standard roller: Plastic PA, glass reinforced Standard cage: Plastic PA, glass fiber reinforced ⚡ electrostatically discharging roller and cage: Plastic PA, carbon fiber reinforced Axle: Steel</p> <p>Pack Quantity 10 pieces</p> <p>Specials Colored rollers in gray cage, other materials, other colors on request</p> <p>Tip Roller unit L50 R28 consisting of: – Roller R28, see page 638; – Axle AL, see page 641 – Cage L50 for rollers R28, see page 642; compatible brake R28 see page 633</p>
---	--



Rollenelement L50 R28 Roller Unit L50 R28	ESD	Farbe Käfig Color of Cage	Farbe Rolle Color of Roller	Tragkraft [N] Max. Load [N]	Gewicht [g] Weight [g]	Teil-Nr. Part #
ohne Spurkranz Without flange		schwarz Black	schwarz Black	150	19.0	062AER2891.50
	⚡	schwarz Black	schwarz Black	125	16.5	062AER2891ESD.50
		schwarz Black	gelb ≈ RAL 1003 Yellow	150	19.0	062AER2811.50
		schwarz Black	rot ≈ RAL 3020 Red	150	19.0	062AER2831.50
		schwarz Black	grün ≈ RAL 6032 Green	150	19.0	062AER2861.50
		grau ≈ RAL 7042 Gray	grau ≈ RAL 7042 Gray	150	19.0	062AER2874.50
mit Spurkranz With flange		schwarz Black	schwarz Black	150	20.0	062AER28F91.50
	⚡	schwarz Black	schwarz Black	125	17.5	062AER28F91ESD.50
		schwarz Black	gelb ≈ RAL 1003 Yellow	150	20.0	062AER28F11.50
		schwarz Black	rot ≈ RAL 3020 Red	150	20.0	062AER28F31.50
		schwarz Black	grün ≈ RAL 6032 Green	150	20.0	062AER28F61.50
		grau ≈ RAL 7042 Gray	grau ≈ RAL 7042 Gray	150	20.0	062AER28F74.50

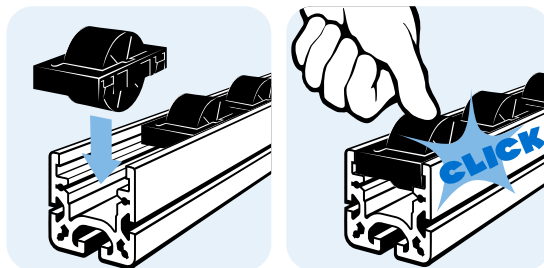



BREMSE R28

BRAKE R28

<p>Ausführung für Rollen R28 in Rollenschienen ST und AL</p> <p>Beschreibung zum Clipsen über 3 Rollen R28; sorgt für ein sanftes Abbremsen und die richtige Anfahr- geschwindigkeit insbesondere schwerer Werkstücke oder Güter</p> <p>Material Edelstahl</p> <p>Liefereinheit 10 Stück</p> <p>Extras weitere Materialien, weitere Oberflächen auf Anfrage</p> <p>Hinweis passende Rollenelemente R28 siehe Seite 632; passende Rollen R28 siehe Seite 638</p>	<p>Model For rollers R28 in roller tracks ST and AL</p> <p>Description A clip-on for 3 rollers R28; brakes workpieces and goods, in particular heavier ones, smoothly to give them the correct operating speed</p> <p>Material Stainless steel</p> <p>Pack Quantity 10 pieces</p> <p>Specials Other materials, other surfaces on request</p> <p>Tip Compatible roller element R28 see page 632; compatible rollers R28 see page 638</p>
---	---

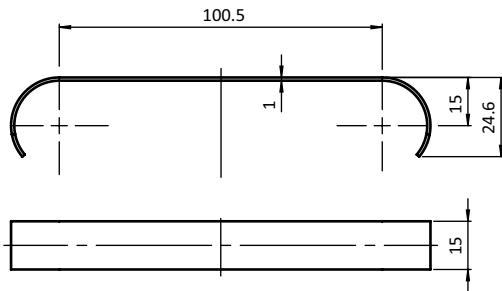

Bremse R28
Brake R28

ESD

Gewicht [g]
Weight [g]

Teil-Nr.
Part #



15.0

062RBR28E



BREMSE H26

BRAKE H26

<p>Ausführung für Rollen H26 in Rollenschienen ST und AL</p> <p>Beschreibung zum Clipsen über 4 Rollen H26; sorgt für ein sanftes Abbremsen und die richtige Anfahr- geschwindigkeit insbesondere schwerer Werkstücke oder Güter</p> <p>Material Edelstahl</p> <p>Liefereinheit 10 Stück</p> <p>Extras weitere Materialien, weitere Oberflächen auf Anfrage</p> <p>Hinweis passende Rollen H26 siehe Seite 639</p>	<p>Model For rollers H26 in roller tracks ST and AL</p> <p>Description A clip-on for 4 rollers H26; brakes workpieces and goods, in particular heavier ones, smoothly to give them the correct operating speed</p> <p>Material Stainless steel</p> <p>Pack Quantity 10 pieces</p> <p>Specials Other materials, other surfaces on request</p> <p>Tip Compatible rollers see page 639</p>
--	---

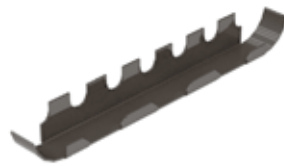
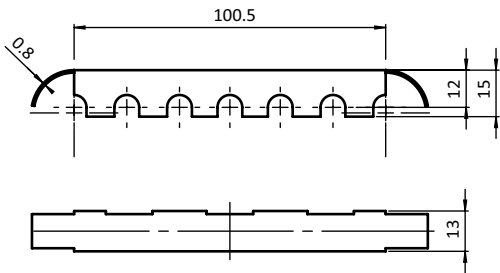

Bremse H26
Brake H26

ESD

Gewicht [g]
Weight [g]

Teil-Nr.
Part #



18.0

062RBH26E



ROLLENELEMENT R9

ROLLER UNIT R9

<p>Ausführung für Rollenschienen AL</p> <p>Beschreibung kompaktes Rollenelement D9 für Rollenschienen-Profil AL, kürzester Achsabstand und maximale Achsanzahl für erschütterungsarmen Lauf und reduzierte Punktbelastung des Gutes; komplett vormontiert</p> <p>Material Standard-Rolle: Kunststoff PA, glaskugelverstärkt Standard-Käfig: Kunststoff PA, glasfaserverstärkt ⚡ elektrostatisch entladende Rolle und Käfig: Kunststoff PA, kohlefaserverstärkt Achse: Stahl</p> <p>Farbe Rolle: schwarz, gelb, rot, grün / grau Käfig: schwarz / grau</p> <p>Liefereinheit 10 Stück</p> <p>Extras farbige Rolle in grauem Käfig, weitere Materialien, weitere Farben auf Anfrage</p> <p>Hinweis Rollenelement R9 bestehend aus: – Rollen R9, siehe Seite 640; – Achse AL, siehe Seite 641; – Käfig für Rollen R9, siehe Seite 644</p>	<p>Model For roller tracks AL</p> <p>Description A compact roller unit R9 for roller tracks AL, very small center distance and maximum number of axles for minimum vibrations and reduced point load on the goods; completely preassembled</p> <p>Material Standard roller: Plastic PA, glass reinforced Standard cage: Plastic PA, glass fiber reinforced ⚡ electrostatically discharging roller and cage: Plastic PA, carbon fiber reinforced Axle: Steel</p> <p>Color Roller: Black, yellow, red, green / gray Cage: Black / gray</p> <p>Pack Quantity 10 pieces</p> <p>Specials Colored rollers in gray cage, other materials, other colors on request</p> <p>Tip Roller unit R9 consisting of: – Rollers R9, see page 640; – Axle AL, see page 641 – Cage for rollers R9, see page 644</p>
--	--

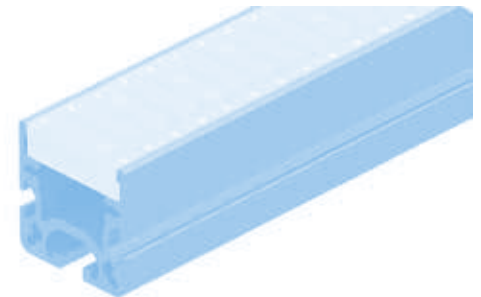
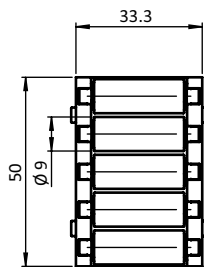
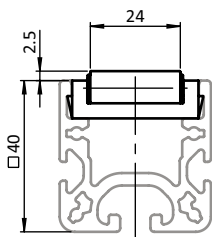

Rollenelement R9 Roller Unit R9	ESD	Farbe Käfig Color of Cage	Farbe Rolle Color of Roller	Tragkraft [N] Max. Load [N]	Gewicht [g] Weight [g]	Teil-Nr. Part #
		schwarz Black	schwarz Black	100	30.0	062AER991.50
	⚡	schwarz Black	schwarz Black	80	28.0	062AER991ESD.50
		schwarz Black	gelb ≈ RAL 1003 Yellow	100	30.0	062AER911.50
		schwarz Black	rot ≈ RAL 3020 Red	100	30.0	062AER931.50
		schwarz Black	grün ≈ RAL 6032 Green	100	30.0	062AER961.50
		grau ≈ RAL 7042 Gray	grau ≈ RAL 7042 Gray	100	30.0	062AER974.50

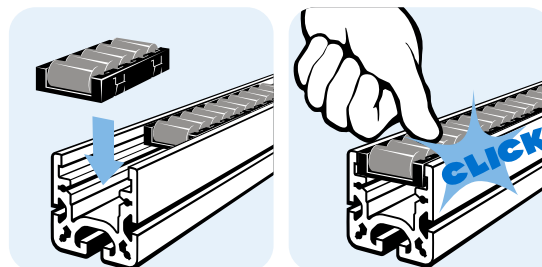



KUGEELEMENT

BALL UNIT

<p>Ausführung für Rollenschienen AL</p> <p>Beschreibung vormontiertes Kugелеlement für Rollenschienen-Profil AL, mit verschleiß- und reibungsarmer Kugelrolle zum flexiblen Bewegen in zwei Dimensionen, z.B. in Weichen oder Schleusen</p> <p>Material Kugel: Edelstahl Kugelgehäuse: Stahl Käfig: Kunststoff PA, kohlefaserverstärkt</p> <p>Farbe Käfig: schwarz</p> <p>Liefereinheit 10 Stück</p> <p>Extras weitere Materialien, weitere Oberflächen auf Anfrage</p> <p>Hinweis Kugелеlement bestehend aus: – Kugелеinsatz D24, siehe Seite 646; – Käfig für Kugелеinsatz D24, siehe Seite 648; passende Gleitleiste AL siehe Seite 616</p>	<p>Model For roller tracks AL</p> <p>Description A preassembled ball unit for roller track profiles AL, with low-wear, low friction ball caster for flexible movements in two directions, for example at track switches and material locks</p> <p>Material Ball: Stainless steel Ball chassis: Steel Cage: Plastic PA, carbon fiber reinforced</p> <p>Color Cage: Black</p> <p>Pack Quantity 10 pieces</p> <p>Specials Other materials, other surfaces on request</p> <p>Tip Brush unit consisting of: – Ball insert, see page 646; – Cage for ball insert, see page 648; compatible slide rail AL see page 616</p>
---	--

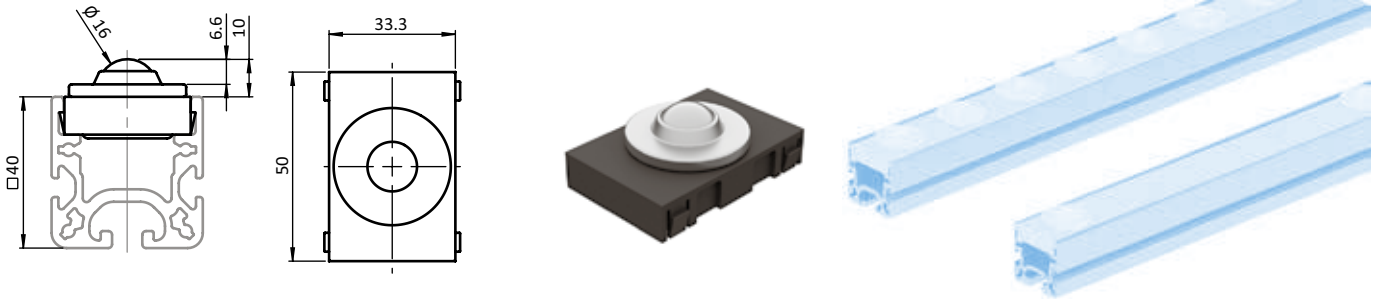

Kugелеlement
Ball Unit

ESD

Gewicht [g]
Weight [g]

Teil-Nr.
Part #



71.0

062AEQE.50

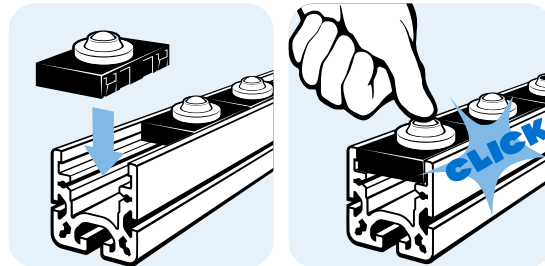



BÜRSTENELEMENT

BRUSH UNIT

<p>Ausführung für Rollenschienen AL</p> <p>Beschreibung vormontiertes Bürstenelement für Rollschienen-Profil AL, mit elastischen Bürstenfasern zum schonenden Gleiten kratzempfindlicher Gegenstände in zwei Dimensionen</p> <p>Material Fasern: Kunststoff PA, ⚡ elektrostatisch entladend Bürstenkopf: Kunststoff PP, ⚡ elektrostatisch entladend Käfig: Kunststoff PA, kohlefaserverstärkt</p> <p>Farbe schwarz</p> <p>Liefereinheit 10 Stück</p> <p>Extras weitere Materialien, weitere Faserhöhen auf Anfrage</p> <p>Hinweis Kugelelement bestehend aus: – Bürsteneinsatz D24, siehe Seite 647; – Käfig für Bürsteneinsatz D24, siehe Seite 648; passende Gleitleiste AL siehe Seite 616</p>	<p>Model For roller tracks AL</p> <p>Description A preassembled brush unit for roller track profiles AL, with elastic brush fibers, allowing a gentle, material-protective sliding of scratch sensitive goods in two directions</p> <p>Material Fibers: Plastic PA, ⚡ electrostatically discharging Brush head: Plastic PP, ⚡ electrostatically discharging Cage: Plastic PA, carbon fiber reinforced</p> <p>Color Black</p> <p>Pack Quantity 10 pieces</p> <p>Specials Other materials, other fiber heights on request</p> <p>Tip Brush unit consisting of: – Brush insert, see page 647; – Cage for brush insert, see page 648; compatible slide rail AL see page 616</p>
--	--

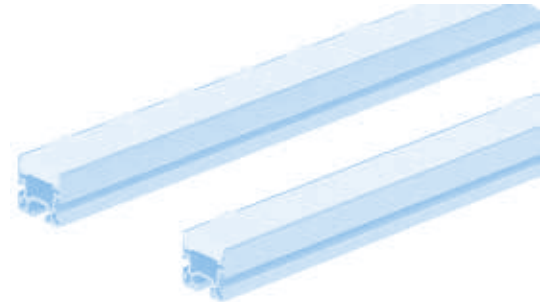
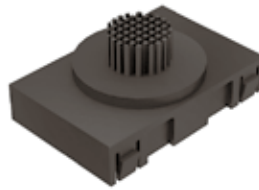
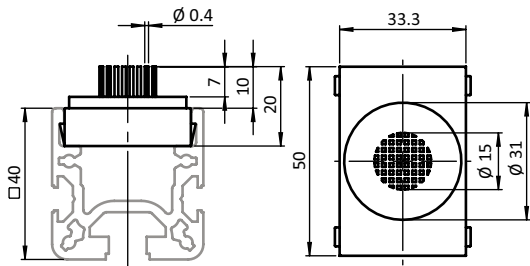

Bürstenelement
Brush Unit

ESD

Gewicht [g]
Weight [g]

Teil-Nr.
Part #



14.0

062AEB91ESD.50

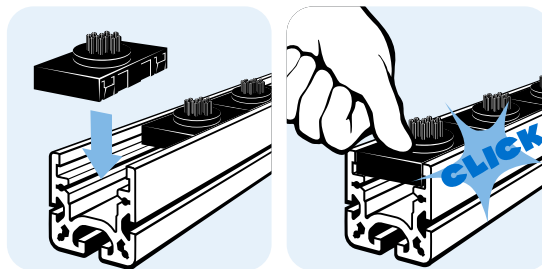



ROLLE R28

ROLLER R28

Ausführung	für Rollenschienen AL	Model	For roller tracks AL
Beschreibung	belastbare und laufruhige Rolle für Rollenschienen AL, wahlweise ohne oder mit Spurkranz als seitliche Führung, schnell austauschbar	Description	A resilient and smooth running roller for roller tracks AL, optionally without or with flange as lateral guiding, quickly replaceable
Material	Standard-Ausführung: Kunststoff PA, glaskugerverstärkt ⚡ elektrostatisch entladende Ausführung: Kunststoff PA, kohlefaserverstärkt	Material	Standard version: Plastic PA, glass ball reinforced ⚡ electrostatically discharging version: Plastic PA, carbon fiber reinforced
Liefereinheit	100 Stück	Pack Quantity	100 pieces
Extras	weitere Materialien, weitere Farben auf Anfrage	Specials	Other materials, other colors on request
Hinweis	passende Achse siehe Seite 641; passender Käfig siehe Seite 642; passende Bremse R28 siehe Seite 633	Tip	Compatible axle see page 641; compatible cage see page 642; compatible brake R 28 see page 633;



Rolle R28 Roller R28	ESD	Farbe Color	Gewicht [g] Weight [g]	Teil-Nr. Part #
ohne Spurkranz Without flange		schwarz Black	9.0	062RR2891
	⚡	schwarz Black	8.0	062RR2891ESD
		gelb ≈ RAL 1003 Yellow	9.0	062RR2811
		rot ≈ RAL 3020 Red	9.0	062RR2831
		grün ≈ RAL 6032 Green	9.0	062RR2861
		grau ≈ RAL 7042 Gray	9.0	062RR2874
mit Spurkranz With flange		schwarz Black	10.0	062RR28F91
	⚡	schwarz Black	9.0	062RR28F91ESD
		gelb ≈ RAL 1003 Yellow	10.0	062RR28F11
		rot ≈ RAL 3020 Red	10.0	062RR28F31
		grün ≈ RAL 6032 Green	10.0	062RR28F61
		grau ≈ RAL 7042 Gray	10.0	062RR28F74



ROLLE H26

ROLLER H26

<p>Ausführung für Rollenschienen AL</p> <p>Beschreibung belastbare und lafruhige Halbrolle für Rollenschienen AL, kurzer Achsabstand durch versetzt nebeneinander laufende Rollen, schnell austauschbar</p> <p>Material Standard-Ausführung: Kunststoff PA, glaskugerverstärkt ⚡ elektrostatisch entladende Ausführung: Kunststoff PA, kohlefaserverstärkt</p> <p>Liefereinheit 100 Stück</p> <p>Extras weitere Materialien, weitere Farben auf Anfrage</p> <p>Hinweis passende Achse siehe Seite 641; passender Käfig siehe Seite 643; passende Bremse siehe Seite 634</p>	<p>Model For roller tracks AL</p> <p>Description A resilient and smooth running half roller for roller tracks AL, short center distance due to staggered roller layout, quickly replaceable</p> <p>Material Standard version: Plastic PA, glass ball reinforced ⚡ electrostatically discharging version: Plastic PA, carbon fiber reinforced</p> <p>Pack Quantity 100 pieces</p> <p>Specials Other materials, other colors on request</p> <p>Tip Compatible axle see page 641; compatible cage see page 643; compatible brake see page 634;</p>
---	---

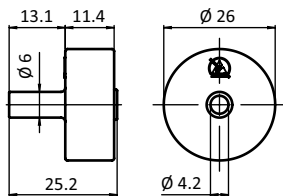

Rolle H26 Roller H26	ESD	Farbe Color	Gewicht [g] Weight [g]	Teil-Nr. Part #
		schwarz <i>Black</i>	5.0	062RH2691
	⚡	schwarz <i>Black</i>	4.0	062RH2691ESD
		gelb ≈ RAL 1003 <i>Yellow</i>	5.0	062RH2611
		rot ≈ RAL 3020 <i>Red</i>	5.0	062RH2631
		grün ≈ RAL 6032 <i>Green</i>	5.0	062RH2661
		grau ≈ RAL 7042 <i>Gray</i>	5.0	062RH2674



ROLLE R9

ROLLER R9

Ausführung	für Rollenschienen AL	Model	For roller tracks AL
Beschreibung	kompakte Rollen D9 für Rollenschienen-Profil AL, kürzester Achsabstand und maximale Achszahl für erschütterungsarmen Lauf und reduzierte Punktbelastung des Gutes, schnell austauschbar	Description	A compact roller for roller tracks AL, very small center distance and maximum number of axles for minimum vibrations and reduced point load on the goods, quickly replaceable
Material	Standard-Ausführung: Kunststoff PA, glaskugerverstärkt ⚡ elektrostatisch entladende Ausführung: Kunststoff PA, kohlefaserverstärkt	Material	Standard version: Plastic PA, glass ball reinforced ⚡ electrostatically discharging version: Plastic PA, carbon fiber reinforced
Liefereinheit	100 Stück	Pack Quantity	100 pieces
Extras	weitere Materialien, weitere Farben auf Anfrage	Specials	Other materials, other colors on request
Hinweis	passende Achse siehe Seite 641; passender Käfig siehe Seite 644	Tip	Compatible axle see page 641; compatible cage see page 644

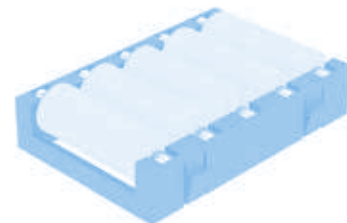
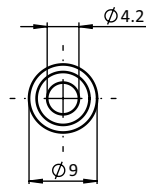
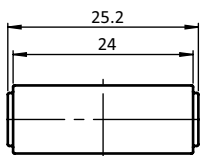

Rolle H9 Roller H9	ESD	Farbe Color	Gewicht [g] Weight [g]	Teil-Nr. Part #
		schwarz <i>Black</i>	1.0	062RR991
	⚡	schwarz <i>Black</i>	0.8	062RR991ESD
		gelb ≈ RAL 1003 <i>Yellow</i>	1.0	062RR911
		rot ≈ RAL 3020 <i>Red</i>	1.0	062RR931
		grün ≈ RAL 6032 <i>Green</i>	1.0	062RR961
		grau ≈ RAL 7042 <i>Gray</i>	1.0	062RR974



ACHSE FÜR ROLLENSCHIENEN AL

AXLE FOR ROLLER TRACKS AL

<p>Ausführung für Rollenschienen AL</p> <p>Beschreibung zum Einsetzen von Rolle R28, Rolle H26 oder Rolle R9 in dazugehörige Käfige für Rollenschienen AL</p> <p>Material Stahl</p> <p>Liefereinheit 100 Stück</p> <p>Extras weitere Materialien, weitere Oberflächen auf Anfrage</p> <p>Hinweis passende Rollen siehe Seite 638, Seite 639, Seite 640; passende Käfige siehe Seite 642, Seite 643, Seite 644</p>	<p>Model For roller tracks AL</p> <p>Description To insert roller R28, roller H26, or roller R9 into the suitable cages for roller tracks AL</p> <p>Material Steel</p> <p>Pack Quantity 100 pieces</p> <p>Specials Other materials, other surfaces on request</p> <p>Tip Compatible rollers see page 638, page 639, page 640; compatible cages see page 642, page 643, page 644</p>
---	---

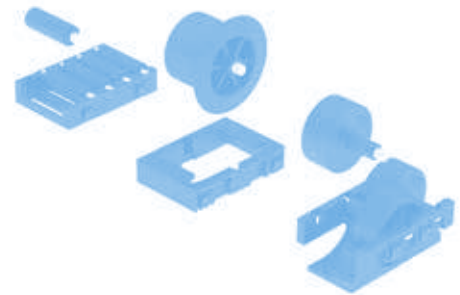
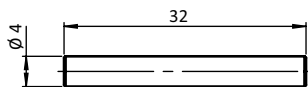

Achse für Rollenschienen AL
Axle for roller tracks AL

ESD

Gewicht [g]
Weight [g]

Teil-Nr.
Part #



3.0

062AXM



KÄFIG FÜR ROLLEN R28

CAGE FOR ROLLERS R28

Ausführung	für Rollenschienen AL	Model	For roller tracks AL
Beschreibung	robuster Käfig für Rollenschienen-Profile AL, zur Aufnahme einer Rolle R28 mittels Achse; Käfig L50 auch für Rolle R28 mit Spurkranz geeignet	Description	A sturdy cage for roller track profiles AL, to support a roller R28 by means of an axle; cage L50 also suitable for roller R28 with flange
Material	Standard-Ausführung: Kunststoff PA, glasfaserverstärkt ⚡ elektrostatisch entladende Ausführung: Kunststoff PA, kohlefaserverstärkt	Material	Standard version: Plastic PA, glass fiber reinforced ⚡ electrostatically discharging version: Plastic PA, carbon fiber reinforced
Farbe	schwarz, grau	Color	Black, gray
Liefereinheit	100 Stück	Pack Quantity	100 pieces
Extras	weitere Materialien, weitere Farben auf Anfrage	Specials	Other materials, other colors on request
Hinweis	passende Rollen R28 siehe Seite 638; passende Achse AL siehe Seite 641	Tip	Compatible rollers see page 638; compatible axle see page 641

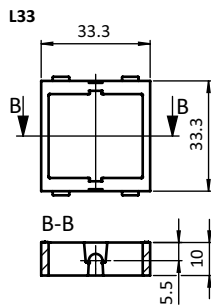
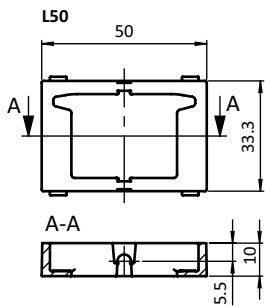

Käfig für Rollen R28 <i>Cage for Rollers R28</i>	ESD	Farbe <i>Color</i>	Gewicht [g] <i>Weight [g]</i>	Teil-Nr. <i>Part #</i>
L50		schwarz <i>Black</i>	7.0	062ACR2891.50
	⚡	schwarz <i>Black</i>	5.5	062ACR2891ESD.50
		grau ≈ RAL 7042 <i>Gray</i>	7.0	062ACR2874.50
L33		schwarz <i>Black</i>	5.0	062ACR2891.33
	⚡	schwarz <i>Black</i>	4.0	062ACR2891ESD.33
		grau ≈ RAL 7042 <i>Gray</i>	5.0	062ACR2874.33



KÄFIG FÜR ROLLEN H26

CAGE FOR ROLLERS H26

Ausführung	für Rollenschienen AL	Model	For roller tracks AL
Beschreibung	robuster Käfig für Rollenschienen-Profile AL, zur Aufnahme von 3 Rollen H26 mittels Achsen; das Endstück schließt den Käfig am Schienenende ab	Description	A sturdy cage for roller track profiles AL, to support 3 rollers H26 by means of axles; the end piece provides a neat finish at the end of the profile
Material	Standard-Ausführung: Kunststoff PA, glasfaserverstärkt ⚡ elektrostatisch entladende Ausführung: Kunststoff PA, kohlefaserverstärkt	Material	Standard version: Plastic PA, glass fiber reinforced ⚡ electrostatically discharging version: Plastic PA, carbon fiber reinforced
Liefereinheit	100 Stück	Pack Quantity	100 pieces
Extras	weitere Materialien, weitere Farben auf Anfrage	Specials	Other materials, other colors on request
Hinweis	passende Rollen H26 siehe Seite 639; passende Achse AL siehe Seite 641	Tip	Compatible rollers see page 639; compatible axle see page 641

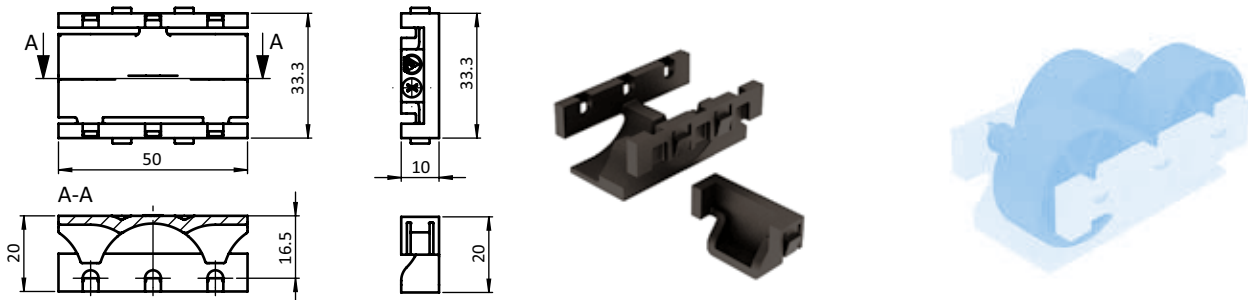

Käfig für Rollen H26 <i>Cage for Rollers H26</i>	ESD	Farbe <i>Color</i>	Gewicht [g] <i>Weight [g]</i>	Teil-Nr. <i>Part #</i>
Käfig <i>Cage</i>		schwarz <i>Black</i>	11.0	062ACH2691.50
	⚡	schwarz <i>Black</i>	9.4	062ACH2691ESD.50
		grau ≈ RAL 7042 <i>Gray</i>	11.0	062ACH2674.50
Endstück <i>End piece</i>		schwarz <i>Black</i>	5.0	062ACEH2691.10
	⚡	schwarz <i>Black</i>	4.0	062ACEH2691ESD.10
		grau ≈ RAL 7042 <i>Gray</i>	5.0	062ACEH2674.10



KÄFIG FÜR ROLLEN R9

CAGE FOR ROLLERS R9

Ausführung	für Rollenschienen AL	Model	For roller tracks AL
Beschreibung	robuster Käfig für Rollenschienen-Profil AL, zur Aufnahme von 5 Rollen R9 mittels Achsen	Description	A sturdy cage for roller track profiles AL, to support 5 rollers R9 by means of axles
Material	Standard-Ausführung: Kunststoff PA, glasfaserverstärkt ⚡ elektrostatisch entladende Ausführung: Kunststoff PA, kohlefaserverstärkt	Material	Standard version: Plastic PA, glass fiber reinforced ⚡ electrostatically discharging version: Plastic PA, carbon fiber reinforced
Liefereinheit	100 Stück	Pack Quantity	100 pieces
Extras	weitere Materialien, weitere Farben auf Anfrage	Specials	Other materials, other colors on request
Hinweis	passende Rollen R9 siehe Seite 640; passende Achse AL siehe Seite 641	Tip	Compatible rollers see page 640; compatible axle see page 641

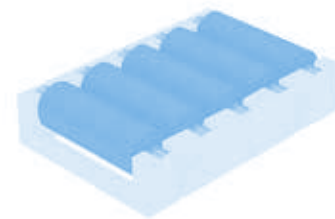
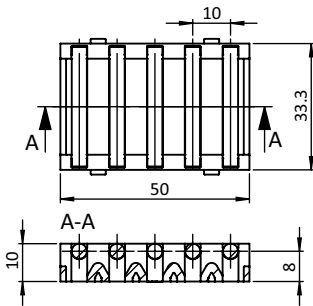

Käfig für Rollen R9 <i>Cage for Rollers R9</i>	ESD	Farbe <i>Color</i>	Gewicht [g] <i>Weight [g]</i>	Teil-Nr. <i>Part #</i>
		schwarz <i>Black</i>	10.0	062ACR991.50
	⚡	schwarz <i>Black</i>	9.0	062ACR991ESD.50
		grau ≈ RAL 7042 <i>Gray</i>	10.0	062ACR974.50



DISTANZSTÜCK L25 FÜR ROLLENKÄFIG AL

SPACER L25 FOR ROLLER CAGE AL

<p>Ausführung für Rollenschienen AL</p> <p>Beschreibung als Abstandsstück zwischen Rollen-, Bürsten- oder Kugelelementen z.B. zur versetzten Anordnung; sowie zum Schließen von Lücken, wenn die Länge des Rollenschienen-Profiles AL nicht einem Vielfachen der Länge des Rollenkäfigs / -elements entspricht</p> <p>Material Kunststoff PA, glasfaserverstärkt</p> <p>Farbe schwarz</p> <p>Liefereinheit 100 Stück</p> <p>Extras weitere Materialien, weitere Farben auf Anfrage</p>	<p>Model For roller tracks AL</p> <p>Description As spacer between roller, brush or ball units for example to build staggered formations; as well as to fill gaps, in case the length of the roller track profile AL does not match with a multiple of the length of the roller cages / elements</p> <p>Material Plastics PA, glass fiber reinforced</p> <p>Color Black</p> <p>Pack Quantity 100 pieces</p> <p>Specials Other materials, other colors on request</p>
--	--

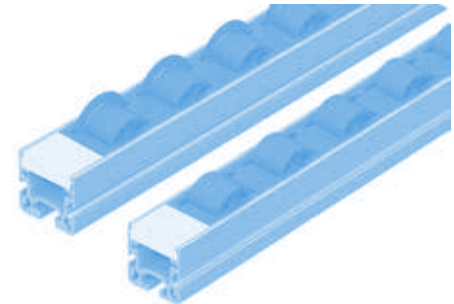
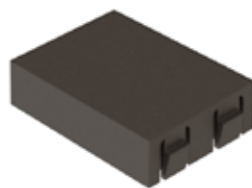
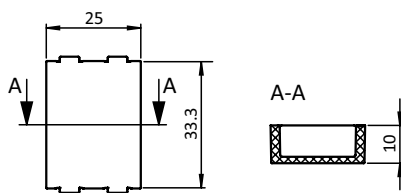

Distanzstück L25 für Rollenkäfig AL
Spacer L25 for Roller Cage AL

Gewicht [g]
Weight [g]

4.0

Teil-Nr.
Part #

062ACS91.25



KUGELEINSATZ D24

BALL INSERT D24

<p>Ausführung für Rollenschienen AL</p> <p>Beschreibung verschleiß- und reibungsarme Kugelrolle zum flexiblen Bewegen in zwei Dimensionen, z.B. in Weichen oder Schleusen; für Rollenschienen AL, kann auch in Flächenelemente eingesetzt werden, z.B. in Tischplatten</p> <p>Material Kugel: Edelstahl Gehäuse: Stahl</p> <p>Liefereinheit 10 Stück</p> <p>Extras weitere Materialien, weitere Oberflächen auf Anfrage</p> <p>Hinweis passender Käfig für Kugeleinsatz D24 siehe Seite 648</p>	<p>Model For roller tracks AL</p> <p>Description A low-wear, low friction ball caster for flexible movements in two directions, for example at track switches and material locks; for roller tracks AL, can also be used in panels, e.g. on table tops</p> <p>Material Ball: Stainless steel Chassis: Steel</p> <p>Pack Quantity 10 pieces</p> <p>Specials Other materials, other surfaces on request</p> <p>Tip Compatible cage for the ball insert see page 648</p>
---	---

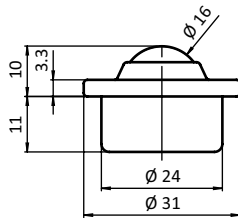

Kugeleinsatz D24
Ball Insert D24

ESD

Tragkraft [N]
Max. Load [N]

Gewicht [g]
Weight [g]

Teil-Nr.
Part #

	600	63.0	062AQE
--	-----	------	---------------



BÜRSTENEINSATZ D24

BRUSH INSERT D24

<p>Ausführung für Rollenschienen AL</p> <p>Beschreibung elastische Bürstenfasern zum schonenden Gleiten kratzempfindlicher Gegenstände in zwei Dimensionen; für Rollenschienen AL, kann auch in Flächenelemente z.B. von Tischflächen eingesetzt werden</p> <p>Material Fasern: Kunststoff PA, ⚡ elektrostatisch entladend Bürstenkopf: Kunststoff PP, ⚡ elektrostatisch entladend</p> <p>Farbe Fasern: schwarz Bürstenkopf: schwarz</p> <p>Liefereinheit 10 Stück</p> <p>Extras weitere Materialien, weitere Faserhöhen auf Anfrage</p> <p>Hinweis passender Käfig für Kugeleinsatz D24 siehe Seite 648</p>	<p>Model For roller tracks AL</p> <p>Description With elastic brush fibers, allowing a gentle, material-protective sliding of scratch sensitive goods in two directions; for roller tracks AL, can also be used in panels, e.g. on table surfaces</p> <p>Material Fibers: Plastic PA, ⚡ electrostatically discharging Brush head: Plastic PP, ⚡ electrostatically discharging</p> <p>Color Fibers: Black Brush head: Black</p> <p>Pack Quantity 10 pieces</p> <p>Specials Other materials, other fiber heights on request</p> <p>Tip Compatible cage for the ball insert see page 648</p>
---	--

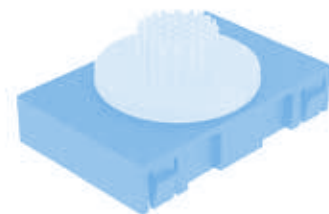
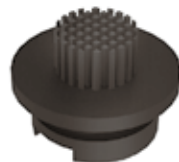
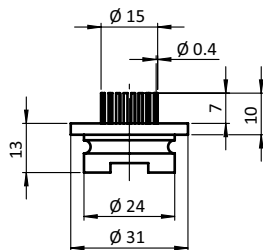

Kugeleinsatz D24
Ball Insert D24

ESD

Gewicht [g]
Weight [g]

Teil-Nr.
Part #



6.0

062ABKESD



KÄFIG FÜR KUGEL- / BÜRSTENEINSATZ D24

CAGE FOR BALL / BRUSH INSERT D24

<p>Ausführung für Rollenschienen AL</p> <p>Beschreibung robuster Käfig für Rollschienen-Profile AL, zur Aufnahme eines Kugel- oder Bürsteneinsatzes D24</p> <p>Material Kunststoff PA, kohlefaserverstärkt</p> <p>Farbe schwarz</p> <p>Liefereinheit 10 Stück</p> <p>Extras weitere Materialien, weitere Farben auf Anfrage</p> <p>Hinweis passender Kugeleinsatz D24 siehe Seite 646; passender Bürsteneinsatz D24 siehe Seite 647</p>	<p>Model For roller tracks AL</p> <p>Description A sturdy cage for roller track profiles AL, to support a D24 ball or brush insert</p> <p>Material Plastic PA, carbon fiber reinforced</p> <p>Color Black</p> <p>Pack Quantity 10 pieces</p> <p>Specials Other materials, other colors on request</p> <p>Tip Compatible ball insert see page 646; Compatible brush insert see page 647</p>
--	---

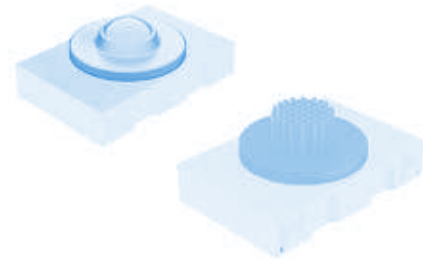
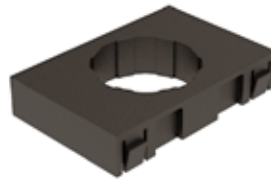
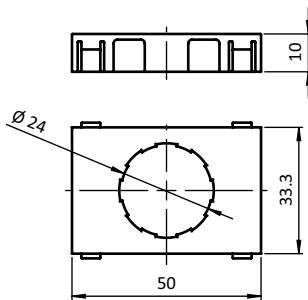

Käfig für Kugel-/Bürsteneinsatz D24
Cage for Ball / Brush Insert D24

ESD

Gewicht [g]
Weight [g]

Teil-Nr.
Part #



8.0

062ACD2491ESD.50

ANSCHLAGPUFFER

STOP BUFFER

Ausführung	in zylindrischer Form	Model	With cylindrical shape
Beschreibung	zum Dämpfen des Aufpralls von Türen, Klappen und Abdeckungen	Description	End-position damping of doors, flaps and covers
Material	Puffer: Gummi Naturkautschuk (NR), ≈55 Shore A Gewindestück: Stahl	Material	Buffer: Natural rubber (NR), ≈55 Shore A Threaded bolt: Steel
Liefereinheit	20 Stück	Pack Quantity	20 pieces

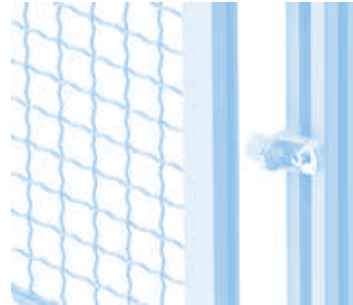
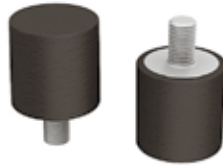
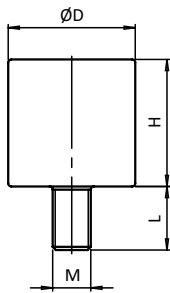

Anschlagpuffer <i>Stop Buffer</i>	D [mm]	H [mm]	L [mm]	Gewinde <i>Thread</i>	Gewicht [g] <i>Weight [g]</i>	Teil-Nr. <i>Part #</i>
	20.0	15.0	10.0	M6	11.0	051DC551520MM0610
	20.0	20.0	10.0	M6	13.0	051DC552020MM0610

ANSCHLAGPUFFER

STOP BUFFER

Ausführung	mit parabolischem Querschnitt	Model	With parabolic cross-section
Beschreibung	zum Dämpfen des Aufpralls von Türen, Klappen und Abdeckungen	Description	End-position damping of doors, flaps and covers
Material	Puffer: Gummi Naturkautschuk (NR), ≈55 Shore A Gewindestück: Stahl	Material	Buffer: Natural rubber (NR), ≈55 Shore A Threaded bolt: Steel
Liefereinheit	20 Stück	Pack Quantity	20 pieces

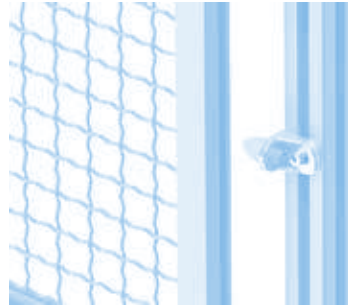
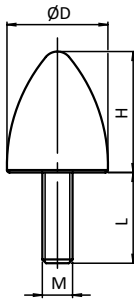

Anschlagpuffer <i>Stop Buffer</i>	D [mm]	H [mm]	L [mm]	Gewinde <i>Thread</i>	Gewicht [g] <i>Weight [g]</i>	Teil-Nr. <i>Part #</i>
	20.0	24.0	18.0	M6	12.5	051DKP552420MM0618

ANSCHLAGPUFFER

BUFFER STOP

Ausführung	in zylindrischer Form, mit Innengewinde	Model	With cylindrical shape, with internal thread
Beschreibung	zum Dämpfen des Endanschlags von Türen, Klappen, Abdeckungen, Werkstücken oder Gütern	Description	End-position damping of doors, flaps, covers working pieces and goods
Material	Puffer: Gummi NBR, ≈ 55 Shore A Gewindestück: Stahl	Material	Buffer: Rubber NBR, ≈ 55 Shore A Threaded insert: Steel
Liefereinheit	20 Stück	Pack Quantity	20 pieces
Hinweis	passende Abschlussplatte AL siehe Seite 629	Tip	Compatible end plate AL see page 629

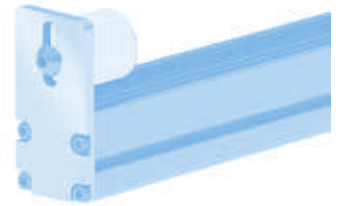
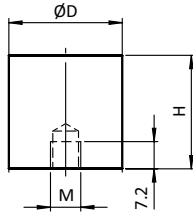

Anschlagpuffer <i>Stop Buffer</i>	D [mm]	H [mm]	Gewinde <i>Thread</i>	Gewicht [g] <i>Weight [g]</i>	Teil-Nr. <i>Part #</i>
	30.0	30.0	M8	38.0	051DC55303FM08



ROLLENHALTER

ROLLER MOUNTING BLOCK

<p>Ausführung Kunststoff PA, ab Profil 30</p> <p>Beschreibung zur Montage von Laufrollen an Aluminiumprofilen; ermöglicht den Austausch einzelner Rollen ohne Demontage der Profilstruktur; durch einfaches Umdrehen sowohl für Nut 8 als auch für Nut 10 verwendbar</p> <p>Material Kunststoff PA, glasfaserverstärkt</p> <p>Farbe schwarz</p> <p>Liefereinheit 100 Stück</p> <p>Extras weitere Farben auf Anfrage</p>	<p>Model Plastic PA, profile 30 and up</p> <p>Description To mount track rollers on aluminum profiles; individual rollers can be replaced without dismantling the entire system; can be used for slot 8 and slot 10 by simply turning it</p> <p>Material Plastic PA, glass fiber reinforced</p> <p>Color Black</p> <p>Pack Quantity 100 pieces</p> <p>Specials Other colors on request</p>
---	--

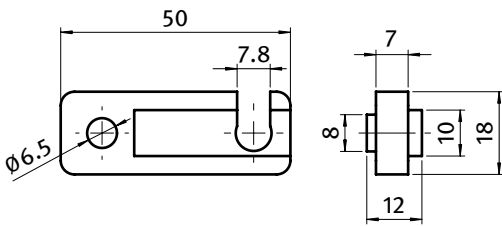

Rollenhalter Roller Mounting Block	ESD	N	Gewicht [g] Weight [g]	Teil-Nr. Part #
		8 / 10	8.2	093200
		8 / 10	7.1	093200S01



SENSORHALTER

SENSOR MOUNTING BLOCK

Ausführung	Kunststoff PA	Model	Plastic PA
Beschreibung	zur variablen Befestigung von Wegschaltern an Aluminiumprofilen	Description	To attach sensors to the aluminum profile in an adjustable position
Material	Kunststoff PA, glasfaserverstärkt	Material	Plastic PA, glass fiber reinforced
Farbe	schwarz	Color	Black
Liefereinheit	100 Stück	Pack Quantity	100 pieces
Extras	☁ elektrostatisch entladend, weitere Größen, weitere Farben auf Anfrage	Specials	☁ electrostatically discharging, other sizes, other colors on request
Hinweis	Bei Bestellung bitte die Teil-Nr. des gewünschten Fixierstücks und die des Sensorhalters angeben!	Tip	When ordering, please mention the Part # of the fastener as well as that of the sensor mounting block.

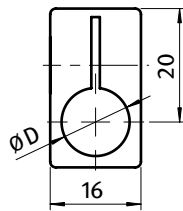
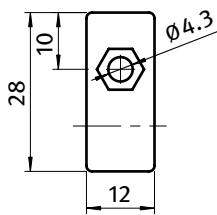

Sensorhalter Sensor Mounting Block	N	Ø D [mm]	Gewicht [g] Weight [g]	Teil-Nr. Part #
Sensorhalter		6.5	5.0	093212
Sensor mounting block		8.0	4.5	093213
		12.0	4.0	093214
Fixierstück <i>Fastener</i>	5		0.3	093215
	6		0.3	093216
	8		0.3	093217
	10		0.5	093218

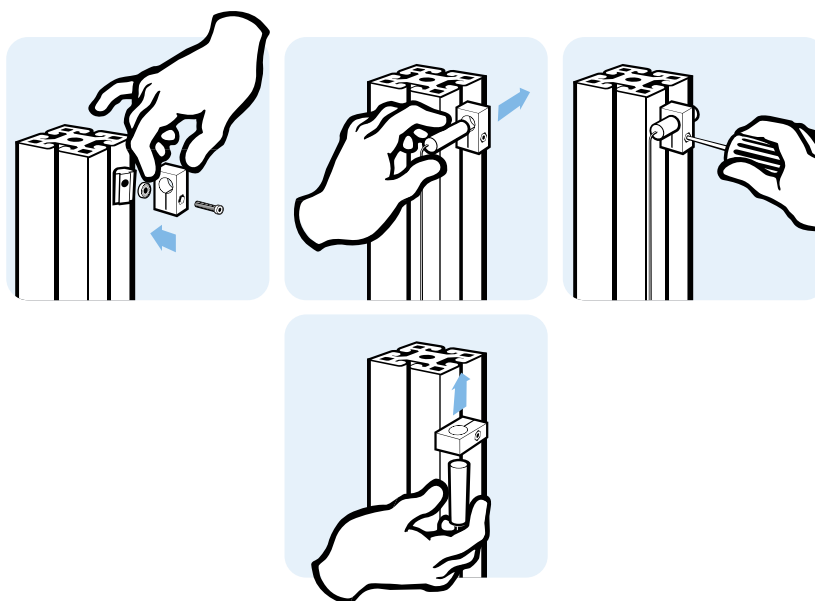



SET RÜCKLAUFSPERRE

SET BACKLOCK

<p>Ausführung Zinkdruckguss</p> <p>Beschreibung zur Verhinderung des Rückfahrens des Werkzeugträgers</p> <p>Material Gehäuse: Zinkdruckguss Sperrklinke: Kunststoff PA / Edelstahl / Messing</p> <p>Set 1 Rücklaufsperrre, 1 Hammermutter Nut 10 M8, Stahl verzinkt, 1 Zylinderschraube DIN 912 M8 × 50, Stahl verzinkt, 1 Scheibe 8-FSt</p> <p>Liefereinheit 1 Stück</p>	<p>Model Zinc die-cast</p> <p>Description For preventing backwards movement of tool carrier</p> <p>Material Housing: Zinc die-cast Catch: Plastic PA / stainless steel / brass</p> <p>Set 1 backlock, 1 hammer nut slot 10 M8, zinc-plated steel, 1 cylinder head screw DIN 912 M8 × 50, zincplated steel, 1 washer 8-FSt</p> <p>Pack Quantity 1 piece</p>
--	---

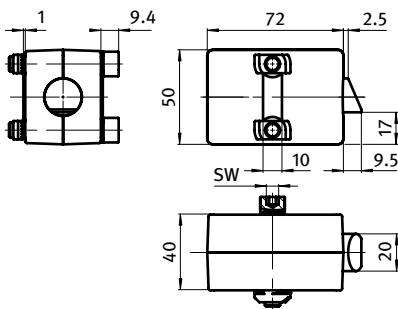

Set Rücklaufsperrre Set Backlock	N	Gewicht [g] Weight [g]	Teil-Nr. Part #
Sperrklinke Kunststoff PA <i>Catch: plastic PA</i>	10	447.0	093100K
Sperrklinke Messing <i>Catch: brass</i>	10	560.0	093100M
Sperrklinke Edelstahl <i>Catch: stainless steel</i>	10	560.0	093100E



RÜCKLAUFSPERRELEMENT

BACKSTOP UNIT

<p>Ausführung für Rollenschienen AL</p> <p>Beschreibung vormontiertes Rücklaufsperrerelement für Rollenschienen-Profil AL, verhindert Rückwärtsbewegung von Gütern auf der Rollenschiene AL</p> <p>Material Rücklaufsperrerelement: Stahl Achse: Stahl Käfig: Kunststoff PA, kohlefaserverstärkt</p> <p>Farbe Käfig: schwarz</p> <p>Liefereinheit 10 Stück</p> <p>Extras weitere Materialien, weitere Oberflächen, weitere Farben auf Anfrage</p>	<p>Model For roller tracks AL</p> <p>Description A preassembled backstop unit for roller track profiles AL, prevents goods from moving backwards on the roller track profile AL</p> <p>Material Backstop: Steel Axle: Steel Cage: Plastic PA, carbon fiber reinforced</p> <p>Color Cage: Black</p> <p>Pack Quantity 10 pieces</p> <p>Specials Other materials, other surfaces, other colors on request</p>
---	--

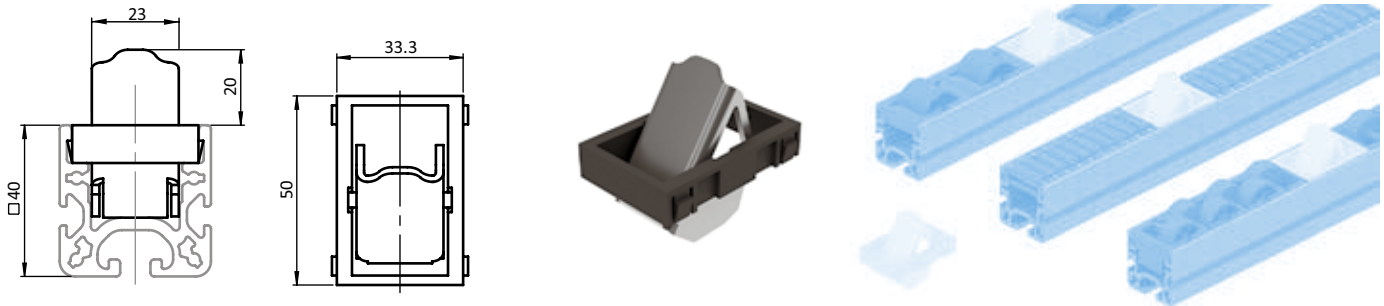

Rücklaufsperrerelement <i>Back Stop Unit</i>	ESD	Gewicht [g] <i>Weight [g]</i>	Teil-Nr. <i>Part #</i>
	elektrostatisch entladend <i>electrostatically discharging</i>	44.0	062AEVMESD.50

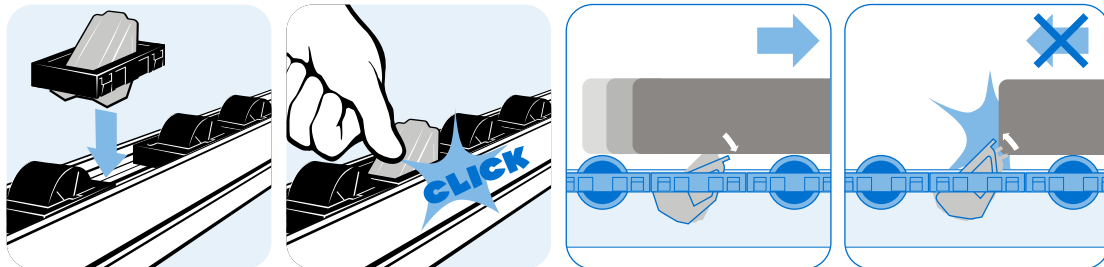



RÜCKLAUFSPERRE ST

BACKSTOP ST

Ausführung	für Rollenschienen ST	Model	For roller tracks ST
Beschreibung	zur Montage in Rollenschienen-Profil ST, verhindert Rückwärtsbewegungen von Gütern auf der Rollenschiene ST	Description	For use in roller track profiles ST, prevents goods from moving backwards on the roller track profile ST
Material	Rücklaufsperrre: Stahl Achse: Stahl	Material	Backstop: Steel Axle: Steel
Liefereinheit	10 Stück	Pack Quantity	10 pieces
Extras	weitere Materialien, weitere Oberflächen auf Anfrage	Specials	Other materials, other surfaces on request

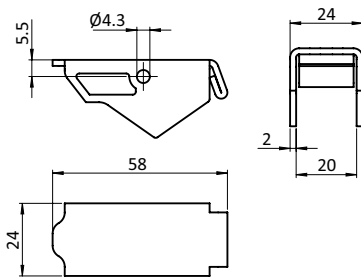

Rücklaufsperrre ST
Back Stop ST

Gewicht [g]
Weight [g]

Teil-Nr.
Part #

37.0

062MVM

INHALTSÜBERSICHT *CONTENT OVERVIEW*

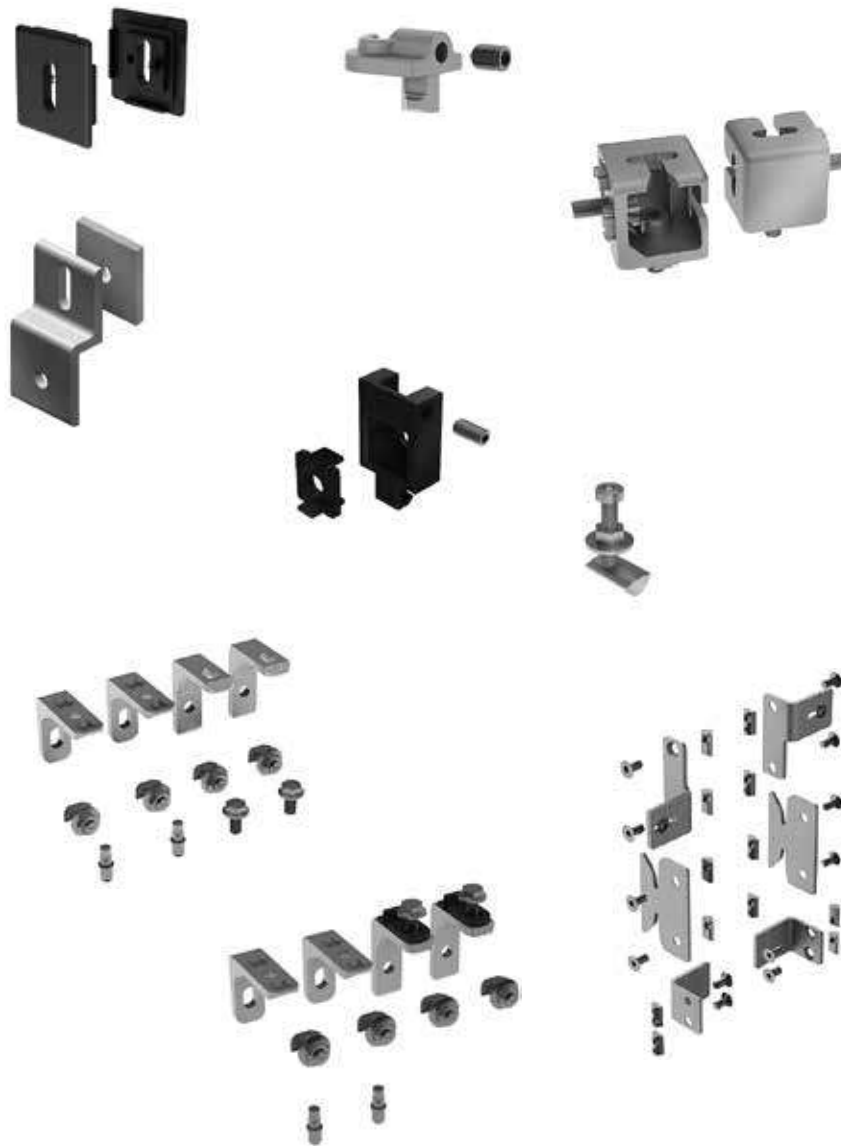

Bodenelemente <i>Floor Elements</i>	1
Scharniere <i>Hinges</i>	2
Nutmuttern und -schrauben <i>T-Nuts and T-Bolts</i>	3
Verbindungstechnik <i>Connecting Systems</i>	4
Griffe und Verschlüsse <i>Handles and Latches</i>	5
Arbeitsplatzkomponenten <i>Components for Work Stations</i>	6
Gleiter und Rollen <i>Sliders and Rollers</i>	7
Fördertechnik <i>Conveyors</i>	8
Schutz- und Trennwandelemente <i>Enclosures, Guards, Partitions</i>	9
Flächenbefestigungen <i>Panel Fasteners</i>	10
Abdeckelemente <i>Cover Elements</i>	11
Kabelführungen <i>Cable Management</i>	12
Diverse Komponenten <i>Miscellaneous Components</i>	13
Rundrohrkomponenten <i>Tubular Frame Components</i>	14



	Klemmplatte für Wellengitter	<i>Wire Mesh Clamping Plate</i>	659
	Schutzgitterklemme	<i>Wire Mesh Clamp</i>	660
	Gitterhalter	<i>Wire Mesh Panel Holder</i>	661
	Klemmprofilverbinder 40 (Set)	<i>Clamp Profile Connector 40 (Set)</i>	662
	Aufhängung für Klemmprofilverbinder 40 (Set)	<i>Mounting for Clamp Profile Connector 40 (Set)</i>	663
	Set Einhängewinkel	<i>Set Suspension Bracket</i>	664
	Sicherheitsaufhängung 8/8 (Set)	<i>Safety Hanger 8/8 (Set)</i>	665
	Set Einhängewinkel CS	<i>Set Suspension Bracket CS</i>	666
	Aufhängung 6-8	<i>Hanger 6-8</i>	667

KLEMMPLATTE FÜR WELLENGITTER

WIRE MESH CLAMPING PLATE

<p>Ausführung Kunststoff PA</p> <p>Beschreibung zum Befestigen von Handgriffen, Warnschildern oder Informationstafeln an Wellengittern 40 x 40 x 4 mm und 30 x 30 x 3 mm, z.B. vorderseitig mit Schraube und rückseitig mit Flanschnutter und Scheibe</p> <p>Material Kunststoff PA, glaskugelverstärkt</p> <p>Farbe schwarz</p> <p>Liefereinheit 10 Stück</p> <p>Extras weitere Farben auf Anfrage</p> <p>Hinweis * Bitte beachten: Sie benötigen jeweils zwei Stück 093048!</p>	<p>Model Plastic PA</p> <p>Description To attach handles, warning signs or information boards to woven wire mesh 40 x 40 x 4 and 30 x 30 x 3, e.g. form the front with screw and from the back with flange nut and shim</p> <p>Material Plastic PA, glass ball reinforced</p> <p>Color Black</p> <p>Pack Quantity 10 pieces</p> <p>Specials Other colors on request</p> <p>Tip * Please note: You need each two pieces 093048!</p>
--	---

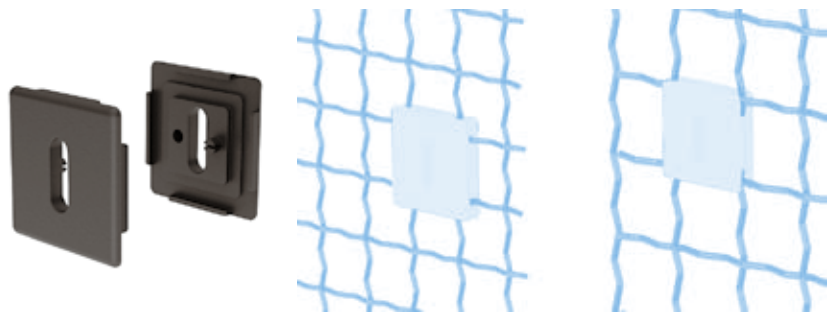
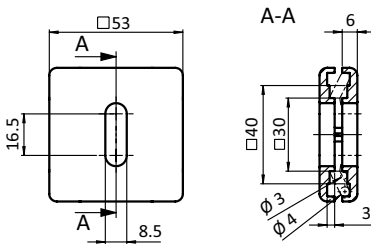

Klemmplatte für Wellengitter
Wire Mesh Clamping Plate

Gewicht [g]
Weight [g]

Teil-Nr.
Part #

14.0

* 093048



SCHUTZGITTERKLEMME

WIRE MESH CLAMP

<p>Ausführung Zinkdruckguss, Nut 8, 10</p> <p>Beschreibung zum Fixieren und Befestigen von Schutzgittern, Klemmweite 3 bis 5 mm (gerade Gitter bis 5 mm, Wellgitter bis 4 mm), montierbar in Profilen mit Nut 8 und Nut 10</p> <p>Material Zinkdruckguss</p> <p>Liefereinheit 10 Stück</p> <p>Extras weitere Oberflächen, weitere Farben auf Anfrage</p>	<p>Model Zinc die-cast, slot 8, 10</p> <p>Description To fix protective wire mesh panels, clamping range 3 up to 5 mm (straight grate up to 5 mm, wave grate up to 4 mm), can be assembled on profiles with slot 8 and slot 10</p> <p>Material Zinc die-cast</p> <p>Pack Quantity 10 pieces</p> <p>Specials Other surfaces, other colors on request</p>
---	--

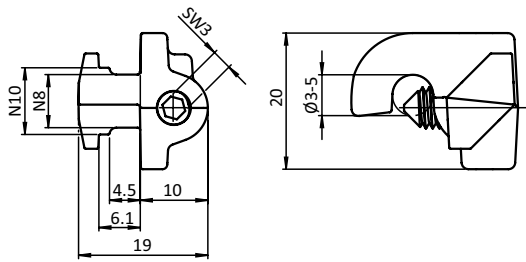

Schutzgitterklemme
Wire Mesh Clamp

Gewicht [g]
Weight [g]

Teil-Nr.
Part #

20.0

093CWM35N0810

GITTERHALTER

WIRE MESH PANEL HOLDER

Ausführung	Aluminium, mit Halteplatte	Model	Aluminum, with backing plate
Beschreibung	zur einfachen Befestigung von Flächenelementen an Aluminiumprofilen	Description	To attach panels easily to aluminum profiles
Material	Aluminium	Material	Aluminum
Liefereinheit	10 Stück	Pack Quantity	10 pieces

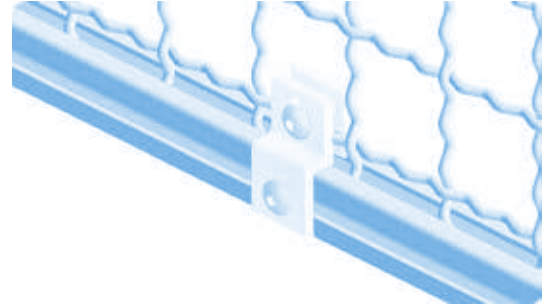
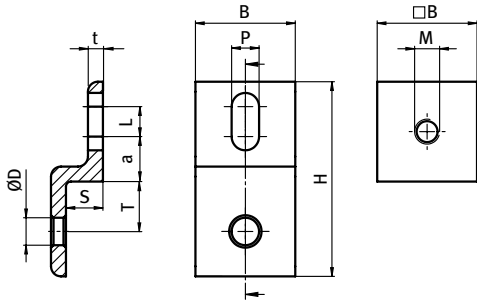

Gitterhalter Wire Mesh Panel Holder	B [mm]	H [mm]	L [mm]	M	P/D [mm]	S [mm]	T [mm]	für Profil For Profile	Gewicht [g] Weight [g]	Teil-Nr. Part #
	20.0	39.0	6.0	M5	5.5	7.4	10.0	20	14.5	093P20LN
	30.0	68.0	10.0	M8	9.0	11.0	15.0	30	41.4	093P30LN
	40.0	78.0	13.5	M8	9.0	16.0	20.0	40	82.0	093P40LN
	45.0	88.0	18.0	M8	9.0	17.5	22.5	45	105.0	093P45LN



KLEMMPROFILVERBINDER 40 (SET)

CLAMP PROFILE CONNECTOR 40 (SET)

<p>Ausführung Zinkdruckguss, Profil 40</p> <p>Beschreibung zur rechtwinkligen Verbindung von zwei Aluminiumprofilen und zum Einhängen eines Rahmenelementes in eine Rahmenkonstruktion mittels geeigneter Aufhängung; obere Aufhängung definiert die Position, Verriegelung erfolgt durch nachträgliches Verschieben der unteren Aufhängung</p> <p>Material Klemmprofilverbinder: Zinkdruckguss Schrauben: Stahl</p> <p>Farbe Klemmprofilverbinder: alufarbig</p> <p>Set 1 Klemmprofilverbinder, 2 Schrauben DIN 912 - M8 x 20</p> <p>Liefereinheit 10 Stück</p> <p>Hinweis passende Aufhängung für Klemmprofilverbinder 40 (Set) siehe Seite 663</p>	<p>Model Zinc die-cast, profile 40</p> <p>Description To connect two aluminum profiles at right angles and to attach a frame element to a frame structure by means of a suitable mounting; the upper mounting defines the position in the structure, by shifting the lower mounting afterwards the frame can be fixed and locked</p> <p>Material Clamp profile connector: Zinc die-cast Screws: Steel</p> <p>Color Clamp profile connector: Alu color</p> <p>Set 1 clamp profile connector, 2 screws DIN 912 - M8 x 20</p> <p>Pack Quantity 10 pieces</p> <p>Tip Compatible mounting for clamp profile connector 40 (Set) see page 663</p>
--	---

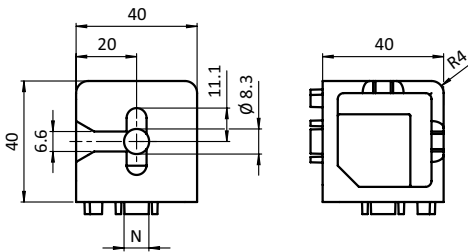

Klemmprofilverbinder 40 (Set)
 Clamp Profile Connector 40 (Set)

Gewicht [g]
 Weight [g]

Profil
 Profile

Teil-Nr.
 Part #

	201.0	I	093WWC401N08S01
--	-------	---	------------------------



AUFHÄNGUNG FÜR KLEMMPROFILVERBINDER 40 (SET) MOUNTING FOR CLAMP PROFILE CONNECTOR 40 (SET)

<p>Ausführung Stahl, Nut 8</p> <p>Beschreibung zum Einhängen von Rahmenelementen mit Klemmprofilverbinder 40; Aufhängung komplett vormontiert, zum seitlichen Einschieben in die Profilvernut, Fixierung durch Mutter; obere Aufhängung definiert die Position, Verriegelung erfolgt durch nachträgliches Verschieben der unteren Aufhängung; 12 mm Spaltmaß zwischen Rahmenelement und Ständerprofilen wobei Maßtoleranzen von +/- 3 mm ausglich werden können</p> <p>Material Nutstein: Stahl Scheibe: Stahl Mutter: Stahl Schraube: Stahl Kugel: Edelstahl</p> <p>Set Aufhängung komplett vormontiert: 1 Nutstein - Nut 8 - M6, 1 Scheibe DIN 9021 - 6,4, 1 Mutter DIN 934 - M6, 1 Schraube DIN 7984 - M6 x 30, 1 Kugel Ø4</p> <p>Liefereinheit 10 Stück</p> <p>Hinweis passender Klemmprofilverbinder 40 (Set) siehe Seite 662</p>	<p>Model Steel, slot 8</p> <p>Description To attach frame elements to a frame structure by means of clamp profile connectors 40; completely preassembled, for lateral insertion into the profile slot, fixation by means of a nut; the upper mounting defines the position in the structure, by shifting the lower mounting afterwards the frame can be fixed and locked; 12 mm gap between frame and structure, dimensional tolerances of +/- 3 mm can be compensated</p> <p>Material T-slot nut: Steel Shim: Steel Nut: Steel Screw: Steel Ball: Stainless steel</p> <p>Set Mounting, completely preassembled: 1 T-slot nut - slot 8 - M6, 1 shim DIN 9021 - 6.4, 1 nut DIN 934 - M6, 1 screw DIN 7984 - M6 x 30, 1 ball Ø4</p> <p>Pack Quantity 10 pieces</p> <p>Tip Compatible clamp profile connector 40 (Set) see page 662</p>
--	--

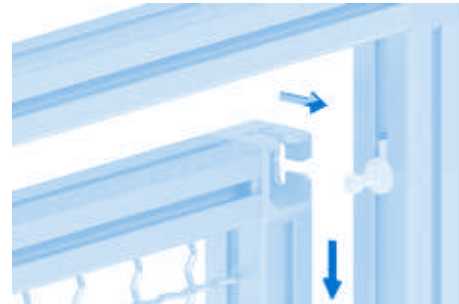
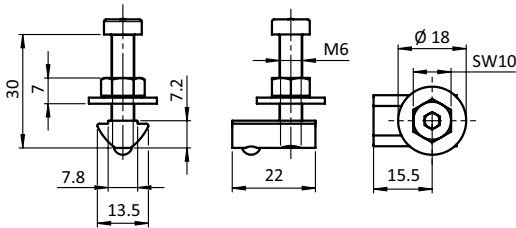

Aufhängung für Klemmprofilverbinder 40 (Set) Mounting for Clamp Profile Connector 40 (Set)	N	Gewicht [g] Weight [g]	Profil Profile	Teil-Nr. Part #
	8	16.0	I	093XWWC401N08



SET EINHÄNGEWINKEL

SET SUSPENSION BRACKET

<p>Ausführung Zinkdruckguss, Nut 10</p> <p>Beschreibung zur Befestigung eines Schutzrahmens zwischen zwei Pfosten</p> <p>Material Einhängewinkel: Zinkdruckguss, Montageset: Stahl</p> <p>Set 4 Einhängewinkel, 4 Flanschmuttern M8, 4 Hammerschrauben M8 x 20, 2 Sicherungsschrauben - Verbus Ripp B - M8 x 16, 2 Zapfen Ø 8,6 mit Rändel für Kernloch</p> <p>Liefereinheit 1 Set (= 4 Stück)</p>	<p>Model Zinc die-cast, slot 10</p> <p>Description To attach a protective frame panel between two posts</p> <p>Material Suspension Bracket: Zinc die-cast, Assembly set: Steel</p> <p>Set 4 suspension brackets, 4 flange nuts M8, 4 hammer head screws M8 x 20, 2 locking screws - Verbus Ripp B - M8 x 16, 2 knurled pins Ø 8.6, for core hole</p> <p>Pack Quantity 1 set (= 4 pieces)</p>
---	---

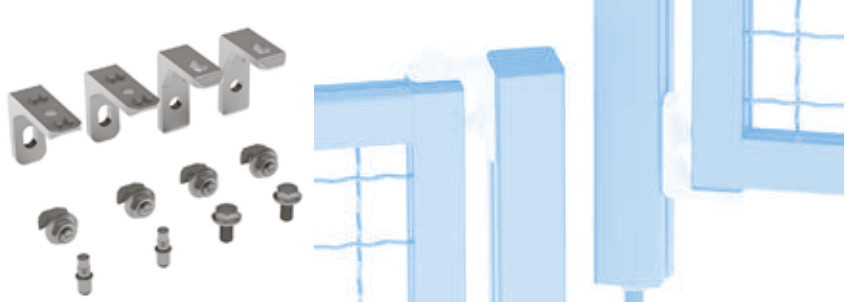
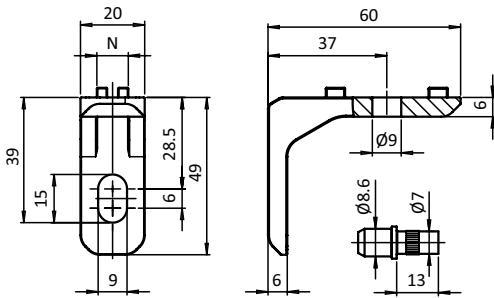

Set Einhängewinkel Set Suspension Bracket	N	Gewicht [g] Weight [g]	Profil Profile	Teil-Nr. Part #
	10	106.0	B	093WL201N10S01

SICHERHEITSAUFHÄNGUNG 8 / 8 (SET)

SAFETY HANGER 8 / 8 (SET)

<p>Ausführung Stahl, verzinkt, Nut 8</p> <p>Beschreibung zur komfortablen Aufhängung von Schutzzaunfeldern gemäß Maschinenrichtlinie 2006/42/EG; Spaltabstand 12 - 26 mm</p> <p>Material Aufhängung: Stahl Stützhaken: Stahl Stützwinkel: Stahl Senkschrauben: Edelstahl Nutensteine: Stahl</p> <p>Set 2 Aufhängungen inkl. verstemmter Sicherheitsbefestigung mit Pin, 2 Stützhaken, 2 Stützwinkel, 12 Senkschrauben DIN 7991 - M8 x 16 - mit Pin, 12 Nutensteine - Nut 8 - M8</p> <p>Liefereinheit 1 Set (= 2 x 3 Stück)</p>	<p>Model Steel, zinc plated, slot 8</p> <p>Description To comfortably hang on protective frame panels, according to Machinery Directive 2006/42/EC; gap distance 12 - 26 mm</p> <p>Material Hanger: Steel Supporting hook: Steel Supporting angle: Steel Countersunk screws: Stainless steel T-slot nuts: Steel</p> <p>Set 2 hangers incl. calked safety fastening with pin, 2 supporting hooks, 2 supporting angles, 12 countersunk screws DIN 7991 - M8 x 16 - with pin, 12 T-slot nuts - slot 8 - M8</p> <p>Pack Quantity 1 set (= 2 x 3 pieces)</p>
---	--

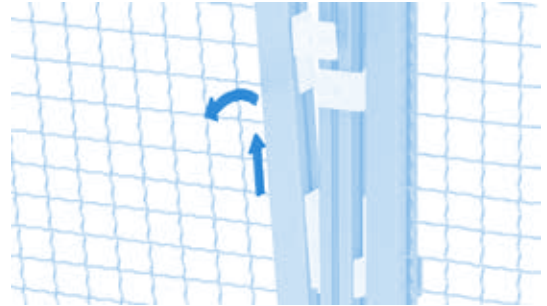
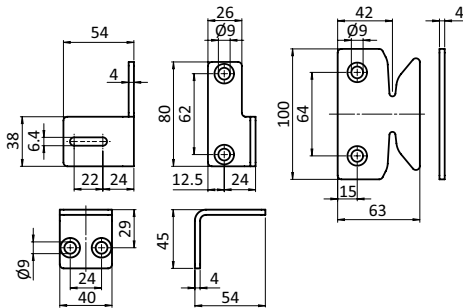

Sicherheitsaufhängung 8/8 (Set)
 Safety Hanger 8/8 (Set)

N

Gewicht [g]
 Weight [g]

Profil
 Profile

Teil-Nr.
 Part #

8 / 8

845.0

I

093WH400808



SET EINHÄNGEWINKEL CS

SET SUSPENSION BRACKET CS

<p>Ausführung Zinkdruckguss, Nut 10</p> <p>Beschreibung zur Befestigung eines Schutzrahmens zwischen zwei Pfosten, gemäß Maschinenrichtlinie 2006/42/EG</p> <p>Material Einhängewinkel: Zinkdruckguss, Montageset: Stahl, Verliersicherung: Kunststoff PA, Unverlierbarkeitsscheibe: Kunststoff PA</p> <p>Farbe Verliersicherung: schwarz, Unverlierbarkeitsscheibe: natur</p> <p>Set 2 Einhängewinkel, 2 Einhängewinkel CS vormontiert, 2 Zapfen Ø 8.6 mit Rändel für Kernloch, 2 Sicherungsschrauben - Verbus Ripp - M8 x 25, 2 Stck. Verliersicherung, 2 Unverlierbarkeitsscheiben, 4 Hammerschrauben M8 x 20, 4 Flanschmuttern M8</p> <p>Liefereinheit 1 Set (= 4 Stück)</p>	<p>Model Zinc die-cast, slot 10</p> <p>Description To attach a protective frame panel between two posts, according to Machinery Directive 2006/42/EC</p> <p>Material Suspension Bracket: Zinc die-cast Assembly set: Steel Safety strap: Plastic PA Anti-loss washer: Plastic PA</p> <p>Color Safety strap: Black, Anti-loss washer: Natural</p> <p>Set 2 suspension brackets, 2 suspension brackets, pre-assembled, 2 knurled pins Ø 8.6, for core hole, 2 locking screws - Verbus Ripp B - M8 x 25, 2 safety straps, 2 anti-loss washers, 4 hammer head screws M8 x 20, 4 flange nuts M8</p> <p>Pack Quantity 1 set (= 4 pieces)</p>
--	---

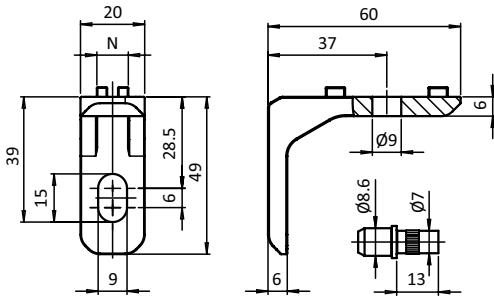

Set Einhängewinkel CS
 Set Suspension Bracket CS

N

Gewicht [g]
 Weight [g]

Profil
 Profile

Teil-Nr.
 Part #

10

207.0

B

093WL201N10S04



AUFHÄNGUNG 6-8

HANGER 6-8

Ausführung	Zinkdruckguss	Model	Zinc die-cast
Beschreibung	für die besonders steife Befestigung von Rahmenelementen an Ständerprofilen	Description	For an extra sturdy fastening of panels to fencing posts
Material	Zinkdruckguss	Material	Zinc die-cast
Liefereinheit	100 Stück	Pack Quantity	100 pieces

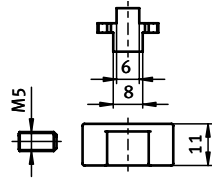
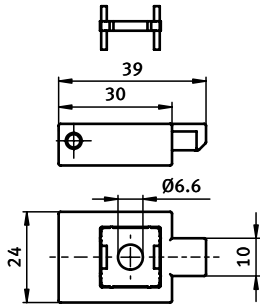

Aufhängung 6-8
Hanger 6-8

N

Gewicht [g]
Weight [g]

Teil-Nr.
Part #

6 / 8

70.0





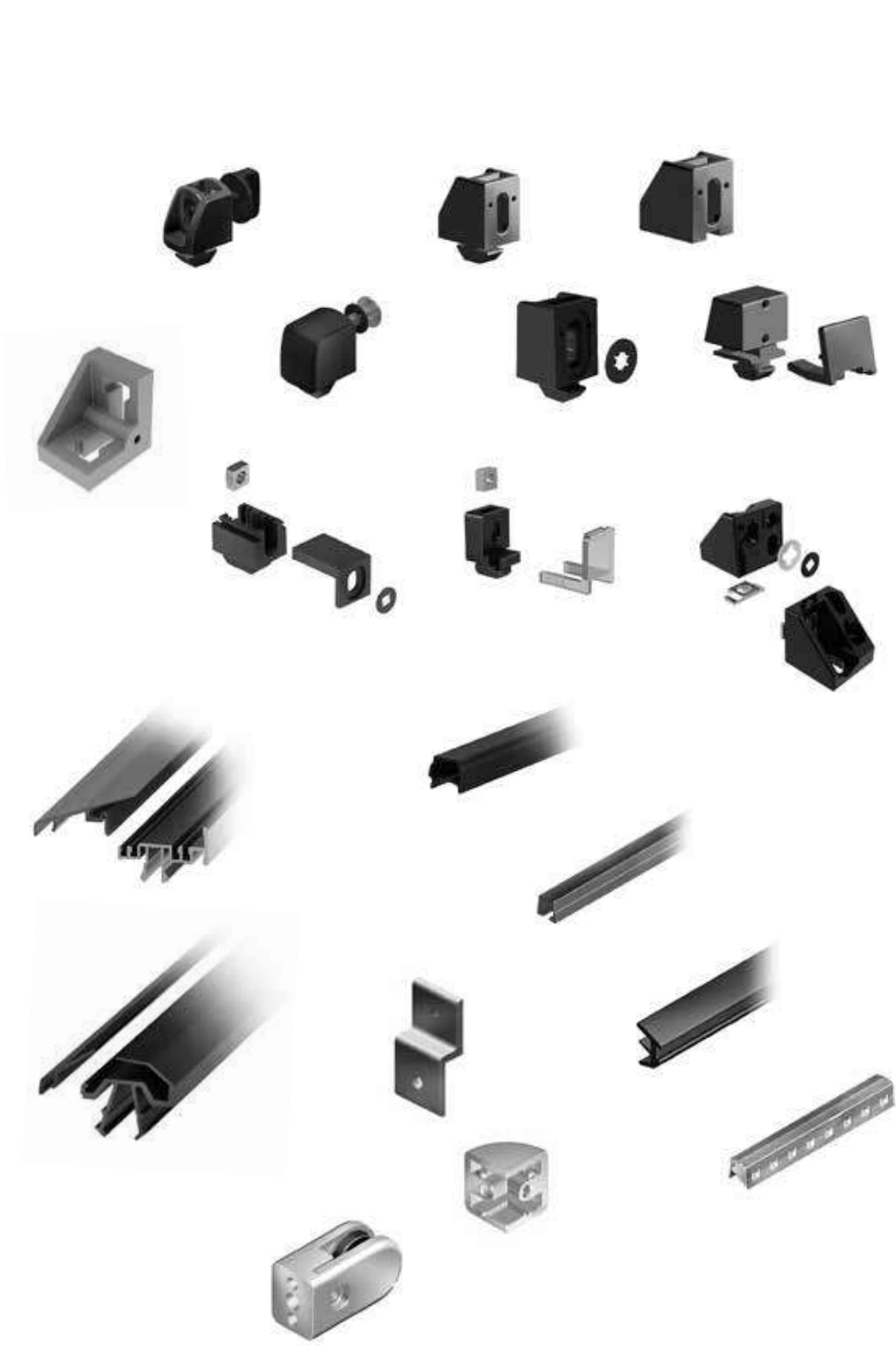

































093160

INHALTSÜBERSICHT *CONTENT OVERVIEW*









Bodenelemente <i>Floor Elements</i>	1
Scharniere <i>Hinges</i>	2
Nutmuttern und -schrauben <i>T-Nuts and T-Bolts</i>	3
Verbindungstechnik <i>Connecting Systems</i>	4
Griffe und Verschlüsse <i>Handles and Latches</i>	5
Arbeitsplatzkomponenten <i>Components for Work Stations</i>	6
Gleiter und Rollen <i>Sliders and Rollers</i>	7
Fördertechnik <i>Conveyors</i>	8
Schutz- und Trennwandelemente <i>Enclosures, Guards, Partitions</i>	9
Flächenbefestigungen <i>Panel Fasteners</i>	10
Abdeckelemente <i>Cover Elements</i>	11
Kabelführungen <i>Cable Management</i>	12
Diverse Komponenten <i>Miscellaneous Components</i>	13
Rundrohrkomponenten <i>Tubular Frame Components</i>	14



	Quick-Block 25	<i>Quick-Block 25</i>	673		Varioklemmblock 25 CS	<i>Vario Clamping Block 25 CS</i>	692
	Uniblock 14	<i>Uniblock 14</i>	674		Winkelblock 40/45	<i>Angle Block 40/45</i>	693
	Uniblock 18	<i>Uniblock 18</i>	675		Uniblock ZN 40	<i>Uniblock ZN 40</i>	694
	Uniblock 18 CS	<i>Uniblock 18 CS</i>	676		Uniblock ZN 40 CS	<i>Uniblock ZN 40 CS</i>	695
	Uniblock 25	<i>Uniblock 25</i>	677		Abdeck- und Einfassprofil	<i>Cover and Reduction Profile</i>	696
	Uniblock 25 CS	<i>Uniblock 25 CS</i>	678		Abdeck- und Einfassprofil	<i>Cover and Reduction Profile</i>	697
	Uniblock, glasklar farblos	<i>Uniblock, Transparent Colorless</i>	679		Abdeck- und Einfassprofil	<i>Cover and Reduction Profile</i>	698
	Uniblock 26 CS	<i>Uniblock 26 CS</i>	680		Abdeck- und Einfassprofil	<i>Cover and Reduction Profile</i>	699
	Uniblock 25 Clip	<i>Uniblock 25 Clip</i>	681		Abdeck- und Einfassprofil	<i>Cover and Reduction Profile</i>	700
	Uniblock 25 Langloch	<i>Uniblock 25 EH</i>	682		Einfassprofil	<i>Reduction Profile</i>	701
	Befestigungsblock 18	<i>Fixation Block 18</i>	683		Abdeck- und Einfassprofil	<i>Cover and Reduction Profile</i>	702
	Befestigungsblock 25	<i>Fixation Block 25</i>	684		Einfassprofil	<i>Reduction Profile</i>	703
	Varioblock 18 CS	<i>Vario Block 18 CS</i>	685		Einsetzprofil PVC	<i>Insert Profile PVC</i>	704
	Varioblock 25 CS	<i>Vario Block 25 CS</i>	686		Einfassprofil	<i>Holder Profile</i>	705
	Klemmblock 13	<i>Clip Block 13</i>	687		Einsetzprofil AL	<i>Insert Profile AL</i>	706
	Klemmblock 14	<i>Clip Block 14</i>	688		Scheibendichtung	<i>Plug-in Profile</i>	707
	Klemmblock 14 SL	<i>Clip Block 14 SL</i>	689		Scheibendichtung	<i>Plug-in Profile</i>	708
	Werkzeug SL	<i>Tool SL</i>	690		Scheibendichtung	<i>Plug-in Profile</i>	709
	Varioklemmblock 18	<i>Vario Clamping Block 18</i>	691		Scheibendichtung	<i>Plug-in Profile</i>	710



	Scheibendichtung	<i>Plug-in Profile</i>	711
	Klemmfederblech	<i>Clamping Spring</i>	712
	Klemmfederblech	<i>Clamping Spring</i>	713
	Glasscheibenhalter	<i>Glass Panel Clamp</i>	714
	Eckverbinder	<i>Corner Connector</i>	715
	Plattenhalter	<i>Panel Holder</i>	716



QUICK-BLOCK 25

QUICK-BLOCK 25

Ausführung	Kunststoff PA, Nut 8, 10	Model	Plastic PA, slot 8, 10
Beschreibung	zur schnellen Befestigung von Flächenelementen an Aluminiumprofilen	Description	To attach panels quickly to aluminum profiles
Material	Kunststoff PA, glasfaserverstärkt	Material	Plastic PA, glass fiber reinforced
Farbe	schwarz	Color	Black
Liefereinheit	100 Stück	Pack Quantity	100 pieces
Extras	individueller Hammer, weitere Farben auf Anfrage	Specials	Customized hammer, other colors on request

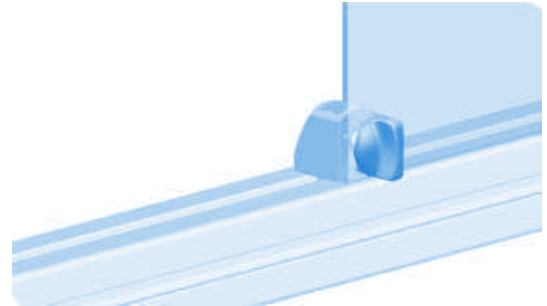
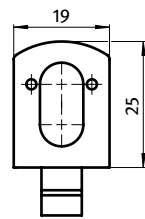
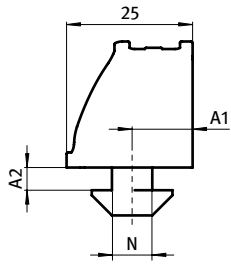

Quick-Block 25	A1 [mm]	A2 (Profil) [mm] A2 (Profile) [mm]	N	Gewicht [g] Weight [g]	Profil Profile	Teil-Nr. Part #
Lockpin M	12.0	4.4 (4.5)	8	11.0	I	094700
	8.5	5.7 (6.0)	10	12.0	B	094701
	7.0	1.9 (2.2)	8	11.0	B	094707

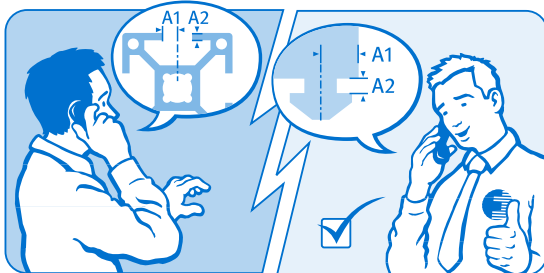
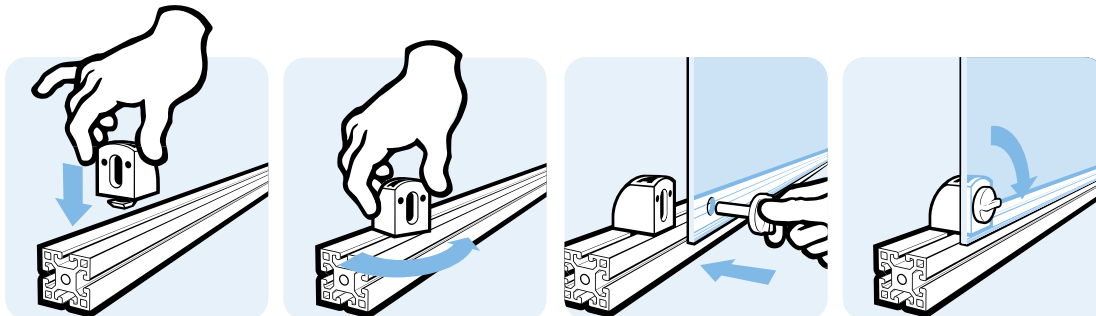



UNIBLOCK 14

UNIBLOCK 14

Ausführung	Kunststoff PA, Nut 5, 6	Model	Plastic PA, slot 5, 6
Beschreibung	zur einfachen Befestigung von Flächenelementen an Aluminiumprofilen	Description	To attach panels easily to aluminum profiles
Material	Block: Kunststoff PA, glasfaserverstärkt Mutter: Stahl, verzinkt	Material	Block: Plastic PA, glass fiber reinforced Nut: Zinc plated steel
Farbe	schwarz	Color	Black
Liefereinheit	100 Stück	Pack Quantity	100 pieces
Extras	individueller Hammer, weitere Farben auf Anfrage	Specials	Customized hammer, other colors on request
Hinweis	* keine weiteren Distanzstücke aufsteckbar!	Tip	* no further spacers can be added!

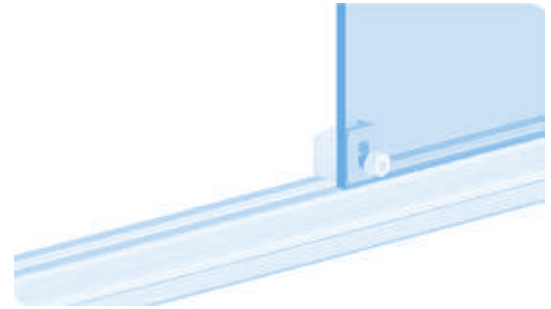
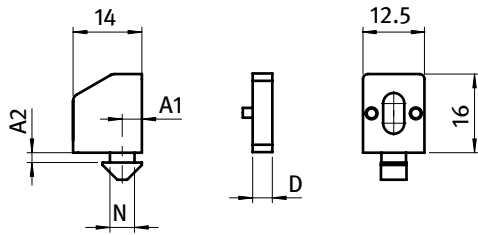

Uniblock 14	A1 [mm]	A2 [mm]	D [mm]	N	Gewinde Thread	Gewicht [g] Weight [g]	Profil Profile	Teil-Nr. Part #
	4.0	1.6		5	M4	2.6	I	094411M4
Distanzstück Spacer			*1.0			0.5		094901
			*2.0			0.8		094902
			3.0			1.3		094903
			4.0			1.8		094904

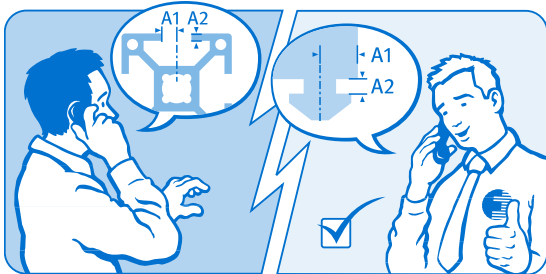
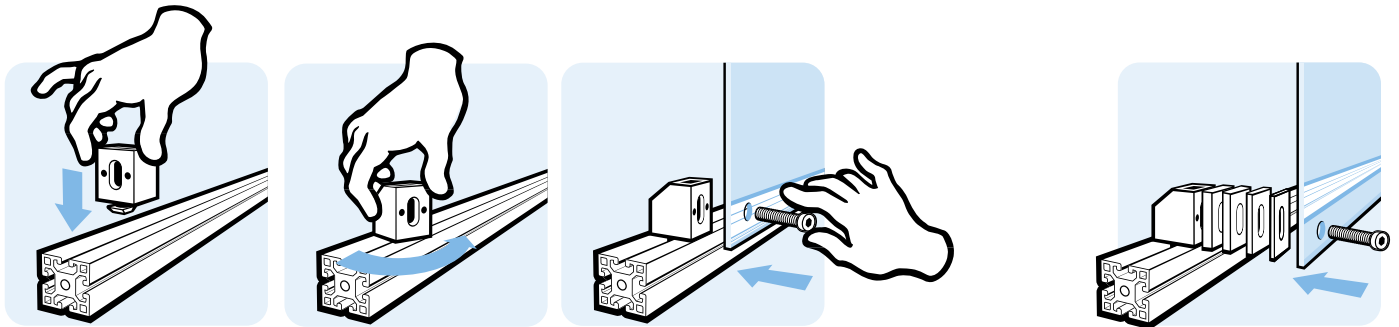

10



UNIBLOCK 18

UNIBLOCK 18

Ausführung	Kunststoff PA, Nut 6, 8, 10, 12	Model	Plastic PA, slot 6, 8, 10, 12
Beschreibung	zur einfachen Befestigung von Flächenelementen an Aluminiumprofilen	Description	To attach panels easily to aluminum profiles
Material	Block: Kunststoff PA, glasfaserverstärkt Mutter: Stahl, verzinkt	Material	Block: Plastic PA, glass fiber reinforced Nut: Zinc plated steel
Farbe	schwarz	Color	Black
Liefereinheit	100 Stück	Pack Quantity	100 pieces
Extras	individueller Hammer, weitere Farben auf Anfrage	Specials	Customized hammer, other colors on request
Hinweis	* keine weiteren Distanzstücke aufsteckbar!	Tip	* no further spacers can be added!

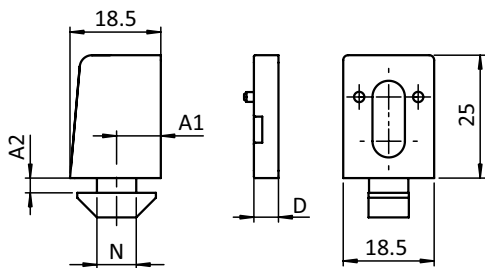

Uniblock 18	A1 [mm]	A2 (Profil) [mm] A2 (Profile) [mm]	D [mm]	N	Gewinde Thread	Gewicht [g] Weight [g]	Profil Profile	Teil-Nr. Part #
	7.0	2.7 (3.0)		6	M4	8.0	I	094100M4
	7.0	2.7 (3.0)		6	M5	8.1	I	094100M5
	7.0	2.7 (3.0)		6	M6	8.2	I	094100M6
	7.0	1.9 (2.2)		8	M4	8.3	B	094002M4
	7.0	1.9 (2.2)		8	M5	8.4	B	094002M5
	7.0	1.9 (2.2)		8	M6	8.6	B	094002M6
Distanzstück Spacer			*2.0			1.0		094102
			3.0			1.2		094103
			5.0			2.1		094105

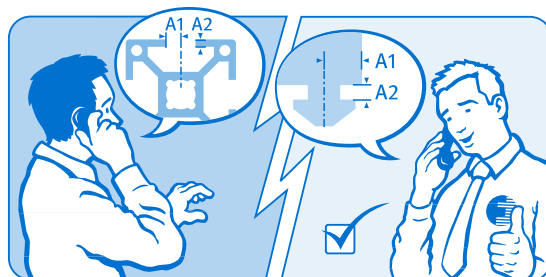



UNIBLOCK 18 CS

UNIBLOCK 18 CS

Ausführung	mit Verliersicherung für Schraube	Model	With screw retainer
Beschreibung	zur sicheren Befestigung von Flächenelementen an Aluminiumprofilen; mit Verliersicherung für Schraube gemäß Maschinenrichtlinie 2006/42/EG	Description	To attach panels safely to aluminum profiles; with screw retainer to comply with Machinery Directive 2006/42/EC
Material	Block: Kunststoff PA, glasfaserverstärkt Mutter: Stahl, verzinkt	Material	Block: Plastic PA, glass fiber reinforced Nut: Zinc plated steel
Farbe	schwarz	Color	Black
Liefereinheit	100 Stück	Pack Quantity	100 pieces
Extras	individueller Hammer, weitere Farben auf Anfrage	Specials	Customized hammer, other colors on request
Hinweis	* keine weiteren Distanzstücke aufsteckbar!	Tip	* no further spacers can be added!

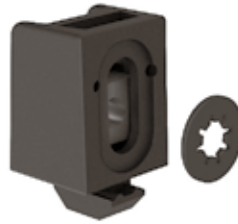
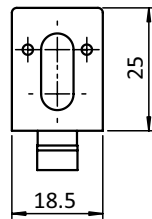
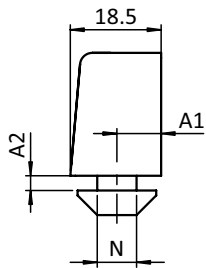

Uniblock 18 CS	A1 [mm]	A2 (Profil) [mm] A2 (Profile) [mm]	D [mm]	N	Gewinde Thread	Gewicht [g] Weight [g]	Profil Profile	Teil-Nr. Part #
	7.0	2.7 (3.0)		6	M6	9.0	I	094100CSM6
	7.0	1.9 (2.2)		8	M6	8.5	B	094002CSM6
Distanzstück CS Spacer CS			*2.0			0.8		094102CS
			3.0			1.0		094103CS
			5.0			1.9		094105CS

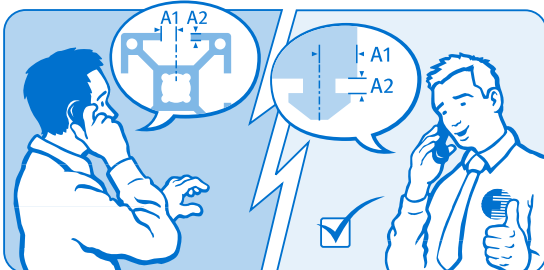
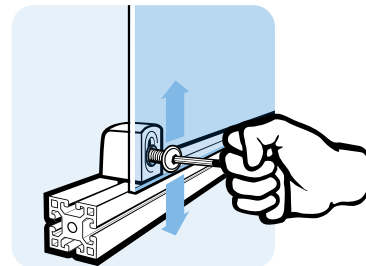
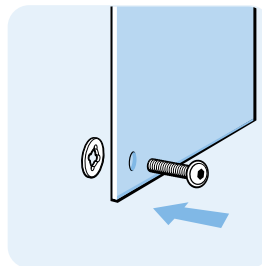
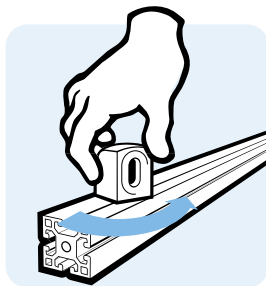
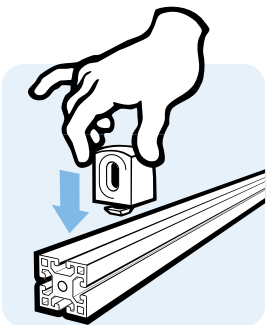

10



UNIBLOCK 25

UNIBLOCK 25

Ausführung	Kunststoff PA, Nut 8, 10, 12	Model	Plastic PA, slot 8, 10, 12
Beschreibung	zur einfachen Befestigung von Flächenelementen an Aluminiumprofilen	Description	To attach panels easily to aluminum profiles
Material	Block: Kunststoff PA, glasfaserverstärkt Mutter: Stahl, verzinkt	Material	Block: Plastic PA, glass fiber reinforced Nut: Zinc plated steel
Farbe	schwarz	Color	Black
Liefereinheit	100 Stück	Pack Quantity	100 pieces
Extras	individueller Hammer, weitere Farben auf Anfrage	Specials	Customized hammer, other colors on request
Hinweis	* keine weiteren Distanzstücke aufsteckbar!	Tip	* no further spacers can be added!

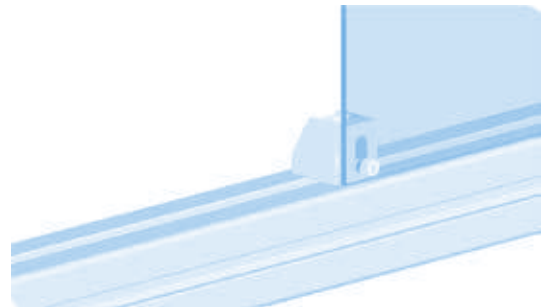
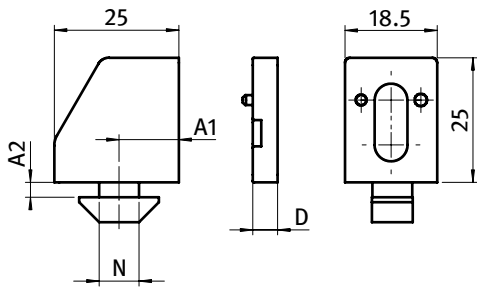

Uniblock 25	A1 [mm]	A2 (Profil) [mm] A2 (Profile) [mm]	D [mm]	N	Gewinde Thread	Gewicht [g] Weight [g]	Profil Profile	Teil-Nr. Part #
	8.0	4.35 (4.5)		8	M4	9.8	I	094003M4
	8.0	4.35 (4.5)		8	M5	9.7	I	094003M5
	8.0	4.35 (4.5)		8	M6	9.6	I	094003M6
	12.0	4.4 (4.5)		8	M4	9.8	I	094020M4
	12.0	4.4 (4.5)		8	M5	9.7	I	094020M5
	12.0	4.4 (4.5)		8	M6	9.6	I	094020M6
	14.0	4.6 (4.5)		8	M4	10.0	I	094080M4
	14.0	4.6 (4.5)		8	M5	9.9	I	094080M5
	14.0	4.6 (4.5)		8	M6	9.8	I	094080M6
	8.5	5.7 (6.0)		10	M4	10.6	B	094008M4
	8.5	5.7 (6.0)		10	M5	10.5	B	094008M5
	8.5	5.7 (6.0)		10	M6	10.4	B	094008M6
	9.5	5.6 (6.0)		10	M4	10.6	B	094004M4
	9.5	5.6 (6.0)		10	M5	10.5	B	094004M5
	9.5	5.6 (6.0)		10	M6	10.4	B	094004M6
	14.0	6.0 (6.0)		10	M4	10.4	B	094005M4
	14.0	6.0 (6.0)		10	M5	10.3	B	094005M5
	14.0	6.0 (6.0)		10	M6	10.2	B	094005M6
Distanzstück Spacer			*2.0			1.0		094102
			3.0			1.2		094103
			5.0			2.1		094105

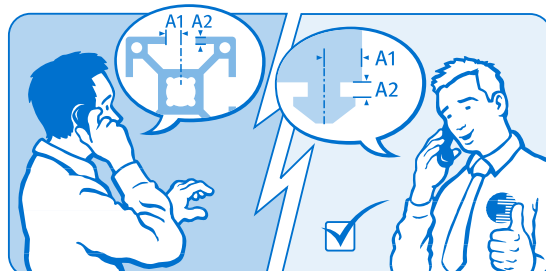



UNIBLOCK 25 CS

UNIBLOCK 25 CS

Ausführung	mit Verliersicherung für Schraube	Model	With screw retainer
Beschreibung	zur sicheren Befestigung von Flächenelementen an Aluminiumprofilen; mit Verliersicherung für Schraube gemäß Maschinenrichtlinie 2006/42/EG	Description	To attach panels safely to aluminum profiles; with screw retainer to comply with Machinery Directive 2006/42/EC
Material	Block: Kunststoff PA, glasfaserverstärkt Mutter: Stahl, verzinkt	Material	Block: Plastic PA, glass fiber reinforced Nut: Zinc plated steel
Farbe	schwarz	Color	Black
Liefereinheit	100 Stück	Pack Quantity	100 pieces
Extras	individueller Hammer, weitere Farben auf Anfrage	Specials	Customized hammer, other colors on request
Hinweis	* keine weiteren Distanzstücke aufsteckbar!	Tip	* no further spacers can be added!

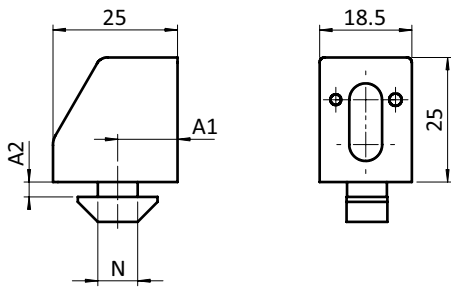

Uniblock 25 CS	A1 [mm]	A2 (Profil) [mm] A2 (Profile) [mm]	D [mm]	N	Gewinde Thread	Gewicht [g] Weight [g]	Profil Profile	Teil-Nr. Part #
	8.0	4.35 (4.5)		8	M6	10.0	I	094003CSM6
	12.0	4.4 (4.5)		8	M6	10.0	I	094020CSM6
	14.0	4.6 (4.5)		8	M6	11.0	I	094080CSM6
	9.5	5.6 (6.0)		10	M6	12.0	B	094004CSM6
	8.5	5.7 (6.0)		10	M6	11.5	B	094008CSM6
	14.0	6.0 (6.0)		10	M6	10.0	B	094005CSM6
Distanzstück Spacer			*2.0			0.8		094102CS
			3.0			1.0		094103CS
			5.0			1.9		094105CS

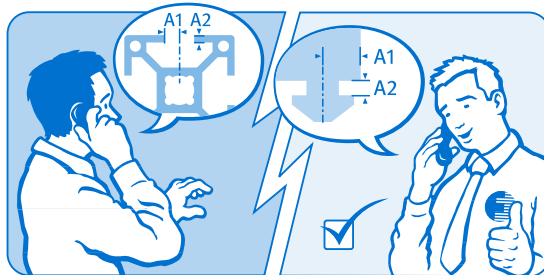

Flächenbefestigungen *Panel Fasteners*
 Flächenhalteblöcke *Panel Fixation Blocks*
 Uniblöcke *Uniblocks*



UNIBLOCK, GLASKLAR FARBLOS

UNIBLOCK, TRANSPARENT COLORLESS

Ausführung	Kunststoff PC, Nut 8, 10	Model	Plastic PC, slot 8, 10
Beschreibung	zur einfachen Befestigung von Flächenelementen an Aluminiumprofilen	Description	To attach panels easily to aluminum profiles
Material	Block: Kunststoff PC Mutter: Stahl, verzinkt	Material	Block: Plastic PC Nut: Zinc plated steel
Farbe	glasklar farblos	Color	Transparent colorless
Liefereinheit	100 Stück	Pack Quantity	100 pieces
Extras	individueller Hammer auf Anfrage	Specials	Customized hammer on request
Hinweis	* keine weiteren Distanzstücke aufsteckbar!	Tip	* no further spacers can be added!

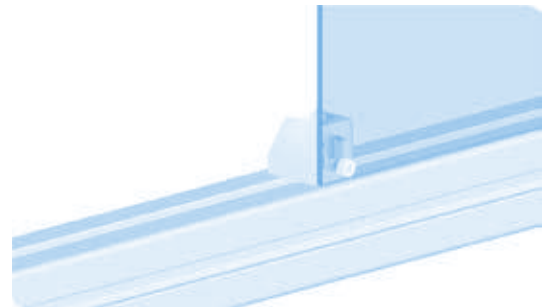
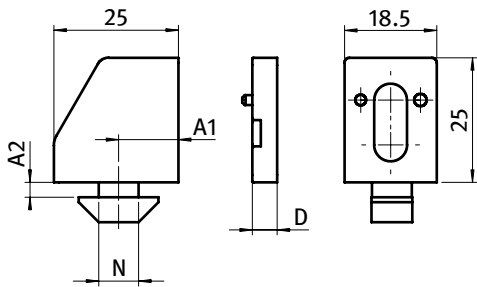

Uniblock, glasklar farblos <i>Uniblock, Transparent Colorless</i>	A1 [mm]	A2 (Profil) [mm] A2 (Profile) [mm]	D [mm]	N	Gewinde Thread	Gewicht [g] Weight [g]	Profil Profile	Teil-Nr. Part #
	8.0	4.35 (4.5)		8	M6		I	094003GM6
	12.0	4.4 (4.5)		8	M6		I	094020GM6
	14.0	6.0 (6.0)		10	M6		B	094005GM6
Distanzstück <i>Spacer</i>			*2.0			0.7		094102G
			3.0			1.2		094103G
			5.0			2.0		094105G

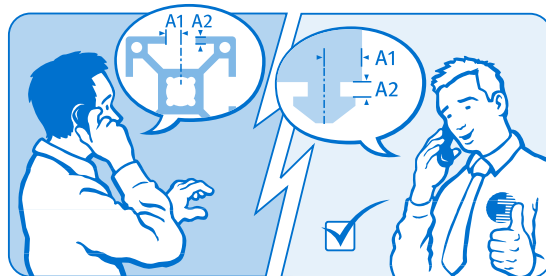

Flächenbefestigungen *Panel Fasteners*
 Flächenhalteblöcke *Panel Fixation Blocks*
 Uniblöcke *Uniblocks*



UNIBLOCK 26 CS

UNIBLOCK 26 CS

Ausführung	mit Verliersicherung für Schraube	Model	With screw retainer
Beschreibung	zur sicheren Befestigung von Flächenelementen mit 2 - 12 mm an Aluminiumprofilen; mit Verliersicherung für Schraube gemäß Maschinenrichtlinie 2006/42/EG	Description	To attach panels with a thickness of 2 - 12 mm safely to aluminum profiles; with screw retainer to comply with Machinery Directive 2006/42/EC
Material	Block: Kunststoff PA, glasfaserverstärkt Mutter: Stahl, verzinkt	Material	Block: Plastic PA, glass fiber reinforced Nut: Zinc plated steel
Farbe	schwarz	Color	Black
Liefereinheit	100 Stück	Pack Quantity	100 pieces
Extras	individueller Hammer, weitere Farben auf Anfrage	Specials	Customized hammer, other colors on request

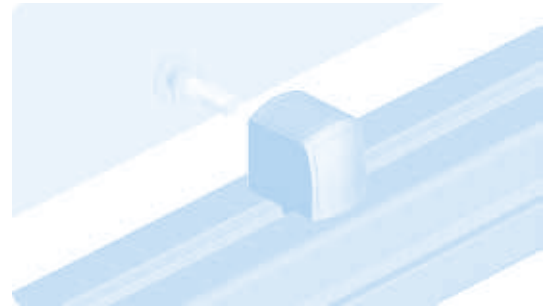
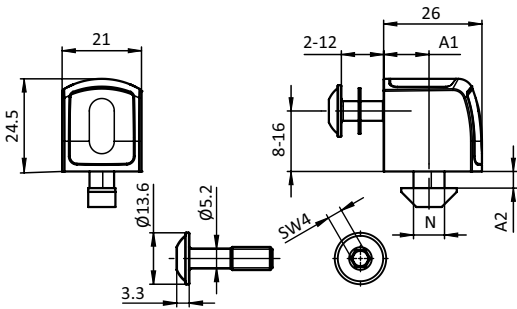

Uniblock 26 CS	A1 [mm]	A2 (Profil) [mm] A2 (Profile) [mm]	N	Gewicht [g] Weight [g]	Profil Profile	Teil-Nr. Part #
	12.0	4.4 (4.5)	8	20.0	I	094620CSS02
	14.0	6.3 (6.0)	10	21.0	B	094605CSS02

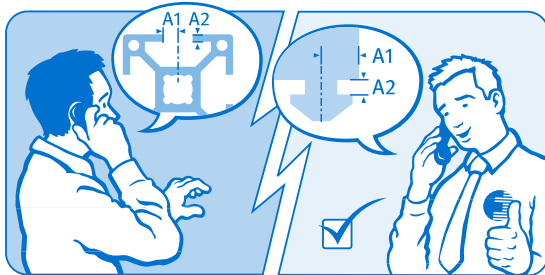
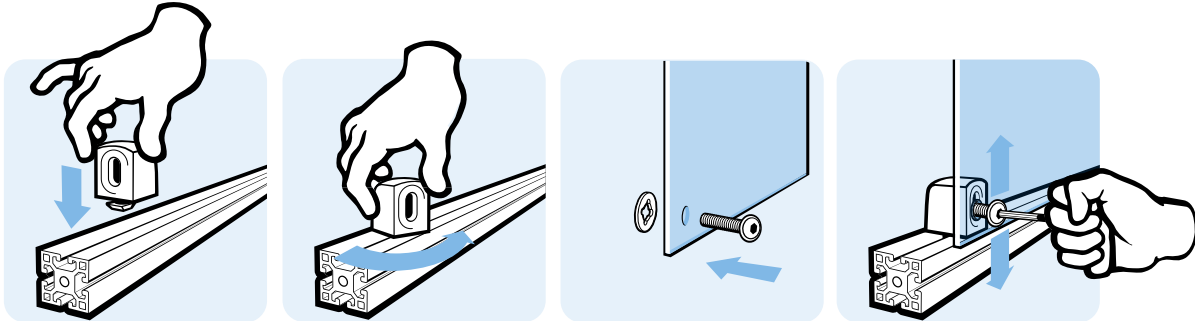

10



UNIBLOCK 25 CLIP

UNIBLOCK 25 CLIP

Ausführung	Kunststoff PA, Nut 8	Model	Plastic PA, slot 8
Beschreibung	zur einfachen Befestigung von Flächenelementen an Aluminiumprofilen; durch die Einclipsfunktion ist eine Vormontage am Flächenelement möglich	Description	To attach panels simply to aluminum profiles; the clip feature makes it possible to pre-mount the block to the panel
Material	Block: Kunststoff PA, glasfaserverstärkt Mutter: Stahl, verzinkt	Material	Block: Plastic PA, glass fiber reinforced Nut: Zinc plated steel
Farbe	schwarz	Color	Black
Liefereinheit	100 Stück	Pack Quantity	100 pieces
Extras	individuelle Clips, weitere Farben auf Anfrage	Specials	Customized clips, other colors on request
Hinweis	* keine weiteren Distanzstücke aufsteckbar!	Tip	* no further spacers can be added!

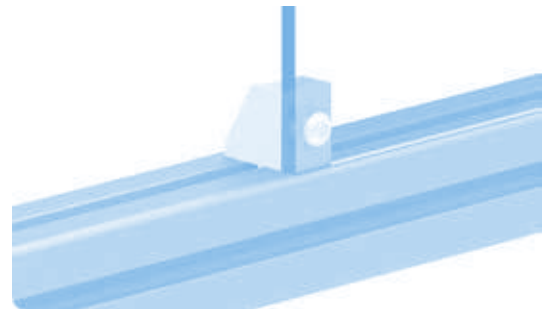
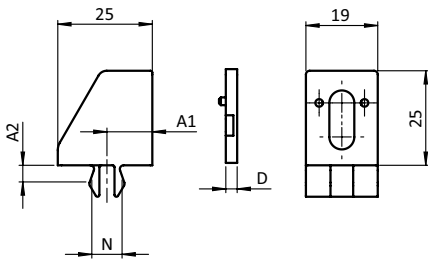

Uniblock 25 Clip	A1 [mm]	A2 (Profil) [mm] A2 (Profile) [mm]	D [mm]	N	Gewinde Thread	Gewicht [g] Weight [g]	Profil Profile	Teil-Nr. Part #
	12.0	4.4 (4.5)	-	8	M6	9.0	I	094020CLIPM6
Distanzstück Spacer			*2.0			1.0		094102
			3.0			1.2		094103
			5.0			2.1		094105

UNIBLOCK 25 LANGLOCH

UNIBLOCK 25 EH

Ausführung	Kunststoff PA	Model	Plastic PA
Beschreibung	zur variablen Befestigung von Flächenelementen an Aluminiumprofilen	Description	To attach panels variably to aluminum profiles
Material	Block: Kunststoff PA, glasfaserverstärkt Mutter: Stahl, verzinkt	Material	Block: Plastic PA, glass fiber reinforced Nut: Zinc plated steel
Farbe	schwarz	Color	Black
Liefereinheit	100 Stück	Pack Quantity	100 pieces
Extras	☁ elektrostatisch entladend, weitere Größen, weitere Farben auf Anfrage	Specials	☁ electrostatically discharging, other sizes, other colors on request
Hinweis	* keine weiteren Distanzstücke aufsteckbar!	Tip	* no further spacers can be added!

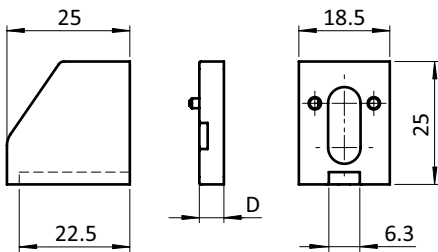

Uniblock 25 Langloch Uniblock 25 EH	Gewinde Thread	D [mm]	Gewicht [g] Weight [g]	Teil-Nr. Part #
	M4		10.0	094010M4
	M5		10.0	094010M5
	M6		10.0	094010M6
Distanzstück Spacer		*2.0	1.0	094102
		3.0	1.2	094103
		5.0	2.1	094105

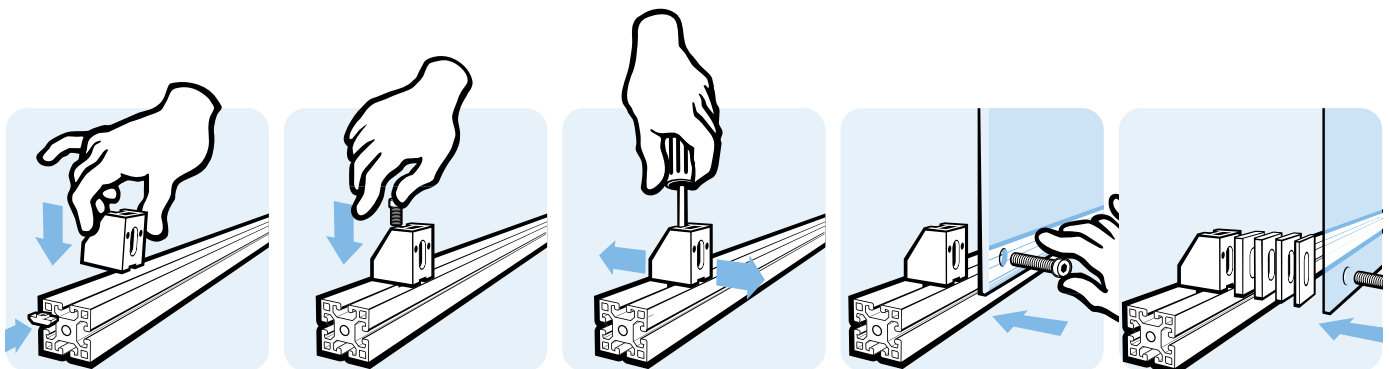

10

Flächenbefestigungen *Panel Fasteners*
 Flächenhalteblöcke *Panel Fixation Blocks*
 Befestigungsblöcke *Fixation Blocks*



BEFESTIGUNGSBLOCK 18

FIXATION BLOCK 18

Ausführung	Kunststoff PA	Model	Plastic PA
Beschreibung	zur einfachen Befestigung von Flächenelementen an Aluminiumprofilen	Description	To attach panels easily to aluminum profiles
Material	Block: Kunststoff PA, glasfaserverstärkt Mutter: Stahl, verzinkt	Material	Block: Plastic PA, glass fiber reinforced Nut: Zinc plated steel
Farbe	schwarz	Color	Black
Liefereinheit	100 Stück	Pack Quantity	100 pieces
Extras	individueller Hammer, weitere Farben auf Anfrage	Specials	Customized hammer, other colors on request
Hinweis	* A1-Maß mit Distanzstück!	Tip	* A1 size with spacer!



Befestigungsblock 18 Fixation Block 18	A1 [mm]	A2 (Profil) [mm] A2 (Profile) [mm]	N	Gewinde Thread	Gewicht [g] Weight [g]	Profil Profile	Teil-Nr. Part #
	6.0 / 9.0* / 12.0 / 15.0*	2.4 (3.0)	6	M5	5.0	I	094501M5

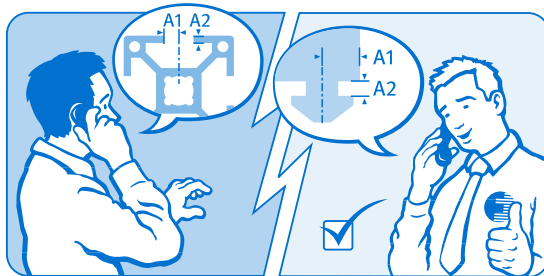



BEFESTIGUNGSBLOCK 25

FIXATION BLOCK 25

Ausführung	Kunststoff PA	Model	Plastic PA
Beschreibung	zur einfachen Befestigung von Flächenelementen an Aluminiumprofilen	Description	To attach panels easily to aluminum profiles
Material	Block: Kunststoff PA, glasfaserverstärkt Mutter: Stahl, verzinkt	Material	Block: Plastic PA, glass fiber reinforced Nut: Zinc plated steel
Farbe	schwarz	Color	Black
Liefereinheit	100 Stück	Pack Quantity	100 pieces
Extras	individueller Hammer, weitere Farben auf Anfrage	Specials	Customized hammer, other colors on request
Hinweis	* A1-Maß mit Distanzstück!	Tip	* A1 size with spacer!

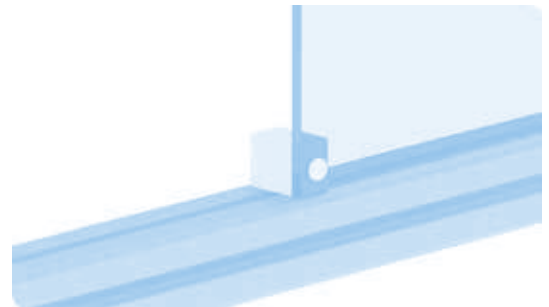
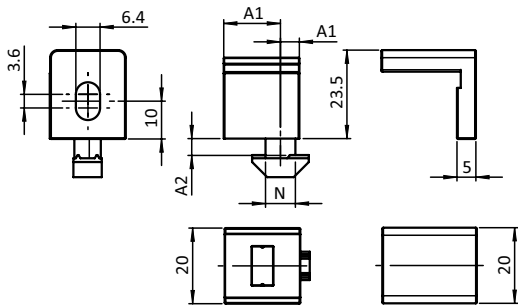

Befestigungsblock 25 Fixation Block 25	A1 [mm]	A2 (Profil) [mm] A2 (Profile) [mm]	N	Gewinde Thread	Gewicht [g] Weight [g]	Profil Profile	Teil-Nr. Part #
	5.0 / 10.0* / 15.0 / 20.0*	4.35 (4.5)	8	M6	13.0	I	094500M6

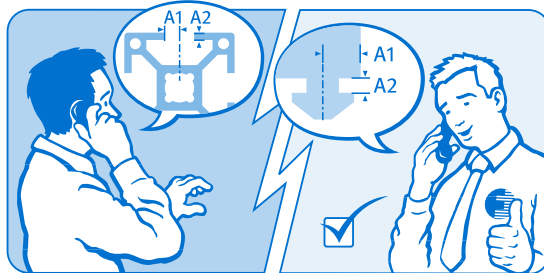

Flächenbefestigungen *Panel Fasteners*
 Flächenhalteblöcke *Panel Fixation Blocks*
 Varioblöcke *Vario Blocks*



VARIOBLOCK 18 CS

VARIO BLOCK 18 CS

Ausführung	Kunststoff PA, Nut 8	Model	Plastic PA, slot 8
Beschreibung	zur einfachen Befestigung von Flächenelementen an Aluminiumprofilen; mit Verliersicherung für Schraube gemäß Maschinenrichtlinie 2006/42/EG	Description	To attach panels simply to aluminum profiles; with screw retainer to comply with Machinery Directive 2006/42/EC
Material	Block: Kunststoff PA, glasfaserverstärkt Mutter: Stahl	Material	Block: Plastic PA, glass fiber reinforced Nut: Steel
Farbe	Block: schwarz	Color	Block: Black
Liefereinheit	100 Stück	Pack Quantity	100 pieces
Extras	weitere Farben auf Anfrage	Specials	Other colors on request
Hinweis	* A1-Maß mit Distanzstück!	Tip	* A1 size with spacer!

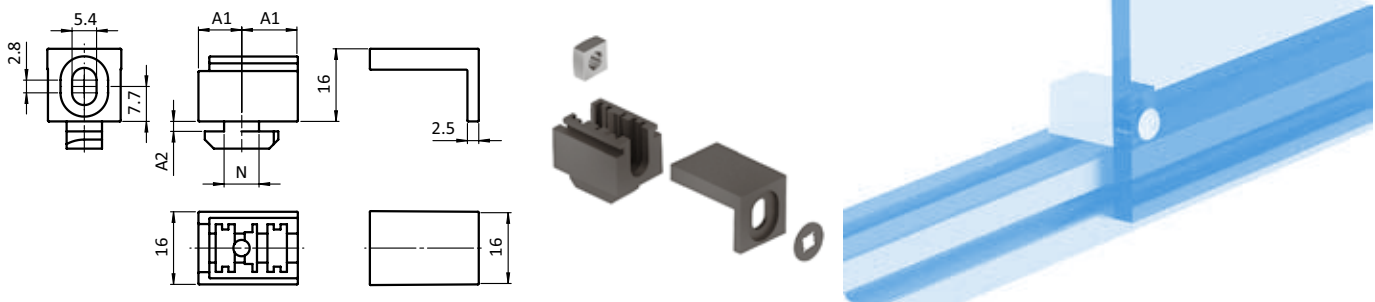

Varioblock 18 CS Vario Block 18 CS	A1 [mm]	A2 (Profil) [mm] A2 (Profile) [mm]	N	Gewinde Thread	Gewicht [g] Weight [g]	Profil Profile	Teil-Nr. Part #
	9.5 / 12* / 12.5 / 15*	2.2 (2.2)	8	M5	8.8	B	094511M5CS

Flächenbefestigungen *Panel Fasteners*
 Flächenhalteblöcke *Panel Fixation Blocks*
 Varioblöcke *Vario Blocks*



VARIOBLOCK 25 CS

VARIO BLOCK 25 CS

Ausführung	Kunststoff PA, Nut 10	Model	Plastic PA, slot 10
Beschreibung	zur einfachen Befestigung von Flächenelementen an Aluminiumprofilen; mit Verliersicherung für Schraube gemäß Maschinenrichtlinie 2006/42/EG	Description	To attach panels simply to aluminum profiles; with screw retainer to comply with Machinery Directive 2006/42/EC
Material	Block: Kunststoff PA, glasfaserverstärkt Mutter: Stahl	Material	Block: Plastic PA, glass fiber reinforced Nut: Steel
Farbe	Block: schwarz	Color	Block: Black
Liefereinheit	100 Stück	Pack Quantity	100 pieces
Extras	weitere Farben auf Anfrage	Specials	Other colors on request
Hinweis	* A1-Maß mit Distanzstück!	Tip	* A1 size with spacer!

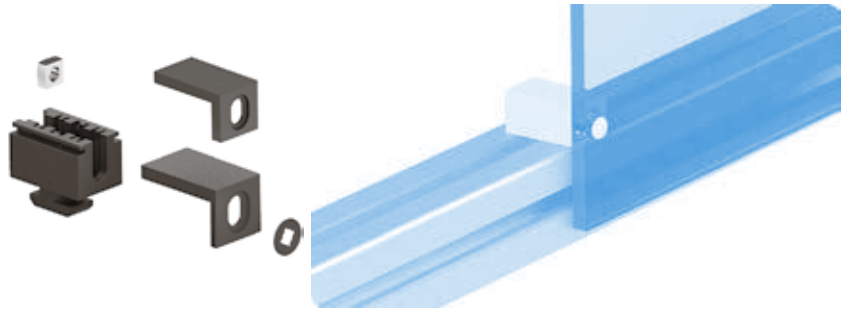
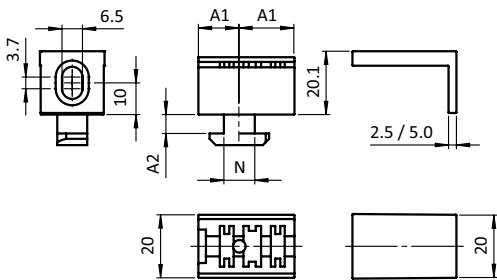

Varioblock 25 CS
 Vario Block 25 CS

A1 [mm]	A2 (Profil) [mm] A2 (Profile) [mm]	N	Gewinde Thread	Gewicht [g] Weight [g]	Profil Profile	Teil-Nr. Part #
2.5: 13 / 15.5* / 17.5 / 20* 5.0: 13 / 18* / 17.5 / 22.5*	6.0 (6.0)	10	M5	18.8	B	094513M5CS



KLEMMBLOCK 13

CLIP BLOCK 13

Ausführung Kunststoff PA, Nut 5, 6
Beschreibung zur werkzeuglosen Befestigung von Flächenelementen an Aluminiumprofilen
Material Kunststoff PA, glasfaserverstärkt
Farbe schwarz
Spannbreite Flächenelemente von 1 - 6 mm
Liefereinheit 100 Stück
Extras individueller Hammer, weitere Farben auf Anfrage
Hinweis * keine weiteren Distanzstücke aufsteckbar!

Model Plastic PA, slot 5, 6
Description To attach panels to aluminum profiles without screws or tools
Material Plastic PA, glass fiber reinforced
Color Black
Fixation Span Panel units with a thickness of 1 - 6 mm
Pack Quantity 100 pieces
Specials Customized hammer, other colors on request
Tip * no further spacers can be added!

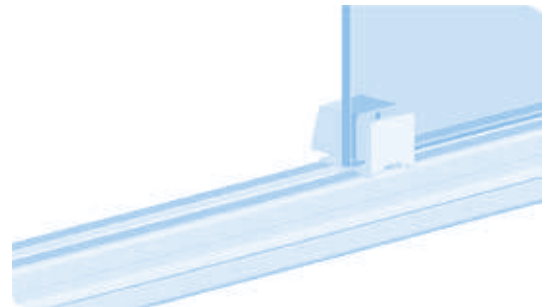
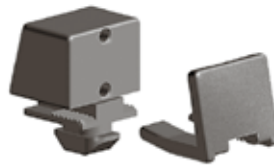
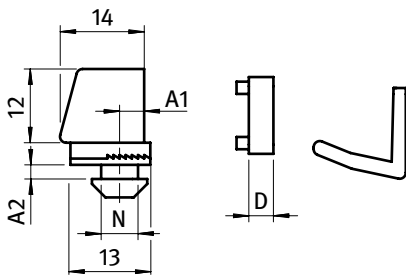

Klemmblock Clip Block	A1 [mm]	A2 (Profil) [mm] A2 (Profile) [mm]	D [mm]	N	Gewicht [g] Weight [g]	Profil Profile	Teil-Nr. Part #
	4.0	1.6 (1.8)		5	3.4	I	094311
Distanzstück Spacer			*1.0		0.5		094901
			*2.0		0.8		094902
			3.0		1.3		094903
			4.0		1.8		094904

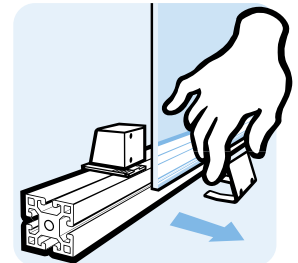
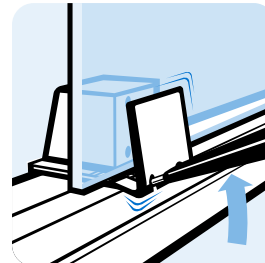
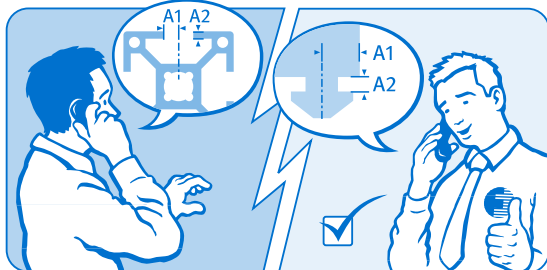
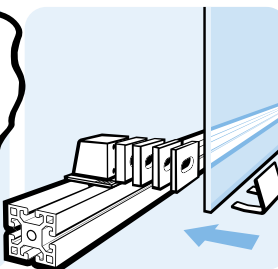
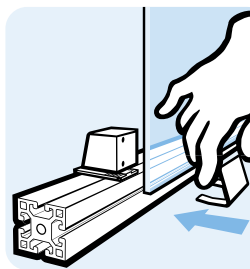
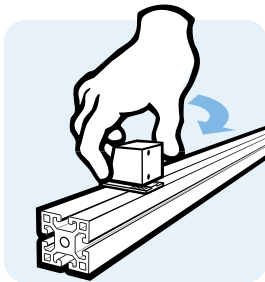
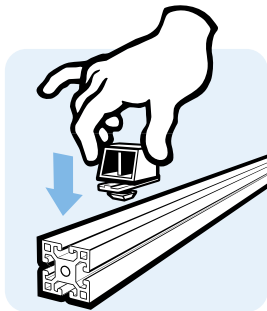

Flächenbefestigungen *Panel Fasteners*
 Flächenhalteblöcke *Panel Fixation Blocks*
 Klemmblocke *Clip Blocks*



KLEMMBLOCK 14

CLIP BLOCK 14

Ausführung	Kunststoff PA, Nut 8, 10, 12	Model	Plastic PA, slot 8, 10, 12
Beschreibung	zur werkzeuglosen Befestigung von Flächenelementen an Aluminiumprofilen	Description	To attach panels to aluminum profiles without screws or tools
Material	Kunststoff PA, glasfaserverstärkt	Material	Plastic PA, glass fiber reinforced
Farbe	schwarz	Color	Black
Spannbreite	Flächenelemente von 1 - 9 mm	Fixation Span	Panel units with a thickness of 1 - 9 mm
Liefereinheit	100 Stück	Pack Quantity	100 pieces
Extras	individueller Hammer, weitere Farben auf Anfrage	Specials	Customized hammer, other colors on request
Hinweis	* keine weiteren Distanzstücke aufsteckbar!	Tip	* no further spacers can be added!

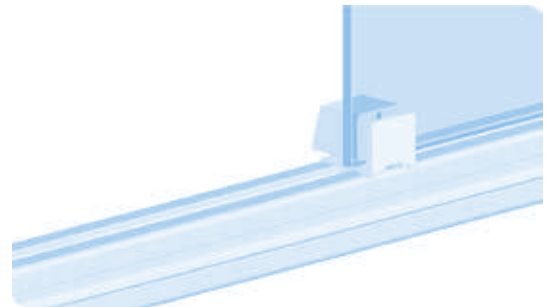
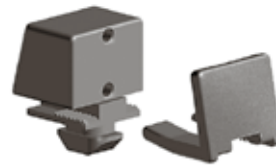
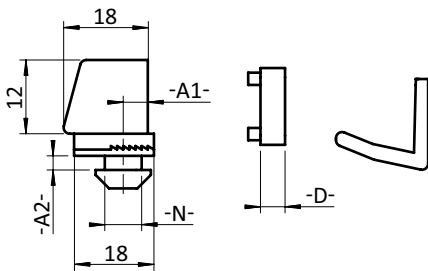

Klemmblock Clip Block	A1 [mm]	A2 (Profil) [mm] A2 (Profile) [mm]	D [mm]	N	Gewicht [g] Weight [g]	Profil Profile	Teil-Nr. Part #
	5.0	4.5 (4.5)		8	7.8	I	094204
	11.5	4.5 (4.5)		8	8.3	I	094203
	7.0	2.2 (2.2)		8	7.4	B	094202
	14.0	5.8 (6.0)		10	8.0	B	094205
Distanzstück Spacer			*2.0		1.0		094102K
			3.0		1.5		094103K
			5.0		2.0		094105K

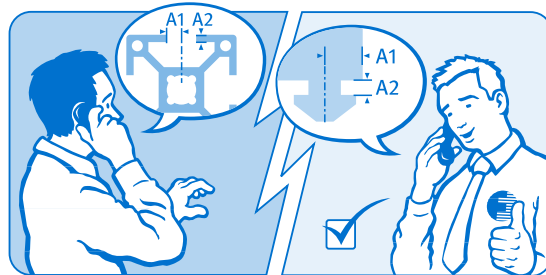

Flächenbefestigungen *Panel Fasteners*
 Flächenhalteblöcke *Panel Fixation Blocks*
 Klemmblöcke *Clip Blocks*



KLEMMBLOCK 14 SL

CLIP BLOCK 14 SL

Ausführung Kunststoff PA, Nut 8, 10, 12
Beschreibung zur schraubenlosen Befestigung von Flächenelementen an Aluminiumprofilen, zu öffnen nur mit dem Spezialwerkzeug SL
Material Kunststoff PA, glasfaserverstärkt
Farbe schwarz
Spannbreite Flächenelemente von 1 - 9 mm
Liefereinheit 100 Stück
Extras individueller Hammer, weitere Farben auf Anfrage
Hinweis Werkzeug SL für Klemmblock 14 SL siehe Seite 690

Model Plastic PA, slot 8, 10, 12
Description To attach panels easily to aluminum profiles without screws or tools; can only be opened with the special tool SL
Material Plastic PA, glass fiber reinforced
Color Black
Fixation Span Panel units with a thickness of 1 - 9 mm
Pack Quantity 100 pieces
Specials Customized hammer, other colors on request
Tip Tool SL for Clip Block 14 SL see page 690

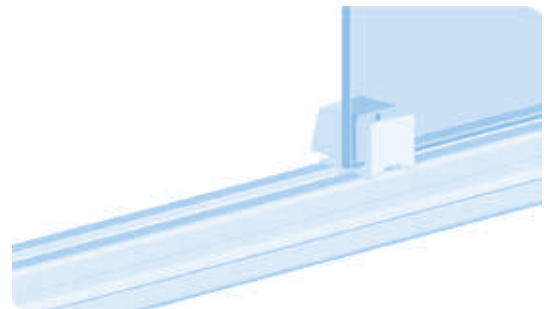
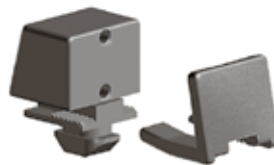
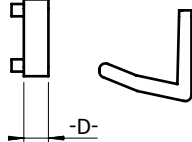
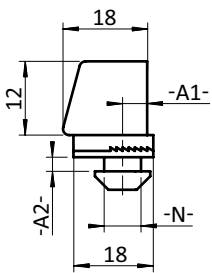

Klemmblock 14 SL Clip Block 14 SL	A1 [mm]	A2 (Profil) [mm] A2 (Profile) [mm]	D [mm]	Gewicht [g] Weight [g]	Profil Profile	Teil-Nr. Part #
	5.0	4.5 (4.5)		7.8	I	094204SL
	11.5	4.5 (4.5)		8.0	I	094203SL
	7.0	2.2 (2.2)		7.0	B	094202SL
	14.0	5.8 (6.0)		8.0	B	094205SL
Distanzstück Spacer			*2.0	1.0		094102K
			3.0	1.5		094103K
			5.0	2.0		094105K

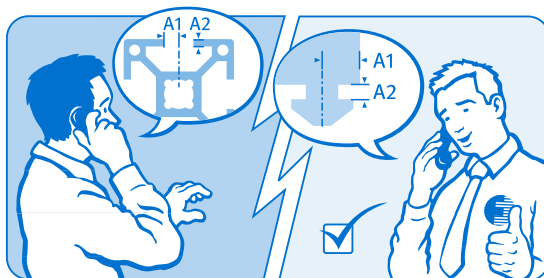

Flächenbefestigungen *Panel Fasteners*
 Flächenhalteblöcke *Panel Fixation Blocks*
 Klemmblocke *Clip Blocks*



WERKZEUG SL

TOOL SL

Ausführung	Kunststoff PA	Model	Plastic PA
Beschreibung	zum Öffnen des Klemmblocks SL	Description	To open the clip block SL
Material	Kunststoff PA, glaskugerverstärkt Stifte: Stahl, verzinkt	Material	Plastic PA, glass ball reinforced Pins: Zinc plated steel
Farbe	rot	Color	Red
Liefereinheit	1 Stück	Pack Quantity	1 piece

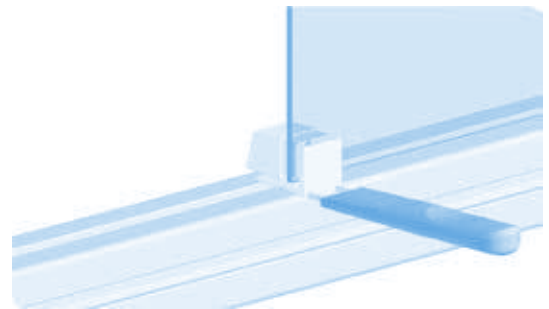
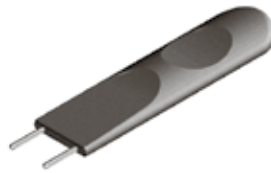
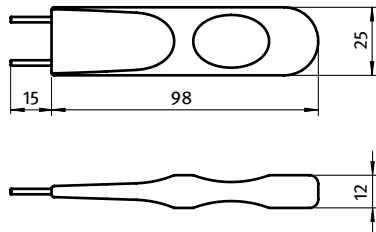

Werkzeug SL
Tool SL

Gewicht [g]
Weight [g]

Teil-Nr.
Part #

23.0

0942SL

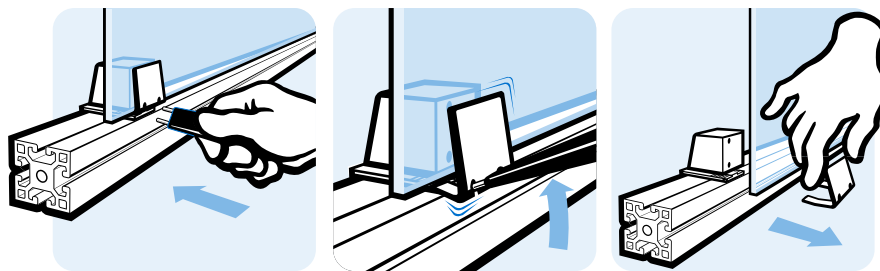

Flächenbefestigungen *Panel Fasteners*
 Flächenhalteblöcke *Panel Fixation Blocks*
 Varioklemmblocke *Vario Clamping Blocks*



VARIOKLEMMBLOCK 18

VARIO CLAMPING BLOCK 18

Ausführung	Kunststoff PA, Nut 8	Model	Plastic PA, slot 8
Beschreibung	an Aluminiumprofilen; optional schraubenlose Befestigung mit Rastklemme	Description	To attach panels safely to aluminum profiles; optional screwless mounting with clip clamp
Material	Block: Kunststoff PA, glasfaserverstärkt Rastklemme: Kunststoff PC Mutter: Stahl	Material	Block: Plastic PA, glass fiber reinforced Clip clamp: Plastic PC Nut: Steel
Farbe	Block: schwarz Rastklemme: glasklar farblos	Color	Block: Black Clip clamp: Transparent colorless
Spannbreite	mit Rastklemme von 0 - 13 mm	Fixation Span	With clip clamp from 0 to 13 mm
Liefereinheit	100 Stück	Pack Quantity	100 pieces
Extras	weitere Farben auf Anfrage	Specials	Other colors on request



Varioklemmblock 18 Vario Clamping Block 18	A1 [mm]	A2 (Profil) [mm] A2 (Profile) [mm]	N	Gewinde Thread	Gewicht [g] Weight [g]	Profil Profile	Teil-Nr. Part #
	2.5 / 8.5	2.2 (2.2)	8	M6	7.8	B	094523M6
Rastklemme <i>Clip clamp</i>					2.8		09452RA20

Flächenbefestigungen *Panel Fasteners*
 Flächenhalteblöcke *Panel Fixation Blocks*
 Varioklemmblocke *Vario Clamping Blocks*



VARIOKLEMMBLOCK 25 CS

VARIO CLAMPING BLOCK 25 CS

Ausführung	Kunststoff PA, Nut 10	Model	Plastic PA, slot 10
Beschreibung	zur sicheren Befestigung von Flächenelementen an Aluminiumprofilen; mit Verliersicherung für Schraube gemäß Maschinenrichtlinie 2006/42/EG; optional schraubenlose Befestigung mit Rastklemme	Description	To attach panels safely to aluminum profiles; with screw retainer to comply with Machinery Directive 2006/42/EC; optional screwless mounting with clip clamp
Material	Block: Kunststoff PA, glasfaserverstärkt Rastklemme: Kunststoff PC Mutter: Stahl	Material	Block: Plastic PA, glass fiber reinforced Clip clamp: Plastic PC Nut: Steel
Farbe	Block: schwarz Rastklemme: glasklar farblos	Color	Block: Black Clip clamp: Transparent colorless
Spannbreite	mit Rastklemme von 0 - 13 mm	Fixation Span	With clip clamp from 0 to 13 mm
Liefereinheit	100 Stück	Pack Quantity	100 pieces
Extras	weitere Farben auf Anfrage	Specials	Other colors on request



Varioklemmblock 25 CS Vario Clamping Block 25 CS	A1 [mm]	A2 (Profil) [mm] A2 (Profile) [mm]	N	Gewinde Thread	Gewicht [g] Weight [g]	Profil Profile	Teil-Nr. Part #
	8.5	5.8 (6.0)	10	M6	8.8	B	094522M6CS
Rastklemme <i>Clip clamp</i>					2.8		09452RA20

STAHLWINKEL 45/60

STEEL CONNECTION ANGLE 45/60

Ausführung Stahl, ab Profil 45	Model Steel, profile 45 and up
Beschreibung zur rechtwinkligen Verbindung von zwei Aluminiumprofilen	Description To connect two aluminum profiles at right angles
Material Stahl	Material Steel
Liefereinheit 10 Stück	Pack Quantity 10 pieces

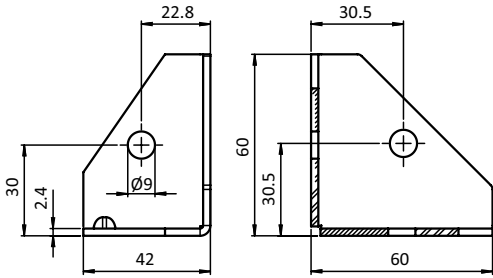

Stahlwinkel 45/60
 Steel Connection Angle 45/60

Gewicht [g]
 Weight [g]

Teil-Nr.
 Part #

elektrostatisch entladend  electrostatically discharging	112.0	093WV452V
---	-------	------------------

Flächenbefestigungen *Panel Fasteners*
 Flächenhalteblöcke *Panel Fixation Blocks*
 Uniblöcke ZN *Uni Blocks ZN*



UNIBLOCK ZN 40

UNIBLOCK ZN 40

<p>Ausführung Zinkdruckguss, Nut 8, 10</p> <p>Beschreibung Befestigung von Flächenelementen an Aluminiumprofilen, besonders für hohe Belastungen von bis zu 2.000 N auf der Fläche</p> <p>Material Zinkdruckguss</p> <p>Liefereinheit 10 Stück</p>	<p>Model Zinc die-cast, slot 8, 10</p> <p>Description To attach panels to aluminum profiles; especially for high load bearing (up to 2000 N) on the panels</p> <p>Material Zinc die-cast</p> <p>Pack Quantity 10 pieces</p>
--	---

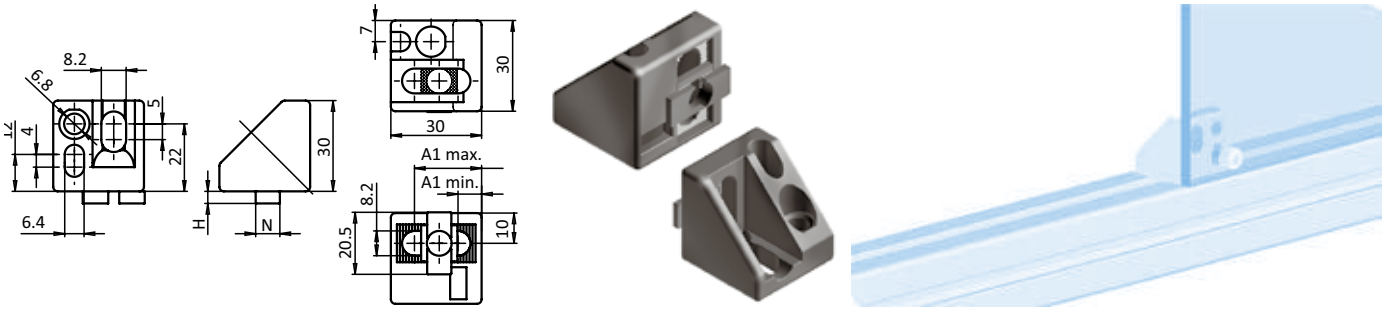

Uniblock ZN 40	A1 max. [mm]	A1 min. [mm]	H [mm]	N	Gewinde Thread	Gewicht [g] Weight [g]	Profil Profile	Teil-Nr. Part #
	22.0	8.0			M6	61.4		094Z40S
	22.0	8.0	1.7	8	M6	69.8	B	094Z40S0817
	22.0	8.0	4.0	8	M6	67.0	I	094Z40S0840
	22.0	8.0	4.0	10	M6	72.0	B	094Z40S1040

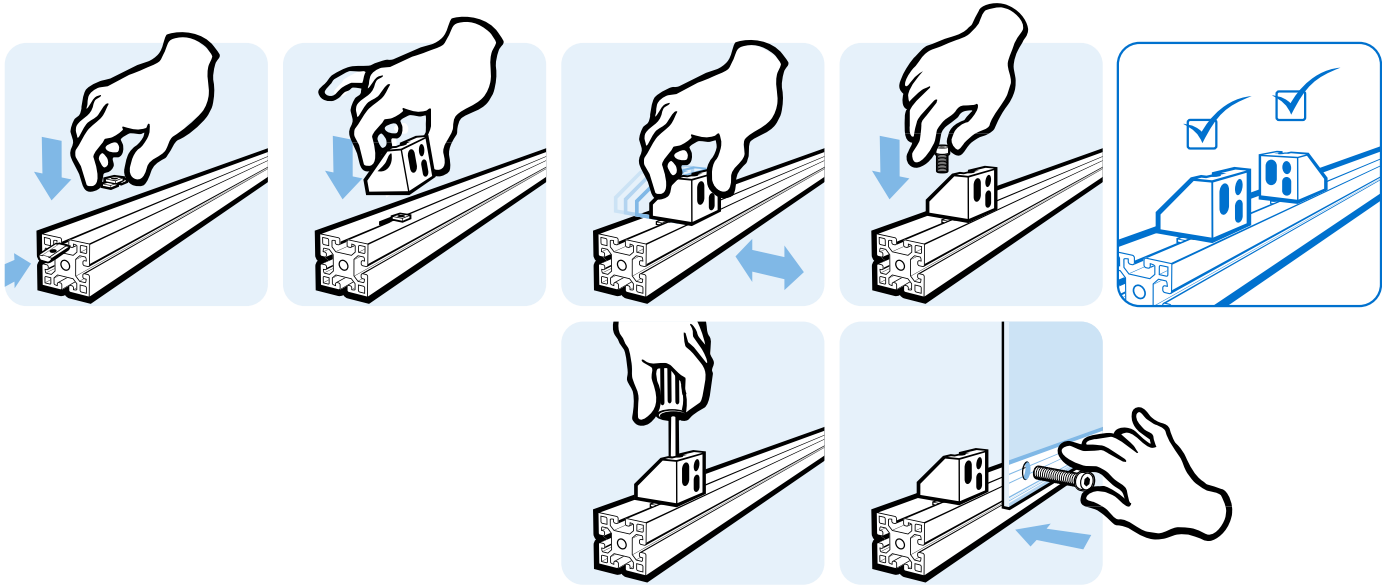

10

Flächenbefestigungen *Panel Fasteners*
 Flächenhalteblöcke *Panel Fixation Blocks*
 Uniblöcke ZN *Uni Blocks ZN*



UNIBLOCK ZN 40 CS

UNIBLOCK ZN 40 CS

Ausführung	Zinkdruckguss, Nut 8, 10	Model	Zinc die-cast, slot 8, 10
Beschreibung	Befestigung von Flächenelementen an Aluminiumprofilen, besonders für hohe Belastungen von bis zu 2.000 N auf der Fläche; mit Verliersicherung für Schraube gemäß Maschinenrichtlinie 2006/42/EG	Description	To attach panels to aluminum profiles; especially for high load bearing (up to 2000 N) on the panels; with screw retainer to comply with Machinery Directive 2006/42/EC
Material	Zinkdruckguss	Material	Die-cast zinc
Oberfläche	schwarz verzinkt (RoHS-konform)	Surface	Black zinc plated (RoHS compliant)
Liefereinheit	10 Stück	Pack Quantity	10 pieces

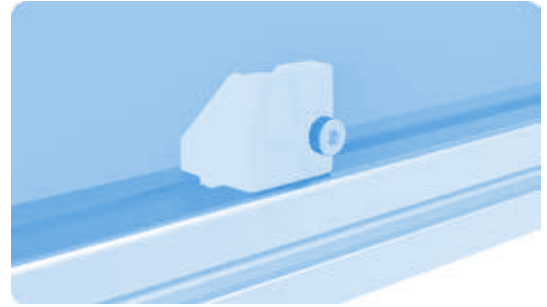
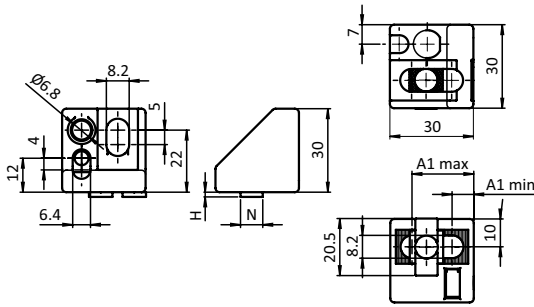

Uniblock ZN 40 CS	A1 max. [mm]	A1 min. [mm]	H [mm]	N	Gewinde Thread	Gewicht [g] Weight [g]	Teil-Nr. Part #
	22.0	8.0			M6	61.4	094Z40SCS
	22.0	8.0	1.7	8	M6	69.8	094Z40S0817CS
	22.0	8.0	4.0	8	M6	67.0	094Z40S0840CS
	22.0	8.0	4.0	10	M6	72.0	094Z40S1040CS



ABDECK- UND EINFASSPROFIL

COVER AND REDUCTION PROFILE

Ausführung	Kunststoff PP, Nut 5	Model	Plastic PP, slot 5
Beschreibung	zum Abdecken von Nuten mit Breite 5 mm und zum Einfassen von Flächenelementen mit 2 - 3 mm	Description	To cover size 5 profile slots and to secure panels with a thickness of 2 - 3 mm
Material	Kunststoff PP	Material	Plastic PP
Farbe	schwarz / natur	Color	Black / natural
Liefereinheit	200 Meter (100 Stück à 2 m)	Pack Quantity	200 meters (100 pieces at 2 m)
Extras	weitere Farben auf Anfrage	Specials	Other colors on request
Hinweis	Bitte beachten: Sie bestellen in Meter!	Tip	Please note: You are ordering in meters!

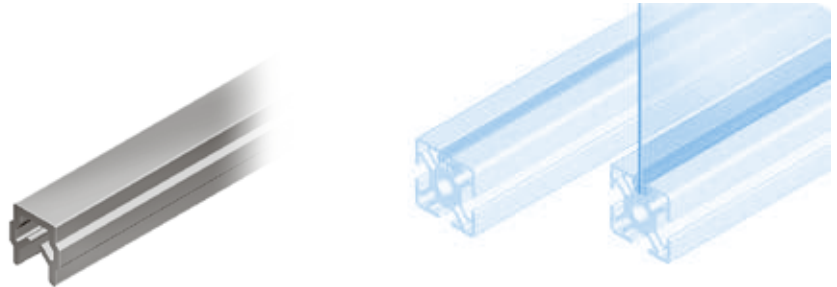
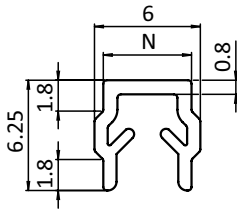

Abdeck- und Einfassprofil <i>Cover and Reduction Profile</i>	Nut Slot	Gewicht [g/m] Weight [g/m]	Profil Profile	Teil-Nr. Part #
schwarz <i>Black</i>	5	26.0	I	092045
natur <i>Natural</i>	5	26.0	I	092047

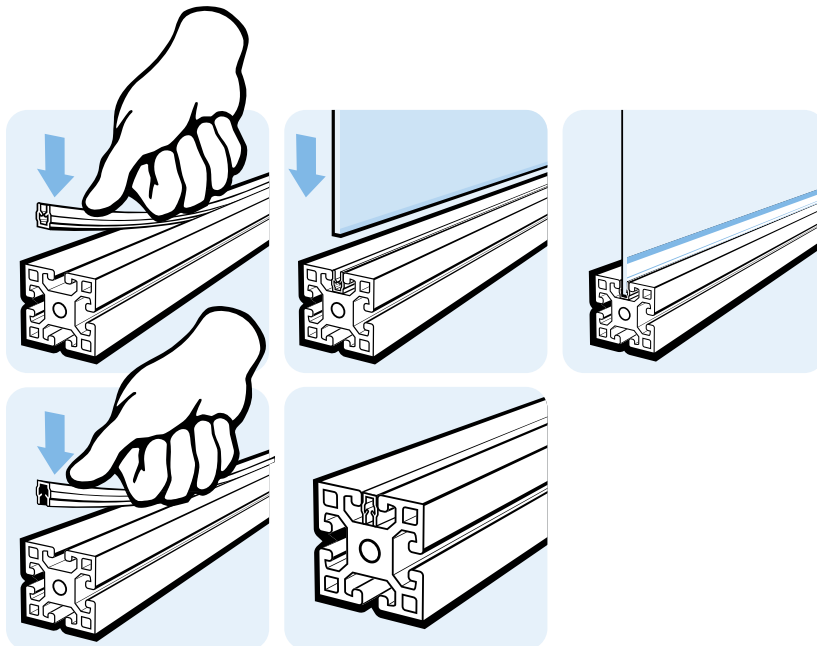

10



ABDECK- UND EINFASSPROFIL

COVER AND REDUCTION PROFILE

Ausführung	Kunststoff PP, Nut 6	Model	Plastic PP, slot 6
Beschreibung	zum Abdecken von Nuten mit Breite 6 mm und zum Einfassen von Flächenelementen mit 1 - 4 mm	Description	To cover size 6 profile slots and to secure panels with a thickness of 1 - 4 mm
Material	Kunststoff PP	Material	Plastic PP
Farbe	schwarz	Color	Black
Liefereinheit	200 Meter (100 Stück à 2 m)	Pack Quantity	200 meters (100 pieces at 2 m)
Extras	weitere Farben auf Anfrage	Specials	Other colors on request
Hinweis	Bitte beachten: Sie bestellen in Meter!	Tip	Please note: You are ordering in meters!

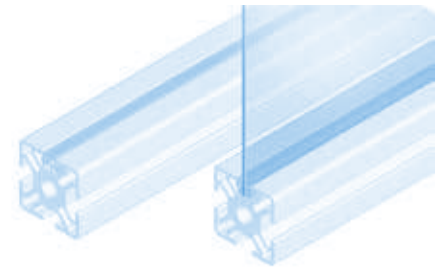
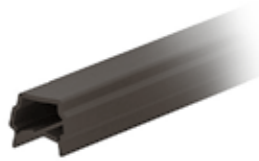
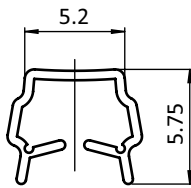

Abdeckprofil Cover Profile	Nut Slot	Gewicht [g/m] Weight [g/m]	Profil Profile	Teil-Nr. Part #
	6	17.0	B	092246

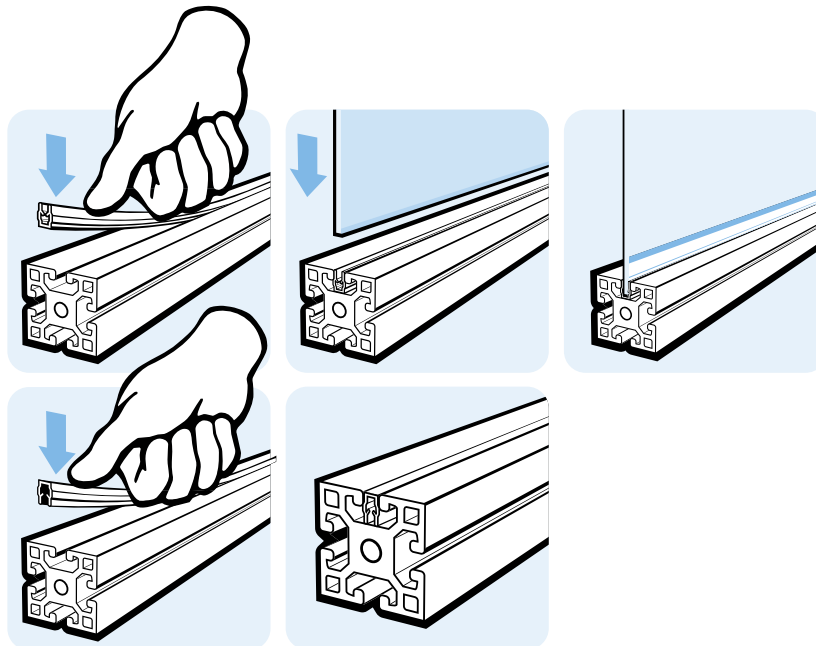



ABDECK- UND EINFASSPROFIL

COVER AND REDUCTION PROFILE

Ausführung	Kunststoff PP, Nut 6	Model	Plastic PP, slot 6
Beschreibung	zum Abdecken von Nuten mit Breite 6 mm und zum Einfassen von Flächenelementen mit 2 - 3,5 mm	Description	To cover size 6 profile slots and to secure panels with a thickness of 2 - 3.5 mm
Material	Kunststoff PP	Material	Plastic PP
Farbe	schwarz, natur, grau	Color	Black, natural, gray
Liefereinheit	200 Meter (100 Stück à 2 m)	Pack Quantity	200 meters (100 pieces at 2 m)
Extras	weitere Farben auf Anfrage	Specials	Other colors on request
Hinweis	Bitte beachten: Sie bestellen in Meter!	Tip	Please note: You are ordering in meters!

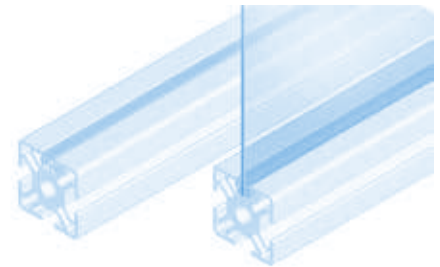
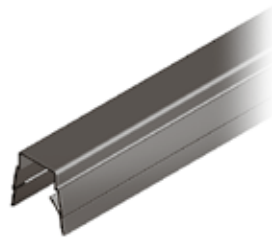
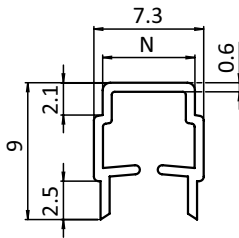

Abdeck- und Einfassprofil <i>Cover and Reduction Profile</i>	Nut <i>Slot</i>	Gewicht [g/m] <i>Weight [g/m]</i>	Profil <i>Profile</i>	Teil-Nr. <i>Part #</i>
schwarz <i>Black</i>	6	26.0	I	092033
natur <i>Natural</i>	6	26.0	I	092034
grau ≈ RAL 7035 <i>Gray</i>	6	26.0	I	092033S01

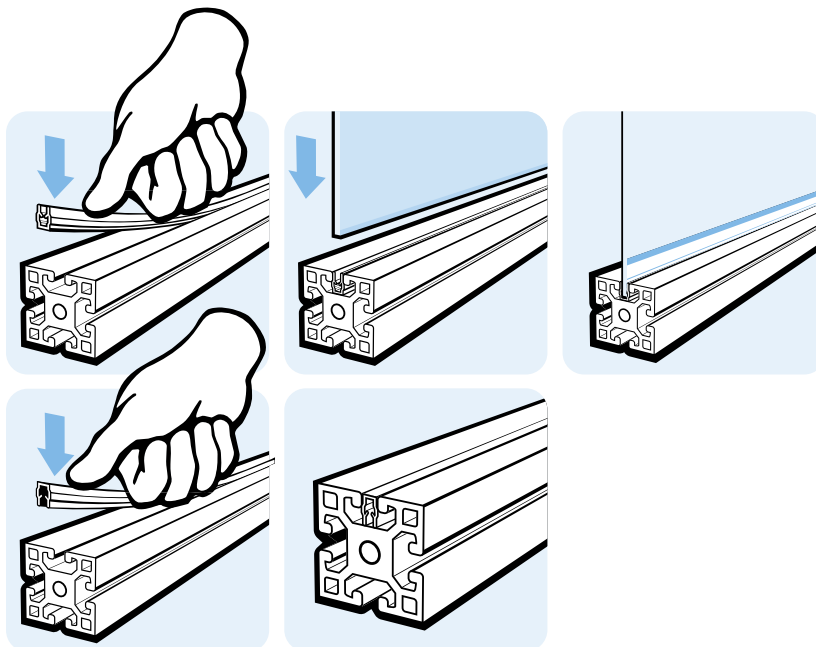



ABDECK- UND EINFASSPROFIL

COVER AND REDUCTION PROFILE

Ausführung	Kunststoff PP, Nut 8	Model	Plastic PP, slot 8
Beschreibung	zum Abdecken von Nuten mit Breite 8 mm und zum Einfassen von Flächenelementen mit 4 - 6 mm	Description	To cover size 8 profile slots and to secure panels with a thickness of 4 - 6 mm
Material	Kunststoff PP	Material	Plastic PP
Farbe	schwarz, natur, grau, rot, blau, gelb, weißaluminium	Color	Black, natural, gray, red, blue, yellow, white aluminum
Liefereinheit	200 Meter (100 Stück à 2 m)	Pack Quantity	200 meters (100 pieces at 2 m)
Extras	weitere Farben auf Anfrage	Specials	Other colors on request
Hinweis	Bitte beachten: Sie bestellen in Meter!	Tip	Please note: You are ordering in meters!

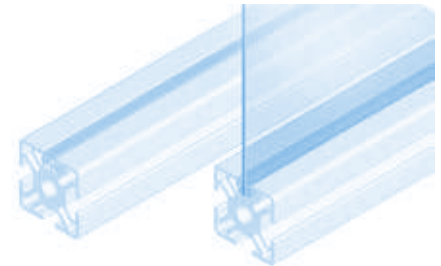
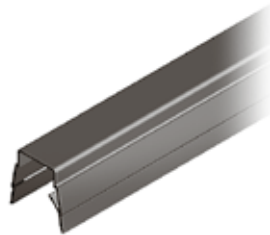
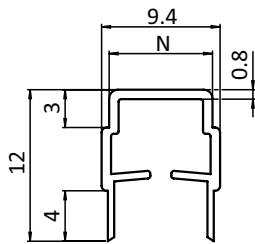

Abdeck- und Einfassprofil <i>Cover and Reduction Profile</i>	Nut Slot	Gewicht [g/m] Weight [g/m]	Profil Profile	Teil-Nr. Part #
schwarz <i>Black</i>	8	26.0	I	092031
natur <i>Natural</i>	8	26.0	I	092030
grau ≈ RAL 7035 <i>Gray</i>	8	26.0	I	092035
rot ≈ RAL 3020 <i>Red</i>	8	26.0	I	092036
blau ≈ RAL 5005 <i>Blue</i>	8	26.0	I	092037
gelb ≈ RAL 1018 <i>Yellow</i>	8	26.0	I	092031S03
weißaluminium ≈ RAL 9006 <i>White aluminum</i>	8	26.0	I	092031S04

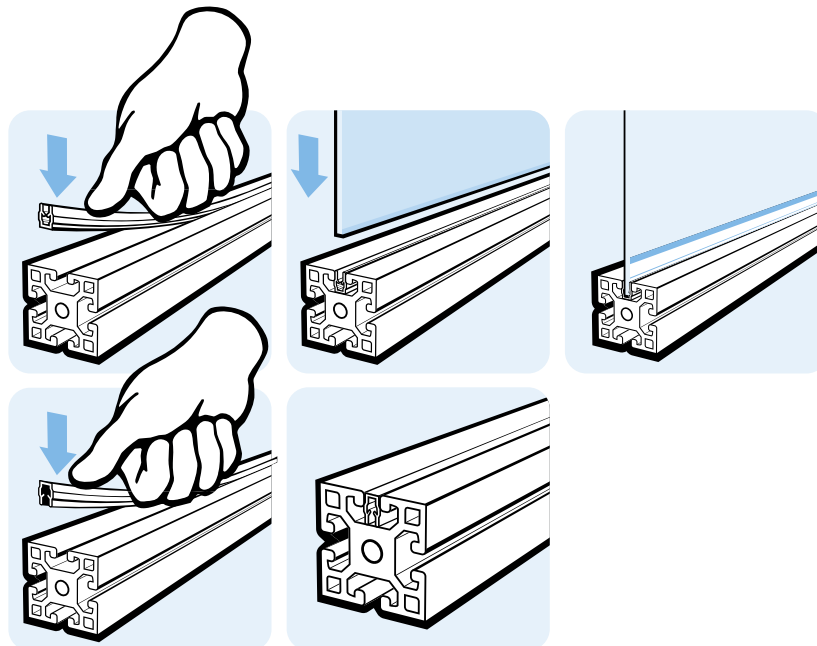



ABDECK- UND EINFASSPROFIL

COVER AND REDUCTION PROFILE

Ausführung	Kunststoff PP + TPE, Nut 8	Model	Plastic PP + TPE, slot 8
Beschreibung	zum Abdecken von Nuten mit Breite 8 mm und zum Einfassen von Flächenelementen mit 4 - 6 mm	Description	To cover size 8 profile slots and to secure panels with a thickness of 4 - 6 mm
Material	Kunststoff PP + TPE	Material	Plastic PP + TPE
Farbe	schwarz	Color	Black
Liefereinheit	200 Meter (100 Stück à 2 m)	Pack Quantity	200 meters (100 pieces at 2 m)
Extras	weitere Farben auf Anfrage	Specials	Other colors on request
Hinweis	Bitte beachten: Sie bestellen in Meter!	Tip	Please note: You are ordering in meters!

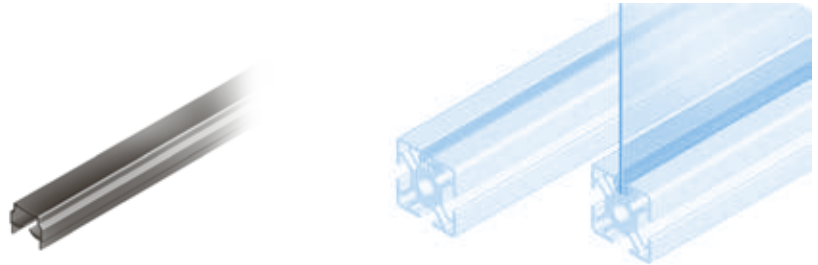
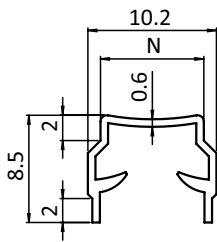

Abdeck- und Einfassprofil <i>Cover and Reduction Profile</i>	Nut <i>Slot</i>	Gewicht [g/m] <i>Weight [g/m]</i>	Profil <i>Profile</i>	Teil-Nr. <i>Part #</i>
	8	25.0	B	092242

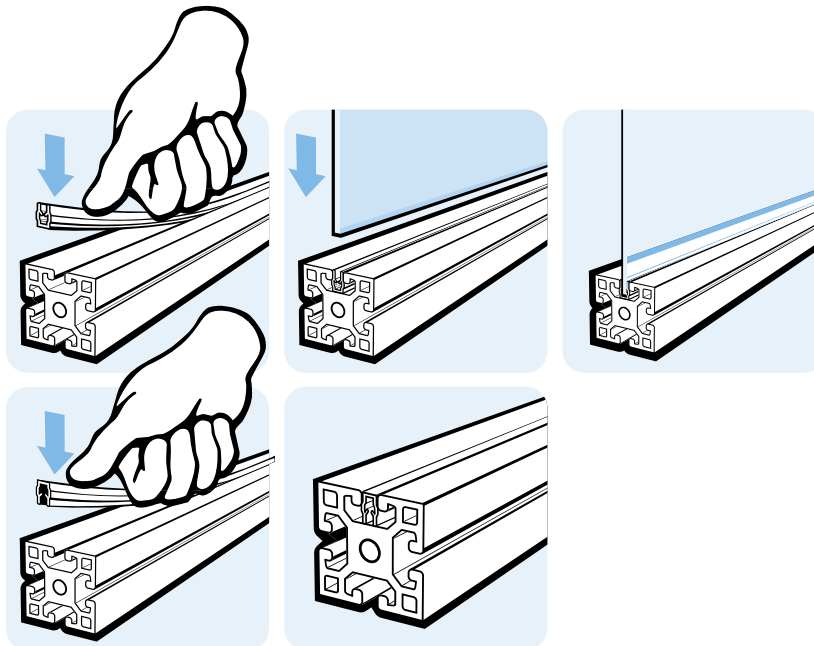



EINFASSPROFIL

REDUCTION PROFILE

Ausführung	Kunststoff PP + TPE, Nut 10	Model	Plastic PP + TPE, slot 10
Beschreibung	zum Einfassen von Flächenelementen mit 2 - 6 mm	Description	To secure panels with a thickness of 2 - 6 mm
Material	Kunststoff PP + TPE	Material	Plastic PP + TPE
Farbe	schwarz	Color	Black
Liefereinheit	200 Meter (100 Stück à 2 m)	Pack Quantity	200 meters (100 pieces at 2 m)
Extras	weitere Farben auf Anfrage	Specials	Other colors on request
Hinweis	Bitte beachten: Sie bestellen in Meter!	Tip	Please note: You are ordering in meters!

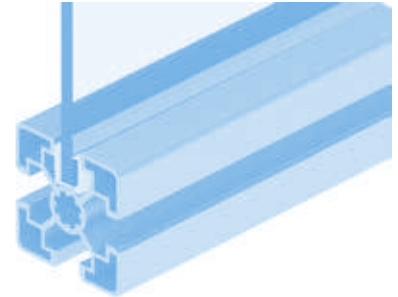
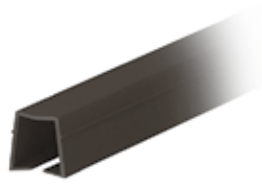
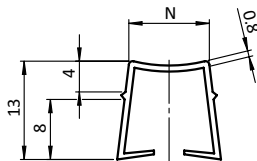

Einfassprofil Reduction Profile	Nut 10 Slot 10	Gewicht [g/m] Weight [g/m]	Profil Profile	Teil-Nr. Part #
	10	39.0	B	092260

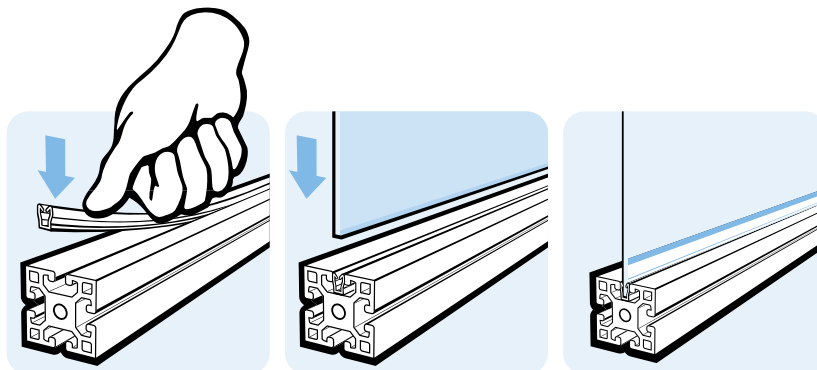



ABDECK- UND EINFASSPROFIL

COVER AND REDUCTION PROFILE

Ausführung	Kunststoff PP + TPE, Nut 10	Model	Plastic PP + TPE, slot 10
Beschreibung	zum Abdecken von Nuten mit Breite 10 mm und zum Einfassen von Flächenelementen mit 2 - 6 mm	Description	To cover size 10 profile slots and to secure panels with a thickness of 2 - 6 mm
Material	Kunststoff PP + TPE	Material	Plastic PP + TPE
Farbe	schwarz	Color	Black
Liefereinheit	200 Meter (100 Stück à 2 m)	Pack Quantity	200 meters (100 pieces at 2 m)
Extras	weitere Farben auf Anfrage	Specials	Other colors on request
Hinweis	Bitte beachten: Sie bestellen in Meter!	Tip	Please note: You are ordering in meters!

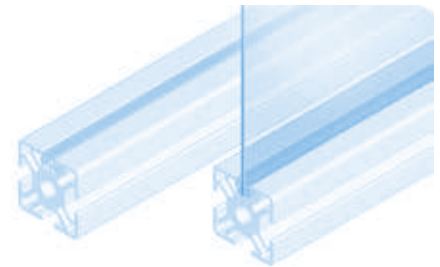
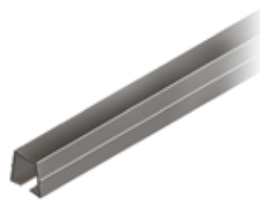
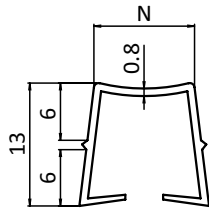

Abdeck- und Einfassprofil <i>Cover and Reduction Profile</i>	Nut <i>Slot</i>	Gewicht [g/m] <i>Weight [g/m]</i>	Profil <i>Profile</i>	Teil-Nr. <i>Part #</i>
	10	34.0	B	092243

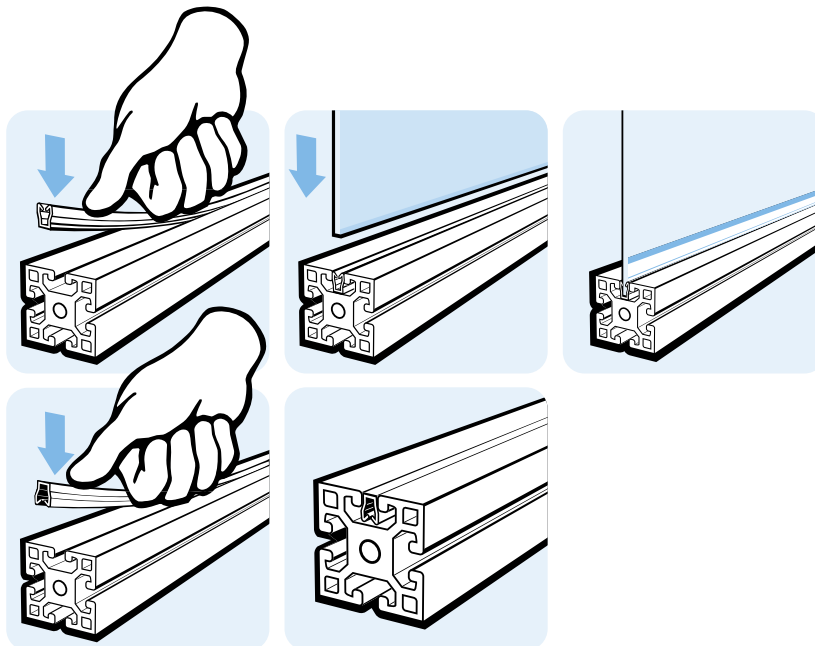

10



EINFASSPROFIL

REDUCTION PROFILE

Ausführung	Kunststoff PE, Nut 10	Model	Plastic PE, slot 10
Beschreibung	zum Einfassen von Flächenelementen mit 6 mm	Description	To secure panels with a thickness of 6 mm
Material	Kunststoff PE	Material	Plastic PE
Farbe	schwarz	Color	Black
Liefereinheit	100 Meter (50 Stück à 2m)	Pack Quantity	100 meters (50 pieces at 2 m)
Hinweis	Bitte beachten: Sie bestellen in Meter!	Tip	Please note: You are ordering in meters!

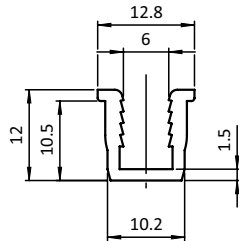

Einfassprofil <i>Reduction Profile</i>	Nut <i>Slot</i>	Gewicht [g/m] <i>Weight [g/m]</i>	Profil <i>Profile</i>	Teil-Nr. <i>Part #</i>
	10	110.3	B	092094



EINSETZPROFIL PVC

INSERT PROFILE PVC

Ausführung	Kunststoff PVC + TPE, Nut 8, 10, nachträglich einsetzbar	Model	Plastic PVC + TPE, slot 8, 10, subsequently insertable
Beschreibung	zum nachträglichen Einsetzen von Flächenelementen mit 1,5 - 8,0 mm	Description	To insert panels with 1.5 to 8.0 mm thickness subsequently into assembled structures
Material	Kunststoff PVC + TPE	Material	Plastic PVC + TPE
Farbe	schwarz	Color	Black
Liefereinheit	50 Meter (25 St. à 2m)	Pack Quantity	50 meters (25 pieces at 2 m)
Hinweis	Bitte beachten: Sie bestellen in Meter!	Tip	Please note: You are ordering in meters!

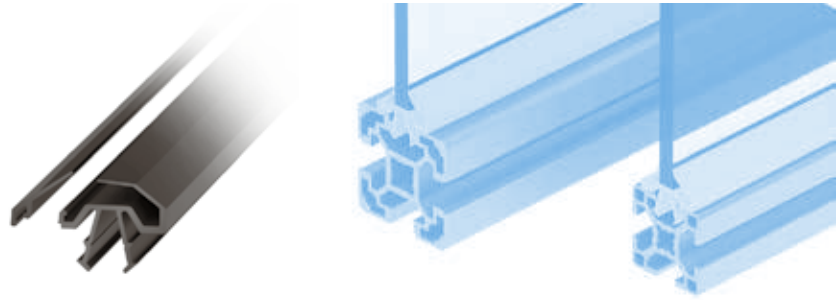
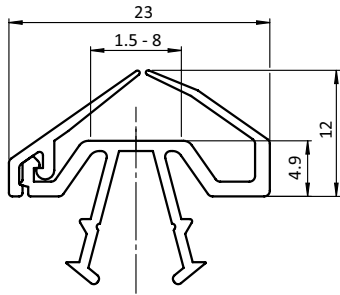

Einsetzprofil PVC <i>Insert Profile PVC</i>	Nut <i>Slot</i>	Nut 10 <i>Slot 10</i>	Nut 8 <i>Slot 8</i>	Gewicht [g/m] <i>Weight [g/m]</i>	Profil <i>Profile</i>	Teil-Nr. <i>Part #</i>
	8 + 10	10	8	41.0	B	092251



EINFASSPROFIL

HOLDER PROFILE

Ausführung	Kunststoff PP + TPE, Nut 10, nachträglich einsetzbar	Model	Plastic PP + TPE, slot 10, subsequently insertable
Beschreibung	zum nachträglichen Einsetzen von Flächenelementen mit 2,0 - 10,0 mm, schafft eine spritzwasser- und staubdichte Verbindung	Description	For subsequent insertion of panels of size 2.0 - 10.0 mm, creates a sealed connection against spray water and dust
Material	Kunststoff PP + TPE	Material	Plastic PP + TPE
Farbe	schwarz	Color	Black
Liefereinheit	50 Meter (25 St. à 2m)	Pack Quantity	50 meters (25 pieces at 2 m)
Hinweis	Bitte beachten: Sie bestellen in Meter!	Tip	Please note: You are ordering in meters!

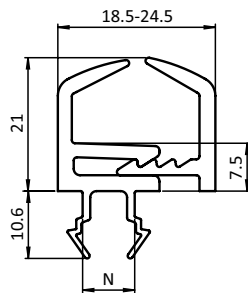

Einfassprofil Holder Profile	Nut Slot	Gewicht [g/m] Weight [g/m]	Profil Profile	Teil-Nr. Part #
	10	43.5	B	092244

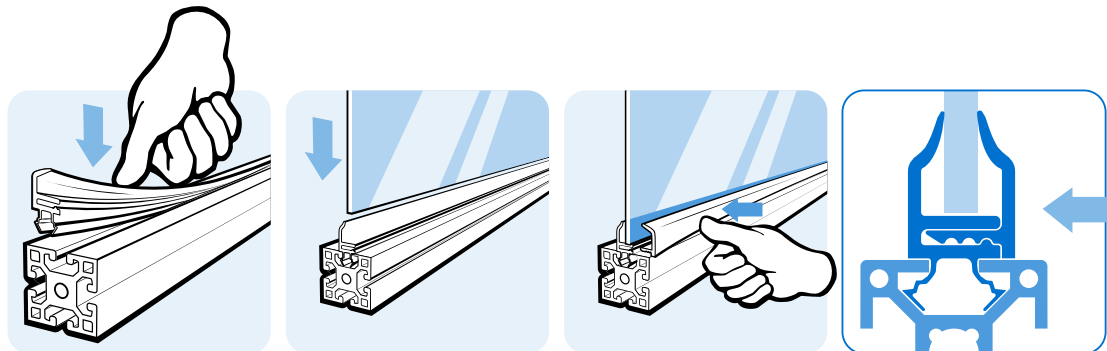



EINSETZPROFIL AL

INSERT PROFILE AL

Ausführung	Aluminium und Kunststoff PP + TPE, Nut 10, nachträglich einsetzbar	Model	Aluminum and Plastics PP + TPE, slot 10, subsequently insertable
Beschreibung	zum nachträglichen Einsetzen von Flächenelementen mit 2,0 - 8,0 mm	Description	To insert panels with 2.0 to 8.0 mm thickness subsequently into assembled structures
Material	Grundprofil AL: Aluminium Cipleiste: PP + TPE	Material	Support strip AL: Aluminum Glazing strip: PP + TPE
Farbe	Cipleiste: grau ≈ RAL 7035	Color	Glazing strip: gray ≈ RAL 7035
Liefereinheit	20 Meter (10 Stück à 2 m)	Pack Quantity	20 meters (10 pieces at 2 m)
Hinweis	Bitte beachten: Sie bestellen in Meter!; Für ein komplettes Einsetzprofil AL bitte zwei Artikel bestellen: Grundprofil AL 092252 + Cipleiste 092254	Tip	Please note: You are ordering in meters! For a complete insert profile, please order two products: support strip AL 092252 + glazing strip 092254

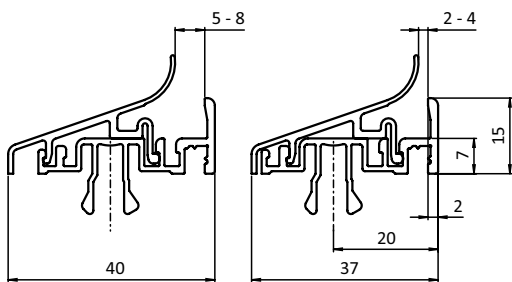

Einsetzprofil AL Insert Profile AL	Nut 10 Slot 10	Gewicht [g] Weight [g]	Profil Profile	Teil-Nr. Part #
Grundprofil AL <i>Support strip AL</i>	10	240.0	B	092252
Cipleiste <i>Glazing strip</i>	10	60.0	B	092253



SCHEIBENDICHTUNG

PLUG-IN PROFILE

Ausführung	Kunststoff EPDM, Nut 8	Model	Plastic EPDM, slot 8
Beschreibung	zur Fixierung und Abdichtung von Flächenelementen in der Nut; die reduzierte Oberflächenreibung erleichtert die Montage	Description	To secure panels in the slot and fill the slot; with reduced surface friction to ease the application
Material	Kunststoff EPDM mit Gleitpolymer	Material	Plastic EPDM coated with sliding polymer
Farbe	schwarz	Color	Black
Liefereinheit	100 Meter (100 St. à 1 m)	Pack Quantity	100 meters (100 pieces at 1 m)
Hinweis	Bitte beachten: Sie bestellen in Meter! *vor Montage mit Seifenwasser benetzen	Tip	Please note: You are ordering in meters! *Best wetted with soapy water prior to assembly

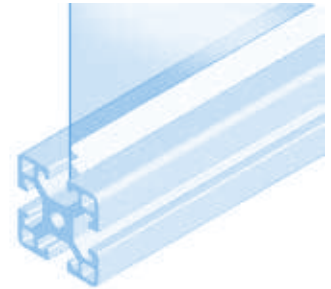
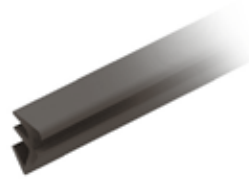
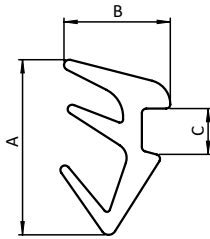

Scheibendichtung Plug-in Profile	A [mm]	B [mm]	C [mm]	für Scheibe for Panel	Nut Slot	Gewicht [g/m] Weight [g/m]	Profil Profile	Teil-Nr. Part #
	11.6	7.0	3.0	4 – 5 (6*) mm	8	37.0	B	092256

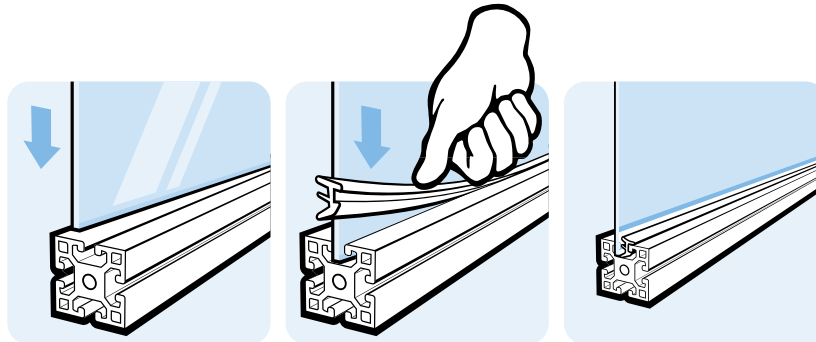



SCHEIBENDICHTUNG

PLUG-IN PROFILE

Ausführung	Kunststoff EPDM, Nut 8+10	Model	Plastic EPDM, slot 8+10
Beschreibung	zur Fixierung und Abdichtung von Flächenelementen in der Nut; die reduzierte Oberflächenreibung erleichtert die Montage	Description	To secure panels in the slot and fill the slot; with reduced surface friction to ease the application
Material	Kunststoff EPDM mit Gleitpolymer	Material	Plastic EPDM coated with sliding polymer
Farbe	schwarz	Color	Black
Liefereinheit	100 Meter (100 St. à 1 m)	Pack Quantity	100 meters (100 pieces at 1 m)
Hinweis	Bitte beachten: Sie bestellen in Meter!	Tip	Please note: You are ordering in meters!

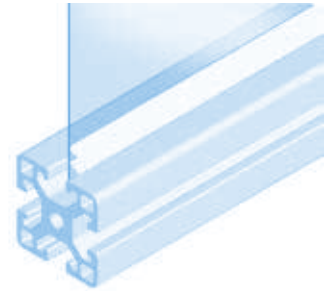
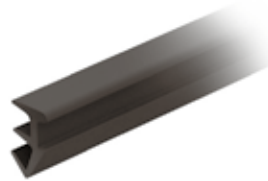
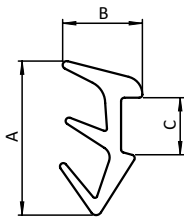

Scheibendichtung Plug-in Profile	A [mm]	B [mm]	C [mm]	für Scheibe for Panel	Nut Slot	Gewicht [g/m] Weight [g/m]	Profil Profile	Teil-Nr. Part #
	14.7	8.6	5.0	2 – 4 mm / 4 - 6 mm	8 / 10	53.0	I	092255
	13.5	7.0	5.0	4 – 6 mm / 6 - 7 mm	8 / 10	40.0	I	092254

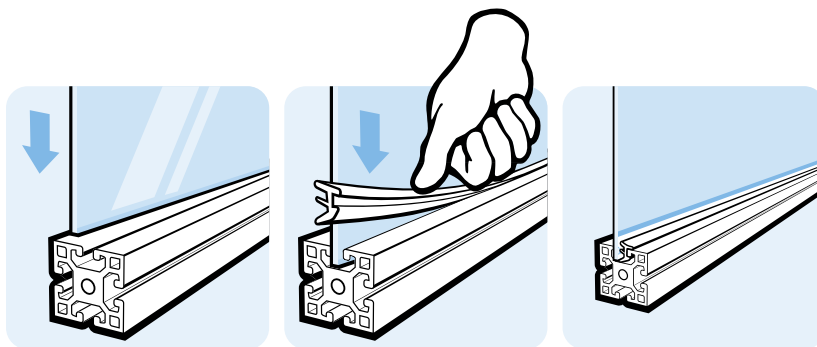



SCHEIBENDICHTUNG

PLUG-IN PROFILE

Ausführung	Kunststoff TPE, Nut 8+10	Model	Plastic TPE, slot 8+10
Beschreibung	zur Fixierung und Abdichtung von Flächenelementen in Nuten	Description	To secure panels in the slot and fill the slot
Material	Kunststoff TPE	Material	Plastic TPE
Farbe	schwarz, grau	Color	Black, gray
Liefereinheit	100 Meter (Rolle)	Pack Quantity	100 meters (spool)
Extras	weitere Farben auf Anfrage	Specials	Other colors on request
Hinweis	Bitte beachten: Sie bestellen in Meter! *vor Montage mit Seifenwasser benetzen	Tip	Please note: You are ordering in meters! *Best wetted with soapy water prior to assembly

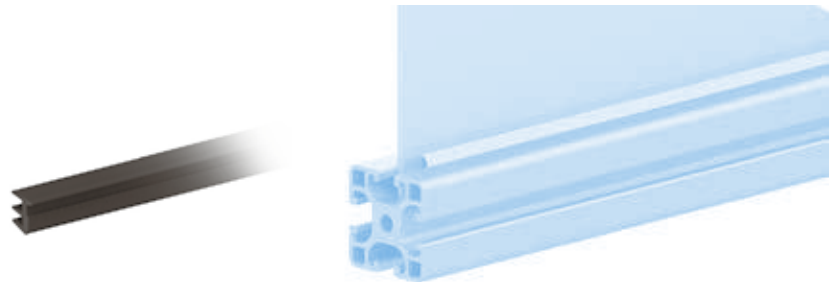
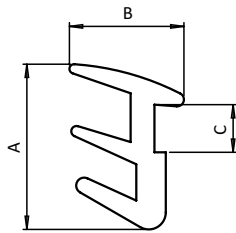

Scheibendichtung Plug-in Profile	A [mm]	B [mm]	C [mm]	für Scheibe for Panel	Nut Slot	Gewicht [g/m] Weight [g/m]	Profil Profile	Teil-Nr. Part #
schwarz <i>Black</i>	14.6	10.1	4.2	2 - 4 mm / 4 - 5 (6*) mm	8 / 10	90.0	I	092093
grau ≈ RAL 7042 <i>Gray</i>	14.6	10.1	4.2	2 - 4 mm / 4 - 5 (6*) mm	8 / 10	90.0	I	092093S02

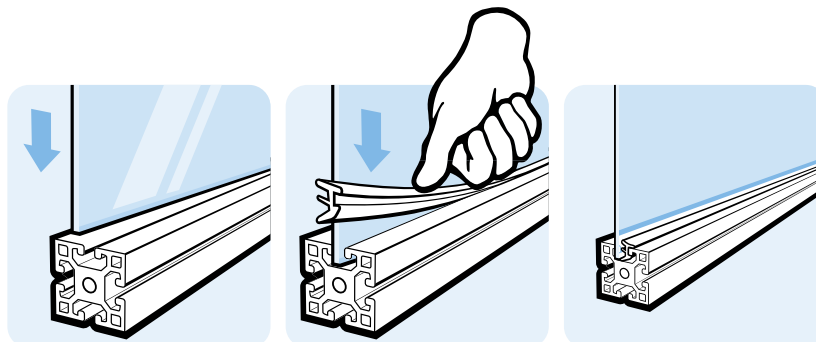



SCHEIBENDICHTUNG

PLUG-IN PROFILE

Ausführung	Kunststoff TPE, Nut 8+10	Model	Plastic TPE, slot 8+10
Beschreibung	zur Fixierung und Abdichtung von Flächenelementen in der Nut	Description	To secure panels in the slot and fill the slot
Material	Kunststoff TPE	Material	Plastic TPE
Farbe	schwarz	Color	Black
Liefereinheit	100 Meter (Rolle)	Pack Quantity	100 meters (spool)
Extras	weitere Farben auf Anfrage	Specials	Other colors on request
Hinweis	Bitte beachten: Sie bestellen in Meter! *vor Montage mit Seifenwasser benetzen	Tip	Please note: You are ordering in meters! *Best wetted with soapy water prior to assembly

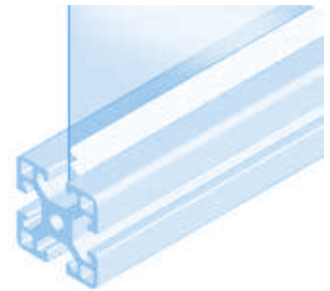
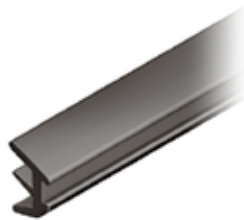
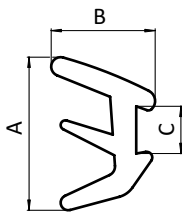

Scheibendichtung Plug-in Profile	A [mm]	B [mm]	C [mm]	für Scheibe for Panel	Nut Slot	Gewicht [g/m] Weight [g/m]	Profil Profile	Teil-Nr. Part #
	18.0	11.8	6.9	2 - 4 mm / 4 - 6 mm / 4 (5*) mm	8 / 10 / 10	70.0	I / I / B	092065

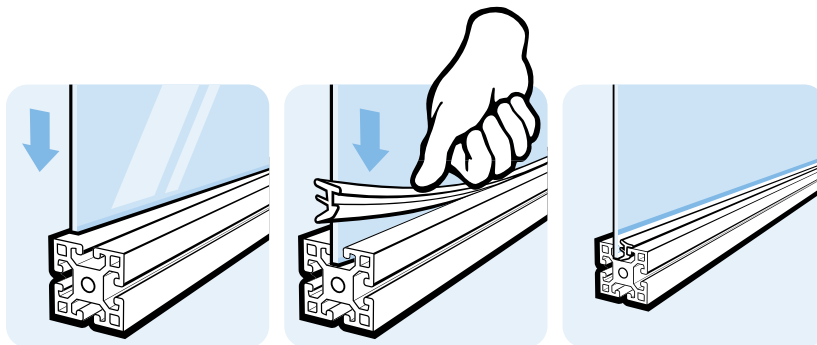



SCHEIBENDICHTUNG

PLUG-IN PROFILE

Ausführung	Kunststoff TPE, Nut 5, 6, 8, 10	Model	Plastic TPE, slot 5, 6, 8, 10
Beschreibung	zur Fixierung und Abdichtung von Flächenelementen in der Nut	Description	To secure panels in the slot and fill the slot
Material	Kunststoff TPE	Material	Plastic TPE
Farbe	schwarz	Color	Black
Liefereinheit	100 Meter (Rolle)	Pack Quantity	100 meters (spool)
Extras	weitere Farben auf Anfrage	Specials	Other colors on request
Hinweis	Bitte beachten: Sie bestellen in Meter! *vor Montage mit Seifenwasser benetzen	Tip	Please note: You are ordering in meters! *Best wetted with soapy water prior to assembly

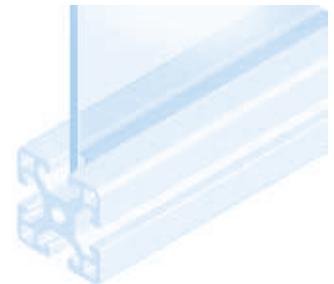
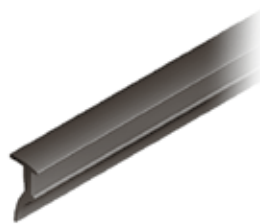
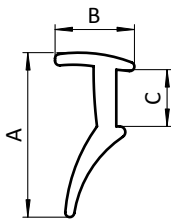

Scheibendichtung Plug-in Profile	A [mm]	B [mm]	C [mm]	für Scheibe for Panel	Nut Slot	Gewicht [g/m] Weight [g/m]	Profil Profile	Teil-Nr. Part #
	7.6	6.2	1.9	2 - 3 mm	5	16.0	I	092063
	8.7	7.0	3.0	2 - 3 (4*) mm	6	20.0	I	092064
	14.0	7.0	4.7	4 - 6 mm / 6 - 7 (8*) mm	8 / 10	30.8	I / I	092066

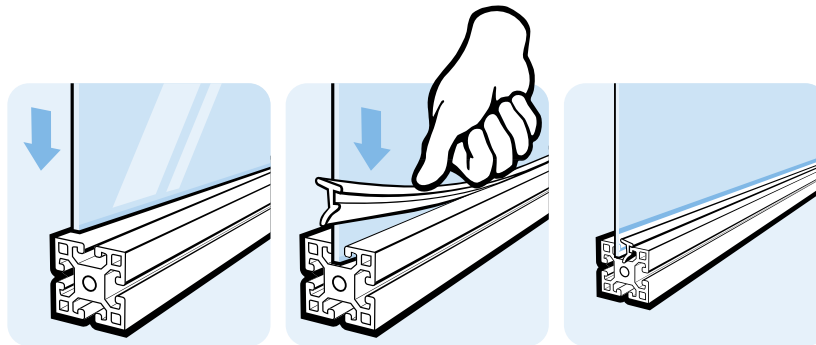

KLEMMFEDERBLECH

CLAMPING SPRING

Ausführung	Edelstahl, für Klemmnut 10	Model	Stainless steel, for clamp slot 10
Beschreibung	zur Befestigung von Flächenelementen 2 - 9 mm in der Nut	Description	To fix panels 2 - 9 mm in the slot
Material	Edelstahl 1.4305	Material	Stainless steel SS303
Länge	80 mm	Length	80 mm
Liefereinheit	100 Stück à 80 mm	Pack Quantity	100 pieces at 80 mm

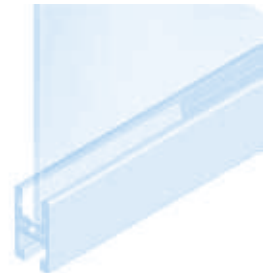
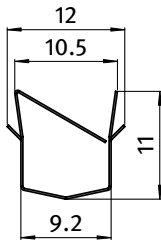

Klemmfederblech <i>Clamping Spring</i>	Gewicht [g] <i>Weight [g]</i>	Profil <i>Profile</i>	Teil-Nr. <i>Part #</i>
	4.0	I	092090

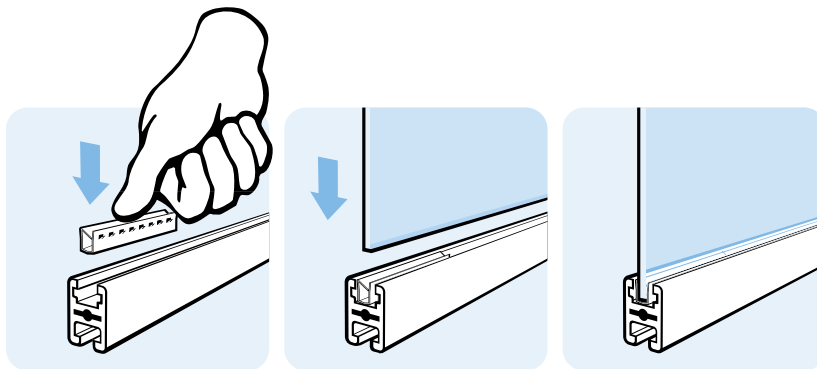



KLEMMFEDERBLECH

CLAMPING SPRING

Ausführung	Federstahl	Model	Spring steel
Beschreibung	zur Befestigung von Flächenelementen 2 - 4 mm in der Klemmnut für Wellengitter Ø 3 mm, oder 4 - 5 mm in der Klemmnut für Wellengitter Ø 4 mm; empfohlene Anzahl: ca. 4 Stück auf 1 m	Description	To fix panels 2 - 4 mm in a clamp slot for Ø 3 mm wire mesh frames, or panels 4 - 5 mm in a clamp slot for Ø 4 mm wire mesh frames; recommended number: ca. 4 pcs. per 1 m
Material	Federstahl 1.1211	Material	Spring steel C60S
Länge	45 mm	Length	45 mm
Liefereinheit	100 Stück à 45 mm	Pack Quantity	100 pieces at 45 mm

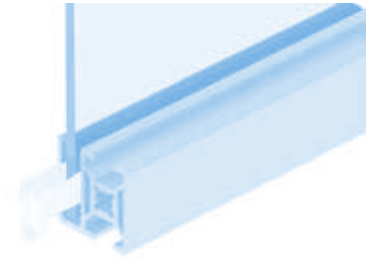
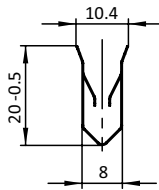

Klemmfederblech
Clamping Spring

Gewicht [g]
Weight [g]

Profil
Profile

Teil-Nr.
Part #

3.0

B

092096

GLASSCHEIBENHALTER

GLASS PANEL CLAMP

Ausführung	Zinkdruckguss, mit Montageset	Model	Zinc die-cast, with assembly set
Beschreibung	zur Befestigung von Glasscheiben und anderen Flächenelementen	Description	To fix glass and other panels
Material	Zinkdruckguss	Material	Zinc die-cast
Set	1 Glasscheibenhalter, 1 Schraube M5 x 16, 5 Gummis für Platten von 2 bis 9 mm	Set	1 glass panel clamp, 1 screw M5 x 16, 5 rubber pads for panels 2 - 9 mm
Liefereinheit	10 Stück	Pack Quantity	10 pieces
Extras	weitere Oberflächen, weitere Farben auf Anfrage	Specials	Other surfaces, other colors on request

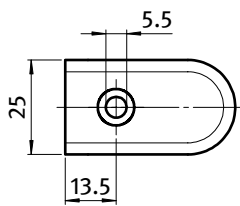
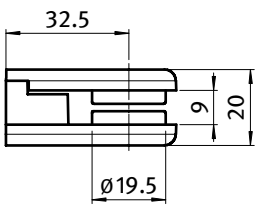

Glasscheibenhalter
Glass Panel Clamp

Gewicht [g]
Weight [g]

Teil-Nr.
Part #

Set

74.0

093310

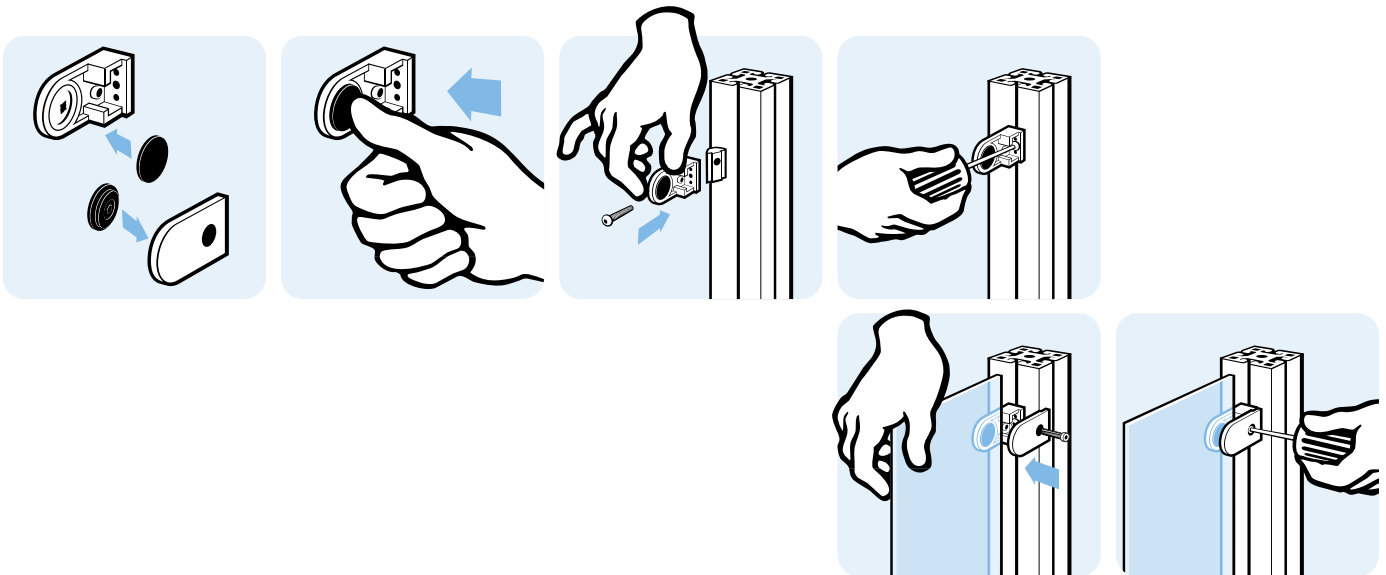

ECKVERBINDER

CORNER CONNECTOR

Ausführung	für Glasscheibenhalter, Zinkdruckguss	Model	For glass panel clamp, zinc die-cast
Beschreibung	zur Eckverbindung von zwei Glasscheiben mittels Glasscheibenhaltern (2 Sets)	Description	To make a corner connection with two panels using two glass panel clamps (2 sets)
Material	Zinkdruckguss	Material	Zinc die-cast
Set	1 Eckverbinder, 2 Schrauben M5 x 12	Set	1 corner connector, 2 screws M5 x 12
Liefereinheit	10 Stück	Pack Quantity	10 pieces
Extras	weitere Oberflächen, weitere Farben auf Anfrage	Specials	Other surfaces, other colors on request

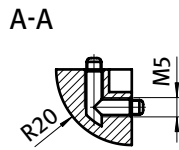
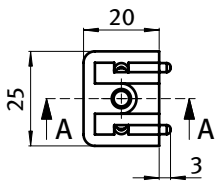

Eckverbinder für Glasscheibenhalter
Corner Connection for Glass Panel Clamp

Gewicht [g]
Weight [g]

Teil-Nr.
Part #

Set

37.0

093320

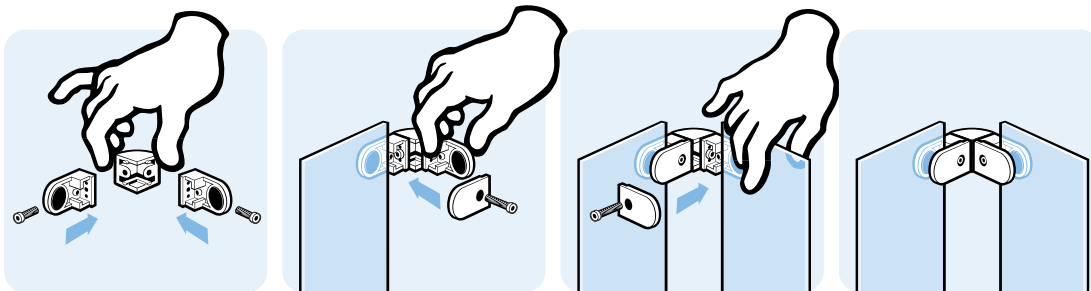

PLATTENHALTER

PANEL HOLDER

Ausführung Aluminium	Model Aluminum
Beschreibung zur einfachen Befestigung von Flächenelementen an Aluminiumprofilen	Description To attach panels easily to aluminum profiles
Material Aluminium	Material Aluminum
Liefereinheit 10 Stück	Pack Quantity 10 pieces

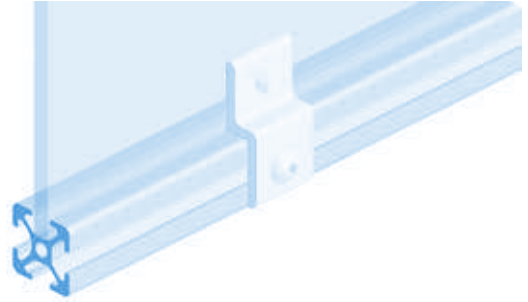
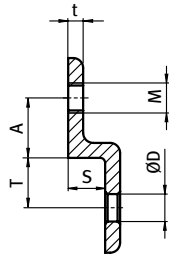
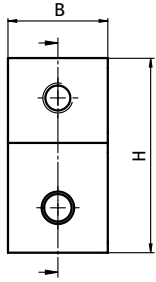



























Plattenhalter Panel Holder	A [mm]	B [mm]	H [mm]	M	ØD [mm]	S [mm]	T [mm]	für Profil for Profile	Gewicht [g] Weight [g]	Teil-Nr. Part #
	12.0	20.0	39.0	M6	5.5	7.4	10.0	20	10.0	093P20N
	23.0	30.0	68.0	M8	9.0	11.0	15.0	30	36.3	093P30N
	24.0	40.0	78.0	M8	9.0	16.0	20.0	40	60.0	093P40N
	26.5	45.0	88.0	M8	9.0	17.5	22.5	45	75.0	093P45N

INHALTSÜBERSICHT *CONTENT OVERVIEW*



Bodenelemente <i>Floor Elements</i>	1
Scharniere <i>Hinges</i>	2
Nutmuttern und -schrauben <i>T-Nuts and T-Bolts</i>	3
Verbindungstechnik <i>Connecting Systems</i>	4
Griffe und Verschlüsse <i>Handles and Latches</i>	5
Arbeitsplatzkomponenten <i>Components for Work Stations</i>	6
Gleiter und Rollen <i>Sliders and Rollers</i>	7
Fördertechnik <i>Conveyors</i>	8
Schutz- und Trennwandelemente <i>Enclosures, Guards, Partitions</i>	9
Flächenbefestigungen <i>Panel Fasteners</i>	10
Abdeckelemente <i>Cover Elements</i>	11
Kabelführungen <i>Cable Management</i>	12
Diverse Komponenten <i>Miscellaneous Components</i>	13
Rundrohrkomponenten <i>Tubular Frame Components</i>	14

	Abdeck- und Einfassprofil	<i>Cover and Reduction Profile</i>	719		Abdeckkappen für Schutzgitterprofile	<i>Cover Caps for Wire Mesh Frame Profiles</i>	738
	Abdeck- und Einfassprofil	<i>Cover and Reduction Profile</i>	720		Abdeckkappen anschraubbar	<i>Cover Caps Screw-on Type</i>	739
	Abdeck- und Einfassprofil	<i>Cover and Reduction Profile</i>	721		Abdeckkappen ZN anschraubbar	<i>Cover Caps ZN Screw-on Type</i>	740
	Abdeckprofil	<i>Cover Profile</i>	722		Kanal-Abdeckkappen	<i>Conduit Caps</i>	741
	Abdeck- und Einfassprofil	<i>Cover and Reduction Profile</i>	723		Abdeckkappe für Einhängprofil	<i>Cover Cap for Suspension Profile</i>	742
	Abdeck- und Einfassprofil	<i>Cover and Reduction Profile</i>	724		Abdeckkappen	<i>Cover Caps</i>	743
	Abdeckprofil	<i>Cover Profile</i>	725		Clip 8	<i>Clip 8</i>	744
	Abdeckprofil	<i>Cover Profile</i>	726				
	Abdeckprofil	<i>Cover Profile</i>	727				
	Abdeckprofil	<i>Cover Profile</i>	728				
	Abdeckprofil	<i>Cover Profile</i>	729				
	Abdeckprofil	<i>Cover Profile</i>	730				
	Abdeckkappe für Rastermaß 20 mm	<i>Cover Cap for 20 mm Modular Dimension</i>	731				
	Abdeckkappe für Rastermaß 30 mm	<i>Cover Cap for 30 mm Modular Dimension</i>	732				
	Abdeckkappe für Rastermaß 40 mm	<i>Cover Cap for 40 mm Modular Dimension</i>	733				
	Abdeckkappe für Rastermaß 45 mm	<i>Cover Cap for 45 mm Modular Dimension</i>	734				
	Abdeckkappe für Klemmprofil	<i>Cover Cap for Clamp Profile</i>	735				
	Abdeckkappe für Rastermaß 60 mm	<i>Cover Cap for 60 mm Modular Dimension</i>	736				
	Abdeckkappe für Klemmprofil	<i>Cover Cap for Clamp Profile</i>	737				



ABDECK- UND EINFASSPROFIL

COVER AND REDUCTION PROFILE

Ausführung	Kunststoff PP, Nut 5	Model	Plastic PP, slot 5
Beschreibung	zum Abdecken von Nuten mit Breite 5 mm und zum Einfassen von Flächenelementen mit 2 - 3 mm	Description	To cover size 5 profile slots and to secure panels with a thickness of 2 - 3 mm
Material	Kunststoff PP	Material	Plastic PP
Farbe	schwarz / natur	Color	Black / natural
Liefereinheit	200 Meter (100 Stück à 2 m)	Pack Quantity	200 meters (100 pieces at 2 m)
Extras	weitere Farben auf Anfrage	Specials	Other colors on request
Hinweis	Bitte beachten: Sie bestellen in Meter!	Tip	Please note: You are ordering in meters!

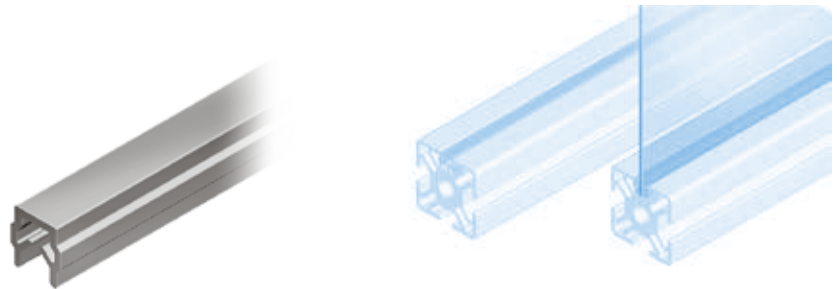
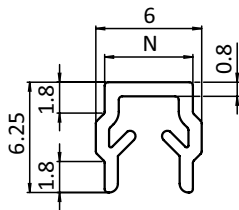

Abdeck- und Einfassprofil <i>Cover and Reduction Profile</i>	Nut <i>Slot</i>	Gewicht [g/m] <i>Weight [g/m]</i>	Profil <i>Profile</i>	Teil-Nr. <i>Part #</i>
schwarz <i>Black</i>	5	26.0	I	092045
natur <i>Natural</i>	5	26.0	I	092047

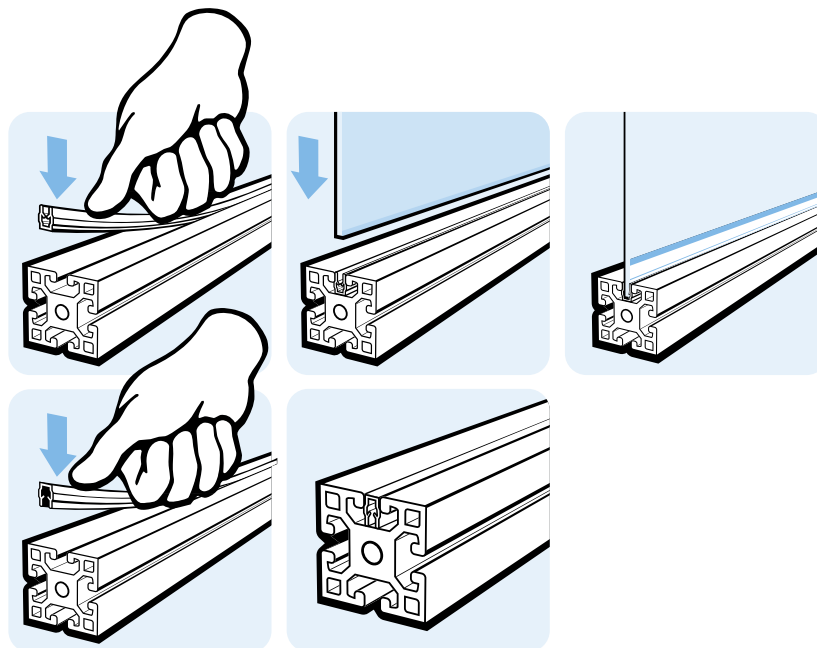

Abdeckelemente *Cover Elements*

Abdeckprofile *Cover Profile*

Nut 6 *Slot 6*



ABDECK- UND EINFASSPROFIL

COVER AND REDUCTION PROFILE

Ausführung	Kunststoff PP, Nut 6	Model	Plastic PP, slot 6
Beschreibung	zum Abdecken von Nuten mit Breite 6 mm und zum Einfassen von Flächenelementen mit 1 - 4 mm	Description	To cover size 6 profile slots and to secure panels with a thickness of 1 - 4 mm
Material	Kunststoff PP	Material	Plastic PP
Farbe	schwarz	Color	Black
Liefereinheit	200 Meter (100 Stück à 2 m)	Pack Quantity	200 meters (100 pieces at 2 m)
Extras	weitere Farben auf Anfrage	Specials	Other colors on request
Hinweis	Bitte beachten: Sie bestellen in Meter!	Tip	Please note: You are ordering in meters!

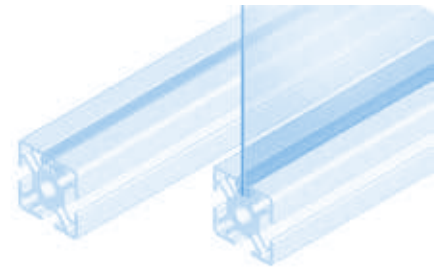
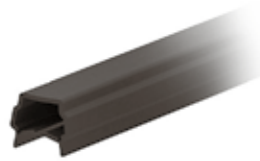
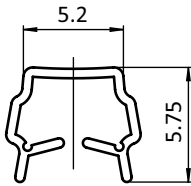

Abdeckprofil <i>Cover Profile</i>	Nut <i>Slot</i>	Gewicht [g/m] <i>Weight [g/m]</i>	Profil <i>Profile</i>	Teil-Nr. <i>Part #</i>
	6	17.0	B	092246

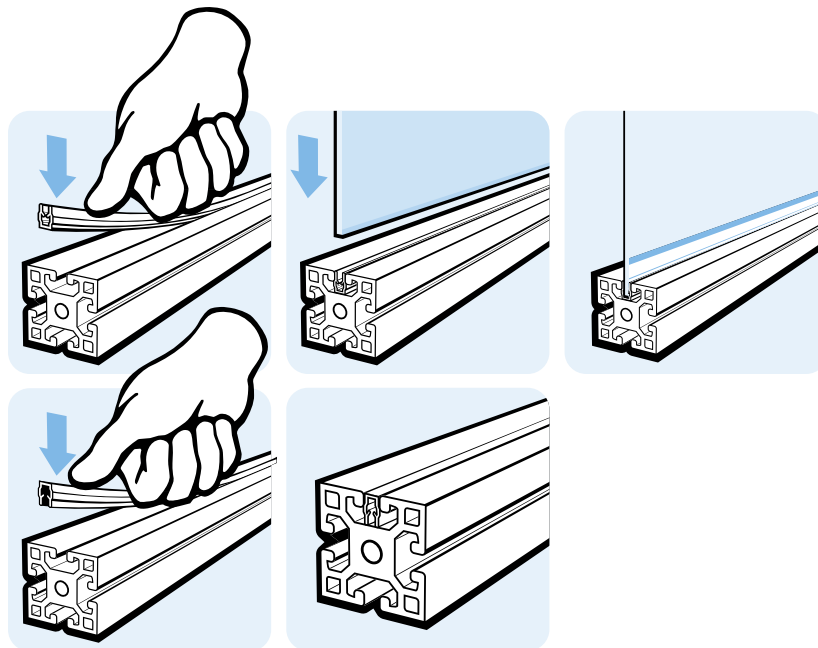

Abdeckelemente *Cover Elements*

Abdeckprofile *Cover Profile*

Nut 6 *Slot 6*



ABDECK- UND EINFASSPROFIL

COVER AND REDUCTION PROFILE

Ausführung	Kunststoff PP, Nut 6	Model	Plastic PP, slot 6
Beschreibung	zum Abdecken von Nuten mit Breite 6 mm und zum Einfassen von Flächenelementen mit 2 - 3,5 mm	Description	To cover size 6 profile slots and to secure panels with a thickness of 2 - 3.5 mm
Material	Kunststoff PP	Material	Plastic PP
Farbe	schwarz / natur / grau	Color	Black / natural / gray
Liefereinheit	200 Meter (100 Stück à 2 m)	Pack Quantity	200 meters (100 pieces at 2 m)
Extras	weitere Farben auf Anfrage	Specials	Other colors on request
Hinweis	Bitte beachten: Sie bestellen in Meter!	Tip	Please note: You are ordering in meters!

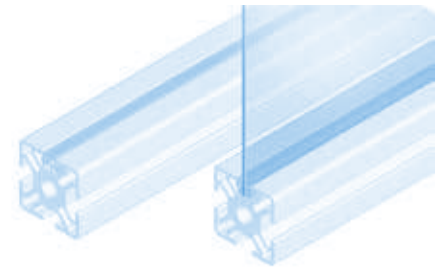
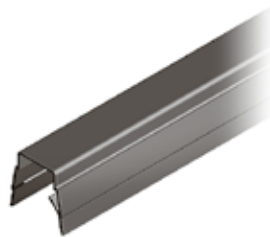
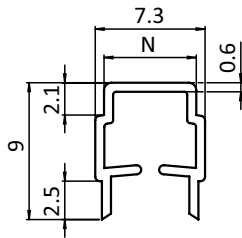

Abdeck- und Einfassprofil <i>Cover and Reduction Profile</i>	Nut Slot	Gewicht [g/m] Weight [g/m]	Profil Profile	Teil-Nr. Part #
schwarz <i>Black</i>	6	26.0	I	092033
natur <i>Natural</i>	6	26.0	I	092034
grau ≈ RAL 7035 <i>Gray</i>	6	26.0	I	092033S01

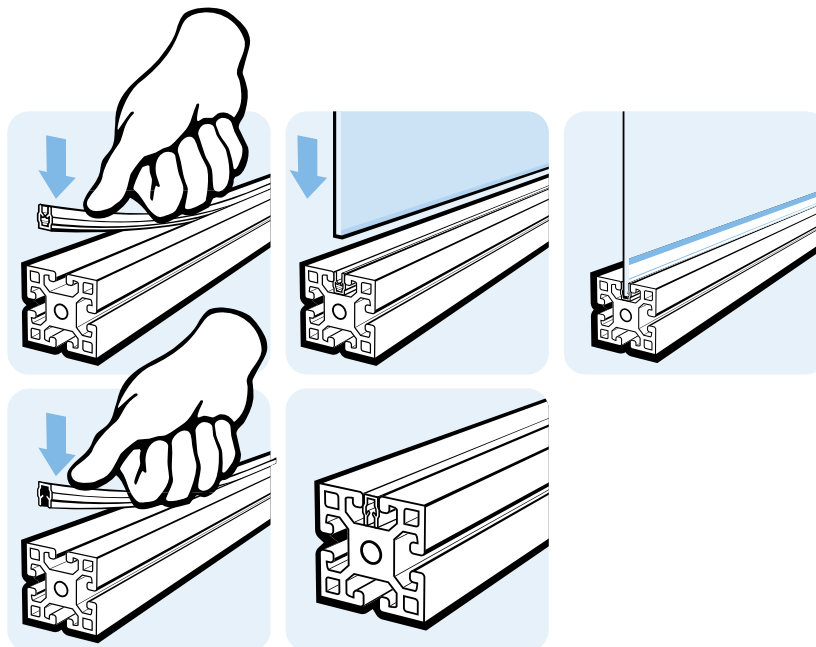

Abdeckelemente *Cover Elements*

Abdeckprofile *Cover Profile*

Nut 6 *Slot 6*



ABDECKPROFIL

COVER PROFILE

Ausführung	Kunststoff PP, Nut 6	Model	Plastic PP, slot 6
Beschreibung	zum Abdecken von Nuten mit Breite 6 mm und Steghöhe 3,0 mm	Description	To cover T-Slots with 6 mm width and a 3.0 mm profile web
Material	Kunststoff PP	Material	Plastic PP
Farbe	schwarz, natur, alufarbig	Color	Black, natural, alu color
Liefereinheit	200 Meter (100 Stück à 2 m)	Pack Quantity	200 meters (100 pieces at 2 m)
Extras	weitere Farben auf Anfrage	Specials	Other colors on request
Hinweis	Bitte beachten: Sie bestellen in Meter!	Tip	Please note: You are ordering in meters!

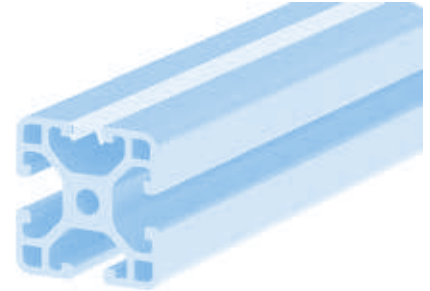
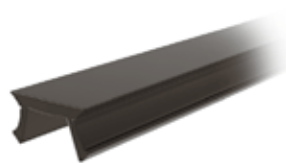
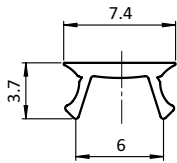

Abdeckprofil <i>Cover Profile</i>	Nut 6 <i>Slot 6</i>	Gewicht [g/m] <i>Weight [g/m]</i>	Profil <i>Profile</i>	Teil-Nr. <i>Part #</i>
schwarz <i>Black</i>	6	11.0	I	092130
natur <i>Natural</i>	6	11.0	I	092130S01
alufarbig geprägt <i>Alu color coated</i>	6	11.0	I	092130A

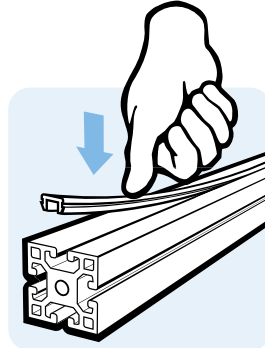

Abdeckelemente *Cover Elements*

Abdeckprofile *Cover Profile*

Nut 8 *Slot 8*



ABDECK- UND EINFASSPROFIL

COVER AND REDUCTION PROFILE

Ausführung	Kunststoff PP, Nut 8	Model	Plastic PP, slot 8
Beschreibung	zum Abdecken von Nuten mit Breite 8 mm und zum Einfassen von Flächenelementen mit 4 - 6 mm	Description	To cover size 8 profile slots and to secure panels with a thickness of 4 - 6 mm
Material	Kunststoff PP	Material	Plastic PP
Farbe	schwarz, natur, grau, rot, blau, gelb, weißaluminium	Color	Black, natural, gray, red, blue, yellow, white aluminum
Liefereinheit	200 Meter (100 Stück à 2 m)	Pack Quantity	200 meters (100 pieces at 2 m)
Extras	weitere Farben auf Anfrage	Specials	Other colors on request
Hinweis	Bitte beachten: Sie bestellen in Meter!	Tip	Please note: You are ordering in meters!

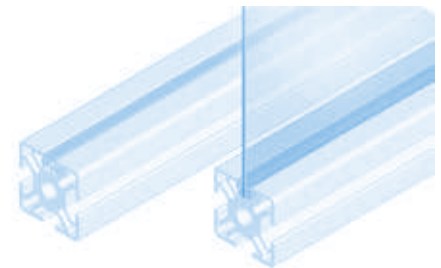
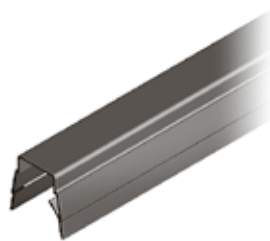
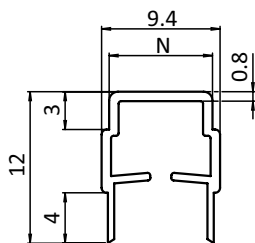

Abdeck- und Einfassprofil <i>Cover and Reduction Profile</i>	Nut <i>Slot</i>	Gewicht [g/m] <i>Weight [g/m]</i>	Profil <i>Profile</i>	Teil-Nr. <i>Part #</i>
schwarz <i>Black</i>	8	26.0	I	092031
natur <i>Natural</i>	8	26.0	I	092030
grau ≈ RAL 7035 <i>Gray</i>	8	26.0	I	092035
rot ≈ RAL 3020 <i>Red</i>	8	26.0	I	092036
blau ≈ RAL 5005 <i>Blue</i>	8	26.0	I	092037
gelb ≈ RAL 1018 <i>Yellow</i>	8	26.0	I	092031S03
weißaluminium ≈ RAL 9006 <i>White aluminum</i>	8	26.0	I	092031S04

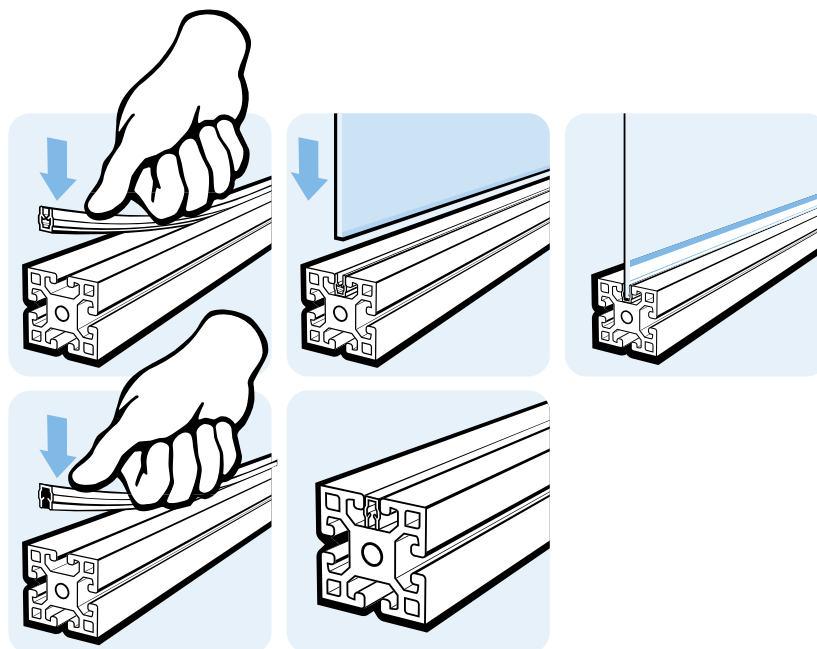

Abdeckelemente *Cover Elements*

Abdeckprofile *Cover Profile*

Nut 8 *Slot 8*



ABDECK- UND EINFASSPROFIL

COVER AND REDUCTION PROFILE

Ausführung	Kunststoff PP + TPE, Nut 8	Model	Plastic PP + TPE, slot 8
Beschreibung	zum Abdecken von Nuten mit Breite 8 mm und zum Einfassen von Flächenelementen mit 4 - 6 mm	Description	To cover size 8 profile slots and to secure panels with a thickness of 4 - 6 mm
Material	Kunststoff PP + TPE	Material	Plastic PP + TPE
Farbe	schwarz	Color	Black
Liefereinheit	200 Meter (100 Stück à 2 m)	Pack Quantity	200 meters (100 pieces at 2 m)
Extras	weitere Farben auf Anfrage	Specials	Other colors on request
Hinweis	Bitte beachten: Sie bestellen in Meter!	Tip	Please note: You are ordering in meters!

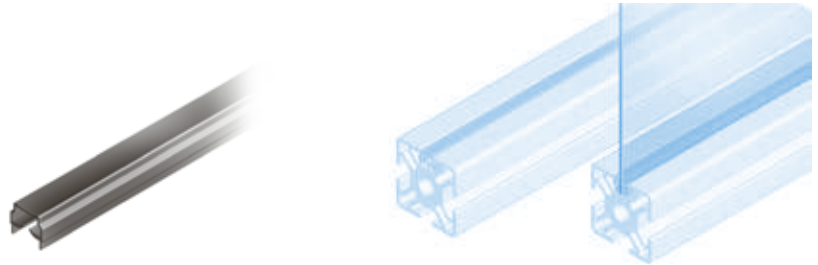
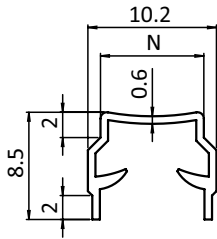

Abdeck- und Einfassprofil <i>Cover and Reduction Profile</i>	Nut <i>Slot</i>	Gewicht [g/m] <i>Weight [g/m]</i>	Profil <i>Profile</i>	Teil-Nr. <i>Part #</i>
	8	25.0	B	092242

Abdeckelemente *Cover Elements*

Abdeckprofile *Cover Profile*

Nut 8 Slot 8



ABDECKPROFIL

COVER PROFILE

Ausführung	Kunststoff PP, Nut 8, 10	Model	Plastic PP, slot 8, 10
Beschreibung	zum Abdecken von Nuten mit Breite 8 und 10 mm	Description	To cover size 8 and 10 profile slots
Material	Kunststoff PP	Material	Plastic PP
Farbe	schwarz, gelb, orange, rot, blau, grau, weiß, natur, alufarbig	Color	Black, yellow, orange, red, blue, gray, white, nature, alu color
Liefereinheit	200 Meter (100 St. à 2m)	Pack Quantity	200 meters (100 pieces at 2m)
Extras	weitere Farben auf Anfrage	Specials	Other colors on request
Hinweis	Bitte beachten: Sie bestellen in Meter!	Tip	Please note: You are ordering in meters!

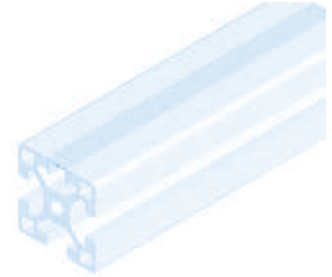
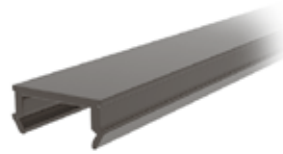
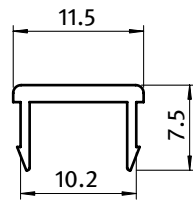
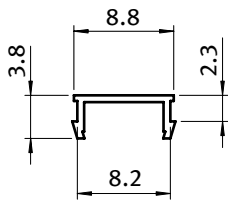

Abdeckprofil Cover Profile	Nut Slot	Gewicht [g/m] Weight [g/m]	Profil Profile	Teil-Nr. Part #
schwarz <i>Black</i>	8	10.0	B	092050
schwarz, ⚡ elektrostatisch entladend <i>Black, ⚡ electrostatically discharging</i>	8	10.0	B	092050S12
gelb ≈ RAL 1018 <i>Yellow</i>	8	10.0	B	092054
rot ≈ RAL 3020 <i>Red</i>	8	10.0	B	092050S07
blau ≈ RAL 5005 <i>Blue</i>	8	10.0	B	092050S04
grau ≈ RAL 7035 <i>Gray</i>	8	10.0	B	092052
natur <i>Natural</i>	8	10.0	B	092050S03
alufarbig geprägt <i>Alu color imprint</i>	8	10.0	B	092050A
alufarbig geprägt, ⚡ elektrostatisch entladend <i>Alu color imprint, ⚡ electrostatically discharging</i>	8	10.0	B	092050AS01
schwarz <i>Black</i>	10	28.1	B	092041
schwarz, ⚡ elektrostatisch entladend <i>Black, ⚡ electrostatically discharging</i>	10	28.1	B	092041S08
gelb ≈ RAL 1018 <i>Yellow</i>	10	28.1	B	092044
gelb ≈ RAL 1023 <i>Yellow</i>	10	28.1	B	092044S01
orange ≈ RAL 2004 <i>Orange</i>	10	28.1	B	092043
rot ≈ RAL 3020 <i>Red</i>	10	28.1	B	092041S03
blau ≈ RAL 5005 <i>Blue</i>	10	28.1	B	092041S06
grau ≈ RAL 7035 <i>Gray</i>	10	28.1	B	092042
weiß ≈ RAL 9003 <i>White</i>	10	28.1	B	092041S05
natur <i>Natural</i>	10	28.1	B	092041S13
alufarbig geprägt <i>Alu color imprint</i>	10	28.1	B	092041A
alufarbig geprägt, ⚡ elektrostatisch entladend <i>Alu color imprint, ⚡ electrostatically discharging</i>	10	28.1	B	092041AS01

Abdeckelemente *Cover Elements*

Abdeckprofile *Cover Profile*

Nut 8 *Slot 8*



ABDECKPROFIL

COVER PROFILE

Ausführung	Kunststoff PP, Nut 8	Model	Plastic PP, slot 8
Beschreibung	zum Abdecken von Nuten mit Breite 8 mm und Steghöhe 4,5 mm	Description	To cover T-Slots with 8 mm width and a 4.5 mm profile web
Material	Kunststoff PP	Material	Plastic PP
Farbe	schwarz, gelb, grau, natur, alufarbig	Color	Black, yellow, gray, natural, alu color
Liefereinheit	200 Meter (100 Stück à 2m)	Pack Quantity	200 meters (100 pieces at 2m)
Extras	weitere Farben auf Anfrage	Specials	Other colors on request
Hinweis	Bitte beachten: Sie bestellen in Meter!	Tip	Please note: You are ordering in meters!

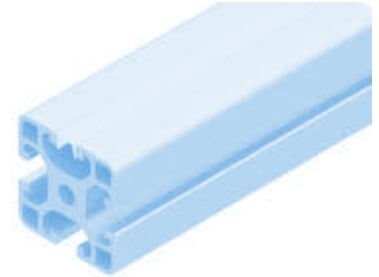
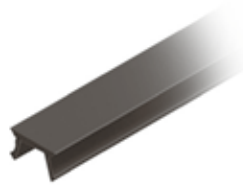
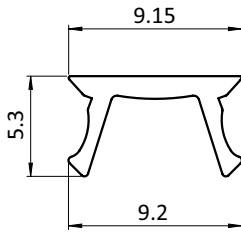

Abdeckprofil <i>Cover Profile</i>	Nut <i>Slot</i>	Gewicht [g/m] <i>Weight [g/m]</i>	Profil <i>Profile</i>	Teil-Nr. <i>Part #</i>
schwarz <i>Black</i>	8	16.0	I	092080
gelb ≈ RAL 1018 <i>Yellow</i>	8	16.0	I	092081
grau ≈ RAL 7035 <i>Gray</i>	8	16.0	I	092085
natur <i>Natural</i>	8	16.0	I	092082
alufarbig geprägt <i>Alu color imprint</i>	8	16.0	I	092080A

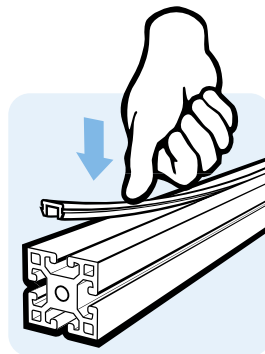

Abdeckelemente *Cover Elements*

Abdeckprofile *Cover Profile*

Nut 8 *Slot 8*



ABDECKPROFIL

COVER PROFILE

Ausführung	Aluminium, Nut 8	Model	Aluminum, slot 8
Beschreibung	zum Abdecken von Nuten mit Breite 8 mm und Steghöhe 4,5 mm	Description	To cover T-Slots with 8 mm width and a 4.5 mm profile web
Material	Aluminium, eloxiert	Material	Aluminum, anodized
Liefereinheit	50 Meter (25 St. à 2m)	Pack Quantity	50 meters (25 pieces at 2m)
Hinweis	Bitte beachten: Sie bestellen in Meter!	Tip	Please note: You are ordering in meters!

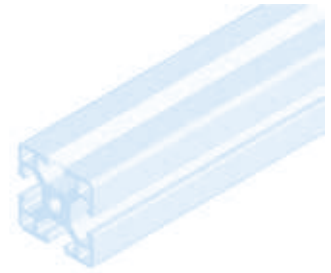
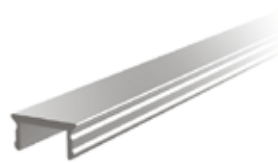
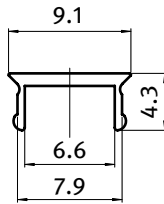

Abdeckprofil <i>Cover Profile</i>	Nut <i>Slot</i>	Gewicht [g/m] <i>Weight [g/m]</i>	Profil <i>Profile</i>	Teil-Nr. <i>Part #</i>
	8	33.0	I	092055

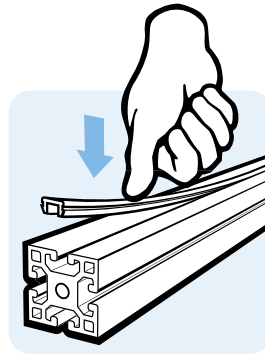

Abdeckelemente *Cover Elements*

Abdeckprofile *Cover Profile*

Nut 8 *Slot 8*



ABDECKPROFIL

COVER PROFILE

Ausführung	Aluminium, Nut 8	Model	Aluminum, slot 8
Beschreibung	zum Abdecken von Nuten mit Breite 8 mm und Steghöhe 4,5 mm	Description	To cover T-Slots with 8 mm width and a 4.5 mm profile web
Material	Aluminium, eloxiert	Material	Aluminum, anodized
Liefereinheit	50 Meter (25 St. à 2m)	Pack Quantity	50 meters (25 pieces at 2m)
Hinweis	Bitte beachten: Sie bestellen in Meter!	Tip	Please note: You are ordering in meters!

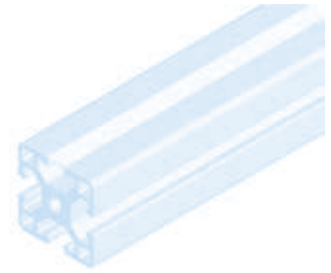
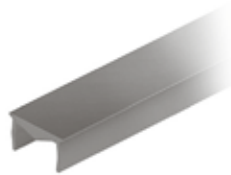
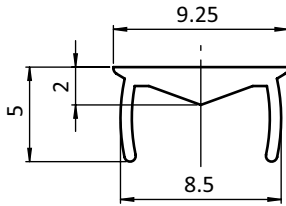

Abdeckprofil <i>Cover Profile</i>	Nut <i>Slot</i>	Gewicht [g/m] <i>Weight [g/m]</i>	Profil <i>Profile</i>	Teil-Nr. <i>Part #</i>
	8	43.0	B	092071

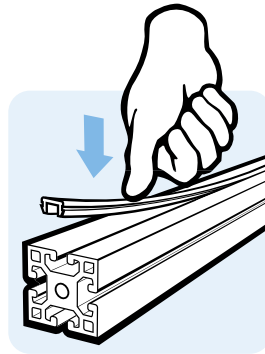

Abdeckelemente *Cover Elements*

Abdeckprofile *Cover Profile*

Nut 10 *Slot 10*



ABDECKPROFIL

COVER PROFILE

Ausführung	Aluminium, Nut 10	Model	Aluminum, slot 10
Beschreibung	zum Abdecken von Nuten mit Breite 10 mm und Steghöhe 6 mm	Description	To cover T-Slots with 10 mm width and a 6 mm profile web
Material	Aluminium, eloxiert	Material	Aluminum, anodized
Liefereinheit	50 Meter (25 St. à 2m)	Pack Quantity	50 meters (25 pieces at 2m)
Hinweis	Bitte beachten: Sie bestellen in Meter!	Tip	Please note: You are ordering in meters!

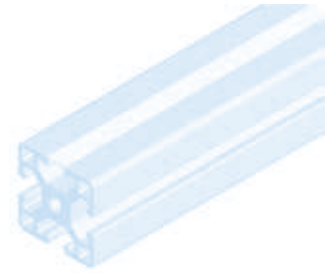
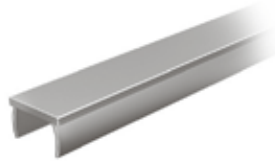
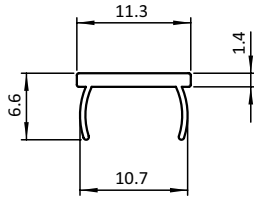

Abdeckprofil <i>Cover Profile</i>	Nut <i>Slot</i>	Gewicht [g/m] <i>Weight [g/m]</i>	Profil <i>Profile</i>	Teil-Nr. <i>Part #</i>
	10	56.5	B	092070

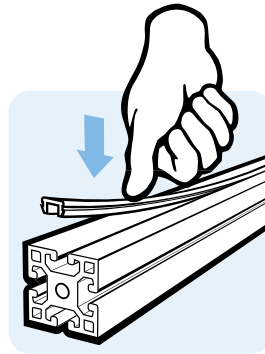



ABDECKPROFIL

COVER PROFILE

Ausführung	Kunststoff NBR, Nut 6, Nut 8	Model	Plastic NBR, slot 6, slot 8
Beschreibung	zum Abdecken von Aluprofilen	Description	To cover aluminum profiles
Material	Kunststoff NBR, ≈80 Shore A	Material	Plastic NBR, ≈80 Shore A
Farbe	schwarz	Color	Black
Liefereinheit	20 Meter (Spule)	Pack Quantity	20 meter (spool)
Hinweis	Bitte beachten: Sie bestellen in Meter!	Tip	Please note: You are ordering in meters!

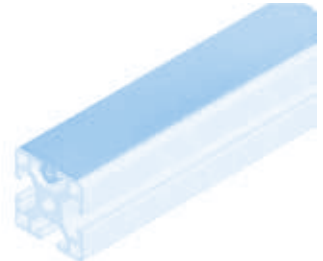
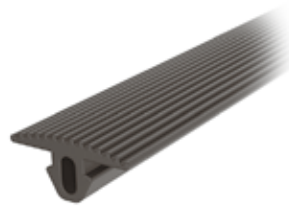
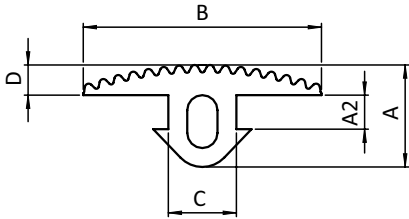

Abdeckprofil Cover Profile	A [mm]	A2 (Profil) [mm] A2 (Profile) [mm]	B [mm]	C [mm]	D [mm]	Nut Slot	Gewicht [g/m] Weight [g/m]	Profil Profile	Teil-Nr. Part #
	11.0	2.5 (3.0)	26.0	6.5	3.0	6	103.0	I	092058
	13.5	4.5 (4.5)	31.5	9	4.0	8	210.0	I	092057

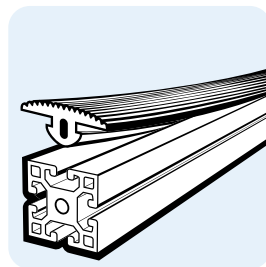

Abdeckelemente *Cover Elements*

Abdeckkappen *Cover Caps*

Rastermaß 20 mm *Modular Dimension 20 mm*



ABDECKKAPPE FÜR RASTERMAß 20 MM

COVER CAP FOR 20 MM MODULAR DIMENSION

Ausführung	Rastermaß 20 mm	Model	20 mm modular dimension
Beschreibung	zum Abdecken der Profilenden	Description	To cover the end of the profile
Material	Kunststoff PA, glasfaserverstärkt	Material	Plastic PA, glass fiber reinforced
Farbe	schwarz	Color	Black
Liefereinheit	100 Stück	Pack Quantity	100 pieces
Extras	☁ elektrostatisch entladend, weitere Größen, weitere Farben auf Anfrage	Specials	☁ electrostatically discharging, other sizes, other colors on request

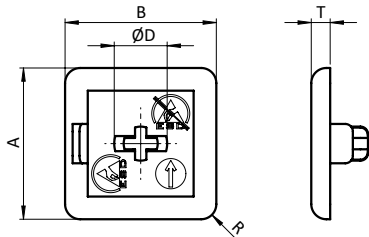

Abdeckkappe Cover Cap	ØD [mm]	R [mm]	T [mm]	Eigenschaft Description	Maße A x B [mm] Dimensions A x B [mm]	Profil Profile	Teil-Nr. Part #
Nut 5 <i>Slot 5</i>	3.4 (3.3)	2.0	3.0	2 Kreuze <i>2 cross</i>	10 x 20	I	091125
	3.4 (3.3)	2.0	2.5	2 Stifte <i>2 pins</i>	10 x 40	I	091236
	4.5 (4.3)	2.5	4.0	1 Kreuz <i>1 cross</i>	20 x 20	I	091043
	4.5 (4.3)	2.0	2.5	neue Ausführung, 1 Stift <i>New version, 1 pin</i>	20 x 20	I	091180
	4.5 (4.3)	2.5	4.0	1 Kreuz <i>1 cross</i>	20 x 40	I	091050
	4.5 (4.3)	2.0	2.5	neue Ausführung, 2 Kreuze <i>New version, 2 cross</i>	20 x 40	I	091181
	4.5 (4.3)	2.0	2.5	3 Kreuze <i>3 cross</i>	20 x 60	I	091183
	4.5 (4.3)	2.0	2.5	4 Kreuze <i>4 cross</i>	40 x 40	I	091182
Nut 6 <i>Slot 6</i>	5.4 (5.5)	2.5	4.0	1 Kreuz <i>1 cross</i>	20 x 20	B	091042
	5.7 (5.5)	1.5	2.5	neue Ausführung, 1 Kreuz <i>New version, 1 cross</i>	20 x 20	B	091332



ABDECKKAPPE FÜR RASTERMAß 30 MM

COVER CAP FOR 30 MM MODULAR DIMENSION

Ausführung	Rastermaß 30 mm	Model	30 mm modular dimension
Beschreibung	zum Abdecken der Profilenenden	Description	To cover the end of the profile
Material	Kunststoff PA, glasfaserverstärkt	Material	Plastic PA, glass fiber reinforced
Farbe	schwarz	Color	Black
Liefereinheit	100 Stück	Pack Quantity	100 pieces
Extras	☁ elektrostatisch entladend, weitere Größen, weitere Farben auf Anfrage	Specials	☁ electrostatically discharging, other sizes, other colors on request

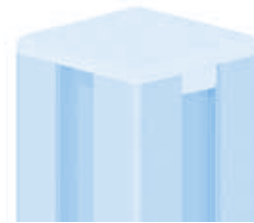
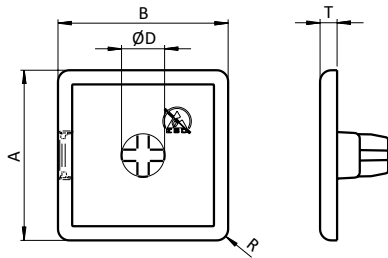

Abdeckkappe <i>Cover Cap</i>	ØD [mm]	R [mm]	T [mm]	Eigenschaft <i>Description</i>	Maße A x B [mm] <i>Dimensions A x B [mm]</i>	Profil <i>Profile</i>	Teil-Nr. <i>Part #</i>
Nut 6 <i>Slot 6</i>	5.2 (5.0)	3.0	3.0	4 Kreuze 4 cross	30 x 120	I	091187
	5.2 (5.0)	3.0	3.0	1 Kreuz 1 cross	30 x 30	I	091184
	5.2 (5.0)	3.0	3.0	1 Kreuz 1 cross	30 x 30 45°	I	091188
	5.2 (5.0)	3.0	3.0	1 Kreuz 1 cross	30 x 30 R30 - 90°	I	091245
	6.9 (7.3)	3.0	4.0	2 Kreuze 2 cross	30 x 60	I	091141
	5.2 (5.0)	3.0	3.0	neue Ausführung, 2 Kreuze <i>New version, 2 cross</i>	30 x 60	I	091185
	5.2 (5.0)	3.0	3.0	4 Kreuze 4 cross	60 x 60	I	091186
Nut 8 <i>Slot 8</i>	3.3	2.0	3.0	3 Stifte 3 pins	11 x 20	B	091346
	7.6 (7.3)	3.0	4.0	1 Kreuz 1 cross	30 x 30	B	091027
	10.8 (10.0)	3.0	4.0	neue Ausführung 1, 1 Kreuz gedreht 45° <i>New version 1, 1 cross turned 45°</i>	30 x 30	B	091252
	7.6 (7.3)	2.0	3.0	neue Ausführung 2, 1 Kreuz <i>New version 2, 1 cross</i>	30 x 30	B	091371
	4.0	2.0	3.0	mit Loch Ø 8.5 mm, 4 Stifte <i>With hole Ø 8.5 mm, 4 pins</i>	30 x 30	B	091359
	10.8 (10.0)	2.0	3.0	1 Kreuz 1 cross	30 x 30 R25 - 90°	B	091344
	7.6 (7.3)	3.0	4.0	2 Kreuze 2 cross	30 x 60	B	091179
Nut 8 / 10 <i>Slot 8 / 10</i>	8.4 (7.3)	2.0	3.0	4 Stifte 4 pins	30 x 45	B	091370
	8.4 (7.3)	2.0	3.0	☁ elektrostatisch entladend, 4 Stifte ☁ electrostatically discharging, 4 pins	30 x 45	B	091370S01

Abdeckelemente *Cover Elements*

Abdeckkappen *Cover Caps*

Rastermaß 40 mm *Modular Dimension 40 mm*



ABDECKKAPPE FÜR RASTERMAß 40 MM

COVER CAP FOR 40 MM MODULAR DIMENSION

Ausführung	Rastermaß 40 mm	Model	40 mm modular dimension
Beschreibung	zum Abdecken der Profilenden	Description	To cover the end of the profile
Material	Kunststoff PA, glasfaserverstärkt	Material	Plastic PA, glass fiber reinforced
Farbe	schwarz	Color	Black
Liefereinheit	100 Stück	Pack Quantity	100 pieces
Extras	☁ elektrostatisch entladend, weitere Größen, weitere Farben auf Anfrage	Specials	☁ electrostatically discharging, other sizes, other colors on request

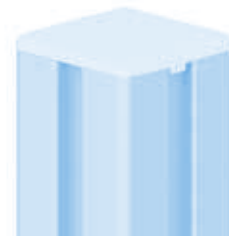
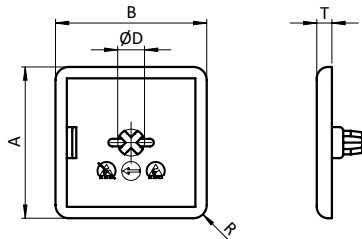

Abdeckkappe <i>Cover Cap</i>	ØD [mm]	R [mm]	T [mm]	Eigenschaft <i>Description</i>	Maße [mm] <i>Dimensions [mm]</i>	Profil <i>Profile</i>	Teil-Nr. <i>Part #</i>
Nut 8 <i>Slot 8</i>	5.1 (5.0)	3.5	4.0	2 Stifte <i>2 pins</i>	16 x 40	I	091077
	4.4 (4.3)	3.5	4.0	2 Stifte <i>2 pins</i>	16 x 80	I	091078
	4.3 (4.0)	3.5	4.0	6 Stifte <i>6 pins</i>	16 x 160	I	091278
	7.1 (6.8)	3.5	4.0	1 Kreuz <i>1 cross</i>	40 x 40	I	091007
	7.0 (6.8)	4.0	4.0	1 Kreuz <i>1 cross</i>	40 x 40 45°	I	091048
	7.2 (6.8)	2.5	4.0	1 Kreuz <i>1 cross</i>	40 x 40 R40 - 90°	I	091045
	6.8 (6.8)	4.0	4.0	neue Ausführung, 1 Kreuz <i>New version, 1 cross</i>	40 x 40 R40 - 90°	I	091320
	6.9 (6.8)	4.0	4.0	2 Kreuze <i>2 cross</i>	40 x 80	I	091009
	6.9 (6.8)	3.0	4.0	1 Kreuz und 2 Stifte <i>1 cross and 2 pins</i>	40 x 120	I	091094
	6.9 (6.8)	3.5	4.0	2 Kreuze und 2 Stifte <i>2 cross and 2 pins</i>	40 x 160	I	091209
	6.8 (6.8)	4.0	4.0	4 Kreuze <i>4 cross</i>	80 x 80	I	091023
	6.9 (6.8)	3.5	4.0	4 Kreuze <i>4 cross</i>	80 x 120	I	091095
	6.8 (6.8)	4.0	4.0	8 Stifte <i>8 pins</i>	80 x 160	I	091118
Nut 10 <i>Slot 10</i>	10.2 (10.0)	3.0	4.0	1 Kreuz <i>1 cross</i>	40 x 40	B	091046
	10.4 (10.0)	3.0	4.0	☁ elektrostatisch entladend, 1 Kernloch-Zapfen ☁ electrostatically discharging, 1 Pin for core hole	40 x 40 R30 - 90°	B	091345S01
	10.1 (10.0)	3.0	4.0	2 Kreuze <i>2 cross</i>	40 x 80	B	091137
	10.4 (10.0)	3.0	4.0	4 Kreuze <i>4 cross</i>	80 x 80	B	091135



ABDECKKAPPE FÜR RASTERMAß 45 MM

COVER CAP FOR 45 MM MODULAR DIMENSION

Ausführung	Rastermaß 45 mm	Model	45 mm modular dimension
Beschreibung	zum Abdecken der Profilenenden	Description	To cover the end of the profile
Material	Kunststoff PA, glasfaserverstärkt	Material	Plastic PA, glass fiber reinforced
Farbe	schwarz	Color	Black
Liefereinheit	100 Stück	Pack Quantity	100 pieces
Extras	☁ elektrostatisch entladend, weitere Größen, weitere Farben auf Anfrage	Specials	☁ electrostatically discharging, other sizes, other colors on request

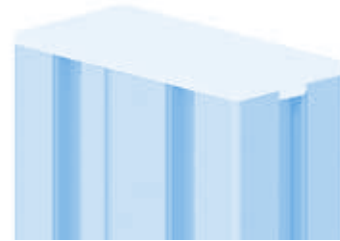
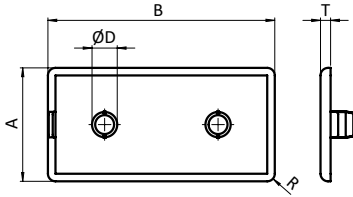

Abdeckkappe <i>Cover Cap</i>	ØD [mm]	R [mm]	T [mm]	Eigenschaft <i>Description</i>	Maße [mm] <i>Dimensions [mm]</i>	Profil <i>Profile</i>	Teil-Nr. <i>Part #</i>
Nut 10 <i>Slot 10</i>	4.0	3.0	4.0	4 Stifte 4 pins	22.5 x 45	B	091002
	10.4 (10.0)	4.0	4.0	1 Kernloch-Zapfen 1 Pin for core hole	45 x 45	B	091011
	4.0	3.0	4.0	mit Loch Ø 17.0 mm, 4 Stifte 4.3 <i>With hole Ø 17.0 mm, 4 pins 4.3</i>	45 x 45	B	091015
	10.8 (10.0)	3.0	4.0	1 Kernloch-Zapfen 1 Pin for core hole	45 x 60	B	091017
	(4.0)	3.0	4.0	mit Loch Ø 18.3 mm, 4 Stifte 4.3 <i>With hole Ø 18.3 mm, 4 pins 4.3</i>	45 x 60	B	091083
	10.4 (10.0)	3.0	4.0	2 Kernloch-Zapfen 2 Pins for core hole	45 x 90	B	091006
	-	3.5	4.0	4 Stützrippen 4 support ribs	90 x 90	B	091024
	15.1	3.0	4.0	neue Ausführung, 4 Stützrippen <i>New version, 4 support ribs</i>	90 x 90	B	091207
	10.2 (10.0)	5.0	4.0	4 Kernloch-Zapfen, 4 Stifte <i>4 Pins for core hole, 4 pins</i>	90 x 90 leicht (superleicht) <i>90 x 90 light (superlight)</i>	B	091030
	15.2	3.0	4.0	8 Stützrippen 8 support ribs	90 x 90 leicht (superleicht) <i>90 x 90 light (superlight)</i>	B	091276

Abdeckelemente *Cover Elements*

Abdeckkappen *Cover Caps*

Rastermaß 50 mm *Modular Dimension 50 mm*



ABDECKKAPPE FÜR KLEMMPROFIL

COVER CAP FOR CLAMP PROFILE

Ausführung	Rastermaß 50 mm	Model	50 mm modular dimension
Beschreibung	zum Abdecken der Profilenden	Description	To cover the end of the profile
Material	Kunststoff PA, glasfaserverstärkt	Material	Plastic PA, glass fiber reinforced
Farbe	schwarz	Color	Black
Liefereinheit	100 Stück	Pack Quantity	100 pieces
Extras	☁ elektrostatisch entladend, weitere Größen, weitere Farben auf Anfrage	Specials	☁ electrostatically discharging, other sizes, other colors on request

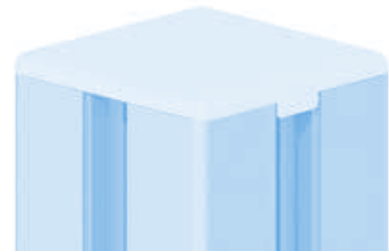
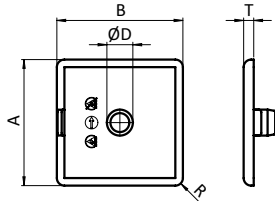

Abdeckkappe für Klemmprofil <i>Cover Cap for Clamp Profile</i>	ØD [mm]	R [mm]	T [mm]	Eigenschaft <i>Description</i>	Maße [mm] <i>Dimensions [mm]</i>	Profil <i>Profile</i>	Teil-Nr. <i>Part #</i>
Nut 10 <i>Slot 10</i>	10.3 (10.0)	3.0	4.0	1 Kernloch-Zapfen <i>1 Pin for core hole</i>	50 x 50	B	091028

Abdeckelemente *Cover Elements*

Abdeckkappen *Cover Caps*

Rastermaß 60 mm *Modular Dimension 60 mm*



ABDECKKAPPE FÜR RASTERMAß 60 MM

COVER CAP FOR 60 MM MODULAR DIMENSION

Ausführung	Rastermaß 60 mm	Model	60 mm modular dimension
Beschreibung	zum Abdecken der Profilenenden	Description	To cover the end of the profile
Material	Kunststoff PA, glasfaserverstärkt	Material	Plastic PA, glass fiber reinforced
Farbe	schwarz	Color	Black
Liefereinheit	100 Stück	Pack Quantity	100 pieces
Extras	☁ elektrostatisch entladend, weitere Größen, weitere Farben auf Anfrage	Specials	☁ electrostatically discharging, other sizes, other colors on request

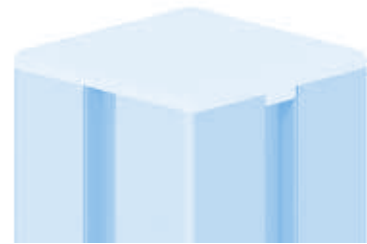
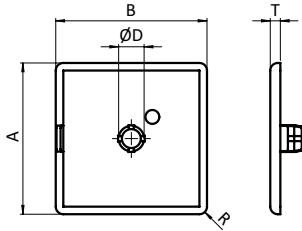

Abdeckkappe <i>Cover Cap</i>	ØD [mm]	R [mm]	T [mm]	Eigenschaft <i>Description</i>	Maße [mm] <i>Dimensions [mm]</i>	Profil <i>Profile</i>	Teil-Nr. <i>Part #</i>
Nut 10 <i>Slot 10</i>	10.6 (10.0)	3.0	4.0	1 Kernloch-Zapfen <i>1 Pin for core hole</i>	60 x 60	B	091021

Abdeckelemente *Cover Elements*

Abdeckkappen *Cover Caps*

Abdeckkappe für Klemmprofil *Cover Cap for Clamp Profile*



ABDECKKAPPE FÜR KLEMMPROFIL

COVER CAP FOR CLAMP PROFILE

Ausführung	für Klemmprofil	Model	For clamp profile
Beschreibung	zum Abdecken der Profilenenden	Description	To cover the end of the profile
Material	Kunststoff PA, glasfaserverstärkt	Material	Plastic PA, glass fiber reinforced
Farbe	schwarz	Color	Black
Liefereinheit	100 Stück	Pack Quantity	100 pieces
Extras	☁ elektrostatisch entladend, weitere Größen, weitere Farben auf Anfrage	Specials	☁ electrostatically discharging, other sizes, other colors on request

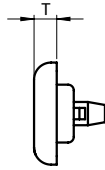
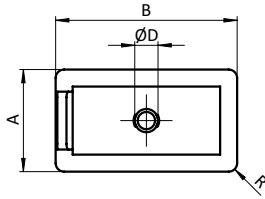

Abdeckkappe für Klemmprofil <i>Cover Cap for Clamp Profile</i>	ØD [mm]	R [mm]	T [mm]	Eigenschaft <i>Description</i>	Maße [mm] <i>Dimensions [mm]</i>	Profil <i>Profile</i>	Teil-Nr. <i>Part #</i>
Nut 10 <i>Slot 10</i>	4.3	1.5	4.0	1 Stift <i>1 pin</i>	18 x 32	I	091049

Abdeckelemente *Cover Elements*

Abdeckkappen *Cover Caps*

Abdeckkappe für Schutzgitterprofil *Cover Caps for Wire Mesh Frame Profiles*



ABDECKKAPPEN FÜR SCHUTZGITTERPROFILE

COVER CAPS FOR WIRE MESH FRAME PROFILES

Ausführung	Kunststoff PA	Model	Plastic PA
Beschreibung	zum Abdecken der Profilenenden von Schutzgitterprofilen	Description	To seal the end openings of conduit systems
Material	Kunststoff PA, glasfaserverstärkt	Material	Plastic PA, glass fiber reinforced
Farbe	schwarz	Color	Black
Liefereinheit	100 Stück	Pack Quantity	100 pieces
Extras	☁elektrostatisch entladend, weitere Größen, weitere Farben auf Anfrage	Specials	☁electrostatically discharging, other sizes, other colors on request

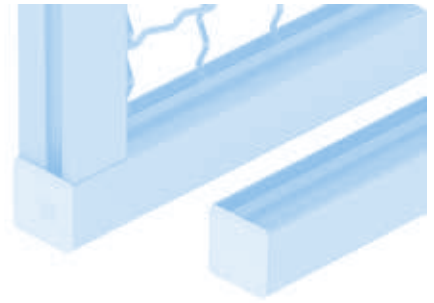
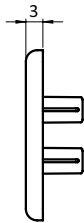
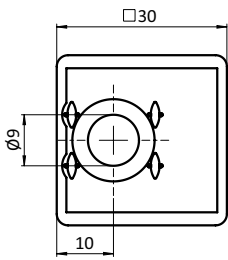

Abdeckkappen für Schutzgitterprofile <i>Cover Caps for Wire Mesh Frame Profiles</i>	ØD [mm]	R [mm]	T [mm]	Eigenschaft <i>Description</i>	Gewicht [g] <i>Weight [g]</i>	Profil <i>Profile</i>	Teil-Nr. <i>Part #</i>
mit Loch <i>With hole</i>		2.0	3.0	4 Stifte <i>4 pins</i>	3.4	B	091337
ohne Loch <i>Without hole</i>		2.0	3.0	4 Stifte <i>4 pins</i>	3.0	B	091337S01

ABDECKKAPPEN ANSCHRAUBBAR

COVER CAPS, SCREW-ON TYPE

Ausführung	Kunststoff PA	Model	Plastic PA
Beschreibung	anschraubbare Abdeckung für Profilen	Description	Bolt-on cover cap for the end of the aluminum profile
Material	Kunststoff PA, glasfaserverstärkt	Material	Plastic PA, glass fiber reinforced
Farbe	schwarz	Color	Black
Befestigung	* mit Senkkopfschrauben M4 x 16, Stahl verzinkt	Fastening	* With flat socket cap screws M4 x 16, zinc plated steel
Liefereinheiten	10 / 50 / 100 Stück	Pack Quantities	10 / 50 / 100 pieces
Extras	☁ elektrostatisch entladend, weitere Größen, weitere Farben auf Anfrage	Specials	☁ electrostatically discharging, other sizes, other colors on request
Hinweis	* Bitte separat bestellen: Senkkopfschrauben sind nicht im Lieferumfang der Abdeckkappen enthalten.	Tip	* Please order separately; flat socket cap screws are not included in delivery of the cover caps.

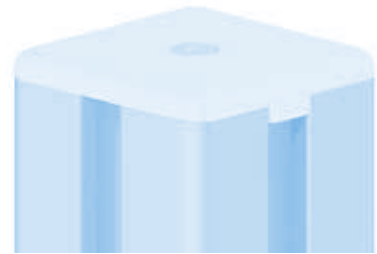
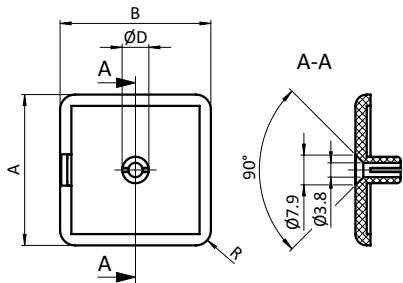

Abdeckkappe Cover Cap	D [mm]	R [mm]	T [mm]	Eigenschaft Description	Liefereinheit Pack Quantity	Gewicht [g] Weight [g]	Schraube Screw	Teil-Nr. Part #
30 x 30	7.0	3.0	4.0	1 Kernloch-Zapfen 1Pin for core hole	100	3.5	1 Schraube 1 screw	091065
30 x 60	7.0	3.0	4.0	2 Kernloch-Zapfen 2 Pins for core hole	100	7.6	2 Schrauben 2 screws	091066
40 x 40	7.0	4.0	4.0	1 Kernloch-Zapfen 1Pin for core hole	100	6.8	1 Schraube 1 screw	091067
40 x 80	7.0	4.0	4.0	2 Kernloch-Zapfen 2 Pins for core hole	50	13.0	2 Schrauben 2 screws	091068
45 x 45	10.5	3.0	4.0	1 Kernloch-Zapfen 1Pin for core hole	100	8.8	1 Schraube 1 screw	091070
45 x 60	10.4	3.0	4.0	1 Kernloch-Zapfen 1Pin for core hole	100	10.3	1 Schraube 1 screw	091072
45 x 90	10.4	3.0	4.0	2 Kernloch-Zapfen 2 Pins for core hole	10	15.0	2 Schrauben 2 screws	091073
60 x 60	10.5	3.0	4.0	1 Kernloch-Zapfen 1Pin for core hole	50	15.0	1 Schraube 1 screw	091071
80 x 80	7.0	4.0	4.0	4 Kernloch-Zapfen 4 Pins for core hole	10	27.4	4 Schrauben 4 screws	091069
90 x 90	10.4	3.0	4.0	4 Kernloch-Zapfen 4 Pins for core hole	10	34.4	4 Schrauben 4 screws	091074
Senkkopfschraube Flat socket cap screw				M4 x 16	100	1.0	*4DIN7991M0416M	



ABDECKKAPPEN ZN ANSCHRAUBBAR

COVER CAPS ZN SCREW-ON TYPE

Ausführung	Zinkdruckguss	Model	Zinc die-cast
Beschreibung	anschraubbare Abdeckung für Profilen	Description	Bolt-on cover cap for the end of the aluminum profiles
Material	Zinkdruckguss	Material	Zinc die-cast
Farbe	schwarz	Color	Black
Befestigung	mit selbstformenden Senkkopfschrauben S7 x 16*	Fastening	With self forming countersunk screws S7 x 16*
Liefereinheit	10 Stück	Pack Quantity	10 pieces
Extras	weitere Größen, weitere Farben auf Anfrage	Specials	Other sizes, other colors on request
Hinweis	* passende selbstformende Senkkopfschraube S7 x 16 siehe Seite 417	Tip	* Compatible self forming countersunk screw see page 417

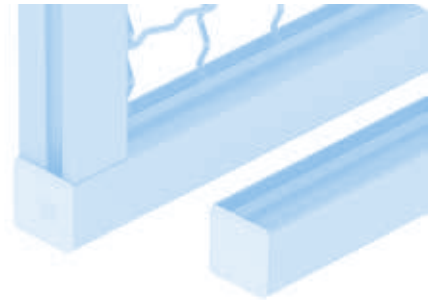
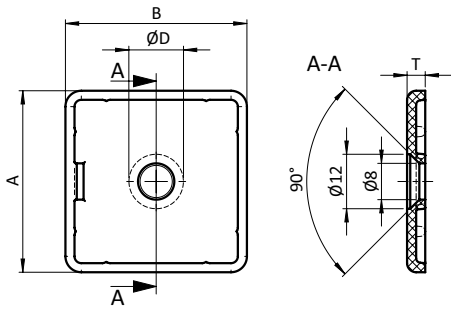

Abdeckkappe Cover Cap	ØD [mm]	R [mm]	T [mm]	Eigenschaft Description	Maße Dimensions	Gewicht [g] Weight [g]	Profil Profile	Teil-Nr. Part #
Nut 8 Slot 8	8.0 (6.8)	3.5	4.0	Bohrung für Senkschraube Bore for countersunk screw	40 x 40	25.5	I	091347
	8.0 (6.8)	3.5	4.0	Bohrung für Senkschraube Bore for countersunk screw	40 x 80	50.0	I	091348
	8.0 (6.8)	3.5	4.0	Bohrung für Senkschraube Bore for countersunk screw	80 x 80	98.0	I	091349

KANAL-ABDECKKAPPEN

CONDUIT CAPS

Ausführung	Kunststoff PA	Model	Plastic PA
Beschreibung	zur stirnseitigen Abdeckung von Kanälen; Befestigung mit Schraube M 4	Description	To seal the end openings of conduit systems; Fastening with screw M 4
Material	Kunststoff PA, glasfaserverstärkt	Material	Plastic PA, glass fiber reinforced
Farbe	schwarz	Color	Black
Liefereinheiten	10 / 50 / 100 Stück	Pack Quantities	10 / 50 / 100 pieces
Extras	☁ elektrostatisch entladend, weitere Größen, weitere Farben auf Anfrage	Specials	☁ electrostatically discharging, other sizes, other colors on request

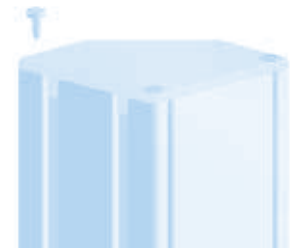
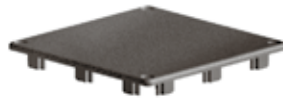
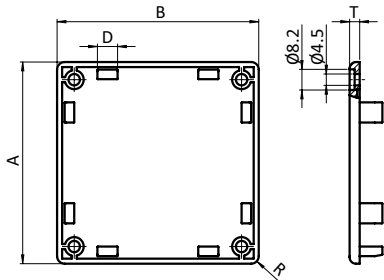

Abdeckkappe <i>Cover Cap</i>	R [mm]	T [mm]	Eigenschaft <i>Description</i>	Größe <i>Size</i>	Liefereinheit <i>Pack Quantity</i>	Gewicht [g] <i>Weight [g]</i>	Profil <i>Profile</i>	Teil-Nr. <i>Part #</i>
4 Bohrungen <i>4 bore holes</i>	4.0	4.0	4 Stützrippen <i>4 support ribs</i>	40 x 40	100	8.4	I	091168
	3.0	4.0	6 Stützrippen <i>6 support ribs</i>	40 x 80	50	14.0	I	091194
	3.0	4.0	8 Stützrippen <i>8 support ribs</i>	40 x 120	10	21.8	I	091201
	4.0	4.0	10 Stützrippen <i>10 support ribs</i>	40 x 160	10	29.0	I	091204
	3.0	4.0	8 Stützrippen <i>8 support ribs</i>	80 x 80	10	28.4	I	091195
45° links; 3 Bohrungen <i>45° left; 3 bore holes</i>	4.0	4.0	4 Stützrippen <i>4 support ribs</i>	80 x 80	10	27.0	I	091248L
45° rechts; 3 Bohrungen <i>45° right; 3 bore holes</i>	4.0	4.0	4 Stützrippen <i>4 support ribs</i>	80 x 80	10	27.0	I	091248R
4 Bohrungen <i>4 bore holes</i>	3.0	4.0	10 Stützrippen <i>10 support ribs</i>	80 x 120	10	46.6	I	091202
	3.0	4.0	12 Stützrippen <i>12 support ribs</i>	80 x 160	10	59.0	I	091203
20° links; 4 Bohrungen <i>20° left; 4 bore holes</i>	4.0	4.0	9 Stützrippen <i>9 support ribs</i>	80 x 160	10	59.0	I	091249L
20° rechts; 4 Bohrungen <i>20° right; 4 bore holes</i>	4.0	4.0	9 Stützrippen <i>9 support ribs</i>	80 x 160	10	59.0	I	091249R
4 Bohrungen <i>4 bore holes</i>	3.0	4.0	12 Stützrippen <i>12 support ribs</i>	120 x 120	10	72.8	I	091246
	3.0	4.0	14 Stützrippen <i>14 support ribs</i>	120 x 160	10	93.0	I	091247

Abdeckelemente *Cover Elements*

Abdeckkappen *Cover Caps*

Einhängeprofil *Suspension Profile*



ABDECKKAPPE FÜR EINHÄNGEPROFIL

COVER CAP FOR SUSPENSION PROFILE

Ausführung	Kunststoff PA	Model	Plastic PA
Beschreibung	zum Abdecken der Profilenenden von Eihängeprofilen	Description	To seal the end openings of suspension profiles
Material	Kunststoff PA, kohlefaserverstärkt	Material	Plastic PA, carbon fiber reinforced
Farbe	schwarz	Color	Black
Liefereinheit	20 Stück	Pack Quantity	20 pieces
Extras	nicht elektrostatisch entladende Ausführung auf Anfrage	Specials	not electrostatically discharging version on request

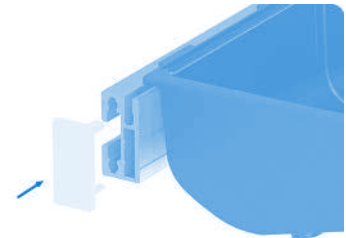
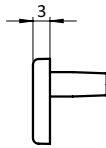
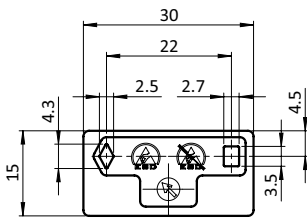

Abdeckkappe für Eihängeprofil
Cover Cap for Suspension Profile

Gewicht [g]
Weight [g]

Profil
Profile

Teil-Nr.
Part #

elektrostatisch entladend *electrostatically discharging*

1.6

B

091374S01

Abdeckelemente *Cover Elements*

Abdeckkappen *Cover Caps*

Abdeckprofil *Cover Profile*



ABDECKKAPPEN

COVER CAPS

Ausführung	Kunststoff PA	Model	Plastic PA
Beschreibung	zum Abdecken der Profilenden, passend für Aluminiumabdeckprofilstücke	Description	To cover the end of the profile, suitable for pieces of aluminum cover profiles
Material	Kunststoff PA, glasfaserverstärkt	Material	Plastic PA, glass fiber reinforced
Farbe	schwarz	Color	Black
Liefereinheit	100 Stück	Pack Quantity	100 pieces
Extras	☁ elektrostatisch entladend, weitere Größen, weitere Farben auf Anfrage	Specials	☁ electrostatically discharging, other sizes, other colors on request

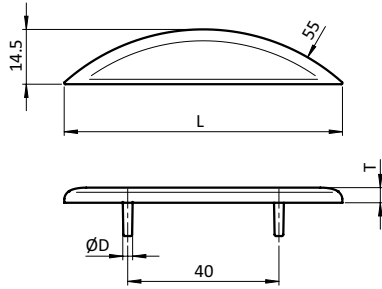

Abdeckkappe Cover Cap	L [mm]	Maße [mm] Dimensions [mm]	Gewicht [g] Weight [g]	Profil Profile	Teil-Nr. Part #
	74	R80	2.0	I	091333



CLIP 8

CLIP 8

Ausführung	Nut 8	Model	Slot 8
Beschreibung	zur Befestigung von Aluminiumabdeckprofilstücken auf Aluminiumprofil Nut 8; empfohlene Anzahl: 5 Stück auf 1 m	Description	To fix pieces of aluminum cover profiles to aluminum profiles, slot 8; recommended quantity: 5 pcs. per 1 m
Material	Federstahl	Material	Spring steel
Liefereinheit	10 Stück	Pack Quantity	10 pieces

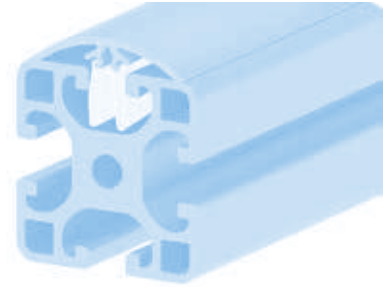
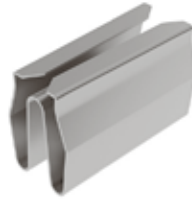
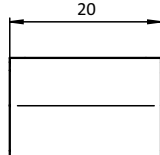
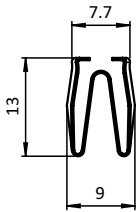









Clip 8	Gewicht [g] Weight [g]	Profil Profile	Teil-Nr. Part #
	2.6	I	092311N08

INHALTSÜBERSICHT *CONTENT OVERVIEW*



Bodenelemente <i>Floor Elements</i>	1
Scharniere <i>Hinges</i>	2
Nutmuttern und -schrauben <i>T-Nuts and T-Bolts</i>	3
Verbindungstechnik <i>Connecting Systems</i>	4
Griffe und Verschlüsse <i>Handles and Latches</i>	5
Arbeitsplatzkomponenten <i>Components for Work Stations</i>	6
Gleiter und Rollen <i>Sliders and Rollers</i>	7
Fördertechnik <i>Conveyors</i>	8
Schutz- und Trennwandelemente <i>Enclosures, Guards, Partitions</i>	9
Flächenbefestigungen <i>Panel Fasteners</i>	10
Abdeckelemente <i>Cover Elements</i>	11
Kabelführungen <i>Cable Management</i>	12
Diverse Komponenten <i>Miscellaneous Components</i>	13
Rundrohrkomponenten <i>Tubular Frame Components</i>	14

	Universal-Kabelbinderblock	<i>Universal Cable Binding Block</i>	747
	Clip-Kabelbinder	<i>Clip Cable Binder</i>	748
	Kabelbinderblock	<i>Cable Binding Block</i>	749
	Kreuz-Kabelbinderblock	<i>Cross Cable Binding Block</i>	750
	Clip-Kabelbinder mit Hammer	<i>Clip Cable Binder with Hammer</i>	751
	Clip-Kabelbinder mit Hammer	<i>Clip Cable Binder with Hammer</i>	752
	Steck-Kabelbinder mit Hammer	<i>Snap-Cable-Binding with Hammer</i>	753
	Schnellverbinder	<i>Quick Connector</i>	754



UNIVERSAL-KABELBINDERBLOCK

UNIVERSAL CABLE BINDING BLOCK

Ausführung	Kunststoff PA, Nut 5-12	Model	Plastic PA, slot 5-12
Beschreibung	zur Befestigung von Kabeln an einem Profil; Montage mittels Hammerkopfmutter o. ä.	Description	To secure cables to aluminum profiles; to be mounted with a hammer nut
Material	Kunststoff PA, glasfaserverstärkt	Material	Plastic PA, glass fiber reinforced
Farbe	schwarz	Color	Black
Liefereinheit	100 Stück	Pack Quantity	100 pieces
Extras	weitere Farben auf Anfrage	Specials	Other colors on request
Hinweis	Hammermuttern ab Seite 293 f.	Tip	Hammer nuts from page 293 et seq.

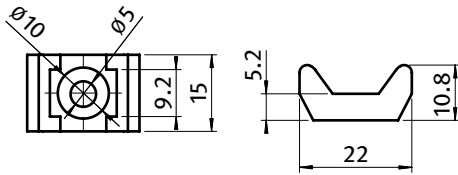

Universal-Kabelbinderblock
 Universal Cable Binding Block

Gewicht [g]
 Weight [g]
 1.6

Teil-Nr.
 Part #
 093059

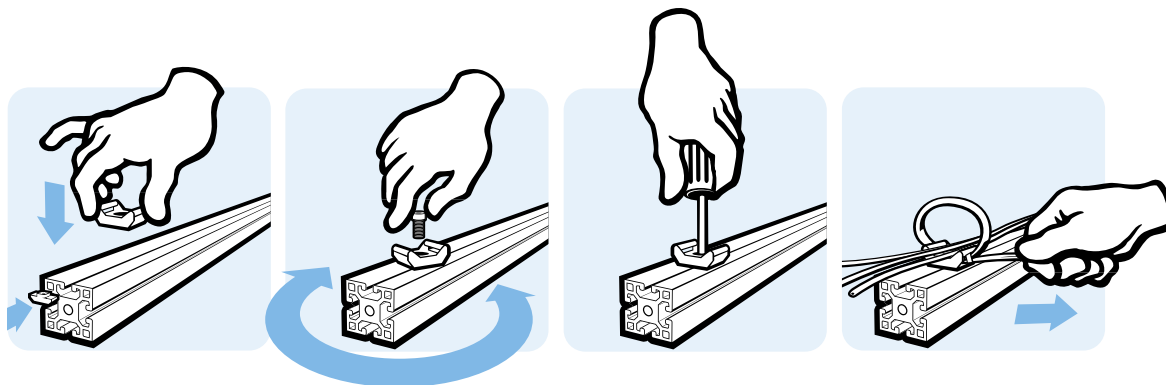

CLIP-KABELBINDER

CLIP CABLE BINDER

Ausführung	2 Kammern	Model	2 chambers
Beschreibung	zur Befestigung von Kabeln ohne zusätzlichen Kabelbinder, wiederverschließbar	Description	To fix cables without the need for cable ties, can be opened and closed again
Material	Clip: Kunststoff PA Gummi: FPM 70	Material	Clip: Plastic PA Rubber: FPM 70
Farbe	schwarz	Color	Black
Befestigung	vorderseitig mit Linsen- oder Zylinderschrauben M4	Fastening	From the front, using M4 lens or socket head screws
Liefereinheit	10 Stück	Pack Quantity	10 pieces
Extras	⚡ elektrostatisch entladend, weitere Größen, weitere Farben auf Anfrage	Specials	⚡ electrostatically discharging, other sizes, other colors on request

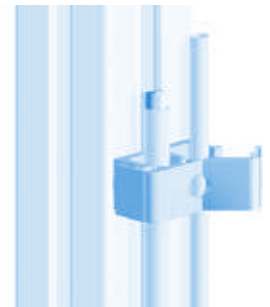
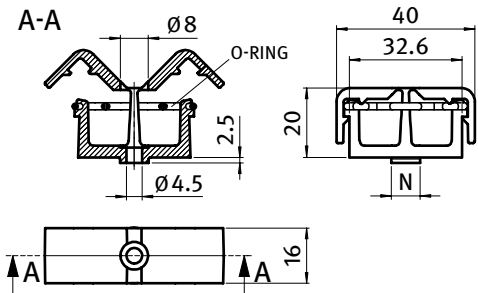

Clip-Kabelbinder Clip Cable Binder	N	Gewicht [g] Weight [g]	Teil-Nr. Part #
		7.0	093401
	8	7.0	093401N08
	10	7.0	093401N10

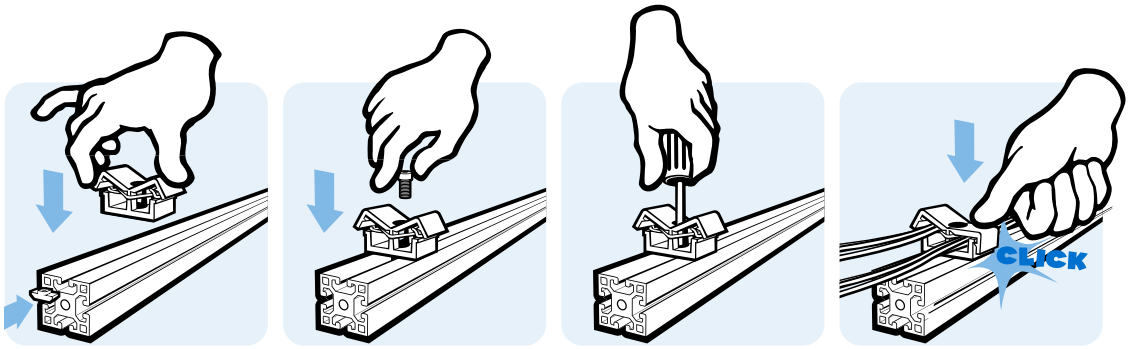



KABELBINDERBLOCK

CABLE BINDING BLOCK

Ausführung	Kunststoff PA, Nut 8, 10	Model	Plastic PA, slot 8, 10
Beschreibung	zur Befestigung von Kabeln an einem Profil; Montage mittels einer Vierteldrehung in der Nut	Description	To secure cables to aluminum profiles; can be mounted into the slot by a quarter turn
Material	Kabelbinderblock: Kunststoff PA, glasfaserverstärkt Velcro®-Klettband: Kunststoff PE (Haken), Kunststoff PA (Velours)	Material	Cable binding block: Plastic PA, glass fiber reinforced Velcro® strip: Plastic PE (hook), Plastic PA (loop)
Farbe	schwarz	Color	Black
Liefereinheit	100 Stück	Pack Quantity	100 pieces
Extras	individueller Hammer, weitere Farben auf Anfrage	Specials	Customized hammer, other colors on request

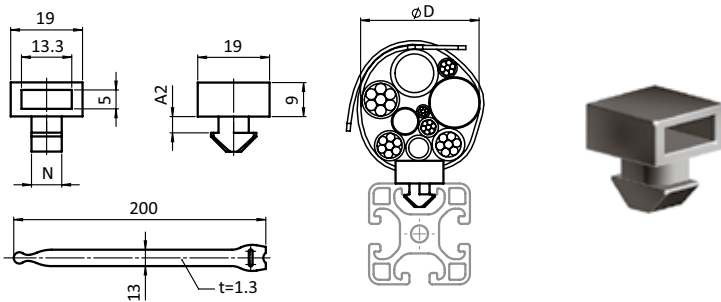

Kabelbinderblock <i>Cable Binding Block</i>	A2 (Profil) [mm] <i>A2 (Profile) [mm]</i>	N	Ø D [mm]	Gewicht [g] <i>Weight [g]</i>	Profil <i>Profile</i>	Teil-Nr. <i>Part #</i>
	4.3 (4.5)	8		3.3	I	093054
	4.4 (4.5)	8		3.5	I	093051
	1.8 (2.2)	8		3.4	B	093058
	5.9 (6.0)	10		4.0	B	093050
inklusive Velcro®-Klettband <i>With Velcro® strip</i>	4.3 (4.5)	8	≤ 50	5.0	I	093054S03
	5.9 (6.0)	10	≤ 50	5.7	B	093050S03

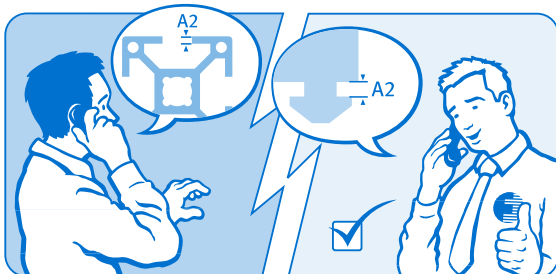
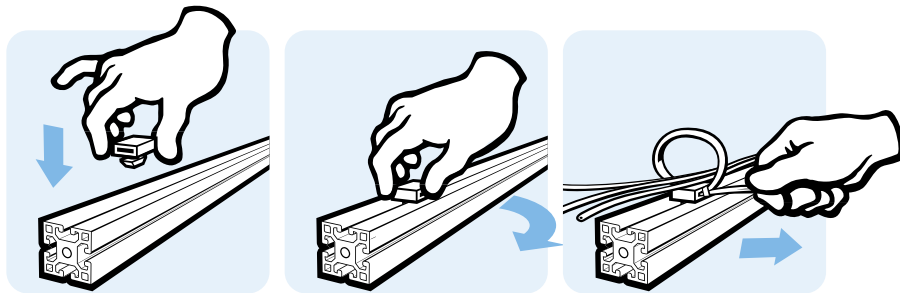



KREUZ-KABELBINDERBLOCK

CROSS CABLE BINDING BLOCK

Ausführung	Kunststoff PA, Nut 8, 10	Model	Plastic PA, slot 8, 10
Beschreibung	zur Befestigung von Kabeln sowohl längs als auch quer zum Profil; Montage mittels einer Vierteldrehung in der Nut	Description	To secure cables to aluminum profiles in two directions; can be mounted into the slot by a quarter turn
Material	Kabelbinderblock: Kunststoff PA, glasfaserverstärkt Velcro®-Klettband: Kunststoff PE (Haken), Kunststoff PA (Velour)	Material	Cable binding block: Plastic PA, glass fiber reinforced Velcro® strip: Plastic PE (hook), Plastic PA (loop)
Farbe	schwarz	Color	Black
Liefereinheit	100 Stück	Pack Quantity	100 pieces
Extras	individueller Hammer, weitere Farben auf Anfrage	Specials	Customized hammer, other colors on request

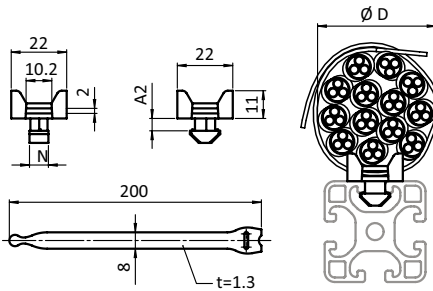

Kreuz-Kabelbinderblock Cross Cable Binding Block	A2 (Profil) [mm] A2 (Profile) [mm]	D [mm]	N	Gewicht [g] Weight [g]	Profil Profile	Teil-Nr Part#
	4.4 (4.5)		8	3.8	I	093254
	4.6 (4.5)		8	4.0	I	093251
	2.1 (2.2)		8	3.6	B	093258
	5.8 (6.0)		10	4.4	B	093249
inklusive Velcro®-Klettband With Velcro® strip	4.4 (4.5)	≤ 50	8	5.5	I	093254S03
	5.8 (6.0)	≤ 50	10	6.1	B	093249S03

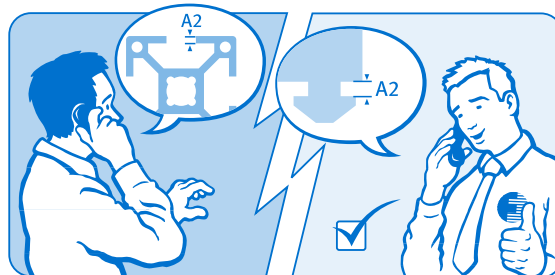



CLIP-KABELBINDER MIT HAMMER

CLIP CABLE BINDER WITH HAMMER

Ausführung 2 Kammer Kabel- und Schlauchhalter
Beschreibung zur Befestigung von Kabeln ohne zusätzlichen Kabelbinder, wiederverschließbar; Montage mittels einer Vierteldrehung in der Nut
Material Clip: Kunststoff PA
 Gummi: FPM 70
Farbe schwarz
Liefereinheit 10 Stück
Extras individueller Hammer, weitere Farben auf Anfrage

Model 2 chamber fixation for cables and tubes
Description To fix cables without the need for cable ties, can be opened and closed again; can be mounted into the slot by a quarter turn
Material Clip: Plastic PA
 Rubber: FPM 70
Color Black
Pack Quantity 10 pieces
Specials Customized hammer, other colors on request

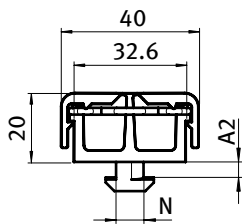
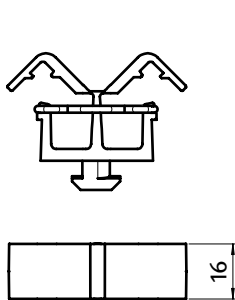

Clip-Kabelbinder mit Hammer
 Clip Cable Binder with Hammer

A2 (Profil) [mm] A2 (Profile) [mm]	N	Gewicht [g] Weight [g]	Profil Profile	Teil-Nr. Part #
1.8 (1.8)	5	7.0	I	093407N05
2.2	6.5	7.0		093408N6,5
4.0	8	6.9		093405N08
4.5 (4.5)	8	7.0	I	093402N08
2.0 (2.2)	8	7.0	B	093403N08
5.9 (6.0)	10	7.2	B	093406N10

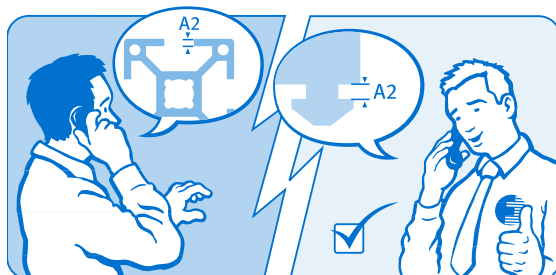
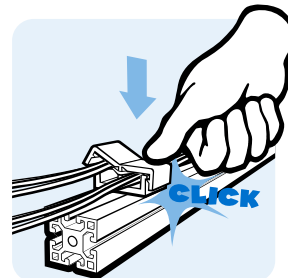
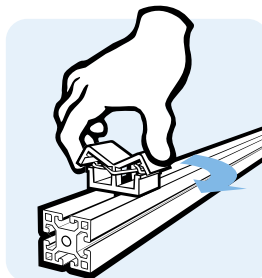
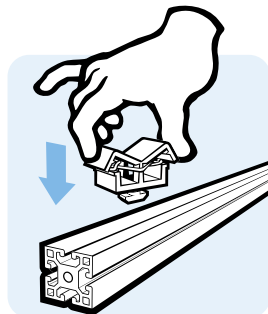

Kabelführungen *Cable Management*

Schnellverbinder *Quick Connector*

Clip-Kabelbinder mit Hammer *Clip Cable Binder with Hammer*



CLIP-KABELBINDER MIT HAMMER

CLIP CABLE BINDER WITH HAMMER

Ausführung	1 Kammer	Model	1 chamber
Beschreibung	zur Befestigung von Kabeln ohne zusätzlichen Kabelbinder, wiederverschließbar; Montage mittels einer Vierteldrehung in der Nut	Description	To fix cables without the need for cable ties, can be opened and closed again; can be mounted into the slot by a quarter turn
Material	Kunststoff PA	Material	Plastic PA
Farbe	schwarz	Color	Black
Liefereinheit	10 Stück	Pack Quantity	10 pieces

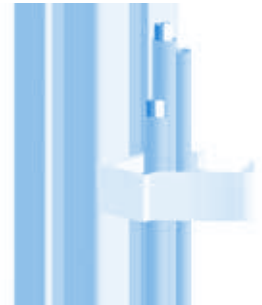
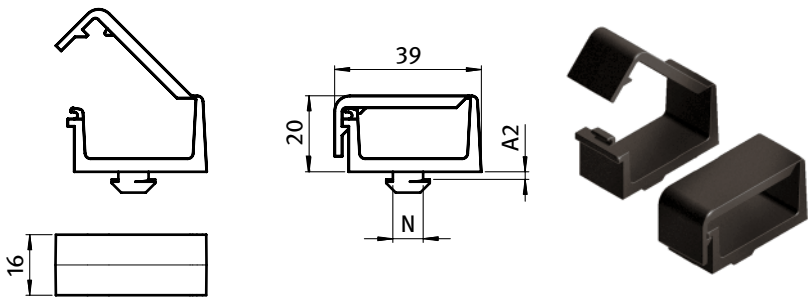

Clip-Kabelbinder mit Hammer <i>Clip Cable Binder with Hammer</i>	A2 (Profil) [mm] A2 (Profile) [mm]	N	Gewicht [g] Weight [g]	Profil Profile	Teil-Nr. Part #
	1.6 (1.8)	5	7.0	I	093510N05
	2.2	6.5	7.0		093512N6,5
	2.0 (2.0)	8	7.0	B	093504N08
	4.5 (4.5)	8	7.0	I	093505N08
	5.9 (6.0)	10	7.0	B	093506N10

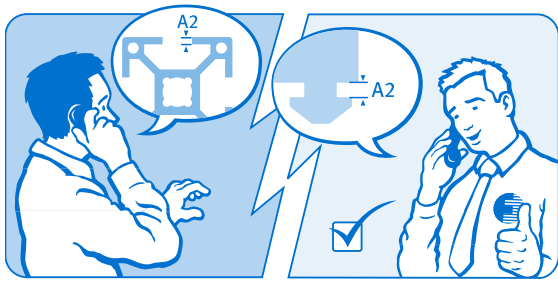
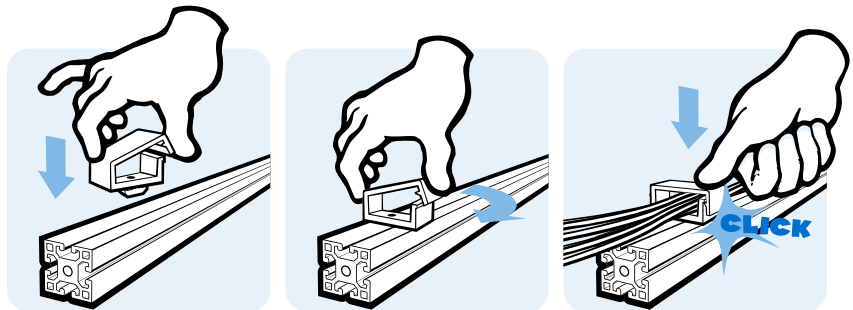



STECK-KABELBINDER MIT HAMMER

SNAP-CABLE-BINDING WITH HAMMER

Ausführung	für Ø 5,0 - 7,6 mm Außendurchmesser	Model	For Ø 5.0 - 7.6 mm outside diameter
Beschreibung	zur schnellen und sicheren Befestigung von Kabeln ohne Kabelbinder, mit Zugentlastung; Montage mittels einer Vierteldrehung in der Nut oder durch Einstecken	Description	To attach of cables securely and quick and without cable ties, with strain relief; can be mounted into the slot by a quarter turn or by snapping in
Material	Kunststoff PA	Material	Plastic PA
Liefereinheit	100 Stück	Pack Quantity	100 pieces

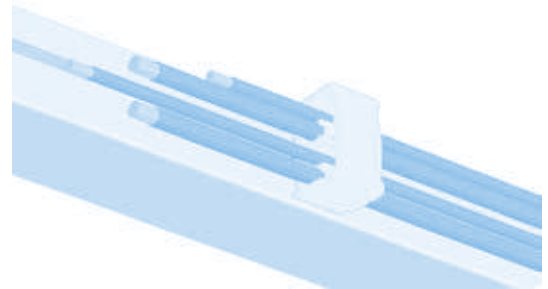
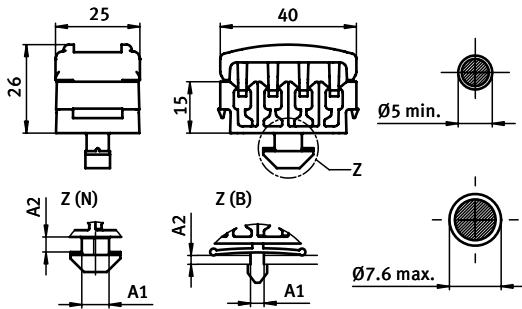

Abdeckkappe Cover Cap	Bohrung Hole	Steck-Kabelbinder Snap-cable-binding	A1 [mm]	A2 (Profil) [mm] A2 (Profile) [mm]	N	Gewicht [g] Weight [g]	Profil Profile	Teil-Nr Part#
ohne Without		(N) Hammer für Nut (N) Hammer for slot	8.0	4.4 (4.5)	8	10.8	I	093611N08
		(N) Hammer für Nut (N) Hammer for slot	10.0	5.7 (6.0)	10	10.4	B	093610N10
	Ø 6.0 +0.3	(B) Steckhammer für Loch (B) Snap-hammer for hole		0.7 - 3.0		10.7		093600B06
	Ø 8.0 +0.3	(B) Steckhammer für Loch (B) Snap-hammer for hole		0.7 - 3.0		11.7		093600B08
mit With		(N) Hammer für Nut (N) Hammer for slot	8.0	4.4 (4.5)	8	10.8	I	093611AN08
		(N) Hammer für Nut (N) Hammer for slot	10.0	5.7 (6.0)	10	10.4	B	093610AN10
	Ø 6.0 +0.3	(B) Steckhammer für Loch (B) Snap-hammer for hole		0.7 - 3.0		10.7		093600AB06
	Ø 8.0 +0.3	(B) Steckhammer für Loch (B) Snap-hammer for hole		0.7 - 3.0		11.7		093600AB08

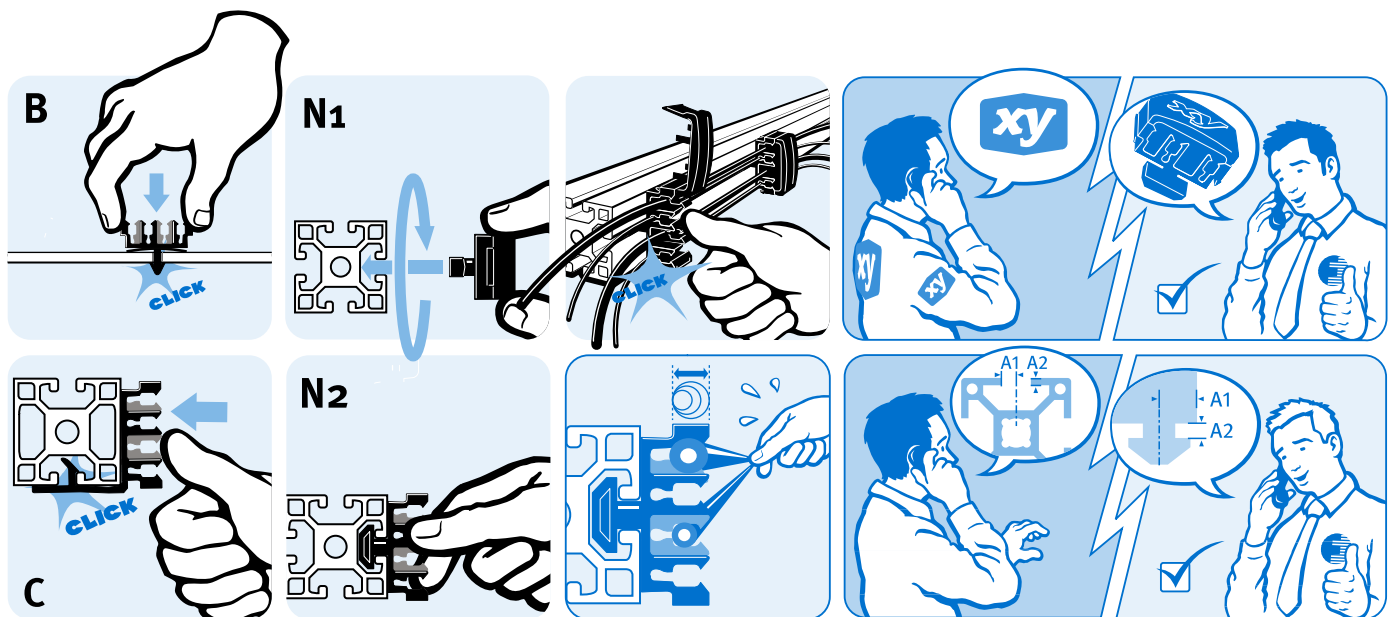



SCHNELLVERBINDER

QUICK CONNECTOR

Ausführung	für Kabelkanäle	Model	For cable ducts
Beschreibung	zur Befestigung von Kabelkanälen an Aluminiumprofilen	Description	To fasten cable ducts to aluminum profiles
Material	Kunststoff PA, glasfaserverstärkt	Material	Plastic PA, glass fiber reinforced
Farbe	schwarz	Color	Black
Liefereinheit	100 Stück	Pack Quantity	100 pieces

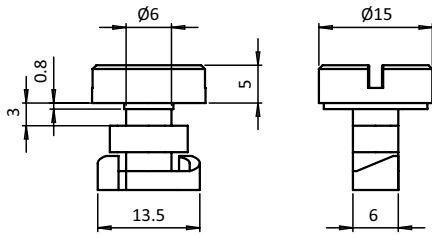

Schnellverbinder Quick Connector	N	Gewicht [g] Weight [g]	Profil Profile	Teil-Nr. Part #
	10	3.0	B	093QFN10

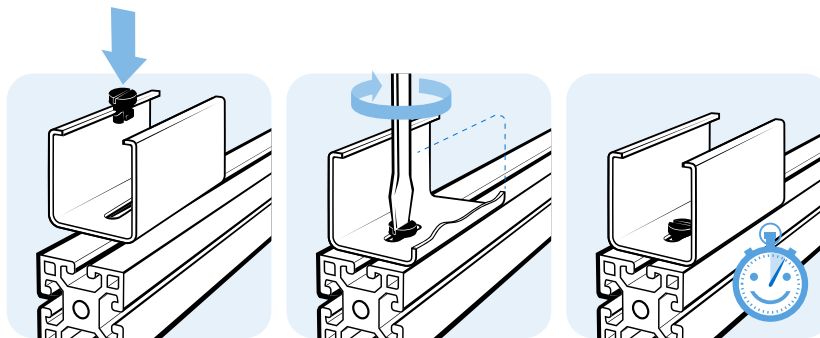



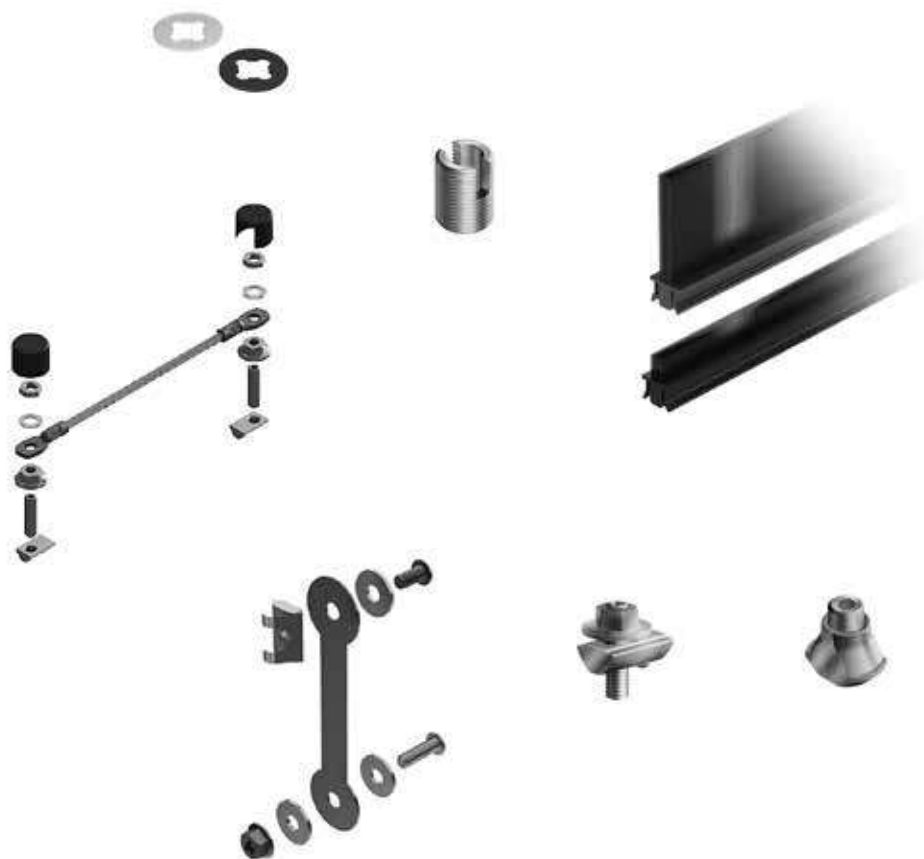



INHALTSÜBERSICHT *CONTENT OVERVIEW*



Bodenelemente <i>Floor Elements</i>	1
Scharniere <i>Hinges</i>	2
Nutmuttern und -schrauben <i>T-Nuts and T-Bolts</i>	3
Verbindungstechnik <i>Connecting Systems</i>	4
Griffe und Verschlüsse <i>Handles and Latches</i>	5
Arbeitsplatzkomponenten <i>Components for Work Stations</i>	6
Gleiter und Rollen <i>Sliders and Rollers</i>	7
Fördertechnik <i>Conveyors</i>	8
Schutz- und Trennwandelemente <i>Enclosures, Guards, Partitions</i>	9
Flächenbefestigungen <i>Panel Fasteners</i>	10
Abdeckelemente <i>Cover Elements</i>	11
Kabelführungen <i>Cable Management</i>	12
Diverse Komponenten <i>Miscellaneous Components</i>	13
Rundrohrkomponenten <i>Tubular Frame Components</i>	14



	Gewindebuchse	<i>Threaded Bush</i>	757
	Potenzialausgleich	<i>Potential Equalizer</i>	758
	Erdungsverbinder (Set)	<i>Grounding Connector (Set)</i>	759
	Set Potenzialausgleich	<i>Set Potential Equalizer</i>	760
	Erdungsanschluß	<i>Grounding Terminal</i>	761
	Leistenbürste	<i>Strip Brush</i>	762
	Unverlierbarkeits- scheibe	<i>Anti-loss Washer</i>	763

GEWINDEBUCHSE

THREADED BUSH

Ausführung	selbstschneidend, Stahl	Model	<i>Self tapping, steel</i>
Beschreibung	zur Aufnahme von Stellfüßen oder zur Befestigung von Transport- und Fußplatten	Description	<i>To fix leveling feet or transport and base plates to the aluminum profile</i>
Material	Stahl	Material	<i>Steel</i>
Liefereinheit	100 Stück	Pack Quantity	<i>100 pieces</i>

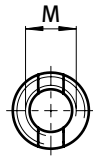
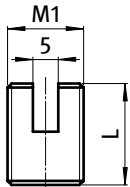

Gewindebuchse <i>Threaded Bush</i>	L [mm]	M	M1	Gewicht [g] <i>Weight [g]</i>	Teil-Nr. <i>Part #</i>
	20	M6	M15	16.0	340ME110
	20	M8	M15	15.0	340ME111
	20	M10	M15	15.0	340ME112



POTENTIALAUSGLEICH

POTENTIAL EQUALIZER

Ausführung	Nut 8, Stahl verzinkt	Model	Slot 8, zinc plated steel
Beschreibung	zur Herstellung einer elektrostatischen Ableitung zwischen zwei Aluminiumprofilen Nut 8	Description	To make an electrostatically discharging connection between two slot 8 aluminum profiles
Material	Stahl, verzinkt	Material	Zinc plated steel
Liefereinheit	10 Stück	Pack Quantity	10 pieces

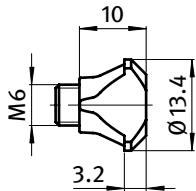
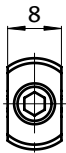

Potentialausgleich	N	Gewicht [g] Weight [g]	Profil Profile	Teil-Nr. Part #
elektrostatisch entladend elektrostatisch entladend	8	5.2	I	093090



ERDUNGSVERBINDER (SET)

GROUNDING CONNECTOR (SET)

Ausführung	Nut 8, 10	Model	Slot 8, 10
Beschreibung	zum elektrischen Anschluss beweglicher Bauteile untereinander als flexible Schutzleitung, und zum elektrostatisch ableitenden Verbinden benachbarter Gestelle als Potentialausgleich; großer Leitungsquerschnitt von 16 mm ² , Strombelastbarkeit max. 120 A	Description	To electrically connect movable parts to each other as flexible grounding wire, and to create electrically conductive connections between juxtaposed frames as equipotential bonding; large conductor cross-section (16 mm ²), current carrying capacity 120 A max.
Material	Erdungslitze: Kupfer Montagematerial: Stahl Abdeckkappen: Kunststoff PA, glasfaserverstärkt	Material	Earth lead: Copper Assembly material: Steel Cover caps: Plastic PA, glas fiber reinforced
Farbe	Abdeckkappen: schwarz	Color	Cover caps: Black
Set 1	(Aufzählung in Montager Reihenfolge inkl. Anzugsmomente): 2 Nutensteine - Nut 8 - M8, 2 Gewindestifte DIN 916 - M8 x 30 (M = 10 Nm), 2 Sechskantmuttern mit Flansch DIN 6923 - M8 (M = 34 Nm), 1 Erdungslitze 200 mm, 2 Zahnscheiben DIN 6798 - 8,4, 2 Sechskantmuttern DIN 439 B - M8 (M = 25 Nm), 2 Abdeckkappen	Set 1	(Listed in assembly sequence incl. tightening torques): 2 T-slot nuts - slot 8 - M8, 2 threaded pins DIN 916 - M8 x 30 (M = 10 Nm), 2 flanged hexagon nuts DIN 6923 - M8 (M = 34 Nm), 1 earth lead 200 mm, 2 serrated lock washers DIN 6798 - 8.4, 2 hexagon nuts DIN 439 B - M8 (M = 25 Nm), 2 cover caps
Set 2	(Aufzählung in Montager Reihenfolge inkl. Anzugsmomente): 2 Nutensteine - Nut 10 - M8, 2 Gewindestifte DIN 916 - M8 x 30 (M = 10 Nm), 2 Sechskantmuttern mit Flansch DIN 6923 - M8 (M = 34 Nm), 1 Erdungslitze 200 mm, 2 Zahnscheiben DIN 6798 - 8,4, 2 Sechskantmuttern DIN 439 B - M8 (M = 25 Nm), 2 Abdeckkappen	Set 2	(Listed in assembly sequence incl. tightening torques): 2 T-slot nuts - slot 10 - M8, 2 threaded pins DIN 916 - M8 x 30 (M = 10 Nm), 2 flanged hexagon nuts DIN 6923 - M8 (M = 34 Nm), 1 earth lead 200 mm, 2 serrated lock washers DIN 6798 - 8.4, 2 hexagon nuts DIN 439 B - M8 (M = 25 Nm), 2 cover caps
Set 3	(Aufzählung in Montager Reihenfolge inkl. Anzugsmomente): 2 Nutensteine - Nut 8 - M8, 2 Gewindestifte DIN 916 - M8 x 30 (M = 10 Nm), 2 Sechskantmuttern mit Flansch DIN 6923 - M8 (M = 34 Nm), 1 Erdungslitze 300 mm, 2 Zahnscheiben DIN 6798 - 8,4, 2 Sechskantmuttern DIN 439 B - M8 (M = 25 Nm), 2 Abdeckkappen	Set 3	(Listed in assembly sequence incl. tightening torques): 2 T-slot nuts - slot 8 - M8, 2 threaded pins DIN 916 - M8 x 30 (M = 10 Nm), 2 flanged hexagon nuts DIN 6923 - M8 (M = 34 Nm), 1 earth lead 300 mm, 2 serrated lock washers DIN 6798 - 8.4, 2 hexagon nuts DIN 439 B - M8 (M = 25 Nm), 2 cover caps
Liefereinheit	10 Stück	Pack Quantity	10 pieces

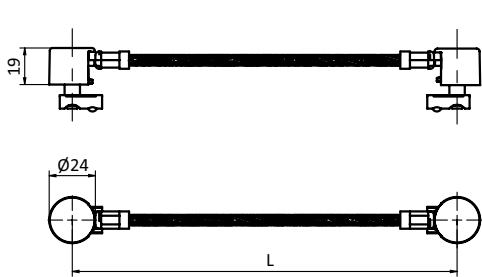

Erdungsverbinder (Set) Grounding Connector (Set)	L [mm]	N	Gewicht [g] Weight [g]	Profil Profile	Teil-Nr. Part #
Set 1	200.0	8	114.0	I	093099S01
Set 2	200.0	10	108.0	B	093099S02
Set 3	300.0	8	145.0	I	093099S03



SET POTENTIALAUSGLEICH

SET POTENTIAL EQUALIZER

<p>Ausführung Nut 10, Edelstahl</p> <p>Beschreibung zur Herstellung einer elektrostatischen Ableitung zwischen Flächenelement und Aluminiumprofil</p> <p>Material Edelstahl 1.4301</p> <p>Set 1 Potentialausgleich, 1 Linsenkopfschraube ISO 7380 - M6 x 12, 1 Nutenstein mit Feder, Nut 10 mit Steg, M6, 3 Scheiben DIN 9021 - 6.4, 1 Flanschmutter DIN 9023 - M6, 1 Linsenkopfschraube ISO 7380 - M6 x 20</p> <p>Liefereinheit 10 Stück</p>	<p>Model Slot 10, stainless steel</p> <p>Description To make an electrostatically discharging connection between panel and aluminum profile</p> <p>Material Stainless steel SS304</p> <p>Set 1 potential equalizer, 1 pan-head screw ISO 7380 - M6 x 12, 1 -slot nut with spring, Nut 10 mit Steg, M6, 3 washers DIN 9021 - 6.4, 1 flange nut DIN 9023 - M6, 1 pan-head screw ISO 7380 - M6 x 20</p> <p>Pack Quantity 10 pieces</p>
---	---

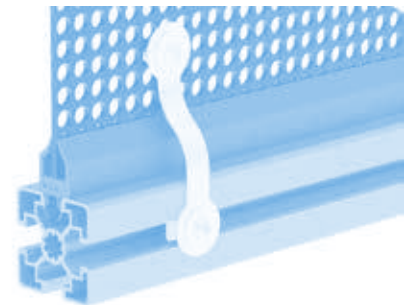
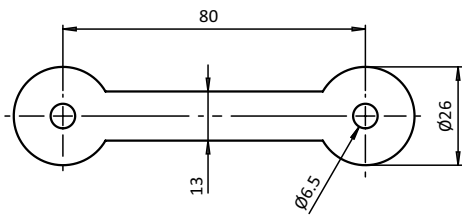

Set Potentialausgleich Set Potential Equalizer	N	Gewicht [g] Weight [g]	Profil Profile	Teil-Nr. Part #
elektrostatisch entladend elektrostatisch discharging	10	39.0	B	093096S01



ERDUNGSANSCHLUß

GROUNDING TERMINAL

Ausführung	Nut 8	Model	Slot 8
Beschreibung	zur Herstellung einer elektrostatischen Ableitung	Description	To make an electrostatically discharging connection
Material	Nutenstein, Gewindestift, Fächerscheibe: Stahl, verzinkt Mutter, Scheibe: Messing	Material	T-Slot Nut, grub screw, serrated washer: Zinc plated steel Hexagon nut, washer: Brass
Liefereinheit	10 Stück	Pack Quantity	10 pieces

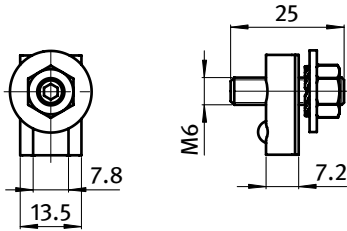

Erdungsanschluß <i>Grounding Terminal</i>	N	Gewicht [g] <i>Weight [g]</i>	Profil <i>Profile</i>	Teil-Nr. <i>Part #</i>
elektrostatisch entladend <i>electrostatically discharging</i>	8	19.0	I	093091



LEISTENBÜRSTE

STRIP BRUSH

Ausführung	Kunststoff, Nut 8, 10	Model	Plastic, slot 8, 10
Beschreibung	zum Abdichten, Tragen, Reinigen, Führen und Fixieren	Description	To tighten, carry, clean, guide and fix
Material	Körper: Kunststoff ABS Fasern: Kunststoff PA	Material	Body: Plastic ABS Bristles: Plastic PA
Farbe	Körper: schwarz Fasern: schwarz	Color	Body: Black Bristles: Black
Liefereinheit	20 m (20 Stück à 1 m)	Pack Quantity	20 m (20 pieces at 1 m)
Extras	weitere Größen (FH, ØFD) sowie Polyester PBT-Fasern für Feucht- / Außenbereich auf Anfrage	Specials	Other sizes (FH, ØFD), polyester PBT bristles for exterior and humid areas on request

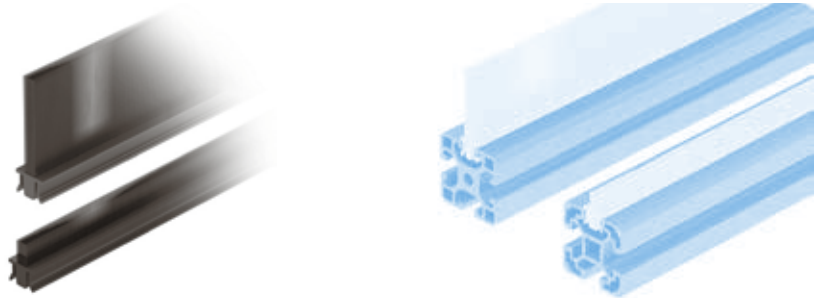
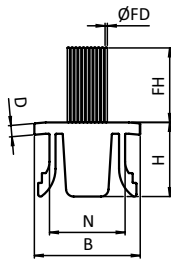

Leistenbürste <i>Strip Brush</i>	B [mm]	D [mm]	FH [mm]	H [mm]	N	ØFD [mm]	Gewicht [g] <i>Weight [g]</i>	Teil-Nr <i>Part#</i>
	12.0	1.5	10.0	8.5	8	0.2	94.0	093SB10N08
	12.0	1.5	40.0	8.5	8	0.2	139.0	093SB40N08
	14.0	1.5	10.0	9.8	10	0.2	110.0	093SB10N10
	14.0	1.5	40.0	9.8	10	0.2	170.0	093SB40N10
⚡ elektrostatisch entladend <i>electrostatically discharging</i>	12.0	1.5	10.0	8.5	8	0.2	94.0	093SB10N08ESD
	12.0	1.5	40.0	8.5	8	0.2	139.0	093SB40N08ESD
	14.0	1.5	10.0	9.8	10	0.2	110.0	093SB10N10ESD
	14.0	1.5	40.0	9.8	10	0.2	170.0	093SB40N10ESD

UNVERLIERBARKEITSSCHEIBE

ANTI-LOSS WASHER

Ausführung	für Schrauben M5, M6 und M8	Model	For screws with thread M5, M6, and M8
Beschreibung	zum einfachen und schnellen Sichern von Schrauben gegen Verlust	Description	To easily and fastly secure screws against loss
Material	Kunststoff PA	Material	Plastic PA
Liefereinheit	1000 Stück	Pack Quantity	1000 pieces
Extras	weitere Größen auf Anfrage	Specials	Other sizes on request

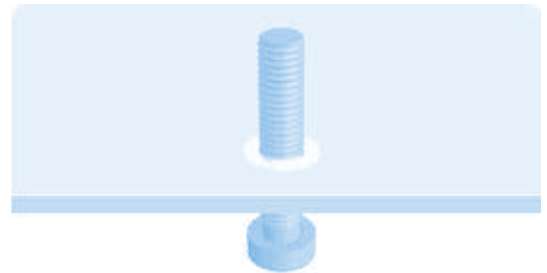
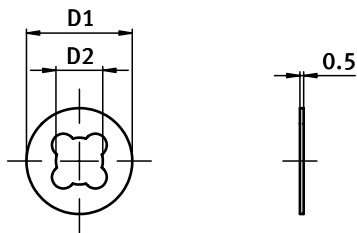





















Unverlierbarkeitsscheibe <i>Anti-loss washer</i>	D1 [mm]	D2 [mm]	Farbe	für Schraube <i>for Screw</i>	Gewicht [g] <i>Weight [g]</i>	Teil-Nr. <i>Part #</i>
	10.0	4.1	schwarz <i>Black</i>	M5	1.0	093169SW
	12.0	5.1	schwarz <i>Black</i>	M6	1.0	093166SW
	10.0	4.1	natur <i>Nature</i>	M5	1.0	093169
	12.0	5.1	natur <i>Nature</i>	M6	1.0	093166
	14.0	6.2	natur <i>Nature</i>	M8	1.0	093156

INHALTSÜBERSICHT *CONTENT OVERVIEW*



Bodenelemente <i>Floor Elements</i>	1
Scharniere <i>Hinges</i>	2
Nutmuttern und -schrauben <i>T-Nuts and T-Bolts</i>	3
Verbindungstechnik <i>Connecting Systems</i>	4
Griffe und Verschlüsse <i>Handles and Latches</i>	5
Arbeitsplatzkomponenten <i>Components for Work Stations</i>	6
Gleiter und Rollen <i>Sliders and Rollers</i>	7
Fördertechnik <i>Conveyors</i>	8
Schutz- und Trennwandelemente <i>Enclosures, Guards, Partitions</i>	9
Flächenbefestigungen <i>Panel Fasteners</i>	10
Abdeckelemente <i>Cover Elements</i>	11
Kabelführungen <i>Cable Management</i>	12
Diverse Komponenten <i>Miscellaneous Components</i>	13
Rundrohrkomponenten <i>Tubular Frame Components</i>	14



	Gleitleiste D28	<i>Slide Rail D28</i>	767		Varioblock AL D28	<i>Vario Block AL D28</i>	786
	Set Gewindehülse D28	<i>Set Threaded Sleeve D28</i>	768		Varioblock D28 (Set)	<i>Vario Block D28 (Set)</i>	787
	Abdeckkappe D28	<i>Cover Cap D28</i>	769				
	Set T-Verbinder D28	<i>Set T-Connector D28</i>	770				
	Set T-Verbinder D28, Nut 10	<i>Set T-Connector D28, Slot 10</i>	771				
	Set Eckverbinder 2D28	<i>Set Corner Connector 2D28</i>	772				
	Set Winkelverbinder 2D28	<i>Set Angle Connector 2D28</i>	773				
	Kugel-Stoßverbinder D28 (Set)	<i>Ball Butt Connector D28 (Set)</i>	774				
	Set Adapterplatte D28	<i>Set Adapter Plate D28</i>	775				
	T-Verbinderplatte D28	<i>T-Connector Plate D28</i>	776				
	Set Haltewinkel 60 x 47 x 4, D28	<i>Set Mounting Brackets 60 x 47, D28</i>	777				
	Set Winkelverbinder D28, 45°	<i>Set Angle Connector D28, 45°</i>	778				
	Set Kugelverbinder D28	<i>Set Ball Connector D28</i>	779				
	Set Kreuzverbinder D28	<i>Set Cross Connector D28</i>	780				
	Set Parallelverbinder D28	<i>Set Parallel Connector D28</i>	781				
	Set Parallelklemme D28	<i>Set Parallel Clamp D28</i>	782				
	Set Befestigungsklemme D28	<i>Set Mounting Clamp D28</i>	783				
	Einhängeplatte D28 / D30	<i>Suspension Plate D28 / D30</i>	784				
	Beschriftungsclip D28	<i>Label Clip D28</i>	785				



GLEITLEISTE D28

SLIDE RAIL D28

Ausführung	Kunststoff PA	Model	Plastic PA
Beschreibung	zum Herstellen einfacher Gleitbahnen durch Aufclipsen auf ein Rundrohrprofil mit Außendurchmesser Ø 28 mm; auch als Auflage einsetzbar bei Montage von Flächenelementen mit Varioblock AL D28	Description	To build simple slipways by clipping on a tubular frame profile with Ø 28 mm outer diameter; also applicable as support strip for the mouting of panels with vario block AL D28
Material	Kunststoff PVC-U	Material	Plastic PVC-U
Farbe	schwarz, grau	Color	Black, gray
Liefereinheit	200 Meter (100 St. á 2 m)	Pack Quantity	200 meters (100 pieces at 2 m)
Hinweis	Bitte beachten: Sie bestellen in Meter!; passender Varioblock AL D28 siehe Seite 786	Tip	Please note: You are ordering in meters! Compatible vario block see page 786

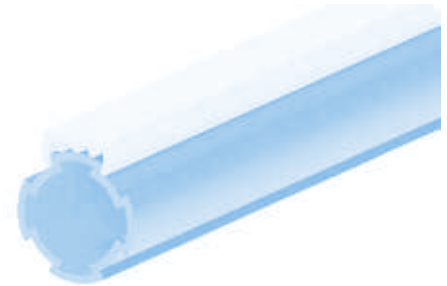
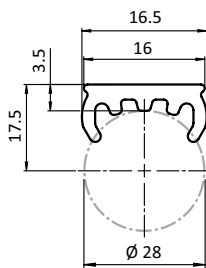

Gleitleiste D28 Slide Rail D28	Gewicht [g/m] Weight [g/m]	Profil Profile	Teil-Nr. Part #
schwarz, elektrostatisch entladend <i>Black, electrostatically discharging</i>	66.0	B	092060S01
grau ≈ RAL 7035 <i>Gray</i>	66.0	B	092060



GEWINDEHÜLSE D28

THREADED SLEEVE D28

<p>Ausführung für Rundrohrprofile</p> <p>Beschreibung zur Befestigung von Stellfüßen und Lenkrollen an der Stirnseite von Rundrohrprofilen mit Außendurchmesser \varnothing 28 mm</p> <p>Material Hülse: Kunststoff PA, elektrostatisch entladend, Langmutter: Stahl</p> <p>Farbe Hülse: schwarz</p> <p>Set 1 Hülse, 2-teilig, 1 Langmutter M12</p> <p>Liefereinheit 20 Stück</p>	<p>Model For tubular frame profiles</p> <p>Description To fix leveling feet or swivel castors to the front of tubular frame profiles with \varnothing 28 mm outer diameter</p> <p>Material Sleeve: Plastic PA, electrostatically discharging, Long nut: Steel</p> <p>Color Sleeve: Black</p> <p>Set 1 Sleeve, two-part, 1 long nut</p> <p>Pack Quantity 20 pieces</p>
---	---

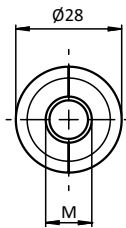
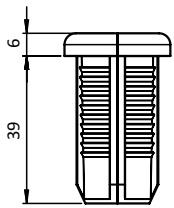

Set Gewindehülse D28
Threaded Sleeve D28

Gewicht [g]
Weight [g]

Teil-Nr.
Part #

M12

24.0

099RV28AS01



ABDECKKAPPE D28

COVER CAP D28

Ausführung	für Rundrohrprofile	Model	For tubular frame profiles
Beschreibung	zum Abdecken der Profilenden von Rundrohrprofilen mit Außendurchmesser Ø 28 mm	Description	To cover the end of a tubular frame profile with Ø 28 mm outer diameter
Material	Kunststoff PA, glasfaserverstärkt	Material	Plastic PA, glass fiber reinforced
Farbe	schwarz	Color	Black
Liefereinheit	100 Stück	Pack Quantity	100 pieces
Extras	weitere Größen, weitere Farben auf Anfrage	Specials	Other sizes, other colors on request



Abdeckkappe D28 Cover Cap D28	Gewicht [g] Weight [g]	Profil Profile	Teil-Nr. Part #
(A) Abdeckkappe D28, elektrostatisch entladend (A) Cover cap D28, electrostatically discharging	3.0	B	099RV28CC01
(B) Abdeckkappe D28 N10, elektrostatisch entladend (B) Cover cap D28 N10, electrostatically discharging	2.5	B	099RV28CC02



SET T-VERBINDER D28

SET T-CONNECTOR D28

<p>Ausführung für Rundrohrprofile</p> <p>Beschreibung zur rechtwinkligen Verbindung von zwei Rundrohrprofilen mit Außendurchmesser \varnothing 28 mm</p> <p>Material Verbinder: Aluminiumdruckguss Montageset: Stahl</p> <p>Set 2 Elemente für T-Verbinder D28, 1 Schraube DIN 912 - M6 \times 25, 1 selbstsichernde Mutter ISO 10511 - M6</p> <p>Liefereinheit 10 Stück</p>	<p>Model For tubular frame profiles</p> <p>Description To connect two tubular frame profiles with \varnothing 28 mm outer diameter at right angles</p> <p>Material Connector: Aluminum die-cast Assembly set: Steel</p> <p>Set 2 components for T-connector D28, 1 screw DIN 912 - M6 \times 25, 1 self-locking nut ISO 10511 - M6</p> <p>Pack Quantity 10 pieces</p>
---	--

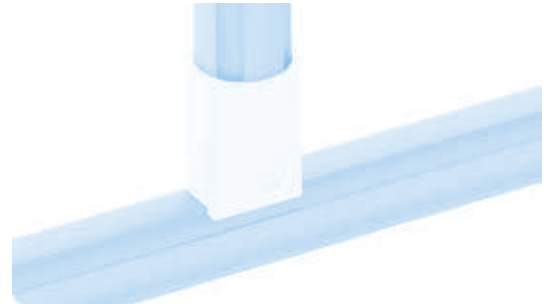
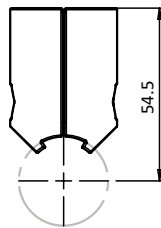
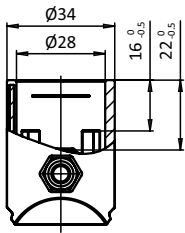

Set T-Verbinder D28

Gewicht [g]
Weight [g]

Teil-Nr.
Part #

elektrostatisch entladend electrostatically discharging

56.0

099RV2890LS01



SET T-VERBINDER D28, NUT 10

SET T-CONNECTOR D28, SLOT 10

<p>Ausführung für Rundrohrprofile</p> <p>Beschreibung zur rechtwinkligen Verbindung von einem Rundrohrprofil mit Außendurchmesser \varnothing 28 mm mit einem Aluminiumprofil Nut 10</p> <p>Material Verbinder: Aluminiumdruckguss Abdeckkappe: Kunststoff PA, glasfaserverstärkt Montageset: Stahl</p> <p>Set 1 T-Verbinder D28, Nut 10, 1 Abdeckkappe, 1 selbstformende Schraube S8 x 25, Torx T40, 1 Flanschmutter M8, 1 Hammerschraube - Nut 10 - M8 x 20</p> <p>Liefereinheit 10 Stück</p>	<p>Model For tubular frame profiles</p> <p>Description To connect a tubular frame profile with \varnothing 28 mm outer diameter with a slot 10 aluminum profile</p> <p>Material Connector: Aluminum die-cast Cover cap: Plastic PA Assembly set: Steel</p> <p>Set 1 T-connector D28, slot 10, 1 cover cap, 1 self-tapping screw S8 x 25, Torx T40, 1 flange nut M8, 1 hammer head screw - Nut 10 - M8 x 20</p> <p>Pack Quantity 10 pieces</p>
---	---

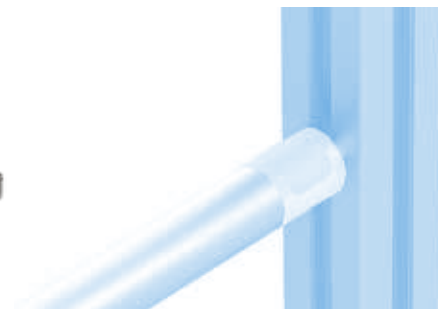
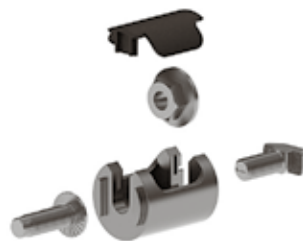
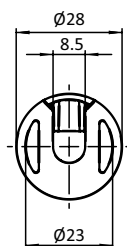
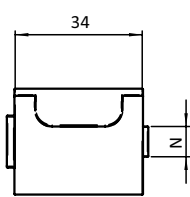

Set T-Verbinder D28, Nut 10
Set T-Connector D28, Slot 10

N

Gewicht [g]
Weight [g]

Teil-Nr.
Part #

10

62.0

099RV28TS01



SET ECKVERBINDER 2D28

SET CORNER CONNECTOR 2D28

<p>Ausführung für Rundrohrprofile</p> <p>Beschreibung zur rechtwinkligen Verbindung von zwei Rundrohrprofilen mit Außendurchmesser $\varnothing 28$ mm, mit Verdrehsicherung; komplett vormontiertes Set</p> <p>Material Verbinder: Aluminiumdruckguss Montageset: Stahl</p> <p>Set 2 Elemente für Eckverbinder 2D28, 1 Schraube DIN 912 - M6 \times 25, 1 selbstsichernde Mutter ISO 10511 - M6</p> <p>Liefereinheit 10 Stück</p>	<p>Model For tubular frame profiles</p> <p>Description To connect two tubular frame profiles with $\varnothing 28$ mm outer diameter at right angles; with pre-centering; completely pre-assembled set</p> <p>Material Connector: Aluminum die-cast Assembly set: Steel</p> <p>Set 2 components for corner connector 2D28, 1 screw DIN 912 - M6 \times 25, 1 self-locking nut ISO 10511 - M6</p> <p>Pack Quantity 10 pieces</p>
---	--

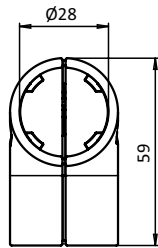
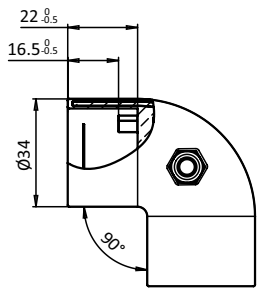

Set Winkelverbinder 2D28
Set Corner Connector 2D28

Gewicht [g]
Weight [g]

Teil-Nr.
Part #

elektrostatisch entladend electrostatically discharging

98.0

099RV28ES01

Rundrohrkomponenten *Tubular Frame Components*

Rundrohrverbinder *Tubular Frame Connectors*

90°-Verbinder *90°-Connector*



SET WINKELVERBINDER 2D28

SET ANGLE CONNECTOR 2D28

<p>Ausführung für Rundrohrprofile</p> <p>Beschreibung zur rechtwinkligen Verbindung von zwei Rundrohrprofilen mit Außendurchmesser $\varnothing 28$ mm, mit Verdrehsicherung; komplett vormontiertes Set</p> <p>Material Verbinder: Aluminiumdruckguss Montageset: Stahl</p> <p>Set 2 Elemente für Winkelverbinder 2D28, 2 Schrauben DIN 912 - M6 \times 25, 2 selbstsichernde Muttern ISO 10511 - M6</p> <p>Liefereinheit 10 Stück</p>	<p>Model For tubular frame profiles</p> <p>Description To connect two tubular frame profiles with $\varnothing 28$ mm outer diameter at right angles; with pre-centering; completely pre-assembled set</p> <p>Material Connector: Aluminum die-cast Assembly set: Steel</p> <p>Set 2 components for angle connector 2D28, 2 screws DIN 912 - M6 \times 25, 2 self-locking nuts ISO 10511 - M6</p> <p>Pack Quantity 10 pieces</p>
--	---

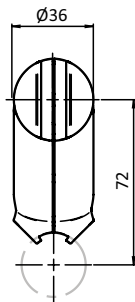
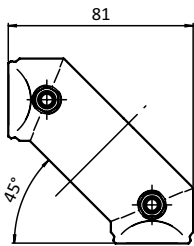

Set Winkelverbinder 2D28
Set Angle Connector 2D28

Gewicht [g]
Weight [g]

Teil-Nr.
Part #

elektrostatisch entladend electrostatically discharging

134.0

099RV2890QS01



KUGEL-STOßVERBINDER D28 (SET)

BALL BUTT CONNECTOR D28 (SET)

<p>Ausführung für Rundrohrprofile</p> <p>Beschreibung zur Verbindung von zwei Rundrohrprofilen mit Außendurchmesser \varnothing 28mm, mit Verdrehsicherung; komplett vormontiertes Set</p> <p>Material Verbinder: Aluminiumdruckguss Montageset: Stahl</p> <p>Oberfläche Verbinder: blank Montageset: verzinkt</p> <p>Liefereinheit 10 Stück</p> <p>Set 4 Elemente für Kugelverbinder D28, 2 Schrauben DIN 912 - M6 \times 25, 2 selbstsichernde Mutter ISO 10511 - M6</p>	<p>Model For tubular frame profiles</p> <p>Description To connect two tubular frame profiles with \varnothing 28 mm outer diameter at variable angles; with pre-centering; completely pre-assembled set</p> <p>Material Connector: Aluminum die-cast Assembly set: Steel</p> <p>Surface Connector: Plain Assembly set: Zinc plated</p> <p>Pack Quantity 10 pieces</p> <p>Set 4 components for ball connector D28, 2 screws DIN 912 - M6 \times 25, 2 self-locking nuts ISO 10511 - M6</p>
--	---

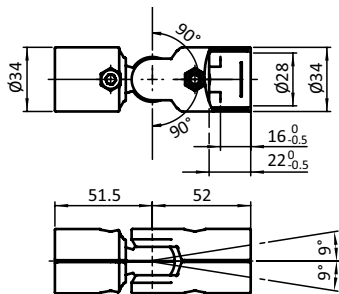

Kugel-Stoßverbinder D28 (Set)
Ball Butt Connector D28 (Set)

Gewicht [g]
Weight [g]

Teil-Nr.
Part #

150.0

099RV28KS02



SET ADAPTERPLATTE D28

SET ADAPTER PLATE D28

Ausführung	für Rundrohrprofile	Model	For tubular frame profiles
Beschreibung	zur Verbindung von Rundrohrprofilen mit Aluminiumprofilen Nut 8 oder Nut 10	Description	To connect tubular frame profiles with slot 8 or 10 aluminum profiles
Material	Adapterplatte: Aluminiumdruckguss Nutfixierung: Zinkdruckguss	Material	Adapter plates: Aluminum die-cast Centering piece: Zinc die-cast
Befestigung	mit Linsenkopfschrauben ISO 7380 - M8	Fastening	with pan-head-screw ISO 7380 - M8
Set	1 Adapterplatte, 2 Nutfixierungen für Nut 8 und Nut 10	Set	1 adapter plate, 2 locating pins for slot 8 and 10
Liefereinheit	10 Stück	Pack Quantity	10 pieces
Hinweis	passender Verbinder siehe Seite 770 und Seite 778 ff. * Schneidhülse zur Reduzierung des Kernlochs \varnothing 10,2 mm auf Gewindegröße M8 siehe Seite 500	Tip	Compatible connector see page 770 and page 778 et sq. * Cut bush for the reduction of the \varnothing 10.2 mm core hole to thread size M8 see page 500

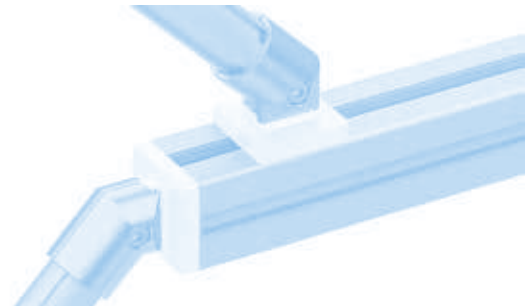
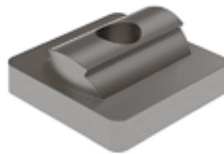
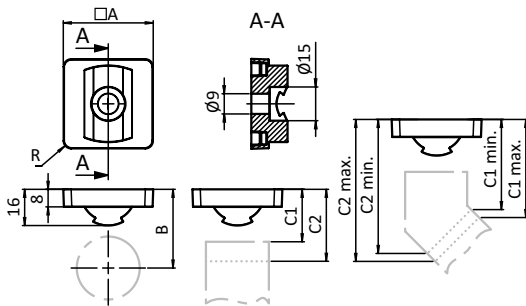

Set Adapterplatte D28 Set Adapter Plate D28	Verbinder Connector	A [mm]	B [mm]	C1 [mm]	C2 [mm]	N	R [mm]	Gewicht [g] Weight [g]	Teil-Nr. Part #
⚡ elektrostatisch entladend electrostatically discharging		40.0				8 / 10	4.0	29.0	099RVAP40S01
		45.0				8 / 10	3.0	33.0	* 099RVAP45S01
if mounted with bei Montage mit	099RV28PS01		59.0						
	099RV28180S01		47.0						
	099RV2890LS01			28.5	40.5				
	099RV28KS01			85.5	91.5				
	099RV2845S01			min. 23.0 max. 27.0	min. 43.0 max. 46.5				



T-VERBINDERPLATTE D28

T-CONNECTOR PLATE D28

<p>Ausführung für Rundrohrprofile</p> <p>Beschreibung zur rechtwinkligen Verbindung von einem Rundrohrprofil mit Aussendurchmesser \varnothing 28 mm mit einem Aluminiumprofil; Verschraubung im Kernloch M8 des Rundrohrprofils \varnothing 28mm, oder in der Gewindehülse D28 M8 für Rundrohrprofile \varnothing 28mm</p> <p>Material Stahl</p> <p>Oberfläche verzinkt</p> <p>Befestigung mit Senkkopfschrauben 1x M8 und 2x M6</p> <p>Liefereinheit 10 Stück</p> <p>Hinweis passende Gewindehülse D28 M8: 099RV28AS02</p>	<p>Model For tubular frame profiles</p> <p>Description To connect a tubular frame profile with \varnothing 28 mm outer diameter with an aluminum profile at right angles; Screw connetion to the core hole of the \varnothing 28mm profile or to the threaded sleeve for D28 M8 for \varnothing 28mm tubular profiles</p> <p>Material Steel</p> <p>Surface Zinc plated</p> <p>Fastening With countersunk screws 1x M8 and 2x M6</p> <p>Pack Quantity 10 pieces</p> <p>Tip Compatible threaded sleeve D28 M8: 099RV28AS02</p>
--	--

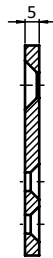
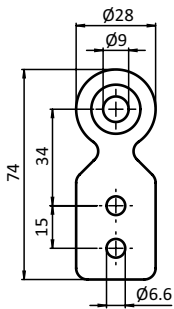

T-Verbinderplatte D28
T-Connector Plate D28

Gewicht [g]
Weight [g]

Teil-Nr.
Part #

52.3

093VAD28V

SET HALTEWINKEL 60 × 47 × 4, D28

SET MOUNTING BRACKET 60 × 47, D28

<p>Ausführung für Rundrohrprofile</p> <p>Beschreibung zur rechtwinkligen Verbindung eines Rundrohrprofils mit Außendurchmesser Ø 28 mm mit einem Aluminiumprofil Nut 10; Justierung mittels Langlöchern</p> <p>Material Stahl</p> <p>Set 1 Haltewinkel, 1 selbstformende Schraube S8 × 25 - Torx T40, 2 Hammerschrauben - Nut 10 - M8 × 20, 2 Flanschmuttern M8</p> <p>Liefereinheit 20 Stück</p>	<p>Model For tubular frame profiles</p> <p>Description To connect a tubular frame profile with Ø 28 mm outer diameter with a slot 10 aluminum profile; adjustable by slotted holes</p> <p>Material Steel</p> <p>Set 1 mounting bracket, 1 self-tapping screw S8 × 25 - Torx T40, 2 hammer head screws - Nut 10 - M8 × 20, 2 flange nuts M8</p> <p>Pack Quantity 20 pieces</p>
--	--

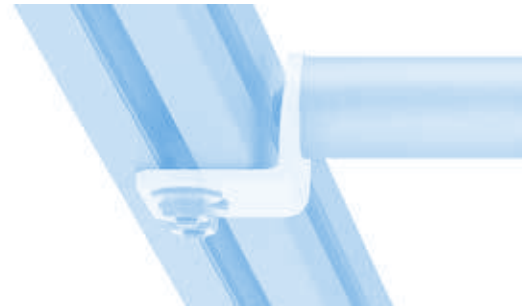
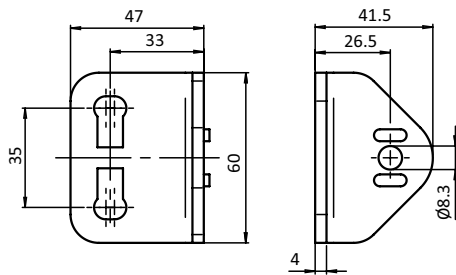

Set Haltewinkel 60 × 47 × 4, D28
Set Mounting Bracket 60 × 47, D28

Gewicht [g]
Weight [g]

Profil
Profile

Teil-Nr.
Part #

elektrostatisch entladend  electrostatically discharging	176.0	B	099RV28TWS01
---	-------	---	--------------



SET WINKELVERBINDER D28, 45°

SET ANGLE CONNECTOR D28, 45°

<p>Ausführung für Rundrohrprofil</p> <p>Beschreibung für eine 45°-Verbindung von zwei Rundrohrprofilen mit Außendurchmesser \varnothing 28 mm, mit Verdrehsicherung; komplett vormontiertes Set</p> <p>Material Verbinder: Aluminiumdruckguss Montageset: Stahl</p> <p>Set 2 Elemente für Winkelverbinder D28, 45°, 1 Schraube DIN 912 - M6 \times 25, 1 selbstsichernde Mutter ISO 10511 - M6</p> <p>Liefereinheit 10 Stück</p>	<p>Model For tubular frame profiles</p> <p>Description To connect two tubular frame profiles with \varnothing 28 mm outer diameter at 45°; with pre-centering; completely pre-assembled set</p> <p>Material Connector: Aluminum die-cast Assembly set: Steel</p> <p>Set 2 components for angle connector D28, 45°, 1 screw DIN 912 - M6 \times 25, 1 self-locking nut ISO 10511 - M6</p> <p>Pack Quantity 10 pieces</p>
---	--

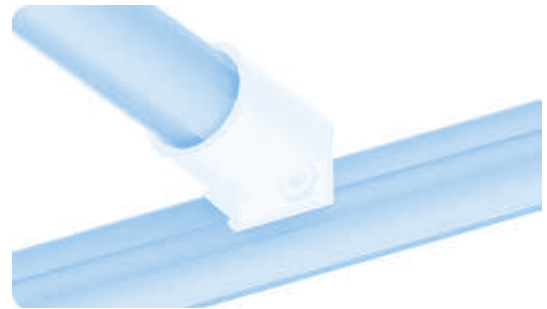
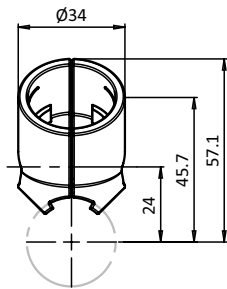
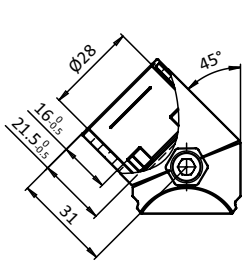

Set Winkelverbinder D28, 45°
Set Angle Connector D28, 45°

Gewicht [g]
Weight [g]

Teil-Nr.
Part #

elektrostatisch entladend electrostatically discharging

58.0

099RV2845S01

Rundrohrkomponenten *Tubular Frame Components*

Rundrohrverbinder *Tubular Frame Connectors*

Variable Verbinder *Variable Connectors*



SET KUGELVERBINDER D28

SET BALL CONNECTOR D28

<p>Ausführung für Rundrohrprofile</p> <p>Beschreibung zur variablen Verbindung von zwei Rundrohrprofilen mit Außendurchmesser \varnothing 28 mm, mit Verdrehsicherung; komplett vormontiertes Set</p> <p>Material Verbinder: Aluminiumdruckguss Montageset: Stahl</p> <p>Set 4 Elemente für Kugelverbinder D28, 2 Schrauben DIN 912 - M6 \times 25, 2 selbstsichernde Muttern ISO 10511 - M6</p> <p>Liefereinheit 10 Stück</p>	<p>Model For tubular frame profiles</p> <p>Description To connect two tubular frame profiles with \varnothing 28 mm outer diameter at variable angles, with pre-centering; completely pre-assembled set</p> <p>Material Connector: Aluminum die-cast Assembly set: Steel</p> <p>Set 4 components for ball connector D28, 2 screws DIN 912 - M6 \times 25, 2 self-locking nuts ISO 10511 - M6</p> <p>Pack Quantity 10 pieces</p>
---	--

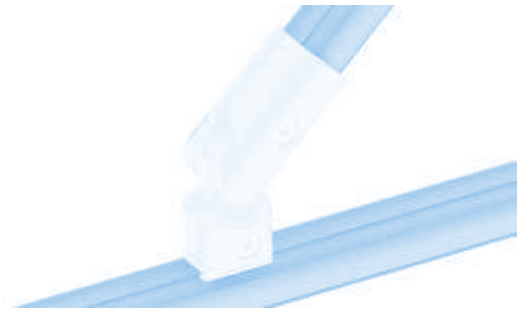
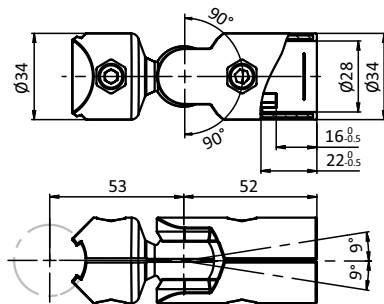

Set Kugelverbinder D28
Set Ball Connector D28

Gewicht [g]
Weight [g]

Teil-Nr.
Part #

elektrostatisch entladend electrostatically discharging

145.0

099RV28KS01

SET KREUZVERBINDER D28

SET CROSS CONNECTOR D28

<p>Ausführung für Rundrohrprofile</p> <p>Beschreibung zur Kreuzverbindung von zwei Rundrohrprofilen mit Außendurchmesser Ø 28 mm, mit Verdrehsicherung; komplett vormontiertes Set</p> <p>Material Verbinder: Aluminiumdruckguss Montageset: Stahl</p> <p>Set 2 Elemente für Kreuzverbinder D28, 1 Schraube ISO 4762 - M6 × 30, 1 selbstsichernde Mutter ISO 10511 - M6</p> <p>Liefereinheit 10 Stück</p>	<p>Model For tubular frame profiles</p> <p>Description To cross connect two tubular frame profiles with Ø 28 mm outer diameter; completely pre-assembled set</p> <p>Material Connector: Aluminum die-cast Assembly set: Steel</p> <p>Set 2 components for cross connector D28, 1 screw ISO 4762 - M6 × 30, 1 self-locking nut ISO 10511 - M6</p> <p>Pack Quantity 10 pieces</p>
--	--

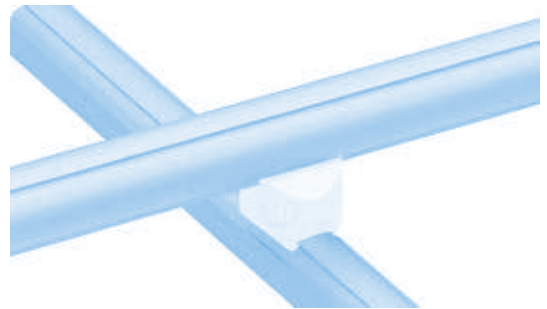
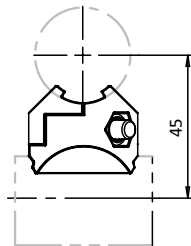
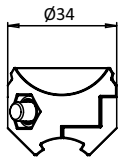

Set Kreuzverbinder D28
Set Cross Connector D28

Gewicht [g]
Weight [g]

Teil-Nr.
Part #

elektrostatisch entladend  electrostatically discharging

50.0

099RV28XS01

SET PARALLELVORBINDER D28

SET PARALLEL CONNECTOR D28

<p>Ausführung für Rundrohrprofil</p> <p>Beschreibung zur parallelen Verbindung von zwei Rundrohrprofilen mit Außendurchmesser Ø 28 mm; mit Verdrehsicherung; komplett vormontiertes Set</p> <p>Material Verbinder: Aluminiumdruckguss Montageset: Stahl</p> <p>Set 2 Elemente für Parallelverbinder D28, 1 Schraube DIN 912 - M6 × 25, 1 selbstsichernde Mutter ISO 10511 - M6</p> <p>Liefereinheit 10 Stück</p>	<p>Model For tubular frame profiles</p> <p>Description To parallelly connect two tubular frame profiles with Ø 28 mm outer diameter; with pre-centering; completely pre-assembled set</p> <p>Material Connector: Aluminum die-cast Assembly set: Steel</p> <p>Set 2 components for parallel connector D28, 1 screw DIN 912 - M6 × 25, 1 self-locking nut ISO 10511 - M6</p> <p>Pack Quantity 10 pieces</p>
--	--



Set Parallelverbinder D28
 Set Parallel Connector D28

Gewicht [g]
 Weight [g]

Teil-Nr.
 Part #

elektrostatisch entladend  electrostatically discharging

62.0

099RV28PS01



SET PARALLELKLEMME D28

SET PARALLEL CLAMP D28

<p>Ausführung für Rundrohrprofil</p> <p>Beschreibung zur parallelen Verbindung von einem Rundrohr oder Rundrohrprofil mit einem Rundrohrprofil mit Außendurchmesser \varnothing 28 mm, mit Verdrehsicherung; komplett vormontiertes Set</p> <p>Material Verbinder: Aluminiumdruckguss Montageset: Stahl</p> <p>Set 2 Elemente für Parallelklemme D28, 1 Schraube DIN 912 - M6 \times 25, 1 selbstsichernde Mutter ISO 10511 - M6</p> <p>Liefereinheit 10 Stück</p>	<p>Model For tubular frame profiles</p> <p>Description To parallelly connect a tube or a tubular frame profile to a tubular frame profile with \varnothing 28 mm outer diameter; with pre-centering; completely pre-assembled set</p> <p>Material Connector: Aluminum die-cast Assembly set: Steel</p> <p>Set 2 components for parallel clamp D28, 1 screw DIN 912 - M6 \times 25, 1 self-locking nut ISO 10511 - M6</p> <p>Pack Quantity 10 pieces</p>
---	--

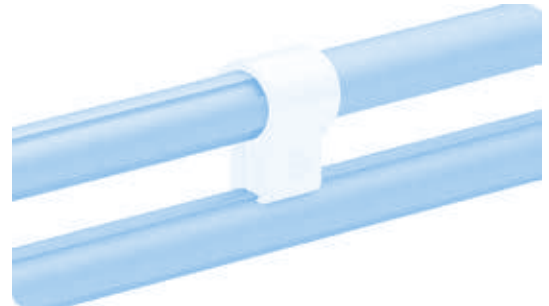
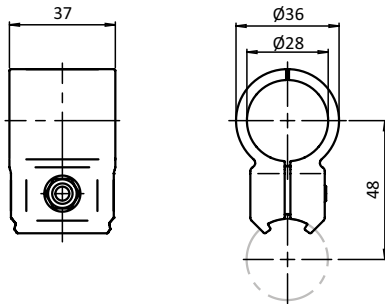

Set Parallelverbinder D28
 Set Parallel Clamp D28

Gewicht [g]
 Weight [g]

Teil-Nr.
 Part #

elektrostatisch entladend electrostatically discharging

80.3

099RV28180S01



SET BEFESTIGUNGSKLEMME D28

SET MOUNTING CLAMP D28

<p>Ausführung für Rundrohrprofile</p> <p>Beschreibung zur seitlichen Befestigung eines Rundrohrprofils mit Außendurchmesser $\varnothing 28$ mm an einem Aluminiumprofil, Lochabstand kompatibel zu Ergoswiss® Hubzylindern</p> <p>Material Befestigungsklemme: Zinkdruckguss Montageset: Stahl</p> <p>Set 2 Elemente für Befestigungsklemme D28, 2 Schrauben DIN 912 - M5 \times 16, 2 Schrauben DIN 912 - M5 \times 10, 2 Muttern DIN 934 - M5</p> <p>Liefereinheit 10 Stück</p>	<p>Model For tubular frame profiles</p> <p>Description To laterally connect a tubular frame profile with $\varnothing 28$ mm outer diameter to an aluminum profile, hole spacing compatible with Ergoswiss® lift cylinders</p> <p>Material Connector: Zinc die-cast Assembly set: Steel</p> <p>Set 2 components for mounting clamp D28, 2 screws DIN 912 - M5 \times 16, 2 screws DIN 912 - M5 \times 10, 2 nuts DIN 934 - M5</p> <p>Pack Quantity 10 pieces</p>
--	--

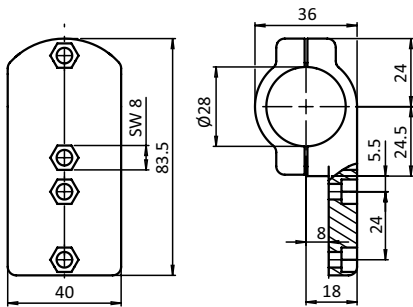

Set Befestigungsklemme D28
 Set Mounting Clamp D28

Gewicht [g]
 Weight [g]

Teil-Nr.
 Part #

212.0

099RV28H

EINHÄNGEPLATTE D28 / D30

SUSPENSION PLATE D28 / D30

<p>Ausführung für Rundrohrprofile</p> <p>Beschreibung zur Befestigung von Greifschalen, Greif- und Schalenbehältern an horizontalen oder vertikalen Rundrohrprofilen mit Aussendurchmesser \varnothing 28 mm oder \varnothing 30 mm</p> <p>Material Einhängenplatte: Kunststoff PA, glasvaserverstärkt Befestigungsmaterial: Stahl</p> <p>Farbe Einhängenplatte: schwarz</p> <p>Oberfläche Befestigungsmaterial: verzinkt</p> <p>Liefereinheit 10 Stück</p> <p>Hinweis passende Greifschalen siehe Seite 568; passende Greifbehälter siehe Seite 570; passende Schalenbehälter siehe Seite 571</p>	<p>Model For tubular frame profiles</p> <p>Description To fix grab trays, grab container and tray container to horizontal or vertical tubular frame profiles with \varnothing 28 mm or \varnothing 30 mm outer diameter</p> <p>Material Suspension plate: Plastics PA, glass fiber reinforced Assembly material: Steel</p> <p>Color Suspension plate: Black</p> <p>Surface Assembly material: Zinc plated</p> <p>Pack Quantity 10 pieces</p> <p>Tip Compatible grab tray see page 568; compatible grab container see page 570; compatible tray container see page 571</p>
---	--

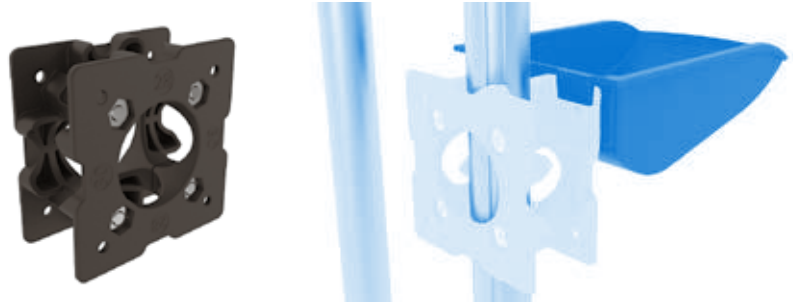
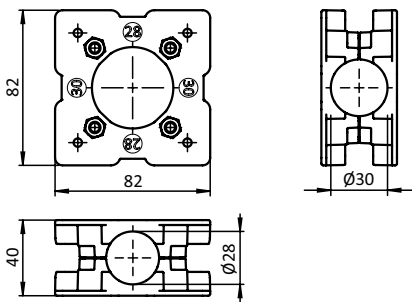

Einhängenplatte D28 / D30
Suspension Plate D28 / D30

Gewicht [g]
Weight [g]

Teil-Nr.
Part #

113.0

061MA291D



BESCHRIFTUNGSClip D28

LABEL CLIP D28

Ausführung	für Rundrohrprofil	Model	For tubular frame profiles
Beschreibung	zum Beschriften von Rundrohrprofilen mit Außendurchmesser Ø 28 mm; für Etikettenhöhe 38 mm	Description	For labelling on tubular frame profiles with Ø 28 mm outer diameter; for labels with 38 mm height
Material	Kunststoff Hart-PVC	Material	Plastic hard PVC
Befestigung	mit rückseitigem Selbstklebestreifen	Fastening	Self-adhesive strip on the backside
Liefereinheit	20 Stück (à 120 mm) oder 20 Meter (10 Stück á 2 m)	Pack Quantity	20 pieces (at 120 mm) or 20 meters (10 pieces at 2 m)
Hinweis	*Bitte beachten: Sie bestellen in Meter!	Tip	*Please note: You are ordering in meters!

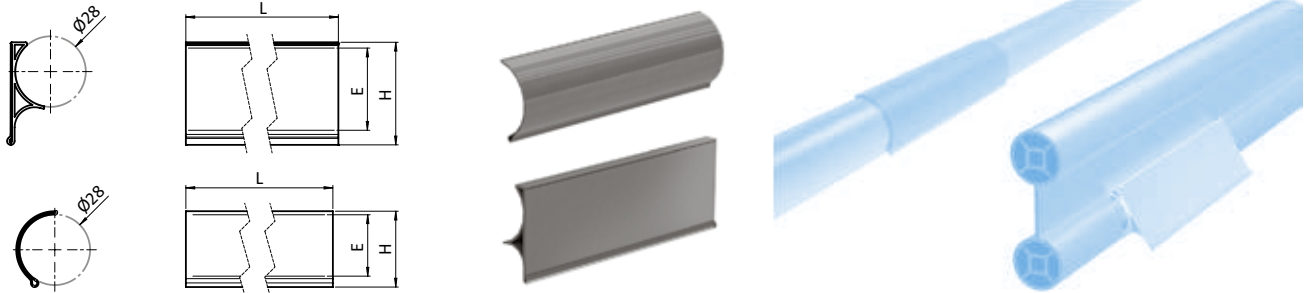

Beschriftungsclip D28 Label Clip D28	E [mm]	H [mm]	L [mm]	Farbe	für Profil For Profile	Gewicht [g] Weight [g]	Profil Profile	Teil-Nr. Part #
gerade Schriftfläche Straight labeling surface	38	41	120	grau + transparent Gray + transparent	D28	15.0	B	093LC38D28S01.120
	38	41	*2000	grau + transparent Gray + transparent	D28	270.0	B	093LC38D28S01.2000
gerundete Schriftfläche Curved labeling surface	38	40	120	transparent Transparent	D28	4.0	B	093LCT38D28.120
	38	40	*2000	transparent Transparent	D28	72.0	B	093LCT38D28.2000



VARIOBLOCK AL D28

VARIO BLOCK AL D28

<p>Ausführung für Rundrohrprofile</p> <p>Beschreibung zur stabilen Befestigung von Flächenelementen an Rundrohrprofilen mit Außendurchmesser Ø 28 mm; ⚡ elektrostatisch entladend</p> <p>Material Aluminium</p> <p>Spannbreite Flächenelemente von 6 - 17 mm</p> <p>Set 1 Varioblock AL - 2-teilig, 1 Schraube DIN 912 - M6 × 30, 2 Schrauben DIN 912 - M6 × 22, 2 Vierkantmuttern DIN 557 - M6</p> <p>Liefereinheit 10 Stück</p> <p>Extras weitere Oberflächen, weitere Farben auf Anfrage</p> <p>Hinweis passende Gleitleiste D28 siehe Seite 767</p>	<p>Model For tubular frame profiles</p> <p>Description To attach panels firmly to tubular frame profiles with Ø 28 mm outer diameter, ⚡ electrostatically discharging</p> <p>Material Aluminum</p> <p>Fixation Span Panel units with a thickness of 6 - 17 mm</p> <p>Set 1 vario block AL - 2-part, 1 screw DIN 912 - M6 × 30, 2 screws DIN 912 - M6 × 22, 2 square nuts DIN 557 - M6</p> <p>Pack Quantity 10 pieces</p> <p>Specials Other surfaces, other colors on request</p> <p>Tip Compatible slide rail D28 see page 767</p>
---	--

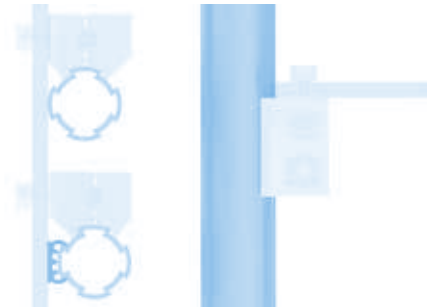
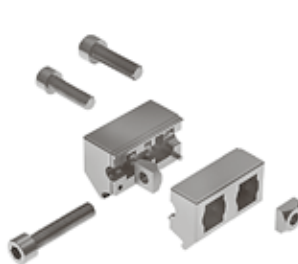
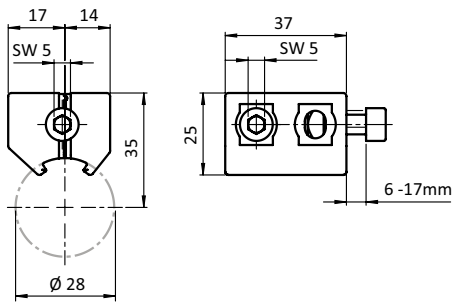

Varioblock AL D28 Vario Block AL D28	Maße L × B × H [mm] Dimensions L × B × H [mm]	Gewicht [g] Weight [g]	Profil Profile	Teil-Nr. Part #
	37.0 × 31.1 × 25.0	63.5	B	094AD28



VARIOBLOCK D28 (SET)

VARIO BLOCK D28 (SET)

<p>Ausführung für Rundrohrprofile</p> <p>Beschreibung zur sicheren Befestigung von Flächenelementen an einem Rundrohrprofil mit Außendurchmesser \varnothing 28 mm; optional schraubenlose Befestigung mit Rastklemme</p> <p>Material Block: Kunststoff PA, kohlefaserverstärkt Rastklemme: Kunststoff PC Schrauben und Mutter: Stahl</p> <p>Farbe Block: schwarz Rastklemme: glasklar farblos</p> <p>Spannbreite mit Rastklemme von 0 - 8 mm</p> <p>Set 1 Varioblock - 2-teilig, 1 Schraube DIN 7981 - 4,2 x 9,5, 1 Schraube DIN 912 - M6 x 16, 1 Vierkantmutter DIN 557 - M6</p> <p>Liefereinheit 100 Stück</p>	<p>Model For tubular frame profiles</p> <p>Description To attach panels safely to tubular frame profiles with \varnothing 28 mm outer diameter; optional screwless mounting with clip clamp</p> <p>Material Block: Plastic PA, carbon fiber reinforced Clip clamp: Plastic PC Screws and Nut: Steel</p> <p>Color Block: Black Clip clamp: Transparent colorless</p> <p>Fixation Span With Clip clamp from 0 to 8 mm</p> <p>Set 1 vario block AL - 2-part, 1 screw DIN 7981 - 4.2 x 9.5, 2 screws DIN 912 - M6 x 16, 1 square nut DIN 557 - M6</p> <p>Pack Quantity 100 pieces</p>
---	---



Varioblock D28 (Set) Vario Block D28 (Set)	Gewicht [g] Weight [g]	Profil Profile	Teil-Nr. Part #
	20.0	B	094524M6
Rastklemme <i>Clip clamp</i>	2.8		09452RA20



TECHNISCHER ANHANG *TECHNICAL ANNEX*

Bodenelemente <i>Floor Elements</i>	1
Scharniere <i>Hinges</i>	2
Nutmuttern und -schrauben <i>T-Nuts and T-Bolts</i>	3
Verbindungstechnik <i>Connecting Systems</i>	4
Griffe und Verschlüsse <i>Handles and Latches</i>	5
Arbeitsplatzkomponenten <i>Components for Work Stations</i>	6
Gleiter und Rollen <i>Sliders and Rollers</i>	7
Fördertechnik <i>Conveyors</i>	8
Schutz- und Trennwandelemente <i>Enclosures, Guards, Partitions</i>	9
Flächenbefestigungen <i>Panel Fasteners</i>	10
Abdeckelemente <i>Cover Elements</i>	11
Kabelführungen <i>Cable Management</i>	12
Diverse Komponenten <i>Miscellaneous Components</i>	13
Rundrohrkomponenten <i>Tubular Frame Components</i>	14



MABTOLERANZEN

(Auszug aus der FATH-Norm 0055)

Toleranzen von verschiedenen Materialien

Die Grenzabmaße sorgen für gleichbleibende Qualität (Funktion, Aussehen...) der Produkte bei FATH. Sollten für Produkte engere oder weitere Toleranzen benötigt werden, sind diese direkt in der Zeichnung eingetragen.

1.1 Toleranzen von Metallbauteilen (Stahl, Aluminium, Zink...)

Soweit nicht anders angegeben sind Metallbauteile nach DIN ISO 2768 – mK– E toleriert.

1.1.1 Grenzmaße für Längenmaße, außer für gebrochene Kanten

Kleinere oder größere Grenzmaße sind in der Zeichnung direkt toleriert. Wenn nicht, gilt die Toleranz des nächst gelegenen Maßbereiches.

Grenzmaße für Längenmaße
Deviation Limits for Linear Measures

Nennmaßbereich [mm] <i>Nominal dimension range [mm]</i>	Grenzabmaße [mm] <i>Deviation limits [mm]</i>
0.5 ≤ 6	± 0.1
> 6 ≤ 30	± 0.2
> 30 ≤ 120	± 0.3
> 120 ≤ 400	± 0.5

1.1.2 Grenzabmaße für gebrochene Kanten

(Rundungshalbmesser und Fasenhöhen)
Kleinere Grenzmaße sind in der Zeichnung direkt toleriert. Wenn nicht, gilt die Toleranz nächst gelegenen Maßbereiches.

Grenzabmaße für Nennmaßbereich
Deviation Limits for Nominal Dimension Range

Nennmaßbereich [mm] <i>Nominal dimension range [mm]</i>	Grenzabmaße [mm] <i>Deviation limits [mm]</i>
0.5 ≤ 3	± 0.2
> 3 ≤ 6	± 0.5
> 6	± 1

1.1.3 Grenzabmaße für Winkelmaße

(Rundungshalbmesser und Fasenhöhen)
Kleinere oder größere Grenzmaße sind in der Zeichnung direkt toleriert. Wenn nicht, gilt die Toleranz des nächst gelegenen Maßbereiches.

Grenzabmaße für Winkelmaße
Deviation Limits for Angular Dimensions

Nennmaßbereich (kürzerer Schenkel) [mm] <i>Nominal dimension range (shorter arm) [mm]</i>	Grenzabmaße <i>Deviation limits</i>
≤ 10	± 1°
> 10 ≤ 50	± 0°30'
> 50 ≤ 120	± 0°20'
> 120 ≤ 400	± 0°10'

DIMENSIONAL TOLERANCES

(Excerpt from FATH norm 0055)

Tolerances for Different Materials

Deviation limits ensures consistent quality (functionality, appearance...) of all FATH products. In case closer or wider tolerances are intended, these are indicated in the drawing.

1.1 Tolerances of Metal Parts

If not indicated otherwise, metal parts have tolerances according to DIN ISO 2768 – mK– E.

1.1.1 Deviation Limits for Linear Measures, Except Chamfered Edges

Closer or wider deviation limits are indicated in the drawing. If not, tolerances of the nearest dimension range apply.

1.1.2 Deviation Limits for Chamfered Edges

*(External radii and chamfer heights)
Closer deviation limits are indicated in the drawing. If not, tolerances of the nearest dimension range apply.*

1.1.3 Deviation Limits for Angular Dimensions

*(External radii and chamfer heights)
Closer or wider deviation limits are indicated in the drawing. If not, tolerances of the nearest dimension range apply.*

MABTOLERANZEN
 (Auszug aus der FATH-Norm 0055)

1.2 Toleranzen von Kunststoffbauteilen

Soweit nicht anders angegeben sind Kunststoffbauteile in Anlehnung an DIN 16742 – TG2 toleriert.

1.2.1 Kunststoff-Formteiltoleranzen als symmetrische Grenzmaße für Größenmaße

Kleinere oder größere Grenzmaße sind in der Zeichnung direkt toleriert. Wenn nicht, gilt die Toleranz des nächst gelegenen Maßbereiches.

DIMENSIONAL TOLERANCES
 (Excerpt from FATH norm 0055)

1.2 Tolerances of Plastic Parts

If not indicated otherwise, plastic parts have tolerances following DIN 16742 – TG2.

1.2.1 Plastic Part Tolerances as Symmetric Deviation Limits for Dimensional Measures

Closer or wider deviation limits are indicated in the drawing. If not, tolerances of the nearest dimension range apply.

Grenzmaße für Längenmaße <i>Deviation Limits for Linear Measures</i>	Nennmaßbereich [mm] <i>Nominal dimension range [mm]</i>	Grenzmaße [mm] <i>Deviation limits [mm]</i>
	1 ≤ 3	± 0.12
	> 3 ≤ 6	± 0.18
	> 6 ≤ 10	± 0.22
	> 10 ≤ 18	± 0.26
	> 18 ≤ 30	± 0.31
	> 30 ≤ 50	± 0.37
	> 50 ≤ 80	± 0.57
	> 80 ≤ 120	± 0.80
	>120 ≤ 180	± 0.93
	> 180 ≤ 250	± 1.05

1.2.2 Kunststoff-Formteiltoleranzen für Positionstoleranzen

Kleinere oder größere Grenzmaße sind in der Zeichnung direkt toleriert. Wenn nicht, gilt die Toleranz des nächst gelegenen Maßbereiches.

1.2.2 Plastic Part Tolerances for Positioning Tolerances

Closer or wider deviation limits are indicated in the drawing. If not, tolerances of the nearest dimension range apply.

Kunststoff-Formteiltoleranzen für Positionstoleranzen <i>Plastic Part Tolerances for Positioning Tolerances</i>	Nennmaßbereich [mm] <i>Nominal dimension range [mm]</i>	Durchmesser der zylindrischen Toleranzzonen [mm] <i>Diameter of the cylindrical tolerance areas [mm]</i>
	1 ≤ 3	∅ 0.34
	> 3 ≤ 6	∅ 0.51
	> 6 ≤ 10	∅ 0.62
	> 10 ≤ 18	∅ 0.74
	> 18 ≤ 30	∅ 0.88
	> 30 ≤ 50	∅ 1.1
	> 50 ≤ 80	∅ 1.6
	> 80 ≤ 120	∅ 2.3
	>120 ≤ 180	∅ 2.6
	> 180 ≤ 250	∅ 3.0

MABTOLERANZEN

(Auszug aus der FATH-Norm 0055)

1.3 Toleranzen von in dieser Norm nicht aufgeführten

Werkstoffen

Für hier nicht aufgeführte Werkstoffe gelten die Allgemeintoleranzen aus Abschnitt 1.1.

Abweichende Toleranzen sind direkt in der Zeichnung angegeben.

1.4 Allgemeine Informationen zu Toleranzen bei FATH

(...)

1.4.2 Maß-, Form-, Lage und Oberflächentoleranzen sind jeweils unabhängig voneinander zu betrachten (Unabhängigkeitsprinzip nach EN ISO 8015)

1.4.3 CAD-Datensätze und Zeichnungen entsprechen, ausser bei asymmetrischen Toleranzangaben, den Nennmaßgeometrien

1.4.4 Alle Maße mit Allgemeintoleranzen werden im Prüfprotokoll nichtberücksichtigt.

Im Kunststoffbereich ist in der DIN EN ISO 291 als Normklima $23\text{ °C} \pm 2\text{ K}$ und $50\% \pm 10\%$ relative Luftfeuchte festgelegt.

Im Schriftfeld ist der Hinweis:

»Tolerierung ISO 8015 (AD) – DIN EN ISO 291:2008-08«
angegeben.

1.4.5 Zur Messung von Radien müssen mindestens 90° des Kreissegmentes als messbare Kontur vorhanden sein.

1.4.6 Positionstoleranzen sind keine Allgemeintoleranzen. Wenn es die Funktion erfordert, sind sie direkt in Zeichnungen eingetragen und müssen vermessen werden.

1.5 Zurückweisung

»Wenn nicht anders festgelegt, dürfen Werkstücke, bei denen die Allgemeintoleranzen nicht eingehalten sind, nicht automatisch zurückgewiesen werden, wenn ihre Funktion nicht beeinträchtigt ist. Oft erlaubt die Funktion eine größere Toleranz als die Allgemeintoleranz. Deshalb wird die Funktion eines Teiles nicht immer beeinträchtigt, wenn die Allgemeintoleranzen eines beliebigen Formelementes eines Werkstückes (gelegentlich) nicht eingehalten ist. Das Überschreiten der Grenzen der Allgemeintoleranzen soll nur dann zu einer Zurückweisung des Werkstückes führen, wenn die Funktion beeinträchtigt ist.«

(DIN ISO 2768 – Ausgabe 04.91)

DIMENSIONAL TOLERANCES

(Excerpt from FATH norm 0055)

1.3 Tolerances for Materials Not Specified in this Standard

For materials not specified in this standard the general tolerances from section 1.1 apply.

Deviant tolerances are declared in the drawing.

1.4 General Information about Tolerances at FATH

(...)

1.4.2 Tolerances on dimensions and shapes as well as on surfaces are to regard each separately (Principle of Independence according to EN ISO 8015)

1.4.3 CAD data sets and drawings, except for asymmetric tolerance specifications, comply with the nominal geometry dimensions.

1.4.4 All dimensions with general tolerances are excluded from the test report.

For plastic parts, DIN EN ISO 291 defines a standard climate for measuring: $23\text{ °C} \pm 2\text{ K}$ und $50\% \pm 10\%$ relative air humidity.

In the title block:

“Tolerances according to ISO 8015 (AD) – DIN EN ISO 291:2008-08“
is indicated.

1.4.5 For the measurement of radii, 90° or more of the circle segment has to be accessible for measurement.

1.4.6 Positional tolerances are no general tolerances. If functionality requires so, these are indicated directly in the drawing and have to be measured.

1.5 Rejection

“Unless otherwise stated, workpieces exceeding the general tolerance shall not lead to automatic rejection provided that the ability of the workpiece to function is not impaired. The tolerance the function allows is often greater than the general tolerance. The function of the part is, therefore, not always impaired when the general tolerance is (occasionally) exceeded at any feature of the workpiece. Exceeding the general tolerance should lead to a rejection of the workpiece only if the function is impaired.”

(DIN ISO 2768 – issue 04.91)



FARBEN

(Auszug aus der FATH-Norm 0072)

1. Allgemeines

Farben werden bei FATH nach RAL definiert. Um nicht eine Vielzahl an Farbkarten (Lacke, Kunststoffe usw.) verwenden zu müssen, findet die »RAL K5 classic« Farbkarte bei FATH Verwendung. Auf Zeichnungen dürfen Farben ausschließlich mit RAL-Farbnummer angegeben werden.

COLORS

(Excerpt from FATH norm 0072)

1. General Information

Colors are defined in accordance with RAL at FATH. To avoid the usage of many different color maps (lacquers, plastics etc.), the "RAL K5 classic" map is generally used at FATH. On drawings, colors are to be indicated with RAL numbers exclusively.

FATH Farbtabelle FATH Color Map	RAL-Farbname RAL color name	RAL-Nummer RAL number	Zeichnungsangabe Indication on drawing	Verwendung, Hinweise Usage, notes
	Signalgelb <i>Signal yellow</i>	1003	RAL 1003 Signal yellow according to FATH Standard 0072	FATH Standard
	Narzissengelb <i>Daffodil yellow</i>	1007	RAL 1007 Daffodil yellow according to FATH Standard 0072	
	Zinkgelb <i>Zinc yellow</i>	1018	RAL 1018 Zinc yellow according to FATH Standard 0072	
	Verkehrsgelb <i>Traffic yellow</i>	1023	RAL 1023 Traffic yellow according to FATH Standard 0072	
	Pastellorange <i>Pastel orange</i>	2003	RAL 2003 Pastel orange according to FATH Standard 0072	
	Reinorange <i>Pure orange</i>	2004	RAL 2004 Pure orange according to FATH Standard 0072	
	Feuerrot <i>Flame red</i>	3000	RAL 3000 Flame red according to FATH Standard 0072	
	Karminrot <i>Carmine red</i>	3002	RAL 3002 Carmine red according FATH Standard 0072	
	Rubinrot <i>Ruby red</i>	3003	RAL 3003 Ruby red according to FATH Standard 0072	
	Purpurrot <i>Purple red</i>	3004	RAL 3004 Purple red according to FATH Standard 0072	
	Verkehrsrot <i>Traffic red</i>	3020	RAL 3020 Traffic red according to FATH Standard 0072	FATH Standard
	Violettblau <i>Violet blue</i>	5000	RAL 5000 Violet blue according to FATH Standard 0072	
	Signalblau <i>Signal blue</i>	5005	RAL 5005 Signal blue according to FATH Standard 0072	
	Graublau <i>Gray blue</i>	5008	RAL 5008 Gray blue according to FATH Standard 0072	
	Enzianblau <i>Gentian blue</i>	5010	RAL 5010 Gentian blue according to FATH Standard 0072	
	Taubenblau <i>Pigeon blue</i>	5014	RAL 5014 Pigeon blue according to FATH Standard 0072	
	Verkehrsblau <i>Traffic blue</i>	5017	RAL 5017 Traffic blue according to FATH Standard 0072	
	Wasserblau <i>Water blue</i>	5021	RAL 5021 Water blue according to FATH Standard 0072	
	Nachtblau <i>Night blue</i>	5022	RAL 5022 Night blue according to FATH Standard 0072	
	Türkisgrün <i>Turquoise green</i>	6016	RAL 6016 Turquoise green according to FATH Standard 0072	
	Verkehrsgrün <i>Traffic green</i>	6024	RAL 6024 Traffic green according to FATH Standard 0072	
	Signalgrün <i>Signal green</i>	6032	RAL 6032 Signal green according to FATH Standard 0072	FATH Standard
	Fehgrau <i>Squirrel gray</i>	7000	RAL 7000 Squirrel gray according to FATH Standard 0072	
	Silbergrau <i>Silver gray</i>	7001	RAL 7001 Silver gray according to FATH Standard 0072	
	Signalgrau <i>Signal gray</i>	7004	RAL 7004 Signal gray according to FATH Standard 0072	B
	Eisengrau <i>Iron gray</i>	7011	RAL 7011 Iron gray according to FATH Standard 0072	
	Basaltgrau <i>Basalt gray</i>	7012	RAL 7012 Basalt gray according to FATH Standard 0072	
	Anthrazitgrau <i>Anthracite gray</i>	7016	RAL 7016 Anthracite gray according to FATH Standard 0072	
	Steingrau <i>Stone gray</i>	7030	RAL 7030 Stone gray according to FATH Standard 0072	
	Lichtgrau <i>Light gray</i>	7035	RAL 7035 Light gray according to FATH Standard 0072	
	Staubgrau <i>Dusty gray</i>	7037	RAL 7037 Dusty gray according to FATH Standard 0072	
	Fenstergrau <i>Window gray</i>	7040	RAL 7040 Window gray according to FATH Standard 0072	
	Verkehrsgrau A <i>Traffic gray A</i>	7042	RAL 7042 Traffic gray A according to FATH Standard 0072	FATH Standard / I
	Verkehrsgrau B <i>Traffic gray B</i>	7043	RAL 7043 Traffic gray B according to FATH Standard 0072	
	Graubraun <i>Gray brown</i>	8019	RAL 8019 Gray brown according to FATH Standard 0072	
	Cremeweiss <i>Cream</i>	9001	RAL 9001 Cream according to FATH Standard 0072	
	Grauweiss <i>Gray white</i>	9002	RAL 9002 Gray white according to FATH Standard 0072	
	Signalweiss <i>Signal white</i>	9003	RAL 9003 Signal white according to FATH Standard 0072	
	Tiefschwarz <i>Jet black</i>	9005	RAL 9005 Jet black according to FATH Standard 0072	
	Weißaluminium <i>White aluminium</i>	9006	RAL 9006 White aluminium According to FATH Standard 0072	
	Graualuminium <i>Gray aluminium</i>	9007	RAL 9007 Gray aluminium according to FATH Standard 0072	
	Reinweiss <i>Pure white</i>	9010	RAL 9010 Pure white according to FATH Standard 0072	
	Verkehrsweiss <i>Traffic white</i>	9016	RAL 9016 Traffic white according to FATH Standard 0072	
	Perhellgrau <i>Pearl light gray</i>	9022	RAL 9022 Pearl light gray according to FATH Standard 0072	



OBERFLÄCHENANGABEN BEI FATH
(Auszug aus der FATH-Norm 0073)

Generelle Vorgaben für Oberflächen

Maßangaben auf Produktzeichnungen beziehen sich auf das Fertigprodukt. Die Schicktdicken sind bei der Fertigung zu berücksichtigen.

1.1 Pulverbeschichtungen

Farbe <i>Color</i>	Glanzgrad <i>Gloss level</i>	Ebenheit <i>Flatness</i>	mögliches Pulver <i>Possible powder</i>	Angabe auf Zeichnung <i>Indication on drawing</i>
schwarz <i>Black</i>	matt <i>Matt</i>	glatt <i>Flat</i>	AKZO NOBEL Interpon Autobody MN206D	Powder coated black according to FATH 0073
metallisch <i>Metallic</i>	matt <i>Matt</i>	glatt <i>Flat</i>	OXYPLAST PE82 ANO-LOOK	Powder coated metallic according to FATH 0073

1.2 Galvanisch verzinken

Verzinkungsangaben nach DIN 50960 ff

Norm <i>Standard</i>	Grundwerkstoff <i>Basic material</i>	Überzug <i>Coating</i>	Chromatierung <i>Chromating</i>	ergänzende Angabe <i>Additional information</i>
DIN 50961	Fe = Stahl, Eisen <i>Steel, iron</i>	Zn = Zink <i>Zinc</i>	X = beliebig <i>Arbitrary</i>	mt = matt <i>Matt</i>
	Zn = Zink <i>Zinc</i>	Cd = Cadmium <i>Cadmium</i>	A = farblos <i>Colorless</i>	bk = blank <i>Plain</i>
	Cu = Kupfer <i>Copper</i>	Ni = Nickel <i>Nickel</i>	B = blau <i>Blue</i>	gl = glänzend <i>Glossy</i>
	Al = Aluminium <i>Aluminum</i>	Cu = Kupfer <i>Copper</i>	C = gelb <i>Yellow</i>	hgl = hochglänzend <i>Highly glossy</i>
		Cr = Chrom <i>Chrome</i>	D = oliv <i>Olive green</i>	
		Sn = Zinn <i>Tin</i>	E = grün <i>Green</i>	
		Ag = Silber <i>Silver</i>	F = schwarz <i>Black</i>	
		Au = Gold <i>Gold</i>		

DIN 50961

– Galvanische Überzüge – Zinküberzüge auf Eisenwerkstoffen

DIN 50962

– Galvanische Überzüge – Chromatierte Zinklegierungsüberzüge auf Eisenwerkstoffen

DIN 50965

– Galvanische Überzüge – Zinnüberzüge auf Eisen- und Kupferwerkstoffen

Beispiel: Angabe auf der Zeichnung

DIN 50961 – Fe/Zn 5 B gl according to FATH 0073

1.2.1 Zinklamellenbeschichtung

Beschichtung nach DIN EN ISO 10683 für Verbindungselemente.

SURFACE SPECIFICATIONS AT FATH
(Excerpt from FATH norm 0073)

General Specifications for Surfaces

Dimensions on product drawings relate to the finished product. Coating thicknesses must be taken into consideration for production.

1.1 Powder Coatings

1.2 Galvanic Zinc Coating

Galvanizing declaration according to DIN 50960 et sq.

DIN 50961

– Galvanic coatings – Zinc coatings on iron or steel

DIN 50962

– Galvanic coatings – chromated coatings of zinc alloys on iron and steel

DIN 50965

– Galvanic coatings – Tin-coatings on iron steel and on copper and copper alloys

Example: Indication on drawing

1.2.1 Zinc Flake Coating

Coating according to DIN EN ISO 10683 for fasteners.



OBERFLÄCHENANGABEN BEI FATH
(Auszug aus der FATH-Norm 0073)

1.3 Eloxieren

Die DIN 17611 regelt die Oberflächenbeschaffenheit von eloxierten Teilen. Die Bezeichnung setzt sich wie folgt zusammen:

Bezeichnung 1 <i>Designation 1</i>	Prozess <i>Processing</i>
E0	entfetten und desoxidieren <i>Degrease and deoxidize</i>
E1	schleifen <i>Grind</i>
E2	bürsten <i>Brush</i>
E3	polieren <i>Polish</i>
E4	schleifen und bürsten <i>Grind and brush</i>
E5	schleifen und polieren <i>Grind and polish</i>
E6	beizen <i>Pickling</i>
E7	Chemisches oder elektrochemisches Glänzen <i>Chemical or electrochemical polish</i>
E8	Polieren und chemisches oderelektrochemisches Glänzen <i>Polish and chemical or electrochemical polish</i>

Bezeichnung 2 <i>Designation 2</i>	Farbe <i>Color</i>	Klasse <i>Class</i>	Schichtdicke [µm] <i>Layer thickness [µm]</i>	Lage und Beanspruchung <i>Location and stress</i>
EV 1	natur <i>Natural</i>	10	10	innen, trocken <i>Interior, dry</i>
EV 2	neusilber <i>Nickel silver</i>	15	15	innen, zeitweise nass /außen, ländliche Atmosphäre <i>Interior, temporarily wet / rural climate</i>
EV 3	gold <i>Gold</i>	20	20	außen, Stadt-und Industrielatmosphäre <i>Exterior, urban and rural climate</i>
EV 4	bronze mittel <i>Medium bronze</i>	25	25	aggressive Atmosphäre z.B.Kombination von Industrie- und Seeklima <i>Aggressive climate, e.g. a combination of industrial and maritime climate</i>
EV 5	bronze dunkel <i>Dark bronze</i>			
EV 6	schwarz <i>Black</i>			
C 0	farblos <i>Colorless</i>			
C 31	leichtbronze <i>Light bronze</i>			
C 32	hellbronze <i>Bright bronze</i>			
C 33	mittelbronze <i>Medium bronze</i>			

Beispiel: Angabe auf der Zeichnung

Example: Indication on drawing
DIN 17611 – E6/EV1 nature class 10 according to FATH 0073

1.4 Lackieren

Beim Lackieren wird eine komplett benetzte Oberfläche vorausgesetzt.

1.4 Painting

A completely covered surface is required.

1.5 Phosphatieren

Leichter bis mittlerer Korrosionsschutz, zusätzlich sehr gute Reib- und Gleiteigenschaften.

1.5. Phosphating

Light to medium corrosion protection. Low friction, good sliding properties.

1.6 Brünieren

Oberflächenbehandlung für Eisen, kein Korrosionsschutz. Tauchen in Ölemulsion. Oberflächenfärbung braun / schwarz.

1.6 Burnishing

Surface finishing for iron and steel parts, no corrosion protection. Dipping in oil emulsion. Surface coloring brown / black.

1.7 Chromatieren – Passivieren

Oberflächenbehandlung mit leichtem Korrosionsschutz bei Aluminium- und Zinkdruckgussteilen. Standard: gelb und farblos (Chrom VI-frei) Sehr guter Haftgrund für Lacke und Pulverbeschichtungen.

1.7 Chromate - Passivate

Surface finish with light corrosion protection for die-cast aluminum and zinc. Standard: yellow or colorless (chrome VI free) Very good primer for lacquers and powder coatings.



OBERFLÄCHENANGABEN BEI FATH
(Auszug aus der FATH-Norm 0073)

1.8 Gleitschleifen

Vorbehandlung für spätere Oberflächenbearbeitung (Lackieren, Pulverbeschichten...) Für Schüttgut mit kleineren Unebenheiten.

1.9 Sandstrahlen – Glasperlenstrahlen

Vorbehandlung für spätere Oberflächenbearbeitung (Lackieren, Pulverbeschichten...) Für Einzelteile.

1.10 Rauigkeit und Funktionsangaben von Oberflächen

1.10.1 Erodierstruktur bei sichtbaren Kunststoffoberflächen

Alle sichtbaren Oberflächen an Kunststoffteilen werden mit einer Erodierstruktur nach VDI 3400 versehen.

Keine Auswerfer an Sichtflächen erlaubt, soweit nicht anders angegeben.

Dieser Wert entspricht etwa einem Ra Wert von 6,3.

Vergleichstabelle VDI 3400 – DIN EN ISO 1302 (ca. Werte)
Comparison table VDI 3400 – DIN EN ISO 1302 (approx. values)

Wert VDI Value VDI	Wert DIN EN ISO 1302 [µm] Value DIN EN ISO 1302 [µm]	ISO 1302
18	0.8	N6
25	1.6	N7
30	3.2	N8
36	6.3	N9
42	12.5	N10
45	18	N10

Beispiel: Angabe auf der Zeichnung

Visible surfaces erode VDI 3400; Ref. No. XX according to FATH 0073

1.10.2 Oberflächenangaben nach DIN EN ISO 1302

Die bei FATH erstellten Zeichnungen haben in der Regel keine Oberflächenzeichen. Der Fertiger soll »so frei als möglich« bei der Fertigung sein, solange die Abmessungen eingehalten werden.

Sollten sich jedoch Oberflächenzeichen auf Zeichnungen befinden beziehen diese sich auf die DIN EN ISO 1302.

Die Angaben der Oberflächenzeichen beziehen sich auf den Ra-Wert, wenn nicht anders angegeben.

SURFACE SPECIFICATIONS AT FATH
(Excerpt from FATH norm 0073)

1.8 Barrel Finishing

Preparatory treatment for further finishing (coloring, powder coating...). For bulk ware with smaller irregularities.

1.9. Sandblasting – Glass Bead Blasting

Preparatory treatment for further finishing (coloring, powder coating...). For single parts.

1.10 Roughness and Function Specification of Surfaces

1.10.1 Erosion Structure on visible Plastic Surfaces

All visible surfaces of plastic parts have an eroded structure according to VDI 3400.

Ejectors may not be placed on visible surfaces if not indicated otherwise.

This is a Ra value of approximately 6.3.

Example: Indication on drawing

1.10.2 Surface Specifications According to DIN EN ISO 1302

Drawings created at FATH usually provide no surface specifications. Manufacturers are intended to be "as free as possible" in manufacturing as far as all dimensions are correct.

In case surface specifications are made on the drawing these are related to DIN ISO 1302.

If not indicated otherwise, surface specifications refer to the Ra-value.

Informationen *Information*

Technischer Anhang *Technical Annex*

Materialstandards *Material Standards*



INTERNATIONALE EDELSTAHL-STANDARDS

INTERNATIONAL STAINLESS STEEL STANDARDS

Deutschland <i>Germany</i>		U.S.A.	England <i>U.K.</i>	EU	Frankreich <i>France</i>	Italien <i>Italy</i>	Japan	Russland <i>Russia</i>	Schweden <i>Sweden</i>	Spanien <i>Spain</i>
W.N. 17007	DIN 17006	AISI	BSI	EURONORM	AFNOR	UNI	JIS	GOST	SIS	UNE
1.4000	X 6 Cr 13	410 S ³⁾	403S17	X 6 Cr 13	Z 6 C 13	X 6 Cr 13	SUS 410S		23 01	
1.4000	X 6 Cr 13	403 ³⁾	403S17	X 10 Cr 13	Z 12 C 13	X 12 Cr 13	SUS 403		23 02	
1.4006	X 10 Cr 13			X 12 Cr 13						
1.4024	X 15 Cr 13									
1.4000	X 6 Cr 13	410 ³⁾	410S21	X 12 Cr 13	Z 10 C 13	X 12 Cr 13	SUS 410	08Kh13	23 02	X 12 Cr 13
1.4006	X 10 Cr 13				Z 12 C 13					
1.4024	X 15 Cr 13									
1.4002	X 6 CrAl 13	405 ³⁾	405S17	X 6 CrAl 13	Z 6 CA 13	X 6 CrAl 13	SUS 405			X 6 CrAl 13
1.4104	X 6 CrMoS17	430 F ³⁾	441S01	X12CrMoS17	Z13 CF 17	X 10 CrS 17	SUS 430F		23 83	
1.4301	X 5 CrNi 18 10	304 ¹⁾	304S15	X 6 CrNi 18 10	Z 6 CN 18-09	X 5 CrNi 1810	SUS 304	08KH18N10	23 32	X 6 CrNi 19-10
1.4303	X 5 CrNi 18 12		304S16					06KH18N11		
1.4305	X 10 CrNiS 18 9	303 ¹⁾	303S21	X 10 CrNiS 18 9	Z 10 CNF 18-09	X 10 CrNiS 1809	SUS 303		23 46	X 10 CrNiS 18-09
1.4306	X 2 CrNi 18 11	304 L ¹⁾	304S11	X 3 CrNi 18 10	Z 2 CN 18-10	X 2 CrNi 1911	SUS 304L	03KH18N11	23 52	X 2 CrNi 19-10
1.4310	X 12 CrNi 17 7	301 ¹⁾	301S21	X 12 CrNi 17 7	Z 12 CN 17-07	X 12 CrNi 1707	SUS 301		23 31	X 12 CrNi 17-07
1.4311	X 2 CrNi 18 10				Z 2 CN 18-10-Az	X 2 CrNiN 1811	SUS 304LN		23 71	
1.4319	X 5 CrNi 18 7	302 ¹⁾	302S25	X 10 CrNi 18 9	Z 10 CN 18-09	X 10 CrNi 1809	SUS 302	12KH18N9	23 31	X 10 CrNi 18-09
1.4401	X 5 CrNiMo 17 12 2	316 ¹⁾	316S31	X 6 CrNiMo 17 12 2	Z 6 CND 17-11	X 5 CrNiMo 1712	SUS 316		23 47	X 6 CrNiMo 17-12-03
1.4404	X 2 CrNiMo 17 13 2	316 L ¹⁾	316S11	X 3 CrNiMo 17 12 2	Z 2 CND 17-12	X 2 CrNiMo 1712	SUS 316L		23 48	X 2 CrNiMo 17-12-03
1.4406	X 2 CrNiMoN 17 12 2				Z 2 CND 17-12-Az	X 2 CrNiMoN 1712	SUS 316LN	03KH16N15M3		
1.4427	X 12 CrNiMoS 18 11	316 F ¹⁾								
1.4429	X 2 CrNiMoN 17 13 3				Z 2 CND 17-13-Az	X 2 CrNiMoN 1713		08KH17N13M2T	23 75	
								10KH17N13M2T		
1.4435	X 2 CrNiMo 18 14 3	316 L ¹⁾	316S13	X 3 CrNiMo 17 13 3	Z 2 CND 17-13	X 2 CrNiMo 1713			23 53	X 2 CrNiMo 17-12-03
1.4436	X 5 CrNiMo 17 13 3	316 ¹⁾	316S33	X 6 CrNiMo 17 13 3	Z 6 CND 17-12	X 5 CrNiMo 1713	SUS 316		23 43	X 6 CrNiMo 17-12-03
1.4438	X 2 CrNiMo 18 16 4	317 L ¹⁾	317S12	X 3 CrNiMo 18 16 4	Z 2 CND 19-15	X 2 CrNiMo 1815	SUS 317L		23 67	
1.4438	X 2 CrNiMo 18 16 4	317 L ¹⁾	317S12	X 3 CrNiMo 18 16 4	Z 2 CND 19-15	X 2 CrNiMo 1816	SUS 317L		23 67	
1.4460	X 8 CrNiMo 27 5	329 ¹⁾					SUS 329J1	08KH18N12B	23 24	
1.4462	X 2 CrNiMoN 22 5	UNS31803 ²⁾								
1.4501	X 3 CrNiMoN 25 7	UNS32760 ²⁾			Z 3 CND 25-06Az		12Kh13			
1.4512	X 6 CrTi 12	409 ³⁾	409S19	X 5 CrTi 12	Z 6 CT 12	X 6 CrTi 12	SUH 409			
1.4541	X 6 CrNiTi 18 10	321 ¹⁾	321S31	X 6 CrNiTi 18 10	Z 6 CNT 18-10	X 6 CrNiTi 1811	SUS 321	12KH18N10T	23 37	X 6 CrNiTi 18-11
1.4878	X 12 CrNiTi 18 9									
1.4550	X 6 CrNiNb 18 10	347 ¹⁾	347S31	X 6 CrNiNb 18 10	Z 6 CNNb 18-10	X 6 CrNiNb 1811	SUS 347		23 38	X 6 CrNiNb 18-11
1.4571	X 6 CrNiMoTi 17 12 2		320S31	X 6 CrNiMoTi 17 12 2	Z 6 CNDT 17-12	X 6 CrNiMoTi 1712		08KH17N13M2T	23 50	X 6 CrNiMoTi 17-12-03
								10KH17N13M2T		
1.4573	X 10 CrNiMoTi 18 12		320S33	X 6 CrNiMoTi 17 13 3		X 6 CrNiMoTi 1713		08KH16N13M2B		X 6 CrNiMoTi 17-12-03
1.4580	X 6 CrNiMoNb 17 12 2			X 6 CrNiMoNb 17 12 2	Z 6 CNDNb 17-12	X 6 CrNiMoNb 1712		09KH16N15M3B		
1.4583	X 10 CrNiMoNb 18 12			X 6 CrNiMoNb 17 13 3		X 6 CrNiMoNb 1713				
1.4713	X 10 CrAl 7			X 10 CrAl 7	Z 8 CA 7			10Kh13SYu		
1.4724	X 10 CrAl 13					X 10 CrAl 12		15Kh18SYu		
1.4742	X 10 CrAl 18			X 10 CrSiAl 18						
1.4821	X 20 CrNiSi 25 4									
1.4828	X 15 CrNiS 20 12	309 ¹⁾	309S24	X 15 CrNi 23 13	Z 15 CN 24-13	X 16 CrNi 2314	SUH 309			
1.4841	X 15 CrNiSi 25 20	314 ¹⁾		X 15 CrNiSi 25 20	Z 12 CNS 25-20	X 16 CrNiSi 2520				
1.4842	X 12 CrNi 25 20	310 S ¹⁾		X 6 CrNi 25 20	Z 12 CN 25-20	X 5 CrNi 2520	SUS 310S	20KH25N20S2	23 61	
1.4845	X 12 CrNi 25 21	310 ¹⁾	310S24			X 22 CrNi 2520	SUH 310	10KH23N18		
1.4864	X 12 NiCrSi 36 16	330 ¹⁾			Z 12NCS 35-16		SUH 330	08KH18N10T		
1.4939		904 L ¹⁾			Z 12 CNDV 12-02					

1) austenitisch
2) austenitisch-ferritisch
3) ferritisch

1) austenitic grades
2) austenitic-ferritic grades
3) ferritic grades



UMRECHNUNGSFAKTOREN FÜR LÄNGENMAßE

CONVERSION FACTORS FOR LINEAR MEASURES

umzurechnen von <i>to convert from</i>	in <i>to</i>	multiplizieren mit <i>multiply by</i>
Zentimeter [cm]	Zoll <i>Inch</i> [in]	0,3937
Meter [m]	Yard [yd]	1,093
Kilometer [km]	Mile	0,6215
Zoll <i>Inch</i> [in]	Zentimeter [cm]	2,54
Yard [yd]	Meter [m]	0,9144
Mile	Kilometer [km]	1,609

1 Meter [m] = 100 cm = 1000 mm

1 foot [ft] = 12 in

1 yard [yd] = 3 ft = 36 in

UMRECHNUNGSFAKTOREN FÜR FLÄCHENMAßE

CONVERSION FACTORS FOR SQUARE MEASURES

umzurechnen von <i>to convert from</i>	in <i>to</i>	multiplizieren mit <i>multiply by</i>
Quadratcentimeter [cm ²]	Square inch [sqin]	0,155
Quadratmeter [m ²]	Square foot [sqft]	10,764
Quadratmeter [m ²]	Square Yard [yd ²]	1,196
Quadratkilometer [km ²]	Acre [ac]	247,1
Quadratkilometer [km ²]	Square Miles [sqmi]	0,3861
Square inch [sqin]	Quadratcentimeter [cm ²]	6,45
Square foot [sqft]	Quadratmeter [m ²]	0,093
Square Yard [yd ²]	Quadratmeter [m ²]	0,836
Acre [ac]	Quadratkilometer [km ²]	0,004
Square Miles [sqmi]	Quadratkilometer [km ²]	2,5899

1 Quadratkilometer [km²] = 100 Hektar [ha] =

10.000 Ar [a] = 1.000.000 Quadratmeter [m²]

1 Quadratmeter [m²] = 10.000 Quadratcentimeter [cm²] =

1.000.000 Quadratmillimeter [mm²]

1 Square Mile = 640 Acres [ac.]

1 Acres [ac.] = 4.840 Square Yards [sq yd]

1 Square Yard [sq yd] = 9 Square foot [sq ft]

UMRECHNUNGSFAKTOREN FÜR RAUMMAßE

CONVERSION FACTORS FOR SOLID MEASURES

umzurechnen von <i>to convert from</i>	in <i>to</i>	multiplizieren mit <i>multiply by</i>
Liter [l]	Cubic inch [cu in]	61.025
Liter [l]	Cubic foot [cu ft]	0.0353
Liter [l]	US-Quart	1.0567
Liter [l]	US-Gallon	0.2642
Liter [l]	GB-Gallon	0.2200
Kubikcentimeter [cm ³] / Milliliter [ml]	Cubic Inch [cu in]	0.061
Cubic Inch [sq in]	Kubikcentimeter [cm ³] / Milliliter [ml]	16.387
Cubic Inch [cu in]	Liter [l]	0.0163
Cubic Foot [cu ft]	Liter [l]	28.317
GB-Gallon	Liter [l]	4.545
US-Gallon	Liter [l]	3.7853
US-Quart	Liter [l]	0.9463
1 Barrel [Ölmaß]	Liter [l]	159

1 Kubikmeter [m³] = 1.000 Kubikdezimeter [dm³] = 1.000.000 Kubikcentimeter [cm³] / Milliliter [ml]

1 Hektoliter [hl] = 100 Liter [l] = 100 Kubikdezimeter [dm³] = 1.000 Deziliter [dl]



UMRECHNUNGSFAKTOREN FÜR GEWICHTE

CONVERSION FACTORS FOR WEIGHTS

umzurechnen von <i>to convert from</i>	in <i>to</i>	multiplizieren mit <i>multiply by</i>
Gramm [g]	Ounce [oz]	0,0353
Kilogramm [kg]	Pound [lb]	2,2046
Ounce [oz]	Gramm [g]	28,3495
Pound [lb]	Kilogramm [kg]	0,45359

1 Kilogramm [kg] = 1000 g

1 Pound [lb] = 16 oz

UMRECHNUNGSFAKTOREN FÜR TEMPERATUREN

CONVERSION FACTORS FOR TEMPERATURES

umzurechnen von <i>to convert from</i>	in <i>to</i>	Formel <i>Formula</i>
Fahrenheit [°F]	Celsius [°C]	°C = (°F-32) x 5/9
Celsius [°C]	Fahrenheit [°F]	°F = 9/5 x °C + 32

0 °F = -17,8 °C
 32 °F = 0 °C
 50 °F = 10 °C
 212 °F = 100 °C

0 °C = 32 °F
 10 °C = 50 °F
 37 °C = 98,6 °F
 100 °C = 212 °F

UMRECHNUNGSFAKTOREN FÜR GESCHWINDIGKEIT

CONVERSION FACTORS FOR SPEED

umzurechnen von <i>to convert from</i>	in <i>to</i>	multiplizieren mit <i>multiply by</i>
Stundenkilometer [km/h]	Miles per hour [mph]	0,6215
Miles per hour [mph]	Stundenkilometer [km/h]	1,609

55 mph = 89 km/h
 60 mph = 96 km/h
 65 mph = 104 km/h
 70 mph = 113 km/h
 75 mph = 121 km/h

30 km/h = 19 mph
 50 km/h = 31 mph
 80 km/h = 50 mph
 100 km/h = 62 mph
 130 km/h = 81 mph

UMRECHNUNGSTABELLE ZOLL (INCH) – MM

CONVERSION TABLE INCH – MM

Zoll Inches (Fraction)	Dezimalzoll Decimal Inches	Zoll Inches											
		0"	1"	2"	3"	4"	5"	6"	7"	8"	9"	10"	11"
		Millimeter Millimeters											
0"	0,0000	0,00	25,40	50,80	76,20	101,60	127,00	152,40	177,80	203,20	228,60	254,00	279,40
1/64"	0,0156	0,40	25,80	51,20	76,60	102,00	127,40	152,80	178,20	203,60	229,00	254,40	279,80
1/32	0,0313	0,79	26,19	51,59	76,99	102,39	127,79	153,19	178,59	203,99	229,39	254,79	280,19
3/64	0,0469	1,19	26,59	51,99	77,39	102,79	128,19	153,59	178,99	204,39	229,79	255,19	280,59
1/16	0,0625	1,59	26,99	52,39	77,79	103,19	128,59	153,99	179,39	204,79	230,19	255,59	280,99
5/64	0,0781	1,98	27,38	52,78	78,18	103,58	128,98	154,38	179,78	205,18	230,58	255,98	281,38
3/32	0,0938	2,38	27,78	53,18	78,58	103,98	129,38	154,78	180,18	205,58	230,98	256,38	281,78
7/64	0,1094	2,78	28,18	53,58	78,98	104,38	129,78	155,18	180,58	205,98	231,38	256,78	282,18
1/8	0,1250	3,18	28,58	53,98	79,38	104,78	130,18	155,58	180,98	206,38	231,78	257,18	282,58
9/64	0,1406	3,57	28,97	54,37	79,77	105,17	130,57	155,97	181,37	206,77	232,17	257,57	282,97
5/32	0,1563	3,97	29,37	54,77	80,17	105,57	130,97	156,37	181,77	207,17	232,57	257,97	283,37
11/64	0,1719	4,37	29,77	55,17	80,57	105,97	131,37	156,77	182,17	207,57	232,97	258,37	283,77
3/16	0,1875	4,76	30,16	55,56	80,96	106,36	131,76	157,16	182,56	207,96	233,36	258,76	284,16
13/64	0,2031	5,16	30,56	55,96	81,36	106,76	132,16	157,56	182,96	208,36	233,76	259,16	284,56
7/32	0,2188	5,56	30,96	56,36	81,76	107,16	132,56	157,96	183,36	208,76	234,16	259,56	284,96
15/64	0,2344	5,95	31,35	56,75	82,15	107,55	132,95	158,35	183,75	209,15	234,55	259,95	285,35
1/4	0,2500	6,35	31,75	57,15	82,55	107,95	133,35	158,75	184,15	209,55	234,95	260,35	285,75
17/64	0,2656	6,75	32,15	57,55	82,95	108,35	133,75	159,15	184,55	209,95	235,35	260,75	286,15
9/32	0,2813	7,14	32,54	57,94	83,34	108,74	134,14	159,54	184,94	210,34	235,74	261,14	286,54
19/64	0,2969	7,54	32,94	58,34	83,74	109,14	134,54	159,94	185,34	210,74	236,14	261,54	286,94
5/16	0,3125	7,94	33,34	58,74	84,14	109,54	134,94	160,34	185,74	211,14	236,54	261,94	287,34
21/64	0,3281	8,33	33,73	59,13	84,53	109,93	135,33	160,73	186,13	211,53	236,93	262,33	287,73
11/32	0,3438	8,73	34,13	59,53	84,93	110,33	135,73	161,13	186,53	211,93	237,33	262,73	288,13
23/64	0,3594	9,13	34,53	59,93	85,33	110,73	136,13	161,53	186,93	212,33	237,73	263,13	288,53
3/8	0,3750	9,53	34,93	60,33	85,73	111,13	136,53	161,93	187,33	212,73	238,13	263,53	288,93
25/64	0,3906	9,92	35,32	60,72	86,12	111,52	136,92	162,32	187,72	213,12	238,52	263,92	289,32
13/32	0,4063	10,32	35,72	61,12	86,52	111,92	137,32	162,72	188,12	213,52	238,92	264,32	289,72
27/64	0,4219	10,72	36,12	61,52	86,92	112,32	137,72	163,12	188,52	213,92	239,32	264,72	290,12
7/16	0,4375	11,11	36,51	61,91	87,31	112,71	138,11	163,51	188,91	214,31	239,71	265,11	290,51
29/64	0,4531	11,51	36,91	62,31	87,71	113,11	138,51	163,91	189,31	214,71	240,11	265,51	290,91
15/32	0,4688	11,91	37,31	62,71	88,11	113,51	138,91	164,31	189,71	215,11	240,51	265,91	291,31
31/64	0,4844	12,30	37,70	63,10	88,50	113,90	139,30	164,70	190,10	215,50	240,90	266,30	291,70
1/2	0,5000	12,70	38,10	63,50	88,90	114,30	139,70	165,10	190,50	215,90	241,30	266,70	292,10
33/64	0,5156	13,10	38,50	63,90	89,30	114,70	140,10	165,50	190,90	216,30	241,70	267,10	292,50
17/32	0,5313	13,49	38,89	64,29	89,69	115,09	140,49	165,89	191,29	216,69	242,09	267,49	292,89
35/64	0,5469	13,89	39,29	64,69	90,09	115,49	140,89	166,29	191,69	217,09	242,49	267,89	293,29
9/16	0,5625	14,29	39,69	65,09	90,49	115,89	141,29	166,69	192,09	217,49	242,89	268,29	293,69
37/64	0,5781	14,68	40,08	65,48	90,88	116,28	141,68	167,08	192,48	217,88	243,28	268,68	294,08
19/32	0,5938	15,08	40,48	65,88	91,28	116,68	142,08	167,48	192,88	218,28	243,68	269,08	294,48
39/64	0,6094	15,48	40,88	66,28	91,68	117,08	142,48	167,88	193,28	218,68	244,08	269,48	294,88
5/8	0,6250	15,88	41,28	66,68	92,08	117,48	142,88	168,28	193,68	219,08	244,48	269,88	295,28
41/64	0,6406	16,27	41,67	67,07	92,47	117,87	143,27	168,67	194,07	219,47	244,87	270,27	295,67
21/32	0,6563	16,67	42,07	67,47	92,87	118,27	143,67	169,07	194,47	219,87	245,27	270,67	296,07
43/64	0,6719	17,07	42,47	67,87	93,27	118,67	144,07	169,47	194,87	220,27	245,67	271,07	296,47
11/16	0,6875	17,46	42,86	68,26	93,66	119,06	144,46	169,86	195,26	220,66	246,06	271,46	296,86
45/64	0,7031	17,86	43,26	68,66	94,06	119,46	144,86	170,26	195,66	221,06	246,46	271,86	297,26
23/32	0,7188	18,26	43,66	69,06	94,46	119,86	145,26	170,66	196,06	221,46	246,86	272,26	297,66
47/64	0,7344	18,65	44,05	69,45	94,85	120,25	145,65	171,05	196,45	221,85	247,25	272,65	298,05
3/4	0,7500	19,05	44,45	69,85	95,25	120,65	146,05	171,45	196,85	222,25	247,65	273,05	298,45
49/64	0,7656	19,45	44,85	70,25	95,65	121,05	146,45	171,85	197,25	222,65	248,05	273,45	298,85
25/32	0,7813	19,84	45,24	70,64	96,04	121,44	146,84	172,24	197,64	223,04	248,44	273,84	299,24
51/64	0,7969	20,24	45,64	71,04	96,44	121,84	147,24	172,64	198,04	223,44	248,84	274,24	299,64
13/16	0,8125	20,64	46,04	71,44	96,84	122,24	147,64	173,04	198,44	223,84	249,24	274,64	300,04
53/64	0,8281	21,03	46,43	71,83	97,23	122,63	148,03	173,43	198,83	224,23	249,63	275,03	300,43
27/32	0,8438	21,43	46,83	72,23	97,63	123,03	148,43	173,83	199,23	224,63	250,03	275,43	300,83
55/64	0,8594	21,83	47,23	72,63	98,03	123,43	148,83	174,23	199,63	225,03	250,43	275,83	301,23
7/8	0,8750	22,23	47,63	73,03	98,43	123,83	149,23	174,63	200,03	225,43	250,83	276,23	301,63
57/64	0,8906	22,62	48,02	73,42	98,82	124,22	149,62	175,02	200,42	225,82	251,22	276,62	302,02
29/32	0,9063	23,02	48,42	73,82	99,22	124,62	150,02	175,42	200,82	226,22	251,62	277,02	302,42
59/64	0,9219	23,42	48,82	74,22	99,62	125,02	150,42	175,82	201,22	226,62	252,02	277,42	302,82
15/16	0,9375	23,81	49,21	74,61	100,01	125,41	150,81	176,21	201,61	227,01	252,41	277,81	303,21
61/64	0,9531	24,21	49,61	75,01	100,41	125,81	151,21	176,61	202,01	227,41	252,81	278,21	303,61
31/32	0,9688	24,61	50,01	75,41	100,81	126,21	151,61	177,01	202,41	227,81	253,21	278,61	304,01
63/64	0,9844	25,00	50,40	75,80	101,20	126,60	152,00	177,40	202,80	228,20	253,60	279,00	304,40



INDEX NACH TEILENUMMERN

PART NUMBER INDEX

Bodenelemente <i>Floor Elements</i>	1
Scharniere <i>Hinges</i>	2
Nutmuttern und -schrauben <i>T-Nuts and T-Bolts</i>	3
Verbindungstechnik <i>Connecting Systems</i>	4
Griffe und Verschlüsse <i>Handles and Latches</i>	5
Arbeitsplatzkomponenten <i>Components for Work Stations</i>	6
Gleiter und Rollen <i>Sliders and Rollers</i>	7
Fördertechnik <i>Conveyors</i>	8
Schutz- und Trennwandelemente <i>Enclosures, Guards, Partitions</i>	9
Flächenbefestigungen <i>Panel Fasteners</i>	10
Abdeckelemente <i>Cover Elements</i>	11
Kabelführungen <i>Cable Management</i>	12
Diverse Komponenten <i>Miscellaneous Components</i>	13
Rundrohrkomponenten <i>Tubular Frame Components</i>	14



INDEX NACH TEILENUMMERN

PART NUMBER INDEX

051DC551520MM0610	649	062ACR991ESD.50	644	062MGRC91.xxxx	631	091021	736	091236	731
051DC552020MM0610	649	062ACS91.25	645	062MGRC91ESD.4500	631	091023	733	091245	732
051DC553030FM08	651	062AEB91ESD.50	637	062MGRC91ESD.xxxx	631	091024	734	091246	741
051DKP552420MM0618	650	062AEQE.50	636	062MGRL3274.4500	630	091027	732	091247	741
06001HR2000	128	062AER2811.50	632	062MGRL3274.xxxx	630	091028	735	091248L	741
06001HR500E	129	062AER2831.50	632	062MGRL3291.4500	630	091030	734	091248R	741
06001HR500EZ4	129	062AER2861.50	632	062MGRL3291.xxxx	630	091042	731	091249L	741
061MA2291NESDS01	572	062AER2874.50	632	062MGRL3291ESD.4500	630	091043	731	091249R	741
061MA2291NS01	572	062AER2891.50	632	062MGRL3291ESD.xxxx	630	091045	733	091252	732
061MA291D	784	062AER2891ESD.50	632	062MGRL6574.4500	630	091046	733	091276	734
061MGC2D291N08	569	062AER28F11.50	632	062MGRL6574.xxxx	630	091048	733	091278	733
061MGC2D291N10	569	062AER28F31.50	632	062MGRL6591.4500	630	091049	737	091320	733
061MGC2K291H	570	062AER28F61.50	632	062MGRL6591.xxxx	630	091050	731	091332	731
061MGC2K291HESD	570	062AER28F74.50	632	062MGRL6591ESD.4500	630	091065	739	091333	743
061MGC4D291N08	569	062AER28F91.50	632	062MGRL6591ESD.xxxx	630	091066	739	091337	738
061MGC4D291N10	569	062AER28F91ESD.50	632	062MHD28M	626	091067	739	091337S01	738
061MGT2D311H	568	062AER91.50	617	062MHSD28M	626	091068	739	091344	732
061MGT2D311N08	567	062AER911.50	635	062MMD28M	628	091069	739	091345S01	733
061MGT2D311N10	567	062AER91ESD.50	617	062MVM	656	091070	739	091346	732
061MGT2D331H	568	062AER931.50	635	062MYFD28M	627	091071	739	091347	740
061MGT2D331N08	567	062AER961.50	635	062MYMD28M	627	091072	739	091348	740
061MGT2D331N10	567	062AER974.50	635	062RBH26E	634	091073	739	091349	740
061MGT2D361H	568	062AER991.50	635	062RBR28E	633	091074	739	091359	732
061MGT2D361N08	567	062AER991ESD.50	635	062RH2611	639	091077	733	091370	732
061MGT2D361N10	567	062AEVMESD.50	655	062RH2631	639	091078	733	091370S01	732
061MGT2D374H	568	062AHD28M	623	062RH2661	639	091083	734	091371	732
061MGT2D374N08	567	062AHD28MS01	623	062RH2674	639	091094	733	091374S01	742
061MGT2D374N10	567	062AHS28M	623	062RH2691	639	091095	733	092001	528
061MGT2D391H	568	062AHS28MS01	623	062RH2691ESD	639	091107	414	092002	528
061MGT2D391HESD	568	062AMD28M	625	062RR2811	638	091108	414	092005	527
061MGT2D391N08	567	062AMD28MS01	625	062RR2831	638	091118	733	092008	533
061MGT2D391N08ESD	567	062APB.6000	622	062RR2861	638	091125	731	092009	532
061MGT2D391N10	567	062APB.xxxx	622	062RR2874	638	091135	733	092010	532
061MGT2D391N10ESD	567	062APBESD.6000	622	062RR2891	638	091137	733	092012	530
061MTC2K291H	571	062APBESD.xxxx	622	062RR2891ESD	638	091141	732	092013	535
061MTC2K291HESD	571	062API.6000	622	062RR28F11	638	091168	741	092013A.2000	536
061SAP40H	580	062API.xxxx	622	062RR28F31	638	091179	732	092013A200	536
061SM7510040	575	062APIESD.6000	622	062RR28F61	638	091180	731	092013A300	536
062ABKESD	647	062APIESD.xxxx	622	062RR28F74	638	091181	731	092013A400	536
062ACD2491ESD.50	648	062AQE	646	062RR28F91	638	091182	731	092013A500	536
062ACEH2674.10	643	062AS91.2000	616	062RR28F91ESD	638	091183	731	092013C.2000	536
062ACEH2691.10	643	062AS91ESD.2000	616	062RR911	640	091184	732	092013C200	536
062ACEH2691ESD.10	643	062AT4040	629	062RR931	640	091185	732	092013C300	536
062ACH2674.50	643	062AT4040S01	629	062RR961	640	091186	732	092013C400	536
062ACH2691.50	643	062ATS4080	629	062RR974	640	091187	732	092013C500	536
062ACH2691ESD.50	643	062ATS4080S01	629	062RR991	640	091188	732	092013E.2000	536
062ACR2874.33	642	062AXM	641	062RR991ESD	640	091194	741	092013E200	536
062ACR2874.50	642	062AYFD28M	624	091002	734	091195	741	092013E300	536
062ACR2891.33	642	062AYFD28MS01	624	091006	734	091201	741	092013E400	536
062ACR2891.50	642	062AYMD28M	624	091007	733	091202	741	092013E500	536
062ACR2891ESD.33	642	062AYMD28MS01	624	091009	733	091203	741	092013S.2000	536
062ACR2891ESD.50	642	062MGRC74.4500	631	091011	734	091204	741	092013S200	536
062ACR974.50	644	062MGRC74.xxxx	631	091015	734	091207	734	092013S300	536
062ACR991.50	644	062MGRC91.4500	631	091017	734	091209	733	092013S400	536



INDEX NACH TEILENUMMERN

PART NUMBER INDEX

092013S500	536	092045	719	092259	561	093084L	598	093251	750
092017	530	092047	696	092260	701	093084R	598	093254	750
092017S02	530	092047	719	092300	534	093084S01	598	093254S03	750
092017S03	530	092050	725	092301	534	093087S01	596	093258	750
092017S04	530	092050A	725	092302	534	09308801	500	093310	714
092018	530	092050AS01	725	092303	534	09308802	416	093320	715
092018S02	530	092050S03	725	092304	534	09308802	500	093401	748
092018S03	530	092050S04	725	092305	534	09308901	574	093401N08	748
092018S04	530	092050S07	725	092307	531	09308901S01	574	093401N10	748
092019	530	092050S12	725	092307S01	531	09308902	574	093402N08	751
092020	565	092052	725	092308	531	09308902S01	574	093403N08	751
092020	566	092054	725	092308S01	531	093090	758	093405N08	751
092021	537	092055	727	092311N08	744	093091	761	093406N10	751
092022	537	092057	730	092318	565	09309301	611	093407N05	751
092023	537	092058	730	092318	566	09309302	612	093408N6,5	751
092024	537	092060	767	092321	535	09309302S01	612	093504N08	752
092030	699	092060S01	767	093001	566	09309302S02	612	093505N08	752
092030	723	092063	711	093006	566	09309302S03	612	093506N10	752
092031	699	092064	711	093007	566	09309303	611	093510N05	752
092031	723	092065	710	093009	565	09309304	612	093512N6,5	752
092031S03	699	092066	711	093020	603	09309304S01	612	093600AB06	753
092031S03	723	092070	729	093021	603	09309304S03	612	093600AB08	753
092031S04	699	092071	728	093022	603	09309304S04	612	093600B06	753
092031S04	723	092080	726	093024	604	093094	548	093600B08	753
092033	698	092080A	726	093025	604	093095	599	093610AN10	753
092033	721	092081	726	093026	605	093096S01	760	093610N10	753
092033S01	698	092082	726	093028	601	093097	599	093611AN08	753
092033S01	721	092085	726	093029	602	093098	599	093611N08	753
092034	698	092090	712	093039	555	093099S01	759	093B1201N06R	111
092034	721	092092	449	093040	549	093099S02	759	093B1201N06RS01	112
092035	699	092093	709	093040W	550	093099S03	759	093B1201N06S	111
092035	723	092093S02	709	093043	552	093100E	654	093B1201N06SS01	112
092036	699	092094	703	093043A4	553	093100K	654	093B1201N06SS02	111
092036	723	092095	618	093043S02	552	093100M	654	093B1201N06SS03	112
092037	699	092095S01	618	093043W	554	093101	606	093B1201N08R	111
092037	723	092096	713	093044	549	093110	559	093B1201N08RS01	112
092038	447	092130	722	093045	552	093111	560	093B1201N08S	111
092039	447	092130A	722	093045S03	552	093156	763	093B1201N08SS01	112
092040	447	092130S01	722	093046	548	093160	667	093B1201N10R	111
092040E	447	092140	448	0930461	557	093166	763	093B1201N10RS01	112
092040N12	447	092242	700	0930462	557	093166SW	763	093B1201N10S	111
092041	725	092242	724	0930463	557	093169	763	093B1201N10SS01	112
092041A	725	092243	702	0930464	557	093169SW	763	093B1601N08R	113
092041AS01	725	092244	705	09304701	556	093200	652	093B1601N08RS01	114
092041S03	725	092246	697	09304702	556	093200S01	652	093B1601N08S	113
092041S05	725	092246	720	093048	659	093212	653	093B1601N08SS01	114
092041S06	725	092251	704	093050	749	093213	653	093B1601N08SS02	114
092041S08	725	092252	706	093050S03	749	093214	653	093B1601N08SS05	113
092041S13	725	092253	706	093051	749	093215	653	093B1601N10R	113
092042	725	092254	708	093054	749	093216	653	093B1601N10RS01	114
092043	725	092255	708	093054S03	749	093217	653	093B1601N10S	113
092044	725	092256	707	093058	749	093218	653	093B1601N10SS01	114
092044S01	725	092257	561	093059	747	093249	750	093B2001S	115
092045	696	092258	561	093082	558	093249S03	750	093B2001V	115



INDEX NACH TEILENUMMERN

PART NUMBER INDEX

093B2002S	116	093GF30AN06	481	093SB10N08	762	093T30601406R	99	093T45902012R	103
093B2002V	116	093GF30AN08	481	093SB10N08ESD	762	093T30601406S	99	093T45902012S	103
093BA14020	107	093GF3876AN	487	093SB10N10	762	093T30601408R	99	093T501001010R	105
093BA14025	107	093GF38A	485	093SB10N10ESD	762	093T30601408S	99	093T501001010S	105
093BA14030	107	093GF38AN08	485	093SB40N08	762	093T30601606R	99	093T501001012R	105
093BA14038	107	093GF4080AN	491	093SB40N08ESD	762	093T30601606S	99	093T501001012S	105
093BA14040	107	093GF40AN	489	093SB40N10	762	093T30601608R	99	093T501001210R	105
093BA14045	107	093GF4590AN	497	093SB40N10ESD	762	093T30601608S	99	093T501001210S	105
093BA140D40	108	093GF45AN	495	093SF0516	420	093T40400805R	98	093T501001212R	105
093BA140D60	108	093GV20	498	093SF0725	420	093T40400805S	98	093T501001212S	105
093BA140D76	108	093GV2040	499	093SF0740	420	093T40401005R	98	093T501001410R	105
093BA140D80	108	093GV30	498	093SF1240	420	093T40401005S	98	093T501001410S	105
093BA140D90	108	093GV3060	499	093SM06S02	592	093T40401205R	98	093T501001412R	105
093CWM35N0810	660	093GV40	498	093SM08	594	093T40401205S	98	093T501001412S	105
093FDE30N0810	597	093GV4080	499	093SM0810	595	093T40800808R	101	093T501001610R	105
093G25A	476	093GV45	498	093SM08S02	592	093T40800808S	101	093T501001610S	105
093G25AN06	476	093GV4590	499	093SM10	594	093T40800812R	101	093T501001612R	105
093G28A	478	093LC23N08S01.102	573	093SM10S01	593	093T40800812S	101	093T501001612S	105
093G28AN08	478	093LC23N08S01.2000	573	093SM10S02	592	093T40801008R	101	093T501002010R	105
093G30A	480	093LC36N0810S01.102	573	093SN10	600	093T40801008S	101	093T501002010S	105
093G30AN06	480	093LC36N0810S01.160	573	093T1001001008R	106	093T40801012R	101	093T501002012R	105
093G30AN08	480	093LC36N0810S01.2000	573	093T1001001008S	106	093T40801012S	101	093T501002012S	105
093G3876AN	486	093LC38D28S01.120	785	093T1001001012R	106	093T40801208R	101	093T60600806R	100
093G38A	484	093LC38D28S01.2000	785	093T1001001012S	106	093T40801208S	101	093T60600806S	100
093G38AN08	484	093LCT38D28.120	785	093T1001001208R	106	093T40801212R	101	093T60600808R	100
093G4080AN	490	093LCT38D28.2000	785	093T1001001208S	106	093T40801212S	101	093T60600808S	100
093G40AN	488	093M1230	421	093T1001001212R	106	093T40801408R	101	093T60601006R	100
093G4590AN	496	093M1230T	421	093T1001001212S	106	093T40801408S	101	093T60601006S	100
093G45AN	494	093P20LN	661	093T1001001408R	106	093T40801412R	101	093T60601008R	100
093GA2040A	474	093P20N	716	093T1001001408S	106	093T40801412S	101	093T60601008S	100
093GA2040AN05	474	093P30LN	661	093T1001001412R	106	093T40801608R	101	093T60601206R	100
093GA2040AN06	474	093P30N	716	093T1001001412S	106	093T40801608S	101	093T60601206S	100
093GA20AN	470	093P40LN	661	093T1001001608R	106	093T40801612R	101	093T60601208R	100
093GA3060A	482	093P40N	716	093T1001001608S	106	093T40801612S	101	093T60601208S	100
093GA3060AN06	482	093P45LN	661	093T1001001612R	106	093T40802008R	101	093T60601406R	100
093GA3060AN08	482	093P45N	716	093T1001001612S	106	093T40802008S	101	093T60601406S	100
093GA45AN	492	093PS0840	583	093T1001002008R	106	093T45901008R	103	093T60601408R	100
093GAB20AN05	472	093PS0840F	585	093T1001002008S	106	093T45901008S	103	093T60601408S	100
093GAB20AN06	472	093PS0840FS01	588	093T1001002012R	106	093T45901012R	103	093T60601606R	100
093GABF20AN05	473	093PS0840FS02	591	093T1001002012S	106	093T45901012S	103	093T60601606S	100
093GABF20AN06	473	093PS0840L	584	093T20400605R	97	093T45901208R	103	093T60601608R	100
093GAF2040A	475	093PS0840LS01	587	093T20400605S	97	093T45901208S	103	093T60601608S	100
093GAF2040AN05	475	093PS0840LS02	590	093T30600806R	99	093T45901212R	103	093T80800808R	102
093GAF2040AN06	475	093PS0840S01	586	093T30600806S	99	093T45901212S	103	093T80800808S	102
093GAF20AN	471	093PS0840S02	589	093T30600808R	99	093T45901408R	103	093T80800812R	102
093GAF3060A	483	093QFN10	754	093T30600808S	99	093T45901408S	103	093T80800812S	102
093GAF3060AN06	483	093RD84040R4	522	093T30601006R	99	093T45901412R	103	093T80801008R	102
093GAF3060AN08	483	093S0616T	419	093T30601006S	99	093T45901412S	103	093T80801008S	102
093GAF45AN	493	093S0716C	417	093T30601008R	99	093T45901608R	103	093T80801012R	102
093GF25A	477	093S0720M	418	093T30601008S	99	093T45901608S	103	093T80801012S	102
093GF25AN06	477	093S0725T	419	093T30601206R	99	093T45901612R	103	093T80801208R	102
093GF28A	479	093S0825C	417	093T30601206S	99	093T45901612S	103	093T80801208S	102
093GF28AN08	479	093S0825T	419	093T30601208R	99	093T45902008R	103	093T80801212R	102
093GF30A	481	093S1230T	419	093T30601208S	99	093T45902008S	103	093T80801212S	102



INDEX NACH TEILENUMMERN

PART NUMBER INDEX

093T80801408R	102	093V4590S	329	093W03	344	093W401N08S03	352	093W603N10S03	345
093T80801408S	102	093V4590V	329	093W03	350	093W401N10	352	093W603N10S04	345
093T80801412R	102	093VA2040	321	093W1171L	109	093W401N10R	352	093W802	355
093T80801412S	102	093VA2080	322	093W1171LN06	109	093W401R	352	093W802N08	355
093T80801608R	102	093VA30120	322	093W1171LN08	109	093W402	353	093W802N08R	355
093T80801608S	102	093VA3060	321	093W1751LN10	110	093W402N08	353	093W802N08S02	355
093T80801612R	102	093VA38152	322	093W201	349	093W402N08R	353	093W802N10	355
093T80801612S	102	093VA3876	321	093W201N05	349	093W402N08S02	353	093W802N10R	355
093T80802008R	102	093VA40160	322	093W201N05R	349	093W402N10	353	093W802R	355
093T80802008S	102	093VA4040	323	093W201N05S01	349	093W402N10R	353	093W803	357
093T80802012R	102	093VA4080	321	093W201N06	349	093W402R	353	093W803N08	357
093T80802012S	102	093VA45180	322	093W201N06R	349	093W403	340	093W803N08R	357
093T90901008R	104	093VA4590	321	093W201R	349	093W403N08	340	093W803N10	357
093T90901008S	104	093VA6060	323	093W202	336	093W403N10	340	093W803N10R	357
093T90901012R	104	093VA7676	323	093W202N05	336	093W403N10S01	340	093W803R	357
093T90901012S	104	093VA8080	323	093W202N06	336	093W403N10S03	340	093W805	348
093T90901208R	104	093VA9090	323	093W202N06S03	336	093W403N10S04	340	093W805S01	348
093T90901208S	104	093VAD28V	776	093W202N06S04	336	093W404	339	093W806	346
093T90901212R	104	093VB3060N08	394	093W202N06S05	336	093W404N08	339	093W806N08	346
093T90901212S	104	093VB3060N08S01	394	093W203	335	093W404N10	339	093W806N10	346
093T90901408R	104	093VD4080	324	093W203N05	335	093W404N10S01	339	093W806N10S01	346
093T90901408S	104	093VD60120	324	093W203N06	335	093W404N10S05	339	093W806N10S03	346
093T90901412R	104	093VD76152	324	093W203N06S01	335	093W404N10S06	339	093W806N10S04	346
093T90901412S	104	093VD80160	324	093W203N06S03	335	093W421	341	093W807	358
093T90901608R	104	093VD90180	324	093W203N06S04	335	093W421N08	341	093W901	347
093T90901608S	104	093VL114114	325	093W206N08R	350	093W421N10	341	093W901N08	347
093T90901612R	104	093VL120120	325	093W206N08RS02	350	093W421N10S04	341	093W901N10	347
093T90901612S	104	093VL120120D	326	093W301	351	093W421N10S08	341	093W901N10S02	347
093T90902008R	104	093VL135135	325	093W301N06	351	093W421N10S09	341	093W901N10S06	347
093T90902008S	104	093VL152152D	326	093W301N06R	351	093W422N10	343	093W901N10S07	347
093T90902012R	104	093VL160160D	326	093W301N06S01	351	093W422N10S01	343	093WA1171L	109
093T90902012S	104	093VL180180D	326	093W301N08	351	093W423N10	342	093WA201	349
093TA40800808R	95	093VL6060	325	093W301N08R	351	093W423N10S02	342	093WA202	336
093TA40801008R	95	093VL8080D	326	093W301R	351	093W451	344	093WA203	335
093TA40801208R	95	093VL9090	325	093W302	338	093W451N08	344	093WA301	351
093TA40801408R	95	093VT114114	327	093W302N06	338	093W451N10	344	093WA302	338
093TA40801608R	95	093VT120120	327	093W302N08	338	093W451N10S01	344	093WA303S02	337
093TA40802008R	95	093VT120120D	328	093W302N08S01	338	093W451N10S05	344	093WA401	352
093TA80800808R	96	093VT135135	327	093W302N08S04	338	093W451N10S06	344	093WA401S01	352
093TA80801008R	96	093VT152152D	328	093W302N08S05	338	093W601	356	093WA402	353
093TA80801208R	96	093VT160160D	328	093W303	337	093W601N08	356	093WA403	340
093TA80801408R	96	093VT180180D	328	093W303N06	337	093W601N08R	356	093WA404	339
093TA80801608R	96	093VT6060	327	093W303N08	337	093W601N10	356	093WA421S02	341
093TA80802008R	96	093VT8080D	328	093W303N08S09	337	093W601N10R	356	093WA421S02	342
093V1001N08V	330	093VT9090	327	093W303N08S11	337	093W601R	356	093WA422	343
093V1001N10V	330	093W02	337	093W303N08S12	337	093W603	345	093WA451	344
093V2040S	329	093W02	338	093W303N08S13	337	093W603N08	345	093WA601	356
093V3060S	329	093W02	341	093W303N08S14	337	093W603N08S01	345	093WA603	345
093V3060V	329	093W02	345	093W303N10	337	093W603N08S02	345	093WA802	355
093V3090S	329	093W02	346	093W303N10S02	337	093W603N08S03	345	093WA803	357
093V40120S	329	093W02	347	093W303N10S03	337	093W603N08S04	345	093WA806	346
093V40160S	329	093W02	507	093W401	352	093W603N08S05	345	093WA901	347
093V4080S	329	093W03	109	093W401N08	352	093W603N10	345	093WD20	331
093V4080V	329	093W03	339	093W401N08R	352	093W603N10S01	345	093WD2040	332



INDEX NACH TEILENUMMERN

PART NUMBER INDEX

093WD25	331	093WG302N08S05	507	093WS45245N10	465	093WW408N10RS	405	094102	682
093WD2551	332	093WG302N08S06	507	093WS45245N10R	465	093WW408N10S	405	094102CS	676
093WD30	331	093WG302N10	507	093WS51145N6,5	457	093WW453N10	406	094102CS	678
093WD3060	332	093WG302N10S01	507	093WS51145N6,5R	457	093WW453N10R	406	094102G	679
093WD38	331	093WG302N10S02	507	093WS60145N08	459	093WW453N10RS	406	094102K	688
093WD3876	332	093WG302N10S03	507	093WS60145N08R	459	093WW453N10S	406	094102K	689
093WD40	331	093WG401A	506	093WS76145N08	461	093WW454N10	407	094103	675
093WD4020	333	093WG401R	506	093WS76145N08R	461	093WW454N10R	407	094103	677
093WD4040	334	093WG402	508	093WS80145N08	464	093WW454N10RS	407	094103	681
093WD4080	332	093WG402N	508	093WS80145N08R	464	093WW454N10S	407	094103	682
093WD45	331	093WG402NS02	508	093WS90145N10	466	093WWC401N08S01	662	094103CS	676
093WD4590	332	093WG402NS03	508	093WS90145N10R	466	093XWWC401N08	663	094103CS	678
093WD6030	333	093WG403	509	093WU201S	364	094002CSM6	676	094103G	679
093WD6060	334	093WH400808	665	093WU302S	365	094002M4	675	094103K	688
093WD7638	333	093WI40N08S01	354	093WU302V	365	094002M5	675	094103K	689
093WD7676	334	093WK301N06A	501	093WU401S	366	094002M6	675	094105	675
093WD8040	333	093WK301N06R	501	093WU401VS01	366	094003CSM6	678	094105	677
093WD8080	334	093WK401N08A	503	093WU4060V	367	094003GM6	679	094105	681
093WD9045	333	093WK401N08R	503	093WU4080V	367	094003M4	677	094105	682
093WD9090	334	093WKWF301N06A	502	093WV1001V	363	094003M5	677	094105CS	676
093WE201N05	368	093WKWF301N06R	502	093WV1002V	363	094003M6	677	094105CS	678
093WE202N06	371	093WKWF401N08A	504	093WV1003V	362	094004CSM6	678	094105G	679
093WE301N08	377	093WKWF401N08R	504	093WV431V	360	094004M4	677	094105K	688
093WE302N06	374	093WL201N10S01	664	093WV432V	360	094004M5	677	094105K	689
093WE381N08	381	093WL201N10S04	666	093WV452V	693	094004M6	677	094202	688
093WE402N08	384	093WS20145N05	453	093WV781V	361	094005CSM6	678	094202SL	689
093WE405N10	388	093WS20145N05R	453	093WW201N05	398	094005GM6	679	094203	688
093WE452N10	391	093WS25145N6,5	456	093WW201N05S01	398	094005M4	677	094203SL	689
093WEA201A	369	093WS25145N6,5R	456	093WW201N06R	398	094005M5	677	094204	688
093WEA201B	370	093WS30145N0810RS01	467	093WW202N05	399	094005M6	677	094204SL	689
093WEA202A	372	093WS30145N0810RS02	467	093WW202N05S01	399	094008CSM6	678	094205	688
093WEA202B	373	093WS30145N0810S01	467	093WW202N06R	399	094008M4	677	094205SL	689
093WEA301A	378	093WS30145N0810S02	467	093WW251N06	400	094008M5	677	0942SL	690
093WEA301B	379	093WS30145N0810S03	467	093WW251N06S01	400	094008M6	677	094311	687
093WEA301C	380	093WS30145N0810S04	467	093WW252N06	401	094010M4	682	094411M4	674
093WEA302A	375	093WS30245N08	458	093WW252N06S01	401	094010M5	682	094500M6	684
093WEA302B	376	093WS30245N08R	458	093WW303N08	402	094010M6	682	094501M5	683
093WEA381B	382	093WS38145N08	460	093WW303N08R	402	094020CLIPM6	681	094511M5CS	685
093WEA381D	383	093WS38145N08R	460	093WW303N08RS	402	094020CSM6	678	094513M5CS	686
093WEA402A	385	093WS40145N08	462	093WW303N08S	402	094020GM6	679	094522M6CS	692
093WEA402AS01	385	093WS40145N08R	462	093WW304N08	403	094020M4	677	094523M6	691
093WEA402B	386	093WS40245	455	093WW304N08R	403	094020M5	677	094524M6	787
093WEA402D	387	093WS40245	463	093WW304N08RS	403	094020M6	677	09452RA20	691
093WEA405A	389	093WS40245R	455	093WW304N08S	403	094080CSM6	678	09452RA20	692
093WEA405B	390	093WS40245R	463	093WW405N08	404	094080M4	677	09452RA20	787
093WEA452A	392	093WS40445N05	454	093WW405N08R	404	094080M5	677	094605CSS02	680
093WEA452B	393	093WS40445N05R	454	093WW406N08	405	094080M6	677	094620CSS02	680
093WVF20401N08S01	395	093WS45145N10RS01	468	093WW406N08R	405	094100CSM6	676	094700	673
093WVF22451N10S01	396	093WS-45145N10RS01R02	468	093WW407N10	404	094100M4	675	094701	673
093WG130V	510	093WS45145N10S01	468	093WW407N10R	404	094100M5	675	094707	673
093WG301A	505	093WS45145N10S01R02	468	093WW407N10RS	404	094100M6	675	094901	674
093WG301R	505	093WS45145N10S02	468	093WW407N10S	404	094102	675	094901	687
093WG302N08	507	093WS45145N10S02R02	468	093WW408N10	405	094102	677	094902	674
093WG302N08S04	507			093WW408N10R	405	094102	681	094902	687



INDEX NACH TEILENUMMERN

PART NUMBER INDEX

094903	674	095300FN10	194	095A2540LS20	170	095A4035LS20	176	095A6040RS20	182
094903	687	095300N08	193	095A2540RS20	170	095A4035RS20	176	095A6045LS20	182
094904	674	095300N10	193	095A2545FS20	171	095A4040FS20	177	095A6045RS20	182
094904	687	095400	192	095A2545LS20	170	095A4040LS20	176	095A6050LS20	182
094AD28	786	095400N06	192	095A2545RS20	170	095A4040RS20	176	095A6050RS20	182
094Z40S	694	095400N08	192	095A2550FS20	171	095A4045FS20	177	095A6060FS20	183
094Z40S0817	694	0957101	538	095A2550LS20	170	095A4045LS20	176	095A6060LS20	182
094Z40S0817CS	695	0957201	538	095A2550RS20	170	095A4045RS20	176	095A6060RS20	182
094Z40S0840	694	0957301	538	095A2560FS20	171	095A4050FS20	177	095AH20	189
094Z40S0840CS	695	095740107xxARA-A4SR	545	095A2560LS20	170	095A4050LS20	176	095AH25	189
094Z40S1040	694	0957404	543	095A2560RS20	170	095A4050RS20	176	095AH30	189
094Z40S1040CS	695	09574040E	224	095A3025LS20	172	095A4060FS20	177	095AH38	189
094Z40SCS	695	0957405	543	095A3025RS20	172	095A4060LS20	176	095AH40	189
095004	162	0957406	543	095A3030FS20	173	095A4060RS20	176	095AH45	189
095005	196	0957408	540	095A3030LS20	172	095A4525LS20	178	095AH50	189
095006	197	0957408S01	540	095A3030RS20	172	095A4525RS20	178	095AH60	189
095007	199	0957409	546	095A3035FS20	173	095A4530LS20	178	095AI20	188
095007E	227	0957409S02	546	095A3035LS20	172	095A4530RS20	178	095AI25	188
095008	202	0957409S03	546	095A3035RS20	172	095A4535LS20	178	095AI30	188
095009	200	0957410	540	095A3040FS20	173	095A4535RS20	178	095AI38	188
095009F	210	0957410S01	540	095A3040LS20	172	095A4540LS20	178	095AI40	188
095010	198	0957411	540	095A3040RS20	172	095A4540RS20	178	095AI45	188
095010E	226	0957411S01	540	095A3045FS20	173	095A4545FS20	179	095AI50	188
095012	139	0957415	542	095A3045LS20	172	095A4545LS20	178	095AI60	188
095014	205	0957416	542	095A3045RS20	172	095A4545RS20	178	095AIA	188
095015	206	0957417	542	095A3050FS20	173	095A4550FS20	179	095AIA	189
095016	207	0957420S01	541	095A3050LS20	172	095A4550LS20	178	095AIR01	188
095017	201	0957420S02	541	095A3050RS20	172	095A4550RS20	178	095AIR01	189
095020D	164	0957431	540	095A3060FS20	173	095A4560FS20	179	095AL40N0840N08	187
095020L	163	0957432	540	095A3060LS20	172	095A4560LS20	178	095AL40N0840N08S01	187
095020R	163	0957504	547	095A3060RS20	172	095A4560RS20	178	095AN05	170
095022F00	161	0957505	547	095A3525LS20	174	095A5025LS20	180	095AN05	171
095022F05	161	09575050E	225	095A3525RS20	174	095A5025RS20	180	095AN05	172
095022F06	161	09575050ELR	229	095A3530LS20	174	095A5030LS20	180	095AN05	173
095023L	195	0957506	547	095A3530RS20	174	095A5030RS20	180	095AN05	174
095023R	195	0957601	551	095A3535FS20	175	095A5035LS20	180	095AN05	175
095027	203	09576060E	228	095A3535LS20	174	095A5035RS20	180	095AN05	176
095028	204	0957WL10	544	095A3535RS20	174	095A5040LS20	180	095AN05	177
095029	208	0957WL20	544	095A3540FS20	175	095A5040RS20	180	095AN05	178
095030	208	0957WL5	544	095A3540LS20	174	095A5045LS20	180	095AN05	179
095031	209	0957WS	544	095A3540RS20	174	095A5045RS20	180	095AN05	180
095032	209	0957WY	544	095A3545FS20	175	095A5050FS20	181	095AN05	181
095033	209	0957WY02	544	095A3545LS20	174	095A5050LS20	180	095AN05	182
095047	184	095990S	211	095A3545RS20	174	095A5050RS20	180	095AN05	183
095050	185	095A2525FS20	171	095A3550FS20	175	095A5060FS20	181	095AN06	170
095051	185	095A2525LS20	170	095A3550LS20	174	095A5060LS20	180	095AN06	171
095052	185	095A2525RS20	170	095A3550RS20	174	095A5060RS20	180	095AN06	172
095065	169	095A2530FS20	171	095A3560FS20	175	095A6025LS20	182	095AN06	173
095071	186	095A2530LS20	170	095A3560LS20	174	095A6025RS20	182	095AN06	174
095072	223	095A2530RS20	170	095A3560RS20	174	095A6030LS20	182	095AN06	175
095072S01	223	095A2535FS20	171	095A4025LS20	176	095A6030RS20	182	095AN06	176
095300	193	095A2535LS20	170	095A4025RS20	176	095A6035LS20	182	095AN06	177
095300F	194	095A2535RS20	170	095A4030LS20	176	095A6035RS20	182	095AN06	178
095300FN08	194	095A2540FS20	171	095A4030RS20	176	095A6040LS20	182	095AN06	179



INDEX NACH TEILENUMMERN

PART NUMBER INDEX

095AN06	180	095AN14	178	095K3030F06	143	095K4040F00	147	095K5050L00	150
095AN06	181	095AN14	179	095K3030F08	143	095K4040F08	147	095K5050L08	150
095AN06	182	095AN14	180	095K3030L00	142	095K4040F10	147	095K5050L10	150
095AN06	183	095AN14	181	095K3030L06	142	095K4040L00	146	095K5050R00	150
095AN08	170	095AN14	182	095K3030L08	142	095K4040L08	146	095K5050R08	150
095AN08	171	095AN14	183	095K3030R00	142	095K4040L10	146	095K5050R10	150
095AN08	172	095E2020F	212	095K3030R06	142	095K4040R00	146	095K5060F00	151
095AN08	173	095E2525F	214	095K3030R08	142	095K4040R08	146	095K5060L00	150
095AN08	174	095E2525L	213	095K3035F00	143	095K4040R10	146	095K5060R00	150
095AN08	175	095E2525R	213	095K3035L00	142	095K4045F00	147	095K6025L00	152
095AN08	176	095E3030F	216	095K3035R00	142	095K4045L00	146	095K6025R00	152
095AN08	177	095E3030L	215	095K3040F00	143	095K4045R00	146	095K6030L00	152
095AN08	178	095E3030R	215	095K3040L00	142	095K4050F00	147	095K6030R00	152
095AN08	179	095E4040F	218	095K3040R00	142	095K4050L00	146	095K6035L00	152
095AN08	180	095E4040L	217	095K3045F00	143	095K4050R00	146	095K6035R00	152
095AN08	181	095E4040R	217	095K3045L00	142	095K4060F00	147	095K6040L00	152
095AN08	182	095E4545F	220	095K3045R00	142	095K4060L00	146	095K6040R00	152
095AN08	183	095E4545L	219	095K3050F00	143	095K4060R00	146	095K6045L00	152
095AN10	170	095E4545R	219	095K3050L00	142	095K4525L00	148	095K6045R00	152
095AN10	171	095E6060F	222	095K3050R00	142	095K4525R00	148	095K6050L00	152
095AN10	172	095E6060L	221	095K3060F00	143	095K4530L00	148	095K6050R00	152
095AN10	173	095E6060R	221	095K3060L00	142	095K4530R00	148	095K6060F00	153
095AN10	174	095K2020L00	138	095K3060R00	142	095K4535L00	148	095K6060F08	153
095AN10	175	095K2020R00	138	095K3525L00	144	095K4535R00	148	095K6060F10	153
095AN10	176	095K2525F00	141	095K3525R00	144	095K4540L00	148	095K6060L00	152
095AN10	177	095K2525F06	141	095K3530L00	144	095K4540R00	148	095K6060L08	152
095AN10	178	095K2525F08	141	095K3530R00	144	095K4545F00	149	095K6060L10	152
095AN10	179	095K2525L00	140	095K3535F00	145	095K4545F08	149	095K6060R00	152
095AN10	180	095K2525L06	140	095K3535F08	145	095K4545F10	149	095K6060R08	152
095AN10	181	095K2525L08	140	095K3535F10	145	095K4545L00	148	095K6060R10	152
095AN10	182	095K2525R00	140	095K3535L00	144	095K4545L08	148	095KF2525F00	154
095AN10	183	095K2525R06	140	095K3535L08	144	095K4545L10	148	095KF2525F06	154
095AN12	170	095K2525R08	140	095K3535L10	144	095K4545R00	148	095KF2525F08	154
095AN12	171	095K2530F00	141	095K3535R00	144	095K4545R08	148	095KF3030F00	154
095AN12	172	095K2530L00	140	095K3535R08	144	095K4545R10	148	095KF3030F06	154
095AN12	173	095K2530R00	140	095K3535R10	144	095K4550F00	149	095KF3030F08	154
095AN12	174	095K2535F00	141	095K3540F00	145	095K4550L00	148	095KF3535F00	154
095AN12	175	095K2535L00	140	095K3540L00	144	095K4550R00	148	095KF3535F08	154
095AN12	176	095K2535R00	140	095K3540R00	144	095K4560F00	149	095KF3535F10	154
095AN12	177	095K2540F00	141	095K3545F00	145	095K4560L00	148	095KF4040F00	154
095AN12	178	095K2540L00	140	095K3545L00	144	095K4560R00	148	095KF4040F08	154
095AN12	179	095K2540R00	140	095K3545R00	144	095K5025L00	150	095KF4040F10	154
095AN12	180	095K2545F00	141	095K3550F00	145	095K5025R00	150	095KF4545F00	154
095AN12	181	095K2545L00	140	095K3550L00	144	095K5030L00	150	095KF4545F08	154
095AN12	182	095K2545R00	140	095K3550R00	144	095K5030R00	150	095KF4545F10	154
095AN12	183	095K2550F00	141	095K3560F00	145	095K5035L00	150	095KF5050F00	154
095AN14	170	095K2550L00	140	095K3560L00	144	095K5035R00	150	095KF5050F08	154
095AN14	171	095K2550R00	140	095K3560R00	144	095K5040L00	150	095KF5050F10	154
095AN14	172	095K2560F00	141	095K4025L00	146	095K5040R00	150	095KF6060F00	154
095AN14	173	095K2560L00	140	095K4025R00	146	095K5045L00	150	095KF6060F08	154
095AN14	174	095K2560R00	140	095K4030L00	146	095K5045R00	150	095KF6060F10	154
095AN14	175	095K3025L00	142	095K4030R00	146	095K5050F00	151	095KS3030F00	165
095AN14	176	095K3025R00	142	095K4035L00	146	095K5050F08	151	095KS3030F08	165
095AN14	177	095K3030F00	143	095K4035R00	146	095K5050F10	151	095KS3040F00	165



INDEX NACH TEILENUMMERN

PART NUMBER INDEX

095KS3040F08	165	095Z4545F08S	190	096028	261	096125FE	272	096244F	240
095KS3040F0810	165	095Z4545F10S	190	096028E	261	096126	271	096245F	240
095KS3040F0810S01	165	095ZF4040F00S	191	096028F	262	096126E	271	096264	239
095KS3045F00	165	095ZF4040F08S	191	096028S01	261	096126F	272	096265	239
095KS3045F0810	165	095ZF4040F10S	191	09602U10-32	261	096126FE	272	096274	249
095KS3045F0810S02	165	095ZF4045F00S	191	096030.1500	281	096128	271	096275	249
095KS3060F00	165	095ZF4045F08S	191	096030S06	283	096128E	271	096276	249
095KS3060F0810	165	095ZF4045F10S	191	096030S07	283	096128F	272	096280.1500	245
095KS3060F0810S01	165	095ZF4545F00S	191	096030S08	283	096128FE	272	096284	245
095KS4040F00	166	095ZF4545F08S	191	096030S09	283	096130.1500	278	096284F	246
095KS4040F08	166	095ZF4545F10S	191	096030S38	513	096134	278	096285	245
095KS4040F0810	166	096000.1500	263	096030S41	118	096135	278	096285F	246
095KS4040F10	166	096000E.1500	263	096034	281	096136	278	096286	245
095KS4040F10S01	166	096000S83	359	096035	281	096138	278	096286F	246
095KS4045F00	166	096003	263	096036	281	096145F	286	096310.1500	253
095KS4045F0810	166	096003E	263	096038	281	096146F	286	096314	253
095KS4045F10	166	096004	263	096060.1500	266	096148F	286	096314F	254
095KS4060F00	166	096004E	263	096060S13	514	096160.1500	269	096315	253
095KS4060F0810	166	096004S01	263	096060S54	118	096164	269	096315F	254
095KS4060F10	166	096005	263	096064	266	096164F	270	096316	253
095KS4545F00	167	096005E	263	096065	266	096165	269	096316F	254
095KS4545F10	167	096005S01	263	096066	266	096165F	270	096318	253
095KS4545F10S03	167	096006	263	096066E	266	096166	269	096318F	254
095KS4560F00	167	096006D36	432	096068	266	096166F	270	096320.1500	258
095KS4560F10	167	096006D76	432	096068E	266	096168	269	096324	258
095KS4560F10S01	167	096006E	263	096070.1500	287	096168F	270	096325	258
095KS6060F00	168	096006S01	263	096074	287	09616U10-32	269	096326	258
095KS6060F10	168	096008	263	096075	287	09616U10-32F	270	096328	258
095KS6060F10S01	168	096008D36	427	096076	287	096176	288	096330.1500	260
095S3030A00	155	096008D76	427	096077	287	096178	288	096334	260
095S3030A06	155	096008E	263	096078	287	096178.1500	288	096335	260
095S3030A08	155	096008S01	263	096080.1500	273	096200.1500	238	096335E	260
095S4040A00	156	096008U10-32	263	096083	273	096203	238	096336	260
095S4040A08	156	096010.1500	264	096084	273	096204	238	096336E	260
095S4040A10	156	096010S05	511	096084F	274	096204E	238	096338	260
095SF3030A00	159	096010S11	512	096085	273	096205	238	096338E	260
095SF3030A06	159	096010S46	511	096085F	274	096205E	238	096348	275
095SF3030A08	159	096014	264	096086	273	096210.1500	237	096355	276
095SF4040A00	160	096015	264	096086F	274	096213	237	096356	276
095SF4040A08	160	096016	264	096088	273	096214	237	096358	276
095SF4040A10	160	096018	264	096088F	274	096215	237	096395	282
095SR3030A00	157	096020.1500	261	096095	259	096230.1500	241	096396	282
095SR3030A06	157	096023	261	096096	259	096233	241	096396E	282
095SR3030A08	157	096024	261	096098	259	096234	241	096398	282
095SR4040A00	158	096024F	262	096110.1500	267	096235	241	096398E	282
095SR4040A08	158	096024S01	261	096115	267	096235D28	244	096400.1500	256
095SR4040A10	158	096025	261	096116	267	096235D28S01	244	096404	256
095Z4040F00S	190	096025E	261	096118	267	096235D58	244	096405	256
095Z4040F08S	190	096025F	262	096120.1500	271	096235D58S01	244	096406	256
095Z4040F10S	190	096025S01	261	096120E.1500	271	096235E	241	096406F	257
095Z4045F00S	190	096026	261	096124	271	096235S01	241	096408	256
095Z4045F08S	190	096026E	261	096124E	271	096236	241	096424	250
095Z4045F10S	190	096026F	262	096125	271	096236D28	244	096424F	251
095Z4545F00S	190	096026S01	261	096125E	271	096236D58	244	096424FE	251
				096125F	272	096236E	241		



INDEX NACH TEILENUMMERN

PART NUMBER INDEX

096425	250	0969810	289	096HK0815M0825	298	096P0151004M6	308	098A050KG	45
096425F	251	0969812	289	096HK0815M0830	298	096P0151005M6	308	098A050ZS	47
096425FE	251	096986	289	096HK0830M0620	298	096P0191604M4	308	098A060E	49
096426	250	096988	289	096HK0830M0625	298	096P0191604M5	308	098A060EG	49
096426F	251	096F0804	302	096HK0830M0630	298	096P0191604M6	308	098A060K	45
096426FE	251	096F0805	302	096HK0830M0640	298	096P0191604M8	308	098A060KG	45
096428	250	096F0806	302	096HK0830M0660	298	096P0191904M4	308	098A060ZBS	48
096428F	251	096F1004	303	096HK0830M0820	298	096P0191904M5	308	098A060ZBSG	48
096428FE	251	096F1005	303	096HK0830M0825	298	096P0191904M6	308	098A060ZS	47
096448	279	096F1006	303	096HK0830M0830	298	096P0191904M8	308	098A060ZSG	47
096450.1500	268	096F1008	303	096HK0830M0840	298	096P0201305M6	309	098A080E	49
096455	268	096FN08	291	096HK1015M0620	299	096P0201305M8	309	098A080EB	50
096456	268	096FN10	291	096HK1015M0625	299	096P0201406M8	309	098A080EBG	50
096458	268	096H06410	293	096HK1015M0630	299	096P0201806M8	309	098A080EG	49
096466	255	096H06410E	293	096HK1015M0640	299	096P0202004M4	309	098A080K	45
096468	255	096H0810-3215	295	096HK1015M0660	299	096P0202004M5	309	098A080KB	46
096484E	248	096H08415	295	096HK1015M0820	299	096P0202004M6	309	098A080KBG	46
096485E	248	096H08430	295	096HK1015M0825	299	096P0202006M5	309	098A080KBZ	46
096494F	252	096H08515	295	096HK1015M0830	299	096P0202006M6	309	098A080KBZG	46
096495F	252	096H08530	295	096HK1015M0840	299	096P0202006M8	309	098A080KG	45
096496F	252	096H08610	294	096HK1015M0860	299	096P0221505M6	309	098A080ZBS	48
096498F	252	096H08615	295	096HK1030M0620	299	096P0251205M6	309	098A080ZBSG	48
096504	247	096H08615E	295	096HK1030M0620E	300	096P0301808M8	309	098A080ZS	47
096505	247	096H08630	295	096HK1030M0625	299	096P0302006M10	309	098A080ZSG	47
096506	247	096H1010-3230	296	096HK1030M0625E	300	096P0302505M8	309	098A100E	49
096523	236	096H10413S02	296	096HK1030M0630	299	096P0302506M8	309	098A100EB	50
096524	236	096H10430	296	096HK1030M0630E	300	096P0323008M8	309	098A100EBG	50
096525	236	096H10513S02	296	096HK1030M0640	299	096P0353005M6	309	098A100EG	49
0965310	280	096H10517	296	096HK1030M0640E	300	096P0434305M8	309	098A100K	45
096538	280	096H10530	296	096HK1030M0660	299	096PR0191305M8	310	098A100KB	46
096550.1500	242	096H10613S02	296	096HK1030M0660E	300	096PR0201304M6	310	098A100KBG	46
096553	242	096H10617	296	096HK1030M0820	299	096PR0231506M8	310	098A100KBZ	46
096554	242	096H10630	296	096HK1030M0820E	300	096R080318Z	307	098A100KBZG	46
096555	242	096H10630E	297	096HK1030M0825	299	096R080329Z	306	098A100KG	45
096555D28	243	096H10630ES03	297	096HK1030M0825E	300	096R080330Z	307	098A100ZBS	48
096555D58	243	096H10630ES04	297	096HK1030M0830	299	096R080418Z	307	098A100ZBSG	48
096556	242	096H10813S02	296	096HK1030M0830E	300	096R080429Z	306	098A100ZS	47
096556D28	243	096H10817	296	096HK1030M0840	299	096R080430Z	307	098A100ZSG	47
096556D58	243	096H10830	296	096HK1030M0840E	300	096R080518Z	307	098A120E	49
096560.1500	265	096H10830E	297	096HK1030M0860	299	096R080529Z	306	098A120EB	50
096565	265	096H10830ES03	297	096HK1030M0860E	300	096R080530Z	307	098A120EBG	50
096566	265	096H10830ES07	297	096HK1045M0820	299	096R080629Z	306	098A120EG	49
096568	265	096HK0815M0616	298	096HK1045M0825	299	096R404F	305	098A120ZBS	48
0966710S01	290	096HK0815M0620	298	096HK1045M0830	299	096R405F	305	098A120ZBSG	48
096676S01	290	096HK0815M0620E	298	096P0090903M4	308	096R406F	305	098A120ZS	47
096678S02	290	096HK0815M0625	298	096P0090903M5	308	096R424F	304	098A120ZSG	47
096928	277	096HK0815M0625E	298	096P0090903M6	308	096R425F	304	098AA080ZS	52
096930S02	285	096HK0815M0630	298	096P01409025M4	308	096R426F	304	098AA080ZSG	52
096930S03	285	096HK0815M0630E	298	096P01409025M5	308	096SM10M04	311	098ABG045	64
096930S04	285	096HK0815M0640	298	096P0141203M4	308	096SM10M05	311	098ABG045S01	64
096930S05	285	096HK0815M0640E	298	096P0141203M5	308	096SM10M06	311	098ABG060	64
096930S06	284	096HK0815M0660	298	096P0141203M6	308	098A040ZS	47	098ABG060S01	64
096930S07	284	096HK0815M0660E	298	096P0151004M4	308	098A045ZS	47	098ABG090	64
096930S08	284	096HK0815M0820	298	096P0151004M5	308	098A050K	45	098ABG090S01	64



INDEX NACH TEILENUMMERN

PART NUMBER INDEX

098AG050	60	098AM24150E	57	098AV080ZSG	53	098CM24150E	40	098D080KBG	17
098AG060	60	098AM24150M	56	098AV100ZS	53	098CM24150M	39	098D080KBZ	17
098AG060B	60	098AM24200E	57	098AV100ZSG	53	098CM24200E	40	098D080KBZG	17
098AG060S01	60	098AM24200M	56	098AVG060	61	098CM24200M	39	098D080KKG	16
098AG080	60	098AM24300E	57	098AVG080	61	098CM24250E	40	098D080ZBS	19
098AG080B	60	098AM24300M	56	098AVG100	61	098CM24250M	39	098D080ZBSG	19
098AG100B	60	098AM30100E	57	098BI060ZS	55	098CM30100E	40	098D080ZS	18
098AG120B	60	098AM30100M	56	098BI080ZS	55	098CM30100M	39	098D080ZSG	18
098AG125B	44	098AM30150E	57	098C060K	36	098CM30150E	40	098D100E	20
098AG125B	62	098AM30150M	56	098C060KKG	36	098CM30150M	39	098D100EB	21
098AG125B	74	098AM30200E	57	098C080K	36	098CM30200E	40	098D100EBG	21
098AG175B	44	098AM30200M	56	098C080KB	37	098CM30200M	39	098D100EG	20
098AG175B	62	098AM30250E	57	098C080KBG	37	098CM30250E	40	098D100K	16
098AG175B	74	098AM30250M	56	098C080KBZ	37	098CM30250M	39	098D100KB	17
098AI060ZS	51	098AM30300E	57	098C080KBZG	37	098CM30300E	40	098D100KBG	17
098AI060ZSG	51	098AM30300M	56	098C080KKG	36	098CM30300M	39	098D100KBZ	17
098AI080ZS	51	098AU1-4E	59	098C100K	36	098D030E	20	098D100KBZG	17
098AI080ZSG	51	098AU1-4M	58	098C100KB	37	098D030EG	20	098D100KKG	16
098AK125KBZ	54	098AU1-6E	59	098C100KBG	37	098D030K	16	098D100ZBS	19
098AK125KBZG	54	098AU1-6M	58	098C100KBZ	37	098D030KKG	16	098D100ZBSG	19
098AK175KBZ	54	098AU1-8E	59	098C100KBZG	37	098D030ZS	18	098D100ZS	18
098AK175KBZG	54	098AU1-8M	58	098C100KKG	36	098D030ZSG	18	098D100ZSG	18
098AM12066E	57	098AU1/2-3E	59	098CK125KBZ	38	098D040E	20	098D120E	20
098AM12066M	56	098AU1/2-3M	58	098CK125KBZG	38	098D040EG	20	098D120EB	21
098AM12100E	57	098AU1/2-4E	59	098CK175KBZ	38	098D040K	16	098D120EBG	21
098AM12100M	56	098AU1/2-4M	58	098CK175KBZG	38	098D040KKG	16	098D120EG	20
098AM12125E	57	098AU1/2-5E	59	098CM16066E	40	098D040ZS	18	098D120KB	17
098AM12125M	56	098AU1/2-5M	58	098CM16066M	39	098D040ZSG	18	098D120KBG	17
098AM12150E	57	098AU1/2-6E	59	098CM16100E	40	098D045E	20	098D120KBZ	17
098AM12150M	56	098AU1/2-6M	58	098CM16100M	39	098D045EG	20	098D120KBZG	17
098AM16066E	57	098AU11/4-4E	59	098CM16125E	40	098D045K	16	098D120ZBS	19
098AM16066M	56	098AU11/4-6E	59	098CM16125M	39	098D045KKG	16	098D120ZBSG	19
098AM16100E	57	098AU11/4-8E	59	098CM16150E	40	098D045ZS	18	098D120ZS	18
098AM16100M	56	098AU3/4-4E	59	098CM16150M	39	098D045ZSG	18	098D120ZSG	18
098AM16125E	57	098AU3/4-4M	58	098CM16200E	40	098D050E	20	098DA040K	23
098AM16125M	56	098AU3/4-5E	59	098CM16200M	39	098D050EG	20	098DA040KKG	23
098AM16150E	57	098AU3/4-5M	58	098CM20085E	40	098D050K	16	098DA060K	24
098AM16150M	56	098AU3/4-6E	59	098CM20085M	39	098D050KKG	16	098DA080K	25
098AM16200E	57	098AU3/4-6M	58	098CM20100E	40	098D050ZS	18	098DA080KKG	25
098AM16200M	56	098AU3/4-8E	59	098CM20100M	39	098D050ZSG	18	098DA080ZS	26
098AM16250E	57	098AU3/4-8M	58	098CM20125E	40	098D060E	20	098DA080ZSG	26
098AM16250M	56	098AU5/8-3E	59	098CM20125M	39	098D060EG	20	098DAG060	42
098AM20100E	57	098AU5/8-3M	58	098CM20150E	40	098D060K	16	098DE060EG	22
098AM20100M	56	098AU5/8-4E	59	098CM20150M	39	098D060KKG	16	098DE080EG	22
098AM20125E	57	098AU5/8-4M	58	098CM20200E	40	098D060ZBS	19	098DE100EG	22
098AM20125M	56	098AU5/8-5E	59	098CM20200M	39	098D060ZBSG	19	098DG030	41
098AM20150E	57	098AU5/8-5M	58	098CM20250E	40	098D060ZS	18	098DG040	41
098AM20150M	56	098AU5/8-6E	59	098CM20250M	39	098D060ZSG	18	098DG040B	41
098AM20200E	57	098AU5/8-6M	58	098CM24085E	40	098D080E	20	098DG045	41
098AM20200M	56	098AU5/8-8E	59	098CM24085M	39	098D080EB	21	098DG050	41
098AM20250E	57	098AU5/8-8M	58	098CM24100E	40	098D080EBG	21	098DG060	41
098AM20250M	56	098AV060ZS	53	098CM24100M	39	098D080EG	20	098DG060B	41
098AM24100E	57	098AV060ZSG	53	098CM24125E	40	098D080K	16	098DG080	41
098AM24100M	56	098AV080ZS	53	098CM24125M	39	098D080KB	17	098DG080B	41



INDEX NACH TEILENUMMERN

PART NUMBER INDEX

098DG100B	41	098DM20125E	32	098DVG060	43	098EM10100E	69	098F100TNESD	126
098DG120B	41	098DM20125M	30	098DVG080	43	098EM10100M	68	098F100U4045N	127
098DI060ZS	27	098DM20150E	32	098DVG100	43	098EM10120E	69	098F100U4045NESD	127
098DI060ZSG	27	098DM20150M	30	098E030E	67	098EM10120M	68	098F100UN	126
098DI080ZS	27	098DM20200E	32	098E030EG	67	098EM12025E	69	098F100UNESD	126
098DI080ZSG	27	098DM20200M	30	098E030K	65	098EM12025M	68	098F125A4045N	127
098DM08025E	31	098DM20250E	32	098E030KG	65	098EM12040E	69	098F125AN	126
098DM08025M	29	098DM20250M	30	098E030ZS	66	098EM12040M	68	098F125G4045N	127
098DM08040E	31	098DM24085E	32	098E030ZSG	66	098EM12050E	69	098F125G4045NESD	127
098DM08040M	29	098DM24085M	30	098E030ZV	66	098EM12050M	68	098F125GN	126
098DM08080E	31	098DM24100E	32	098E030ZVG	66	098EM12070E	69	098F125GNESD	126
098DM08080M	29	098DM24100M	30	098E040E	67	098EM12070M	68	098F125T4045N	127
098DM10045E	31	098DM24125E	32	098E040EG	67	098EM12080E	69	098F125T4045NESD	127
098DM10045M	29	098DM24125M	30	098E040K	65	098EM12080M	68	098F125TN	126
098DM10070E	31	098DM24150E	32	098E040KG	65	098EM12100E	69	098F125TNESD	126
098DM10070M	29	098DM24150M	30	098E040ZS	66	098EM12100M	68	098F125U4045N	127
098DM10090E	31	098DM24200E	32	098E040ZSG	66	098EM12120E	69	098F125U4045NESD	127
098DM10090M	29	098DM24200M	30	098E040ZV	66	098EM12120M	68	098F125UN	126
098DM10125E	31	098DM24250E	32	098E040ZVG	66	098EM16040E	69	098F125UNESD	126
098DM10125M	29	098DM24250M	30	098E050E	67	098EM16040M	68	098F16070A	75
098DM10150E	31	098DSW14M06E	35	098E050EG	67	098EM16050E	69	098F16E	77
098DM10150M	29	098DSW14M06M	35	098E050K	65	098EM16050M	68	098F16M	77
098DM12045E	31	098DSW14M08E	35	098E050KG	65	098EM16070E	69	098F20090A	76
098DM12045M	29	098DSW14M08M	35	098E050ZS	66	098EM16070M	68	098F20E	77
098DM12066E	31	098DSW14U1/4E	35	098E050ZSG	66	098EM16100E	69	098F20M	77
098DM12066M	29	098DSW14U1/4M	35	098E050ZV	66	098EM16100M	68	098G38150A	117
098DM12100E	31	098DU1-4M	33	098E050ZVG	66	098EM16150E	69	098G40150A	117
098DM12100M	29	098DU1-5M	33	098EG030	70	098EM16150M	68	098G45150A	117
098DM12125E	31	098DU1-6M	33	098EG040	70	098F01	76	098G4560X120A	119
098DM12125M	29	098DU1-8M	33	098EG050	70	098F01	78	098G4560X135A	121
098DM12150E	31	098DU1/4-1,5E	34	098EM08025E	69	098F01	79	098G4590X150A	120
098DM12150M	29	098DU3/4-3M	33	098EM08025M	68	098F080A4045N	127	098H300606	82
098DM14066E	31	098DU3/4-4M	33	098EM08040E	69	098F080AN	126	098H300808	82
098DM14066M	29	098DU3/4-5M	33	098EM08040M	68	098F080G4045N	127	098H350808	82
098DM14100E	31	098DU3/4-6,5M	33	098EM08050E	69	098F080G4045NESD	127	098H351008	82
098DM14100M	29	098DU3/4-6M	33	098EM08050M	68	098F080GN	126	098H400808	82
098DM14125E	31	098DU3/4-8M	33	098EM08070E	69	098F080GNESD	126	098H401008	82
098DM14125M	29	098DU3/4-9,5M	33	098EM08070M	68	098F080T4045N	127	098H450808	82
098DM14150E	31	098DU3/8-1,5E	34	098EM08080E	69	098F080T4045NESD	127	098H451008	82
098DM14150M	29	098DU3/8-2,5E	34	098EM08080M	68	098F080TN	126	098H500808	82
098DM16066E	31	098DU3/8-2E	34	098EM08100E	69	098F080TNESD	126	098H501008	82
098DM16066M	29	098DU3/8-3E	34	098EM08100M	68	098F080U4045N	127	098K125KBZ	71
098DM16100E	31	098DU3/8-4E	34	098EM08120E	69	098F080U4045NESD	127	098K125KBZG	71
098DM16100M	29	098DU3/8-5E	34	098EM08120M	68	098F080UN	126	098K175KBZ	71
098DM16125E	31	098DU3/8-6E	34	098EM10025E	69	098F080UNESD	126	098K175KBZG	71
098DM16125M	29	098DU5/16-1,5E	34	098EM10025M	68	098F100A4045N	127	098KM16100E	73
098DM16150E	31	098DU5/16-2,5E	34	098EM10040E	69	098F100AN	126	098KM16100M	72
098DM16150M	29	098DU5/16-3,5E	34	098EM10040M	68	098F100G4045N	127	098KM16150E	73
098DM16200E	31	098DV060ZS	28	098EM10050E	69	098F100G4045NESD	127	098KM16150M	72
098DM16200M	29	098DV060ZSG	28	098EM10050M	68	098F100GN	126	098KM16200E	73
098DM20085E	32	098DV080ZS	28	098EM10070E	69	098F100GNESD	126	098KM16200M	72
098DM20085M	30	098DV080ZSG	28	098EM10070M	68	098F100T4045N	127	098KM20100E	73
098DM20100E	32	098DV100ZS	28	098EM10080E	69	098F100T4045NESD	127	098KM20100M	72
098DM20100M	30	098DV100ZSG	28	098EM10080M	68	098F100TN	126	098KM20150E	73



INDEX NACH TEILENUMMERN

PART NUMBER INDEX

098KM20150M	72	098S080UD4045N	125	098V402508	84	098V604010	86	098VR422514	90
098KM20200E	73	098S080UD4045NESD	125	098V402510	84	098V604012	86	098VR422516	90
098KM20200M	72	098S080UDN	124	098V402512	84	098V604014	86	098VR422520	90
098KM24100E	73	098S080UDNESD	124	098V402514	84	098V604016	86	098VR481512	91
098KM24100M	72	098S100AD4045N	125	098V402516	84	098V604020	86	098VR481514	91
098KM24150E	73	098S100ADN	124	098V402520	84	098VE50302008	87	098VR481516	91
098KM24150M	72	098S100GD4045N	125	098V403008	84	098VE50302010	87	098VR481520	91
098KM24200E	73	098S100GD4045NESD	125	098V403010	84	098VE50302012	87	098VR482012	91
098KM24200M	72	098S100GDN	124	098V403012	84	098VE50302014	87	098VR482014	91
098KM30100E	73	098S100GDNESD	124	098V403014	84	098VE50302016	87	098VR482016	91
098KM30100M	72	098S100TD4045N	125	098V403016	84	098VR301008	88	098VR482020	91
098KM30150E	73	098S100TD4045NESD	125	098V403020	84	098VR301010	88	098VR482512	91
098KM30150M	72	098S100TDN	124	098V404008	84	098VR301012	88	098VR482514	91
098KM30200E	73	098S100TDNESD	124	098V404010	84	098VR301014	88	098VR482516	91
098KM30200M	72	098S100UD4045N	125	098V404012	84	098VR301016	88	098VR482520	91
098M020K	13	098S100UD4045NESD	125	098V404014	84	098VR301508	88	098VR511512	92
098M020KG	13	098S100UDN	124	098V404016	84	098VR301510	88	098VR511514	92
098M025K	13	098S100UDNESD	124	098V404020	84	098VR301512	88	098VR511516	92
098M025KG	13	098S125AD4045N	125	098V501510	85	098VR301514	88	098VR511520	92
098M030K	13	098S125ADN	124	098V501512	85	098VR301516	88	098VR512012	92
098M030KG	13	098S125GD4045N	125	098V501514	85	098VR302008	88	098VR512014	92
098M040K	13	098S125GD4045NESD	125	098V501516	85	098VR302010	88	098VR512016	92
098M040KG	13	098S125GDN	124	098V501520	85	098VR302012	88	098VR512020	92
098MG020	15	098S125GDNESD	124	098V502008	85	098VR302014	88	098VR512512	92
098MG025	15	098S125TD4045N	125	098V502010	85	098VR302016	88	098VR512514	92
098MG030	15	098S125TD4045NESD	125	098V502012	85	098VR302508	88	098VR512516	92
098MG040	15	098S125TDN	124	098V502014	85	098VR302510	88	098VR512520	92
098MM05020M	14	098S125TDNESD	124	098V502016	85	098VR302512	88	098VR602012	93
098MM05040M	14	098S125UD4045N	125	098V502020	85	098VR302514	88	098VR602014	93
098MM05060M	14	098S125UD4045NESD	125	098V502510	85	098VR302516	88	098VR602016	93
098MM06020M	14	098S125UDN	124	098V502512	85	098VR381510	89	098VR602020	93
098MM06040M	14	098S125UDNESD	124	098V502514	85	098VR381512	89	098VR602512	93
098MM06060M	14	098V301508	83	098V502516	85	098VR381514	89	098VR602514	93
098MM06080M	14	098V301510	83	098V502520	85	098VR381516	89	098VR602516	93
098MM08020M	14	098V301512	83	098V503010	85	098VR382010	89	098VR602520	93
098MM08040M	14	098V301514	83	098V503012	85	098VR382012	89	098VR603012	93
098MM08060M	14	098V301516	83	098V503014	85	098VR382014	89	098VR603014	93
098MM08080M	14	098V302008	83	098V503016	85	098VR382016	89	098VR603016	93
098MM08100M	14	098V302010	83	098V503020	85	098VR382510	89	098VR603020	93
098MM10020M	14	098V302012	83	098V504010	85	098VR382512	89	098VR604012	93
098MM10040M	14	098V302014	83	098V504012	85	098VR382514	89	098VR604014	93
098MM10060M	14	098V302016	83	098V504014	85	098VR382516	89	098VR604016	93
098MM10080M	14	098V401508	84	098V504016	85	098VR421510	90	098VR604020	93
098MM10100M	14	098V401510	84	098V504020	85	098VR421512	90	099A0520	426
098S080AD4045N	125	098V401512	84	098V602010	86	098VR421514	90	099A0520S01	426
098S080ADN	124	098V401514	84	098V602012	86	098VR421516	90	099A0520S02	429
098S080GD4045N	125	098V401516	84	098V602014	86	098VR421520	90	099A0630	426
098S080GD4045NESD	125	098V401520	84	098V602016	86	098VR422010	90	099A0630S01	426
098S080GDN	124	098V402008	84	098V602020	86	098VR422012	90	099A0630S03	429
098S080GDNESD	124	098V402010	84	098V603010	86	098VR422014	90	099A0830	426
098S080TD4045N	125	098V402012	84	098V603012	86	098VR422016	90	099A0830S01	426
098S080TD4045NESD	125	098V402014	84	098V603014	86	098VR422020	90	099A0840	426
098S080TDN	124	098V402016	84	098V603016	86	098VR422510	90	099A0840S01	426
098S080TDNESD	124	098V402020	84	098V603020	86	098VR422512	90	099A0840S02	429



INDEX NACH TEILENUMMERN

PART NUMBER INDEX

099A0840W45	519	099H052	437	099H103M8ESD	441	340ME201	94	6APR2891I.6000	620
099F0840S07	447	099H052D20	439	099H104	437	340ME467	397	6APR2891I.xxxx	620
099F0840SM08	448	099H052D20ESD	439	099H104ESD	437	4DIN439BM10E	80	6APR2891IESD.6000	620
099F0840SS07	448	099H052ESD	437	099H104M8ESD	441	4DIN439BM10M	80	6APR2891IESD.xxxx	620
099F1045S11	449	099H053	437	099HA081E	442	4DIN439BM12E	80	6APR28F74B.6000	621
099F1045S13	449	099H054	437	099HS053M4	441	4DIN439BM12M	80	6APR28F74B.xxxx	621
099G051	430	099H054D20	439	099HS061M6	441	4DIN439BM14E	80	6APR28F74I.6000	621
099G051E	431	099H054D20ESD	439	099HS081M8	441	4DIN439BM14M	80	6APR28F74I.xxxx	621
099G051M4	434	099H054D40	439	099HS083M6	441	4DIN439BM16E	80	6APR28F91B.xxxx	621
099G051M4E	435	099H054ESD	437	099HS101M8	441	4DIN439BM16M	80	6APR28F91BESD.6000	621
099G061	430	099H054M4ESD	441	099HS102M8	441	4DIN439BM20E	80	6APR28F91BESD.xxxx	621
099G061E	431	099H061	437	099HT25	443	4DIN439BM20M	80	6APR28F91I.xxxx	621
099G061M5	434	099H062	437	099HT40	443	4DIN439BM24E	80	6APR28F91IESD.6000	621
099G061M5E	435	099H062ESD	437	099HT45	443	4DIN439BM24M	80	6APR28F91IESD.xxxx	621
099G081	430	099H062M6ESD	441	099HT50	443	4DIN439BM30E	80	6MHM75100D40	579
099G081D40	433	099H081 **	437	099HT50L	443	4DIN439BM30M	80	6MHM75100S40	577
099G081D40ESD	433	099H081E	438	099I9006	450	4DIN439BM5E	80	6MPR2874.4500	619
099G081D80	433	099H081L* **	437	099I9008	451	4DIN439BM5M	80	6MPR2874.xxxx	619
099G081D80ESD	433	099H082	437	099I9008M	451	4DIN439BM6E	80	6MPR2891.4500	619
099G081E	431	099H083	437	099I9010	451	4DIN439BM6M	80	6MPR2891.xxxx	619
099G081M6	434	099H084	437	099I9010M	451	4DIN439BM8E	80	6MPR2891ESD.4500	619
099G081M6E	435	099H085 **	437	099I90R06	452	4DIN439BM8M	80	6MPR2891ESD.xxxx	619
099G084	430	099H085D40	439	099I90R06M	452	4DIN6923M06E	301	6MPR28F74.4500	619
099G084M5	434	099H085D40ESD	439	099I90R08	452	4DIN6923M06M	301	6MPR28F74.xxxx	619
099G102	430	099H085D80	439	099I90R08M	452	4DIN6923M08ES02	301	6MPR28F91.xxxx	619
099G102M6	434	099H085D80ESD	439	099I90R10	452	4DIN7991M0416M	739	6MPR28F91IESD.4500	619
099G103	430	099H085E	438	099I90R10M	452	4DIN934M10E	81	6MPR28F91IESD.xxxx	619
099G103M6	434	099H085ED40	440	099RV28180S01	782	4DIN934M10M	81	9AB045M12085MN	63
099G121	430	099H085ED40ESD	440	099RV2845S01	778	4DIN934M12E	81	9AB045M12160MN	63
099GA081K	436	099H085ED80	440	099RV2890LS01	770	4DIN934M12M	81	9AB045M16145MN	63
099GS051	430	099H085ED80ESD	440	099RV2890QS01	773	4DIN934M14E	81	9AB060M12085MN	63
099GS051E	431	099H085EESD	438	099RV28AS01	768	4DIN934M14M	81	9AB090M16085MN	63
099GS051M4	434	099H085ESD **	437	099RV28CC01	769	4DIN934M16E	81	9AB090M16145MN	63
099GS051M4E	435	099H085L* **	437	099RV28CC02	769	4DIN934M16M	81	9AB090M16200MN	63
099GS061	430	099H085LES* **	437	099RV28ES01	772	4DIN934M20E	81	9F16070A16100E	79
099GS061E	431	099H085M8ESD	441	099RV28H	783	4DIN934M20M	81	9F16070A16100M	78
099GS061M5	434	099H086	437	099RV28KS01	779	4DIN934M24E	81	9F16070A16150E	79
099GS061M5E	435	099H086D40	439	099RV28KS02	774	4DIN934M24M	81	9F16070A16150M	78
099GS081	430	099H086D40ESD	439	099RV28PS01	781	4DIN934M30E	81	9F16070A16200E	79
099GS081E	431	099H086D80	439	099RV28TS01	771	4DIN934M30M	81	9F16070A16200M	78
099GS081M6	434	099H086D80ESD	439	099RV28TWS01	777	4DIN934M5E	81	9F16070A16250E	79
099GS081M6E	435	099H086ESD	437	099RV28XS01	780	4DIN934M5M	81	9F16070A16250M	78
099GS084	430	099H087	437	099RVAP40S01	775	4DIN934M6E	81	9F16070A16300E	79
099GS084M5	434	099H087D30	439	099RVAP45S01	775	4DIN934M6M	81	9F16070A16300M	78
099GS102	430	099H087D30ESD	439	099SV45	469	4DIN934M8E	81	9F20090A20150E	79
099GS102M6	434	099H087D60	439	099ZV0830	410	4DIN934M8M	81	9F20090A20150M	78
099GS103	430	099H087D60ESD	439	12093B65	529	6APR2874B.6000	620	9F20090A20200E	79
099GS103M6	434	099H087ESD	437	12117B85	529	6APR2874B.xxxx	620	9F20090A20200M	78
099GS121	430	099H087M6ESD	441	12132B85	529	6APR2874I.6000	620	9F20090A20250E	79
099GV0845	521	099H088	437	12179B85	529	6APR2874I.xxxx	620	9F20090A20250M	78
099GV0890	520	099H101	437	340ME110	757	6APR2891B.6000	620	9F20090A20300E	79
099GV1045	521	099H102	437	340ME111	757	6APR2891B.xxxx	620	9F20090A20300M	78
099GV1090	520	099H103	437	340ME112	757	6APR2891BESD.6000	620	9F20090A20400E	79
099H051	437	099H103ESD	437	340ME154	301	6APR2891BESD.xxxx	620	9F20090A20400M	78

FATH Components

Themenkatalog Maschinenbaukomponenten 18

1. Auflage, Februar 2018

© **FATH** GmbH, D-91174 Spalt, Germany

Nachdruck oder sonstige Vervielfältigung, auch auszugsweise, nur mit ausdrücklicher Genehmigung der FATH GmbH.

Technische Änderungen vorbehalten. Alle Angaben ohne Gewähr.

Zeichnungen und Modelle sind urheberrechtlich geschützt.

Es gelten unsere aktuellen Allgemeinen Verkaufs-, Lieferungs- und Zahlungsbedingungen.

Reprinting or other duplication, including excerpts, is possible only with the express permission of FATH GmbH.

We reserve the right to make technical modifications at any time. All indications are without guarantee.

Drawings and models are the intellectual property of FATH GmbH.

Our current Terms and Conditions of Sale, Delivery and Payment apply.

PIM Programmierung: Dr. Frank Schütz

Konzept und Design: Christoph Reichelt, Dipl. Industrial Designer

Illustrationen: Andreas Teindl, Dipl. Designer, Illustrator IO

www.fath.net

simply
practical



- 1 Bodenelemente
Floor Elements
- 2 Scharniere
Hinges
- 3 Nutmuttern und -schrauben
T-Nuts and T-Bolts
- 4 Verbindungstechnik
Connecting Systems
- 5 Griffe und Verschlüsse
Handles and Latches
- 6 Arbeitsplatzkomponenten
Components for Work Stations
- 7 Gleiter und Rollen
Sliders and Rollers
- 8 Fördertechnik
Conveyors
- 9 Schutz- und Trennwandelemente
Enclosures, Guards, Partitions
- 10 Flächenbefestigungen
Panel Fasteners
- 11 Abdeckelemente
Cover Elements
- 12 Kabelführungen
Cable Management
- 13 Diverse Komponenten
Miscellaneous Components
- 14 Rundrohrkomponenten
Tubular Frame Components

Hauptsitz:
FATH GmbH
 Components
 Gewerbepark Hügelmühle 31
 91174 Spalt
 Germany
 P: +49 9175 7909-200
 F: +49 9175 7909-29
 info.de@fath.net

FATH, Inc.
 6533 Hazeltine
 National Drive, Suite 3
 Orlando, FL 32822
 USA
 P: +1 407 - 601-5900
 F: +1 407 - 601-5905
 info.us@fath.net

FATH Machine Components
 (Shanghai) Co., Ltd.
 Building 2,
 No.2001 Shen Gang Road,
 Song Jiang, Shanghai, 201612
 China
 P: +86 21 5780 6395
 F: +86 21 5774 4520
 info.cn@fath.net

FATH Components BV
 Rudolf Dieselweg 14
 NL 5928 RA Venlo
 Netherlands
 P: +31 77 333 35 55
 F: +31 77 333 35 50
 info.nl@fath.net

FATH Components Ltd.
 6 Pegasus Court,
 North Lane
 Aldershot,
 Hampshire, GU12 4QP
 Great Britain
 P: +44 1252 346610
 F: +44 1252 330840
 info.gb@fath.net

FATH Components Kft.
 H-2040 Budaörs,
 Gyár u. 2.
 Hungary
 P: +36 23 880-977
 F: +36 23 880-978
 info.hu@fath.net

Überreicht von:
 Presented by:

