

|                |          |   |                |                                |           |                  |                  |              |                               |
|----------------|----------|---|----------------|--------------------------------|-----------|------------------|------------------|--------------|-------------------------------|
| <b>southco</b> |          | PROPRIETARY ITEM - EXCEPT FOR USES EXPRESSLY<br>STATED IN WRITING INFORMATION DISCLOSED<br>HEREIN IS CONFIDENTIAL AND ALL RIGHTS PAINTED<br>AND OTHERWISE ARE RESERVED BY SOUTHCO, INC. |                | TITLE<br>TOGGLE LATCH ASSEMBLY |           | DATE<br>20-02-06 | DRAWN/CHKD<br>AW | SCALE<br>2:1 | DRAWING NUMBER<br>J-TL-20-101 |
| REV            | DATE     | DRAWN/CHKD  | DESCRIPTION    | PART NUMBER                    | MATERIAL  | FINISH           |                  |              |                               |
| B              | 20-02-06 | W Waldron   | FRN P2006-0282 | TL-20-101-XX                   | SEE TABLE | SEE TABLE        |                  |              |                               |
|                |          |   |                |                                |           |                  |                  |              |                               |
|                |          |   |                |                                |           |                  |                  |              |                               |
|                |          |   |                |                                |           |                  |                  |              |                               |
|                |          |   |                |                                |           |                  |                  |              |                               |
|                |          |   |                |                                |           |                  |                  |              |                               |
|                |          |   |                |                                |           |                  |                  |              |                               |

**MILLIMETERS**  
 TOLERANCES (UNLESS OTHERWISE NOTED)  
 HOLE No's  
 ONE PLACE DEC.  
 TWO PLACE DEC.  
 HOLE DIA.  
 ANGLES

THIRD ANGLE PROJECTION

A3 PAPER SIZE

# INDICATES DIMENSION WITH SIGNIFICANT CHARACTERISTIC

FILE No. XX

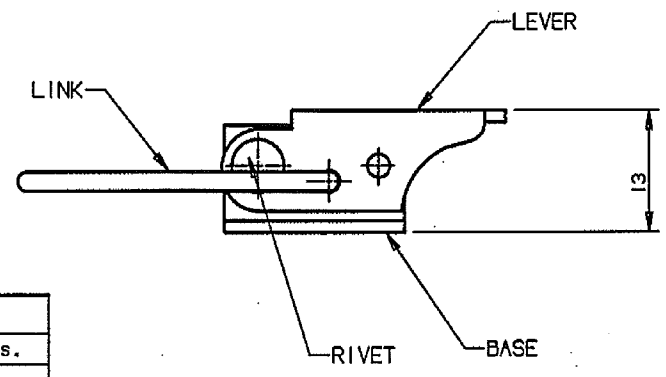
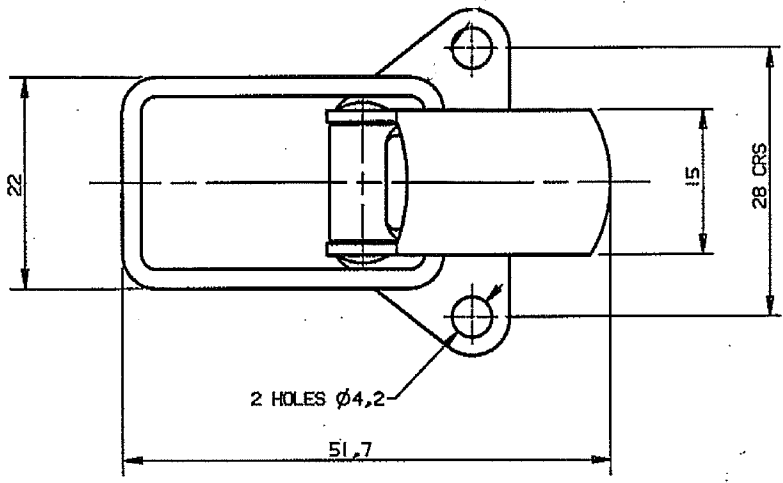

| PART No.     | LEVER No | BASE No | LINK No | RIVET No | MATL/FINISH No               |
|--------------|----------|---------|---------|----------|------------------------------|
| TL-20-101-07 |          |         |         |          | ZINC PLATE & TRIVALENT PASS. |
| TL-20-101-52 |          |         |         |          | STAINLESS STEEL / CLEAN      |
|              |          |         |         |          |                              |
|              |          |         |         |          |                              |
|              |          |         |         |          |                              |